

BELL SYSTEM PRACTICES
Transmission Engineering and Data
Vacuum Tube Data

SECTION AB46.035
April 1941 Issue 1
A T & T Co Standard

Western Electric

104D Vacuum Tube (Dome)

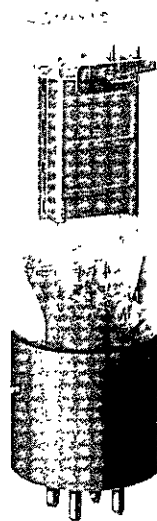

Classification—Filamentary, power amplifier triode

This tube replaces the D-86327 tube and has been assigned the old code number 104D. It includes an improved filament, a new mechanical design using transverse mica supports and is mounted in a dome type bulb. The electrical characteristics are essentially the same as for the D-86327 tube.

Applications—Voice frequency and carrier frequency amplifier for telephone repeater equipment requiring greater power outputs than can be obtained from the 101D or 101F type tubes.

Volume limiter in carrier telephone equipment.

Amplifier in various testing apparatus.

Dimensions and Connections—The outline diagrams of the tube and base, giving the dimensions and the arrangement of the electrode connections to the base terminals are shown in Figures 1 and 2.

Base and Mounting—This vacuum tube employs a medium, four-pin bayonet type base having special contact metal at the ends of the pins. It is suitable for use in a Western Electric 100L, 100R or similar type socket, preferably provided with contact-metal contacts.

The tube may be mounted in either a vertical or horizontal position. If mounted in a horizontal position the plane of the filament, which is indicated in Figure 2, should be vertical. To assure adequate ventilation the tubes should be mounted with not less than 2⁵/₈ inches between centers when two or more tubes are used.

Average Direct Interelectrode Capacitances

Grid to plate.	4.9 $\mu\mu\text{f.}$
Grid to filament.	4.1 $\mu\mu\text{f.}$
Plate to filament.	3.4 $\mu\mu\text{f.}$

These values are for a based tube without socket.

Filament Rating

Filament current.	1.00 ampere, d.c.
Nominal filament voltage.	4.5 volts

The filament of this tube is designed to operate on a current basis and should be operated as near to the rated current as practicable.

The filament resistance of this tube increases slightly during the first 2000 hours of operation. The voltage given above is the nominal value after the resistance has stabilized.

Characteristics—Typical curves showing plate current as a function of grid voltage for several values of plate voltage are shown in Figure 3. The grid and plate voltages are measured from the negative end of the filament. Corresponding amplification factor, plate resistance and transconductance characteristics are given in Figures 4, 5 and 6 respectively. Plate current as a function of plate voltage for several values of grid voltage is shown in Figure 7.

Operating Conditions and Output—Permissible operating plate and grid voltages are included within the area, ABCD in Figure 3. A number of recommended and maximum operating conditions and the corresponding values of amplification factor, plate resistance, transconductance, and performance data are given in the table.

Recommended conditions or others of no greater severity should be selected in preference to maximum conditions wherever possible. The life of the tube at maximum operating conditions will be shorter than at less severe conditions.

The performance data shown includes the fundamental power output in milliwatts and the second and third harmonic levels in db below the fundamental for values of load resistance equal to the plate resistance and for a load resistance of 5000 ohms. The peak value of sinusoidal input voltage E_{gm} , which gives the indicated output P_m , and harmonic levels F_{2m} and F_{3m} , in each case is numerically equal to the grid bias. For a smaller input voltage E_g , the approximate levels may be computed from the following relations:

$$P = P_m \left(\frac{E_g}{E_{gm}} \right)^2$$

$$F_2 = F_{2m} + 20 \log_{10} \frac{E_{gm}}{E_g}$$

$$F_3 = F_{3m} + 40 \log_{10} \frac{E_{gm}}{E_g}$$

Microphonic Noise

For a plate voltage of 130 volts, a grid bias of -20 volts, and a load resistance of 100,000 ohms, the mean microphonic output level of this tube, measured in a laboratory reference test set is 31 db below 1 volt. The range of levels of individual tubes extends from 20 to 40 db below 1 volt. Since microphonic noise output depends on the type and intensity of the mechanical disturbance which produces it, the values given here are useful chiefly for comparison with the levels of other types of tubes which have been tested in the same way.

TABLE

	<u>Plate Voltage</u>	<u>Grid Bias</u>	<u>Plate Current</u>	<u>Amplification Factor</u>	<u>Plate Resistance</u>	<u>Trans-conductance</u>	<u>Load Resistance</u>	<u>Power Output</u>	<u>Second Harmonic</u>	<u>Third Harmonic</u>
	Volts	Volts	Milli-amperes		Ohms	Micro-mhos	Ohms	Milli-watts	db	db
Recommended Operating Conditions	100	-20	12.5	2.4	2700	890	2700 5000	110 100	23 28	50 65
	100	-10	22.5	2.6	2200	1160	2200 5000	38 32	34 38	60 65
	130	-30	14.5	2.3	2600	900	2600 5000	250 225	22 25	47 75
	130	-20	25.0	2.5	2100	1180	2100 5000	150 125	28 32	48 58
	130	-10	37.0	2.6	1800	1430	1800 5000	45 36	38 44	65 70
	160	-45	13.0	2.3	2900	810	2900 5000	475 445	18 21	37 49
	160	-35	21.5	2.4	2300	1040	2300 5000	390 340	22 27	47 70
Maximum Operating Conditions	160	-25	33.0	2.5	1900	1300	1900 5000	250 210	28 33	49 53
	190	-55	15.5	2.3	2800	810	2800 5000	735 700	18 22	36 48
	190	-45	24.5	2.4	2200	1070	2200 5000	650 565	22 26	45 65

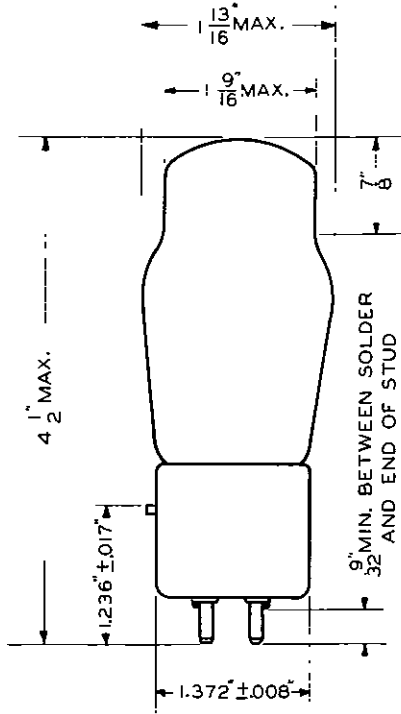
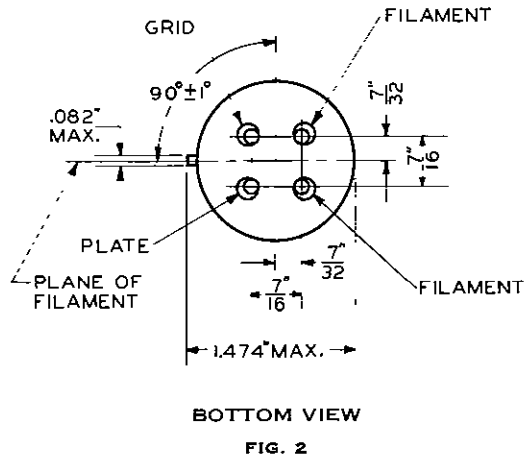

FIG. 1



BOTTOM VIEW
FIG. 2

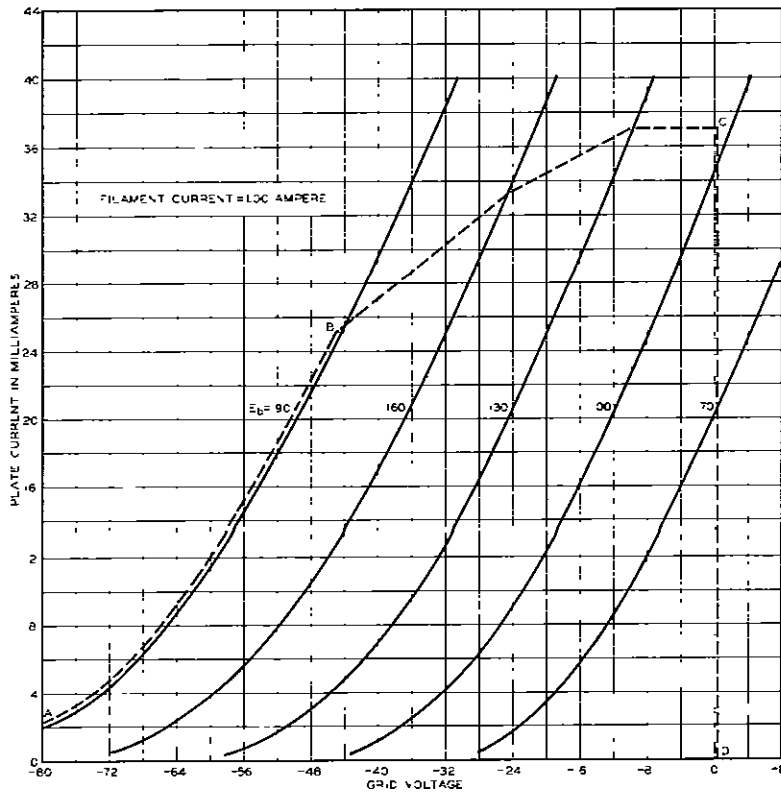

FIG. 3

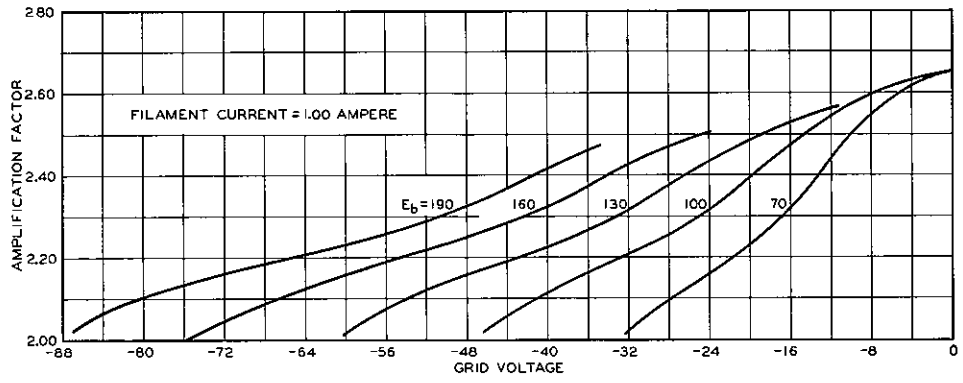

FIG. 4

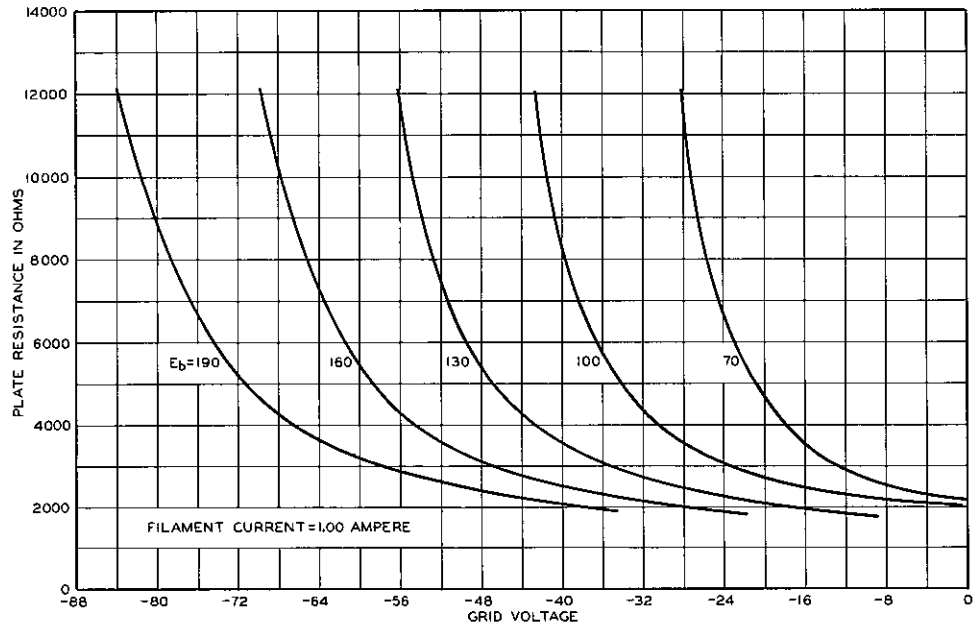

FIG. 5

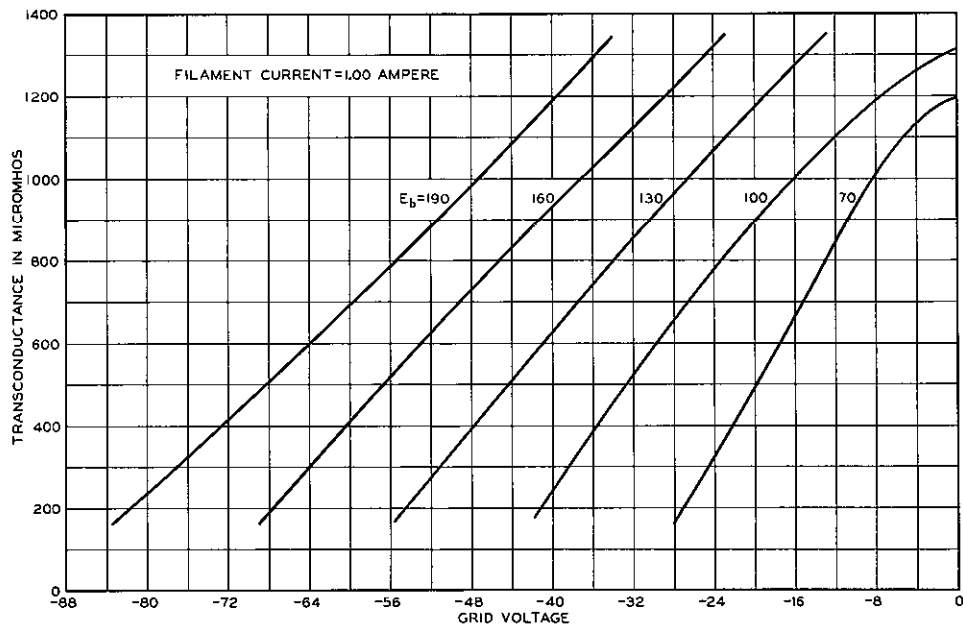

FIG. 6

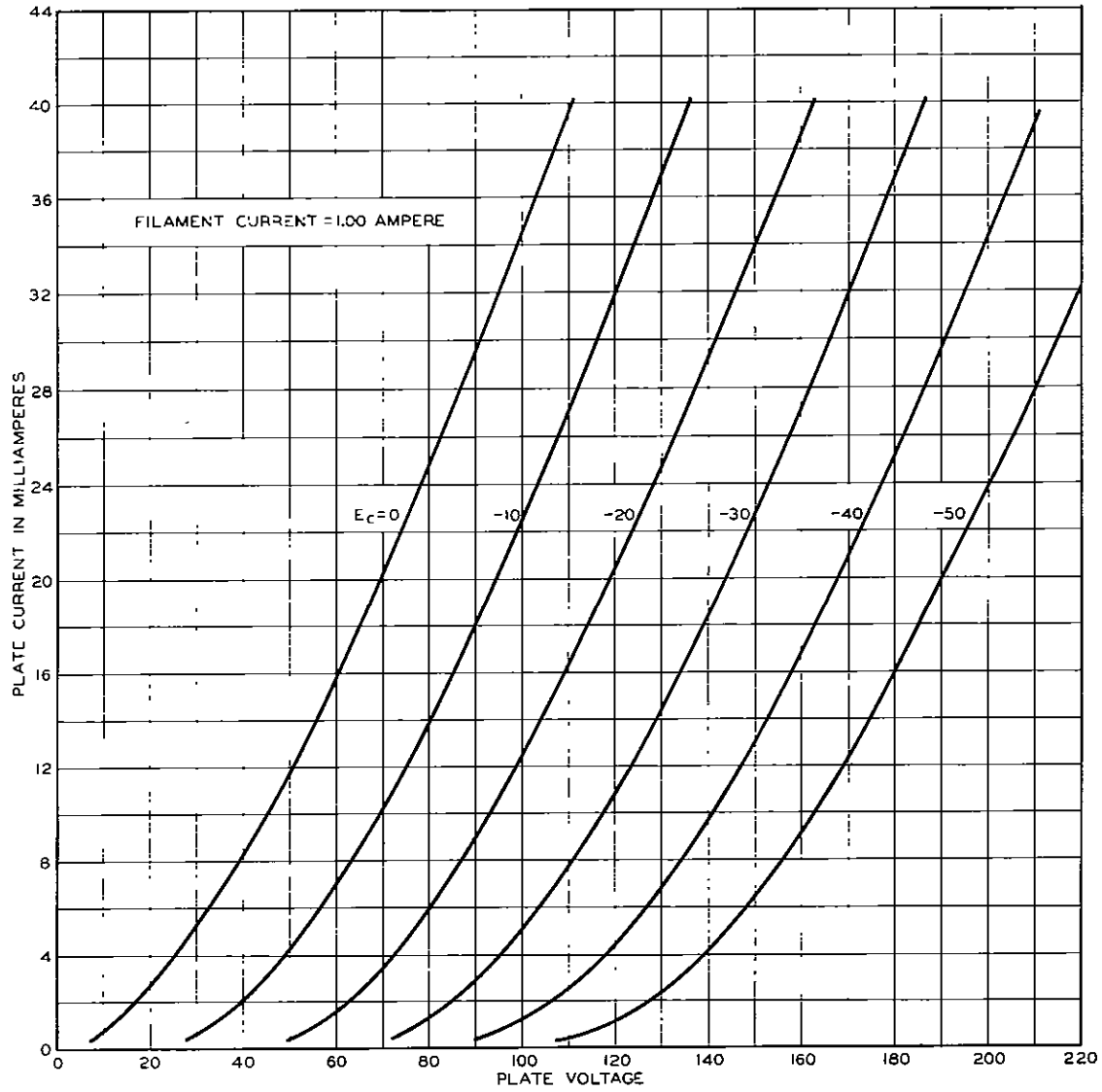

FIG. 7