

Description :

300B SE, Single Ended Tube Amplifier

Tubes used : Emission Labs 300B-XLS, 12BH7, 6H30

Neutral 300B sound with exceptionally fine detail and resolution.

Large size, Single Ended Output Transformer, for transparent sound reproduction and excellent dynamic behavior.

With very low feedback design for increase damping factor.

Exactly customizable in 3 stages for 4 ohm to 8 ohm speaker.

Suitable for loudspeaker boxes of 86 db or higher.

Version: BLADE 1.0 --- 03.05.2019

The operating point of the power tubes is simple and precise, a mix of autobias and negative grid bias allows a precise, stable operating point of the end tubes.
request to complete wiring diagram info.levamp@t-online.de



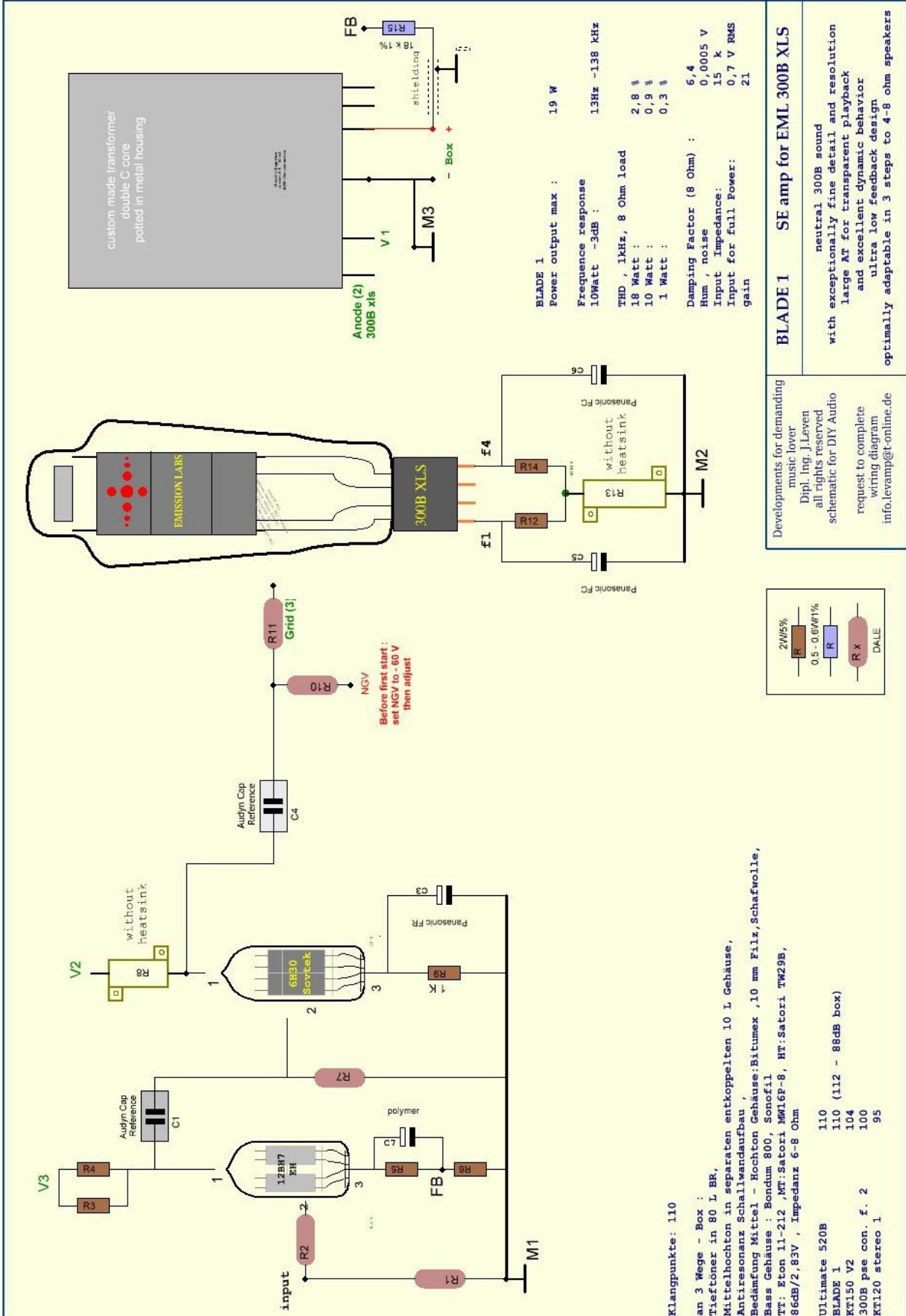

custom made transformer
double C core
potted in metal housing

BLADE 1
 Power output max : 19 W
 Frequency response 10Watt -3dB : 13Hz -138 kHz
 THD , 1kHz, 8 Ohm load : 2,8 %
 18 Watt : 0,9 %
 10 Watt : 0,3 %
 1 Watt :
 Damping Factor (8 Ohm) : 6,4
 Hum , noise : 0,0005 V
 Input Impedance: 15 k
 Input for full Power: 0,7 V RMS
 gain : 21

BLADE 1 SE amp for EML 300B XLS
 neutral 300B sound
 with exceptionally fine detail and resolution
 large AT for transparent playback
 and excellent dynamic behavior
 ultra low feedback design
 optimally adaptable in 3 steps to 4-8 ohm speakers

Developments for demanding
 music lover
 Dipl.-Ing. J. Leven
 all rights reserved
 schematic for DIY Audio
 request to complete
 wiring diagram
 info.levenp@t-online.de

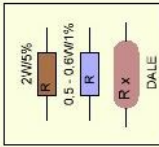

Klangpunkte: 110

an 3 Wege - Box :
 Tieftöner in 80 L BR,
 Mittelhochton in separaten entkoppelten 10 L Gehäuse,
 Antiresonanz Schallwandaufbau ,
 Bedämpfung Mittel - Hochton Gehäuse:Bitumex ,10 mm Filz,Schafwolle,
 Bass Gehäuse : Bondum 800, Sonofil
 TT: Eton 11-212 ,MT:Satori MM16P-8, HT:Satori TW29B,
 86dB/2,83V , Impedanz 6-8 Ohm

- Ultimate 520B 110
- BLADE 1 110 (112 - 88dB box)
- KT150 V2 104
- 300B pse con. f. 2 100
- KT120 stereo 1 95

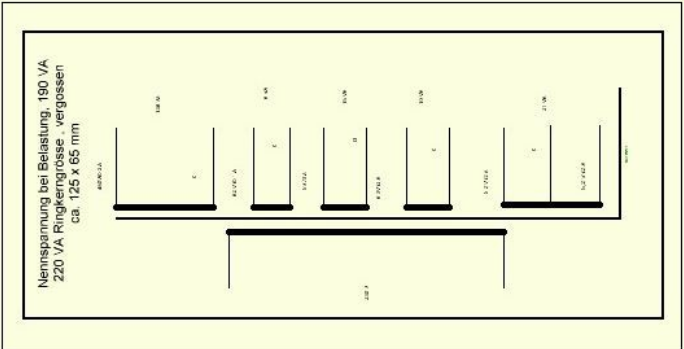
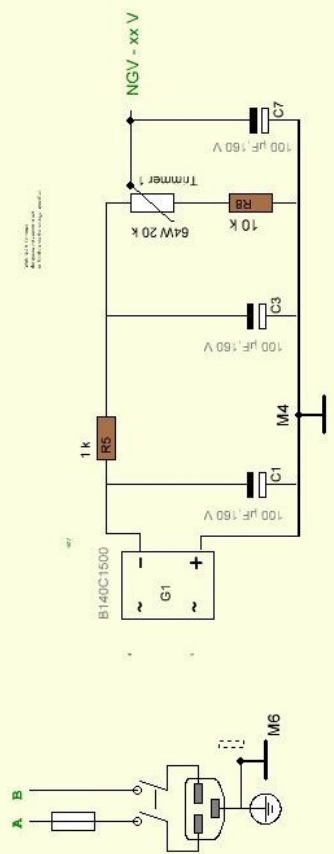
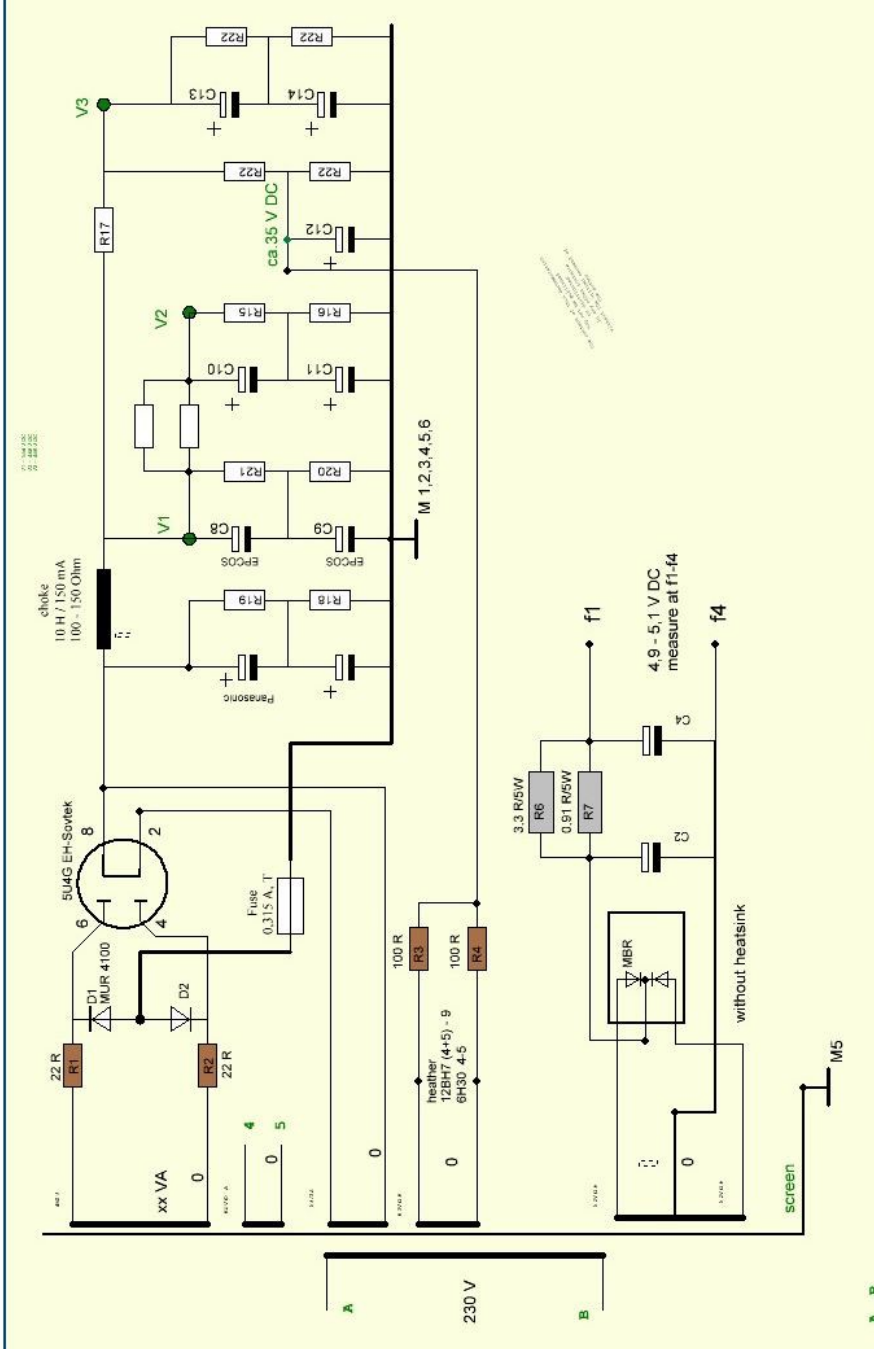

BLADE 1 mono power supply

Developments for demanding music lover
 Dipl.-Ing. J. Leven
 all rights reserved
 schematic for DIY Audio
 request to complete wiring diagram
 info.levamp@t-online.de

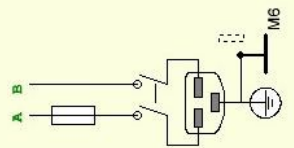

Overview of the amplifiers, for a better comparison, there are now sound points, the rating is price independent, it counts the personal sound impression (of me), which was found over several months and with different music material.

Box 1:

to 3 ways - box:

Woofers in 80 L BR,

Mid-high in separate decoupled 10 L case,

Anti-resonance baffle construction,

Bedding Medium - Hochtong Case: Bitumex, 10 mm felt, sheep wool,

Bass Case: Bondum 800, Sonofil

TT: Eton 11-212, MT: Satori MW16P-8, HT: Satori TW29B,

86dB / 2,83V, impedance 6-8 ohms

amp	Points box 1	box 2	description
Ultimate 520B	110		520B V3 SE
BLADE 1	110		300B xls SE
KT150 V2	104		KT150 SE ultra class A
300B pse con f.	100		300B PSE
KT120 stereo 1	95		KT120 SE
KT120 Agile	95		KT120 SE
David KT88 PP			KT88 PP
300B xls pse			In development
520B pse			In development
KT150 PP			In development