

# Trainwreck Express Version A0

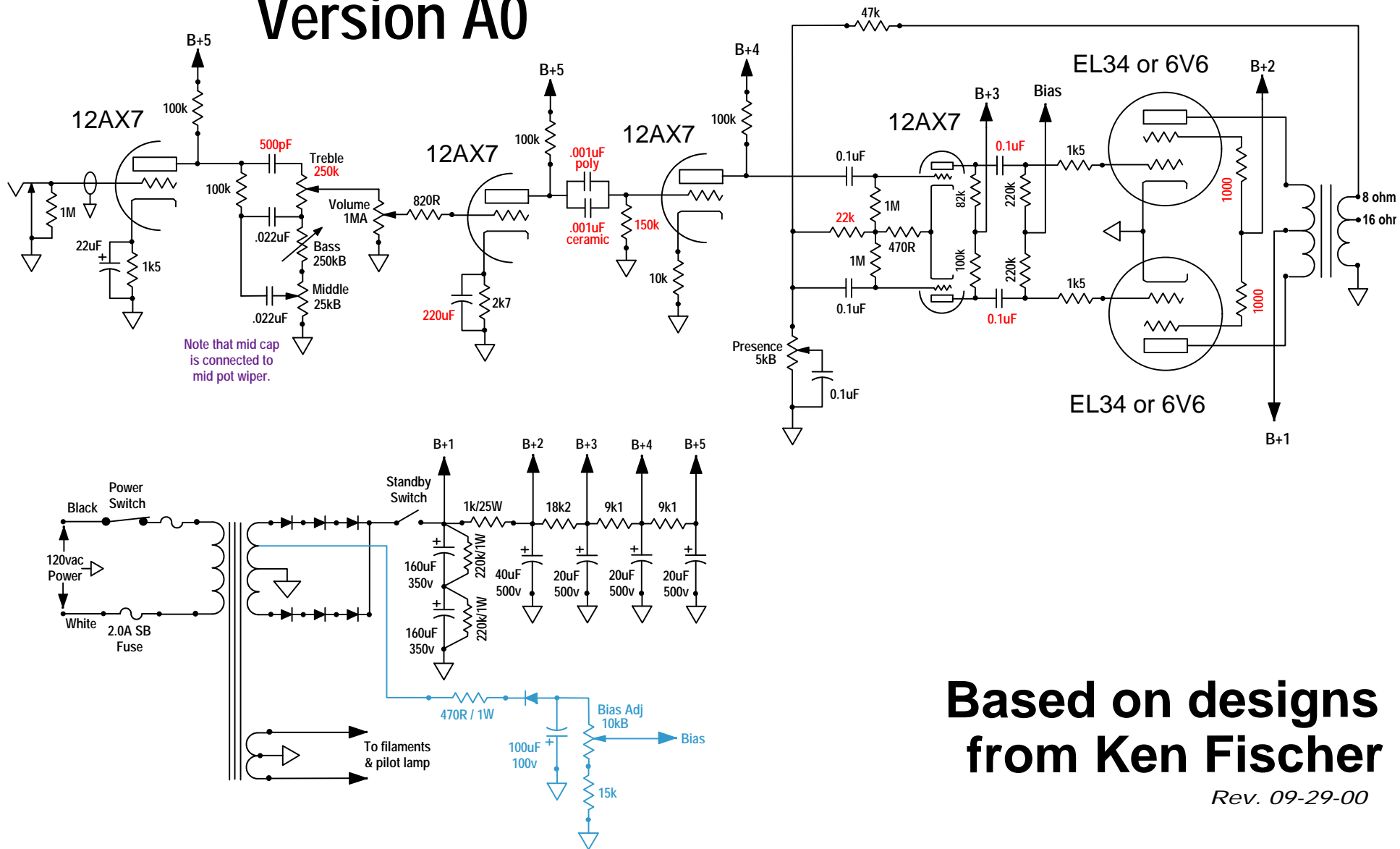

Based on designs  
from Ken Fischer

Rev. 09-29-00

# Trainwreck Express Version A1

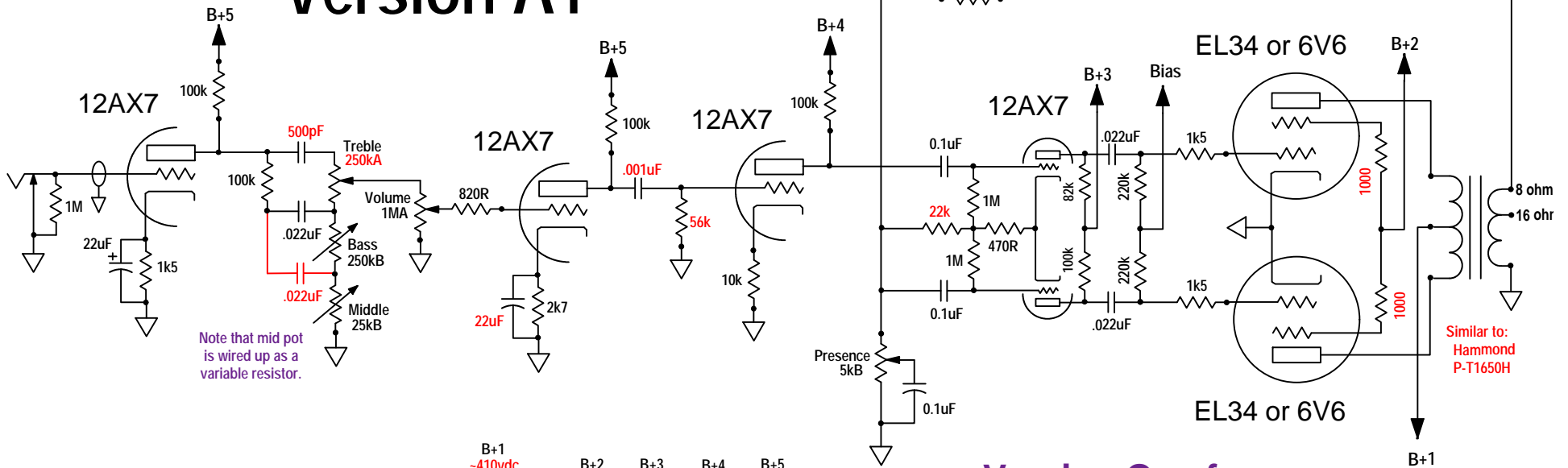

Note that mid pot is wired up as a variable resistor.

Version One from...  
"The Mystery Man"

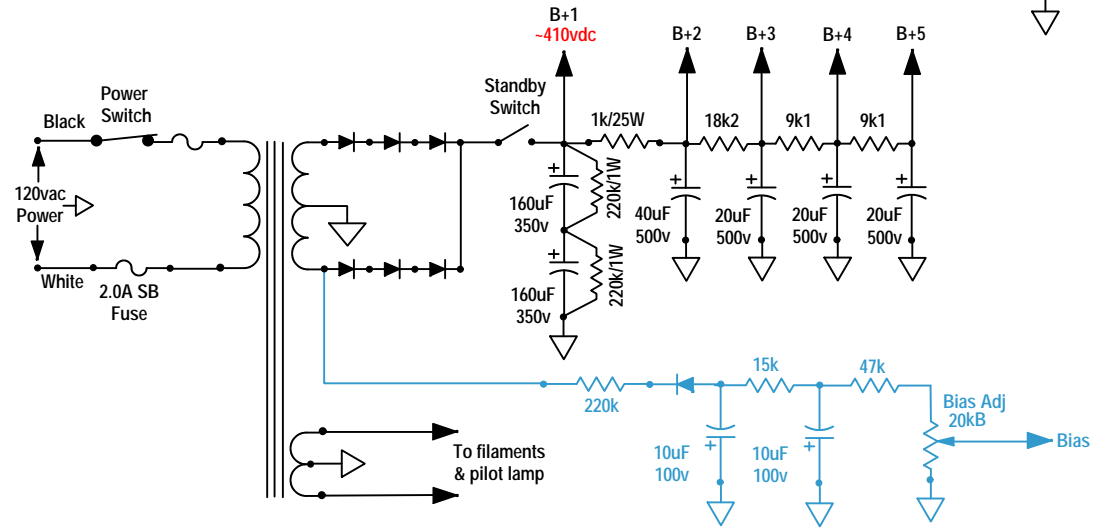

Based on designs  
from Ken Fischer

Rev.09-29-00

# Trainwreck Express Version A1a

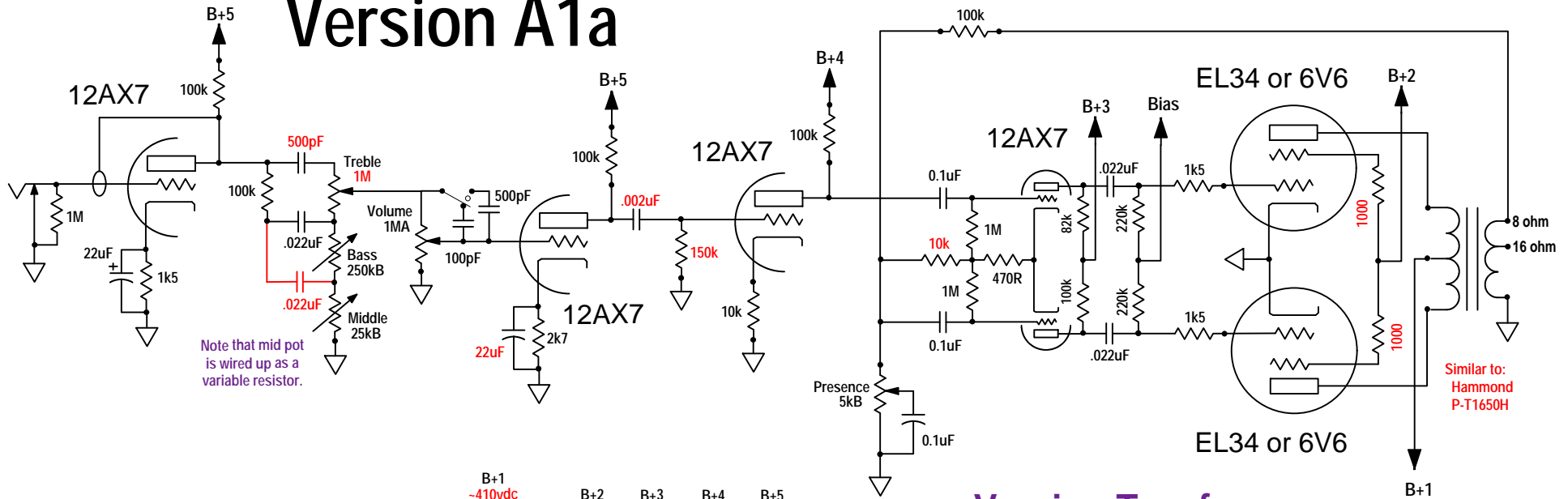

Version Two from...  
"The Mystery Man"

Based on designs  
from Ken Fischer

Rev.09-29-00

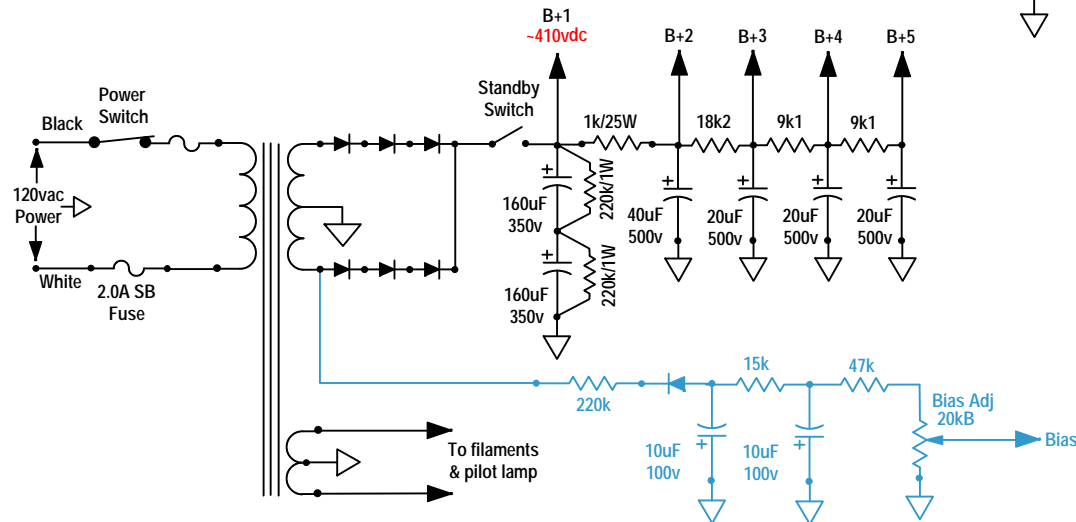

# Trainwreck Express Version A1b

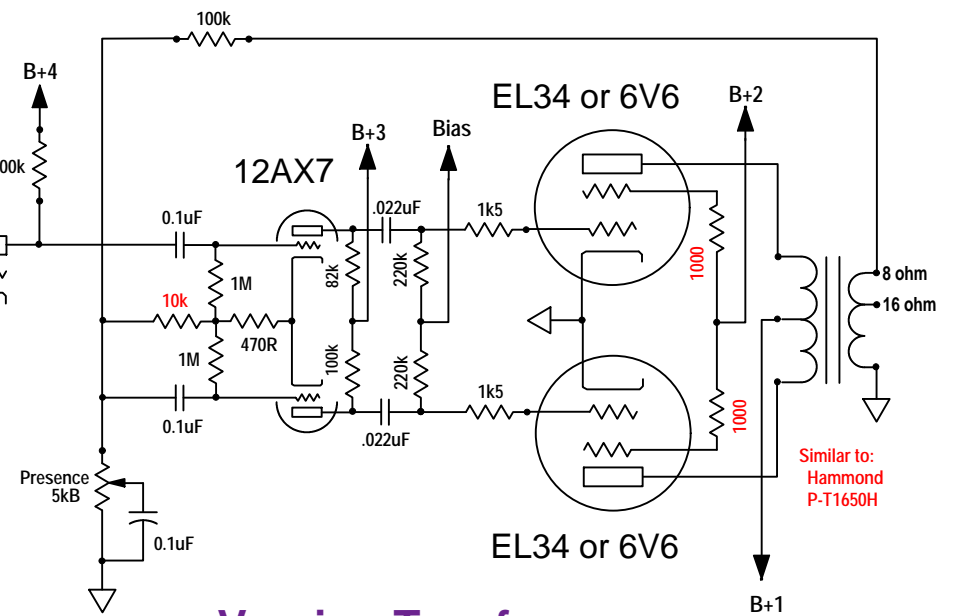
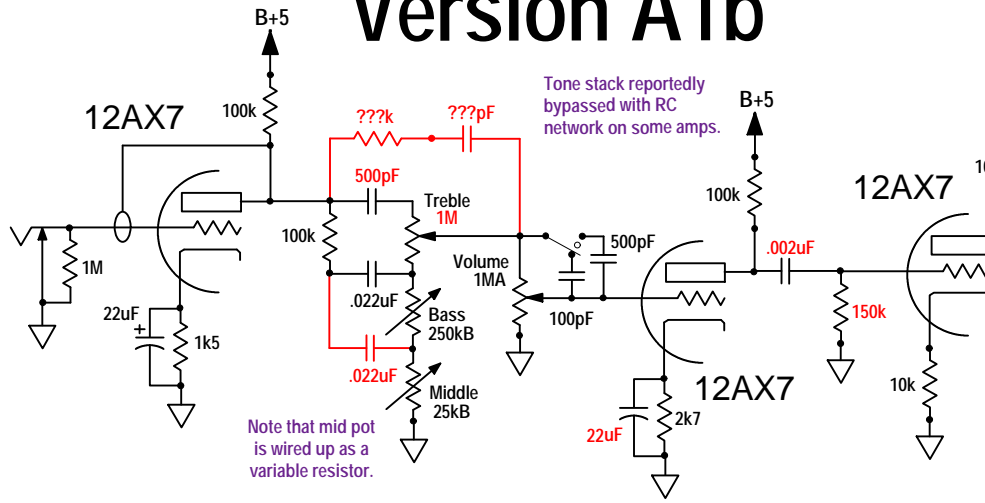

Version Two from...  
"The Mystery Man"

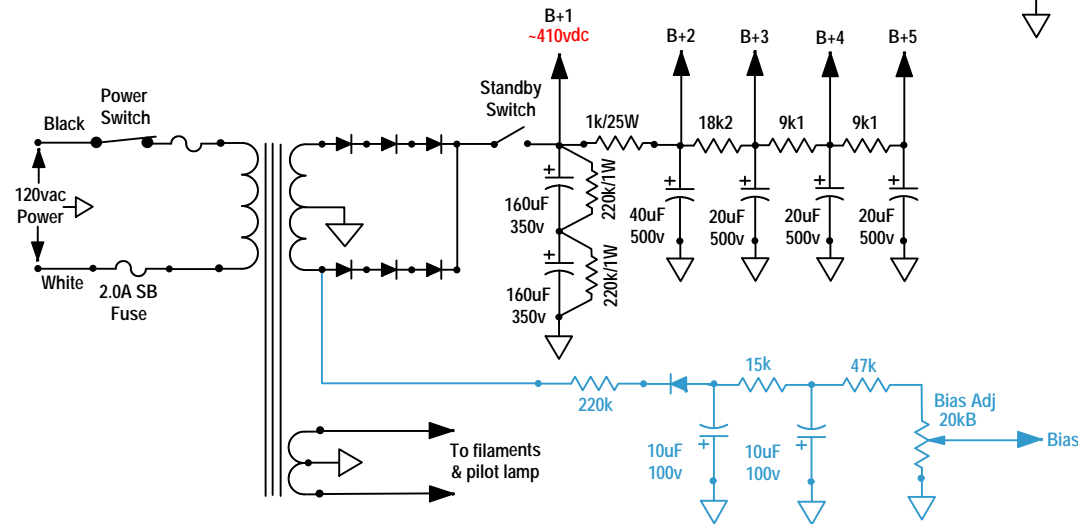

Based on designs  
from Ken Fischer

Rev.09-29-00

# Trainwreck Express Version A2

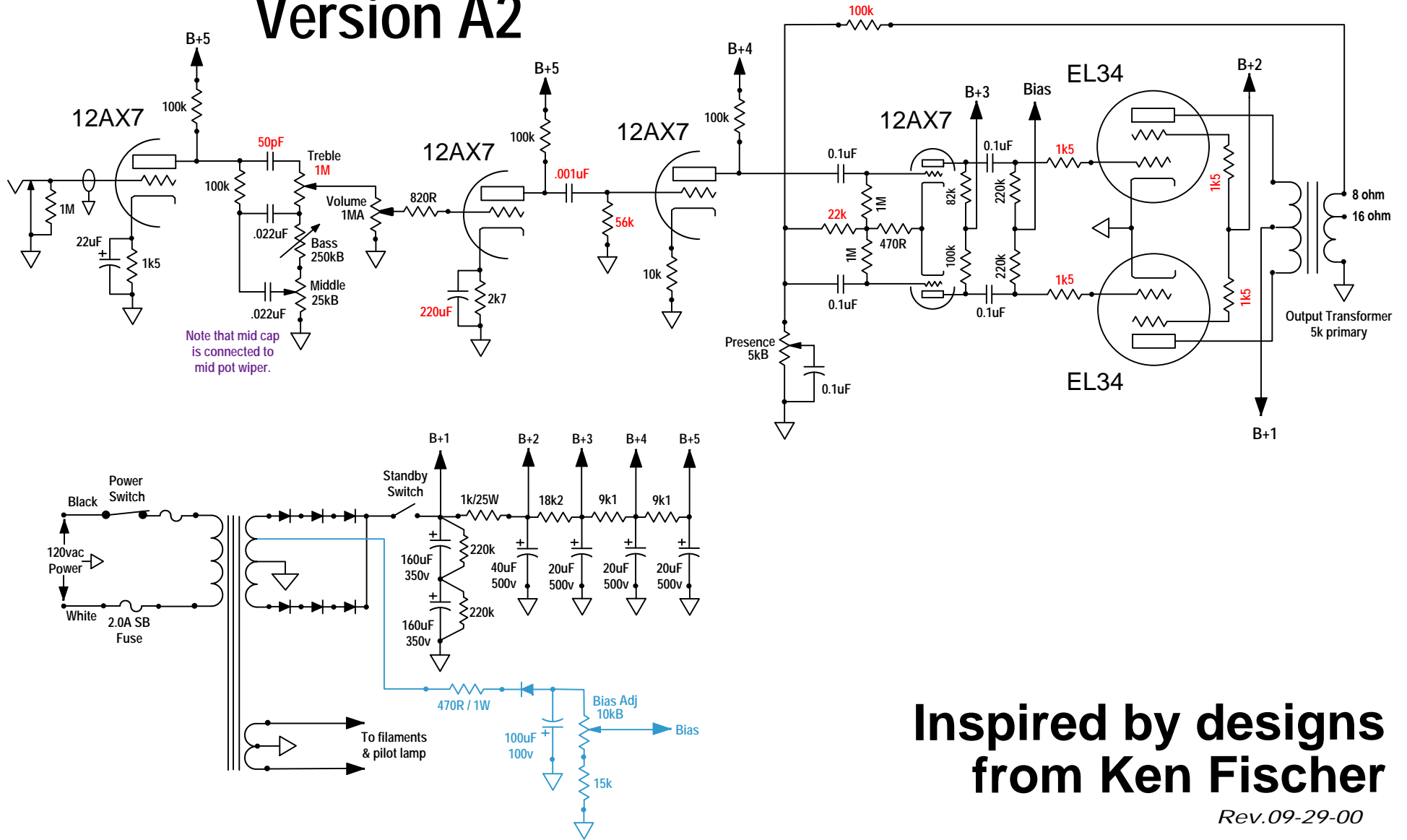

Inspired by designs  
from Ken Fischer

Rev.09-29-00

# Trainwreck Express Version A3

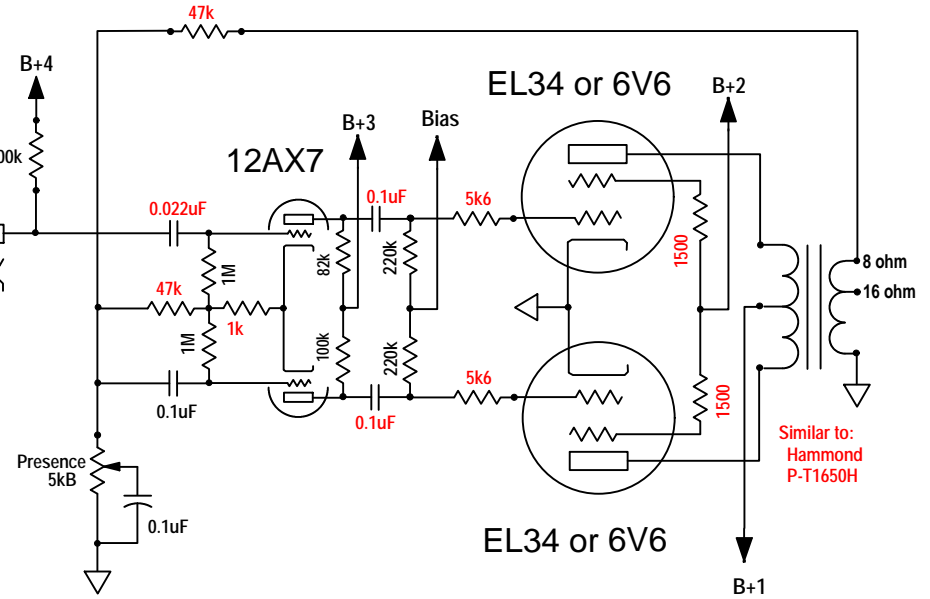
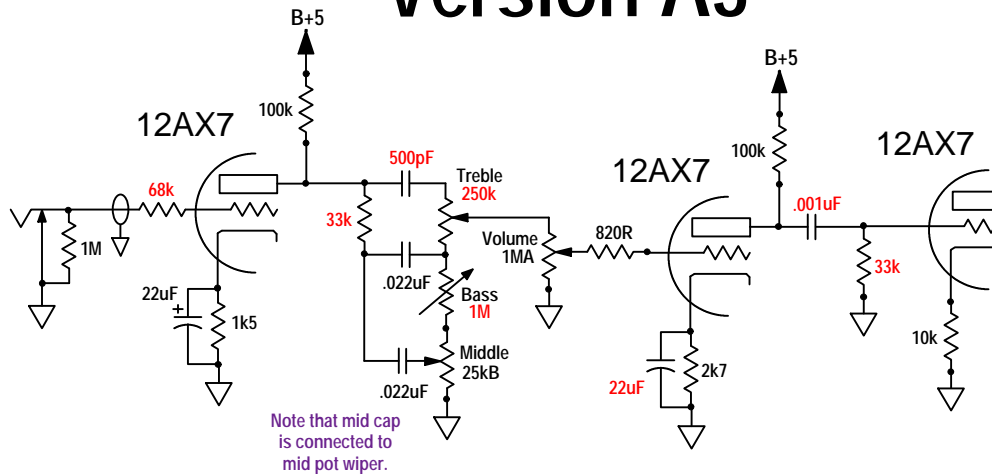

"How's it sound? Like the first Van Halen album..."

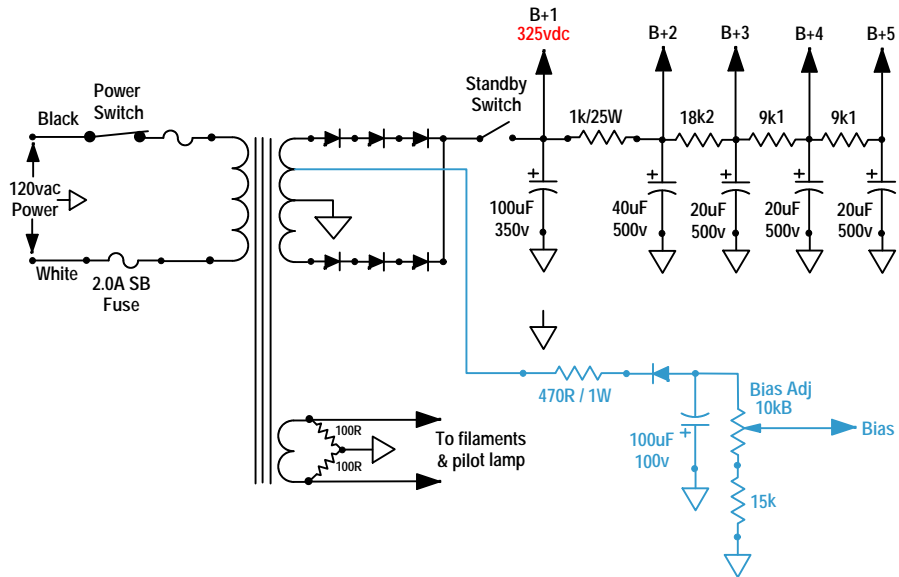

## A DIY clone inspired by designs from Ken Fischer

Rev.09-29-00

# Trainwreck Express Version A4

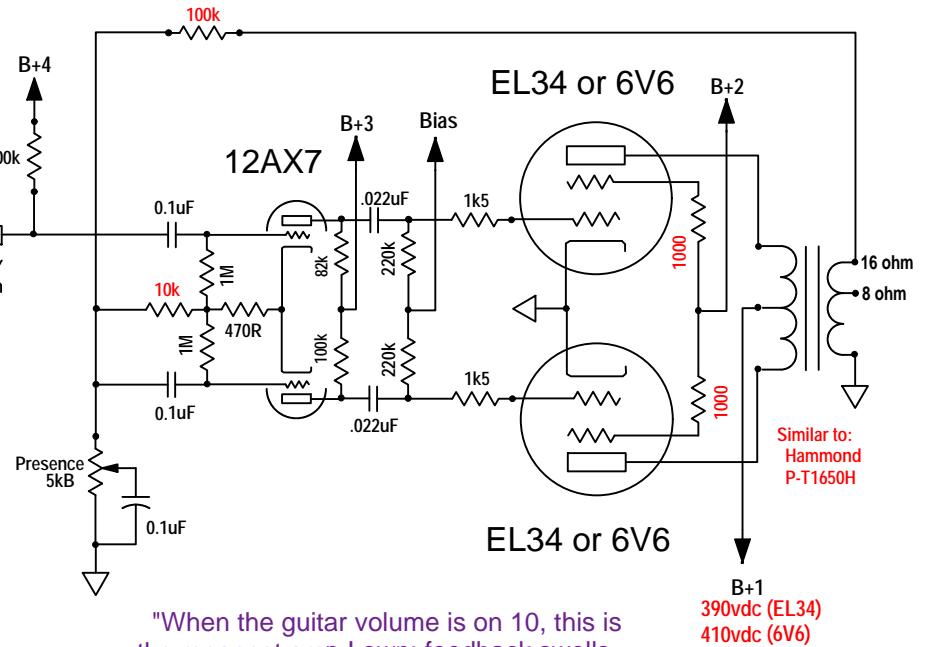
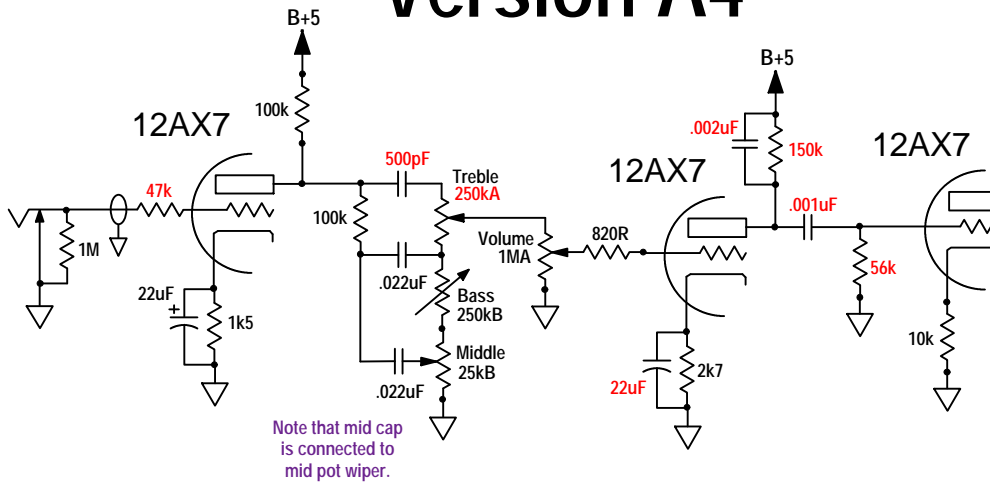

"When the guitar volume is on 10, this is the meanest amp I own; feedback swells into higher harmonics above the note, the low end doesn't mush out, thick mids yet clear top end.

When the guitar volume is rolled off, it becomes one of the sweetest and jangliest amps I've got."

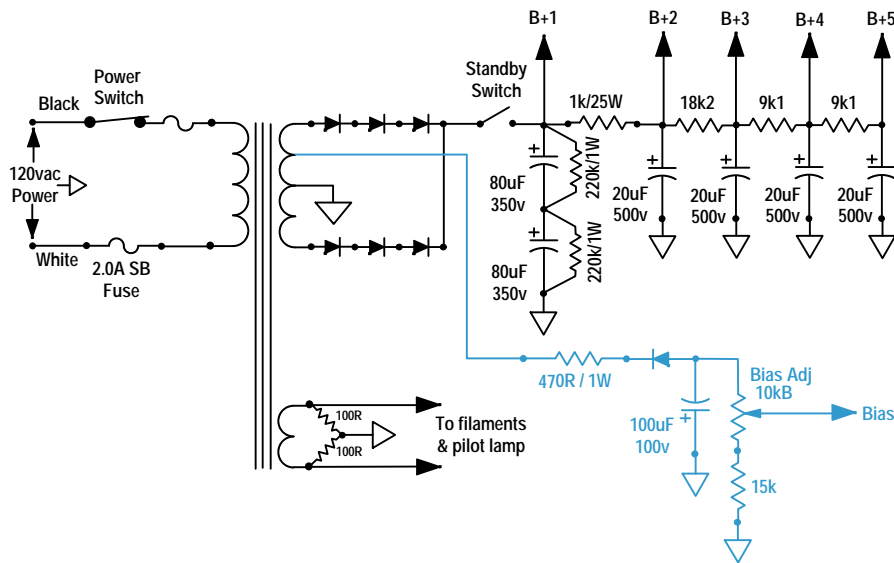

## A DIY clone inspired by designs from Ken Fischer

Rev.09-29-00

# The Blues Express Version A5h

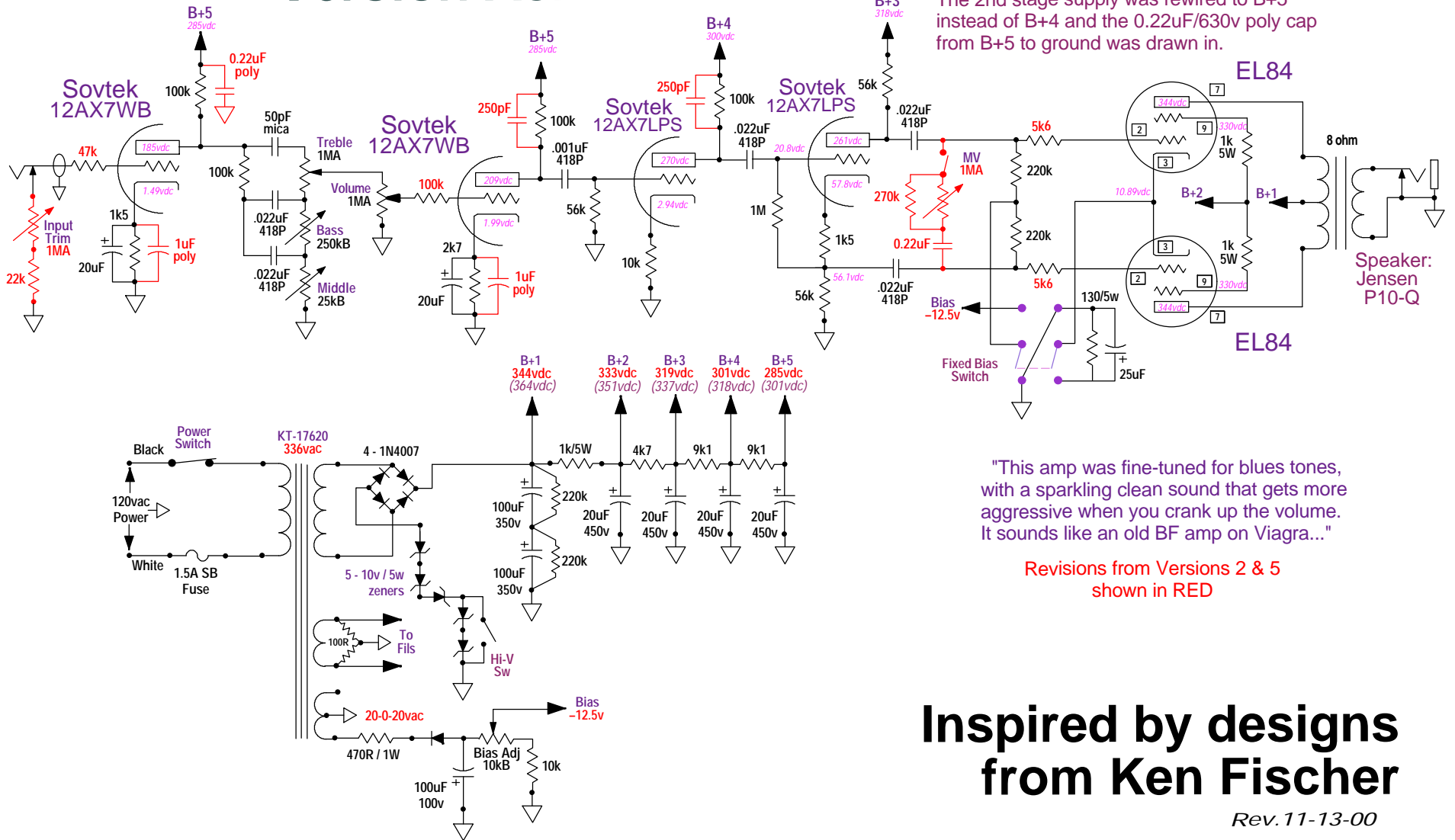

This is the final version of the Blues Express amp. The zener limiting circuit was removed and a modified cross-line MV was installed in its place. The bias/grid load resistors were returned to their original value of 220k. The 2nd stage supply was rewired to B+5 instead of B+4 and the 0.22uF/630v poly cap from B+5 to ground was drawn in.

"This amp was fine-tuned for blues tones, with a sparkling clean sound that gets more aggressive when you crank up the volume. It sounds like an old BF amp on Viagra..."

Revisions from Versions 2 & 5 shown in RED

## Inspired by designs from Ken Fischer

Rev. 11-13-00



# Trainwreck Express Version A6

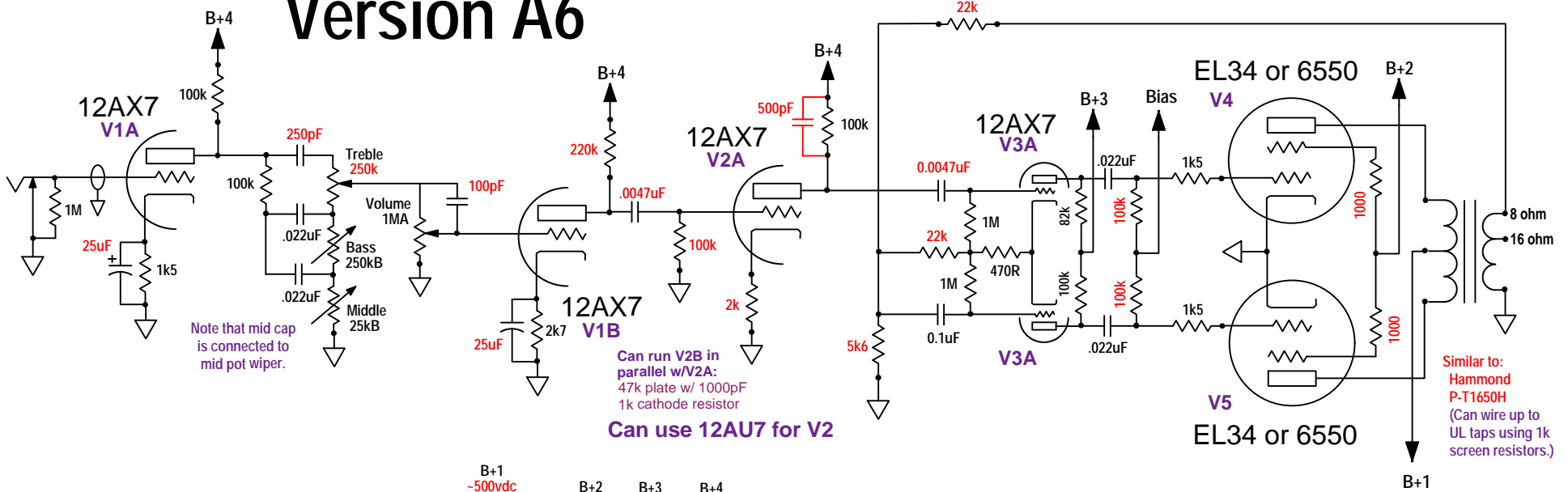

One cloner's take on  
the Express design.

Based on designs  
from Ken Fischer

Rev.09-29-00

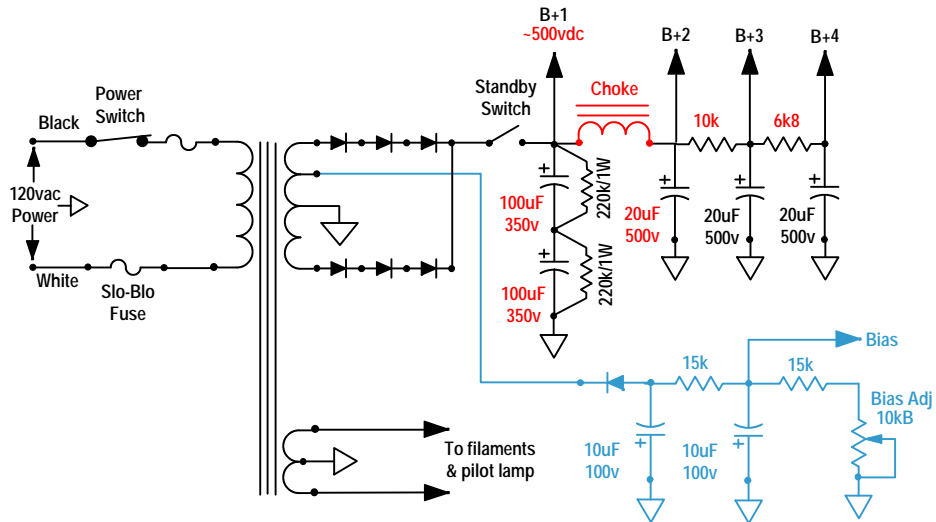

# Trainwreck Express Version A7

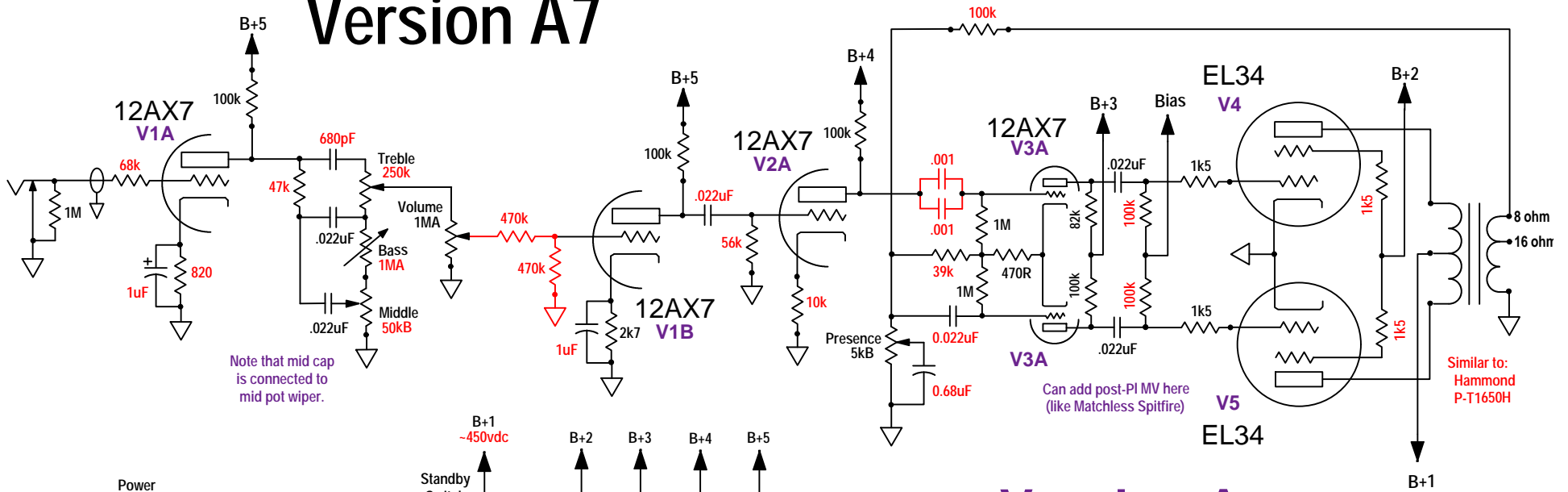

## Voodoo Amps "Blue-Tone" Amp

Based on designs  
from Ken Fischer

Rev.09-30-00

