

SUMMER
EDITION

CITIZENS

N.S.E.

50¢

Radio Call Book Magazine and Scientific Digest



RADIO - TELEVISION - MECHANICS

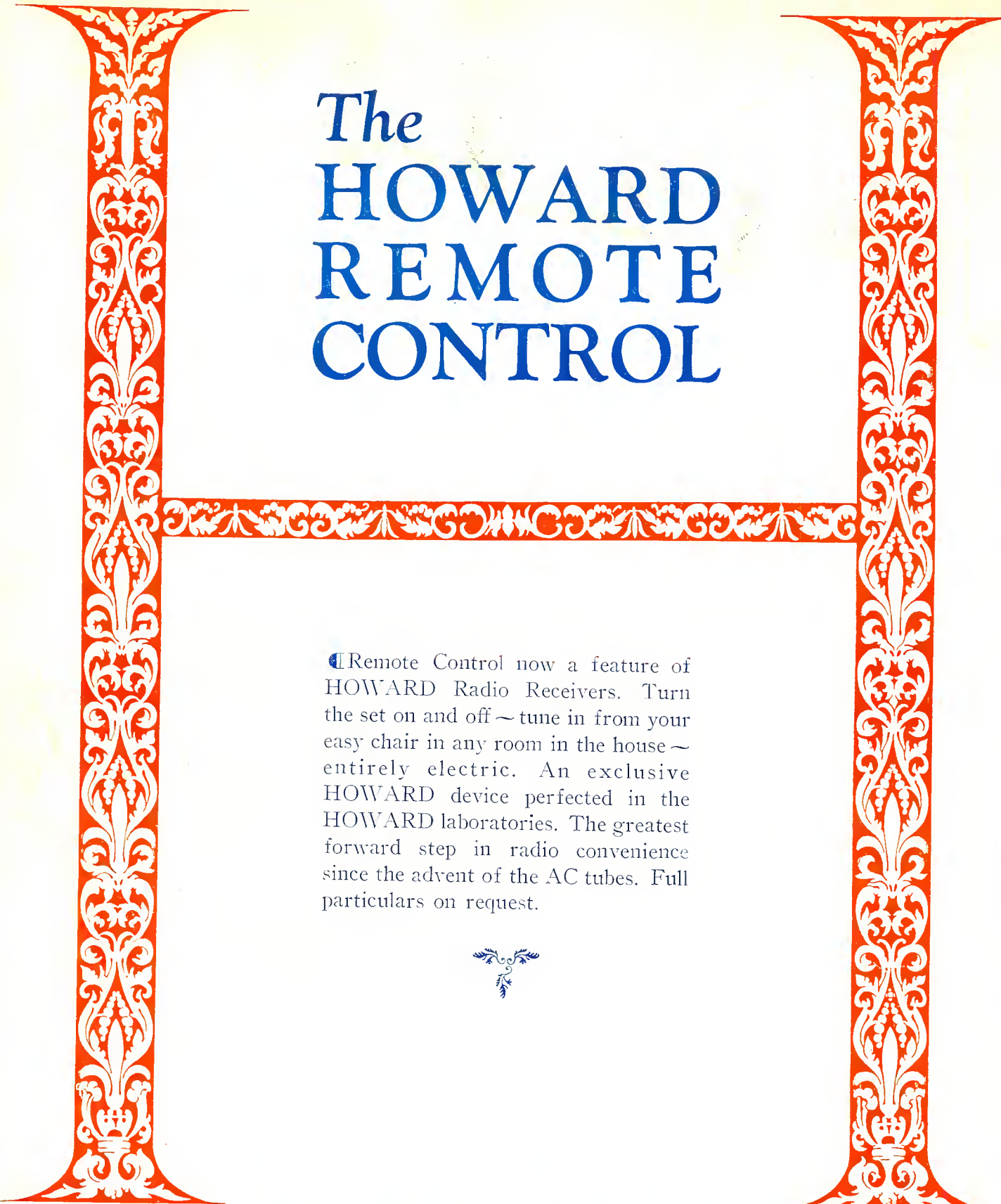

The
**HOWARD
REMOTE
CONTROL**

Remote Control now a feature of HOWARD Radio Receivers. Turn the set on and off ~ tune in from your easy chair in any room in the house ~ entirely electric. An exclusive HOWARD device perfected in the HOWARD laboratories. The greatest forward step in radio convenience since the advent of the AC tubes. Full particulars on request.



HOWARD RADIO

HOWARD RADIO COMPANY • CHICAGO • ILLINOIS

Factory and Executive Offices: South Haven, Michigan



W.C. BRAUN COMPANY

WHOLESALE RADIO HEADQUARTERS

What's Next?

THOUSANDS of radio dealers, set builders, technicians and service men, who have been working at a steady pace throughout the fall and winter of the busiest radio season ever known, are beginning to wonder what to do this Spring and Summer. Working at top-speed through the busy radio season, our own organization some time ago, was confronted with the same situation.

Several years ago, however, the W. C. Braun Co., hit the bull's-eye when they started an experiment that effectively solved this problem happily by adding some new lines of goods to our stock—and the idea took so well with our customers, that today not only our own big force, but thousands of our customers and their employees are enjoying a steady, dependable, profitable business from January first through to the end of December, a business that keeps going every month of the year.

This idea has proved so successful that thousands of our customers are doing a big business now during spring and summer in portable radios and phonographs, auto tires and accessories, electrical appliances, camping and outing equipment, golf, tennis and baseball goods, bathing suits, household specialties and hundreds of items that are in daily demand and that sell the year 'round.

Don't think that your season is over just because *it used to be that way*. It isn't so any longer. Let Braun service point the way for your success, for constantly increasing sales for you, and for steady, day-by-day profits. Certainly you can do as well as so many others have done.

GIVE THIS NEW IDEA A TRIAL

Put our service to the test. Your trial order can be as small as you please. Our central location and our exceptional 12-hour service will keep you supplied as you need the goods, without stocking up for a season's supply in advance. You'll be surprised to see how little money it takes and how easy it is to do a thriving business.

GET BRAUN'S BUYERS' GUIDE NOW!

If you haven't received the big Spring edition of Braun's Catalog and Buyers' Guide, send for it now. Look it over and you'll soon see why we say—"Braun service makes you money the year 'round." Use the handy coupon now—and your profits will begin so much sooner.

W. C. BRAUN Co.
Pioneers in Radio
 559 West Randolph Street
CHICAGO
 ILLINOIS



Here Is The Coupon For Bigger Profits

W. C. BRAUN CO.,
 559 Randolph St., Chicago.

By all means send me free that Big Wholesale Buyers' Guide of yours in which you show the new 1929 ideas mentioned in your ad.

Name.....

Street and Number.....

City.....State.....

Tell 'Em You Saw It in the Citizens Radio Call Book Magazine and Scientific Digest

An investment that pays dividends

An indicating instrument is an essential part of the equipment of every good radio receiver installation, since it aids in maintaining efficient operation, secures the best reception and fully protects the financial investment.

To dealers and service men the selection of instruments is highly important. Testing equipment which insures reliability not only increases the efficiency of servicing work, but it is a factor in securing business—for the ability to quickly and accurately diagnose set troubles, as well as to test and certify tubes and other merchandise in a customer's presence, instils confidence and makes every purchaser a booster.

Illustrated and described herewith are four instruments selected from the complete Weston Radio Line because of their great utility as service instruments. Moreover, the small portable instruments are popular items of merchandise for over-the-counter sales. All four instruments represent a profitable investment on either side of the counter benefiting both the dealer and the customer on every transaction.



**A.C. and D.C. 3-Range
Voltmeters**

The excellent characteristics and performance of these portable models command the attention of all who appreciate the finest workmanship and demand unflinching reliability. They are enclosed in bakelite cases—black for D. C. and mottled red and black for A. C. instruments. D. C. Voltmeter—750/250/10 volts—1000 ohms per volt. A. C. Voltmeter—150/8/4 volts.

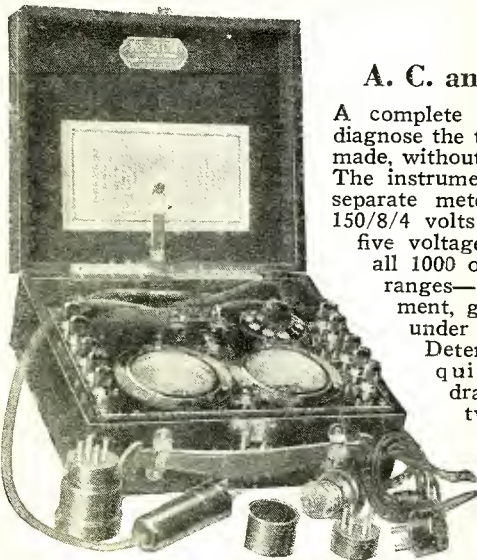

**Model 537
A. C. and D. C. Radio Set Tester**

A complete servicing outfit that will quickly diagnose the trouble in any type of radio receiver made, without need for any additional equipment. The instruments provided are equivalent to ten separate meters:—a 3-range A. C. Voltmeter, 150/8/4 volts; a D. C. Volt-Milliammeter with five voltage ranges—600/300/120/60/8 volts all 1000 ohms per volt); and two current ranges—150/30 milliamperes. Tests filament, grid, plate and cathode voltages under actual operating conditions.

Determines filament current requirements and plate current drain. Locates "shorts" between grid and plate as well as distortion in the audio system due to tube overloading. Provides for filament circuit and general continuity tests and also serves as a rapid tube tester.

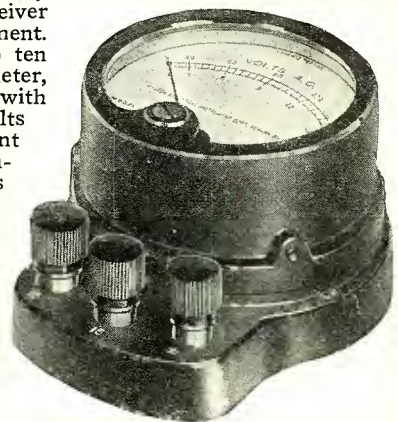

**A. C. and D. C. Single
and Double-Range
Instruments**

These instruments are identical to the model shown in the top illustration in design and electrical characteristics, except that they are made as single and double-range instruments with binding posts instead of pin-jacks. They are furnished as D. C. double-range voltmeters (125 or 1000 ohms per volt) and as single and double-range D. C. Ammeters. For A. C. testing they are made as single-range Ammeters and Milliammeters and double-range Voltmeters.

**Model 533
Counter
Tube Checker**

Requires no batteries. Operates direct from an A. C. light socket—or any other A. C.—60 cycle—90 to 130 volt—source of supply. Will test every type of tube—A. C. or D. C.—having filament voltages of 1.5, 2.5, 3.3, 5 or 7.5 volts, including rectifying type tubes. Proper voltage regulation is obtained quickly with the voltage adjusting dial and voltage indicator.

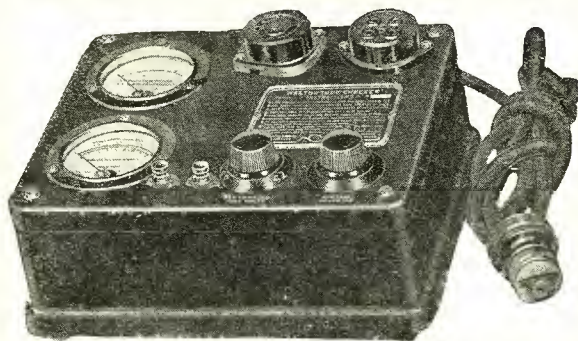

WESTON ELECTRICAL INSTRUMENT CORPORATION
574 Frelinghuysen Ave., Newark, N. J.

WESTON RADIO INSTRUMENTS

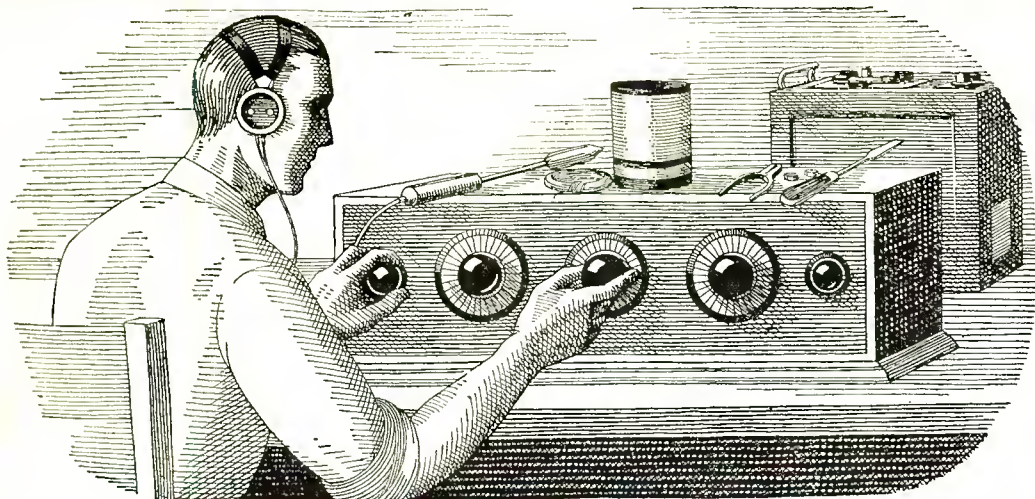

If all the Radio sets I've "fooled" with in my time were piled on top of each other, they'd reach about half-way to Mars. The trouble with me was that I thought I knew so much about Radio that I really didn't know the first thing. I thought Radio was a plaything—that was all I could see in it for me.

I Thought Radio Was a Plaything

But Now My Eyes Are Opened, And I'm Making Over \$100 a Week!

FIFTY DOLLARS A WEEK! Man alive, just one year ago a salary that big would have been the height of my ambition.

Twelve months ago I was scrimping along on starvation wages, just barely making both ends meet. It was the same old story—a little job, a salary just as small as the job—while I myself had been dragging along in the rut so long I couldn't see over the sides.

If you'd told me a year ago that in twelve months' time I would be making \$100 and more every week in the Radio business—whew! I know I'd have thought you were crazy. But that's the sort of money I'm pulling down right now—and in the future I expect even more. Why, only today—

But I'm getting ahead of my story. I was hard up a year ago because I was kidding myself, that's all—not because I had to be. I could have been holding then the same sort of job I'm holding now, if I'd only been wise to myself. If you've fooled around with Radio, but never thought of it as a serious business, maybe you're in just the same boat I was. If so, you'll want to read how my eyes were opened for me.

WHEN broadcasting first became the rage, several years ago, I first began my dabbling with the new art of Radio. I was "nuts" about the subject, like many thousands of other fellows all over the country. And no wonder! There's a fascination—something that grabs hold of a fellow—about twirling a little knob and suddenly listening to a voice speaking a thousand miles away! Twirling it a little more and listening to the mysterious dots and dashes of steamers far at sea. Even today I get a thrill from this strange force. In those days, many times I stayed up almost the whole night trying for DX. Many times I missed supper because I couldn't be dragged away from the latest circuit I was trying out.

I never seemed to get very far with it, though. I used to read the Radio magazines and occasionally a Radio book, but I never understood the subject very clearly, and lots of things I didn't see through at all.

So, up to a year ago, I was just a dabbler—I thought Radio was a plaything. I never realized what an enormous, fast-

growing industry Radio had come to be—employing thousands and thousands of trained men. I usually stayed home in the evenings after work, because I didn't make enough money to go out very much. And generally during the evening I'd tinker a little with Radio—a set of my own or some friend's. I even made a little spare change this way, which helped a lot, but I didn't know enough to go very far with such work.

And as for the idea that a splendid Radio job might be mine, if I made a little effort to prepare for it—such an idea never entered my mind. When a friend suggested it to me one year ago, I laughed at him.

"You're kidding me," I said.
"I'm not," he replied. "Take a look at this ad."

HE pointed to a page ad in a magazine, an advertisement I'd seen many times, but just passed up without thinking, never dreaming it applied to me. This time I read the ad carefully. It told of many big opportunities for trained men to succeed in the great new Radio field. With the advertisement was a coupon offering a big free book full of information. I sent the coupon in, and in a few days received a handsome 64-page book, printed in two colors, telling all about the opportunities in the Radio field, and how a man can prepare quickly and easily at home to take advantage of these opportunities. Well, it was a revelation to me. I read the book carefully, and when I finished it I made my decision.

What's happened in the twelve months since that day, as I've already told you, seems almost like a dream to me now. For ten of those twelve months, I've had a Radio business of my own. At first, of course, I started it as a little proposition on the side, under the guidance of the National Radio Institute, the outfit that gave me my Radio training. It wasn't long before I was getting so much to do in the Radio line that I quit my measly little clerical job and devoted my full time to my Radio business.

SINCE that time I've gone right on up, always under the watchful guidance of my friends at the National Radio Institute. They would have given me just as much help, too, if I had wanted to follow some other line of Radio besides building my own retail business—such as broadcasting, manufacturing, experimenting, sea operat-

ing, or any one of the score of lines they prepare you for. And to think that until that day I sent for their eye-opening book, I'd been wailing "I never had a chance!"

NOW I'm making, as I told you before, over \$100 a week. And I know the future holds even more, for Radio is one of the most progressive, fastest-growing businesses in the world today. And it's work that I like—work a man can get interested in.

Here's a real tip. You may not be as bad off as I was. But think it over—are you satisfied? Are you making enough money, at work that you like? Would you sign a contract to stay where you are now for the next ten years—making the same money? If not, you'd better be doing something about it instead of drifting.

This new Radio game is a live-wire field of golden rewards. The work in any of the 20 different lines of Radio is fascinating, absorbing, well paid. The National Radio Institute—oldest and largest Radio home-study school in the world—will train you inexpensively in your own home to know Radio from A to Z and to increase your earnings in the Radio field.

TAKE another tip—no matter what your plans are, no matter how much or how little you know about Radio—clip the coupon below and look their free book over. It is filled with interesting facts, figures, and photos, and the information it will give you is worth a few minutes of anybody's time. You will place yourself under no obligation—the book is free, and is gladly sent to anyone who wants to know about Radio. Just address J. E. Smith, President, National Radio Institute, Dept. 9PD, Washington, D. C.

**J. E. SMITH, President
National Radio Institute
Dept. 9PD, Washington, D. C.**
Dear Mr. Smith:

Please send me your 64-page free book, printed in two colors, giving all information about the opportunities in Radio and how I can learn quickly and easily at home to take advantage of them. I understand this request places me under no obligation, and that no salesman will call on me.

Name.....
Address.....
Town..... State.....
Occupation.....

TOBE

Filterette

STOPS RADIO NOISES

Filterette Junior Model



Tobe Filterette Junior Model is an ideal Filter for any small motor such as, motors on electric fans, hair dryers, barber clippers, vacuum cleaners, cash registers and similar devices. This unit plugs in line, and it is necessary only to run a small wire from the binding post on the Filterette to any part of the motor frame. Interference is eliminated at once.

Maximum potential.....110 volts A. C. or D. C.
Maximum load.....500 watts

Tobe Filterette Junior Model
List Price \$3.50

At a time when no other company had foreseen the possibilities of this field, the Tobe Deutschmann Company, recognizing the need for such a device, brought out (see N. Y. Sun for Dec. 11, 1926) the first interference filter. The present FILTERETTES, consequently, are the result of over two years' constant research and experiment on varied types of electrical apparatus. We are, to our knowledge, the only company devoting a completely equipped laboratory to the problem of radio interference elimination, and maintaining a staff of engineers constantly at work upon actual apparatus—oil burners, farm lighting equipment, sign flashers, adding machines, electric refrigerators, etc.

Filterette Sign Flasher Models



Tobe Filterettes in series 131 to 135 are designed for application to 110 volt motor driven sign flashers to suppress radio disturbances set up by the motor and rotary contacts of such flashers. These Filterettes may be used for any application, within the rating of the unit, which requires a combined inductive and capacitive type filter.

Filterette No. 131

Maximum potential.....110 volts A. C. or D. C.
Maximum current.....10 amperes
Maximum load.....1,000 watts
Outside dimensions 13x6³/₈x3³/₈"
Tobe Filterette No. 131.....List Price \$20.00

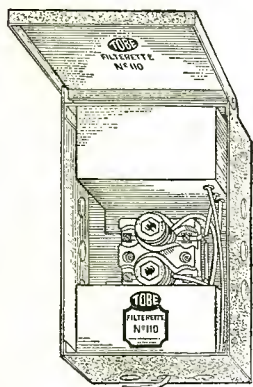

Filterette No. 110

Tobe Filterette No. 110 is designed for application to all types of 110 volt A. C. or D. C. electrical apparatus which require a combined inductive and capacitive type filter. This Filterette is required for certain types of refrigerators, oil burners, chargers, electric signs or blinkers, electric heating pads, dental motors and violet ray and diathermic machines.

Maximum potential.....110 volts A. C. or D. C.
Maximum current.....4.5 amperes
Maximum load.....500 watts

Outside dimensions 10x6³/₈x3¹/₈"

TOBE FILTERETTE NO. 110.....List Price \$15.00

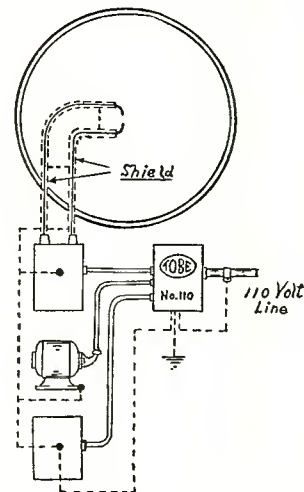

We hope that readers and their friends will take advantage of our offer placing at their disposal the services of our engineering staff. We shall be glad to forward each

month a copy of our monthly house organ devoted exclusively to this vital problem of radio interference.

Write for Filterette Bulletin C12 which describes entire line of Tobe Filterettes

TOBE DEUTSCHMANN CORPORATION

Canton, Mass.

Pioneers in Eliminating Interference Problems of Every Description

HOLLISTER[®] = AC 8

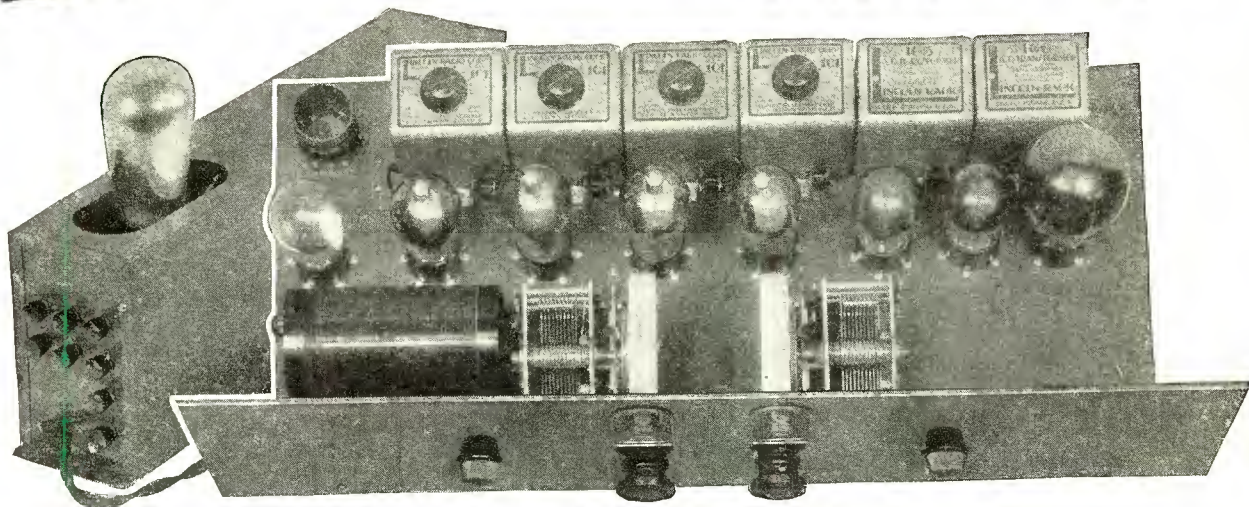

HERE IT IS!

The Set You Have Asked For — With All the Proved Performance of the
LINCOLN 8-80

TREMENDOUS POWER WITHOUT OSCILLATION—Tune where you will and Station after Station you never heard before will crash into your home with a volume you cannot get on local with the average receiver.

10 K. C. Selectivity Guaranteed
Marvelous Tone Quality—Clough System of Audio
Tunable Intermediates
High Sensitivity—2000 Miles on Ten Inch Antenna
New Highly Designed Illuminated Drum Dial and Condenser Assembly
One Spot Registration
Four A.C. Screen Grid Stages—425 Volt Output

Perfect Stability—No Squeals or Howls
Operated Complete from Small Compact Unit 3 7/16" x 5 1/4" x 16 1/8" Using One 381 Type Tube Only
Elegant Appearance—Finely Grained Walnut Bakelite Panel
Easy to Build
HOLLISTER AC 8 KIT.....PRICE \$110.00
HOLLISTER AB 250 POWER PACK..... " 60.00

LINCOLN 8-80 ONE SPOT SUPER D.C.

5,000 Miles With Loud Speaker Volume
Only One Refund Asked in Seven Months Production
Operated by Two Small Bone Dry Rectifiers

PROVEN BY HUNDREDS OF SET BUILDERS TO BE THE MOST POWERFUL RECEIVER ON THE MARKET

Lincoln 8-80 Kit.....Price \$92.65
Lincoln 110B..... " 43.50

Lincoln Engineering has been endorsed by hundreds of custom set builders. Our big volume of sales is directly due to the wonderful reputation gained THRU ACTUAL PERFORMANCE AND NOT ADVERTISED CLAIMS.

THE LINCOLN 8-80 HAS PIONEERED THE WAY FOR BETTER LONG DISTANCE RECEPTION

From Wankegan, Ill., comes the report of "every frequency logged from 500 KC to 1210 KC, except 880 and 1020 KC."

From the Hills of Kentucky—"300 stations logged in one week, 25 being on the West Coast, Mexico and Cuba, and many 50 and 100 watt stations."

From Battle Creek, Mich.—"No trouble getting CMC, Havana while KWKII is on the air, and KGO at Oakland, while KTIS and Winnipeg are on full blast."

LINCOLN RADIO CORPORATION 329 SOUTH WOOD ST. — CHICAGO - ILLINOIS.

Authorized Distributors for Lincoln 8-80

W. C. BRAUN CO.
563 W. Randolph St., Chicago
WESTERN RADIO MFG. CO.,
128 W. Lake St., Chicago
ELECTRIC & RADIO SUPPLY,
22 N. Franklin St., Chicago
CHICAGO RADIO APPARATUS,
415 S. Dearborn St., Chicago

LINCOLN RADIO CORP., Dept. C.
329 S. Wood St., Chicago.

.....Send me full information on your products for custom set builders.

.....I have never received one of your catalogs.

Name.....

Address.....

Authorized Distributors for Lincoln 8-80

KLADAG RADIO LABORATORIES,
Kline Bldg., Kent, Ohio
HENRY L. WALKER CO.,
27 E. Jefferson St., Detroit, Mich.
WEDEL CO.,
520 Second Ave., Seattle, Wash.
SHURE BROS.,
335 W. Madison St., Chicago

Tell 'Em You Saw It in the Citizens Radio Call Book Magazine and Scientific Digest

Citizens Radio Call Book Magazine

AND SCIENTIFIC DIGEST

Registered in U. S. Patent Office

Established 1921

Executive Offices:

508 So. Dearborn St., Chicago, Ill.

Member Audit Bureau of Circulations

C. O. STIMPSON, President
E. H. JAUDON, Vice-President
D. H. BELL, Secretary-Treasurer
H. ANHEISER, Assistant Treasurer

F. A. HILL, Managing Editor
RICHARD K. PEW, Technical Editor
C. B. BENSON, Advertising Manager
M. R. HARRIS, Circulation Manager

MARCH, 1929

Published January, March, September, November

Vol. 10, No. 2

CONTENTS THIS ISSUE

Roster of Columbia and N.B.C. Chain Stations	8
Up-to-the-Minute U. S. Broadcast Station List	3-23
U. S. Broadcast Stations by States	30
U. S. Broadcast Stations by Frequencies	32
Canadian Stations	34
Short Wave Phone and Telegraph Stations	34
Foreign Broadcast Stations	34
Foreign Broadcast Stations (continued)	35
Handy Log Chart	36
Ampere Andy's Assistors	38, 39, 40
S-M 720 a. c. Using Newest Tubes	44, 45, 46
Citizens 4 Tube Junior Receiver	47, 48
Aero International Four Receiver	49, 50
Citizens A. C. Booster Stage	51, 52
Hollister A. C. Superheterodyne	53, 54, 55
Citizens Wave Trap	56, 57
Citizens Tube Tester Design	58, 59, 60
Thordarson R-480 Power Amplifier	61
Simple D. C. "B" Eliminator	62
Walker Multi-Unit	63, 64
Robertson-Davis Super Six Receiver	65, 66
Hammarlund Short Wave Screen Grid Adapter	67, 68
Modulated Oscillator for the Service Man	69
Hammarlund-Roberts Hi-Q 29 Master A. C. Receiver	70, 71, 72
Power Amplification Section:	
Wiring of Homes for Radio Source of Profit for Service Man	73, 74, 75
S-M 690 Rack-and-Panel Amplifier	76
Professional Set Builder's Section:	
Laboratory Experimentation on B Eliminators	77, 78, 79
Filters as a Means of Reducing Interference	80
280 Rectifier Tester	81
D. C. Relay and Charger	82
Direct Current "A" Supply	83
Several Uses for the Photocell	84
Optional Connections for Muter Dynamic Speakers	85
Many Measurements Made with Grid Dip Meter	86, 87, 88, 89
ABC of Radio Section	90, 91
Service and Repair Notes	92, 93, 94, 95, 96
Practical Television	97, 98
New Flying Boat for Navy	99
Test Loop for Hoisting Subs	100
Hot Wire Measures Wind Speed	101
Float Bridge Span Into Position	102
Tiny Furnace Develops Great Heat	103
With the Accessory and Parts Manufacturers	104, 105
Questionnaire Page	117
Blue Print Page	152
Index to Advertisers	158

In This Issue

TWO new departments have been added to this magazine in response to requests from our readers. One of the departments is the Power Amplification Section, beginning on page 73, and the other is Service and Repair Notes beginning on page 92. We are quite anxious to learn the opinions of our readers with respect to these two new departments, and with this in mind we would like to call your attention to the questionnaire form which will be found on page 117. By properly filling out this questionnaire in accordance with your own ideas on the subject, you can give us valuable data on which to base our editorial activities for the ensuing season.

Readers will perhaps observe that in this issue there are a large number of small jobs described in laboratory parlance as "gadgets." These represent to a considerable extent design work made especially in response to a number of inquiries from our correspondents. We would also be interested in knowing how you like the various "gadgets" and you may express your opinions on the questionnaire referred to above.

Two new tubes have made their appearance. Both have passed the laboratory stages and as the reader glances over this column the tubes will most likely be on the market. The first is known as the UY-224, a five-prong a. c. screen grid tube, anxiously awaited for many moons by the radio industry. The second tube, none the less anxiously hoped for, is an intermediate power tube known as the UX-245, which delivers extremely fine undistorted output at nominal plate voltages. More data concerning these two tubes will be found in the article describing the Silver-Marshall 720 a. c. on pages 44, 45 and 46. With the arrival of these tubes, we may look for interesting developments in completely alternating current operated receivers.

The Editor.

Copyright, 1929, by Citizens Radio Service Bureau, Incorporated, Publishers. Requests for permission to reprint any articles or other matter contained herein must be made in writing to the executive offices.

Citizens Radio Call Book Magazine is published four times a year and is on sale approximately the first of January, March, September and November. Subscription price \$1.75 per year in U. S. A. Canada and Foreign \$2.00 per year, payable in advance. Single copies 50 cents. Remit by check, draft or P. O. order. No foreign stamps or coins accepted. Mail subscriptions to 508 So. Dearborn Street, Chicago. We will not be responsible for cash sent for subscriptions unless registered.

Citizens Radio Call Book Magazine is for sale on all newsstands in the United States and Canada; also Department Stores and Book Stores; also can be purchased in most radio stores. Paris, France, Brentanos, Ave de L'Opera. England, R. A. Rothermel, Ltd., 24-26 Maddox St., Regent St., London, and W. H. Smith & Sons, London. Australia, McGills Agency, 179 Elizabeth St., Melbourne.

Advertising Representatives:

Chicago—A. B. Mills, 508 So. Dearborn St. Wabash 1901.
New York—(Branch Office)—154 W. 42nd St. Longacre 1063.

Entered as second class matter November 15, 1928, at the Postoffice at Chicago, Illinois, under the act of March 3, 1879

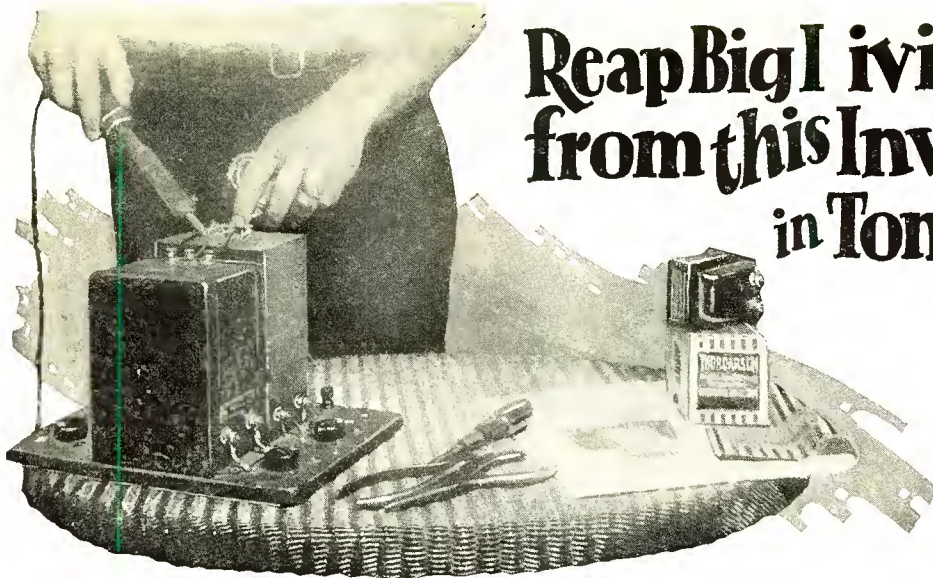

Reap Big Dividends from this Investment in Tone Quality

A Thordarson Power Amplifier (Home Constructed) Will Transform Your Radio Into a Real Musical Instrument

WITH the insistent demand for quality reproduction, power amplification has become a vital radio necessity. Today, it is hard to find a radio set manufacturer who does not employ one or more power tubes in the output stage of his receiver.

There is no need, however, for you to discard your present radio instrument in spite of the fact that it is outclassed by newer models with power amplification. You can build a Thordarson Power Amplifier which, attached to your receiver, will provide a fullness and richness of reproduction that will equal or surpass the finest offerings of the present season.

Thordarson Power Amplifiers are exceedingly easy to assemble, even for the man with no previous radio experience. Only the simplest tools are used. Specific instructions with clear-cut photographs, layouts and diagrams insure success in home construction.

Whether your present receiver is factory made or custom built one of these amplifiers may be attached with equal ease. In fact, most Thordarson Amplifiers require absolutely no changes in

the wiring of the receiver itself, attachment being made by means of a special plug which fits the last audio socket of the receiver.

Thordarson Power Amplifiers for the home constructor and professional set builder range from the simple plate supply unit up to the heavy-duty three stage units employing the 250 type power tube in push-pull arrangement. These power amplifiers cover the requirements for every purpose and every pocket-book. They may be used with any type of horn, cone or dynamic speaker.

With a background of over thirty-three years manufacturing quality transformers, it is only natural that so many manufacturers of receiving sets of undisputed superiority have turned to Thordarson as the logical source of their audio and power supply transformers. The discriminating home constructor will do well to follow the lead of these manufacturers when buying his power amplifier.

Write to the factory today, enclosing 25c for the new "Power Amplifier Manual"—just off the press.



New!

No Amateur or Professional Set Builder Should Be Without This Book—

"POWER AMPLIFIER MANUAL"

A simple, yet complete, treatise on the subject of audio and power amplification, including full information on building, servicing, and testing power amplifiers in general. Also contains detailed specific construction data on twelve individual power units, with clear-cut layouts and diagrams of each.

25c

Send 25c in Cash or Stamps for This New Book—
Just Off the Press!

MAIL THIS COUPON TO-DAY!

THORDARSON ELECTRIC MANUFACTURING CO.
500 West Huron Street, Chicago, Illinois

Gentlemen: Please send me your new "Power Amplifier Manual" for which I am enclosing 25c.

Please send me free of charge your instruction sheet on the amplifier I have checked below:

171 Single 171 Push-Pull 210 Single 210 Push-Pull (1 Stage) 210 Push-Pull (2 Stage) 250 Single (1 Stage) 250 Single (2 Stage) 250 Push-Pull (3 Stage) 210 Phonograph Amplifier

Name.....

Street and No.....

Town..... State.....

8586 A

THORDARSON RADIO TRANSFORMERS

SUPREME IN MUSICAL PERFORMANCE

Tell 'Em You Saw It in the Citizens Radio Call Book Magazine and Scientific Digest

American Broadcasting Stations

Station assignments shown in the following pages were made by the Federal Radio Commission. This list is revised from issue to issue and is therefore up-to-the-minute. Initials such as E, C, M, and P denote Eastern, Central, Mountain and Pacific time.

Stations associated with the Columbia Broadcasting System: WABC, 2XE, WOR, WEAN, WNAC, WCAU, WFAN, WCAO, WFBL, WMAK, WKBW, WLBW, WJAS, WHK, WADC, WMAL, WSPD, WKRC, WGHP, WOWO, WGL, WMAQ, WBBM, KMOX, KMBC, KOIL, WDBJ, WTAR, WWNC, WLAC, WDOD, WBRC, WREC, KFJF, KFH, KRLD, KTSA, KRLA, KLZ, KDYL, KYA, KMTR, KJR, KEX, KGA, WCCO, WISN, WDSU.

Stations associated with the National Broadcasting System: WEAJ, WJZ, WEEL, WBZA, WBZ, WTIC, WJAR, WTAG, WCSH, WFI, WLIT, WRC, WBAL, WGY, WGR, WHAM, WCAE, KDKA, WTAM-WEAR, WWJ, WJR, WLW-WSAI, WGN-WLIB, WENR, WLS, KYW-KFKX, KSD, KWK, WOC, WHO, WOW, WDAF, WREN, KSTP, WTMJ, KOA, WHAS, WSM, WMC, WSB, WBT, KVOO, WFAA, KPRC, WOAI, WBAP, WRVA, WJAX, KPO, KGO, KFI, KGW, KOMO, KHQ, WEBC, KSL, WKY.

- KDB**
1500 kc, Santa Barbara, Calif., Santa Barbara Broadcasting Co., 100 w, P.
- KDKA**
980 kc, East Pittsburgh, Pa., Westinghouse E. & M. Co., 50,000 w, E.
- KDLR**
1210 kc, Devils Lake, N. D., Radio Electric Co., 100 w.
- KDYL**
1290 kc, Salt Lake City, Utah, Intermountain Broadcasting Corp., 1000 w, M, "On the Air, Goes Everywhere. Shared.
- KEKJ**
1170 kc, Beverly Hills, Calif., R. C. MacMillan, 500 w, P. Shared.
- KELW**
780 kc, Burbank, Calif., Earl L. White, 500 w, P, "The White Spot of the San Fernando Valley." Shared.
- KEX**
1180 kc, Portland, Ore., Western Broadcasting Co., 5000 w, P, "A Public Service Necessity." Shared.
- KFAB**
770 kc, Lincoln, Neb., Nebraska Buick Automobile Co., 5000 w, C, "Home, Sweet Home." Shared.
- KFAD**
620 kc, Phoenix, Ariz., Electric Equipment Co., 500 w, M, "Phoenix, Where Winter Never Comes."
- KFBB**
1360 kc, Great Falls, Mont., F. A. Buttrey Co., 250 w., M.
- KFBK**
1310 kc, Sacramento, Calif., James McClatchy Co., 100 w, P.
- KFBL**
1370 kc, Everett, Wash., Leese Bros., 50 w, P, "The Voice of Puget Sound." Shared.
- KFCB**
1310 kc, Phoenix, Ariz., Nielsen Radio Supply Co., 100 w, M, "Kind Friends Come Back."
- KFDM**
560 kc, Beaumont, Tex., Magnolia Petroleum Co., 500 w, C, "Kall for Dependable Magnolene." Shared.
- KFDY**
550 kc, Brookings, S. D., State College, 500 w, C. Shared.
- KFEC**
1370 kc, Portland, Ore., Meier & Frank Co., 50 w, P, "Known for Every Courtesy." Shared.
- KFEL**
940 kc, Denver, Col., Eugene P. O'Fallon, Inc., 250 w, M, "The Argonaut Station." Shared.
- KFEQ**
560 kc, St. Joseph, Mo., Scroggin & Co., 2500 w, C. Shared.
- KFGQ**
1310 kc, Boone, Iowa, Boone Biblical College, 100 w, P.
- KFH**
1300 kc, Wichita, Kan., Hotel Lassen, 1000 w, C, "Kansas' Finest Hotel, in the Very Heart of God's Country." Shared.
- KFHA**
1200 kc, Gunnison, Colo., Western St. College of Colorado, 50 w.
- KFI**
640 kc, Los Angeles, Calif., Earl C. Anthony, Inc., 5000 w, P, "National Institution."
- KFIF**
1420 kc, Portland, Ore., Benson Polytechnic School, 100 w, P.
- KFIO**
1230 kc, Spokane, Wash., North Central High School, 100 w day, P.
- KFIU**
1310 kc, Juneau, Alaska, Alaska Electric Light & Power Co., 10 w, "A Voice From the Far North."
- KFIZ**
1420 kc, Fond du Lac, Wisc., Fond du Lac Commonwealth Reporter, 100 w, C.
- KFJB**
1200 kc, Marshalltown, Iowa, Marshall Electric Co., 100 w, C, "Marshalltown, the Heart of Iowa."
- KFJF**
1470 kc, Oklahoma City, Okla., National Radio Mfg. Co., 5000 w, C, "Radio Headquarters of Oklahoma. Shared.
- KFJI**
1370 kc, Astoria, Ore., Geo. Kincaid, 50 w, P. Shared.
- KFJM**
1370 kc, Grand Forks, N. D., University of North Dakota, 100 w, C. Shared.
- KFJR**
1300 kc, Portland, Ore., Ashley C. Dixon & Son, 500 w, P. Shared.
- KFJY**
1310 kc, Ft. Dodge, Iowa, C. S. Tunwal, 100 w, C. Shared.
- KFJZ**
1370 kc, Ft. Worth, Texas, Henry Clay Allison, 100 w, C.
- KFKA**
880 kc, Greeley, Colo., Colorado State Teachers College, 500 w, M. Shared.
- KFKB**
1130 kc, Milford, Kan., KFKB Broadcasting Ass'n, 5000 w, C, "The Sunshine Station in the Heart of the Nation."
- KFKU**
1220 kc, Lawrence, Kan., University of Kansas, 1000 w, C, "Up at Lawrence on the Kaw." Shared.
- KFKX**
See under KYW.
- KFKZ**
1200 kc, Kirksville, Mo., Northeast Missouri State Teachers College, 50 w, C, "Kirksville, the Home of Osteopathy."
- KFLV**
1410 kc, Rockford, Ill., A. T. Frykman, 500 w, C. Shared.
- KFLX**
1370 kc, Galveston, Texas, Geo. Roy Clough, 100 w, C.
- KFMX**
1250 kc, Northfield, Minn., Carleton College, 1000 w, C. Shared.
- KFNF**
890 kc, Shenandoah, Iowa, Henry Field Seed Co., 500 w, C, "Known for Neighborly Folks." Shared.

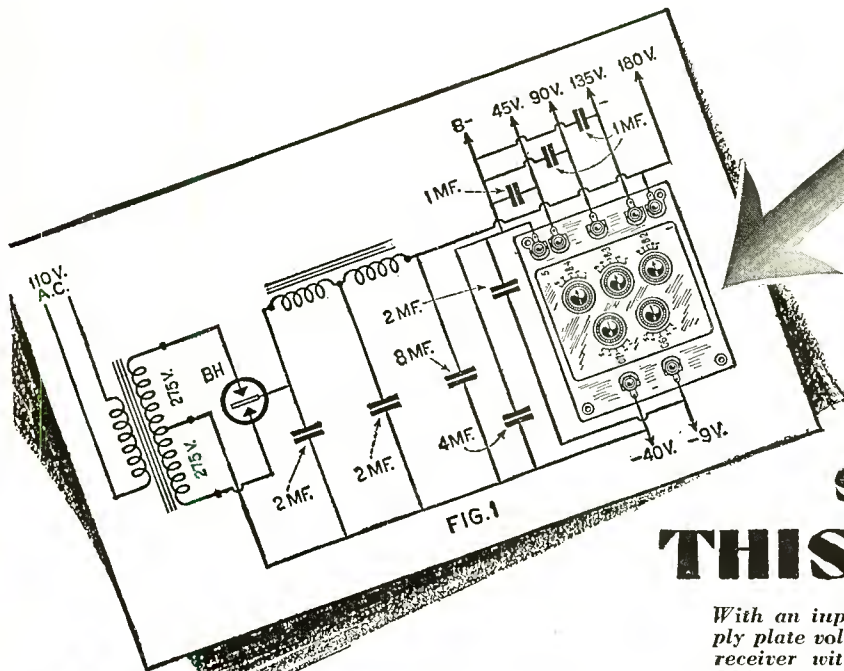

WHAT is the simplest solution to THIS PROBLEM?

With an input voltage of 220—required; to supply plate voltages and grid bias to a six-tube T.R.F. receiver with one 201-A tube at 45 volts, three 201-A tubes at 90 volts, one 112-A tube at 135 volts, one 171 tube at 180 volts and grid biases of -9 and -40 volts?

Answer:-

The TRUVOLT DIVIDER

THE Truvolt Divider is a *universal resistor*. It eliminates the use of a special resistance for each required voltage. By simply connecting it to the output terminals of the filter circuit of the eliminator, the Truvolt Divider will deliver proper plate and grid voltages to any receiver of present or anticipated future design.

The Truvolt Divider uses a wire-wound resistor having five variable taps. Referring to the diagram above, a maximum fixed voltage of approximately 180 volts is obtained from binding post number 1; tap B-2 will supply any voltage from 160 to 110, tap B-3 any voltage from 110 to 65, tap B-4 any voltage from 55 to 20. The grid bias tap C-6 will supply a grid bias of from -1 to -20 volts, and tap C-7 a bias voltage of from -20 to -40.

Each of the Divider's taps is *calibrated* and practically any desired voltage variations can be obtained by adjusting the various knobs in accordance with easily understood tables and charts, thus eliminating the need of an expensive high resistance voltmeter and complicated calculations.

The Truvolt Divider is handsome in appearance, made of genuine Bakelite, and can be mounted in any desired position on baseboard or sub-panel, or used as a front panel on a metal cabinet, at the same time providing binding posts for all B and C voltages.

Electrad specializes in a complete line of controls for all radio purposes, including Television.

\$ 12.50

U. S. Patent No. 1676869 and Patents Pending

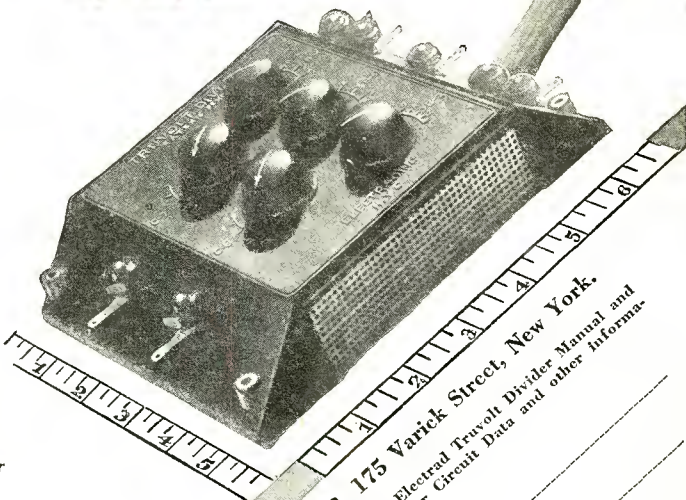

175 Varick Street, New York
ELECTRAD
 INC.

ELECTRAD, INC., Dept. CR3, 175 Varick Street, New York.

Please send me Free copy of Electrad Truvolt Divider Manual and put me on your mailing list for Circuit Data and other information.

Name _____ Address _____ City _____ State _____

Tell 'Em You Saw It in the Citizens Radio Call Book Magazine and Scientific Digest

KFOR

1210 kc, Lincoln, Neb., Howard A. Shuman, 100 w, C.

KFOX

1250 kc, Long Beach, Calif., Nichols & Warriner, Inc., 1000 w, P, "Where Your Ship Comes In." Shared.

KFPL

1310 kc, Dublin, Texas, C. C. Baxter, 15 w, C, "Baxter's Place."

KFPM

1310 kc, Greenville, Texas, The New Furniture Co., 15 w, C, "Biggest Little Ten Watts on the Air."

KFPW

1340 kc, Siloan Springs, Ark., Rev. Lannie W. Stewart, 50 w.

KFPY

1390 kc, Spokane, Wash., Symons Investment Co, 500 w, P.

KFQA

See under KMOX.

KFQD

1230 kc, Anchorage, Alaska, Anchorage Radio Club, 100 w, Shared.

KFQU

1420 kc, Holy City, Calif., W. E. Riker, 100 w, P, Shared.

KFQW

1420 kc, Seattle, Wash., KFOW, Inc., 100 w, P, "Gateway to Alaska and the Orient." Shared.

KFQZ

850 kc, Hollywood, Calif., Leslie E. Taft, 250 w, P.

KFRC

610 kc, San Francisco, Calif., Don Lee, Inc., 1000 w, P.

KFRU

630 kc, Columbia, Mo., Stephens College, 500 w, C, "Where Friendliness is Broadcast Daily." Shared.

KFSD

600 kc, San Diego, Calif., Airfan Radio Corp., 500 w, P.

KFSG

1120 kc, Los Angeles, Calif., Echo Park Evan. Assn., 500 w, P, "The Church of the Air."

KFUL

1290 kc, Galveston, Texas, W. H. Ford, 500 w, C, "The City of Perpetual Sunshine."

KFUM

1270 kc, Colorado Springs, Colo., W. D. Corley, 1000 w, M, "Known for Unsurpassed Mountain Scenery." Shared.

KFUO

550 kc, St. Louis, Mo., Concordia Theological Seminary, 500 w, C, "The Gospel Voice." Shared.

KFUP

1310 kc, Denver, Colo., Fitzsimmons General Hospital, 100 w, M.

KFUR

1370 kc, Ogden, Utah, Peery Building Co., 50 w, M.

KFVD

700 kc, Culver City, Calif., W. J. McWhinnie, 250 w, P.

KFVS

1210 kc, Cape Girardeau, Mo., Hirsch Battery & Radio Co., 100 w, C, "The City of Opportunity." Shared.

KFWB

950 kc, Los Angeles, Calif., Warner Bros. Broadcasting, 1000 w, P, Shared.

KFWC

1200 kc, Ontario, Calif., J. R. Fouche, 100 w, P, "The Voice of the Orange Empire." Shared.

KFWF

1200 kc, St. Louis, Mo., St. Louis Truth Center, Inc., 100 w, Shared.

KFWI

930 kc, San Francisco, Calif., Radio Entertainments, Inc., 500 w, P, Shared.

KFWM

930 kc, Oakland, Calif., Oakland Educational Society, 500 w, P, "The Most Good to the Most People." Shared.

KFXD

1420 kc, Jerome, Idaho, Service Radio Co., 50 w, M.

KFXF

940 kc, Denver, Colo., Pikes Peak Broadcasting Co., 250 w, M, "The Voice of Denver." Shared.

KFXJ

1310 kc, Edgewater, Colo., R. G. Howell, 50 w, M, "America's Scenic Center." Shared.

KFXR

1310 kc, Oklahoma City, Okla., Exchange Avenue Baptist Church, 100 w, C.

KFXY

1420 kc, Flagstaff, Ariz., Mary M. Costigan, 100 w, M.

KFYO

1420 kc, Abilene, Texas, T. E. Kirksey, 100 w, C, "Breckenridge, the Dynamo of Wet Texas."

KFYR

550 kc, Bismarck, N. D., Hoskins-Meyer, 500 w, C, Shared.

KGA

1470 kc, Spokane, Wash., Northwest Radio Service Co., 5000 w, P.

KGAR

1370 kc, Tucson, Ariz., Tucson Motor Service Co., 100 w, M, "Way Out on the Desert."

KGB

1360 kc, San Diego, Calif., Pickwick Broadcasting Corp., 250 w, P, "Music for the Sick."

KGBU

900 kc, Ketchikan, Alaska, Alaska Radio & Service Co., 500 w, Shared.

KGBX

1370 kc, St. Joseph, Mo., Foster-Hall Tire Co., 100 w.

KGBZ

930 kc, York, Nebr., Geo. R. Miller, 500 w, C, "The Swine and Poultry Station." Shared.

KGCA

1270 kc, Decorah, Iowa, Chas. W. Greenley, 50 w, C, Shared.

KGCB

1370 kc, Enid, Okla., Champlain Refining Co., 100 w, C, Shared.

KGCI

1370 kc, San Antonio, Texas, Liberto Radio Sales, 100 w, C, "Radio Sam at San Antonio."

KGCN

1420 kc, Concordia, Kan., Concordia Broadcasting Co., 50 w.

KGCR

1210 kc, Brookings, S. D., Cutler's Radio Broadcasting Service, Inc., 100 w.

KGCU

1200 kc, Mandan, N. D., Mandan Radio Association, 100 w, M, "The Voice of the West."

KG CX

1420 kc, Vida, Mont., First State Bank of Vida, 10 w, M.

KGDA

1370 kc, Dell Rapids, S. D., Home Auto Co., 50 w.

KGDE

1200 kc, Fergus Falls, Minn., Jaren Drug Co., 50 w, C.

KGDM

1150 kc, Stockton, Calif., E. F. Pepper, 50 w.

KGDR

1500 kc, San Antonio, Texas, Joe B. McChane, 100 w, C.

KG DY

1200 kc, Oldham, S. Dak., J. Albert Loesch, 15 w, C.

KG EF

1300 kc, Los Angeles, Calif., Trinity Methodist Church, 1000 w, P, Shared.

KG EK

1200 kc, Yuma, Colo., Beshler Elec. Equip. Co., 50 w, M, Shared.

KG ER

1370 kc, Long Beach, Calif., C. Marwin Dobyns, 100 w, P, "The Service Club of the Air."

KG EW

1200 kc, Ft. Morgan, Colo., City of Ft. Morgan, 100 w, P, Shared.

KG EZ

1310 kc, Kalispell, Mont., Flathead Broadcasting Association, 100 w, M, "Located in the Switzerland of America—The Beautiful Flathead Valley."

Back in APRIL
1928 - - -



The screen grid tube using the separate heater principle and requiring 1.75 amps at 2.5 volts.

Do not miss CeCo's entertaining radio broadcast each Monday evening at 8:30 Eastern time (7:30 Central time) over the Columbia Broadcasting System.

EC announced the Type AC-22 Screen Grid Tube

using the separate heating principle and operating on 1.75 amps at 2.5 volts. It is now considered the most outstandingly successful AC amplifier and its use will be general this year.

This type of pioneering is characteristic of the effort which CeCo laboratories constantly exert in making available to radio engineers and experimenters the correct tubes for use in each new radio development.

It is pleasing to know that those who are responsible for the progress of radio look with increasing confidence to CeCo laboratories for each new improvement in radio tube design . . . which, after all, is a reward not to be measured in dollars and profits.

CeCo MANUFACTURING CO., INC.
Providence, R. I.

EC - Millions · in use

Tell 'Em You Saw It in the Citizens Radio Call Book Magazine and Scientific Digest

- KGFF**
1420 kc, Alva, Okla., Earl E. Hampshire, 100 w, C.
- KGFG**
1370 kc, Oklahoma City, Okla., Faith Tabernacle Assn., 100 w, C, "The Whole Gospel to the Whole World."
- KGFH**
1000 kc, Glendale, Calif., Frederick Robinson, 250 w, P.
- KGFI**
1310 kc, San Angelo, Texas, San Angelo Broadcasting Co., 100 w, C, "The Voice of West Texas."
- KGFJ**
1420 kc, Los Angeles, Calif., Ben S. McGlashan, 100 w, P, "Keeps Good Folks Joyful."
- KGFK**
1200 kc, Hallock, Minn., Kittson County Enterprise, 50 w, C.
- KGFL**
1370 kc, Raton, N. Mex., Hubbard & Murphy, 50 w, M.
- KGFW**
1420 kc, Ravenna, Neb., Otto F. Sothman, 50 w.
- KGFX**
580 kc, Pierre, S. D., Dana McNeil, 200 w daytime, C.
- KGGF**
1010 kc, Picher, Okla., D. L. Connell, M.D., 500 w, Shared.
- KGGH**
1310 kc, Cedar Grove, La., Bates Radio & Electric Co., 50 w, C.
- KGGM**
1370 kc, Albuquerque, N. Mex., Jay Peters, 100 w.
- KGHB**
1320 kc, Honolulu, Hawaii, Radio Sales, 250 w.
- KGHD**
1420 kc, Missoula, Mont., Elmore-Nash Broadcasting Co., 50 w, M.
- KGHF**
1320 kc, Pueblo, Colo., Ritchie & Finch, 250 w, M.
- KGHG**
1310 kc, McGehee, Ark., Chas. W. McCollum, 50 w.
- KGHI**
1500 kc, Little Rock, Ark., Berean Bible Class, 100 w.
- KGHL**
950 kc, Billings, Mont., Northwestern Auto Supply Co., 500 w, M.
- KGHX**
1500 kc, Richmond, Tex., Ft. Bend County School Board, 50 w, C.
- KGIO**
1320 kc, Idaho Falls, Ida., Jack W. Duckworth, Jr., 250 w, M. Shared.
- KGIQ**
1320 kc, Twin Falls, Ida., Stanley M. Soule, 250 w, M. Shared.
- KGIR**
1360 kc, Butte, Mont., Symons Broadcasting Co., 250 w, M. Shared.
- KGIW**
1420 kc, Trinidad, Colo., Trinidad Creamery Co., 100 w, M.
- KGJF**
890 kc, Little Rock, Ark., First Church of the Nazarene, 250 w.
- KGKB**
1500 kc, Brownwood, Tex., Eagle Publ. Co., 100 w, C.
- KGKL**
1370 kc, San Angelo, Tex., KGKL, Inc., 100 w, C.
- KGKO**
570 kc, Wichita Falls, Tex., Wichita Falls Broadcasting Co., 250 w, C.
- KGKX**
1420 kc, Sandpoint, Idaho, C. E. Twiss, 15 w, P.
- KGO**
790 kc, Oakland, Calif., General Electric Co., 7500 w, P.
- KGRC**
1370 kc, San Antonio, Texas, Gene Roth & Co., 100 w, C.
- KGRS**
1410 kc, Amarillo, Texas, Gish Radio Service, 1000 w, C. Shared.
- KGTT**
1420 kc, San Francisco, Calif., Golden Gate Broadcasting Co., 50 w, P, "Voice of Glad Tidings." Shared.
- KGU**
940 kc, Honolulu, Hawaii, Marion Mulrony, 500 w. "In the Land of Sunshine, the Future Playground of America."
- KGW**
620 kc, Portland, Ore., Oregonian Pub. Co., 1000 w, P, "Keep Growing Wiser."
- KGY**
1200 kc, Lacey, Wash., St. Martins College, 10 w, P, "Out Where the Cedars Meet the Sea." Shared.
- KHJ**
900 kc, Los Angeles, Calif., Don Lee, Inc., 1000 w, P, "Kindness, Happiness, Joy."
- KHQ**
590 kc, Spokane, Wash., Louis Wasmer, Inc., 1000 w, P, "In the Friendly City."
- KICK**
1420 kc, Red Oak, Iowa, Red Oak Radio Corp., 100 w daytime. Shared.
- KIDO**
1250 kc, Boise, Idaho, F. L. Hill & C. G. Phillips, 1000 w, P.
- KJBS**
1100 kc, San Francisco, Calif., Julius Brunton & Sons Co., 100 w, P, "The Voice of the Storage Battery." Shared.
- KJR**
970 kc, Seattle, Wash., Northwest Radio Service Co., 5000 w, P.
- KKP**
1370 kc, Seattle, Wash., City of Seattle, 15 w, P. Shared.
- KLCN**
1290 kc, Blytheville, Ark., C. L. Lintzenich, 50 w, C.
- KLDS**
See under KMBC.
- KLRA**
1390 kc, Little Rock, Ark., Arkansas Broadcasting Co., 1000 w. Shared.
- KLS**
1440 kc, Oakland, Calif., Warner Bros., 250 w, P, "The City of Golden Opportunity." Shared.
- KLX**
880 kc, Oakland, Calif., Tribune Pub. Co., 500 w, P, "Where Rail and Water Meet." Shared.
- KLZ**
560 kc, Dupont, Colo., Reynolds Radio Co., Inc., 1000 w, M, "The Pioneer Station of the West."
- KMA**
930 kc, Shenandoah, Iowa, May Seed & Nursery Co., 500 w, C, "Keeps Millions Advised." Shared.
- KMBC**
950 kc, Independence, Mo., Midland Broadcasting Co., 500 w, C, "The Station Dedicated to Knowledge, Liberty, Divinity and Service." Shared.
- KMED**
1310 kc, Medford, Ore., W. J. Virgin, 50 w, P, "See Crater Lake."
- KMIC**
1120 kc, Inglewood, Calif., James R. Fouch, 500 w, P.
- KMJ**
1200 kc, Fresno, Calif., The Fresno Bee, 100 w, P.
- KMMJ**
740 kc, Clay Center, Neb., The M. M. Johnson Co., 1000 w daytime, C, "The Old Trusty Station."
- KMO**
1340 kc, Tacoma, Wash., KMO, Inc., 500 w, P. Shared.
- KMOX**
1090 kc, Kirkwood, Mo., Voice of St. Louis, Inc., 5000 w, C.
- KMTR**
570 kc, Hollywood, Calif., KMTR Radio Corp., 500 w, P, "Your Friend in Hollywood." Shared.
- KNX**
1050 kc, Hollywood, Calif., Western Broadcast Co., 5000 w, P, "The Voice of Hollywood."
- KOA**
830 kc, Denver, Colo., General Electric Co., 12,500 w, M.
- KOAC**
560 kc, Corvallis, Ore., Oregon State Agricultural College, 1000 w, P, "Science for Service." Shared.

A NEW CATALOG JUST OFF THE PRESS

**164
PAGES
of RADIO
VALUES**

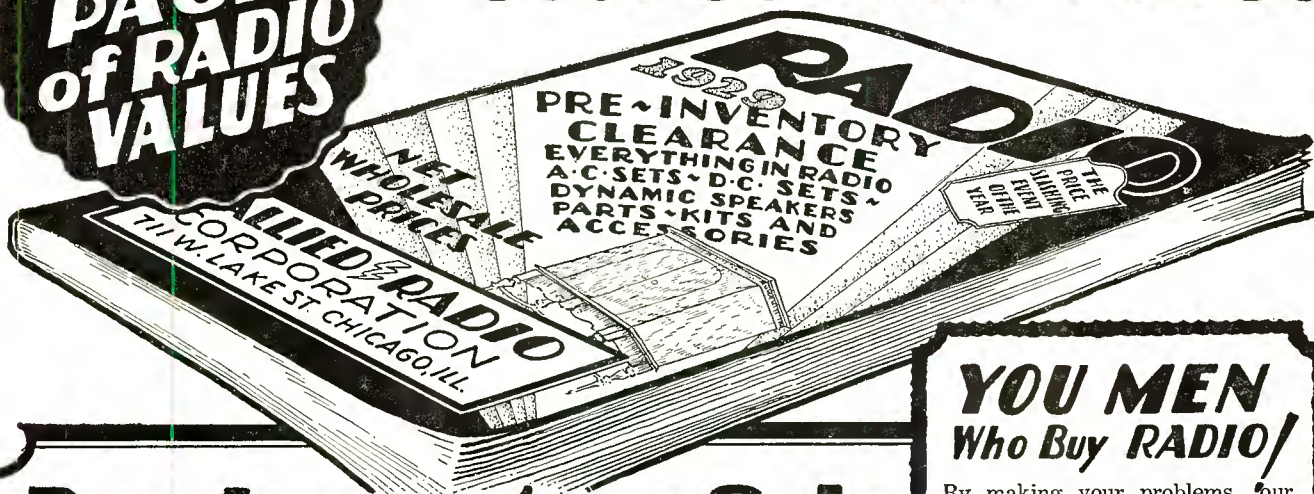

YOU MEN Who Buy RADIO!

By making your problems our problems, we know the service you require—and to render you such service the entire Allied organization is dedicated—to give you the service you have a right to expect. Tremendous stocks, remarkable values and a real desire to serve, all combine to make Allied your ideal source of supply.

Pre-Inventory Sale

A PRE-INVENTORY SALE featuring some of the most drastic price reductions of the season. Our tremendous stocks must be **reduced**. Prices have been cut to the bone. Everything in our large stocks of radio merchandise is included. You will marvel at the remarkable values. Now is the time to buy. A new large catalog, featuring these remarkable values is now ready. Every radio enthusiast—every dealer—every set builder should send for this new catalog—quoting **lowest wholesale prices** on **everything** in radio.

SET BUILDERS!

Set Builders, Amateurs and so called "Hams" will delight in the *unusual variety*—and **remarkable values** that are offered in standard kits and parts. Tremendous stocks—**real organization**—prompt shipping service all combine to make Allied your ideal source of supply.

RADIO DEALERS!

The live radio dealer—the man who keeps pace with the rapid advance of radio will find much of **real interest** in the Allied Catalog. New A-C Sets, D-C Sets, Dynamic and Magnetic Speakers, television equipment, in fact **everything** that an impatient radio public is demanding.

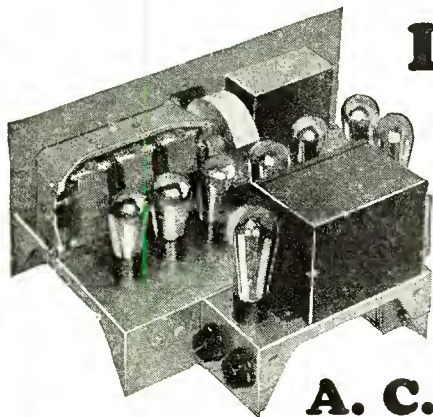

A. C.

ELECTRIC SETS

Allied offers you a new—complete line of A-C Receivers, available in either chassis form or in a wide variety of beautiful console models. Prices range from \$32.95 to \$199.00. Dollar for dollar they stand out as one of the season's leading receivers. Engineered to unusual perfection they offer you features found only in the highest priced sets.

Lowest Wholesale Price

Allied Service will prove a revelation to you in what radio service can really be. Allied Executives backed by years of training in radio are practical men. They know radio. Their vast experience has built up around them an organization trained to serve. Months of effort have built up here a tremendous reserve of stock that makes for prompt shipments; and this stock is new stock comprising the seasons pick of such prominent manufacturers as Silver-Marshall, Tyrman, Aero, Hammerlund-Roberts, etc.

You Profit When You Buy Right

Buying right is half the battle. From the small set builder to the large dealer, your success depends upon gauging the public pulse of radio and in **buying right**. Everything that is new in radio—the items the radio public is now demanding are here, ready for your call. Write now—the catalog is **free** for the asking.

Write for Catalog Now

Allied Radio
CORPORATION
711 W. LAKE ST. Dept. C-3, CHICAGO, ILL.

KOB

1180 kc. State College, N. M., N. M. College of Agri. & Mech. Arts, 10,000 w. M., "The Sunshine State of America." Shared.

KOCW

1420 kc. Chickasha, Okla., Okla. College for Women, 100 w. C.

KOH

1370 kc, Reno, Nevada, Jay Peters, Inc., 100 w.

KOIL

1260 kc, Council Bluffs, Iowa, Mona Motor Oil Co., 1000 w, C, "The Hilltop Studio."

KOIN

940 kc. Portland, Ore., KOIN, Inc., 1000 w, P, "The Station of the Hour."

KOL

1270 kc, Seattle, Wash., Seattle Broadcasting Co., 1000 w, P. Shared.

KOMO

920 kc, Seattle, Wash., Fisher's Blend Station, Inc., 1000 w, P.

KOOS

1370 kc, Marshfield, Ore., H. H. Hanseth, 50 w, P.

KORE

1420 kc, Eugene, Ore., Eugene Broadcast Station, 100 w, P.

KOW

1390 kc, Denver, Colo., Associated Industries, Inc., 500 w. M, "The KOW Station Away Out West." Shared.

KPCB

1210 kc, Seattle, Wash., Pacific Coast Biscuit Co., 100 w, P. Shared.

KPJM

1500 kc, Prescott, Ariz., Frank Wilburn, 100 w, M.

KPLA

576 kc, Los Angeles, Calif., Pacific Development Radio Co., 1000 w, P. Shared.

KPO

680 kc, San Francisco, Calif., Hale Bros. & The Chronicle, 5000 w, P, "The City of the Golden Gate."

KPOF

880 kc, Denver, Colo., Pillar of Fire, Inc., 500 w. M. Shared.

KPPC

1200 kc, Pasadena, Calif., Pasadena Presbyterian Church, 50 w, P. Shared.

KPQ

1210 kc, Seattle, Wash., Archie Taft & Louis Wasmer, 100 w, P.

KPRC

920 kc, Houston, Texas, Houston Printing Co., 1000 w. C, "Kotton Port Rail Center." Shared.

KPSN

950 kc, Pasadena, Calif., Pasadena Star-News, 1000 w, P. Shared.

KPWF

1490 kc, Westminster, Calif., Pacific Western Broadcasting Federation, 5,000 w, P.

KQV

1380 kc, Pittsburgh, Pa., Doubleday-Hill Elec. Co., 500 w, E, "The Smoky City Station." Shared.

KQW

1010 kc, San Jose, Calif., First Baptist Church, 500 w, P, "For God and Country."

KRE

1370 kc, Berkeley, Calif., First Congregational Church, 100 w, P. Shared.

KRGV

1260 kc, Harlingen, Texas, Harlingen Music Co., 500 w. Shared.

KRLD

1040 kc, Dallas, Texas, KRLD, Inc., 10,000 w, C. "Down Where the Blue Bonnets Grow." Shared.

KRMD

1310 kc, Shreveport, La., Robert M. Dean, 50 w. shared, C.

KRSC

1120 kc, Seattle, Wash., Radio Sales Corp., 50 w daytime, P.

KSAC

580 kc, Manhattan, Kan., Kansas State Agricultural College, 500 w. C. Shared.

KSBA

1450 kc, Shreveport, La., W. G. Patterson, 1000 w, C, "Keep Shreveport Before America."

KSCJ

1330 kc, Sioux City, Iowa, Perkins Bros. Co., 1000 w. C. Shared.

KSD

550 kc, St. Louis, Mo., Pulitzer Pub. Co., 500 w, C. Shared.

KSEI

900 kc, Pocatello, Idaho, KSEI Broadcasting Assn., 250 w, M, "Kummunity Southeast Idaho."

KSL

1130 kc, Salt Lake City, Utah, Radio Service Corp., 5000 w, M, "The Voice of the Intermountain Empire."

KSMR

1200 kc, Santa Maria, Calif., Santa Maria Valley R. R. Co., 100 w, P, "The Valley of Gardens."

KSO

1380 kc, Clarinda, Iowa, Berry Seed Co., 1000 w, C, "Keep Serving Others."

KSOO

1110 kc, Sioux Falls, S. D., Sioux Falls Broadcasting Assn., 1000 w daytime, C.

KSTP

1460 kc, Westcott, Minn., National Battery Broadcasting Co., 10,000 w, C.

KTAB

550 kc, Oakland, Calif., Associated Broadcasters, 500 w. P, "Knowledge, Truth and Beauty." Shared.

KTAP

1420 kc, San Antonio, Texas, Robert B. Bridge, 100 w, C, "The World's Biggest Little Station."

KTAT

1240 kc, Ft. Worth, Texas, Texas Air Transport Broadcasting Co., 1000 w, C. Shared.

KTBI

1300 kc, Los Angeles, Calif., Bible Institute of Los Angeles, 750 w, P. Shared.

KTBR

1300 kc, Portland, Ore., M. E. Brown, 500 w, P. Shared.

KTHS

800 kc, Hot Springs, Ark., Chamber of Commerce, 10,000 w, C, "Kum to Hot Springs." Shared.

KTM

780 kc, Santa Monica, Calif., Pickwick Broadcasting Corp., 500 w, P, "The Station with a Smile." Shared.

KTNT

1170 kc, Muscatine, Iowa, Norman Baker, 5000 w, C, "The Voice of the Iowa Farmers' Union." Shared.

KTSA

1290 kc, San Antonio, Texas, Lone Star Broadcast Co., 1000 w, C. Shared.

KTUE

1420 kc, Houston, Texas, Uhalt Electric, 5 w, C.

KTW

1270 kc, Seattle, Wash., First Presbyterian Church, 1000 w, P. Shared.

KUJ

1500 kc, Longview, Wash., F. W. Lovejoy & R. W. Kerfoot, 10 w, P. Shared.

KUOA

1390 kc, Fayetteville, Ark., University of Arkansas, 1000 w. C. Shared.

KUOM

570 kc, Missoula, Mont., State University of Montana, 500 w, M.

KUSD

890 kc, Vermilion, S. Dak., University of South Dakota, 500 w, C. Shared.

KUT

1120 kc, Austin, Texas, University of Texas, 500 w, C, "Come to University of Texas." Shared.

KVI

1340 kc, Tacoma, Wash., Puget Sound Radio Broadcasting Co., 1000 w, P, "Puget Sound Station." Shared.

KVL

1370 kc, Seattle, Wash., Arthur C. Bailey, 100 w. Shared.

KVOO

1140 kc, Tulsa, Okla., Southwestern Sales Corp., 5000 w, C, "The Voice of Oklahoma." Shared.

KVOS

1200 kc, Bellingham, Wash., L. Kessler, 100 w, M. Shared.

KWBS

1500 kc, Portland, Ore., Schaeffer Radio Co., 15 w, P.

KWCR

1310 kc, Cedar Rapids, Iowa, Harry F. Paar, 100 w. Shared.

KWEA

1210 kc, Shreveport, La., William E. Antony, 100 w, C.

KWG

1200 kc, Stockton, Calif., Portable Wireless Tel. Co., 100 w, P. Shared.

KWJJ

1060 kc, Portland, Ore., Wilbur Jerman, 500 w, P. "The Voice from Broadway."

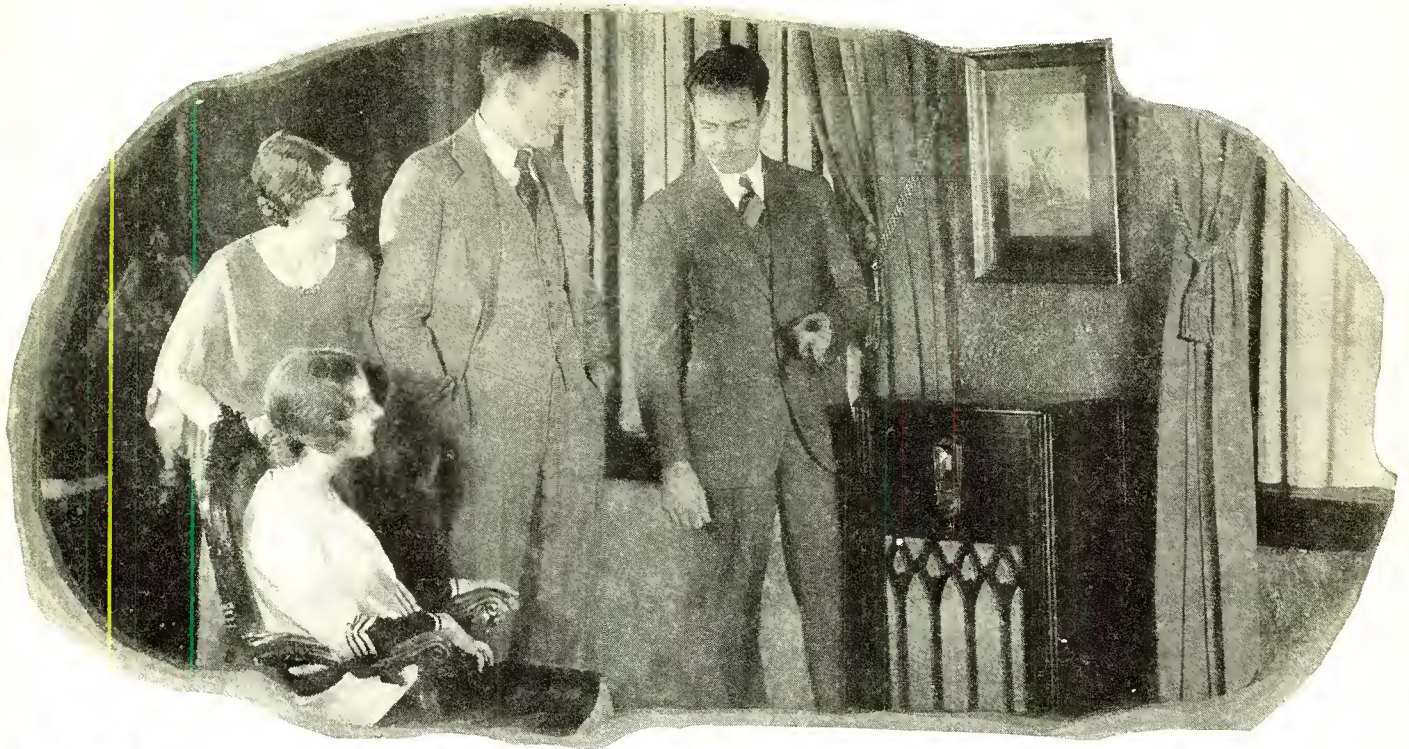

They Could Hardly Believe Their Own Ears - when I Switched to Ground Wave Reception!

"It's no use trying to listen in tonight," said Bill as I took his hat. "Jane and I tried to get reception during dinner but all we got was static. It's usually this way—just the night they broadcast Paul Whitman's band or some other good program it's spoiled by howls and fading. Why own a radio at all?" he ended up disgustingly.

"Perhaps my set will do a little better," I suggested. I had a surprise in store for him!

He looked doubtful as I turned on the set switch. I had left my old aerial antenna attached on purpose and soon the room was filled with an ear-splitting excuse for music. Manipulation of the dials only served to make it worse or to choke down reception until it was hardly audible. Occasionally it faded out altogether and I could picture the roof aerial swaying helplessly in the strong wind. Then the jumble and howls would start up again until my wife finally shouted above the din, "Turn that thing off—it's terrible."

Satisfied, I laughed and disconnecting the old aerial and ground wires, I then attached the lead-in wires of my new underground antenna, which I had installed just before dinner. "Now listen!" I commanded.

THE THRILLING TEST

As though by magic, the sweet high notes of violins, the s'rring sobbing of saxophones, the clear pure notes of a

clarinet brought Bill to his feet! Jane looked dumbfounded. Even my wife, who had not paid much attention to my preliminary tests, was amazed. "What did you do to it?" she demanded. "I think he bewitched it," Jane accused. The music went on, clear and strong, with only a long moan or slight jumble now and then to remind us of the storm raging outside. The static was so greatly reduced that we hardly noticed it. The important thing was—we were getting one of the year's best programs with scarcely any trouble on a wild, stormy night.

"You see," I explained later to Bill, "I buried my new underground aerial about two feet below the ground, where wind and storms can't affect it so easily. It has certainly been proved

dress of the Subwave-Aerial manufacturer in his pocket.

TEST IT YOURSELF—FREE!

The above story illustrates the results for which the designers of Subwave Aerial struggled for months. At last, enthusiastic reports such as this from Radio Experts reproduced here, proved that they had succeeded. Now you have a chance to prove the merits of this great new radio development for yourself. Try, if possible, to pick a night when static is bad and make the thrilling test. It's fun! And if you are not more than pleased with Subwave-Aerial, the test won't cost you a cent. We feel safe in saying, however, that once you've heard the amazing difference in reception and realize the wonderful convenience of this modern combined antenna and ground, you'll wonder how you ever put up with the old-fashioned, dangerous, inefficient methods. Be sure to send at once for all the interesting details on the development of Subwave-Aerial. It's the newest, most thrilling thing in the romantic world of radio! Use the coupon below. Fill it in and mail it NOW!



UNDERGROUND AERIAL PRODUCTS,
 Suite 618, St. Clair Building, Dept. 502-C.W.
 St. Clair & Erie Sts., Chicago, Ill.

Underground Aerial Products
 Suite 618, St. Clair Bldg.
 Dept. 502-C.W., St. Clair and Erie St., Chicago, Ill.
 Rush illustrated literature on the new Subwave-Aerial and details of your Free Test Offer.

Name.....
 Address.....
 City..... State.....

Subwave-Aerial Gets DX Installed 50 Feet from 60,000 Volt Power Line.

Gentlemen:
 On January 27, 1929, Mr. Frank Smith and I drove out near the Sanitary District power plant in a Ford Sedan. We stopped 50 feet from the plant's 60,000 volt transmission line and dug a small hole, into which we dropped the Subwave-Aerial. We left the two sets we brought with us in the sedan, attaching the lead-in wires of the Subwave-Aerial first to one, then the other, a 5-tube Freshman and a single dial Atwater Kent, Model 35. We used the Ford battery.

At 15 minutes to six we got W-C-O, St. Paul, Minn. It came in loud and clear at 27 on the dial. There was not the slightest interference from the 60,000 volt power transmission line. We got Toronto, Can., first on one set and then the other. It was impossible to get reception at all with an overhead aerial under the same conditions.

Yours truly,
 Harry R. Jackson,
 F. Bennett Smith.

Hardly necessary to say that Bill went home with the name and ad-

- KWK**
1350 kc, St. Louis, Mo., Greater St. Louis Broadcasting Corp., 1000 w, C.
- KWKC**
1370 kc, Kansas City, Mo., Wilson Duncan Broadcasting Co., 100 w.
- KWKH**
850 kc, Kennonwood, La., W. K. Henderson, 20,000 w, C. Shared.
- KWLC**
1270 kc, Decorah, Iowa, Luther College, 100 w, C. Shared.
- KWSC**
1390 kc, Pullman, Wash., State College of Washington, 500 w, P, "The Voice of the Cougars." Shared.
- KWTC**
1500 kc, Santa Ana, Calif., Pacific Broadcasting Fed., 100 w, P, "Kum West to California." Shared.
- KWWG**
1260 kc, Brownsville, Texas, Chamber of Commerce, 500 w, C, "Good Night, World." Shared.
- KXA**
570 kc, Seattle, Wash., American Radio Tel. Co., 500 w, P. Shared.
- KXL**
1250 kc, Portland, Ore., KXL Broadcasters, Inc., 500 w, P, "The Voice of Portland." Shared.
- KXO**
1200 kc, El Centro, Calif., Irey & Bowles, 100 w, P.
- KXRO**
1420 kc, Aberdeen, Wash., KXRO, Inc., 75 w.
- KYA**
1230 kc, San Francisco, Calif., Pacific Broadcasting Corp., 1000 w, P.
- KYW**
1020 kc, Chicago, Ill., Westinghouse E. & M. Co., 5000 w, C.
- KYWA**
1020 kc, Chicago, Ill., Westinghouse Elec. & Mfg. Co., 500 w, C. Shared.
- KYWO**
600 kc, Laramie, Wyo., Bishop N. S. Thomas, 500 w, M, "The Top of the World."
- KZM**
1370 kc, Hayward, Calif., Leon P. Tenney, 100 w, P. Shared.
- NAA**
690 kc, 434.5 m, United States Navy Department, Washington, D. C., 1000 w, "Where the Time Signals Originate," E.
- WAAD**
1420 kc, Cincinnati, Ohio, Ohio Mechanic Institute, 25 w, E.
- WAAF**
920 kc, Chicago, Ill., Drivers Journal Pub. Co., 500 w daytime, C.
- WAAM**
1250 kc, Newark, N. J., WAAM, Inc., 500 w, E, "Sunshine Station."
- WAAT**
1070 kc, Jersey City, N. J., Bremer Broadcasting Corp., 300 w, Shared.
- WAAW**
660 kc, Omaha, Neb., Omaha Grain Exchange, 500 w daytime, C, "Pioneer Market Station of the West."
- WABC**
860 kc, New York City, N. Y., Atlantic Broadcasting Corp., 5000 w, E.
- WABI**
1200 kc, Bangor, Maine, First Universalist Church, 100 w, E, "The Pine Tree Wave."
- WABO**
See under WHEC.
- WABZ**
1200 kc, New Orleans, La., Coliseum Place Baptist Church, 100 w, C.
- WADC**
1320 kc, Akron, Ohio, Allen T. Simmons, 1000 w, E, shared, "Watch Akron Develop Commercially."
- WAFD**
1500 kc, Detroit, Mich., Albert B. Parfet Co., 100 w, E.
- WAGM**
1310 kc, Royal Oak, Mich., Robert L. Miller, 50 w, E.
- WAIU**
640 kc, Columbus, Ohio, American Insurance Union, 500 w, E, shared, "The Radio Voice of the American Insurance Union."
- WALK**
1500 kc, Willow Grove, Pa., Albert A. Walker, 50 w, E.
- WAPI**
1140 kc, Birmingham, Ala., Alabama Polytechnic Institute, 5000 w, C. Shared.
- WASH**
1270 kc, Grand Rapids, Mich., Baxter Laundries, Inc., 250 w, C. Shared.
- WBAA**
1400 kc, Lafayette, Ind., Purdue University, 500 w, C. Shared.
- WBAK**
1430 kc, Harrisburg, Pa., Pennsylvania State Police, 500 w, daytime, E, shared, "The Voice of Pennsylvania."
- WBAL**
1060 kc, Baltimore, Md., Consolidated Gas, Elec. Co., 10,000 w, E, shared, "The Station of Good Music."
- WBAP**
800 kc, Ft. Worth, Tex., Carter Publications, Inc., 50,000 w, C. Shared.
- WBAW**
1490 kc, Nashville, Tenn., Waldrum Drug Co., 5000 w, C. Shared.
- WBAX**
1210 kc, Wilkes-Barre, Pa., John H. Stenger, Jr., 100 w, E, "In Wyoming Valley, Home of the Anthracite."
- WBBC**
1400 kc, Brooklyn, N. Y., Brooklyn Broadcasting Corp., 500 w, Shared.
- WBBL**
1370 kc, Richmond, Va., Grace Covenant Presbyterian Church, 100 w, E, "Richmond, the Gateway North and South."
- WBBM**
770 kc, Chicago, Ill., Atlas Investment Co., 25,000 w, C.
- WBBR**
1300 kc, Rossville, N. Y., People's Pulpit Association, 1000 w, E, shared, "Watch Tower."
- WBBY**
1200 kc, Charleston, S. C., Washington Light Infantry, 75 w, E, "The Seaport of the Southeast."
- WBBZ**
1200 kc, Ponca City, Okla., C. L. Carrell, 100 w, C.
- WBCN**
See under WENR.
- WBCM**
1410 kc, Bay City, Mich., James E. Davidson, 500 w, E, "Where the Summer Trail Begins."
- WBET**
1360 kc, Medford, Mass., Boston Transcript Co., 500 w, E. Shared.
- WBIS**
See under WNAC.
- WBMS**
1450 kc, Fort Lee, N. J., WBMS Broadcasting Corp., 250 w, Shared.
- WBNY**
1350 kc, New York, N. Y., Baruchrome Corp., 250 w, E, shared, "The Voice of the Heart of New York."
- WBOQ**
See under WABC.
- WBOW**
1310 kc, Terre Haute, Ind., Banks of Wabash Broadcasting Assn., 100 w, C, "On the Banks of the Wabash."
- WBRC**
930 kc, Birmingham, Ala., Birmingham Broadcasting Co., 500 w, C, "The Biggest Little Station in the World."
- WBRE**
1310 kc, Wilkes-Barre, Pa., Louis G. Baltimore, 100 w, E.
- WBRL**
1430 kc, Tilton, N. H., Booth Radio Laboratories, 500 w, E. Shared.
- WBSO**
780 kc, Wellesley Hills, Mass., Babson's Statistical Org., Inc., 250 w, daytime, E.
- WBT**
1080 kc, Charlotte, N. C., C. C. Coddington, 5000 w, E, shared, "The Queen City of the South."
- WBZ**
990 kc, East Springfield, Mass., Westinghouse E. & M. Co., 15,000 w, E, shared, "The Broadcasting Station of New England."

An Entirely New Speaker!

THE 1929 MUTER ULTRADYNAMIC

Radio has reached its present state of perfection by a series of improvements in mechanical and theoretical design of parts, accessories and circuits. The most recent of these has been the Dynamic speaker.

Now *MUTER* presents an *improved* Dynamic Speaker, one that embodies all the desirable features of the Dynamic type—without its drawbacks.

The 1929 *MUTER* Dynamic has—

No Hum

When connected to a set and operating, there is no perceptible line or surface noise whatever. A weak or distant signal can be received clear and distinct. The "live" noise of the ordinary Dynamic is entirely eliminated.

This is accomplished by the use of an *improved filter circuit with tube rectifier*, giving an alternating current suppression equal to that of the "B" supply in the radio set. This also has the advantage of allowing an instant interchange of rectifiers, which is impossible with speakers using the customary dry rectifier.

No Drumming Emphasis of Low Notes

The 1929 *MUTER* Dynamic is so designed that it neither loses nor over-emphasizes any part of the musical scale. It is equally as faithful in the higher notes as in the lower and has no objectional hollow drumming sound on low notes.

Tonal frequency charts show that its response is superior over a frequency range 50% wider than any other Dynamic.

Superior Mechanical Design and Construction

The 1929 *MUTER* Dynamic has been designed by a foremost group of acoustical and speaker engineers. The quality of material and workmanship has seldom been approached in the construction of a radio accessory. Every vital part is matched to the general assembly. The cone, magnet and field coil are built and tested as a single unit by a method that instantly detects any variation whatsoever. Every 1929 *MUTER* Dynamic is a *perfect* speaker.

See and hear this new Dynamic Speaker at your dealer before equipping your new set or replacing your old speaker. Its superiority is instantly recognizable.

If your dealer cannot supply you, send us his name and address, and purchase price, and we will ship direct, express prepaid.

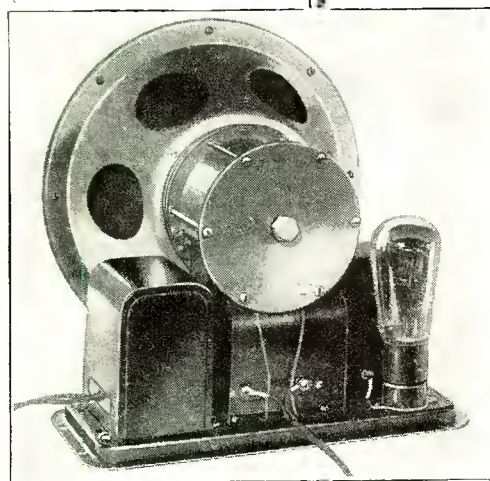

1929 MUTER
Dynamic Speaker
Type No. 4310
(110 v. A.C.)
List Price \$37.50

Special Notice

Complete Booklet on Dynamic Service and Installation Will Be Forwarded On Request

Without Charge

1 1 1

Every Dealer and Fan
Should Have This

Exclusive New Features of the 1929 MUTER Dynamic

Tube Rectifier . . . No Hum . . . No Surface Noise . . . Sensitivity to Weak or Distant Signals . . . Perfect Voice Reproduction . . . Matched Assembly and Testing . . . Lowest Current Consumption . . . Faithful Response Over 50% Wider Tonal Range . . . Adaptable to Any Set Instantly . . . Excellent for Phonograph Pick-Up . . . Unlimited Capacity for Undistorted Volume . . . Unqualified Guarantee by the Largest Manufacturer of Radio Accessories in the World.

LESLIE F. MUTER COMPANY

8440 South Chicago Avenue 1 1 1 Chicago

WBZA

990 kc, Boston, Mass., Westinghouse E. & M. Co., 500 w, E. Shared.

WCAC

600 kc, Storrs, Conn., Connecticut Agricultural College, 250 w, E. shared, "Voice From the Natmeg State."

WCAD

1220 kc, Canton, N. Y., St. Lawrence University, 500 w, daytime, E, "The Voice of the North Country."

WCAE

1220 kc, Pittsburgh, Pa., Kaufman & Baer Co., 500 w, E, "Where Prosperity Begins."

WCAH

1430 kc, Columbus, Ohio, Commercial Radio Service Co., 250 w, E. Shared.

WCAJ

590 kc, Lincoln, Neb., Nebraska Wesleyan University, 500 w, C. Shared.

WCAL

1250 kc, Northfield, Minn., St. Olaf College, 1000 w, C, shared, "The College on the Hill."

WCAM

1280 kc, Camden, N. J., City of Camden, 500 w, E. Shared.

WCAO

600 kc, Baltimore, Md., Monumental Radio, Inc., 250 w, E, "The Gateway of the South."

WCAP

1280 kc, Asbury Park, N. J., Radio Industries Broadcast Co., 500 w, E. Shared.

WCAT

1200 kc, Rapid City, S. D., South Dakota State School of Mines, 100 w, M.

WCAU

1170 kc, Philadelphia, Pa., Universal Broadcasting Co., 5000 w, E, "Where Cheer Awaits U."

WCAX

1200 kc, Burlington, Vt., University of Vermont, 100 w, E, shared, "The Voice of the Green Mountains."

WCAZ

1070 kc, Carthage, Ill., Carthage College, 100 w, daytime.

WCBA

1440 kc, Alentown, Pa., B. B. Musselman, 250 w, E. Shared.

WCBD

1080 kc, Zion, Ill., Wilbur Glen Voliva, 5000 w, C. Shared.

WCBM

1370 kc, Baltimore, Md., Baltimore Broadcasting Corp., 100 w, E.

WCBS

1210 kc, Springfield, Ill., Dewing & Meester, 100 w,

WCCO

810 kc, Anoka, Minn., Washburn-Crosby Co., 15,000 w, C, "Service to the Northwest."

WCDA

1350 kc, Cliffside Park, N. J., Italian Educational Broadcasting Co., 250 w, E. Shared.

WCFL

970 kc, Chicago, Ill., Chicago Federation of Labor, 1500 w, C, shared, "The Voice of Labor."

WCGU

1400 kc, Coney Island, N. Y., U. S. Broadcasting Corp., 500 w, E. Shared.

WCLB

1500 kc, Long Beach, Long Island, N. Y., Arthur Faske, 100 w, E, shared, "The Voice of Community Service."

WCLO

1200 kc, Kenosha, Wis., C. Whitmore, 100 w, C. Shared.

WCLS

1310 kc, Joliet, Ill., WCLS, Inc., 100 w, C. Shared.

WCMA

1400 kc, Culver, Ind., Culver Military Academy, 500 w, C, shared, "The Voice of Culver."

WCOA

1120 kc, Pensacola, Fla., City of Pensacola, 500 w, E, "Wonderful City of Advantages."

WCOC

880 kc, Columbus, Miss., Crystal Oil Co., 500 w, C.

WCOH

1210 kc, Greenville, N. Y., Westchester Broadcasting Corp., 100 w, E. Shared.

WCRW

1210 kc, Chicago, Ill., Clinton R. White, 100 w, C. Shared.

WCSH

940 kc, Portland, Me., Congress Square Hotel Co., 500 w, E, "The Voice From Sunrise Land."

WCSO

1380 kc, Springfield, Ohio, Wittenberg College, 500 w, E. Shared.

WCX

See under WJR.

WDAE

620 kc, Tampa, Fla., Tampa Publishing Co., 1000 w, E, "WDAE, the Voice of the Times at Tampa."

WDAF

610 kc, Kansas City, Mo., Kansas City Star Co., 1000 w, C, shared, "Enemies of Sleep."

WDAG

1410 kc, Amarillo, Texas, J. Lawrence Martin, 250 w, C, shared, "Where Dollars Always Grow."

WDAH

1310 kc, El Paso, Texas, Trinity Methodist Church, 100 w, M.

WDAY

1280 kc, Fargo, N. D., WDAY, Inc., 1000 w, C. Shared.

WDBJ

930 kc, Roanoke, Va., Richardson-Wayland Elec. Corp., 250 w, E, shared, "The Magic City."

WDBO

620 kc, Orlando, Fla., Rollins College, Inc., 1000 w, E, shared, "Down Where the Oranges Grow."

WDEL

1120 kc, Wilmington, Del., WDEL, Inc., 250 w, E, shared, "First City of the First State."

WDGY

1390 kc, Minneapolis, Minn., Dr. Geo. W. Young, 500 w, C. Shared.

WDOD

1280 kc, Chattanooga, Tenn., Chattanooga Radio Co., Inc., 500 w, C.

WDRC

1330 kc, New Haven, Conn., Doolittle Radio Corp., 500 w, E.

WDSU

1270 kc, New Orleans, La., Jos. H. Uhalt, 1000 w, C.

WDFW

1210 kc, Cranston, R. I., Duttee W. Flint, 100 w, E. Shared.

WDZ

1070 kc, Tuscola, Ill., James L. Bush, 100 w, daytime. Shared.

WEAF

660 kc, Bellmore, N. Y., National Broadcasting Co., Inc., 50,000, w, E.

WEAI

1270 kc, Ithaca, N. Y., Cornell Univ., 500 w, E.

WEAN

550 kc, Providence, R. I., The Shepard Co., 250 w, E, "We Entertain a Nation."

WEAO

550 kc, Columbus, Ohio, Ohio State University, 750 w, E. Shared.

WEAR

1070 kc, Cleveland, Ohio, WTAM and WEAR, Inc., 1000 w, E. Shared.

WEBC

1280 kc, Superior, Wis., Head of The Lakes Broadcasting Co., 1000 w, C. Shared.

WEBE

1210 kc, Cambridge, Ohio, Roy W. Waller, 100 w, E.

WEBQ

1210 kc, Harrisburg, Ill., First Trust & Savings Bank, 50 w, C. Shared.

WEBR

1310 kc, Buffalo, N. Y., H. H. Howell, 100 w, E, "We Extend Buffalo's Regards."

WEBW

600 kc, Beloit, Wis., Beloit College, 350 w, C, daytime.

WEDC

1210 kc, Chicago, Ill., Emil Denmark, Inc., 100 w, Shared.

WEDH

1420 kc, Erie, Pa., Erie Dispatch-Herald, 30 w, E.



**5000 Hours
Instead of 1000!**

When your fragile 1000 hour rectifier tube in your "B" Eliminator "blows", don't put another just like it in the socket—be modern—get one of the husky, solid, all dry 5000 hour Elkon EBH rectifiers from your dealer and forget your rectifying troubles for 5000 hours, at least.

The new Elkon EBH replaces all BH type rectifiers—no changes in wiring—simply take out the trouble-causing gas tube and plug in the smooth, powerful, trouble-free Elkon—that's all there is to it.

Other Elkon Replacement Rectifiers, too

Ask your dealer about the new dry Elkon rectifier which replaces the wet jar Philcatron type A and type AA in all Philco power units—trickle chargers, "A" Eliminator and A combinations. For the Philco "A" Eliminator equipped with Elkon rectifiers, use the Elkon M-16 for replacement. Eleven "A" Eliminator have used the M-16—be sure you get the M-16 in the red, black and yellow box.

The Elkon V-4 is used for 6 makes of trickle chargers, and the Elkon is the only authorized replacement rectifier for the Balkite Power Units, types N, K and J.

ELKON, INC.

Division of P. R. Mallory & Co.
350 Madison Ave., New York

ELKON, Inc., Dept. E-4
350 Madison Avenue, New York City

Kindly send me complete information on Elkon Radio Products.

Name _____ Address _____



Elkon rectifiers are tested with receiving sets

Tell 'Em You Saw It in the Citizens Radio Call Book Magazine and Scientific Digest

WEEI

590 kc, Boston, Mass., Edison Elec. Illum. Co., 500 w, E, "The Friendly Voice."

WEHS

1310 kc, Evanston, Ill., Victor C. Carlson, 100 w, C. Shared.

WELK

1370 kc, Philadelphia, Pa., Howard R. Miller, 100, E.

WEMC

590 kc, Berrien Springs, Mich., Emmanuel Missionary College, 1000 w, C, "The Radio Light-house."

WENR

870 kc, Chicago, Ill., Great Lakes Radio Broadcasting Co., 50,000 w, shared, C, "Voice of Service."

WEPS

1200 kc, Gloucester, Mass., Matheson Radio Co., Inc., 100 w, E. Shared.

WEVD

1300 kc, Woodhaven, N. Y., Debs Memorial Radio Fund, 500 w, E. Shared.

WEW

760 kc, St. Louis, Mo., St. Louis University, 1000 w, daytime, C.

WFAA

1040 kc, Dallas, Texas, Dallas Morning News, 50,000 w, C, "Working for All Alike." Shared.

WFAN

610 kc, Philadelphia, Pa., Keystone Broadcasting Co., Inc., 500 w, E.

WFBC

1200 kc, Knoxville, Tenn., First Baptist Church, 50 w, E.

WFBE

1200 kc, Cincinnati, Ohio, Park View Hotel, 100 w, E.

WFBG

1310 kc, Altoona, Pa., William F. Gable Co., 100 w, E, "The Original Gateway to the West and We Wish You All the Very Best."

WFBJ

1370 kc, Collegeville, Minn., St. Johns University, 100 w, C, "In the Heart of the Landscape Paradise."

WFBL

900 kc, Syracuse, N. Y., The Onondaga Co., Inc., 750 w, E, "When Feeling Blue, Listen." Shared.

WFBM

1230 kc, Indianapolis, Ind., Indianapolis Power & Light Co., 1,000 w, C. Shared.

WFBR

1270 kc, Baltimore, Md., Baltimore Radio Show, Inc., 250 w, E, "Home of the Star Spangled Banner."

WFDF

1310 kc, Flint, Mich., Frank D. Fallain, 100 w, E.

WFI

560 kc, Philadelphia, Pa., Strawbridge & Clothier, 500 w, E. Shared.

WFIW

940 kc, Hopkinsville, Ky., The Acme Mills, Inc., 1000 w, C.

WFJC

1450 kc, Akron, Ohio, W. F. Jones Broadcasting, Inc., 500 w, E. Shared.

WFKD

1310 kc, Frankford, Pa., Foulkrod Radio Eng. Co., 50 w, E.

WFLA

900 kc, Clearwater, Fla., Clearwater Chamber of Commerce and St. Petersburg Chamber of Commerce, 1000 w, E, "Inviting the World to the Springtime City." Shared.

WGAL

1310 kc, Lancaster, Pa., Lancaster Elec. Sup. & Const. Co., 15 w, E, "World's Gardens at Lancaster."

WGBB

1210 kc, Freeport, N. Y., Harry H. Carman, 100 w, E, "The Voice of the Sunrise Trail." Shared.

WGBC

1430 kc, Memphis, Tenn., First Baptist Church, 500 w, C. Shared (Sunday only).

WGBF

630 kc, Evansville, Ind., Evansville on Air, 500 w, E, "Gateway to the South."

WGBI

880 kc, Scranton, Pa., Scranton Broadcasters, Inc., 250 w, E. Shared.

WGBS

1180 kc, Astoria, L. I., N. Y., General Broadcasting System, Inc., 500 w, E.

WGCM

1210 kc, Gulfport, Miss., Gulf Coast Music Co., Inc., 100 w, C.

WGCP

1250 kc, Newark, N. J., May Radio Broadcast Corp., 250 w. Shared.

WGES

1360 kc, Chicago, Ill., Oak Leaves Broadcasting Corp., 500 w, C, "World's Greatest Entertainment Service." Shared.

WGH

1310 kc, Newport News, Va., Virginia Broadcasting Co., Inc., 100 w, E.

WGHP

1240 kc, Fraser, Mich., American Broadcasting Corp., Inc., 750 w, E.

WGL

1370 kc, Ft. Wayne, Ind., Allen-Wayne Co., 100 w, C, daytime. Shared.

WGMS

See under WLB.

WGN

720 kc, Chicago, Ill., Tribune Co., 25,000 w, C.

WGR

550 kc, Buffalo, N. Y., WGR, Inc., 1000 w, E, "Key City of Industry." Shared.

WGST

890 kc, Atlanta, Ga., Georgia School of Technology, 250 w, E, "The Southern School with the National Reputation." Shared.

WGY

790 kc, South Schenectady, N. Y., General Electric Co., 50,000 w, E.

WHA

570 kc, Madison, Wis., University of Wisconsin, 750 w, C. Shared.

WHAD

1120 kc, Milwaukee, Wis., Marquette University, 250 w, C. Shared.

WHAM

1150 kc, Rochester, N. Y., Stromberg-Carlson Tel. Mfg. Co., 5000 w, E.

WHAP

1300 kc, New York, N. Y., Defenders of Truth Society, Inc., 1000 w, E. Shared.

WHAS

820 kc, Louisville, Ky., The Courier Journal Co. & Louisville Times Co., 5000 w, C.

WHAZ

1300 kc, Troy, N. Y., Rensselaer Polytechnic Institute, 500 w, E. Shared.

WHB

950 kc, Kansas City, Mo., Sweeney Automobile School Co., 500 w, C, "Kansas City, Mo., the Heart of America." Shared.

WHBC

1200 kc, Canton, Ohio, St. John's Catholic Church, 10 w, E.

WHBD

1370 kc, Bellefontaine, Ohio, First Presbyterian Church, 100 w, E, "Ohio's Highest Point."

WHBF

1210 kc, Rock Island, Ill., Beardsley Specialty Co., 100 w, C.

WHBL

1410 kc, Sheboygan, Wis., Press Pub. Co., 500 w, C. Shared.

WHBP

1310 kc, Johnstown, Pa., Johnstown Automobile Co., 100 w, E, "The Voice of the Friendly City."

WHBQ

1370 kc, Memphis, Tenn., Broadcasting Station WHBQ, Inc., 100 w, C.

WHBU

1210 kc, Anderson, Ind., Citizens Bank, 100 w, C, "First Hoosier Bank on the Air."

WHBW

1500 kc, Philadelphia, Pa., D. R. Kienzle, 100 w, E.

WHBY

1200 kc, West De Pere, Wis., St. Norbert's College, 100 w, C.

WHDF

1370 kc, Calumet, Mich., C. C. MacLeod, 100 w, C.

Unquestionably~ the Most Complete Radio Testing Apparatus Ever Devised

THE SUPREME is sweeping the country by storm. Radiotricians and engineers everywhere are amazed at its performance, and its already long list of users are enthusiastically proclaiming its superiority. Truly an amazing instrument; it makes every test that can be made by all other testing devices combined and many that heretofore have not been available in any service instrument.

Complete, Handy Carrying Case

The case containing the instrument was designed after careful study by practical radiotricians of many years' experience in radio service. Its arrangement is most complete and convenient—a proper place for every tool, accessory, part and material that a service man might need; even a swinging tube shelf that affords absolute protection to tubes. A complete set of tools, from electric soldering iron to screw driver, is furnished, and of course, all necessary adapters and accessories. Everything the service man requires—all in one case. And still due to ingenious design, this case is only 18x10½x7 in. and weighs complete only 25 pounds.

Send No Money

The SUPREME must sell itself to you on sheer merit and performance. We are willing to place it in your hands for actual use in your service work, and allow you to be the sole judge of its value. Fill out and sign the following request for six-day trial.

6 DAY TRIAL

Date.....

Supreme Instruments Corporation,
315 Supreme Building,
Greenwood, Miss.

Please ship me one Model 400A SUPREME.

Upon delivery of the instrument, I will deposit with the express agent either the cash price of \$124.65 or \$38.50 cash and 10 trade acceptances (installment notes) for \$10 each, due monthly, at my option, subject to the following conditions:

It is agreed that the deposit made with the express agent shall be retained by him for six days. If, within that time, after testing the instrument I am not entirely satisfied, I have the privilege of returning the instrument to the express agent in good condition, with the seal unbroken (see note below) and all tools and parts intact. Upon such return and upon the prepayment of return express charges, the deposit I have made with the express agent will be promptly returned to me.

Signed.....

Firm Name.....

Address.....

City.....State.....

Please send three or more trade references, including at least one bank, with this coupon.

NOTE: The seal on the panel of the instrument covers the master screw in the assembly. It is never necessary to disturb this, and it does not in any way prevent or restrict the use of the instrument. Factory guarantee ceases with disturbance of seal.

Three Weston Meters

Mounted in Bakelite cases.

1 Voltmeter, three scales of 0/10/100/600, 1000 ohms per volt.

1 Millammeter, of 125 mils and 2½ amps.

1 A.C. Voltmeter, three large scales of 0/3/15/50.

All instruments are manufactured for 110 volts and 60 cycles. Instruments for other voltages or frequencies can be furnished special at slight increase in price.

Prices and Terms

Under our time payment plan, the Model 400A SUPREME can be bought for \$38.50 cash and 10 trade acceptances (installment notes) for \$10 each, due monthly. Cash price, if preferred, \$124.65. All prices are net and do not carry dealers' discounts.

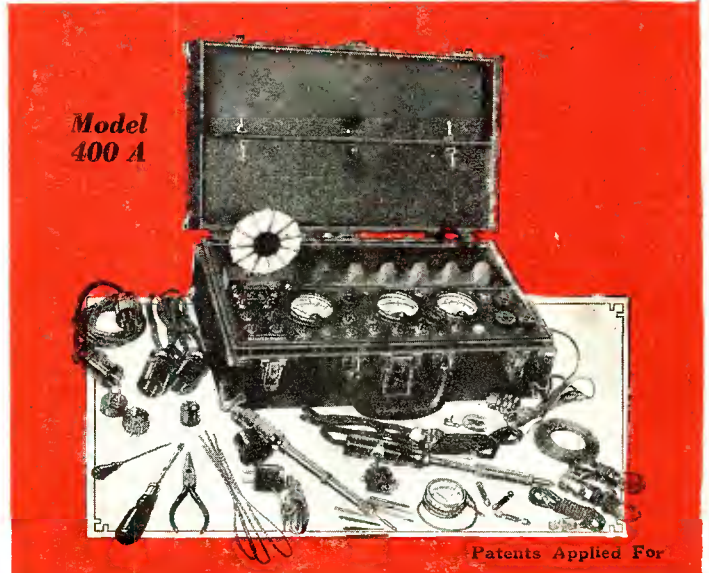

conceivable
Makes every test on any Radio Set-

You have waited long and patiently for an instrument such as the SUPREME. It is now here—at your command for greater accuracy and thoroughness, bigger profits and satisfied customers.

Tubes, power units, loads, breakdowns, voltages, all instantly analyzed, peaking condensers, also modulated radiator. Everything you have ever hoped for is there, all contained in one compact instrument.

The only self-rectifying oscillation tester in existence.

The exact working conditions of any tube from 1½ to 15 volts, including screen grid, heater type, and rectifier tubes, are shown by meter readings; the only service instrument that shows output of rectifier tubes on meter.

The oscillation tests from alternating current are made possible by the exclusive self-rectifying SUPREME Power Plant. Every radio engineer and service man will appreciate this feature.

The SUPREME radiator sends out a modulated wave. Simply plug into A.C. line. No more wasting valuable time on broadcast stations; always at your service and finer adjustment assured.

Condensers can be balanced or synchronized—not by the former tedious methods—but with both meter reading and audible click. Easy and much more accurate.

All continuity tests can be made from socket on either A.C. or D.C. sets, with independent cathode readings.

The SUPREME heavy duty rejuvenator provides scientific method of rejuvenation of any thoriated filament tube. Will reactivate up to 12 tubes at one time without removal from set. Push a plug—the SUPREME does the rest.

The SUPREME will give direct readings of amplifying power of tubes and will show actual working condition of all tubes.

The SUPREME will play radios with open trans-

formers and will give condenser, choke coil output, and capacity output on radios not wired for that purpose.

Access is provided to all apparatus through pin-jacks. Will test condensers for breakdown. Contains various fixed condensers from .001 to 2 mfd., a 30 ohm rheostat, a 500,000 ohm variable resistance, and an audio transformer, for instant use and various combinations.

It will give plate and filament voltage readings, with or without load; will test voltage and current of all radios, including those using tubes such as 210 and 250. It will give grid circuit readings up to 100 volts; plate voltage readings up to 600 volts; will test output of trickle chargers, or any output up to 2½ amps.

Why wait longer? Share in the satisfaction and added profits that come with SUPREME ownership.

The Sign of EFFICIENT RADIO SERVICE

Radio Owners: Look for this emblem in your radio shop or on the button worn or card carried by your service man. It is your guarantee of dependable service.



SUPREME Radio Diagnometer

Tell 'Em You Saw It in the Citizens Radio Call Book Magazine and Scientific Digest

WHDH

830 kc, Gloucester, Mass., Matheson Radio Co., Inc., 1000 w, E.

WHDI

1390 kc, Minneapolis, Minn., Wm. Hood Dunwoody Ind. Inst., 500 w, C. Shared.

WHDL

1420 kc, Tupper Lake, N. Y., George Franklin Bissell, 10 w, E.

WHEC

1440 kc, Rochester, N. Y., Hickson Electric Co., Inc., 500 w, E. Shared.

WHFC

1310 kc, Cicero, Ill., Goodson & Wilson, Inc, 100 w, C. Shared.

WHK

1390 kc, Cleveland, Ohio, Radio Air Service Corp., 1000 w, E, "Cleveland's Pioneer Station." Shared.

WHN

1010 kc, New York, N. Y., Marcus Loew Booking Review, 250 w, E, "Voice of the Great White Way." Shared.

WHO

1000 kc, Des Moines, Iowa, Bankers Life Co., 5000 w, C, "W-H-O, Who? Banker's Life, Des Moines." Shared.

WHPP

1420 kc, New York, N. Y., Bronx Broadcasting Co., 10 w, E. Shared.

WHT

1480 kc, Deerfield, Ill., Radiophone Broadcasting Corp., 5000 w, C. Shared.

WIAS

1420 kc, Ottumwa, Iowa, Poling Electric Co., 100 w, daytime, C. Shared.

WIBA

1210 kc, Madison, Wis., Capital Times-Strand Theater Station, 100 w, C.

WIBG

930 kc, Elkins Park, Pa., St. Paul's M. E. Church, 50 w, daytime, E.

WIBM

1370 kc, Jackson, Mich., C. L. Carrell, 10 w.

WIBO

570 kc, Desplains, Ill., Nelson Bros, Bond & Mortgage Co., 1000 w, C. Shared.

WIBR

1420 kc, Steubenville, Ohio, Thurman A. Owings, 50 w, E, "Where Investments Bring Results."

WIBS

1450 kc, Elizabeth, N. J., New Jersey Broadcasting Co., 250 w, E.

WIBU

1310 kc, Poyette, Wis., W. C. Forrest, 100 w, C.

WIBW

1300 kc, Topeka, Kan., Topeka Broadcasting Assn., Inc., 1000 w, C, "Topeka—Where Investment Brings Wealth." Shared.

WIBX

1200 kc, Utica, N. Y., WIBX, Inc., 100 w, E.

WIBZ

1500 kc, Montgomery, Ala., Alexander D. Trum, 15 w, C, "We Interest Business Zeal."

WICC

1190 kc, Easton, Conn., Bridgeport Broadcasting Station, Inc., 500 w, E, "The Industrial Capital of Connecticut." Shared.

WIL

1420 kc, St. Louis, Mo., Missouri Broadcasting Co., 100 w, C, "A Wave Length Ahead." Shared.

WILL

890 kc, Urbana, Ill., University of Illinois, 250 w, C. Shared.

WILM

1500 kc, Wilmington, Del., Delaware Broadcasting Co., Inc., 100 w, E.

WINR

1210 kc, Bayshore, N. Y., Radiotel Mfg. Co., 100 w, E, shared, "The Garden Spot of Long Island."

WIOD

1240 kc, Miami Beach, Fla., Isle of Dreams Broadcasting Co., 1000 w, E, "Wonderful Isle of Dreams." Shared.

WIP

610 kc, Philadelphia, Pa., Gimbel Bros., Inc., 500 w, E, "Watch Its Progress."

WISN

1120 kc, Milwaukee, Wis., Evening Wisconsin Co., 250 w, C.

WJAD

1240 kc, Waco, Texas, Frank P. Jackson, 1000 w, C, shared, "Waco, Texas, All Around It."

WJAG

1060 kc, Norfolk, Neb., Norfolk Daily News, 500 w, C, shared, "Home of the Printer's Devil."

WJAK

1310 kc, Kokomo, Ind., J. A. Kautz, 50 w. Shared.

WJAR

890 kc, Providence, R. I., The Outlet Co., 250 w, E, "The Southern Gateway of New England."

WJAS

1290 kc, Pittsburgh, Pa., Pittsburgh Radio Supply House, 1000 w, E.

WJAX

1260 kc, Jacksonville, Fla., City of Jacksonville. 1000 w, E, shared, "WJAX—W for Wonderful, JAX for Jacksonville."

WJAY

1450 kc, Cleveland, Ohio, Cleveland Radio Broadcasting Corp., 500 w, E. Shared.

WJAZ

1480 kc, Mt. Prospect, Ill., Zenith Radio Corp., 5000 w, C. Shared.

WJBC

1200 kc, LaSalle, Ill., Hummer Furniture Co., 100 w, C. Shared.

WJBI

1210 kc, Red Bank, N. J., Robt. S. Johnson, 100 w, E. Shared.

WJBK

1370 kc, Ypsilanti, Mich., Ernest F. Goodwin, 50 w, C.

WJBL

1200 kc, Decatur, Ill., Wm. Gushard Dry Goods Co., 100 w, C. Shared.

WJBO

1370 kc, New Orleans, La., Valdemar Jensen, 100 w, C.

WJBT

See under WBBM.

WJBU

1210 kc, Lewisburg, Pa., Bucknell University, 100 w, E, shared, "In the Heart of the Keystone State."

WJBW

1200 kc, New Orleans, La., C. Carlsen, Jr., 30 w, C, shared, "The Serve You Broadcasting Station at New Orleans."

WJBY

1210 kc, Gadsden, Ala., Electric Cons. Co., 50 w, C.

WJJD

1180 kc, Mooseheart, Ill., Loyal Order of Moose, 20,000 w, C, shared, "Every Child Is Entitled to a High School Education and a Trade." Shared.

WJKS

1360 kc, Gary, Ind., Johnson-Kennedy Radio Corp., 500 w, C. Shared.

WJR

750 kc, Detroit, Mich., WJR, Inc., 5000 w, E.

WJSV

1460 kc, Mt. Vernon Hills, Va., Independent Pub. Co., 10,000 w.

WJZ

760 kc, New York City, N. Y., Radio Corporation of America, 30,000 w, E.

WKAQ

890 kc, San Juan, Porto Rico, Radio Corp. of Porto Rico, 500 w, E, "Porto Rico, The Island of Enchantment in the Caribbean Sea."

WKAR

1040 kc, East Lansing, Mich., Michigan State College, 500 w, daytime, E.

WKAU

1310 kc, Laconia, N. H., Laconia Radio Club, 100 w, E, "The Voice of the Winnepesaukee Lake Region."

WKBB

1310 kc, Joliet, Ill., Sanders Bros., 100 k, C. Shared.

WKBC

1310 kc, Birmingham, Ala., R. B. Bryoles Furniture Co., 10 w, C.

WKBE

1200 kc, Webster, Mass., K. & B. Electric Co., 100 w, E. Shared.

WKBF

1400 kc, Indianapolis, Ind., Noble Butler Watson, 500 w, C, shared, "We Keep Building Friendships."

WKBH

1380 kc, LaCrosse, Wis., Callaway Music Co., 1000 w, C. Shared.

WKBI

1310 kc, Chicago, Ill., Fred L. Schoenwolf, 50 w, C. Shared.

WKBN

570 kc, Youngstown, Ohio, W. P. Williamson, Jr., 500 w, E. Shared.

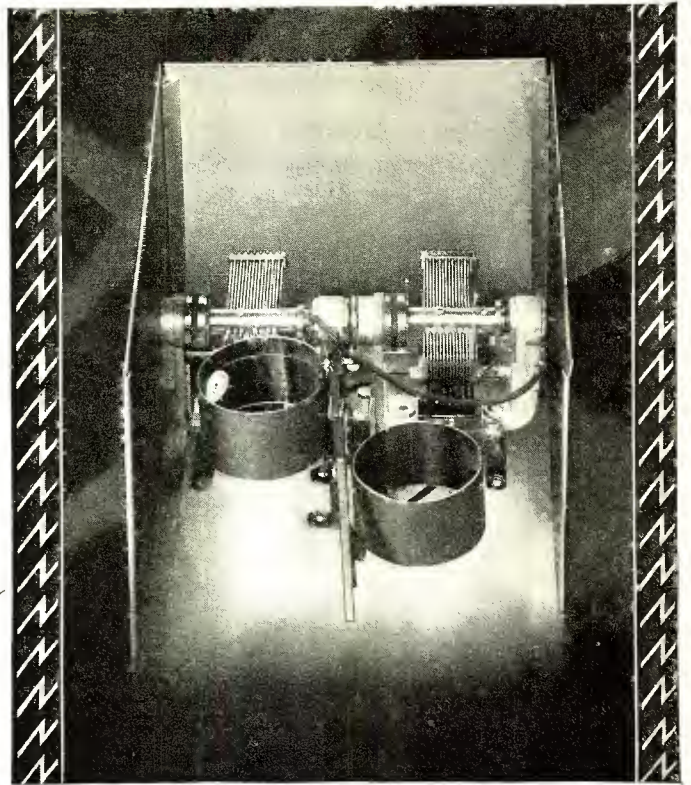

BAND PASS FILTER

THE Master Hi-Q 29 is the only circuit permitting the use of shield-grid tubes at their maximum amplifying ability.

So remarkable has been the performance of this receiver that not only are professional men everywhere building it, but the engineers of nearly a score of the foremost radio companies have purchased it either for personal use or for laboratory experiment.

Due to the characteristics of loosely tuned circuits, each of the doubly tuned radio-frequency transformers used in the Hi-Q '29 actually constitutes a "band-pass filter", the effect of which is shown in the graph below. Space does not permit full description of the many advantages thus gained but the informed radio man should quickly grasp the results

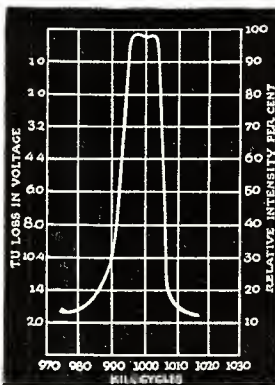

Effects
FLAT-TOP tuning
10 K.C. selectivity
PERFECT tone

shown in the exclusive Hi-Q "flat-top" response curve.

The sum total of Hi-Q '29 design is a finer degree of both sensitivity and selectivity than has ever been known before with the added advantages of tone quality which experts admit is nothing short of epoch-making.

It will pay you to write for our 80-page illustrated book on Hi-Q "Band-Pass Tuning" and construction details of the four Hi-Q models. Price is 25c. Use the coupon.

Hi-Q 29

HAMMARLUND-ROBERTS, Inc., 1182T Broadway, New York

Enclosed find 25c for my copy of your book on Hi-Q Band Pass Filter Circuits and full construction details on your four Hi-Q models.

NAME.....

ADDRESS.....

Tell 'Em You Saw It in the Citizens Radio Call Book Magazine and Scientific Digest

WKBO

1450 kc, Jersey City, N. J., Camith Corp., 250 w, E. Shared.

WKBP

1420 kc, Battle Creek, Mich., Enquirer-News Co., 50 w, E.

WKBQ

1350 kc, New York, N. Y., Standard Cahill Co., Inc., 250 w, E. Shared.

WKBS

1310 kc, Galesburg, Ill., Permil N. Nelson, 100 w, C. Shared.

WKBV

1500 kc, Brookville, Ind., Knox Battery & Electric Co., 100 w, C.

WKBW

1470 kc, Buffalo, N. Y., Churchill Evan. Assn., Inc., 5000 w, E, shared.

WKBZ

1500 kc, Ludington, Mich., K. L. Ashbacker, 50 w.

WKEN

1040 kc, Buffalo, N. Y., WKEN, Inc., 1000 w, E. Shared.

WKJC

1200 kc, Lancaster, Pa., Kirk Johnson & Co., 100 w, E.

WKRC

550 kc, Cincinnati, Ohio, Kodel Radio Corp., 500 w, E, "WKRC, K—Kodel, R—Radio, C—Corporation."

WKY

900 kc, Oklahoma City, Okla., WKY Radiophone Co., 1000 w, C.

WLAC

1490 kc, Nashville, Tenn., Life & Casualty Ins. Co., 5000 w, C, shared, "The Thrift Station."

WLAP

1200 kc, Louisville, Ky., American Broadcasting Corp. of Kentucky, 30 w, C.

WLB

1250 kc, Minneapolis, Minn., University of Minnesota, 500 w, C. Shared.

WLBC

1310 kc, Muncie, Ind., Donald A. Burton, 50 w, Shared.

WLBF

1420 kc, Kansas City, Mo., Everett L. Dillard, 100 w, C, "Where Listeners Become Friends."

WLBG

1200 kc, Petersburg, Va., Robert Allen Gamble, 100 w, E.

WLBH

1420 kc, Farmingdale, N. Y., Joseph J. Lombardi, 30 w, Shared.

WLBL

900 kc, Stevens Point, Wis., Wisconsin Department of Markets, 2000 w, daytime, C, "Wisconsin, Land of Beautiful Lakes."

WLBO

1310 kc, Galesburg, Ill., Fred Trebbe, Jr., 100 w, C. Shared.

WLBV

1210 kc, Mansfield, Ohio, Mansfield Broadcasting Association, 100 w, E.

WLBW

1260 kc, Oil City, Pa., Petroleum Telephone Co., 500 w, E.

WLBX

1500 kc, Long Island City, N. Y., John N. Braby, 100 w, E. Shared.

WLBZ

620 kc, Bangor, Me., Maine Broadcasting Co., 250 w, E.

WLCI

1210 kc, Ithaca, N. Y., Lutheran Assn. of Itaca, 50 w, E.

WLEX

1420 kc, Lexington, Mass., Lexington Air Station, 100 w, E. Shared.

WLIB

See under WGN.

WLIT

560 kc, Philadelphia, Pa., Lit Brothers, 500 w, E, shared, "The Quaker City Siren."

WLOE

1500 kc, Chelsea, Mass., Boston Broadcasting Co., 100 w, Shared.

WLS

870 kc, Crete, Ill., Agricultural Broadcasting Co., 5000 w, C, shared.

WLSI

See under WDFW.

WLTH

1400 kc, Brooklyn, N. Y., Voice of Brooklyn, Inc., 500 w, E. Shared.

WLW

700 kc, Mason, Ohio, Crosley Radio Corp., 25,000 w, E.

WLWL

1100 kc, New York, N. Y., Missionary Society of St. Paul, 5000 w, 6-8 pm, E. Shared.

WMAC

570 kc, Casenovia, N. Y., Clive B. Meredith, 250 w, E, shared, "Voice of Central New York."

WMAF

1360 kc, Dartmouth, Mass., Round Hills Radio Corp., 500 w, E. Shared.

WMAK

900 kc, Martinsville, N. Y., WMAK Broadcasting System, Inc., 750 w, E. Shared.

WMAL

630 kc, Washington, D. C., M. A. Leese Co., 250 w, E. Shared.

WMAN

1210 kc, Columbus, Ohio, W. E. Heskitt, 50 w, E.

WMAQ

670 kc, Chicago, Ill., Chicago Daily News, Inc., 5000 w, C.

WMAY

1200 kc, St. Louis, Mo., Kingshighway Presbyterian Church, 100 w.

WMAZ

890 kc, Macon, Ga., Mercer University, 250 w, E, shared, "Watch Mercer Attain Zenith." Shared.

WMBA

1500 kc, Newport, R. I., LeRoy Joseph Beebe, 100 w, E.

WMBC

1420 kc, Detroit, Mich., Michigan Broadcasting Co., Inc., 100 w, E.

WMBD

1440 kc, Peoria Heights, Ill., Peoria Heights Radio Laboratory, 500 w. Shared.

WMBF

560 kc, Miami Beach, Fla., Fleetwood Hotel Corp., 500 w, E, shared, "Wonderful Miami Beach Fleetwood."

WMBH

1420 kc, Joplin, Mo., Edwin Dudley Aber, 100 w, C, "Where Memories Bring Happiness."

WMBI

1080 kc, Chicago, Ill., Moody Bible Institute Radio Station, 5000 w, C, shared, "The West Point of Christian Service."

WMBG

1210 kc, Richmond, Va., Havens & Martin, Inc., 100 w, E, "The Daytime Station."

WMBJ

1500 kc, Wilkesburg, Pa., Rev. J. W. Sproul, 100, E.

WMBL

1310 kc, Lakeland, Fla., Benford's Radio Studios, 100 w, E, "Lakeland—The City of Heart's Desire."

WMBO

1370 kc, Auburn, N. Y., Radio Service Laboratories, 100 w, E.

WMBQ

1500 kc, Brooklyn, N. Y., Paul J. Gollhofer, 100 w, Shared.

WMBR

1210 kc, Tampa, Fla., F. J. Reynolds, 100 w, E, "WMBR, Everything for Radio at Tampa, Fla."

WMB S

1430 kc, Lemoynne, Pa., Mack's Battery Co., 500 w, E. Shared.

WMC

780 kc, Memphis, Tenn., Memphis Commercial Appeal, Inc., 500 w, C, "WMC, Memphis, Down in Dixie."

WMCA

570 kc, Hoboken, N. J., Greeley Square Hotel Co., 500 w, E, shared, "Where the White Way Begins."

WMES

1500 kc, Boston, Mass., Massachusetts Educational Society, 50 w. Shared.

WMMN

890 kc, Fairmont, W. Va., Holt Rome Novelty Co., 250 w, E.

WMPC

1500 kc, Lapeer, Mich., First Methodist Protestant Church, 30 w, E, "Where Many Preach Christ."

WMRJ

1420 kc, Jamaica, N. Y., Peter J. Prinz, 10 w, E, shared, "The Gateway of the Sunrise Trail."

Each of these plans, developed by the Radio Association of America, is a big money-maker. Set owners everywhere want to get rid of static, to have their sets operate from the electric light socket, the tone improved, and the volume increased, and transformed into single-dial controls. Phonograph owners want their machines electrified and radiofied. If you learn to render these services, you can easily make \$3.00 an hour for your spare time, to say nothing of the money you can make installing, servicing, repairing, building radio sets, and selling supplies.

Over \$600,000,000 is being spent yearly for sets, supplies, service. You can get your share of this business and, at the same time, fit yourself for the big-pay opportunities in Radio by joining the Association.

Join the Radio Association of America

A membership in the Association offers you the easiest way into Radio. It will enable you to earn \$3.00 an hour upwards in your spare time—train you to install, repair and build all kinds of sets—start you in business without capital or finance an investment—train you for the \$3,000 to \$10,000 big-pay radio positions—help secure a better position at bigger pay for you.

A membership need not cost you a cent!
The Association will give you a comprehensive, practical, and theoretical training and the benefit of its Employment Service. You earn while you learn. Our cooperative plan will make it possible for you to establish a radio store. You have the privilege of buying radio supplies at wholesale from the very first.

Earned \$500.00 Spare Time
Frank J. Deutsch, Penn.: "I have made over \$500 out of Radio in my spare time."

Radio Engineer In One Year
Claude De Grave, Canada: "I knew nothing about Radio when I joined a year ago. I am now a member of a very exclusive organization of Radio Engineers, and my income is 225% greater than it was."

Doubles Income In 6 Months
W. E. Thon, Chicago: "Six months after I enrolled I secured the managership of large Radio Store and doubled my income."

ACT NOW — If You Wish the No-Cost Membership Plan

To a limited number of ambitious men, we will give Special Memberships that may not—need not—cost you a cent. To secure one, write today. We will send you details and also our Radio Handbook filled with dollars-and-cents radio ideas. It will open your eyes to the money-making possibilities of Radio.

Radio Association of America
4513 Ravenswood Ave., Dept. RCB-3 Chicago, Ill.

Radio Association of America
Dept. RCB-3 4513 Ravenswood Ave., Chicago, Ill.

Gentlemen: Please send me by return mail full details of your Special Membership Plan, and also copy of your Radio Handbook.

Name.....

Address.....

City..... State.....

WMSG

1350 kc, New York, N. Y., Madison Square Garden Broadcast Co., 250 w, E. Shared.

WMT

1200 kc, Waterloo, Iowa, Waterloo Broadcasting Co., 100 w, C. Shared.

WNAC

1230 kc, Boston, Mass., The Shepard Norwell Co., 500 w, E.

WNAD

1010 kc, Norman, Okla., University of Oklahoma 500 w, C, shared, "The Voice of Soonerland."

WNAT

1310 kc, Philadelphia, Pa., Lenning Brothers Co., 100 w, E.

WNAX

570 kc, Yankton, S. Dak., Gurney Seed & Nursery Co., Dakota Radio Apparatus Co., 1000 w, C. Shared.

WNBF

1500 kc, Binghamton, N. Y., Howitt-Wood Radio Co., 50 w, E. "The Voice of the Triple Cities."

WNBH

1310 kc, New Bedford, Mass., New Bedford Broadcasting Co., 100 w, E, shared, "The Gateway to Cape Cod."

WNBJ

1310 kc, Knoxville, Tenn., Lonsdale Baptist Church, 50 w, C.

WNBR

1430 kc, Memphis, Tenn., John Ulrich, 500 w, C. Shared.

WNBW

1200 kc, Carbondale, Pa., Home Cut Glass & China Co., 5 w, E.

WNBX

1200 kc, Springfield, Vt., First Congregational Church, Inc., 10 w, E. Shared.

WNBZ

1290 kc, Saranac Lake, N. Y., Smith & Mace, 10 w, daytime, E.

WNJ

1450 kc, Newark, N. J., Radio Investment Co., 250 w, E, shared. "The Voice of Newark."

WNOX

560 kc, Knoxville, Tenn., Stercki Bros., 1000 w, C, shared, "Smoky Mountain Station."

WNRC

1440 kc, Greensboro, N. C., Wayne M. Nelson, 500 w, E.

WNYC

570 kc, New York, N. Y., Department of Plant & Structures, 500 w, E, shared, "Municipal Broadcasting Station of the City of New York."

WOAI

1190 kc, San Antonio, Texas, Southern Equipment Co., 5000 w, C, shared, "The Winter Playground of America."

WOAN

600 kc, Lawrenceburg, Tenn., Church of the Nazarene & Vaughan School of Music, 500 w, C, shared, "Watch Our Annual Normal."

WOAX

1280 kc, Trenton, N. J., Franklyn J. Wolff, 500 w, E, shared, "Trenton Makes, the World Takes."

WOBT

1310 kc, Union City, Tenn., Tittsworth's Radio & Music Shop, 15 w, C.

WOBU

580 kc, Charleston, W. Va., Charleston Radio Broadcasting Co., 250 w, E. Shared.

WOC

1000 kc, Davenport, Iowa, Palmer School of Chiropractic, 5000 w, C. Shared.

WOCL

1210 kc, Jamestown, N.Y., A. E. Newton, 25 w, E.

WODA

1250 kc, Paterson, N. J., Richard E. O'Dea, 1000 w, E, "The Voice of the Silk City."

WOI

560 kc, Ames, Iowa, Iowa State College, 3500 w, C. Shared.

WOKO

1440 kc, Mt. Beacon, N. Y., Harold E. Smith, 500 w, E. Shared.

WOL

1310 kc, Washington, D. C., American Broadcasting Co., 100 w, daytime, E.

WOMT

1210 kc, Manitowoc, Wis., Mikado Theater, 100 w.

WOOD

1270 kc, Grand Rapids, Mich., Walter B. Stiles, Inc., 500 w, C, shared, "The Voice of the Whispering Pines."

WOQ

610 kc, Kansas City, Mo., Unity School of Christianity, 1000 w, C. Shared.

WOR

710 kc, Newark, N. J., L. Bamberger & Co., 5000 w, E.

WORD

1480 kc, Batavia, Ill., People's Pulpit Association, 5000 w, C, shared, "The Watch Tower—Radio WORD."

WOS

630 kc, Jefferson City, Mo., State Marketing Bureau, 500 w, C, shared, "Watch Our State."

WOV

1130 kc, New York, N. Y., International Broadcasting Corp., 1000 w, E.

WOW

590 kc, Omaha, Neb., Woodmen of the World, 1000 w, C, shared, "The Omaha Station."

WOWO

1160 kc, Ft. Wayne, Ind., Main Auto Supply Co., 10,000 w, C. Shared.

WPAP

See under WQAO.

WPAW

1210 kc, Pawtucket, R. I., Shartenberg & Robinson, 100 w, E, "The City of Diversified Industries." Shared.

WPCC

570 kc, Chicago, Ill., North Shore Congregational Church, 500 w, C. Shared.

WPCH

810 kc, New York, N. Y., Concourse Radio Corp., 500 w.

WPG

1100 kc, Atlantic City, N. J., Municipality of Atlantic City, 5000 w, E. Shared.

WPOR

See under WTAR.

WPRC

1200 kc, Harrisburg, Pa., Wilson Printing & Radio Co., 100 w, E.

WPSC

1230 kc, State College, Pa., Pennsylvania State College, 500 w, day, E, "The Voice of the Nittany Lion."

WPSW

1500 kc, Philadelphia, Pa., Philadelphia School of Wireless Telegraphy, 50 w, E, "First Wireless School in America."

WPTF

680 kc, Raleigh, N. C., Durham Life Insurance Co., 10,000 w, E. Shared.

WQAM

1240 kc, Miami, Fla., Miami Broadcasting Co., 750 w, E. Shared.

WQAN

880 kc, Scranton, Pa., Scranton Times, 250 w, E. Shared.

WQAO

1010 kc, New York, N. Y., Calvary Baptist Church, 250 w, E.

WQBC

1360 kc, Utica, Miss., Utica Chamber of Commerce, 300 w, C.

WQBZ

1420 kc, Vierton, W. Va., J. H. Thompson, 60 w, E.

WRAF

1200 kc, La Porte, Ind., The Radio Club, Inc., 100 w. Shared.

WRAC

1370 kc, Erie, Pa., C. R. Cummins, 50 w, E.

WRAW

1310 kc, Reading, Pa., Avenue Radio & Electric Shop, 100 w, E, "The Schuylkill Valley Echo."

WRAX

1020 kc, Philadelphia, Pa., Berachah Church, Inc., 250 w, E.

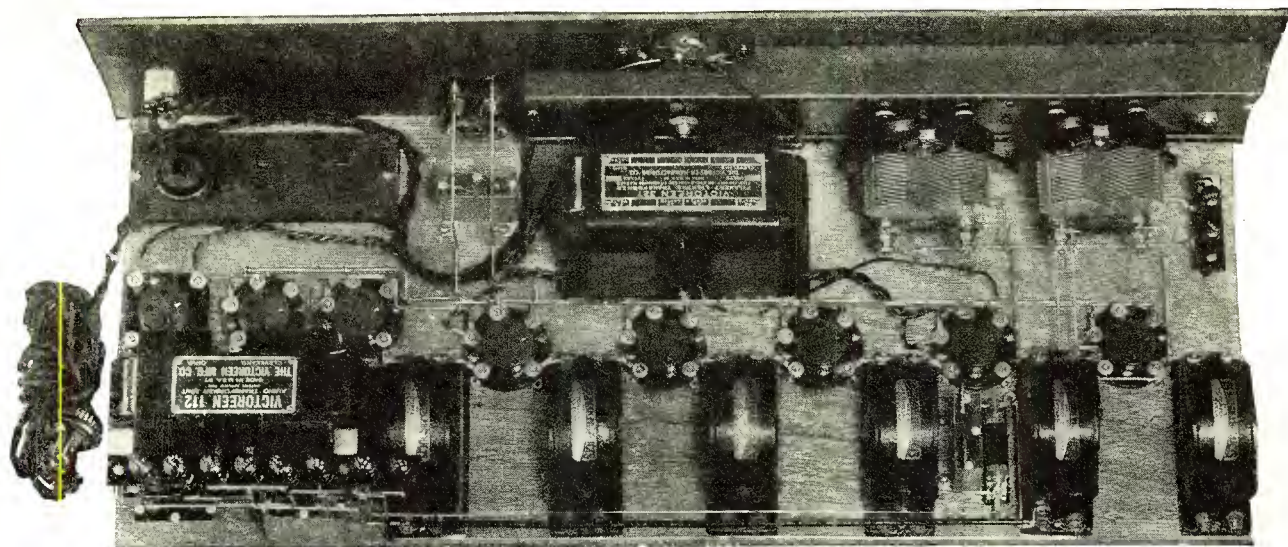

**A Better Receiver Cannot Be Built or Bought, than
 he 1929 A. C. VICTOREEN
 The Master Super Heterodyne**

ONE builder writes "the most marvelous tone quality I have ever head." Another, "Its selectivity is marvelous, it is razor sharp even on the most powerful stations." And another builder writes from the Middle West, "California stations come in almost like locals. I even get Honolulu occasionally."

There is absolutely nothing that you can ask of a Radio Receiver that Victoreen does not give. And—it is a proven fact, that, despite the exceptional factory built sets available you can still build better than you can buy.

When you build a Victoreen for yourself or for sale, you have the absolute satisfaction of knowing that there is nothing better made. You also have the satisfaction of knowing that improvements, as they are developed, can be added to a Victoreen Super Heterodyne easily,

and at small cost.

Just as the Super Heterodyne is the master circuit, so is Victoreen the master "Super." If you want the best you must have the Victoreen.

Blue Print, giving full constructional details, FREE

**Victoreen Power Amplifier
 and "B" Supply**

Here is the last word in "B" Power Supply and Power Amplifiers. Uses either a UX 250 or 210 in the last stage. Two voltage regulator tubes accurately control the 90 and 180 volt taps, thus making possible accurate determination of proper "C" voltages. There is also a 0 to 90 volt tap, variable; also 450 volts for the power tube.

Blue Print is FREE, together with list of parts and complete assembly instructions. Write for it today.

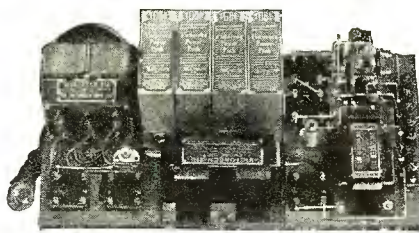

Complete Victoreen Kits
 Now Available to Set
 Builders at Net Prices.

THE GEO. W. WALKER COMPANY
 Merchandisers of Victoreen Radio Products
 2825 Chester Ave., Cleveland, Ohio

Write for Complete Cata-
 log of Victoreen Products.

Victoreen
 STANDARDIZED HIGH QUALITY RADIO PARTS

WRBC

1240 kc, Valparaiso, Ind., Immanuel Lutheran Church, 500 w, C, "World Redeemed by Christ."

WRBJ

1500 kc, Hattiesburg, Miss., Woodruff Furniture Co., 10 w, C.

WRBL

1200 kc, Columbus, Ga., Roy E. Martin, 50 w, E.

WRBQ

1210 kc, Greenville, Miss., J. Pat Scully, 100 w, C.

WRBT

1370 kc, Wilmington, N. C., Wilmington Radio Association, 50 w, E.

WRBU

1210 kc, Gastonia, N. C., A. J. Kirby Music Co., 100 w, E.

WRC

950 kc, Washington, D. C., Radio Corporation of America, 500 w, E, "The Voice of the Capital."

WREC

600 kc, Whitehaven, Tenn., WREC, Inc., 500 w, Shared.

WREN

1220 kc, Lawrence, Kan., Jenny Wren Co., 1000 w, C, Shared.

WRHM

1250 kc, Fridley, Minn., Rosedale Hospital Co. Inc., 1000 w, C, shared, "Welcome Rosedale Hospital, Minneapolis."

WRJN

1370 kc, Racine, Wis., Racine Broadcasting Corp., 100 w, C, Shared.

WRK

1310 kc, Hamilton, Ohio, S. W. Doron & John C. Slade, 100 w, E, "The Voice of Hamilton."

WRNY

1010 kc, New York, N. Y., Experimenter Pub. Co., 250 w, E, Shared.

WRR

1280 kc, Dallas, Texas, City of Dallas, 500 w, C, Shared.

WRUF

1470 kc, Gainesville, Fla., University of Florida, 5000 w, E, Shared.

WRVA

1110 kc, Richmond, Va., Larus Bros. & Co., Inc., 5000 w, E, "Carry Me Back to Old Virginy."

WSAI

800 kc, Mason, Ohio, Crosley Radio Corp., 5000 w, E, shared, "The Gateway to Dixie."

WSAJ

1310 kc, Grove City, Pa., Grove City College, 100 w, E.

WSAN

1440 kc, Allentown, Pa., Allentown Call Pub. Co., 250 w, E, shared, "We Serve Allentown Nationality."

WSAR

1450 kc, Fall River, Mass., Doughty & Welch Electrical Co., Inc., 250 w, E, Shared.

WSAZ

580 kc, Huntington, W. Va., McKellar Electric Co., 250 w, E, Shared.

WSB

740 kc, Atlanta, Ga., Atlanta Journal Co., 10,000 w, E, "The Voice of the South."

WSBC

1210 kc, Chicago, Ill., World Battery Co., Inc., 100 w, Shared.

WSBT

1230 kc, South Bend, Ind., South Bend Tribune, 500 w, C, Shared.

WSDA

See under WSGH.

WSEA

780 kc, Portsmouth, Va., Virginia Broadcasting Co., Inc., 500 w, E, shared, "The Voice of Tidewater Virginy."

WSGH

1400 kc, Brooklyn, N. Y., Amateur Radio Specialty Co., 500 w, Shared.

WSIS

1010 kc, Sarasota, Fla., Sarasota Chamber of Commerce, 250 w, E, "The Pioneer Semi-Tropical Business Journal."

WSIX

1210 kc, Springfield, Tenn., 638 Tire & Vulcanizing Co., 100 w, C.

WSM

650 kc, Nashville, Tenn., National Life & Accident Ins. Co., 5000 w, C, "We Shield Millions."

WSMB

1320 kc, New Orleans, La., Saenger Theaters, Inc., & Maison Blanche Co., 500 w, C, "America's Most Interesting City."

WSMD

1310 kc, Salisbury, Md., Tom F. Little, 100 w, E.

WSMK

570 kc, Dayton, Ohio, Stanley M. Krohn, Jr., 200 w, C, "The Home of Aviation."

WSPD

1340 kc, Toledo, Ohio, Toledo Broadcasting Co., 500 w, E, Shared.

WSRO

1420 kc, Middletown, Ohio, Harry W. Fahrlander, 100 w, C, "We Sell Radio Only."

WSSH

1420 kc, Boston, Mass., Tremont Temple Baptist Church, 100 w, E, shared, "Stranger's Sunday Home."

WSUI

580 kc, Iowa City, Iowa, State Univ. of Iowa, 500 w, C, shared, "The Old Gold Studio."

WSUN

See under WFLA.

WSVS

1370 kc, Buffalo, N. Y., Seneca Vocational School, 50 w, E, "Watch Seneca Vocational School."

WSYR

570 kc, Syracuse, N. Y., Clive B. Merewith, 250 w, E, Shared.

WTAD

1440 kc, Quincy, Ill., Illinois Stock Medicine Broadcasting Corp., 500 w, Shared.

WTAG

580 kc, Worcester, Mass., Worcester Telegram Pub. Co., Inc., 250 w, E, "The Voice From the Heart of the Commonwealth."

WTAM

1070 kc, Cleveland, Ohio, WTAM & WEAR, Inc., 3500 w, E, shared, "The Voice From the Storage Battery."

WTAQ

1330 kc, Eau Claire, Wis., Gillette Rubber Co., 1000 w, C, Shared.

WTAR

780 kc, Norfolk, Va., WTAR Radio Corp., 500 w, E, Shared.

WTAW

1120 kc, College Station, Texas, Agri. & Mech. College of Texas, 500 w, C, Shared.

WTAX

1210 kc, Streator, Ill., Williams Hardware Co., 50 w, Shared.

WTBO

1420 kc, Cumberland, Md., Cumberland Electric Co., 50 w, E.

WTFI

1450 kc, Toccoa, Ga., Toccoa Falls Institute, 500 w, E.

WTIC

600 kc, Hartford, Conn., Travelers Insurance Co., 250 w, E, shared, "The Insurance City."

WTMJ

620 kc, Brookfield, Wis., Milwaukee Journal, 1000 w, C, Shared.

WWAE

1200 kc, Hammond, Ind., Hammond-Calumet Broadcasting Corp., 100 w.

WWJ

920 kc, Detroit, Mich., The Detroit News, 1000 w, E.

WWL

850 kc, New Orleans, La., Loyola University, 500 w, C, Shared.

WWNC

570 kc, Asheville, N. C., Chamber of Commerce, 1000 w, E.

WWRL

1500 kc, Woodside, N. Y., Wm. H. Rouman, 100 w, Shared.

WWVA

1160 kc, Wheeling, W. Va., West Virginia Broadcasting Corp., 250 w, E, Shared.

**A YEAR
AHEAD
WITH**

MINERVA

**A. Completely
Shielded Receiver**

~
**REMEMBER THE
TONE**

~
**THE 1929
SENSATION**

~
**Pay Half the Price
of Its Nearest Rival**



**All Electric
8 Tubes**

~
Liberal Discounts

~
**Become a MINERVA
Franchised Dealer**

~
**WE BACK YOU 100%
Write for Particulars**

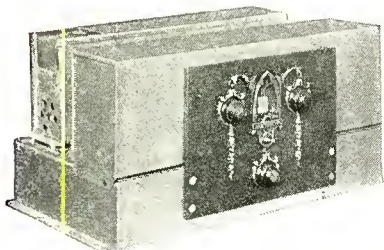

MINERVA CHASSIS

WE WANT AGENTS for this remarkable MINERVA RECEIVER. The Radio Industry is growing by leaps and bounds. NOW IS YOUR CHANCE TO MAKE REAL MONEY.

Represent the MINERVA All-Electric Set in your community. Many beautiful models at real prices.

ACT NOW!

MARWOOD DYNAMIC

We offer a DYNAMIC SPEAKER that will amaze you with its wonderful tone quality, tremendous volume, reproducing all tones perfectly.

INCREASE YOUR EARNINGS 100% by selling this popular DYNAMIC in your locality. We protect your franchise. We give you desired territory. BE FIRST TO SELL A DYNAMIC SPEAKER THAT WILL OUTPERFORM ANY OTHER ON THE MARKET. Send for sample and be convinced. Made in all models. Supplied in beautiful consoles.

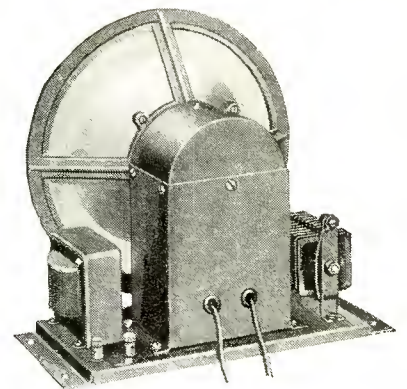

MARWOOD 110V 60 CYCLE DYNAMIC CHASSIS.....\$19.75
90V DC or 6V DC DYNAMIC CHASSIS..... 18.00

MILLER-WELLES CO.
INCORPORATED

14-20 West Kinzie Street
CHICAGO, ILL.

Write for Our Free Wholesale Radio
Television Catalogue

THE MILLER-WELLES CO., Inc.
Dept. 100H, 14-20 W. Kinzie St.
Chicago, Illinois.

Without obligation, send full particulars and prices.
Check proposition below.

Dealer Agent User
MINERVA FRANCHISE
 Dealer Agent User
MARWOOD DYNAMIC SPEAKER
 RADIO—TELEVISION, CATALOGUE

Name

Address

U. S. Broadcasting Stations Listed by States

ALABAMA

Birmingham, WBRC, WKBC, WAFB
Gadsden, WJBY
Montgomery, WIBZ

ALASKA

Anchorage, KFQD
Juneau, KFIU
Ketchikan, KGBU

ARIZONA

Flagstaff, KFXV
Phoenix, KFAD, KFQB
Prescott, KPJM
Tucson, KGAR

ARKANSAS

Blytheville, KLCN
Fayetteville, KUOA
Hot Springs, KTHS
Little Rock, KLRA, KGHI, KGFJ
McGehee, KGHG
Siloam Springs, KFPW

CALIFORNIA

Berkeley, KRE
Beverly Hills, KEJK
Burbank, KELW
Culver City, KFVD
El Centro, KKO
Fresno, KML
Glendale, KGFH
Hayward, KZM
Hollywood, KFQZ, KMTR, KXX
Holy City, KFQU
Inglewood, KMIC
Long Beach, KFOX, KGER
Los Angeles, KEJK, KFI, KFSG, KGEF, KFWB, KGFJ, KHI, KPLA, KTBI
Oakland, KFWM, KGO, KLS, KLB, KLTAB
Ontario, KFQC
Pasadena, KPFC, KPNS
Sacramento, KFBK
San Diego, KFSB, KGB
San Francisco, KTRC, KFVI, KFTT, KJBS, KPO, KYA
San Jose, KQW
Santa Ana, KWTC
Santa Barbara, KDB
Santa Maria, KSJR
Santa Monica, KTM
Stockton, KGD, KWG
Westminster, KPWF

COLORADO

Colorado Springs, KFUM
Denver, KFEL, KFUP, KFXF, KOA, KOW, KPWF
Dupont, KIZ
Edgewater, KFXJ
Fort Morgan, KGEW
Greeley, KFA
Gunnison, KFHA
Pueblo, KGHV
Trinidad, KGHW
Yuma, KGEK

CONNECTICUT

Easton, WICC
Hartford, WVIC
New Haven, WDRC
Storrs, WCAC

DELAWARE

Wilmington, WDEL, WILM

DISTRICT OF COLUMBIA

Washington, NAA, WMAL, WRC, WRHF

FLORIDA

Clearwater, WFLA
Gainesville, WRUF
Jacksonville, WJAX
Lakeland, WMLB
Miami Beach, WIOD, WMFB, WQAM
Orlando, WDRO
Pensacola, WCOA
Sarasota, WSIS
Tampa, WDAE, WMBR

GEORGIA

Atlanta, WGST, WSB
Columbus, WRBL
Macon, WMAZ
Toccoa, WTEF

HAWAII

Honolulu, KGHB, KGU

IDAHO

Boise, KFAU
Idaho Falls, KGIO
Jerome, KFXD
Pocatello, KSEI
Sandpoint, KGKX
Twin Falls, KGIQ

ILLINOIS

Batavia, WORD
Carthage, WCAZ
Chicago, KYW, WAAF, WCFM, WCRW, WEDC, WENR, WGES, WKBI, WPCB, WSBC, WGN, WMAQ, WMBI, WBBM, KYWA
Cicero, WHFC
Crete, WLS
Deerfield, WJBL
Des Plaines, WIBO
Evanston, WEHS
Galesburg, WLEB, WKBS
Harrisburg, WEBQ
Joliet, WOLS, WKBB
La Salle, WJBC
Mooseheart, WJJD
Mt. Prospect, WJAZ
Peoria Heights, WMBD
Quincy, WTAD
Rockford, KFLV
Rock Island, WHBF
Springfield, WCBS
Streator, WTAX
Tuscola, WIZ
Urbana, WLL
Zion, WCBD

INDIANA

Anderson, WHBU, WKBY
Brookville, WKBY
Crown Point, WLBT
Culver, WCMA
Evansville, WGFB
Fort Wayne, WGL, WOWO
Gary, WJKS
Hammond, WVAE
Indianapolis, WFBI, WKBF, Kokomo, WJAK
La Porte, WRAF
Muncie, WIBC
South Bend, WSBT
Terre Haute, WBOW
Valparaiso, WRBC
Lafayette, WBAA

IOWA

Ames, WOI
Boone, KFGQ
Cedar Rapids, KWCR
Clarinda, KSO
Council Bluffs, KOIL
Davenport, WOC
Decorah, KGCA, KWLO
Des Moines, WHO, Ft. Dodge, KEFV
Iowa City, WSUI
Marshalltown, KFJB
Muscatine, KNTN
Ottumwa, WTAS
Red Oak, KIC
Shenandoah, KFNF, KMA
Sioux City, KSCJ
Waterloo, WMT

KANSAS

Concordia, KGCN
Lawrence, KFBU, WREN
Manhattan, KSAO
Milford, KFQB
Topeka, WFBV
Wichita, KFH

KENTUCKY

Hopkinsville, WFTW
Louisville, WHAS, WLAP

LOUISIANA

Cedar Grove, KGGH
Kennonwood, KWKH
New Orleans, WABZ, WJBO, WJBW, WWL, WDSU
Shreveport, KSBA, KWEA, KRMD

MAINE

Bangor, WABL, WLBZ
Portland, WCSH

MARYLAND

Baltimore, WCAO, WCBM, WBAL, WFBR
Cumberland, WTBO
Glen Morris, WBAL
Salisbury, WSMO

MASSACHUSETTS

Boston, WBZA, WEEI, WNAC, WSSH, WMES
Chelsea, WLOE
Dartmouth, WMAF
East Springfield, WBZ
Fall River, WVAS
Gloucester, WEPS, WHDH
Lexington, WLEX
Medford, WBET
New Bedford, WNBH

Webster, WKBE
Wellesley Hills, WBSO
Worcester, WTAG

MICHIGAN

Battle Creek, WKBP
Bay City, WBCM
Berrien Springs, WEMC
Calumet, WHDF
Detroit, WAFD, WMBC, WJW, WJR
East Lansing, WKAR
Flint, WFDF
Fraser, WFRP
Grand Rapids, WASH, WOOD
Jackson, WIBM
Lapeer, WMPG
Ludington, WKBZ
Royal Oak, WAGM
Ypsilanti, WJBK

MINNESOTA

Anoka, WCCO
Collegeville, WFBJ
Fergus Falls, KGDE
Fridley, WRHM
Hallock, KGFK
Minneapolis, WDSY, WHDI, WLB
Northfield, KFMX, WCAL
Westcott, KSTP

MISSISSIPPI

Columbus, WCOO
Greenville, WRBQ
Gulfport, WCGM
Hattiesburg, WRBJ
Utica, WQBC

MISSOURI

Cape Girardeau, KFVS
Columbia, KFRU
Independence, KMBC
Jefferson City, WOS
Joplin, WMBH
Kansas City, KWKC, WDAF, WFB, WLBF, WOQ
Kirksville, KFZZ
St. Joseph, KGBX, KFEQ
St. Louis, KFWE, KSD, KWK, WEW, WIL, WMAV, KMOX, KFUO

MONTANA

Billings, KGHL
Butte, KQPR
Great Falls, KFBB
Kalispell, KGEZ
Missoula, KUOM, KGHD
Vida, KGKX

NEBRASKA

Clay Center, KMMJ
Lincoln, KFAB, KFOR, WCAJ
Norfolk, WJAG
Omaha, WAAW, WOW
Ravenna, KGFV
York, KGBZ

NEVADA

Reno, KOH

NEW HAMPSHIRE

Laconia, WKAV
Tilton, WBLV

NEW JERSEY

Asbury Park, WCAP
Atlantic City, WPG
Camden, WCAM
Chilside Park, WODA
Elizabeth, WBS
Fort Lee, WBMS
Hoboken, WMCA, WPCH
Jersey City, WAAT, WKRO
Newark, WAAW, WGCP, WNJ, WOR
Paterson, WODA
Red Bank, WJBI
Secaucus, WOY
Trenton, WOAX

NEW MEXICO

Albuquerque, KGGM
Raton, KGFL
State College, KOB

NEW YORK

Astoria, WGBS
Auburn, WMBO
Bay Shore, WINR
Bellmore, WEAF
Binghamton, WNBZ
Brooklyn, WBBC, WLTH, WMBQ, WSGH
Buffalo, WFBZ, WGR, WKBW, WKEN, WSVS
Canton, WCAD
Cazenovia, WMAZ
Coney Island, WCGU

Farmingdale, WLBH
Freeport, WGBE
Greenville, WCOH
Ithaca, WLCI, WEAI
Jamaica, WMIJ
Jamestown, WOCL
Long Beach, WCLB
Long Island City, WLBX
Marshallville, WIAK
Mt. Beacon, WOKO
New York, WBNY, WHN, WJZ, WKBO, WMCA, WMSG, WNYC, WPCB, WRNY, WABC, WOV

NORTH CAROLINA

Asheville, WWNC
Charlotte, WBT
Gastonia, WRBU
Greensboro, WNRO
Raleigh, WPTF
Wilmington, WRBT

NORTH DAKOTA

Bismarck, KFYR
Devils Lake, KDLL
Fargo, WDAY
Grand Forks, KFJM
Mandan, KGGU

OHIO

Akron, WADC, WFIC
Bellefontaine, WHBD
Canton, WHRC
Cambridge, WEBE, WBEA
Cincinnati, WAAD, WKRC
Cleveland, WEAR, WHK, WJAY, WTAM
Columbus, WAUC, WEAQ, WMAN
Dayton, WSNR
Hamilton, WRK
Mansfield, WLBY
Nason, WSAI, WLW
Middleton, WSRO
Springfield, WCSO
Steubenville, WIBR
Toledo, WSPD
Youngstown, WKBN

OKLAHOMA

Alva, KGEF
Chickasha, KOCW
Enid, KGCB
Norman, WNAD
Oklahoma City, KFJF, KFJR, KGCB, KGFV, WKY
Picher, KGGP
Ponca City, WBBZ
Tulsa, KVOO

OREGON

Astoria, KFJI
Corvallis, KOAC
Eugene, KORE
Marshallfield, KOOS
Medford, KMEB
Portland, KEX, KOIN, KFEC, KFIE, KFIR, KGW, KXLB, KWBS, KWJJ

PENNSYLVANIA

Allentown, WCBA, WSAW
Altoona, WFBG
Carbondale, WNBW
East Pittsburgh, KDKA
Elkins Park, WIRG
Erie, WEDH, WRAK
Frankford, WFKD
Greene City, WSAJ
Harrisburg, WRAP, WPRC
Johnstown, WHBP
Lancaster, WGAL, WKJC
Le Moyne, WMBS
Lewisburg, WJBU
Oil City, WLBW
Philadelphia, WCAU, WFL, WHT, WHT, WNT, WOP, WRAX, WPSW, WFAN, WELK
Pittsburgh, KQV, WCAE, WJAS
Reading, WRAW
Scranton, WGRI, WQAN, State College, WPSC
Wilkes-Barre, WYAX, WBRE
Wilkesburg, WMBR
Willow Grove, WALK
Washington, WNBO

PORTO RICO

San Juan, WKAQ

RHODE ISLAND

Cranston, WDFW
Newport, WABA
Pawtucket, WPAW
Providence, WEAN, WJAR

SOUTH CAROLINA

Charleston, WBBY

SOUTH DAKOTA

Brookings, KFDD, KGCC
Dell Rapids, KGDA
Oldham, KGDY
Pierre, KGFX
Rapid City, WCAT
Sioux Falls, KSOO
Vermillion, KUSD
Yankton, WNAW

TENNESSEE

Chattanooga, WDOE
Knoxville, WPCB, WNBZ, WNOX
Lawrenceburg, WOAN
Memphis, WGBZ, WBRQ, WMC
Nashville, WBAW, WLAC, WSM
Springfield, WSIX
Union City, WOBZ
White Haven, WREC

TEXAS

Ableene, KFYO
Amarillo, KGRS, WDAG
Austin, KUT
Beaumont, KFDM
Brownsville, KWVG
Brownwood, KGKB
College Station, WTAW
Dallas, KRLD, WFAA, WRR
Dublin, KEPL
El Paso, WDAH
Forth Worth, KFJZ, WBAP, KTAT
Galveston, KFLX, KFUL
Georgetown, KGKL
Goldsmith, KCKB
Greenville, KFPM
Harlingen, KRGV
Houston, KPRC, KTUE
Richmond, KGHX
San Angelo, KGFJ, KGKL
San Antonio, KGCI, KGDR, KRGK, KTAP, KTSB, WQAI
Waco, WJAD
Wichita Falls, KGKO

UTAH

Odgen, KFUR
Salt Lake City, KDYL, KSL

VERMONT

Burlington, WCAX
Springfield, WNBX

VIRGINIA

Arlington, NAA
Chesterfield Hills, WTAZ
Mt. Vernon Hills, WJSV
Newport News, WGH
Norfolk, WTAZ
Petersburg, WLBG
Portsmouth, WSEA
Richmond, WBBL, WMBG, WRVA
Roanoke, WDBJ, WRBX

WASHINGTON

Aberdeen, KXOB
Bellingham, KVOS
Everett, KFBL
Lacey, KGY
Longview, KJL
Pullman, KWSC
Seattle, KOL, KFQW, KPO, KJR, KKP, KOMO, KPBR, KRSC, KTW, KVL, KXA
Spokane, KFIO, KFPY, KGA, KHQ
Tacoma, KMO, KVI

WEST VIRGINIA

Charleston, WGRU
Fairmont, WMMN
Huntington, WSAZ
Martinsburg, WQZB
Wheeling, WVVA

WISCONSIN

Appleton, WAIZ
Beloit, WBEV
Brookfield, WTMJ
Eau Claire, WTAQ
Fond Du Lac, KFIZ
Kenosha, WGLD
La Crosse, WKBB
Madison, WHA, WIBA
Manitowac, WMT
Milwaukee, WGWV, WHAD, WISN
Poyntette, WIRU
Racine, WRIN
Shaboygan, WHBL
Stevens Point, WBLB
Superior, WBCB
West De Pere, WHBY

WYOMING

Laramie, KYWO

Now...4 or 6 Volts with the Improved Knapp "A" POWER

The only "A" Power suitable for all sets — irrespective of number of tubes — including SuperHets, Short Wave and Television receivers.

THE new Knapp "A" Power is designed for the most exacting service — super-hets, short wave and television receivers

included. I knew that if it would perform satisfactorily with these receivers that there could be no question as to its efficiency on ordinary broadcast signals. The three Elkon dry condensers, the improved choke coils and the special Elkon dry rectifier make the difference between ordinary and Knapp performance.

No Change in Price

Even with these wonderful and costly improvements, there has been no advance in price — due to the tremendous volume going thru my plant. Remember that the Knapp is the fastest selling "A" Power on the market.

KNAPP ELECTRIC, Inc.,
—Division of P. R. Mallory & Co., Inc.—
350 Madison Ave., New York City



10

Improvements

1. Two taps for 4 or 6 volt operation.
2. Larger filter system.
3. Three Elkon Dry Condensers instead of two.
4. Improved Choke Coils.
5. Pendant Switch Controlling "A" Power, "B" Eliminator and Set.
6. Dial for Regulating Voltage.
7. Celeron Front Panel.
8. Baked Finish.
9. Heavier Gauge Metal Cover.
10. Die Cast Base Plate instead of wood.

See your dealer today

Go to your dealer today. Most of the good ones carry the Knapp in stock. Do not accept a substitute — because only in the Knapp will you get full satisfaction as typified by the famous Knapp "A" Power. If your dealer cannot supply you send the coupon.



Mr. David W. Knapp, Pres.,
Knapp Electric, Inc., Dept. K-17
350 Madison Ave., N. Y. C.
Send me complete information on the Knapp
"A" Power.

U. S. Broadcasting Stations by Frequencies

550 Kilocycles, 545.1 Meters:
WEAN, WGR, WEAQ, WKRC, KFUO, KSD, KFDY, KFJR, KTAB

560 Kilocycles, 535.4 Meters:
WLIT, WFI, KFDM, WMBF, WNOX, WOI, KFEQ, KOAC, KLZ

570 Kilocycles, 526.0 Meters:
WNYC, WMCA, WSYR, WMAC, WSMK, WKBN, WWNC, KGKO, WHA, WNAX, WPCC, WIBO, KUOM, KXA, KMTR, KPLA

580 Kilocycles, 516.9 Meters—Canadian Shared:
WTAG, WOBW, WSAZ, KGFX, KSAC, WSUI

590 Kilocycles, 508.2 Meters:
WEEI, WEMC, WCAJ, WOW, KHQ

600 Kilocycles, 499.7 Meters—Canadian Shared:
WTIC, WCAO, WREC, WOAN, WEBW, KSSD, KYWO, WCAC

610 Kilocycles, 491.5 Meters:
WFAN, WIP, WDAF, WOQ, KFRC

620 Kilocycles, 483.6 Meters:
WLBZ, WDBO, WDAE, WTMJ, KGW, KFAD

630 Kilocycles, 475.9 Meters—Canadian Shared:
WMAL, WOS, KFRU, WGBF

640 Kilocycles, 468.5 Meters:
WAU, KFI

650 Kilocycles, 461.3 Meters:
WSM

660 Kilocycles, 454.3 Meters:
WEAF, WAAW

670 Kilocycles, 447.5 Meters:
WMAQ

680 Kilocycles, 440.9 Meters:
WPTF, KPO

690 Kilocycles, 434.5 Meters—Canadian Wave:

700 Kilocycles, 428.3 Meters:
WLW, KFVD

710 Kilocycles, 422.3 Meters:
WOR

720 Kilocycles, 416.4 Meters:
WGN, WLIB

730 Kilocycles, 410.7 Meters—Canadian Wave:

740 Kilocycles, 405.2 Meters:
WSB, KMMJ

750 Kilocycles, 399.8 Meters:
WJR, WCX

760 Kilocycles, 394.5 Meters:
WJZ, WEW

770 Kilocycles, 389.4 Meters:
KFAB, WBBM, WJBT

780 Kilocycles, 384.4 Meters—Canadian Shared:
WBSO, WSEA, WTAR, WPOR, WMC, KELW, KTM

790 Kilocycles, 379.5 Meters:
WGY, KGO

800 Kilocycles, 374.8 Meters:
WSAI, WBAP, KTHS

810 Kilocycles, 370.2 Meters:
WPCH, WCCO

820 Kilocycles, 365.6 Meters:
WHAS

830 Kilocycles, 361.2 Meters:
KOA, WHDH

840 Kilocycles, 356.9 Meters—Canadian Wave:

850 Kilocycles, 352.7 Meters:
KWKH, WWL, KFQZ

860 Kilocycles, 348.6 Meters:
WBOQ, WABC

870 Kilocycles, 344.6 Meters:
WLS, WENR, WBCN

880 Kilocycles, 340.7 Meters—Canadian Shared:
WQAN, WGBI, WCOC, KLX, KPOF, KFKA

890 Kilocycles, 336.9 Meters—Canadian Shared:
WJAR, WMMN, WMAZ, WGST, KGJF, WILL, KUSD, KFNF, WKAQ

900 Kilocycles, 331.1 Meters:
WFBL, WMAK, WKY, WFLA, WSUN, WLBL, KHJ, KSEI, KGBU

910 Kilocycles, 329.5 Meters—Canadian Wave:

920 Kilocycles, 325.9 Meters:
WWJ, KPRC, WAAF, KOMO

930 Kilocycles, 322.4 Meters—Canadian Shared:
WIBG, WDBJ, WBRC, KGBZ, KMA, KFWM, KFWI

940 Kilocycles, 319 Meters:
WCSH, WFIW, KOIN, KGU, KFEL, KFXF

950 Kilocycles, 315.6 Meters:
WRC, KMBC, KLD, WHB, KFVB, KPSN, KGHL

960 Kilocycles, 312.3 Meters—Canadian Wave:

970 Kilocycles, 309.1 Meters:
WCFL, KJR

980 Kilocycles, 305.9 Meters:
KDKA

990 Kilocycles, 302.8 Meters:
WBZ, WBZA

1000 Kilocycles, 299.8 Meters:
WHO, WOC, KGFH

1010 Kilocycles, 296.9 Meters—Canadian Shared:
WQAO, WPAP, WHN, WRNY, KGGF, WNAD, KQW, WSIS

1020 Kilocycles, 293.9 Meters:
KYW, KFK, KYWA, WRAX

1030 Kilocycles, 291.1 Meters—Canadian Wave:

1040 Kilocycles, 288.3 Meters:
WKEN, WKAR, WFAA, KRLD

1050 Kilocycles, 285.5 Meters:
KNX

1060 Kilocycles, 282.8 Meters:
WBAL, WJAG, KWJJ

1070 Kilocycles, 280.2 Meters:
WAAT, WTAM, WEAR, WCAZ, WDJ

1080 Kilocycles, 277.6 Meters:
WBT, WCB, WMBI

1090 Kilocycles, 275.1 Meters:
KMOX, KFQA

1100 Kilocycles, 272.6 Meters:
WPG, WLWL, KJBS

1110 Kilocycles, 270.1 Meters:
WRVA, KSOO

1120 Kilocycles, 267.7 Meters—Canadian Shared:
WCOA, WTAW, KUT, WISN, WHAD, KFSG, KMIC, KRSC, WDEL

1130 Kilocycles, 265.3 Meters:
WV, KFKB, KSL

1140 Kilocycles, 263.0 Meters:
WAPI, KVOO

1150 Kilocycles, 260.7 Meters:
WHAM, KGDM

1160 Kilocycles, 258.5 Meters:
WVVA, WOWO

1170 Kilocycles, 256.3 Meters:
WCAU, KTNT, KEJK

1180 Kilocycles, 254.1 Meters:
WGBS, WJJD, KEX, KOB

1190 Kilocycles, 252.0 Meters:
WICC, WOAI

1200 Kilocycles, 249.9 Meters: Canadian Shared:
WABI, WCAX, WNBX, WEPS, WKRE, WIBX, WFBE, WHBC, WLAP, WLBG, WNBQ, WPRC, WKJC, WNBW, WABZ, WJBW, WBBY, WBBZ, WFBC, WRBL, KGCU, WJBC, WJBL, WVAE, WRAF, WMT, KFJB, WCAT, KGDY, WMAV, KFWF, KFZZ, KGDE, KGFK, WCLO, WHBY, KFWC, KPPC, KXO, KMI, KSMR, KWG, KGEW, KFHA, KVOS, KGY

1210 Kilocycles, 247.8 Meters—Canadian Shared:
WJBI, WGBB, WINR, WCOH, WOCL, WLCL, WPAW, WDFW, WLSI, WMAN, WLBW, WEBE, WBAX, WJBU, WMBG, WSIX, WRBU, WBY, WMBR, WRBQ, WGM, WEA, KDLR, KGG, KFOR, WHBU, KFVS, WEBQ, WSBC, WCRW, WEDC, WCB, WTAX, HBF, WIBA, WOMT, KPQ, KPCB

1220 Kilocycles, 245.6 Meters:
WCAD, WCAE, WREN, KFBU

1230 Kilocycles, 243.8 Meters:
WNAC, WBIS, WPSC, WSBT, WFBM, KYA, KFIO, KFQD

1240 Kilocycles, 241.8 Meters:
WGHP, KFQB, WJAD, WQAM, WIOD, WRBC, KTAT

1250 Kilocycles, 239.9 Meters:
WGCP, WODA, WAAM, WLB, WGMS, WRRM, KFMX, WCAL, KXY, KIDO, KFOX

1260 Kilocycles, 238.0 Meters:
WLBW, WJAX, KWVG, KRGV, KOIL

1270 Kilocycles, 236.1 Meters:
WEAL, WASH, WOOD, WDSU, KWLC, KGCA, KTW, KOL, KFUM, WFB

1280 Kilocycles, 234.2 Meters:
WCAM, WCAP, WOAX, WDDO, WRR, WDAY, WEBC

1290 Kilocycles, 232.4 Meters:
WNBZ, WJAS, KTS, KFUL, KLCN, KDYL

1300 Kilocycles, 230.6 Meters:
WBRR, WHAP, WEVD, WHAZ, KFH, WIBW, KGEF, KTBI, KFJR, KTB

1310 Kilocycles, 228.9 Meters:
WKAV, WEBR, WSMD, WNBH, WOL, WGH, WRK, WAGM, WDF, WNAT, WFKD, WHBP, WFBC, WRAW, WGAL, WSAJ, WBRE, WMBL, WKBC, KGHC, WGBT, WNB, KRMD, KGCH, KFPM, WDAH, KGFI, KFPL, KFJR, WKBS, WLBO, WEHS, WCLS, WKBB, WKBI, WHFC, KWCR, KFJY, KFGO, WBOV, WJAK, WLBC, WIBU, KFBC, KFCB, KFIU, KGEZ, KFUP, KFXJ, KFBK, KFCB, KFIU, KGEZ, KFUP, KFXJ, KMED

1320 Kilocycles, 227.1 Meters:
WADC, WSMB, KGIO, KGIF, KGHB

1330 Kilocycles, 225.4 Meters:
WDRC, WTAQ, KSCJ

1340 Kilocycles, 223.7 Meters:
WSPD, KFPW, KMO, KVI

1350 Kilocycles, 222.1 Meters:
WBNY, WMSG, WCDA, WKBO, KWK

1360 Kilocycles, 220.4 Meters:
WBET, WMAF, WQBC, WJKS, WGES, KFB, KGIR, KGB

1370 Kilocycles, 218.8 Meters:
WMOB, WSVS, WCBM, WBBL, WHBD, WJBK, WIBI, WRAK, WEL, WJBO, WHBO, WRBT, KGFG, KGCB, KGCI, KGRC, KFJZ, KGKL, KFLX, WFB, KGDA, KZM, KRE, KGER, KFBL, KKP, KFEC, KWKC, KGBX, WRJN, KGAR, KFUR, KOH, KVL, KFJL, KGFL, KGGM, WHDF, KOOS, WGL, KFJM

1380 Kilocycles, 217.3 Meters:
WCSO, KQV, KSO, WKBH

1390 Kilocycles, 215.7 Meters:
WHK, KLRA, KUOA, KOW, KWSC, KFPY, WDG, WHDI

1400 Kilocycles, 214.2 Meters:
WCGU, WSGH, WSDA, WLTH, WBBC, WBAA, WCMA, WKBF

1410 Kilocycles, 212.6 Meters:
KGRS, WDAG, KPLV, WHBL, WBCM

1420 Kilocycles, 211.1 Meters:
WLBH, WHPP, WMRJ, WLEX, WTBO, WSSH, WSRQ, WBR, WAAD, WEDH, WMB, WKBP, WQZ, KGF, KOCW, KTAP, KTUE, KFYO, KICK, WIAS, KGCN, WLBF, WMBH, KGF, KFZ, KFXY, KGFJ, KFQU, KGTT, KFSD, KGHD, KGXC, KFI, KORE, KFWQ, KXRO, WIL, KGIW, KGKX, WHDL

1430 Kilocycles, 209.7 Meters:
WBRL, WMBS, WCAH, WGBC, WNBR, WBAK

1440 Kilocycles, 208.2 Meters:
WHEC, WABO, WOKO, WCBA, WNRC, WTAD, WMBD, KLS, WSN

1450 Kilocycles, 206.8 Meters:
WBMS, WNJ, WBS, WKBO, WSAR, WJAY, WFJC, KSBA, WTFI

1460 Kilocycles, 205.4 Meters:
WJSV, KSTP

1470 Kilocycles, 204.0 Meters:
WKBW, KFJF, WRUF, KGA

1480 Kilocycles, 202.6 Meters:
WJAZ, WHT, WORD

1490 Kilocycles, 201.6 Meters:
WBAW, WLAC, WFBL, KPWF

1500 Kilocycles, 199.9 Meters:
WMA, WLOE, WMES, WNEF, WMBQ, WLBZ, WCLB, WWRL, WAFD, WKBZ, WMP, WMBJ, WALK, WHBW, WPSW, WVBZ, KPHL, WRBJ, KGKB, KGDR, KGHX, WKBV, KPJM, KWBS, KWTC, KDB, KUJ, WILM.



Since radios became musical instruments

Transformers must meet new, exacting standards

Now, we know it was but a semblance of a farflung voice that thrilled us in those early years of radio reception. Today, the novelty is gone—radio must be true and faithful in tone or it is not pleasing—it will not sell!

The wise custom builder or manufacturer knows that he must meet competition in the "audio end" of his product. Distance, selectivity—Yes. But above all—TONE!

Better tubes and better speakers play important parts in faithful reproduction—but transformers are sometimes neglected.

And the science of transformer building is a specialty in itself—it is a field too wide and varied to be handled successfully as a mere step in receiver manufacture. It is best left to an organization like "Sangamo" whose experience, research and precision manufacturing facilities guarantee the result.

Within the Sangamo Audio Line is found specially designed equipment to match specific types of tubes and speakers



SANGAMO ELECTRIC CO.

SPRINGFIELD, ILLINOIS, U. S. A.

Manufacturers of Precision Electrical Apparatus for 30 Years



SEE REVERSE
SIDE

SANGAMO Condensers

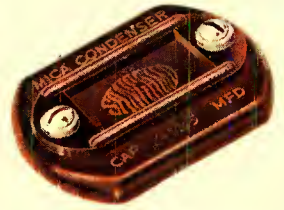

No item can cost so little and cause so much trouble in a receiver as a fixed condenser. This fact is especially appreciated by the manufacturer with an eye to the service problem. Likewise experience has shown that a fixed condenser is not necessarily a good condenser just because it is moulded in Bakelite.

The immunity to thermal changes and to mechanical damage rendered by the Bakelite enclosure is supplemented in Sangamo Condensers by accurate rating and sound construction of the mica condenser within the Bakelite casting.

The standard line of Sangamo Fixed Condensers leave the factory tested to maximum variation of 10%.

NEW!

Condensers for
Manufacturers

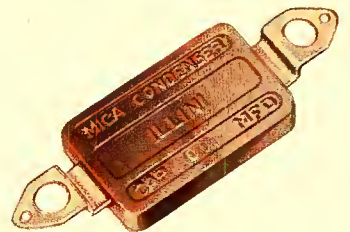

While the Sangamo Condensers shown at the top of the page have always been popular with manufacturers, there has been a demand for condensers of the same quality of a size and shape more suitable for factory set design and production. For manufacturers use only we have designed the Sangamo "Illini." The connecting lugs may be bent to any position required without impairing the condenser.

Prices on request

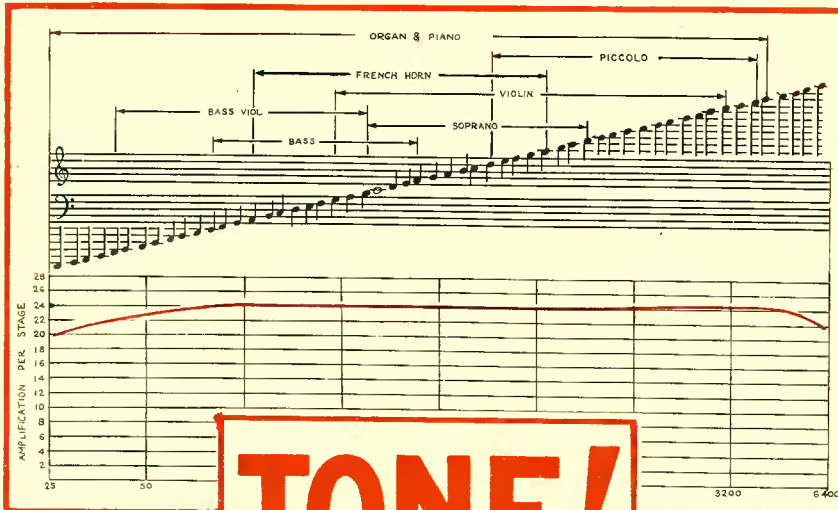

TONE!

Curve of Type "A" of Sangamo Straight Audio Transformer showing uniformity of amplification at all audible frequencies.

BETTER Transformers for every radio need!

"X" Line Transformers

- Type AX straight audio amplification list price, \$6.00
- Type BX Push-pull Input unit list price, 6.50
- Type CX-171 Push-pull Output Transformer, for 171 or 250 power output tubes for cone speaker list price, 6.50
- Type DX, same as CX except for 210 and 112 power tubes list price, 6.50
- Type HX Push-pull Output for 171 or 250 Power Output tubes to match the impedance of moving coil of Dynamic loud speakers . . . list price, 6.50
- Type GX, same as HX except for 210 and 112 power tubes list price, 6.50
- Type E output choke to match impedance of the various type power tubes . . . list price, 5.00

"A" Line Transformers

- Similar to X Line but with special core metal to give greater amplification at low frequencies*
- Type A straight audio amplification list price, \$10.00
- Type B Push-pull Input Transformer for all tubes, list price, 12.00
- Type C-171 Push-pull Output, for 171 or 250 type power tubes with cone speaker . . . 12.00
- Type D-210, same as C except for 210 and 112 power tubes 12.00
- Type H-171, Push-pull Output for 171 or 250 power tubes for Dynamic Speaker list price, 12.00
- Type G-210, same as type H except for 210 and 112 tubes 12.00
- Type F Plate Impedance for use as a choke to prevent oscillation and for impedance coupled amplifiers, list price, 5.00

PIN THIS TO YOUR LETTERHEAD AND MAIL

SANGAMO ELECTRIC CO., Springfield, Illinois, U. S. A. Dept. 34

(For manufacturers) I am interested in engineering data regarding your transformers and condensers.

(For dealers) Please send data on Sangamo Condensers.

(For set builders) Please send circulars describing your apparatus and latest audio hook-ups.



"Found the Short Cut to Success in Radio

through this amazing home laboratory method!"

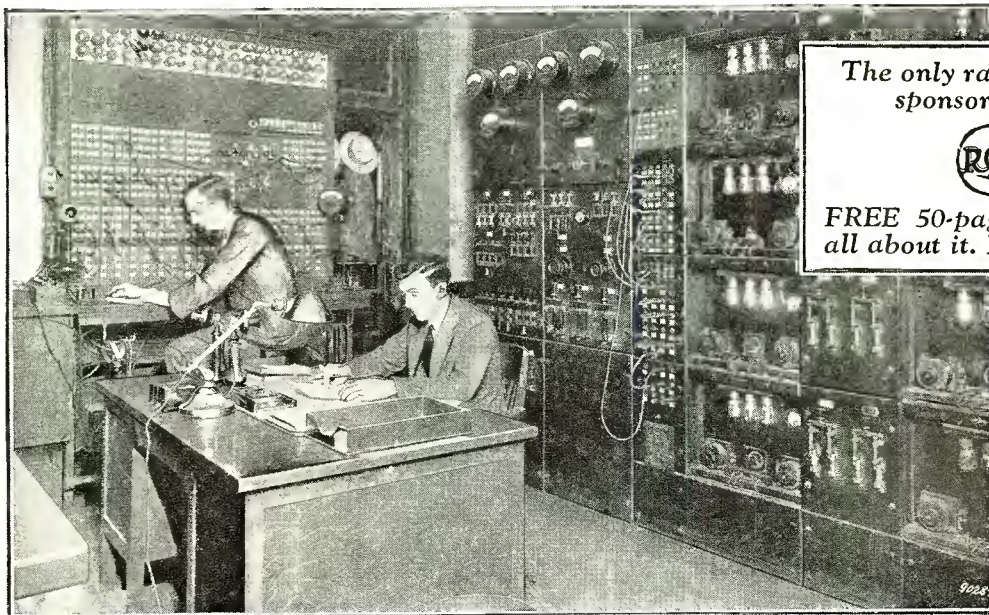

The only radio training sponsored by



FREE 50-page book tells all about it. Mail coupon.

By Frank Halloran

I GOT hungry to get into Radio when I learned about the big money it was bringing my next door neighbor.

He was only twenty-eight years old, but his income was over four times as much as I was getting. He owned a fine car, dressed in expensive clothes, took weekends off to go hunting and fishing, and was one of the most popular fellows in town.

"Charlie," I asked him one day, "how did you become a radio expert?"

"A cinch," he smiled. "I took it up in my spare time at home."

"What?" I asked in surprise, "you actually took a radio course by mail?"

"No," he shot back. "Not just a mail order course, but the only technical home-laboratory training conducted under the auspices of the Radio Corporation of America! Believe me, this 'big-league' organization not only knows what's what in radio, but it knows how to teach it!"

A Great Piece of Luck

Taking Charlie's advice was the luckiest thing I've ever done. It's bringing me more money in a week than I've often earned in a month!

I never dreamed that learning radio at home was so easy and so fascinating. From

the very first lesson to the last I was thrilled! Each subject was explained in simple word and picture form . . . and written in such an interesting style that I was carried along like a novel!

I didn't know the first thing about radio when I started, yet before many months were over I was able to solve many of the problems which now help me command big money. The lessons took me step by step through trouble-finding and repairing . . . through ship and shore and broadcasting apparatus operation and construction . . . through photoradiograms, television and beam transmission . . . through radio salesmanship, store operation and executive work.

Success—In Spare Time!

I didn't have to give up my regular job. I learned at home during my spare time. And I actually learned by doing! With the course, I received an outlay of the finest standard apparatus with which I was able to build radio circuits and sets of almost every description . . . yet this expensive apparatus cost me absolutely nothing extra!

Even before I had completed the course I was able to earn good money doing odd radio jobs. And it wasn't long after that I was able to give up my regular work and branch out for myself as a full-fledged expert in work that is fun and extremely profitable!

Today, my income is more than doubled . . . and I've only just started! I'm certainly happy that I found this short cut to success!"

Read This Thrilling FREE Book

Frank Halloran's wonderful success is just another typical example of the success which the Radio Institute is bringing to hundreds of men everywhere through its wonderful home-laboratory training . . . the only official radio training based on the inside knowledge of radio developed in the great experimental laboratories of the Radio Corporation of America.

There is an amazing opportunity for you in Radio. Manufacturers, dealers, broadcasting stations, ships . . . all are calling for trained radio experts. The pay is big—the opportunities are limitless—the work is thrilling! Find out all about it. The Institute has prepared an interesting, illustrated booklet telling you all you want to know about this vast industry and about the remarkable home study-course that can fit you for a brilliant radio career. Just mail the coupon below and claim your copy of this valuable booklet . . . it's absolutely free! Radio Institute of America, Dept. CB-3, 326 Broadway, New York



Mail this coupon

Radio Institute of America
Dept. CB-3, 326 Broadway, New York, N.Y.

Gentlemen: Please send me your FREE 50-page book which tells all about the great opportunities in Radio and about your famous home-laboratory method of guaranteed radio instruction sponsored by the Radio Corporation of America.

Name

Address

CANADIAN STATIONS

Call	Station	Wave	Power	Call	Station	Wave	Power
PRINCE EDWARD ISLAND							
CFCY	Island Radio Co., Charlottetown.....	312.3	100	CKCD	Daily Province, Vancouver.....	410.7	50
CHCK	W. E. Burke, Charlottetown.....	312.3	30	CHWK	Chilliwack Broadcast Co., Chilliwack.....	247.8	5
CHGS	R. T. Holman, Ltd., Summerside.....	267.7	25	CKOR	G. C. Chandler, Sea Island.....	291.1	50
QUEBEC							
CFCF	Canadian Marconi Co., Montreal.....	410.7	650	CKMO	United Church of Canada, Vancouver.....	410.7	50
CHRC	E. Fontaine, Quebec.....	340.7	5	CKWX	Sprott-Shaw Radio, Vancouver.....	410.7	50
CHYC	Northern Electric Co., Ltd., Montreal.....	410.7	750	CNRY	A. Holstead & Wm. Hanlon, Vancouver.....	410.7	100
CKAC	La Presse Publishing Co., Montreal.....	410.7	1200		Canadian National Railways, Vancouver.....	291.1	500
CKCI	Le "Soleil," Ltd., Quebec.....	340.7	22 1/2	MANITOBA			
CKCV	G. A. Vandry, Quebec.....	340.7	50	CKY	Manitoba Telephone System, Winnipeg.....	384.4	500
CKSH	City of St. Hyacinthe, St. Hyacinthe.....	296.9	50	CNRY	Canadian National Railways, Winnipeg.....	384.4	500
CNRM	Canadian National Railways, Montreal.....	410.7	1650	NEW BRUNSWICK			
CNRO	Canadian National Railways, Quebec.....	340.7	50	CFBO	C. A. Munro, Ltd., St. John.....	336.9	50
SASKATCHEWAN							
CFCQ	The Electric Shop, Saskatoon.....	329.5	500	CFNR	James S. Neill & Sons, Ltd., Fredericton.....	247.8	100
CHWC	R. H. Williams & Sons, Regina.....	312.3	15	CNRA	Canadian National Railways, Moncton.....	475.9	500
CJBR	Saskatchewan Co-op. Wheat Producers, Ltd., Regina.....	312.3	500	NOVA SCOTIA			
CJGX	Winnipeg Grain Exchange, Yorkton.....	475.9	500	CHNS	Northern Electric Co., Ltd., Halifax.....	322.4	100
CJHS	Radio Service, Ltd., Saskatoon.....	329.5	250	CHNS	Halifax Herald, Halifax.....	322.4	500
CJEM	James Richardson & Sons, Ltd., Moose Jaw.....	296.9	500	ONTARIO			
CJRW	James Richardson & Sons, Ltd., Fleming.....	296.9	500	CFCA	Star Publishing & Printing Co., Toronto.....	356.9	500
CNRR	Canadian National Railways, Regina.....	312.3	500	CFCH	Abitibi Paper & Paper Co., Ltd., Iroquois Falls.....	499.7	250
CKCK	Leader Publishing Co., Ltd., Regina.....	312.3	500	CFCL	Radio Association of Kingston, Prescott.....	296.9	50
CNRS	Canadian National Railways, Saskatoon.....	329.5	500	CFMC	Monarch Battery Co., Kingston.....	267.7	20
ALBERTA							
CFAC	Calgary Herald, Calgary.....	434.5	500	CFRE	Standard Radio Mfg. Corp., Ltd., King.....	312.3	1000
CKCN	W. W. Grant, Ltd., Calgary.....	434.5	1800	CFRC	Queens University, Kingston.....	267.7	500
CHCA	Albertan Publishing Co., Calgary.....	434.5	250	CHCS	Hawilton Spectator, Hamilton.....	340.7	10
CJCT	Radio Service & Repair Shop, Calgary.....	434.5	250	CHML	Maple Leaf Radio Co., Ltd., Mt. Hamilton.....	340.7	50
CHCT	G. F. Tull & Arden, Ltd., Red Deer.....	356.9	1000	CHNC	Toronto Radio Research Society, Toronto.....	516.9	500
CKLC	Alberta Pacific Grain Co., Red Deer.....	356.9	1000	CKNC	Canadian National Carbon Co., Toronto.....	516.9	500
CHMA	Christian & Missionary Alliance, Edmonton.....	516.9	250	CJBC	Jarvis Street Baptist Church, Toronto.....	516.9	500
CJCA	Edmonton Journal, Ltd., Edmonton.....	516.9	500	CJGC	Free Press Printing Co., Ltd., London.....	329.5	500
CJOC	J. E. Palmer, Lethbridge.....	267.7	50	CJSC	Evening Telegram, Toronto.....	516.9	500
CKTA	University of Alberta, Edmonton.....	516.9	500	CKCL	Dominion Battery Co., Toronto.....	516.9	500
CNRC	Canadian National Railways, Calgary.....	434.5	500	CKCO	Ottawa Radic Assn., Ottawa.....	434.5	100
CNRE	Canadian National Railways, Edmonton.....	516.9	500	CKCR	John Patterson, Brantford.....	296.9	50
BRITISH COLUMBIA							
CFCT	Victoria Broadcasting Assn., Victoria.....	475.9	500	CKGW	Gooderham & Worts, Bowmanville.....	312.3	5000
CFJC	N. S. Lalgleish & Sons, Kamloops.....	267.7	15	CKMC	R. L. MacAdam, Cobalt.....	247.8	15
CHLS	W. G. Hassell, Vancouver.....	410.7	50	CKOG	Wenworth Radio & Auto Supply Co., Ltd., Hamilton.....	340.7	100

SHORT WAVE PHONE AND TELEGRAPH STATIONS

109.0	2XK, Schenectady, N. Y.	42.95	KDKA, East Pittsburgh, Pa.	26.78	KDKA, East Pittsburgh, Penn.
107.1	KIU, Guadalupe, Calif.	40.0	6NBR-KFWB, Los Angeles, Calif.	26.0	KDKA, East Pittsburgh, Pa.
105.0	6NBR-KFWB, Los Angeles, Calif.	37.24	WCFL, Chicago, Ill.	22.8	WOWO, Ft. Wayne, Ind. (phone)
100.9	2XI, Schenectady, N. Y.	35.0	WGY, Schenectady, N. Y.	21.96	WVO, Schenectady, N. Y.
85.4	2XAO-WOR, Newark, N. J.	35.0	2XI, Schenectady, N. Y.	20.0	2XAW, Schenectady, N. Y.
63.66	KDKA, East Pittsburgh, Pa.	31.48	2XAF-WGY, Schenectady, N. Y.	19.56	2XAD, Schenectady, N. Y.
58.75	KDKA, East Pittsburgh, Pa.	30.91	2XAL-WRNY, Coyotesville, N. J.	18.3	WBQ, Schenectady, N. Y.
58.5	2XE, Richmond Hill, N. Y.	30.0	2XI, Schenectady, N. Y.	15.0	2XAW, Schenectady, N. Y.
52.02	8XAL-WLW, Harrison, Ohio.				

SHORT WAVE TELEVISION STATIONS

Call	K. C.	Meters	Owner	Aper- tures	Call	K. C.	Meters	Owner	Aper- tures
4XA	2400-2500	125-200	WREC, Inc., Memphis, Tenn.....	48	3XK	4900-5000	61.22-60.00	Chicago Federation of Labor, Chicago.....	48
2XBV	4500-4600	66.67-65.22	R. C. A., New York City, N. Y.....		3XK	6420	46.72	C. Francis Jenkins, Washington, D. C.....	48
6XC	4500-4600	66.67-65.22	Robert B. Parrish, Los Angeles, Calif.....		2XAL	9710	30.91	Radio News, New York City, N. Y.....	48
2XBES	4600-4700	65.22-63.83	R. C. A., New York City, N. Y.....		WXO	13,660	21.96	General Electric Co., Schenectady, N. Y.....	
8XAV	4700-4800	63.83-62.50	Westinghouse Elec. Co., Pittsburgh, Pa.....		WCFL	4847-4959	61.9-60.50	R. C. A., New York City, N. Y.....	
2XBU	4800-4900	62.50-61.22	H. E. Smith, Beacon, N. Y.....		2XBV	15100-15200	19.87-19.74	Westinghouse Elec. Co., Pittsburgh, Pa.....	
1XAX	4800-4900	62.50-61.22	J. S. Dodge, Lexington, Mass.....	48	8XAV	15100-15200	19.87-19.74		

FOREIGN BROADCAST STATIONS

(Much of the data here shown is supplied by the Bureau of Foreign and Domestic Commerce Division of the Department of Commerce)

ARGENTINA			AUSTRIA			CHILE		
Call	Wave	Station	Call	Wave	Station	Call	Wave	Station
LOZ	330	Buenos Aires	Graz	365.8		CMAI	345	Concepcion
LOS	291.2	Buenos Aires	Innsbruck	294.1		CMAC	360	Sanitago
LOH	210	Buenos Aires	Klagenfurt	272.7		CMAD	320	Santiago
LOV	344.8	Buenos Aires	Linz	254.2		CMAE	280	Santiago
LOY	315.5	Buenos Aires	Vienna	577		CMAT	550	Tacna
LOX	380	Buenos Aires	Vienna	517.2		CMAK	245	Temuco
LOQ	261	Buenos Aires	Vienna	22.2		CHINA		
LOO	252	Buenos Aires	Vienna	74		COHB	435	Harbin
LOJ	270	Buenos Aires	Vienna	37		COMK	425	Mukden
LOI	303	Buenos Aires	AFRICA (NORTH AND EAST)			KRC	338	Shanghai
LOT	400	Buenos Aires	Algiers	310		COTN	480	Tientsin
LOL	236	Buenos Aires	Cairo	255		GEC	280	Tientsin
D3	253.3	Buenos Aires	Carthage	250		VPS3	800	Victoria
R2	275	Buenos Aires	Casablanca	51		CHOSEN		
H5	275	Cordova	Casablanca	42.8		JODK	357	Seoul
H6	250	Cordova	Narohi	90		CUBA		
LOP	425	La Plata	Rabat	416		6EV	250	Caibarien
LOU	380	Mendoza	Tunis	1450		7AZ	225	Camaguey
M6	348	Mendoza	AFRICA (SOUTH)			7EV	190	Camaguey
F2	270	Rosaria	Capetown	372		7GT	195	Camaguey
F1	279	Santa Fe	JB	398		7LO	230	Camaguey
AUSTRALIA			JB	443.5		6YR	200	Camaguey
5CL	395	Adelaide	Pretoria	323		8YR	180	Camaguey
5DN	313	Adelaide	BELGIUM			81C	300	Cañey
4QG	385	Brisbane	Antwerp	265.5		7BY	285	Ciego de Avila
4CM	278	Brisbane	Brussels	512		7FU	230	Ciego de Avila
4MB	337	Brisbane	Ghent	275		7HF	192	Ciego de Avila
7ZL	325	Melbourne	Liege	205		7IR	193	Ciego de Avila
3AR	484	Melbourne	Liege	294.1		6BY	260	Cienfuegos
3LO	32	Melbourne	Luxembourg	217.4		6GQ	275	Cienfuegos
31O	371	Melbourne	BOLIVIA			6KC	240	Cienfuegos
31Z	319	Melbourne	La Paz	175		6EV	360	Colon
3WR	303	Melbourne	La Paz	300		7SR	350	Ella
3EO	286	Mildura	BRAZIL			1AZ	275	Guantanamo
2HD	288	Newcastle	SQAD	445		2LC	303	Havana
2UW	263	Northbridge	SQAF	340		CMC	357	Havana
6WF	1250	Perth	SQAJ	380		2AB	200	Havana
6AG	32.9	Perth	SQAK	310		2BB	250	Havana
6NM	323	Rockhampton	SQAL	350		2CC	350	Havana
2FC	28.5	Sydney	SQAM	320		2CT	200	Havana
2KY	280	Sydney	SQAN	260		2CF	192	Havana
2FC	442	Sydney	SQAO	400		2MA	215	Havana
2BL	353	Sydney	SQAP	280		2MG	265	Havana
2BL	32.5	Sydney	SQAR	225.4		2MU	350	Havana
2ME	28.5	Sydney	SQAS	35		2OK	257	Havana
2BP	326	Sydney	SQAT	425		2OI	315	Havana
2CB	297	Sydney	SQAU	125		2RW	270	Havana
2TF	462	Sydney				2UF	275	Havana
2VA	294	Toowoomba						

Call	Wave
2XX	Havana 225
4RG	Havana 200
2FG	Heshey 200
2JF	Maiana 245
2JL	Maiana 294
5DW	Manzas 270
6HS	Sagua la Grande 260
6KP	Saici Spiritus 195
8HS	Sa tiago 200
8DY	Sa tiago 250
8FU	Sa tiago 225
8IR	Sa tiago 190
8JQ	Sa tiago 130
6XJ	Tinnuc 278
6KW	Tinnuc 340
CZECHOSLOVAKIA	
OKR	Bra tislava 300
OKB	Bra tyn 432
	Ko sice 263
	Ko nce 1870
OKP	Pr a g u e 348.9
DENMARK	
D7RL	Copenha gen 84.25
D7MK	Copenha gen 32.05
	Copenha gen 337.4
	Ka undborg 1153
	It y a n g 1150
	Sor o 1153.8
ESTONIA	
	Ta li n 408
	Ta li n n 1200
FINLAND	
	Bj r neborg 254.2
	He si ngfors 500
	He si ngfors 375
	He si ngfors 240
	Ja cobstad 275.2
	La ti tis 1522.8
	La ti tis 318
	Mi eli 566
	Ta n n e r f o r s 400
	U l a b o r g 250
	V i l o r g 240
FRANCE	
2BD	Ag e n 297
	Ag e n 30.75
	Be z i e r s 158
	Bor deaux 258
PTT	Bor deaux 200
	Ca n n o y 416
	Cr e n o l e 246
	Di j o n 285
	Li l l e 264
	Ly o n s 291
YR	Ly o n s 40.2
PTT	Ly o n s 480
	Mi r s e i l l e s 303
	Mo n t e d e M a r z a n 390
	M o n t p e l i e r 238
	N a n c y 15.5
	N i m e s 240
FSAV	N e g e n t s u r S e i n e 80
	Pa r i s 1750
	Pa r i s 308
FL	Pa r i s 2650
FL	Pa r i s 1485
CFR	Pa r i s 1750
PTT	Pa r i s 438
	Pa r i s 350
	Pa r i s 340.9
FL	Pa r i s 32
FSGC	Pa r i s 61
	Pa r i s 37
	R e m e s 280
	S t a s b o u r g 222.2
PTT	T o u l o u s e 260
	T o u l o u s e 389.6
GERMANY	
	A l e - l a - C h a p e l l e 400
	A n s b u r g 566
	B e r l i n 566
AFT	B e r l i n 1649
	B e r l i n 321
	B e s s l a u 272.7
	B r e m e n 283
	C o l o g n e 272.7
	D a n z i g 67.65
AFK	D o b e r i t z 37.65
AFK	D o b e r i t z 283
	D r t m u n d 275.2
	D r e s d e n 268.8
	E l b e r f e l d 421
	E r f u r t 329.7
	F r a n k f u r t 297
HA	H a m b u r g 392
	K a i s e r l a u t e r n 204.1
	K a s s e l 252.1
	K e l 254.2
	K o n i g s b e r g 303
	L a n g e n b e r g 468.8
	L e i p z i g 365.8
	M u n c h e n 335.7
	M u n i c h 235.7
	M u n s t e r 250
AGJ	N u n e n 56.7
AGC	N u n e n 17.2
	N o r d d e i c h 1829
	N u r e m b e r g 241.9
	S c h a r b e c k 230
	S t e t i n 236.2
	S t u t t g a r t 379.7
AFB	Z e s e n 4000
AFP	Z e s e n 2900
	Z e s e n 1250
GREAT BRITAIN	
2BD	A b e r d e e n 311.2
2BE	E l i f a s t 302.7
5IT	B i r m i n g h a m 326.1
6IM	F o u r n e m o u t h 288.5
2LS	B r a d f o r d 252.1
5WA	C a r d i f f 323.2
2NM	C a t e r h a m 32.5
6SW	C h e l m s f o r d 24
5GE	L a v e n t r y 329.2
5XX	L a v e n t r y 122.5
2DE	L i n c o l n 294.1
2EH	E d i n b u r g 288.5
5SC	G l a s g o w 401.1
6KI	L u l l 294.1
2LS	L e e d s - B r a d f o r d 277.8

Call	Wave
6LV	Liverpool 297
2LO	London 358
2ZY	Manchester 378.3
5NO	Newcastle 243.9
5NG	Nottingham 275.2
5PY	Plymouth 400
6FL	Sheffield 272.7
6ST	Stoke-on-Trent 294.1
5SX	Swansea 294.1
HAITI	
HHK	Port au Prince 361.2
HOLLAND	
	Bloemendaal 566
PCJI	Eindhoven 31.4
PCFF	Haarlem 1100
HDO	Hilversum 1071
	Huisen 340.9
	Huisen 1852
PCLL	Kootwijk 18.4
	Scheveningen 1950
HUNGARY	
MTI	Budapest 554
MT2	Budapest 1050
ICELAND	
	Akureyri 192
	Reykjavik 333.3
INDIA AND CEYLON	
VTR	Bombay 357.1
2AX	Bombay 320
2FY	Bombay 357
VTG	Calcutta 370.4
VPR	Colombo 800
2BR	Madras 400
2IIZ	Rangoon 350
IRISH FREE STATE	
6CK	Cork 400
2RN	Dublin 411
ITALY	
1MI	Milan 549
1NA	Naples 333.3
1RO	Rome 447.8
1IAX	Rome 45
JAPAN	
JHRB	Hirasio 37.5
JOFK	Hiroshima 353
JOJK	Kobe 357
JOGL	Kinamato 380
JOCK	Nagoya 360
JOBK	Osaka 385
JFAK	Taijiah 39.5
JOAK	Tokyo 375
JOIK	Sapporo 361
JOIKK	Sandai 390
JAVA	
JFC	Batavia 220
ANH	Malabar 17
	Surabaya 140
ANE	Vandoeng 31.86
ANE	Vandoeng 15.93
	Vandoeng 310
JUGOSLAVIA	
	Zagreb 309.2
KWANTUNG	
JQAK	Dairen 395
LATVIA	
KCX	Riga 526.3
LITHUANIA	
	Kaunas 2000
MEXICO	
XFF	Chihuahua 325
XES	Ciudad Lerdo 250
XEA	Guadalajara 250
XFC	Jalapa 475
XEY	Merida 548.6
XEX	Mexico City 325
XFX	Mexico City 357
XEN	Mexico City 410
XEB	Mexico City 450
XFG	Mexico City 470
XFI	Mexico City 507
XFA	Mexico City 600-500
XEH	Monterey 311
XEI	Morelia 300
XEF	Oaxaca 265
XEE	Puebla 312
NEW ZEALAND	
1ZB	Auckland 275
1ZQ	Auckland 253
1YA	Auckland 333
3ZC	Christchurch 250
3YA	Christchurch 306
4ZL	Dunedin 252
4ZM	Dunedin 277.8
4YA	Dunedin 463
2ZM	Gisborne 260
4ZB	Otago 300
2ZF	Palmerston 285
3ZA	Wanganui 300
3YA	Wellington 420
NORWAY	
	Aalesund 511
	Bergen 366
LGN	Bergen 30
	Bergen 370.4
	Fredrikstad 434.8
	Notodden 411
	Oslo 461.5
	Porsgrund 509
	Rjukan 447.8
	Stavanger 277.6
	Tronho 500
	Trondhjem 243.9
PERU	
OAX	Lima 360
PHILIPPINES	
KZIB	Manila 260
KZIK	Manila 270.1
KZRM	Manila 413
POLAND	
	Cracow 314
	Kattowitz 416
	Posen 344.8
AXO	Warsaw 1111
	Wilna 435

Call	Wave
PORTUGAL	
PIAA	Lisbon 305
ROUMANIA	
	Bucharest 401.6
SALVADOR	
AQM	Salvador 482
SPAIN	
EAI18	Almeria 320
EAI13	Barcelona 462
EAI1	Barcelona 350
EAI13	Barcelona 277
EAI9	Bilbao 434.8
EAI3	Cadiz 400
EAI5	Cartagena 330
EA15	Las Palmas (Canary Islands) 250
EA15	Las Palmas (Canary Islands) 350
EAM	Madrid 30.7
EAI7	Madrid 434.8
EAI2	Madrid 420
EAI25	Malaga 250
EAI19	Oviedo 280.4
EAI22	Salamanca 405
EAI8	San Sebastian 297
EAI17	Seville 434.8
STRAITS SETTLEMENTS	
ISE	Singapore 330
SWEDEN	
SASE	Boden 1190
SMYB	Boras 230.8
SMXF	Gavle 204.1
SAB8	Goteborg 416.5
SMZK	Falun 315.8
SMIC	Eskilstuna 250
SMSB	Halmstad 215.8
SMYE	Halsingborg 229
	Hamar 555.8
SMSL	Indiksvall 272.7
SMZD	Jonkoping 201.3
	Kalmar 254.2
	Kalmar 52.2
	Karlskrona 196
SMSM	Karlskrona 220.6
SMXG	Karlskrona 238.1
SMTG	Kiruna 202.7
SMTI	Kristinehamn 500
SMI W	Linkoping 400
SMXO	Malmberget 260.9
SASO	Malmo 1380
SASG	Motala 275.2
SMYV	Norjokoping 236.2
SMTI	Orebro 187.5
SMZA	Omskoldsvik 720
SASF	Ostersund 252.1
SMTS	Safie 454.5
SASA	Stockholm 545.6
SASD	Smidsvall 277.8
SMXO	Trollhattan 254.1
SMZP	Udevalla 229
SMSX	Umea 500
SMSX	Uppsala 297
SMISO	Varborg 297
SWITZERLAND	
HD3	Basle 1000
HOOC	Berne 32
HBA	Berne 407
HBI	Geneva 760
HB2	Lausanne 850
HFXD	Zurich 85
H9XD	Zurich 32
HBZ	Zurich 588
TURKEY	
	Angora 1806
	Stamboul 1200
UNION OF SOVIET SOCIALIST REPUBLICS	
RA47	Armarvir 720
RA56	Artemovsk 790
RA26	Astrakhan 700
RA45	Baku 750
RAN	Bogorodsk 750
RA30	Dnepropetrovsk 525
RA39	Gomel 925
RA7	Iranovo-Vosnessensk 800
RA43	Khar'kov 775
RA45	Kiev 475
RA34	Konrsk 575
RA38	Krasnodar 513
RA59	Leningrad 150
RA18	Minsk 860
RA2	Moscow 450
RA4	Moscow 450
RDW	Moscow 1450
RA17	Nalchik 1075
RA77	Nizhni-Novgorod 840
RA40	Odessa 975
RA25	Orenburg 640
RA64	Petrozavodsk 350
RA46	Petrozavodsk 765
RA14	Rostov-on-Don 820
RA22	Samarra 900
RA32	Saratov 420
RA9	Serastopol 800
RA68	Smolensk 330
RA72	Smolensk 150
RA77	Stalino 730
RA20	Stavropol 550
RA15	Sverdlovsk 1050
RA27	Tashkent 715
RA11	Tiflis 300
RA21	Toms'k 470
RA44	Tver 690
RA51	Ulyanovsk 500
RA16	Vel' Ust'uk 650
RA17	Vladivostok 480
RA41	Vologda 875
RA12	Vorenezh 950
URUGUAY	
CWOA	Montevideo 428.4
CWOF	Montevideo 300
CWOG	Montevideo 280
CWOK	Montevideo 300
CWOL	Montevideo 260
CWOM	Montevideo 272
CWON	Montevideo 265.5
CWOO	Montevideo 256.5
CWOP	Montevideo 294
CWOS	Montevideo 350
CWOI	Salta 272
CWOJ	Salta 250
VENEZUELA	
AYRE	Caracas 375

KC	Meters	STATIONS	DIALS		KC	Meters	STATIONS	DIALS	
			1	2				1	2
1500	199.9				1020	293.9			
1490	201.2				1010	296.9			
1480	202.6				1000	299.8			
1470	204.0				990	302.8			
1460	205.4				980	305.9			
1450	206.8				970	309.1			
1440	208.2				960	312.3			
1430	209.7				950	315.6			
1420	211.1				940	319.0			
1410	212.6				930	322.4			
1400	214.2				920	325.9			
1390	215.7				910	329.5			
1380	217.3				900	333.1			
1370	218.8				890	336.9			
1360	220.4				880	340.7			
1350	222.1				870	344.6			
1340	223.7				860	348.6			
1330	225.4				850	352.7			
1320	227.1				840	356.9			
1310	228.9				830	361.2			
1300	230.6				820	365.6			
1290	232.4				810	370.2			
1280	234.2				800	374.8			
1270	236.1				790	379.5			
1260	238.0				780	384.4			
1250	239.9				770	389.4			
1240	241.8				760	394.5			
1230	243.8				750	399.8			
1220	245.8				740	405.2			
1210	247.8				730	410.7			
1200	249.9				720	416.4			
1190	252.0				710	422.3			
1180	254.1				700	428.3			
1170	256.3				690	434.5			
1160	258.5				680	440.9			
1150	260.7				670	447.5			
1140	263.0				660	454.3			
1130	265.3				650	461.3			
1120	267.7				640	468.5			
1110	270.1				630	475.9			
1100	272.6				620	483.6			
1090	275.1				610	491.5			
1080	277.6				600	499.7			
1070	280.2				590	508.2			
1060	282.8				580	516.9			
1050	285.5				570	526.0			
1040	288.3				560	535.4			
1030	291.1				550	545.1			

Perform that "adenoid operation" on your set . . .

Take out the "adenoids", those inferior transformers which make your set sound as if it were afflicted with a bad case of adenoids . . . Then put in their place, the standard of excellence in Audio Transformers — AmerTran DeLuxe.

Ever hear a child talk before and after an adenoid operation? Well, if you have, you will appreciate the difference AmerTran transformers will make in any set.

AmerTran products are built exclusively for the purpose of achiev-

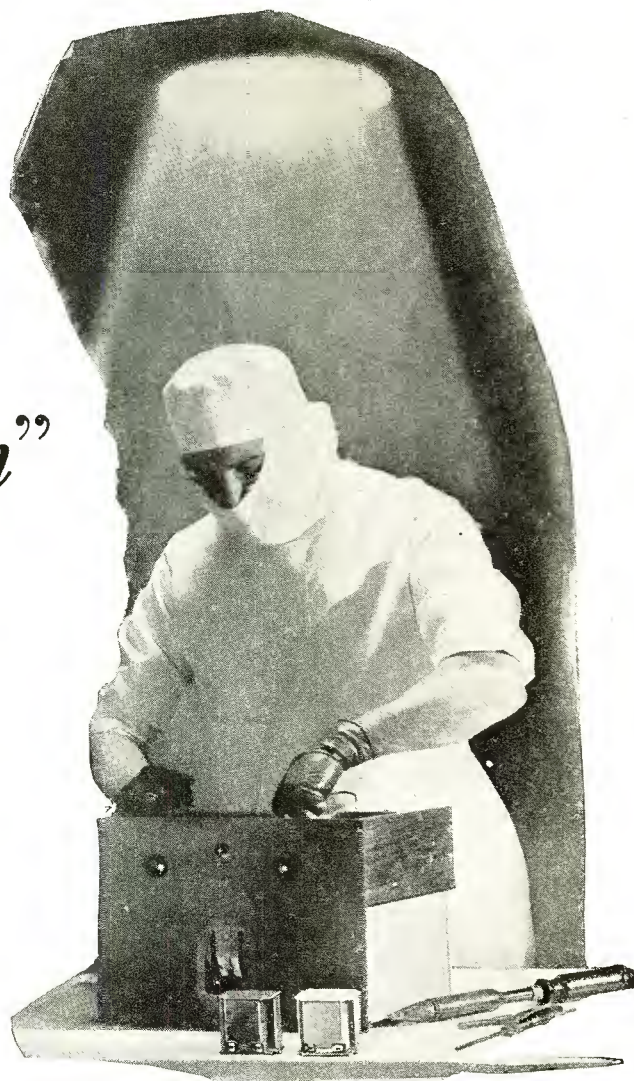

ing realism in tone. It cannot be done cheaply, or haphazardly. AmerTran's 30 odd radio products all play their definite part in producing the finest tone known to Radio.

Why not perform that "adenoid operation" today? See your dealer or write to us. Ask for Bulletin No. 1084.

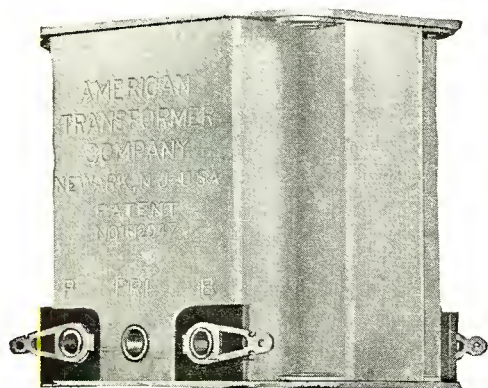

AmerTran DeLuxe—
1st stage turn ratio, 3.
2nd stage turn ratio, 4.
Price each \$10.00.

AMERTRAN

AMERICAN TRANSFORMER COMPANY
Builders of Transformers for more than 29 years
96 Emmet St. Newark, N. J.

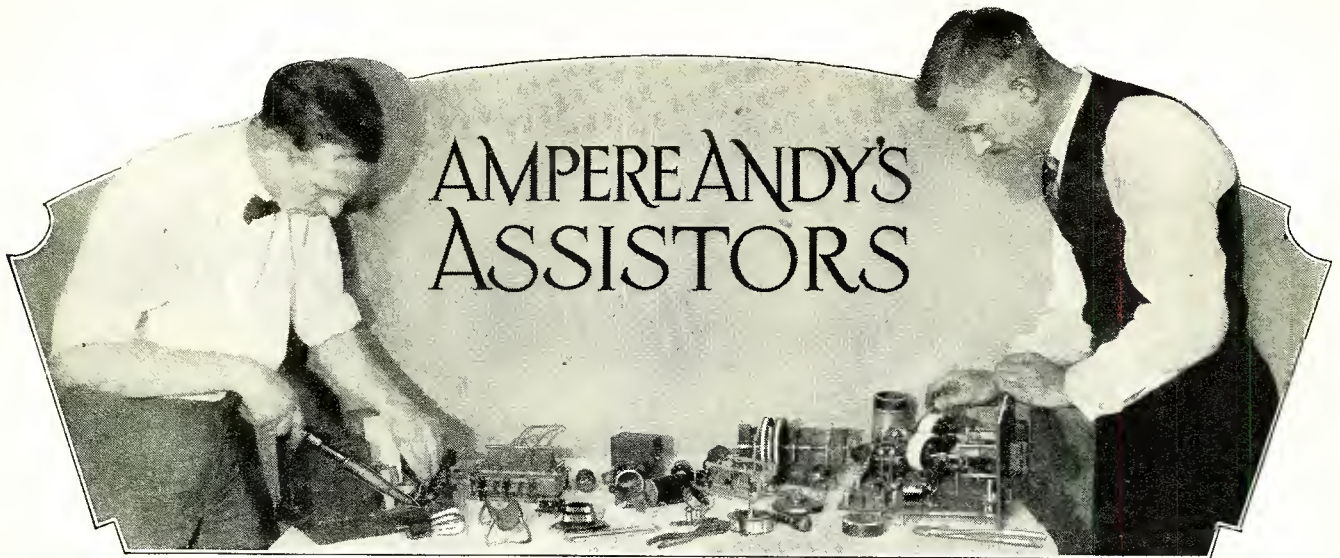

Paper Wad to Level Up Console



Often on account of imperfections in the floor on which a console rests, or perhaps a slight inequality in the length of the legs of the console, this piece of furniture will teeter. In some cases, especially where there is a power pack and other heavy material inside the console, the weight combined with the uneven legs will cause the door of the console either to jam or else swing too freely and stay open. In most of the cases, the difficulty will be that the door of the console will be jammed tight and it will be difficult to open. This condition may be easily remedied by taking several thicknesses of cardboard or folded paper and placing such a wad underneath one of the legs of the console, so as to true it up. When this is done, the weight will be evenly distributed and it will be found that the console door will open without any difficulty

Tighten Loose Terminals

Loose terminals on any piece of radio apparatus are an inconvenience, especially if these terminals are on units designed for sub-panel assembly. Before assembling such units on a sub-panel, it is generally good policy to make sure that all terminals are tight. The photograph shows the manner of holding a terminal bolt with a

pair of pliers, on whose jaws tape has been placed to prevent damaging the thread of the bolt. With another pair of pliers the nut is turned up until it is good and tight. Care should be exer-

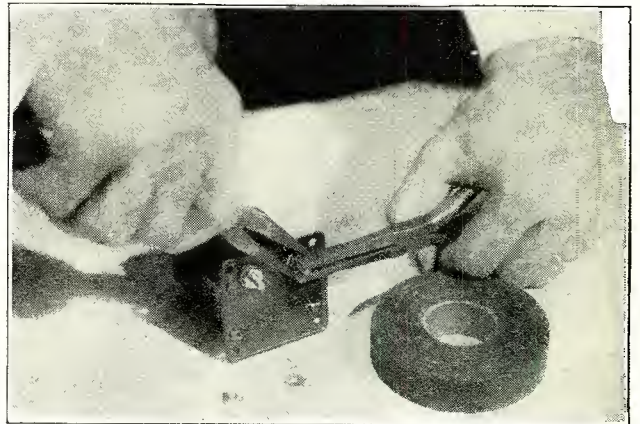

cised in doing this that the bolt itself does not turn, for occasionally when this happens the soldered connection on the inside of the unit will be twisted off.

Preventing Gear Chattering

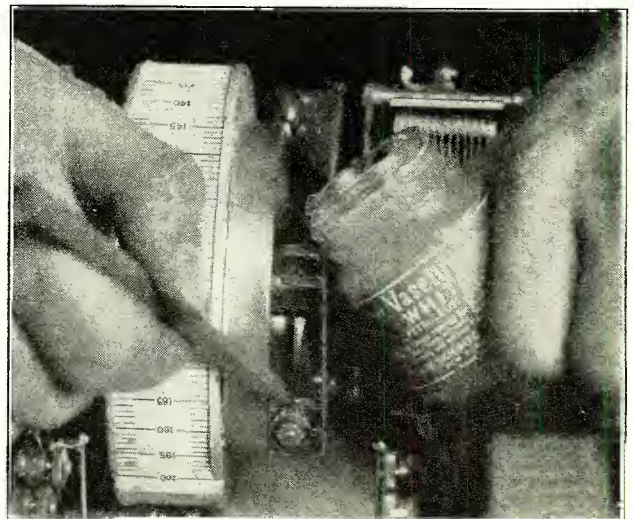

Chattering of dial gears, or even scraping, may be completely eliminated or materially lessened if the scheme shown in the photograph is adopted. Merely daub a generous supply of vaseline on the small gear. On account of the consistency of the vaseline, it will take up any rattle in the cogs, and at the same time contribute considerable smoothness to the operation of the drum dial.

Making Escutcheon Pins Fit

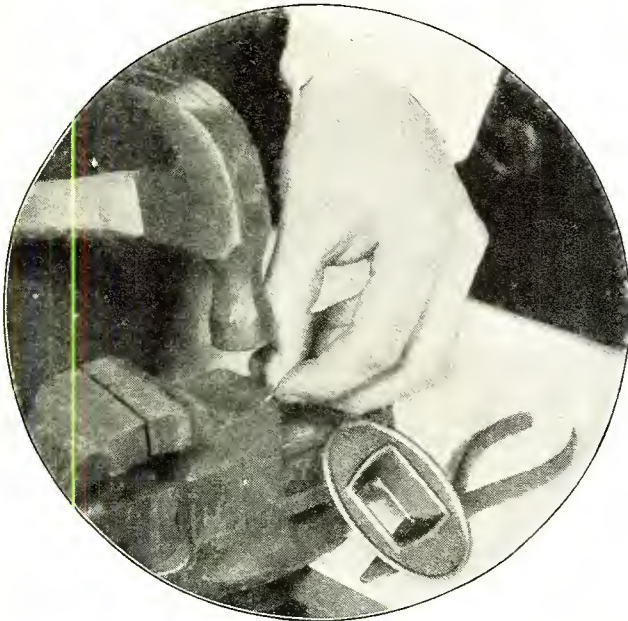

Frequently when holes are drilled in a panel for the escutcheon pins, these pins fit very loosely. In order to make a snug fit, the pin may be flattened as shown in the accompanying illustration, so that when driven in the hole in the panel the flattened section will grip the hole and prevent the pin from being jarred out.



Keep Watch Away from Dynamic

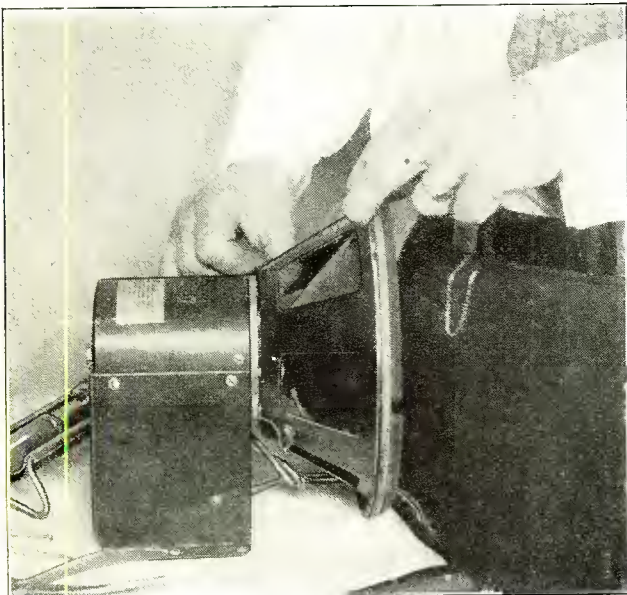

Several of the service and repair men engaged in radio work have complained of trouble with their watches, in that these timepieces get magnetized in some fashion. Some of the service men have been at a loss to understand how this has happened, but one of the professional set builders believes he has a clue to the difficulty. The photograph above shows an individual working near a dynamic speaker, and it will be seen in the picture that the watch is relatively close to this dynamic. Inasmuch as the field of the dynamic speaker is rather strong, it would appear that the watch in proximity to the field of this dynamic might cause the timepiece to become magnetized. At least this is the cause that seems generally agreed upon. In the case of the magnetic fields from power supplies, the fields are not so likely to act upon a watch because they are pretty well isolated by the metallic cases in which the transformers and chokes are located. So, if you have been working near a dynamic speaker and your watch is magnetized, you may assume that the dynamic is to blame for it.

Increasing Insulation Factor

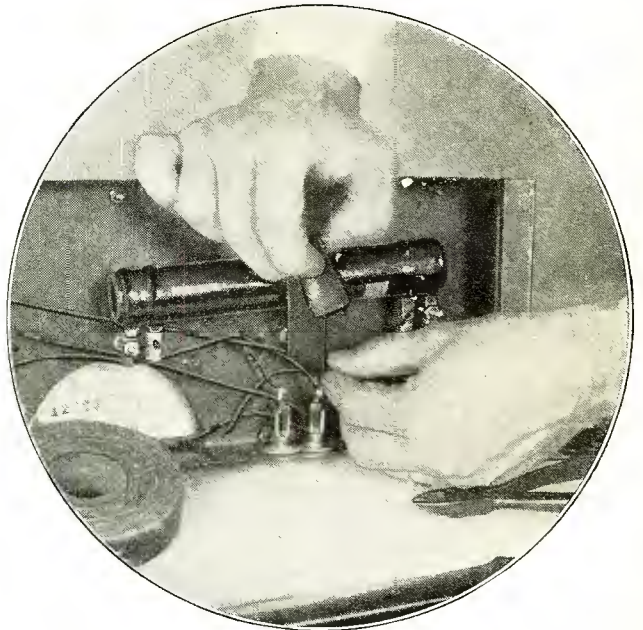

Service men in our laboratories have occasionally run across cases where the high voltage in a power supply will break through the insulation on the wire and may cause trouble by shorting to the chassis. This would be particularly true in the power supply having a maximum of 450 volts. The photograph shows an operator winding friction tape around the high voltage wire at the place where it comes near the chassis or where it crosses another wire of low potential. While the natural remedy would be to replace the wire with one of heavier insulation, nevertheless there are many occasions when the difficulty may be remedied by merely winding friction tape around that portion of the wire which is exposed to the chassis or wires of lower potential.



Hood for Television Lamp

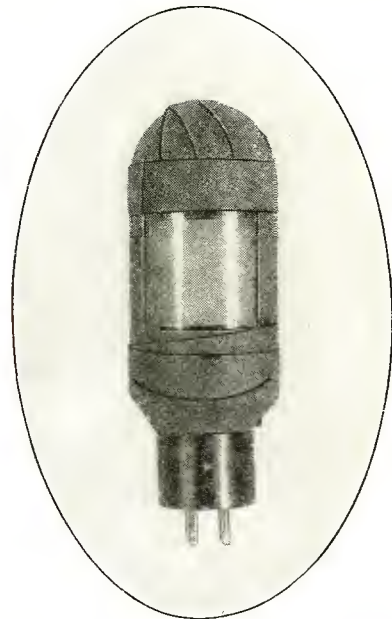

The television enthusiast will frequently find that when working with his set, there will be a considerable amount of reflected light, which will be somewhat bothersome when attempting to follow the images on the small screen. Some of this reflected light may be absorbed by the placing of a hood around the television lamp on all sides, except where the active plate is located. The photograph shows the method of doing this with ordinary friction tape, which may be removed whenever it is desired, without impairing the condition of the lamp or involving too much trouble. With such a hood, the television lamp will give a glow only at the plate which is seen through the aperture and any light from the sides or top and bottom will be absorbed by the dark color of the tape.

Don't Carbonize Wires When Soldering



One of our professional set builders was recently called upon to make a solder tap on an inductance and after doing so found that the receiver worked even worse than before. He was somewhat at a loss to find the reason for the failure of the set to work properly. On investigation he found that when he had soldered on the additional tap on the inductance, the heat from the soldering iron, when making the solder tap, had carbonized the insulation on one or two or possibly three wires adjacent to the solder tap. As a result of this carbonization, there was a partial short in the inductance at this position, which prevented the set from operating properly. The best way to solder a connection on an inductance or coil of any type, so as to keep the adjacent insulation from being burned or carbonized, is to elevate the one wire which is to be soldered from its neighbors and slip a piece of paper underneath this single strand so that the heat from the iron will not go through the paper and carbonize the insulation below. Another way of doing this is to elevate the strand by means of a match stem and then solder directly over the match stem in this fashion the iron being kept far enough from the adjacent insulation to prevent any possibility of burning.



Making It Easier to Read Meter

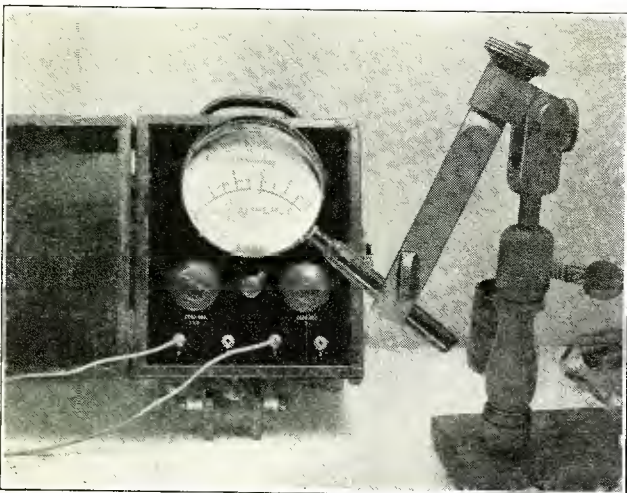

If the experimenter is called upon to do much measurement work or finds it necessary to take many readings on a meter, his work may be greatly simplified by the addition of a reading glass placed before the face of the meter and held in position by a stand or some other method of support, as illustrated in the photograph. When looking at the meter through this reading glass, the figures stand out quite prominently and there is not as much eye strain involved in doing meter reading as there would be were the glass not employed.

Vent Holes in Console Rear

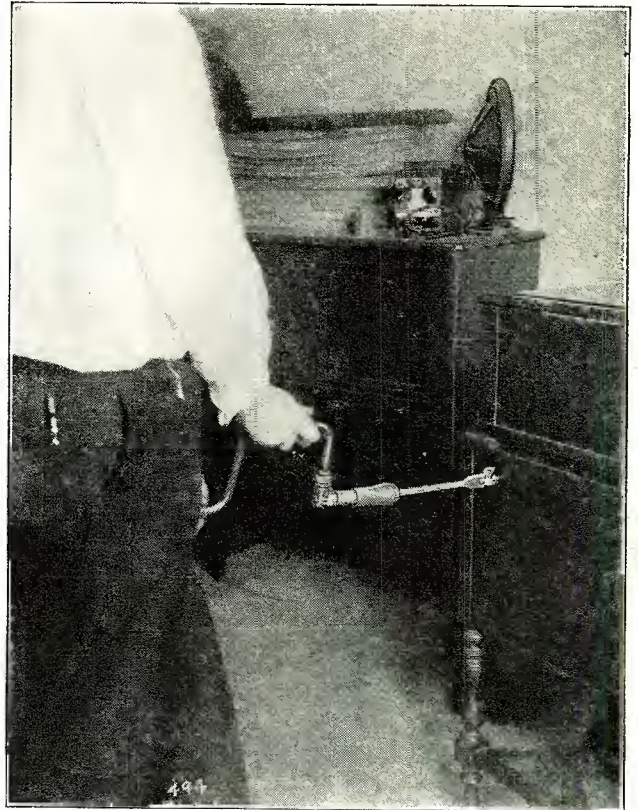

In many of the present day receivers, where the power supply and charger are placed in the bottom of a console, considerable heat is created by the charger and the power supply, which heat has a tendency to dry out the interior of the console. A certain amount of dryness is desirable, it is true, but too much of it may have an effect on the glue work inside the console. Two or three holes in the rear of the console may be bored by means of a brace and bit, preferably with an extension bit, so that these apertures may permit the escape of heat. Since heat rises, it is best to locate the holes towards the top of the lower sections of the console as illustrated in the above photograph.



Two Handy Radio Wrinkles

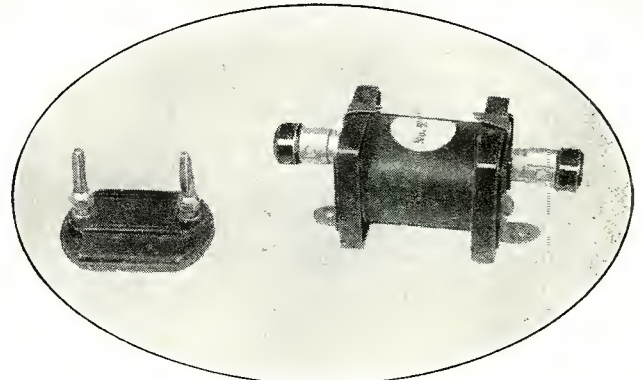

Here are a couple of handy radio wrinkles that should occur to the professional set builder or tinkerer, who wishes to save time and energy in experimental work. The scheme photographed at the left is a condenser having two plugs which may be easily fitted on the condenser. The condenser is a Sangamo type and the plugs are the conventional General Radio inductance plugs. Two jacks may be provided in the circuit so that this condenser with its plugs may be inserted therein whenever desired. A number of condensers made up in this fashion will enable the experimenter to switch from one value to another without changing wires or unscrewing any connections. The wrinkle illustrated at the right is another simple way of substituting radio frequency chokes of various sizes in a circuit. In this case, the Samson r. f. choke illustrated is equipped with two X-L binding posts, one at each end so that the choke may be placed in a circuit or taken out rapidly without any unscrewing of binding posts or anything else. In the case of the r. f. choke, it just so happens that the X-L binding post will fit on the stud, which is normally supplied with a knurled nut.

MAGNAVOX "Dynamic" SPEAKERS



The Belvedere

Two-tone walnut floor screen
 For A-Battery Operation . . . \$45
 For AC Operation \$55



First place in realism . . . extreme fidelity of reproduction . . . is accorded Magnavox Dynamic Speaker by fourteen makers of fine radio sets. They use it as built-in equipment to assure rich, undistorted reproduction, with great volume.

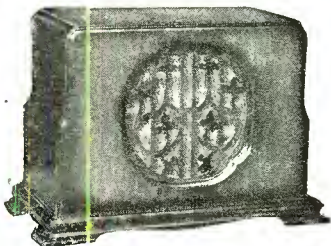

The Beverly

Grace'fully proportioned cabinet finished in light mahogany.
 For A Battery Operation \$50
 For AC Operation \$60

Other floor and table models up to \$175
 Units only; DC \$30; AC \$40.



THE MAGNAVOX COMPANY

Oakland, California Chicago, Illinois

Tell 'Em You Saw It in the Citizens Radio Call Book Magazine and Scientific Digest

Take CHANCES if you want to... but Don't Gamble on RADIO Parts

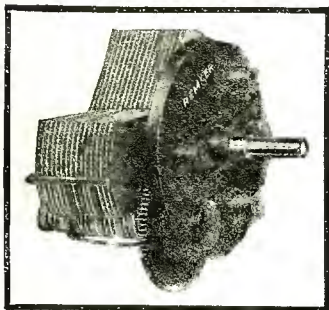

REMLER TWIN-ROTOR CONDENSER

Both sets of plates rotate... dial rotates through 360 degrees. Bakelite insulation

...minimum capacity especially low...high ratio of maximum to minimum capacity...S.L.W. and S.L.F. types.
Five different models, each.....\$5.00

TAKE chances—if you want to—but don't match your skill and experience against "bargain" parts and expect to win.

Parts with a pedigree, parts backed by ten years of radio experience, carry the name **REMLER**, and are illustrated on this page. Use them, and you will get the results you are entitled to.

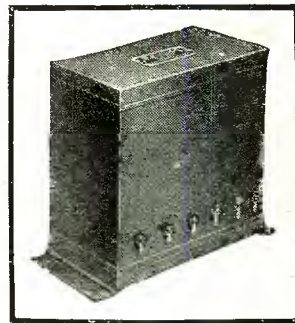

OUTPUT TRANSFORMER

Primarily for use following the CX 350 (UX 250) power tube...windings suitable for both magnetic and dynamic speakers...flat frequency characteristics.
No. 923.....\$20.00

AUDIO-FREQUENCY TRANSFORMERS

Four types that meet every need for faithful reproduction and tone-brilliance...No. 900 and No. 901 should be used together...No. 920 and No. 921 are also team-mates, both high-gain type...No. 900 and No. 920 resonant primary type.
Prices, each.....\$8.00 and \$12.00

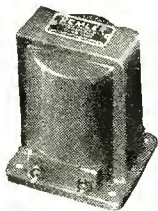

Write for descriptive circulars on any of the parts shown.

Ask us for complete constructional information on the Remler 29 and the Remler Power Amplifier.



BALLAST SHIELD

No. 55 for use with CX 301A (UX 201A) tubes or with CX 322 shield-grid tube...die cast body and copper shell prevent microphonic vibration of tube and act as electro-static shield.
No. 55.....\$0.90

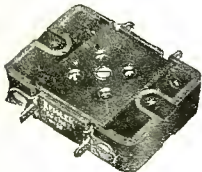

IMPROVED SOCKET

Designed for X-type, standard base tubes...positive contact...large contact surfaces...moulded bakelite...soldering lug terminals and screw terminals provided.

No. 50.....\$0.50

REMLER

Division of

Gray & Danielson Mfg. Co.

260 First St., San Francisco

Chicago

New York

SHIELDING CASE

Solid copper...sufficiently rigid...complete and effective shielding...3" wide by 5 1/2" deep by 5 3/4" high...top and bottom removable.
No. 720.....\$3.00

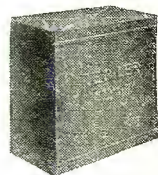

REMLER DRUM DIAL

Quiet, velvet smooth vernier control of any type of condenser...paper, aluminum or celluloid dial strips...6 volt lamp and bracket supplied...will drive single or

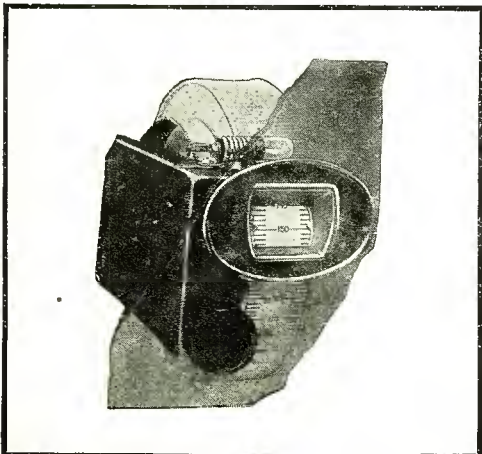

gang condenser from either right or left-hand side.
No. 110.....\$4.50

INTER-CHANGEABLE INDUCTANCES



No. 612...115 Kc. Transformer...terminal lugs fit directly into standard UX type socket. No. 614...115 Kc. frequency...tuned impedance.
No. 612; No. 614, each.....\$4.00

REMLER Compensating TRANSFORMER

No. 905...improves reproduction in any A.C. or D.C. circuit...replaces first audio transformer...resonant primary type...gives greater amplification to lower audio-frequencies...especially effective when used with dynamic speaker.
No. 905.....\$8.00



CHOKE COIL

Limits radio frequency currents to proper paths...has many uses...bakelite case...1 1/2 m.h.
No. 35.....\$0.90

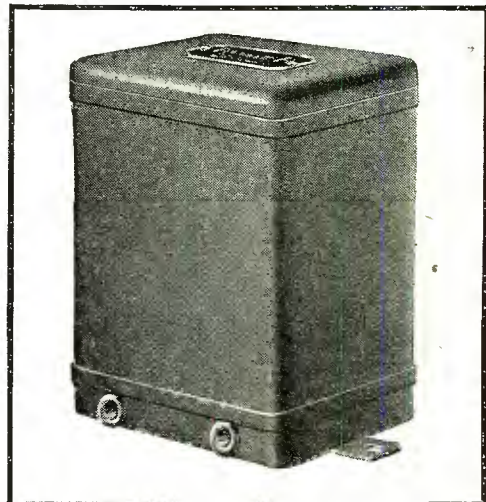

ALL ABOUT THE NEW R-D 22 AUTOMATICALLY TUNED SUPER-SIX RECEIVER THE NEW R-D 22

580 STATIONS ~ ~ ALL VERIFIED
120 OF THESE ARE FOREIGN STATIONS
80 OF THEM ACROSS THE OCEANS
48 CALIFORNIA STATIONS ~ ~ 5 WATTS UP
SOME DAYLIGHT RECEPTION
RECEIVED IN CHICAGO ON R-D RECEIVER
This is Record behind the New 1930 R-D 22

JOS. BASKYS OF CHICAGO LEADER IN DX RECEPTION WITH ROBERTSON-DAVIS RECEIVER

Perhaps you have wondered how Jos. Baskys leads all in the Chicago DX Club? He does, because he uses a Robertson-Davis Receiver! His log consists of 580 verified stations to date. 120 of these are Foreign Stations; 80 of them across the briny deeps. He has 48 verified California Stations ranging from 5 watts power up to 5,000 watts—all received from Chicago. He plays what he wants, when he wants to.

Just a Few Foreign Stations Played

RUS—San Salvador, 8:34 P. M., through all Chicago locals; JQAK—Manchuria, China; 7BY—Calcutta, India; KZRM—Manila, P. I.; 2BL—Sydney, Australia; 4QJ—Brisbane, Australia; JOCK—Nagoya, Japan; HBA—Berne, Switzerland; MRD—Toulouse, France; OFV—Vienna, Austria; OKB—Brunn, Czechoslovakia; IRO—Rome, Italy; KFQD—Anchorage, Alaska; OSLO—Oslo, Norway; 2LO—London, England; EAJ7—Barcelona, Spain; MTI—Budapest, Hungary; JODK—Seoul, Korea.

W. H. Wyman of Rock Falls, Ill., just out of Chicago, played 2LO—London at 3:45 A. M. for 30 minutes, and KGU—Honolulu 6 times consecutively.



THE NEW 1930 R-D 22 AUTOMATIC ROBERTSON-DAVIS RECEIVER NOW SUPPLIED COMPLETE AS SHOWN

The illustration to the left shows the new Robertson-Davis Super-Six Model for 1930. An automatically tuned receiver supplied complete with all parts and accessories, ready to hook up and use. A.C. operation entirely. Dynamic Speaker installed; using A-B-C Power Pack all combined in one, all contained in console. 3 Shield Grid A.C. No. 22 Tubes; 210 Push Pull. Supplied with or without Automatic Tuner.

Press a Button and Your Station Plays

Any six stations can be selected for automatic playing, and these can be changed at will on the R-D 22 Automatic Receiver. Depressing any button automatically cuts out all the rest, and brings in only the station desired from those adjusted to the Automatic Electric Tuner. A child of 3 can play it. Or, you can play any other station you wish to tune in, by using the single illuminated drum dial on the receiver, which operates independently.

The R-D 22 Standard Receiver has all of the features of the R-D 22 Automatic Receiver, except the Automatic Tuner. And, it is less in price.

THE 1930 R-D 22 SUPER-SIX IS AN AUTOMATICALLY TUNED RECEIVER
2,000,000,000 AMPLIFICATION—PERFECT TONE—PLAYS STATIONS
IN EVERY 10 K. C. BAND THROUGH EVERYTHING

R-D Super-Six Receivers have all features furnished with the world's best and most expensive receivers. They are beautiful in appearance, and years ahead of the time—up-to-date for many years to come. They are backed by an unconditional guarantee; thoroughly tried, tested and proved. What more can you ask of a radio receiver?

SHORT WAVE COILS. Short Wave or Television Plug-in Coils supplied to cover the 40-80 meter band, if desired. These work with the R-D 22 Standard Receiver.

This is your opportunity to have the best in radio for the lowest price.

MAKE REAL MONEY WITH THIS QUICKLY INSTALLED, FOOL-PROOF RECEIVER. WRITE FOR OUR PROPOSITION. GET DX OR LOCAL WITH INCOMPARABLE TONE AND VOLUME. SEND COUPON FOR FREE LITERATURE.

29
RCB-2

Robertson-Davis Company, Inc.
 361 W. Superior St.
 Chicago, U. S. A.

Gentlemen:

Please send, without charge or obligation, complete literature on the R-D Automatic Super-Six Receiver, Automatic Electric Tuner, All-Electric Power Pack, and Guaranteed Accessories to use with them. (Radio Dealer's Offer will be included, if indicated.)

The World at your fingertips
 with
ROBERTSON-DAVIS Automatic Radio

RADIO MEN: RADIO FANS:

ARE YOU NOW A RADIO DEALER? [If You Are, Enclose Card or Letterhead] YES NO

Name.....
 Address.....
 Town.....

Tell 'Em You Saw It in the Citizens Radio Call Book Magazine and Scientific Digest

New Silver-Marshall 720 A. C. Set Uses UY 224 and UX 245 Tubes

First Use of A. C. Screen Grid and Intermediate Power Tube
Seen in Modern S-M Design

FROM the laboratories of Silver-Marshall has come what is believed to be the first receiver designed to employ the new RCA and Cunningham UY224 (C324) AC screen grid tubes and the new intermediate power tube type UX245 (CX345). Not only is the receiver particularly interesting because of this feature alone, but it is even more so since its circuit design in which the new tubes are employed has been weighed in the balance of the 1928-29 season, using DC tubes, and found to be far from wanting in sensitivity, selectivity, and tone quality.

R. F. End Specially Designed

The new 720AC is a six tube broadcast receiver, the general assembly details of which have been made familiar to our readers through articles appearing in previous issues. It consists of a metal chassis $9\frac{1}{8}$ inches wide by $21\frac{1}{8}$ inches long upon which are mounted three stages of tuned and shielded screen grid radio frequency amplification, a detector, and two stages audio amplification using the Clough system of audio transformers. To this extent the new a. c. tube model is very similar to the former d. c. type, but the r. f. amplifier stages and the power output stage have been completely redesigned to utilize the new tubes to maximum efficiency. Three UY224 (C324) screen grid a. c. tubes are used in the three tuned stages of the r. f. amplifier system, two UY227 (C327) tubes serve as detector and first audio amplifier, and one UX245 (CX345) power tube furnishes a total of over 1.6 watts of undistorted power output to the speaker—performance heretofore obtainable only from the high voltage 210- or 250-type tube.

From a performance angle the receiver does everything that might be expected as a result of employing three of the new screen grid a. c. tubes which are, roughly, each twice as good as the d. c. screen grid tubes previously available, while its tone quality is all that might be anticipated from a 1.6 watt power tube of sufficiently low impedance to work efficiently into standard loud speakers—a tube which has been long needed and which really fills a long felt want. In direct comparative tests made by the designers the 720AC receiver has been found to provide greater selectivity, greater sensitivity, and appreciably finer tone quality than is obtainable from a standard eight-tube a. c. superheterodyne; while in the realm of tuned r. f. receivers, its performance has been found markedly superior to that of the most expensive types of factory-built, seven tube t. r. f. sets employing three, four, and even five tuned circuits. As a matter of fact, the new 720AC receiver has given performance practically equalling that of the Sargent-Rayment receiver—the set that is today recognized as being the most sensitive and selective radio receiver on the American market. And if any further indication of the performance that might be expected from this new set is needed, the fact that over half a dozen of the d. c. type sets were installed upon the Battleship U.S.S. California after tests which indicated that their operation was satisfactory under such adverse conditions as are found on an all-steel battleship housing, not one, but many powerful radio transmitters, is sufficient proof of the set's efficiency. Receivers of this type, located on the West Coast, have provided for their owners fairly consistent reception if Japanese, Australian, and East Coast stations; while sets

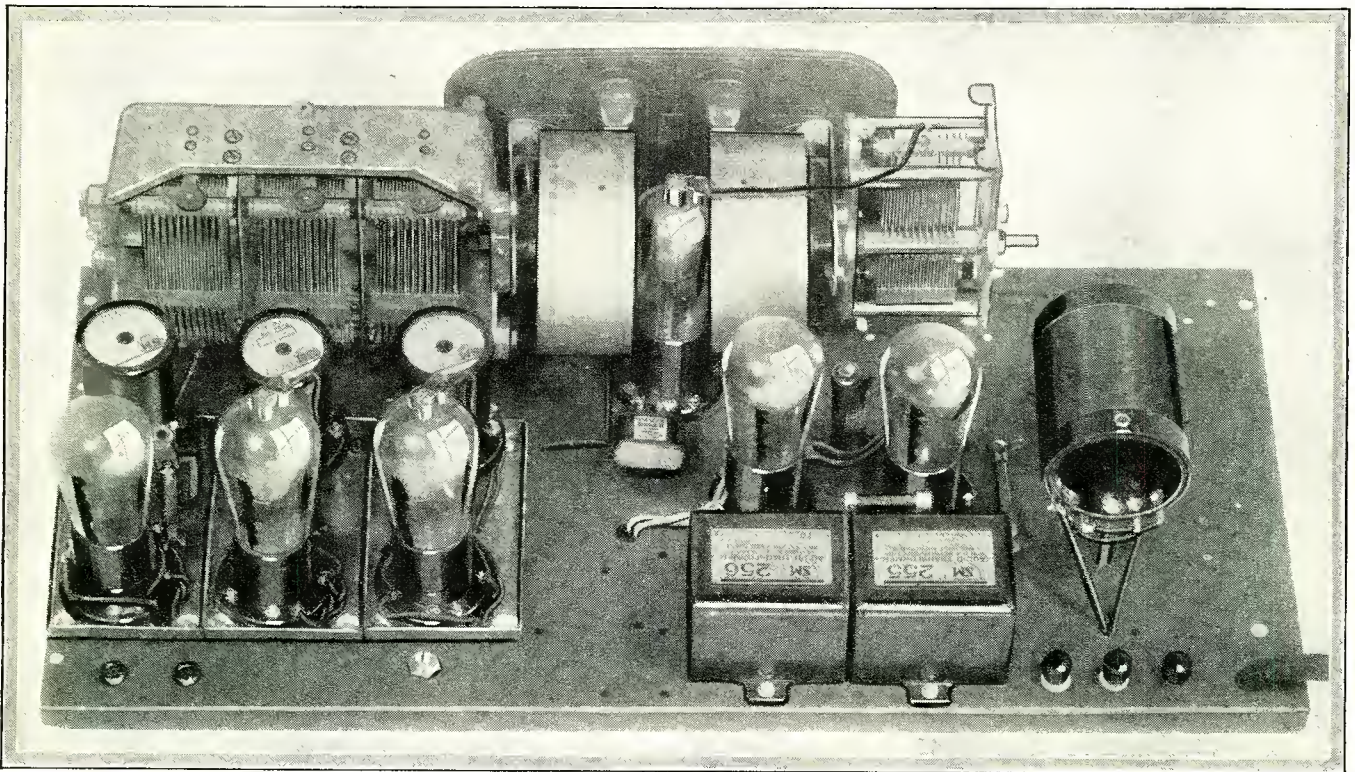

Fig. 1. This photograph shows a rear view of the 720 a. c. receiver described in the accompanying article. In this photograph the shields have been removed from the portion of the receiver shown at the left

(This receiver tested and all illustrations made in our laboratory)

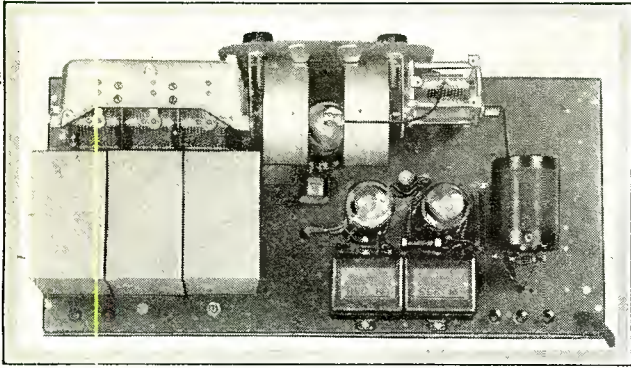

Fig. 2. In this photograph the shields are shown in place

in the Middle West and on the East Coast provide consistent reception of stations as far distant as California, Washington, and Oregon. And, from the performance of the model receiver submitted to our laboratories, it is felt that the 720AC receiver marks a very distinct step ahead in dependability of long distance reception with fine tone quality, and the high degree of selectivity necessary for present broadcasting conditions.

Electrical Details

A brief mechanical description of the receiver has been given in the foregoing paragraphs, and the electrical circuit will be apparent upon an examination of the schematic and pictorial diagrams. It will be noticed that the heater elements of the 224 screen grid and 227 a. c. tubes are all connected in parallel, to be lit from one 2.5 volt a. c. circuit of the 669 power supply. The 2.5 volt filament of the 245 power tube, shunted with a balancing resistance and with the C bias resistor connected between the center tap of this resistance and ground (and bypassed by a 1 mfd condenser) is lit from the second 2.5 volt source found in the 669 power supply. While the heater voltage for the screen grid and 227 tubes is exactly the same as the filament voltage for the power tube, the fact that the arm of the hum balance potentiometer for the heater tubes must be connected to ground precludes the possibility of lighting the 245 tube from the same filament source, for its filament must be at a potential above ground equal to that of its C bias voltage, or 50 volts. Obviously, these two require-

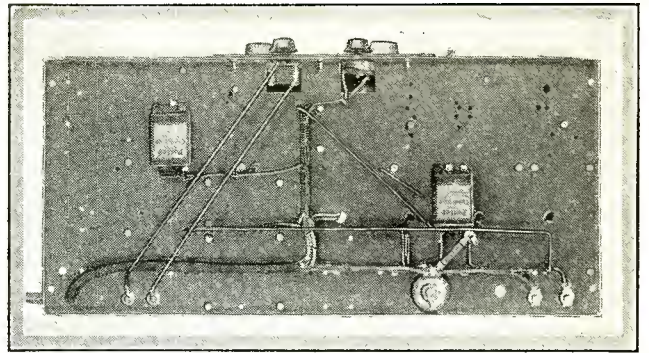

Fig. 3. This photograph gives an idea of the facility with which such a receiver may be wired, since if desired the wiring may be neatly cabled as shown in the photograph

ments are incompatible, and for this reason two separate 2.5 volt filament sources are utilized. B voltages are taken from the power unit at three values, viz.: 67½ volts for the detector plate circuit, and the screen grid control potentiometer; 180 volts for the plate circuits of all tubes except the power tube; and 300 volts for the plate circuit of the power tube. As a matter of fact, the required C bias for each tube is subtracted from these voltages by means of proper resistances located in the receiver so that, for example, the 300 volts furnished by the 669 power unit are actually divided, 50 to the grid, and 250 to the plate, of the 245 power output tube. All of the new tubes in the receiver are operated at their maximum rated voltages so that the best possible results may be anticipated.

Low Loss Coupler

A large, extremely low-loss antenna coupler, tuned by a single .00035 condenser, appears at the left of the schematic circuit diagram. This coupler provides a very high voltage step-up between antenna and first r. f. tube, and has a selectivity adjustment in the form of a .00075 midget condenser, as well as two taps on its primary. Both this coil and the first r. f. tube are unshielded, though the tube itself is substantially shielded by being located between the two metal vernier drum dials. The three succeeding tuned circuits, each employing a small plug-in r. f. transformer, a

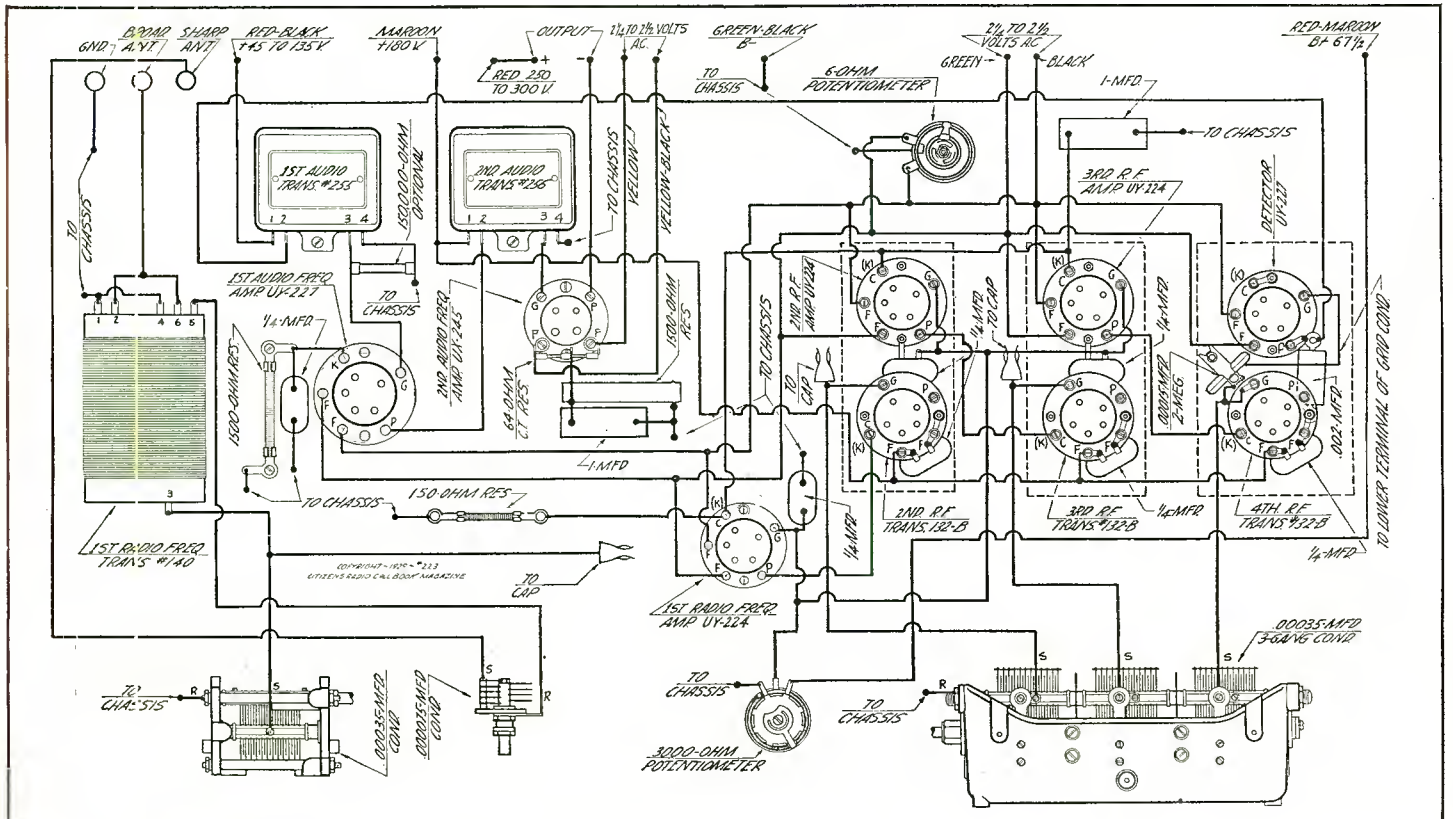

Fig. 4. This diagram is a graphic one, by means of which the novice may wire up the 720 a. c. receiver

section of the .00035 condenser, and a tube with the necessary screen grid and plate bypass condensers are each housed in one of the three copper stage shields seen on the chassis. This arrangement provides complete and effective shielding, with extremely short grid leads from the rugged gang condenser to each tuned circuit. The gang itself is provided with three individual compensators which allow each stage to be adjusted to peak efficiency. The receiver is obviously a two-control set, tuned by two major drum dials and with a volume control potentiometer and antenna selectivity adjustment (midget condenser) located on the main control escutcheon at the front of the chassis.

The audio amplifier consists of the well-known S-M 255 and 256 audio transformers with a UX 227 tube in the first stage and a UX 245 power tube in the second stage. No output transformer is included in the receiver, as it is assumed that the set will be used with a dynamic speaker having its own output transformer; or, if a magnetic speaker is employed, that an output device such as the S-M 222 transformer will be connected between the loud-speaker tipjacks of the set and the speaker itself for protection. The volume control for the receiver, which effectively controls volume from an absolute zero to maximum, is in the form of the 3,000 ohm wire-wound potentiometer in the screen grid circuit. This is an extremely satisfactory and efficient method of control and the one recommended for the new tube.

The assembly of the receiver is extremely simple and requires only a few hours, for all parts are available in complete kit form and complete detailed instructions may be had from the manufacturers. There is no point, therefore, in taking valuable space to describe the actual construction details of the set.

The completed receiver may be housed in any standard console cabinet or in the S-M 700 metal shielding cabinet, the latter being desirable even though the set may be placed in a console. For this metal shielding cabinet contributes to the effective selectivity of the set. The accessories required are an antenna of from 20 to 50 or more feet long, a suitable ground connection, a dynamic speaker such as the S-M 850 A. C. type or the 851 D. C. type, and the following tubes:

- 3—UY224 (C324) screen grid A. C. tubes
- 2—UY227 (C327) A. C. heater tubes
- 1—UX245 (CX345) new power tube

All power for the receiver is obtained from the S-M 669 power supply unit which consists of a heavy full-wave power transformer, a UX280 tube, a suitable condenser bank, a dual filter choke and, of course, the necessary voltage dividing resistances all housed in a case. The power supply itself is extremely simple and as its design details do not deviate in any way from those of Silver-Marshall units already familiar to our readers, no description is presented herewith.

Official Parts List

Parts required for the construction of the 720 A. C. receiver

are shown below:

- 1 Silver-Marshall 701 Universal pierced chassis
- 1 Silver-Marshall 809 dual control escutcheon
- 1 Silver-Marshall 806L (left) vernier drum dial
- 1 Silver-Marshall 806R (right) vernier drum dial
- 1 Silver-Marshall 320R .00035 mfd Universal condenser
- 1 Silver-Marshall 323 .00035 mfd 3-gang condenser
- 1 Silver-Marshall 342B .000075 mfd midget condenser
- 3 Silver-Marshall 638 Copper stage shields
- 1 Silver-Marshall 140 antenna coil
- 3 Silver-Marshall 132-B plug-in r. f. transformers
- 8 Silver-Marshall 512 5-prong tube sockets
- 1 Silver-Marshall 511 tube socket
- 1 Silver-Marshall 255 first stage audio transformer
- 1 Silver-Marshall 256 second stage audio transformer
- 1 Silver-Marshall 708 10-lead 5 ft. connection cable
- 1 Silver-Marshall 818 hook-up wire
- 1 Yaxley 5300 3000 ohm midget potentiometer
- 2 Yaxley 420 insulated tip jacks
- 1 Yaxley 150 ohm resistor
- 1 Carter A6 6 ohm sub-base rheostat

(Continued on page 116)

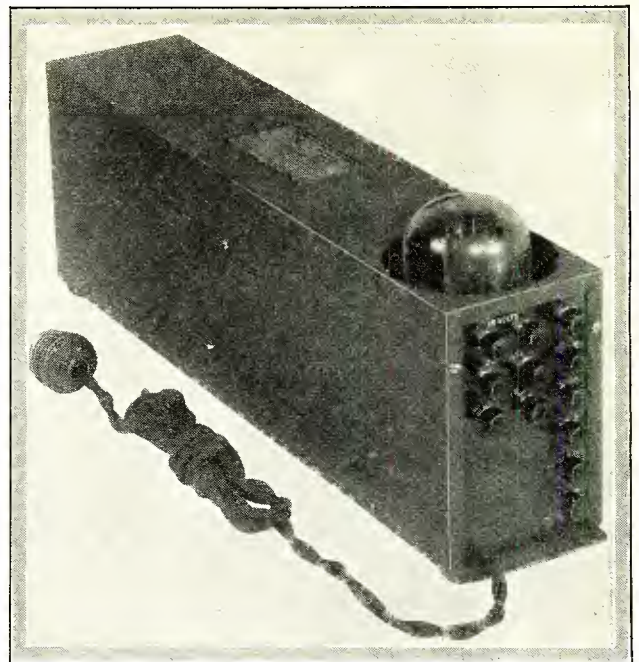

Fig. 5. This photograph shows the Silver-Marshall 669 A, B and C supply recommend for use with the receiver described herein

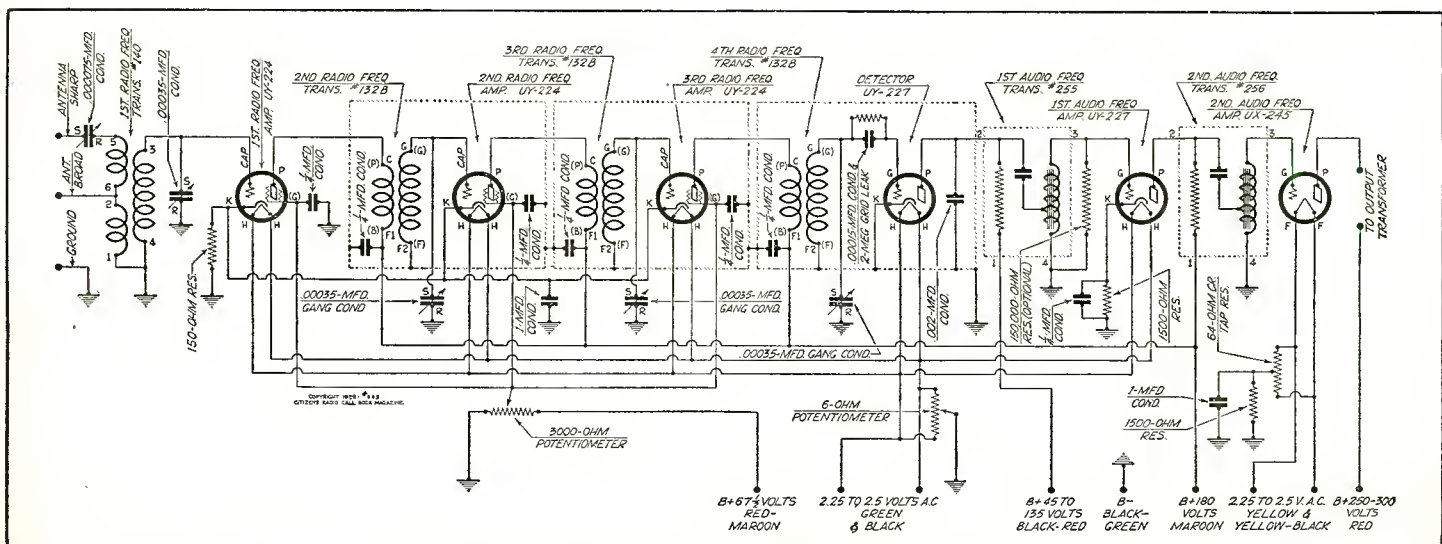

Fig. 6. The electrical details of the circuit are disclosed in the schematic diagram shown above

Two Audio Transformers Are Added to Citizens Junior Two Tube Set

Previous Construction Article Gave Data for Building the R. F. and Detector Stages

JUNIOR radio builders, who have read the article on page 78 of the January issue of this magazine, will remember that in that article the receiver was only shown as a two-tube job and a promise made that in a succeeding issue two more tubes would be added so that the complete receiver could be made. However, in the first article provision was made for one stage of radio frequency and a regenerative detector, so that the builder could be using the set and later when the second article appeared he could add the two audio transformers and two sockets so as to bring it up to a four tube set.

Making It a Four Tuber

This work has now been done and in the accompanying article it will be shown how the change-over is made to convert the two-tube job into a four-tube job. The photograph shown in Fig. 1 illustrates the completed receiver. Comparing it with Fig. 1 in the January article, it will be seen that the layout is exactly the same, the only changes being the addition of two extra sockets and two audio transformers. The electrical connections of the circuit are shown in Fig. 3, which is the schematic diagram, while the graphic wiring diagram in Fig. 2 enables the novice to put together the receiver without any trouble. Needless to say, regardless of whether the receiver has been wired by the schematic or the graphic, it should be checked over afterwards to make sure that no wrong connections have been made.

By reference to the list parts on page 126 of the January issue,

it will be observed that there are only four items different in the new list of parts. The list of parts for the two-tube job takes care of everything in the receiver except one Thordarson R-151 6-1 audio transformer, one Thordarson R-152 2-1 audio transformer, one Yaxley 2 ohm fixed resistance instead of the 4 ohm fixed resistance as in the previous model and four Frost 530 sockets instead of the two Frost 530 sockets, as in the previous job. However, at the end of this article a list of parts is given as a complete unit for the four-tube receiver.

Where in the previous model, the head phones are placed between the B45 binding post and one end of the regenerative winding, as illustrated in Fig. 4 of the January article, in the present receiver head phones are taken from that position and the primary of the first audio transformer substituted. This may be seen by referring to Fig. 2, the graphic diagram accompanying this article. The head phones or speaker are now transferred to a position where they are located between the B plus 135 volt binding post and the plate of the last tube.

The two extra sockets are added in line with the other as shown in the photograph, Fig. 1. The two audio transformers are also placed in the same fashion with the 6-1 ratio transformer coming first and the 2-1 ratio in the second stage. The two ohm resistance required for the present job takes the place of the four ohm fixed resistance located between the A plus and the common plus filament line of the two sockets in the preceding article.

In order to bias the grid of the first audio and second audio

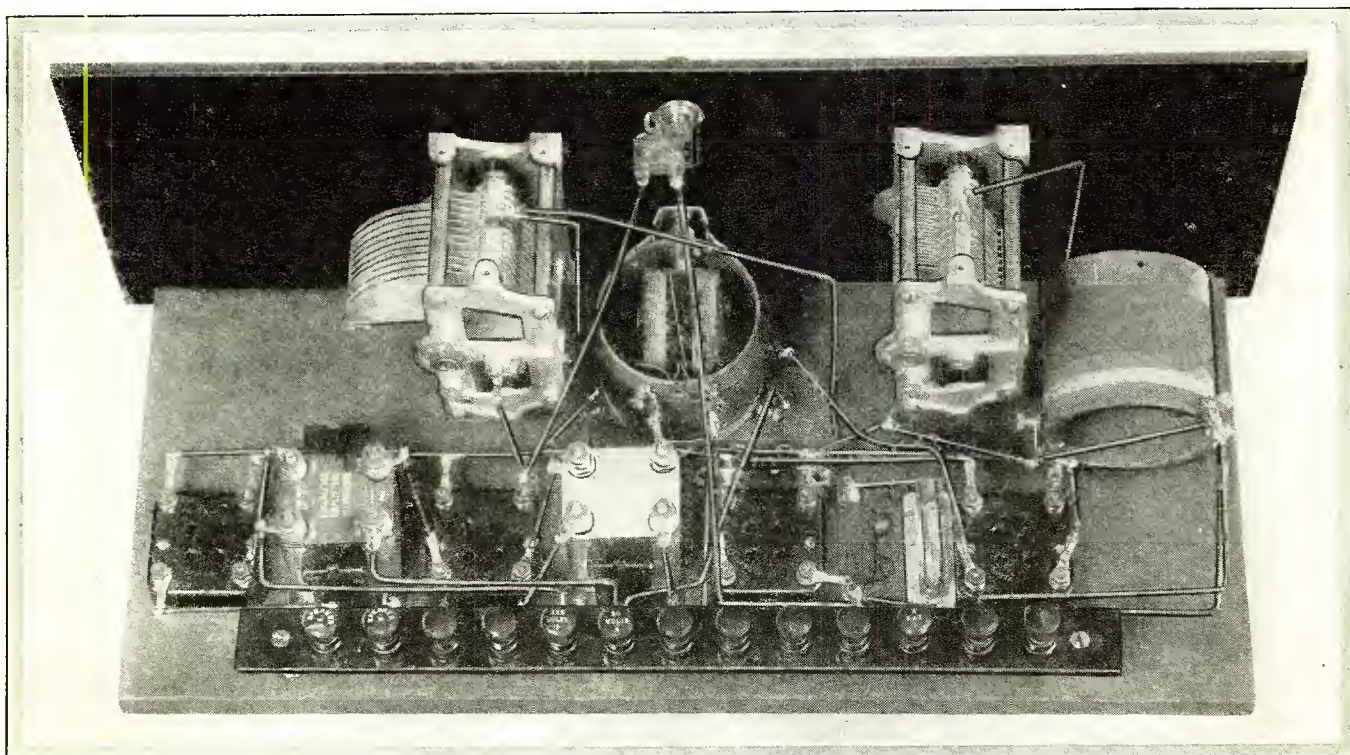

Fig. 1. This photograph shows the completed four tube receiver. In the article appearing in the January issue, the two sockets and the two audio transformers were not shown in the photograph. In the present article, data is given for the addition of the two audio stages

(This receiver designed, tested and all illustrations made in our laboratory)

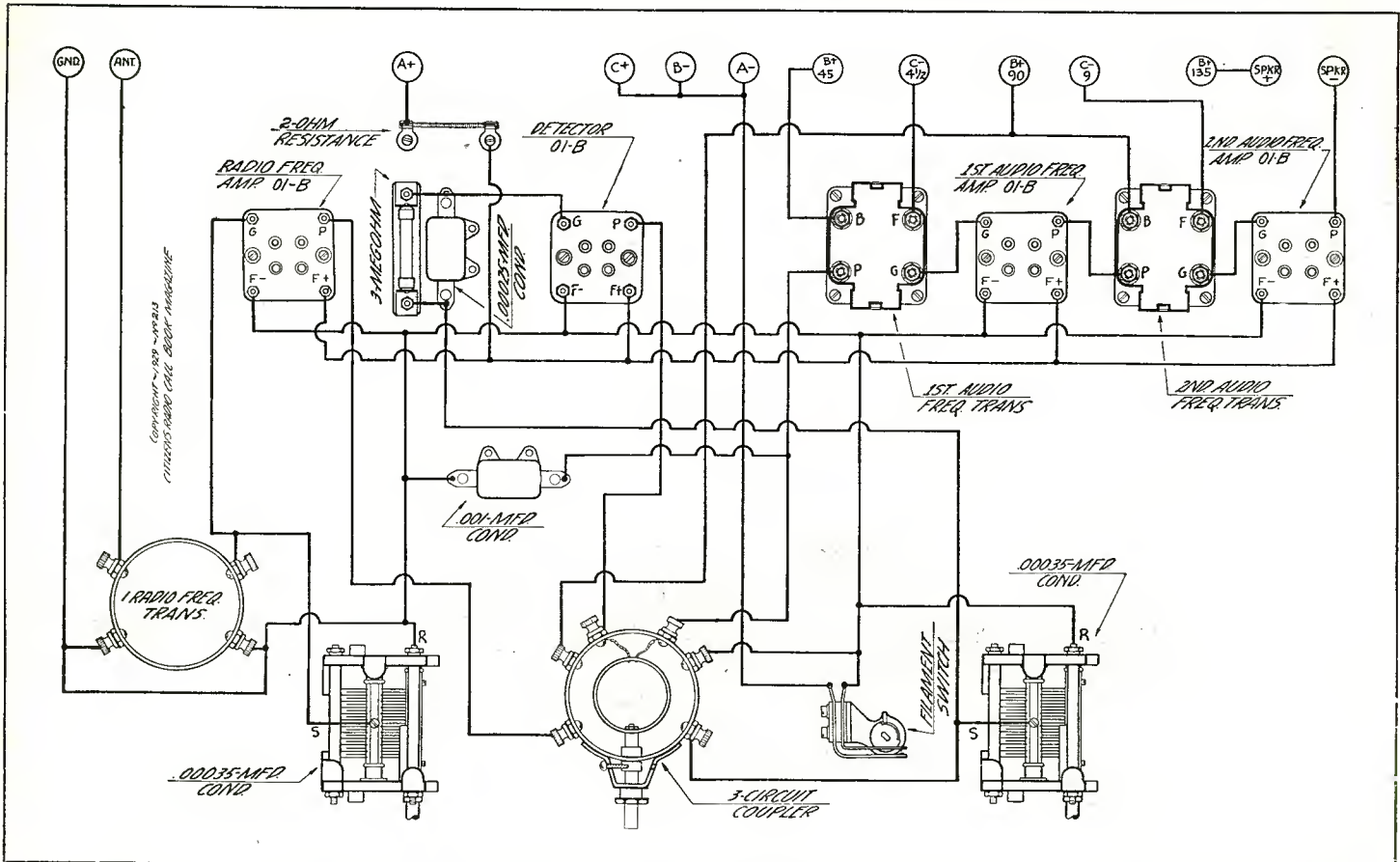

Fig. 2. This graphic diagram will help the builder wire up his receiver rapidly, especially if the constructor is not familiar with the schematic circuit. The only addition to the previous receiver is represented by the two tube sockets and the two audio transformers together with a little rewiring

stages, a small C battery, with a maximum of 9 volts, is required. For this purpose two 4½ volt C batteries may be placed in series, the C-4½ going to the F terminal of the first audio transformer, where it biases the grid of the first audio tube, and the C-9 tap of the battery going to the F terminal of the second audio transformer, where it biases the grid of the last stage tube. Since there is no current drain on these batteries, they will last their shelf life in the receiver. As a rule they need not be changed oftener than every eight or ten months.

In the previous receiver, the head phones were sufficient for listening in, since only a stage of radio frequency and regenerative detector were used. However, in this model, it is quite likely that it will be necessary to have a small loud speaker, because the volume on the head phones will probably be too great for personal comfort. However, if one desires to use head phones, he may do so and reduce the volume by means of the regenerative knob on the receiver.

Current Drain Small

In the previous receiver, it was only necessary to have two 45 volt blocks of B battery. However, in this model, on account of the audio stages, it will be necessary to have one more 45 volt block, giving a total of 135 volts overall. The current drain of the receiver is exceedingly small and for that reason the B batteries should last for quite a while.

Tuning of the receiver is the same in both models. A signal is first tuned in on the left-hand dial, followed by the right-hand dial. Volume is changed by means of the regenerative knob in the center of the panel. This manner of tuning refers principally to the reception of local stations, or stations with a strong signal strength. However, for weak stations it is frequently necessary to tune in these weak signals with the detector first, and the tube in an oscillating condition. Thus, the regenerative knob is turned until a whistle is heard and then the left and right dials turned back and forth until the whistle becomes loudest. Then the regenerative knob is turned back until the whistle disappears and the music comes through.

Sharpening the Tuning

With the fixed antenna winding on the r. f. coupler, there may be occasions when tuning will seem broader than necessary. Under these circumstances, it will be possible to sharpen the tuning a little by the insertion of a small fixed condenser, about .00025 mfd in series with the antenna and the antenna binding post on the receiver. It is also possible to sharpen up the tuning by cutting down the length of the antenna, although perhaps the use of a fixed condenser in series would be preferable.

Official Parts List

Parts required for the construction of the Junior Four Tube Receiver as described in the article herewith are shown below:

- 2 Amsco .00035 mfd variable condensers
- 1 Frost .00025 mfd fixed condenser
- 1 Frost .001 mfd fixed condenser

(Continued on page 112)

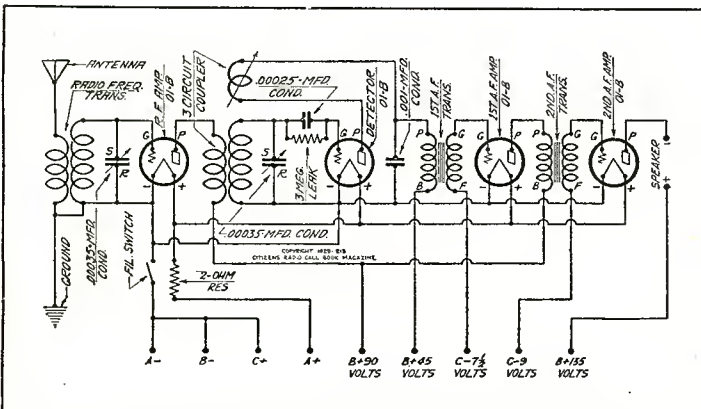

Fig. 3. This is the schematic circuit of the four tube receiver and shows the electrical connections involved in the set

Adding Tube Shield Boosts Range of Aero International Four

Much Better Signal Strength Obtained When Screen Grid Tube Is Shielded and Wiring Cabled

ORIGINALLY described in the September, 1928, edition of this magazine on page 63, the Aero International Four receiver has since undergone some revision on the part of the manufacturer and as a result its distance getting ability has been very materially increased. Although the screen grid tube itself has been responsible for exceptionally good results with the four tube receiver, nevertheless by the additional screen for the tube, or a shield, it is now possible to work up the amplification of the receiver to a point where the signal strength is practically double of the unshielded model.

Another point in the wiring of the receiver which has contributed quite a bit to the increase in signal strength is the fact that the high potential lines running to the 222 tubes are cabled and thus guarded from stray capacity effects. We have been advised by the designers that in tests which they recently conducted, the receiver as shown in this article has a considerably stronger signal strength than an entirely shielded short wave receiver where all parts are put together in different compartments. It has even developed a much louder signal strength in the same circuit with the shield grid circuit shielded and tuned.

It will be observed by those who refer to the schematic in Fig. 5 that not only the Carter tube shield, but the grid wire to the 222 tube is shielded and both of these kept at ground potential. The wire running from the antenna post on the receiver to the control grid is Belden shielded wire. This may be seen in the photograph illustrated in Fig. 1. Examining the schematic circuit shown in Fig. 5, the reader will see that the input circuit of the screen grid tube is untuned. The No. 65 r. f. choke coil placed between the tap of the tube and the bottom of the 10 ohm filament resistance, which is common with A minus, serves as an aperiodic choke and permits waves of various lengths to be tuned by that circuit. The plate circuit of the screen grid tube has in series with it the secondary inductance, which is tuned by the .00014 mfd variable condenser and is coupled to the detector through the .00015 mfd grid condenser. The grid leak is from the grid to the negative filament.

Regeneration is by means of the tickler coil and the throttle condenser, which is a .00025 mfd variable. There is a No. 60 r. f. choke placed between the regenerative coil and the primary of the first audio to

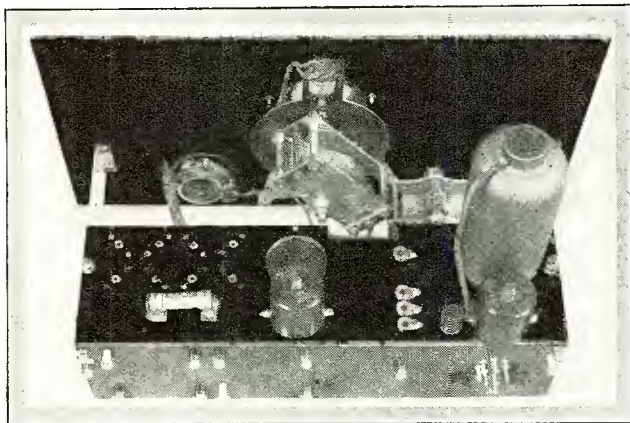

Fig. 1. This is a photographic view of the rear of the Aero International Four, showing the tube shield in place at the right

prevent the passage of stray radio frequency currents into the audio amplifier.

Another No. 60 r. f. choke coil is placed between the F terminal of the secondary inductance and the B 180 volt line, this being to prevent common coupling with the batteries. The radio frequency choke in the 180 volt line is bypassed to negative with a .003 mfd fixed condenser and another condenser of the same value is placed between the screen grid of the tube and the negative A battery as an r. f. bypass.

In the audio side, there are two Aero audio transformers, the secondary of the first stage going into the first audio amplifier tube and the secondary of the second stage leading to a 171-A power tube. Grid bias for the 171-A is by means of the C minus 40 volt terminal while the bias for the first stage is that afforded across the ½ ampere ballast located in the negative filament of the first audio tube.

Filament Connections

The proper bias for the grid of the screen grid tube is obtained by the drop across the 10 ohm resistance in the negative filament of that tube, while the voltage is dropped to the proper value by means of the combined 10 ohm biasing resistance and the 15 ohm fixed resistance shown in the schematic. The positive side of the detector filament has in series with it a 20 ohm rheostat by means of which the brilliancy of the tube may be changed, while the two audio stages are of the fixed type, since a ½ ampere ballast resistance is used for the 171-A and the 201-A.

The wavelength range of the receiver with the three plug-in coils included in the LWT-10 kit is from 17 to 89 meters, and with the number INT-104 sold separately, 155 meters, arranged to include all short wave stations broadcasting at present or contemplating, as well as the principal amateur phone and telegraphic band.

Cabling of Leads

In the wiring of the receiver, there are several points which should be brought to the attention of the builder, so that he may secure the maximum efficiency from the completed job. In the first place, all the low potential lines, such as the filament wires, plus and minus, may be cabled together by means of thread or string. The grid and plate wires should be isolated, or kept



Fig. 2. The front panel view of the receiver is shown in the above photograph. The knob at the left controls the regeneration condenser, while the central knob is the one of the drum dial. The knob at the right is the combined 20 ohm filament rheostat and filament switch

(This receiver tested and all illustrations made in our laboratory)

Citizens Booster Stage Is Operated from the A. C. Light Line

Balanced Bridge Circuit Is Used to Give Greatest Gain Consistent With Receiver Stability

HAVING appeared first in the March, 1928, issue of this magazine, the Citizens r. f. amplifier has met with some success on the part of set builders who desire to add a tuned stage of radio frequency instead of an existing receiver. However, there have been many requests for such a booster stage operated from alternating current to take care of a. c. receivers from which more volume is required.

Designs Almost Alike

The design shown in the accompanying article and the one shown in the March, 1928, issue are practically alike as far as the radio frequency end of the circuit is concerned. The point of difference lies in the fact that in the one shown in March, the filaments are energized from a storage battery, whereas in the present circuit the 226 tube is employed and this is energized from either a separate transformer having a 1½ volt winding or from the 1½ volt winding on the transformer located in the receiver itself. In the event the booster is operated from the filament transformer in the receiver itself, the components 1, 2 and 3 shown in the schematic diagram, Fig. 3, are omitted because an automatic grid bias will be obtained from the resistors in the receiver. If a separate filament transformer is utilized for obtaining the filament current for the 226 tube in this a. c. booster stage, then it is necessary that the two resistors and the ½ mfd condenser be retained in the design so as to provide a bias for the 226 r. f. amplifier tube.

Balanced Bridge Circuit

Examination of the schematic circuit shown in Fig. 3 will give a general idea of the unit. The r. f. transformer consists of a primary and a secondary. The two windings are placed on a 1¼ in. diameter piece of Formica tubing 3½ in. long. The primary winding which is in series with the antenna and ground consists of 17 turns of No. 26 enamel. The secondary winding consists of 52 turns each side of a center tap. The wire size is No. 26 enamel. A space of a ¼ inch is allowed between the primary winding and the secondary winding, this space being for coupling. In the event that the unit may seem broad in tuning (if there is ample signal strength), broadness of tuning may be cut down to some extent by removing two or three turns from the primary or else by allowing a greater spacing between the primary and secondary windings. In the case of the secondary winding, it is essential that the number of turns each side of a center tap be exactly equal. As shown in the schematic, the center tap is connected to ground and the bottom side of the antenna coil. The upper section of the secondary goes to the grid of the 226 tube and to one side of the .00035 mfd condenser.

In the case of the Remler condenser used, it does not matter which side goes to grid, because both of the rotors are insulated from the shaft of the condenser. The second half of the secondary connects to the other side of the .00035 mfd variable condenser and to one side of a .000025 mfd midget condenser, the connection being made on the stator, while the rotor goes to the plate of the 226.

The plate circuit of the 226 tube has an r. f. choke, as shown in the schematic, in series with the positive 90 volt line. This r. f. choke is bypassed by a .00025 mfd condenser. The output of the booster stage goes to a ½ mfd condenser onto the antenna post of the receiver itself. Inasmuch as the booster is grounded, as well as the receiver, there is only one connection necessary, that being the output connection previously mentioned.

Bias for R. F. Tube

When the filament of the 226 is energized from a separate transformer, a center tapped resistance varying from 20 to 60 ohms should be placed directly across the terminals of the socket, or near by. From the center of this center tapped resistance is placed a 1000 ohm fixed resistance to ground and the 1000 ohm resistance bypassed by a ½ mfd fixed condenser. It is this resistor which provides the grid bias for the 226 tube. If the filament transformer in the receiver is being employed, it is not necessary for the two resistors and the bypass condenser to be included in the unit.

The reason underlying the selection of the balanced bridge circuit in this particular unit is that it is desired to secure as high an r. f. gain as is possible without encountering tube instability. This particular bridge circuit allows the balancing of the tube at any point within the range of the inductance spanned by the condenser. For example: the receiver can be made regenerative either at 200 meters or at 500 meters as desired by the operator. The position at which regeneration begins is determined by the setting of the midget condenser located inside of the shielded can. Schematically the circuit has all the appearances of a three-tapped loop circuit on a superheterodyne, except that the balancing of this inductance and tube is a much easier matter than balancing the loop circuit of a super.

Those readers who have seen the previous article on this subject would do well to refresh their memories by referring to page 92 of the March, 1928, issue, with particular reference to the diagram shown in Fig. 4. In the upper portion at the right hand of Fig. 4 is shown a sketch of the coil form and the winding. However, the number of turns on the d. c. job and the number on the present a. c. booster are not the same. In the first model, the windings were made with No. 26 double silk covered wire, whereas in the present design the wire has been changed to No.

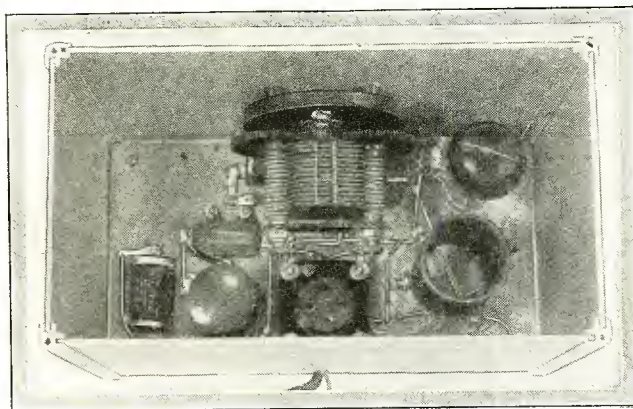

Fig. 1. Photographically is shown above the a. c. booster stage recently designed in our laboratory. This unit is somewhat after the fashion of the one which appeared in the March, 1928, issue of this magazine, except the previous model was for storage battery operation, whereas this one is alternating current operated

(This booster designed, tested and all illustrations made in our laboratory)

The Hollister AC-8 Electric Operated Super Is Now Available

Alternating Current Screen Grid Tubes in New Kit Which Is Identical With Lincoln 8-80

It will be of interest to the many builders of the Lincoln 8-80 receiver to know that a new kit is now available using a. c. tubes throughout. This new receiver will be welcomed by many builders who have objected to the battery or eliminator powered receiver.

General Specifications

The general lay-out of the Hollister AC-8 is identical with the Lincoln 8-80. The front panel is of attractively grained walnut bakelite—7x21—in which is incorporated the two drum dial windows, two drum dial control knobs, one volume control and switch knob.

Two selector variable condensers are independently operated by the two illuminated drum dials, allowing the operator to know accurately the exact setting for a given signal. The eight tubes and all transformers are in a straight line, simplifying construction to a minimum. All wiring is done beneath sub-base, which is composed of bakelite, eliminating possible shorts, and creating good insulation for all component parts. Dimensions of the sub-base are: 21 $\frac{3}{8}$ in. long by 9 $\frac{7}{8}$ in. wide. Substantial double contacts in sockets are assembled in bakelite base ready for wiring.

A newly designed illuminated drum dial is used on the Hollister AC-8. The drums are operated by a very flexible copper cable. Absolutely no back-lash is possible, and perfectly smooth operation is obtained. Drum dial and variable condenser assembly is independent of front panel, being mounted on sub-base. This is very desirable for special console installation where dif-

ferent type of front panel may be desired.

The tubes employed are as follows: oscillator, 227 type; first detector, 22 a. c. type; three intermediate stages, 22 a. c. type; second detector, 27 type; first audio, 27 type; second audio, 210 or 250 type.

Sharp Input Tuning

Antenna coupler No. 103 a. c. is composed of a large bakelite threaded shell wound with No. 16 enameled wire; tapped for antenna, one-third distance from negative end. This type of coupler has been found to be very efficient for sharp input tuning.

Oscillator coupler No. 102 a. c. composed of tickler, grid and pick-up coils is equipped with lugs extending through bakelite base, where all grid, plate and pick-up connections are easily made.

The well known Lincoln 101 tunable intermediate transformers are composed of heavy copper shells housing the transformer windings and variable condenser. The merit of these transformers has been many times proven by the many builders of the Lincoln 8-80 receiver. Unquestionable advantage has been proven in actual practice, using the No. 101 intermediates with the screen grid tubes. High amplification, stability, absence of oscillation, allowing tremendous gain without broadening, has been the universal report when these transformers were used with the d. c. tubes. The same characteristics have been proven, when used with the a. c. screen grid tubes.

The Clough system of audio amplification, composed of No. 105, first audio, and No. 106, second audio, was again chosen, as

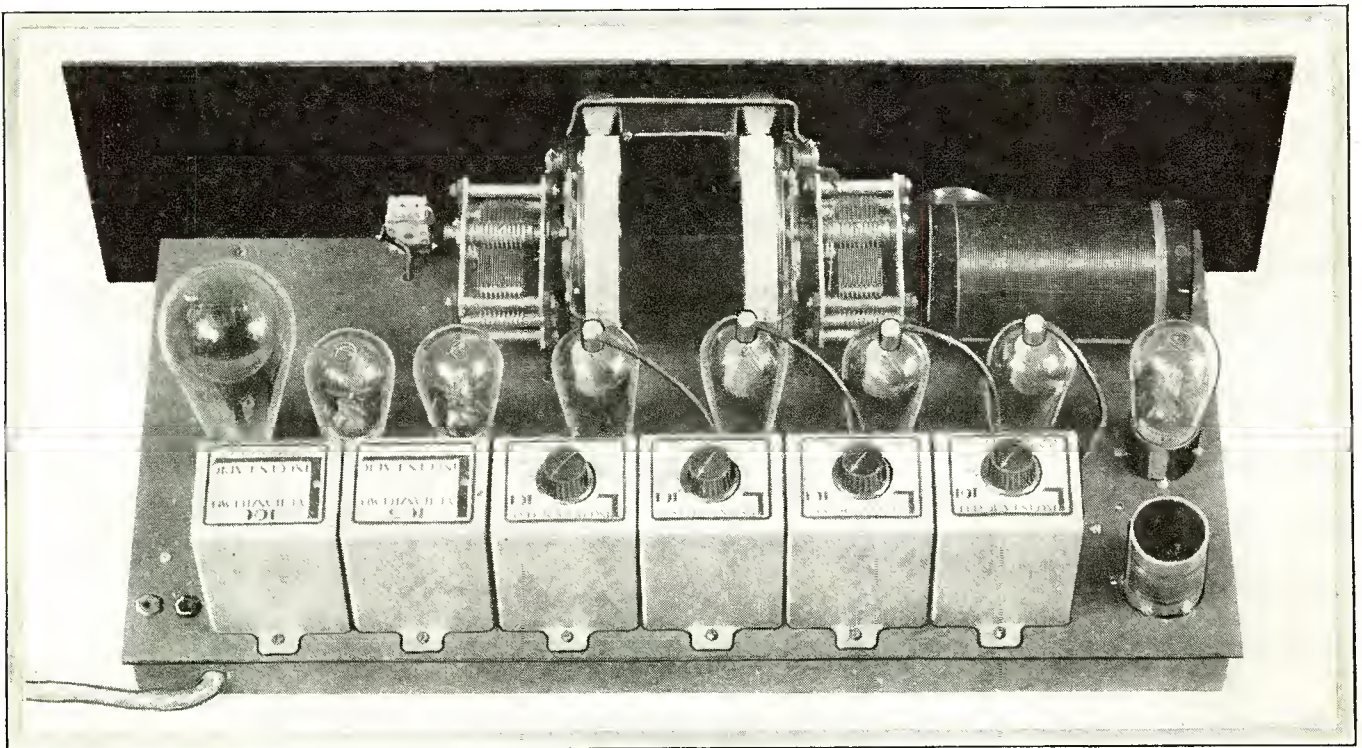

Fig. 1. Either a 210 or 250 tube may be used in the last stage in the Hollister AC-8 which is photographed above

(This receiver tested and all illustrations made in our laboratory)

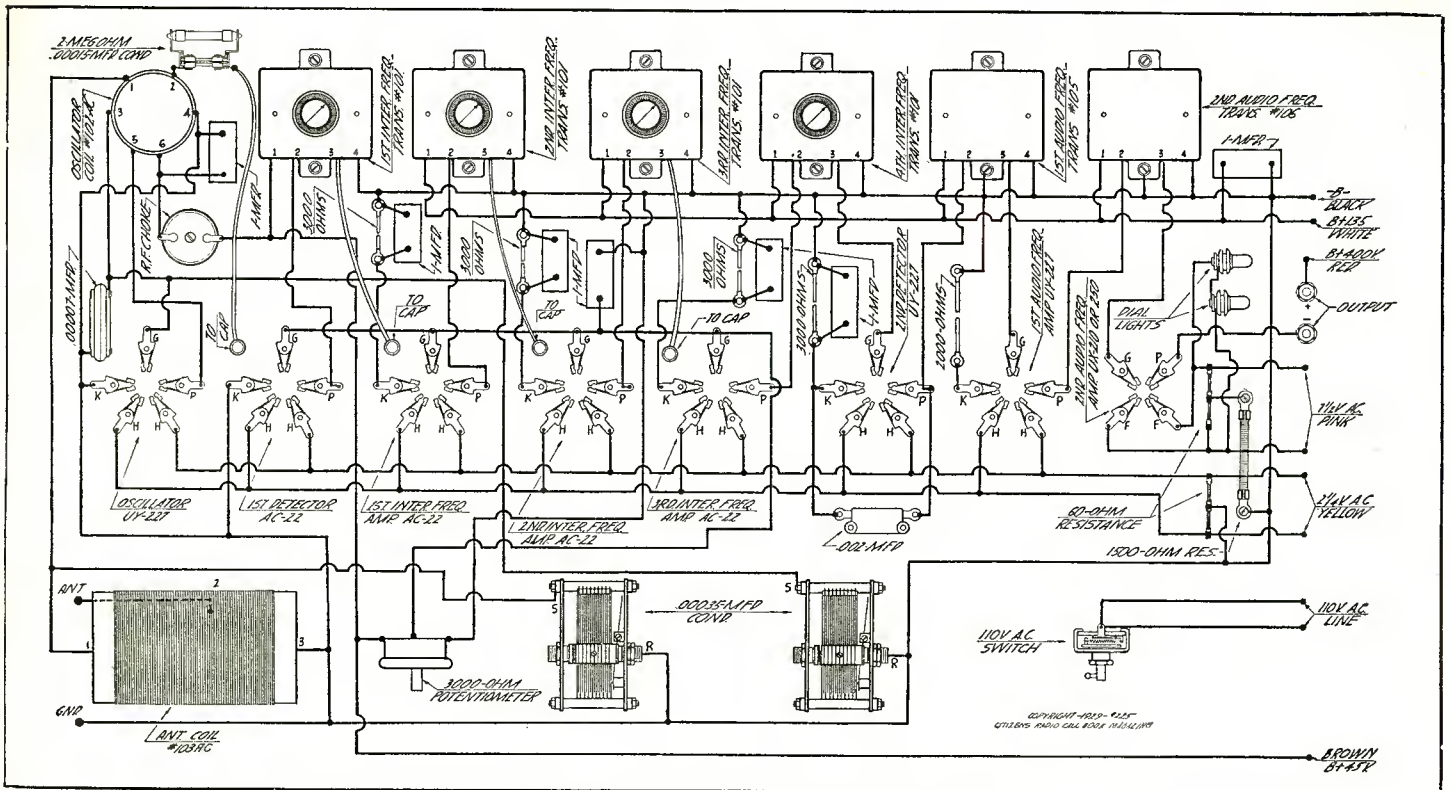

Fig. 2. On account of its form of layout, it would appear that the super is one of the simplest to assemble and wire up that has yet been designed

past experience with this type of audio has proven its excellent worth in reproducing the full frequency of the musical range correctly, and with a higher gain than is found in many high priced transformers.

An output transformer—Lincoln No. 107—may be mounted at the right hand side of base when the Hollister AC-8 is used with a speaker not having an output transformer. The output transformer is not included in the standard kit, as the majority of dynamic and magnetic speakers already have an output transformer incorporated in the speaker.

The power equipment for the Hollister AC-8 is a very compact crystalline finished case— $3\frac{3}{8}$ in. wide, $5\frac{1}{2}$ in. high and 16 in. long. This equipment supplies 45 volts, 135 volts and 450 volts B, $7\frac{1}{2}$ volts a. c. and $2\frac{1}{4}$ volts a. c.

The power equipment is very ruggedly made and over a period of one year's experience has not been known to have a broken down condenser or transformer. One 281 type tube is used.

Operation

The operation of the Hollister AC-8 is simplicity itself. Two selector dials are used to insure ease in locating stations when perfect 10 k. c. separation is desired. The two dials track evenly throughout the broadcast range, but where 100 to 300 stations are available in the dial, every degree of the dial is used, and due to the slight variations in variable condenser capacity, two controls with two indicative dials make both input and oscillation setting easily and accurately found and logged.

A single volume control, composed of a 3000 ohm potentiometer controlling the 45 volts applied to the screen grid tubes, is the only other adjustment necessary for tuning.

One degree on the dial repre-

sents about 10 kilocycles. A steady rotation of both dials will tune in station after station with clean separation in every degree with good volume, the higher powered stations within 2,000 miles with pleasing volume.

Similar to the Lincoln 8-80, the Hollister AC-8, over the manufacturer's test of months, has taken its place with its companion receiver as foremost in tremendous power and extreme selectivity and distance getting ability.

Reports of performance of the Lincoln 8-80 receiver, using the Lincoln 101 intermediate transformers, have proved without a doubt that the design of these transformers was absolutely right. Many set builders report the logging of practically every 10 kilocycle band in the broadcast range, and logs of over 300 stations, including many 50 and 100 watt stations 3,000 miles away, which were brought in with good loudspeaker volume, proves that no great improvement could be made. The ability of the No. 101 transformer to produce excellent amplification without oscillation has made this possible.

A fair idea of the selectivity of the Hollister AC-8 can be had by noting the log of a small section of the dial made in a steel and concrete bank building in the heart of Chicago. WPG, 1100 k. c.; KMOX, 1090 k. c.; WMBI, 1080 k. c. (local); WTAM, 1070 k. c.; WBAL, 1060 k. c.; KNX, 1050 k. c.; KRLD, 1040 k. c.; KYW, 1020 k. c. (local).

Tests made in localities in Chicago where powerful equipment had difficulty in getting local stations, equipment using Lincoln 101 transformers brought in stations from the Gulf to the Pacific Coast with good volume.

Stations from the Atlantic to the Pacific Coast were brought into a steel reinforced concrete building through the barrage of Chicago local stations, as well as from fifty to one hundred x-ray and other high tension equipment in many hospitals and medical

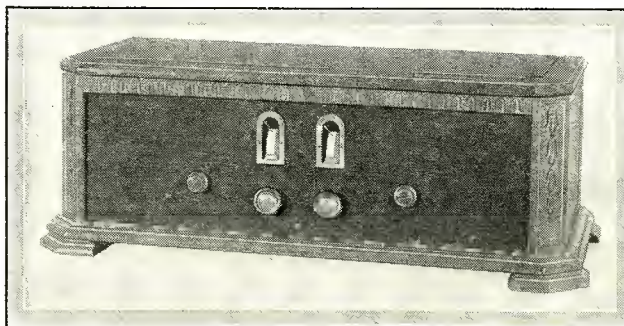

Fig. 3. Completed receiver may be housed in an attractive cabinet as illustrated above, or, if desired, it may be used in a console with its power supply placed below

schools located within two blocks of the location of this receiver. Practically every ten kilocycles in the broadcast range were re-recorded, and with noise level permitting, could be brought up to a volume which was all a dynamic speaker could carry.

Due to the high amplification in the Hollister AC-8, a very short antenna is all that is necessary. Using a 24 inch length of wire for an antenna, PWX, Havana, was played at will from 6:30 o'clock in the evening until 10:30. Stations within the boundaries of the United States could be brought in with considerable volume, and could hardly be told from the Chicago local stations.

Construction

Construction has been simplified to a considerable degree. All units, being in a straight line, are easily mounted, and the wiring simplified by the fact that a big proportion of same is composed of bus-bar leading from one end of the chassis to the other. The bakelite base-board is completely drilled, and mounting of component parts can be done in a few minutes.

Both drum dial and condenser assembly are mounted with four screws in base-board only. All main leads are brought through to a terminal strip mounted underneath one end of the base-board, with desirable soldering connections for attachment of eight lead cable to power pack. This cable is equipped with two extra heavy leads sufficient to carry the 7 heater type tubes used.

Electrical Details

All of the electrical details of the circuit may be readily seen by an examination of the schematic diagram shown in Fig. 4. Energy from the antenna, which may be either indoor or outdoor but necessarily a short one on account of the sensitivity of the set, is fed into the first detector circuit through the antenna coil 103 a. c. Between one end of the input coil and the grid of the screen grid is the pick-up winding of the oscillator coil 102 a. c. Detection is by the conventional .00015 mfd fixed condenser with a 2 megohm grid leak in parallel. The cathode of the screen grid tube is common with the lower extremity of the input coil, ground and B minus.

In the oscillator circuit tuning is across the grid section of the coil by means of a .00035 mfd condenser, which is the one shown at the left in the photograph in Fig. 1. It is at the right of the operator when tuning. The condenser at the operator's left is the antenna input stage. A radio frequency choke located between the regenerative coil of the oscillator and the common B45 line serves to eliminate the possibility of radio frequency energy getting back through common coupling into the plate supply line. This r. f. choke is bypassed with a 1 mfd condenser. The oscillator tube is a 227 type with its cathode common with the rotor of the tuning condenser, one end of the grid coil and ground.

In the intermediate stages, the first detector feeds through the 101 tunable intermediate into the grid circuit of the first intermediate frequency tube, which is an a. c. 22. Tuning of the first, second, third and fourth intermediate frequency transformers is

possible by means of the small variable condensers contained within the housing, the knob coming through at the top of the can, as shown in the photograph, Fig. 1. This tuning is across the primaries of each of the intermediate frequency transformers.

Bias for the grids of each a. c. 22 used in the intermediate stages is secured by the drop across individual 3000 ohm fixed resistances located between the lower terminal of the secondaries (which are common with ground) and the cathode. Each of the 3000 ohm resistances are bypassed by a 1 mfd condenser. This insures individual grid bias on the tubes and at the same time considerably stabilizes the receiver's operation.

The 3000 ohm potentiometer having volume and sensitivity control is located between B minus and B plus 45 terminals, the center arm leading to the screen grids of the first detector and the first three intermediate stages. The center arm is also bypassed to ground with a 1 mfd condenser.

The second detector circuit makes use of a resistance drop for securing the necessary bias for detection, so that no grid leak and condenser are required in that stage. Here a 227 is also used as a detector.

The first and second audio stages employ the well known Clough transformer idea, the first stage using a 227 and the last stage either a 210 or 250, depending on the desire of the operator.

The bias for the grid of the first audio is secured through the drop across a 2000 ohm resistance between terminal four of the secondary and the cathode. The bias for the 210 or 250 is taken through the drop across a 1500 ohm resistor lying between terminal four of the 106 second audio transformer and the center of a 60 ohm center tapped resistance across the 7.5 volt a. c. filament supply. The dial lamps are placed in series across the 7.5 volt line. The switch on the receiver, which is located at the operator's extreme right, is in series with 110 volt a. c. line. The 3000 ohm potentiometer used for volume and sensitivity is at the operator's extreme left. The use of an input transformer has been mentioned previously in this article, but is not shown in the schematic because all of the dynamic speakers at present employ an input transformer. Thus, the operator of the set is not required to purchase additional material.

Official Parts List

Below are shown the parts required for construction of the Hollister AC-8:

- 1 Lincoln No. 102 a. c. Oscillator.
- 1 Lincoln No. 103 a. c. Antenna.
- 4 Lincoln No. 101 i. f. Transformers.
- 1 Lincoln No. 105 Audio Transformer.
- 1 Lincoln No. 106 Audio Transformer.
- 2 Precise .00035 Condensers.
- 1 Sub-base and Socket Assembly Completely Drilled.
- 2 Sub-base Supports.
- 2 Illuminated Drum Dials and Windows.

(Continued on page 118)

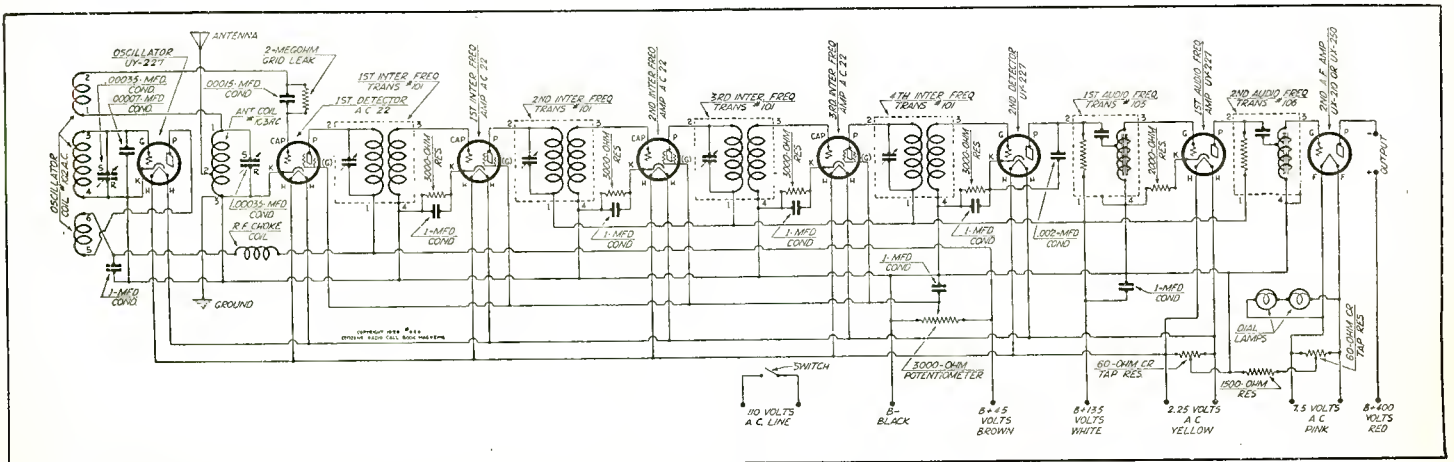

Fig. 4. The schematic circuit used in the Hollister AC-8 may be learned by referring to the drawing above

Simple Wave Trap Will Be a Help in Eliminating Interference

Variety of Circuit Combinations Possible With Hook-up Shown in Accompanying Article

EVER since radio became popular with the experimenter as well as the fan, certain types of interference have been encountered by users of radio sets. In many instances, these cases of interference could have been obviated by the simple expedient of trapping out the interfering frequency provided that such frequency was not too close to the frequency of the signal desired. Even in the early days of the art, wave traps have been known and used, and if at that time there was justification for their employment, the same can be said of the present day, especially where there has been a tremendous increase in number and type of electrically operated devices other than radio ones. Many electrical devices which have given interference will be found to create such an interference over a relatively limited band, and in many cases this interference may be absorbed by the use of a wave trap.

Efficiency and Versatility

The degree of success achieved through the employment of a wave trap depends largely on two factors. The first is the efficiency of the trap itself and all related parts, and the second is the versatility of the experimenter in employing this circuit for the reduction or perhaps elimination of interference.

The wave trap described in this article is shown photographically in Fig. 1, where it will be seen to consist of an inductance, a socket for the inductance, a variable condenser and four binding posts, two of these being in the input circuit and two in the output circuit. The schematic diagram shown in Fig. 2 gives an idea of the input circuit, which is the primary in the coil, while the output circuit is the secondary of the coil, this latter inductance being tuned by a .00035 mfd variable condenser. With these two simple inductance symbols, the experimenter having had any experience whatever in radio can readily imagine the number of interesting and possibly useful combinations that may be worked out by the proper placement of the inductances in a circuit. Most of the uses for which this wave trap can be employed are shown in this article, these being Figs. 3, 4, 6 and 7. In addition to these uses shown in these schematic sketches, there is another use which can be described in the text, but for which a diagram was not considered necessary.

Helps On Supers

For example: the owner of a super-

heterodyne using a loop may find on occasion that the loop stage is quite broad. One of the methods in which the broadness of tuning may be cured to a certain extent by means of the simple trap, the diagram of which is shown in Fig. 2, is to place the winding P and F1 in series with the center tap of the loop, and leave the winding G and F2 spanned by the variable capacity alone. Then the receiver may be tuned in the usual manner and after the broad signal is encountered on the loop dial, the condenser of the wave trap may be rotated back and forth across this interfering signal until some of the disturbing noise is absorbed by the tuning circuit in the wave trap. The foregoing description, of course, applies to the super in which a center tapped loop is used. In the event that the center tapped type is not employed, it is possible to place the primary of the wave trap in series with the grid return of the loop, which is the wire going to the filament. In placing the wave trap primary in this position, it is advisable to place the connection between the center tap and the filament, or between the filament and the grid return in such a way that the primary winding is not included in the tuned portion of the loop circuit. While this method of absorption tuning for getting rid of interference may involve an extra control, nevertheless there are occasions when its use might be warranted.

Varied Uses

In addition to the use to which the wave trap may be put in a superheterodyne, there are the many forms of connection shown diagrammatically in this article. For example: in the sketch shown in Fig. 3 it will be seen that the primary of the wave trap is not used. The secondary, however, is employed, with one terminal of the wave trap going to the antenna and the other terminal to the antenna post on the receiver in operation. This type of connection may be used regardless of whether the job is a super with an antenna pick-up coil, or whether it is an ordinary tuned r. f., or even if it is a regenerative set. The ground on the receiver is not changed. With the trap and the receiver hooked up as shown in this sketch, it will be seen that the secondary inductance is, therefore, in series with the antenna of the receiver. By such an arrangement, the receiver itself may be tuned to a desired station and the dial of the wave trap rotated until any interference experienced on that particular wave length is partly ab-

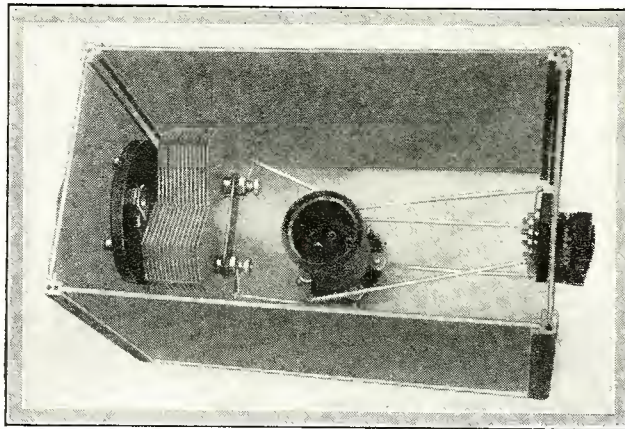

Fig. 1. In this photograph may be seen the simple wave trap after it has been fully constructed and placed inside of an aluminum shielding can. The input and output binding posts are shown at the right in the photograph

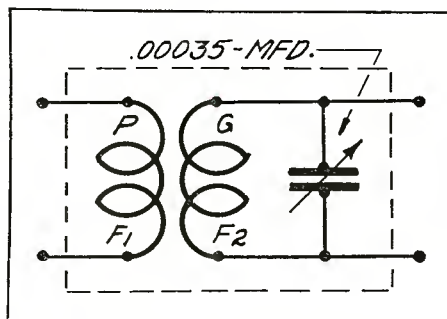

Fig. 2. The schematic circuit of the wave trap is shown in the illustration above. It consists merely of a primary and secondary winding on a tube, the latter winding being tuned

(This wave trap designed, tested and all illustrations made in our laboratory)

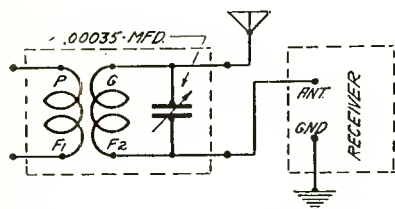
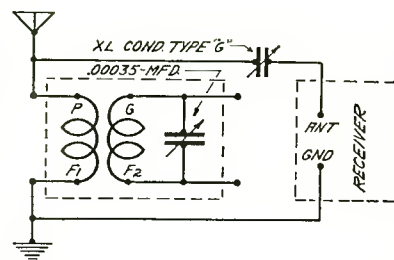

Fig. 3. At the left is shown one of the many combinations possible by means of the wave trap used in conjunction with a receiver for the elimination of interference on the broadcast band

Fig. 4. Another interesting circuit arrangement involving the use of a wave trap and a small condenser, such as the X-L, is shown in the schematic at the right



sorbed or rejected by the trap circuit. Although such a trap is quite useful in many cases, nevertheless the experimenter cannot expect too much of its use. Thus he should not expect to eliminate a heterodyne note from an incoming signal by means of this trap because the heterodyne note would be on almost exactly the same frequency that is being received by the receiver. However, if another station ten kilocycles away were operated, and there was a likelihood of interference between the two, some of this interference may be absorbed by the tuned trap circuit.

Another interesting method of connection is that employed in Fig. 4, where it will be noted that the primary of the coil is used, with one extremity going to the antenna and one side of an X-L type G condenser. The other side of the antenna coil goes to the ground and to the common ground of the set. The antenna post on the receiver itself is connected to the other side of the X-L condenser so that the receiver itself is capacitatively coupled to the antenna. Then the secondary circuit of the wave trap is left without being connected to anything. In this fashion the secondary circuit which is tuned by the variable condenser acts as an absorbing circuit. A simple explanation of this particular wave trap combination might be stated as follows:

After proper manipulation of the X-L type G condenser, in order to get maximum signal strength from the antenna, the receiver itself is tuned to a desired signal. An interfering signal at approximately the frequency of the desired signal may then be trapped by means of the secondary condenser, which is inductively coupled to the primary. The undesired signal goes down through the primary winding to ground, having been assisted in that direction by the tuning of the secondary circuit while the desired signal is said to be going through the little midget condenser into the antenna circuit of the receiver proper. The diagram shown in Fig. 4 and the one in Fig. 3 are two of the most popular methods of hooking up a wave trap.

Two other fashions in which this may be done are shown in Figs. 6 and 7. In the former the antenna goes through the primary of the wave trap to ground, while the secondary of the wave trap is placed in parallel to the antenna and ground of the receiver proper. While this is not as efficient a method of connection as the preceding one, nevertheless it might be tried with interest by the experimenter.

In the case of the circuit arrangement shown in Fig. 7, it will be seen that this is a variant of the schematic shown in Fig. 4, except that the coupling to the antenna circuit of the receiver is an inductive one in part and a magnetic one in part. In the previous sketch, Fig. 4, the coupling to the receiver itself is a capacitive one. While looking at Fig. 7 it will be seen that

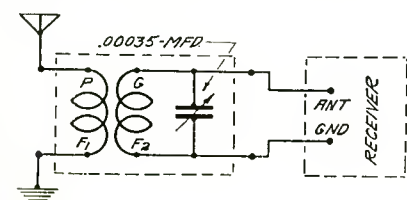

Fig. 6. This is still another method of connecting a wave trap and a receiver, although it is not as efficient as some of the previous methods mentioned. However, it may be tried by the experimenter if he wishes

the antenna goes to one terminal of the primary coil and to one terminal of the secondary. The other terminal of the antenna coil goes to ground, while the extra terminal of the secondary goes to the antenna circuit of the receiver, the latter being grounded. The two arrangements shown in Figs. 6 and 7 are presented herewith not for their efficiency, but merely for their diversity. Of the sketches shown perhaps Figs. 3 and 4 will give the best results for all-around purposes, although if the experimenter is at all interested in playing with a wave trap it might not be a bad idea to try a combination such as Figs. 6 and 7.

Aside from the trim appearance of the wave trap when it is placed inside of an aluminum can, there is still another advantage which might be considered helpful. That is the fact that the aluminum can acts as a shield for the inductance which is located inside. This might not be so noticeably beneficial on long distance reception work, although when used in close proximity to broadcasting the shielding might be of some help. Another feature of the unit shown is the fact that by virtue of the Remler twin-rotor condenser, the secondary inductance does not become grounded in any way. Silver-Marshall plug-in coils are used for covering different bands.

In the construction of the strip which carries the four binding posts, it is a good plan to make this strip out of Formica and then bore four holes in the rear partition of the can, making the holes over-sized so that the binding posts will stick through when the strip is placed in position. This strip is bolted at the top and bottom ends to hold it in position. The dial used on the wave trap may be any 4 inch dial, but since the Remler condenser is used, it is suggested that a dial be secured having the same number of degrees on its face as the travel of the condenser itself.

Official Parts List

Parts required for the construction of the wave trap are shown as follows:

- 1 638 Remler .00035 variable condenser
- 1 Silver-Marshall 131 X or Y r. f. transformer
- 5 Eby binding posts
- 1 Benjamin 9036 four-prong socket
- 1 Aluminum Co. of America shield
- 1 Package Corwico Braidite hook-up wire
- 1 Package Kester radio solder
- 1 Kurz Kash 4-inch dial

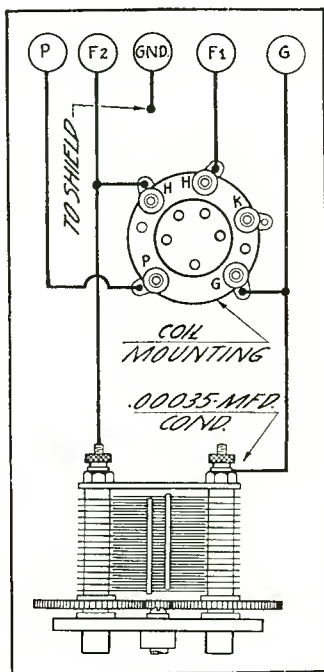
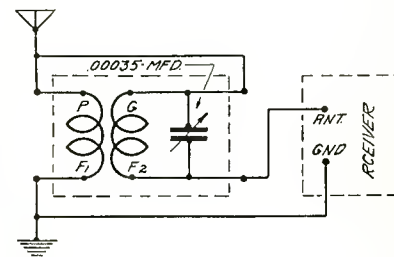

Fig. 5. In the above graphic diagram may be seen the manner of connecting the coil and condenser together. It should be observed that the K terminal in the drawing is not used. It corresponds to the K prong on the Silver-Marshall plug-in coil, which is also not used

Fig. 7. At the right is shown still another method of combining a wave trap and a receiver by means of cutting out undesired interference on broadcast or other wave lengths



Tube Tester Made for Professional Set Builder's Laboratory

Characteristics of Various Tubes May Be Determined by Using Outfit Herein Described

IN keeping with our policy of designing and presenting material for the professional set builder's use in his workshop or laboratory, we take pleasure in showing in the accompanying article how to build a tube tester, by means of which the characteristics of practically all of the tubes now on the market may be ascertained.

In addition to the photographs and the schematic circuit of the tube tester, there are also shown five graphs representing as many characteristics and a handy chart or guide for the operator making such tests, so that all conditions required in this work may be identical for every test that is made.

The vacuum tube characteristic tester, illustrated photographically in Fig. 1 and schematically in Fig. 9, comprises five meters, three of which have switches mounted directly below them, two voltmeter multiplying series resistances and one a milliammeter shunt. In addition there are four tube sockets, a filament rheostat, grid control potentiometer and four switches to obtain the various circuit changes required. The plate voltmeter 0-100 has a series resistance to increase the range to 0-200. The plate milliammeter has a shunt to increase the range from 0-15 to 0-30. The scale of the grid voltmeter minus 10 zero plus 10 is similarly increased by a series resistance to a minus 50 zero plus 50.

The four sockets on the tube tester arc, one for the a. c. and d. c. four-prong tube, one for the d. c. screen grid tube, one for the a. c. screen grid tube and one for the a. c. five-prong tube. The chart shown in Fig. 3 indicates into which socket the tube under test is to be plugged. Wiring of the tester is quite simple if the schematic shown in Fig. 9 is followed. After all of the wires have been put in and the wiring carefully checked, cabling may be employed by means of wax thread or string. The tester has been mounted in a cabinet so that the panel is on a slant. This makes operation less tiresome than if it were horizontal.

In the selection of resistances as voltmeter multipliers Ectrad wire wound resistances were selected inasmuch as the taps on these may be very readily changed to get the exact resistance to match the calibration of the plate voltmeter multiplier. This may be done in the following manner:

The voltage is connected to the B plus binding post of some voltage higher than 50, say 80 volts. Then the voltmeter multiplier switch is turned to the 200 scale, the resistance is adjusted so that the reading will be 40. Inasmuch as the multiplier ratio is 2 to 1, this calibration point may be set at either a higher or a lower voltage and the calibration checked. The clip on the end

of the resistance which has been moved should then be tightened and the calibration will then be permanent. The readings on the 200 volt scale will be equal to twice the voltage indicated on the voltmeter. This will indicate the impressed voltage on the plate of the tube. In the calibration of the grid voltmeter, a similar operation is performed, by impressing a voltage of say 10 volts and then throwing the multiplier switch to 50 volts. The multiplier should then be adjusted so that the voltmeter reads 2 volts. This multiplier ratio is 5 to 1. The calibration point may be checked with a lower voltage say 5 volts and when the multiplier switch is thrown, the voltmeter should read 1 volt. After this calibration point has been determined, the clip on the end of the resistance which has been moved should then be tightened and the calibration will be permanent.

A 2 ohm shunt resistance for the milliammeter should give approximately a 2 to 1 ratio. However, it will be necessary that the fixed resistance be exactly two ohms so that when the milliammeter is used on the 30 mil scale, that the range will follow that of a 15 milliamper scale.

We believe that it would be advisable, in order for the operator to become familiar with the tester, to make the measurement on a 201-A tube in the same manner as we have illustrated the tables and diagrams in the article. Of course, it will not be possible to exactly duplicate these measurements inasmuch as there are no two 201-A tubes alike, but the measurements should come somewhat close.

From the readings of these meters observed under various conditions calculations may be made. These calculations may be used to plot curves on a graph showing the different characteristics.

As an example of how the tester is used, to find plate impedance, amplification constant or factor, and mutual conductance, the complete experiment, formulas, calculations and graphs of a 201-A tube as worked out in our laboratory are given herewith.

Table I

E_p	—Plate voltage (—A to plate) in volts
I_p	—Plate current (plate to fil.) in milliamperes
i_p	—Plate current (plate to fil.) in amperes
E_g	—Grid voltage (—A to grid) in volts
E_f	—Filament voltage in volts
E_{sg}	—Screen grid voltage (—A to S. G.) in volts
r_p	—Plate resistance (DC) in ohms
R_p	—Plate impedance (AC) in ohms
μ	—Amplification constant or factor
g_m	—Mutual conductance in mhms
G_m	—Mutual conductance in micromhos

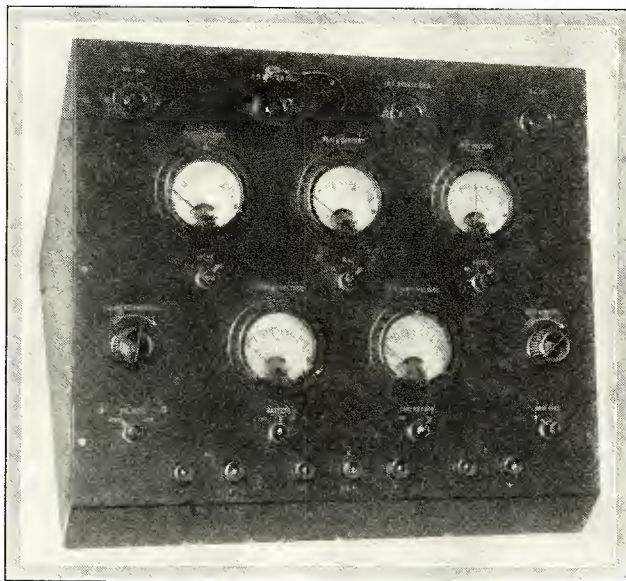

Fig. 1. In this photograph is shown the completed tube tester, placed in an appropriate housing so that the front panel slopes. If desired, the panel might be placed in a square box so that its face would be flat, although the form shown in this photograph seems more satisfactory for average purposes

(This tester designed, tested and all illustrations made in our laboratory)



Fig. 2. In the graph is shown an E_g-I_p curve of a 199 tube. By examining the graph, it will be noted that from 0 to 10 negative E_g the I_p makes a decided rise and from 10 plus up the current I_p increases very little with a large increase of E_g . This is called saturation. That means the filament is emitting all the electrons possible, making the space between the plate and filament saturated

From these values the graph illustrated in Fig. 7 was plotted showing the plate resistance varying with plate voltage.

Table III

E_p	i_p	r_p	$\frac{1}{2}r_p$ or R_p
22.5 ÷ .0004 =	56,250.0	28,125.0	
45. ÷ .0016 =	28,125.0	14,062.5	
67.5 ÷ .0038 =	17,763.1	8,881.55	
90. ÷ .0067 =	13,432.8	6,716.4	
135. ÷ .0137 =	9,854.0	4,927.0	

The amplification factor of a tube varies only a little so one value of μ is accurate enough for all calculations.

$$\mu = \frac{E_{p1} - E_{p2}}{E_{g1} - E_{g2}} \text{ when } I_p \text{ is constant}$$

A plate voltage and grid voltage was applied to the tube and the I_p noted. The plate voltage was lowered and the grid voltage was then changed by the grid control potentiometer until I_p was the same as the original reading. The first and second plate voltages and grid voltages were recorded as shown below.

Table IV

$E_{p1} = 110$	$E_{g1} = 8.6$	$I_p = 1.5$
$E_{p2} = 70$	$E_{g2} = 3.6$	$I_p = 1.5$
$E_p = 40$	$E_g = 5.0$	

TUBE	E_f	FIL. RES.	'A' BATT.	SOCKET	AMP. RET.	DET. RET.	'C' BATTERY	'B' MAX.
112-A	5	HIGH	6	DC-AC	A-	A+	-4.5 TO -10.5	135
199	3	"	4	DC-AC	"	A+	0 TO -4.5	90
200-A	5	"	6	DC-AC	"	A-		45
201-A	5	"	6	DC-AC	"	A+	0 TO -9	135
222	3.3	"	4	DC-SG	"		R.F. 0 TO -1.5, S.G. +22.5 TO +45	135
222	3.3	"	4	DC-SG	"		A.F. +22.5, S.G. 0 TO -1.5	180
226	1.5	"	2	DC-AC	"		6 TO -13.5	180
227	2.5	LOW	4	AC-DET.	"	C	0 TO -9	90
240	5	HIGH	6	DC-AC	"	A+	0 TO -3	180
120	3	"	4	DC-AC	"		-22.5	135
171-A	5	"	6	DC-AC	"		-40.5	180
AC-22	2.5	LOW	4	AC-SG	"		R.F. 0 TO -1.5, S.G. +22.5 TO +45	135
AC-22	2.5	"	4	AC-SG	"		A.F. +22.5, S.G. 0 TO -1.5	180

Fig. 3. The chart illustrated above is a guide to show the professional set builder what connections, voltages, etc., are used when various tubes are being tested by means of the tester described in this article. The chart is self-explanatory and takes into consideration the different types of tubes which may be tested by this outfit

The grid control potentiometer was turned to the left as far as possible. Referring to the chart shown in Fig. 3, the following was done; 6 volt storage battery was connected to the A terminals, a 22.5 volt B battery was connected to the B binding posts and 45 volts to the C posts. The tube was inserted in the D. C.-A. C. socket and the grid return switch was turned to A minus, filament resistance switch to high and the filament rheostat turned to the right until the voltage of E_f was five, as shown on the filament voltmeter. Then various readings of plate current (I_p) were taken at different B voltages and recorded as follows:

Table II

E_p	I_p	E_g
22.5	.4	0
45.0	1.6	0
67.5	3.8	0
90.0	6.7	0
135.0	13.7	0

From these figures, the characteristic curve of plate current varying with plate voltage was plotted, as is illustrated in Fig. 4. By applying the formula

$$r_p = \frac{E_p}{i_p}$$

the d. c. plate resistance was found for that voltage. The AC plate resistance or impedance is equal to approximately one-half of the DC plate resistance. Therefore $R_p = \frac{1}{2}r_p$.

$$E_p \div E_g = \mu \quad 40 \div 5 = 8 \quad \mu = 8$$

Applying the formula $\mu = \frac{E_p}{R_p}$, the operator obtains the mutual

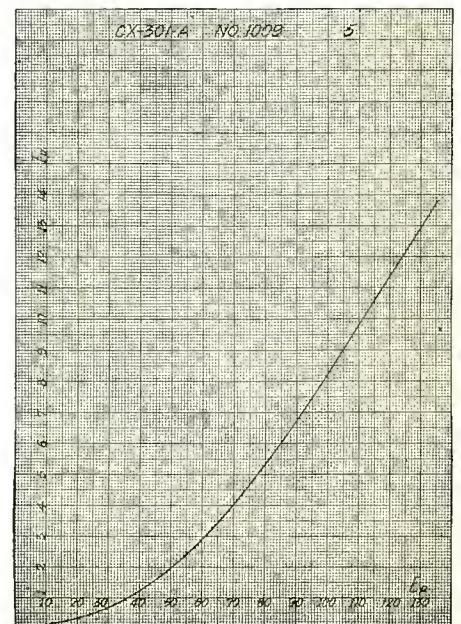

Fig. 4. Various readings of plate current at different plate voltages are taken and from these figures the characteristic curve of plate current varying with plate voltage is plotted. The method of making a graph is described in the accompanying text

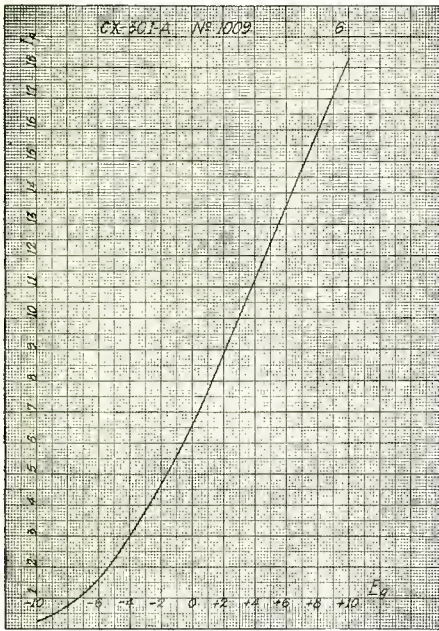

Fig. 5. By varying the grid voltage from positive to zero to negative and then recording the plate current at various points, a graph may be made similar to the one shown which illustrates the plate current—grid voltage characteristic of a 201-A tube

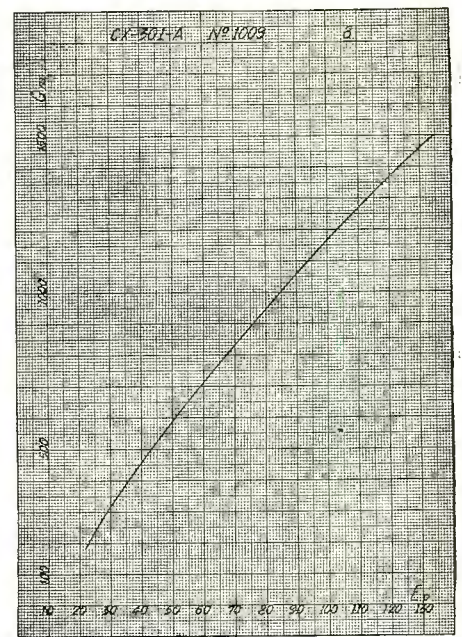

Fig. 8. In the graph shown herewith the operator has plotted the change in mutual conductance of a tube in accordance with the change in plate voltage. The method of plotting this graph is also described in the text accompanying the article

conductance. $G_m = g_m \text{ times } 10^6 \text{ (1,000,000)}$.

Table V

E_p	μ	R_p	g_{mmhos}	micromhos
22.5	$8 \div 28,125 = .0002843$			284.3
45.0	$8 \div 14,063 = .0005687$			568.7
67.5	$8 \div 8,882 = .0009007$			900.7
90.0	$8 \div 6,716 = .0011925$			1192.5
135.0	$8 \div 4,927 = .0016238$			1623.8

From these figures of G_m , a graph was made, Fig. 8, showing the change in G_m with changes in E_p .

By varying the grid voltage from plus to zero to minus and recording the plate current at various points, the graph may be made such as the one illustrated in Fig. 5, showing the plate current—grid voltage characteristic of a tube.

Graph Shows Saturation

In Fig. 2 is shown an E_s-I_p curve of a 199 tube. It will be noted that from zero to 10 minus E_s , the I_p makes a decided increase and from zero to plus 20 the current I_p increases very

little with large increases of E_s . This is called the saturation point; that is, the filament is emitting all electrons possible for the same value of E_p , making the space between the plate and the filament saturated. This also explains why so many individuals secure poor results from 199 tubes, which they are overloading. Any tube will saturate, but the 199 tubes saturate the easiest. The saturation point of other tubes may be ascertained by the operator, if he so desires, by following the method outlined for testing under Fig. 2.

Official Parts List

Parts required for the construction of the tube tester described in this article are shown below:

- 2 301 Weston 0-100 volt voltmeters
- 1 301 Weston 10-0-10 voltmeter
- 1 301 Weston 0-7 voltmeter
- 1 301 Weston 0-15 milliammeter
- 1 V-200 Electrad 20,000 ohm fixed resistance
- 1 B-50 Electrad 5000 ohm fixed resistance
- 1 H $\frac{2}{3}$ Carter $\frac{2}{3}$ ohm fixed resistance
- 1 H2 Carter 2 ohm resistance
- 1 HW20 Carter 20 ohm rheostat
- 1 52000P Yaxley 2000 ohm potentiometer

(Continued on page 112)

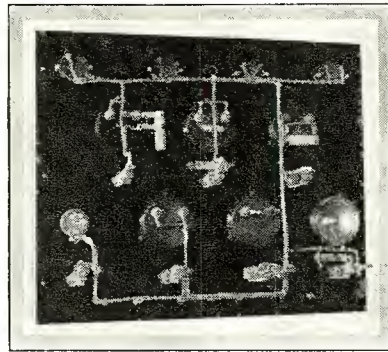

Fig. 6. This photograph shows a rear view of the tube tester after all of the wiring has been put in and properly cabled

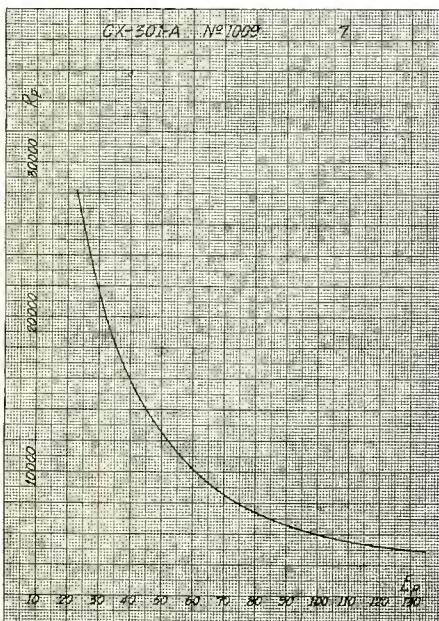

Fig. 7. Variation of plate resistance during changes of plate voltage is illustrated in the graph shown. In determining the values necessary to make up the graph shown, a formula is required to find the d. c. plate resistance, the a. c. resistance for all general purposes being considered a half of the d. c. resistance

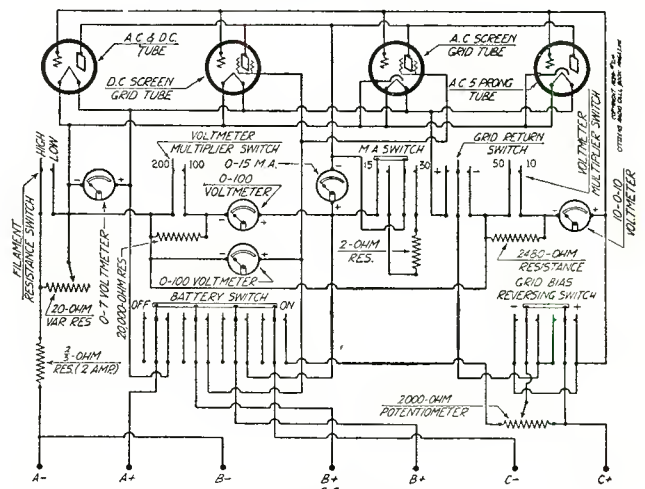

Fig. 9. The schematic circuit involved in the tube tester is shown above

Simple D. C. Eliminator and Charger Is Made from Spare Parts

Many Residents in Direct Current Districts May Find This a Labor Saving Device

SURPRISING as it may seem, there are a large number of broadcast listeners who reside in direct current districts who are still under the impression that it is necessary to pack up their battery and lug it over to a service station to have it charged every time it runs down. This condition seems to exist principally due to the belief on the part of the listener that inasmuch as he is in a direct current neighborhood he can't charge his battery. Many listeners are capable of understanding how they could run a rectifier and charge their battery if living in an alternating current district, but apparently are not able to see the method whereby the same thing can be accomplished in a direct current district.

There have been enough inquiries received on this subject recently by our Information Department to make it advisable to include in this article a brief description of the device itself, which was suggested by A. G. Miller of Monroe, Mich.

For Charging or Plate Potential

The schematic circuit in Fig. 2 shows the electrical connections of the eliminator. A three-pole double throw switch enables the unit to be switched in one direction as a means of charging the A battery through a 75 watt lamp and when the switch is thrown in the opposite direction, the 110 volt line is passed on to the receiver through a suitable choke and a voltage divider system. The choke consists of an old audio transformer connected as shown in the schematic, and an 8,000 ohm resistance with a center tap placed across the plus and minus of the 110 volt line, so as to give 45 volts at the mid point. In operation, the filament switch in the receiver is left in the "on" position permanently and the unit controlled by means of the three-pole double throw

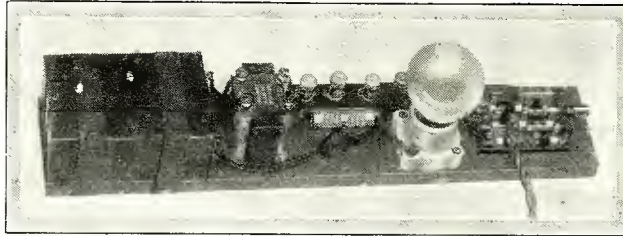

Fig. 1. The combined d. c. B eliminator and battery charger is shown in the photograph above

switch. It would be advisable in connecting up the unit to make sure that the plug that goes into the 110 volt d. c. line is properly poled. If necessary, a polarity plug may be secured, so that there will be no possibility of the plug being placed in the reverse manner.

In the operation of the unit, if any hum is encountered, it may be necessary to take out the connection between the G and F terminals of the audio transformer, although in 99 cases out of 100, this will not be necessary. When the device is used as a charger, the 75-watt lamp governs the amount of current being fed into the battery. For all-around purposes, the 75 watt lamp will suffice and the unit may be left on at all times that the receiver is not in operation.

Official Parts List

Parts required for the combined d. c. eliminator and battery charger are shown below:

- 1 Three-pole double throw switch
- 1 Porcelain lamp socket
- 3 Dubilier 2 mfd 200 volt condensers
- 1 Thordarson R-152 audio transformer
- 1 Electrad B-80 8,000 ohm center tapped Truvolt resistor
- 4 X-L binding posts
- 1 Formica binding post strip
- 1 Wood baseboard
- 1 Package Kester radio solder
- 1 Package Corwico Braidite hook-up wire

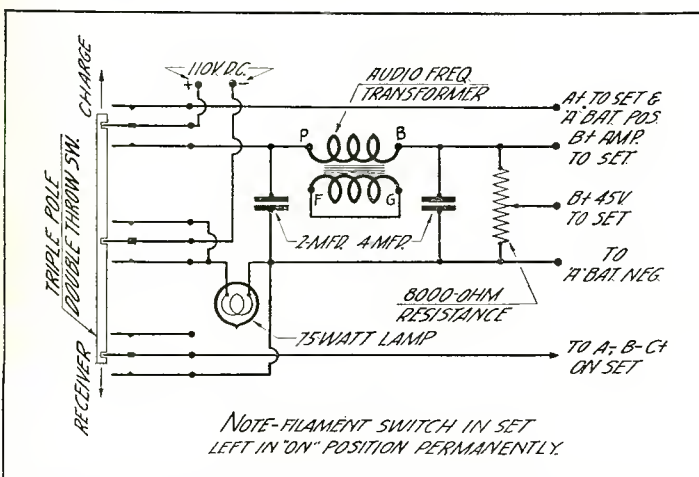

Fig. 2. This schematic circuit shows the electrical connections in the combined B eliminator and A battery charger

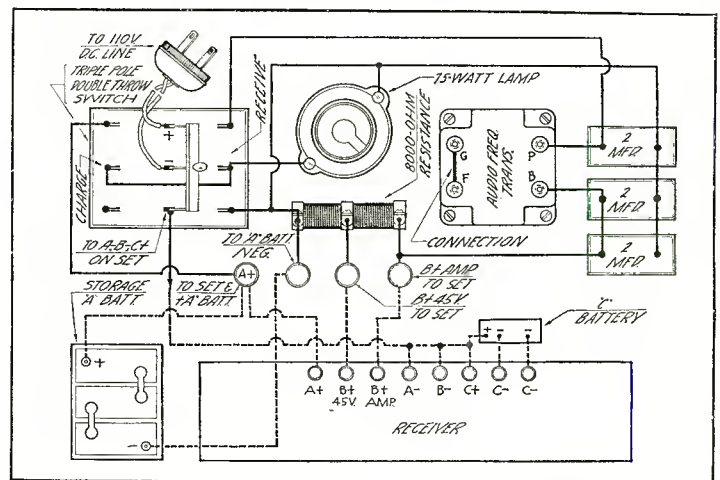
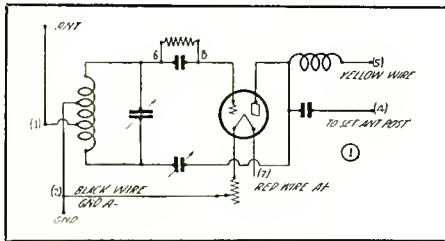

Fig. 3. The unit may be wired up from the graphic diagram shown in the above illustration. The receiver is shown in the bottom portion of this diagram and may be any small receiver requiring not more than 110 volts on the plates of its tubes

(This eliminator designed, and all illustrations made in our laboratory)

Many Combinations Possible with the New Walker Multi-Unit

Short Wave Converter, Long or Short Wave Oscillator, R. F. Booster Few of Possible Circuits



enue, Cleveland, Ohio, in answer to the demand for a flexible, single tube outfit which can be put to a multitude of uses.

What It Does

The unit will function as a regular receiver, and by changing the plug-in coil short wave stations may be heard. Attaching the unit to a receiver as an extra stage of tuned radio frequency will permit greater volume, distance and selectivity. When plugged into the socket of a receiver, the audio amplifier is utilized and greater volume results when tuning in a short wave station. Its use as an audio oscillator will permit the radio service man to set up a signal when repairing a receiver to determine whether the set is in operating condition. It is also possible to use the set as an efficient crystal detector. One of the features of the Multi-Unit is that almost any standard type of tube may be used, such as 226, 201-A, 199, 112-A, WD-12, 200-A, 222 screen grid, etc.

In the accompanying article there are thirteen possible combinations which may be made by use of the Multi-Unit, although other combinations may suggest themselves to the experimenter or set builder.

Each of the small schematics printed with this article bears a reference number within a circle, this number being the number of the possible combination.

For example: the diagram in No. 1 shows the unit used as an extra stage of tuned radio frequency. sometimes known as a booster stage. The 199, 201-A, 112-A type tubes in the d.c. receiver are the ones that may be used in this particular layout. Instructions for

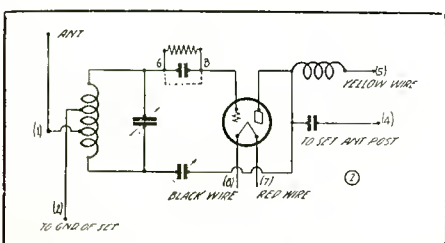

EXPERIMENTERS as well as professional set builders will be interested in the recent announcement of the Multi-Unit designed by the George W. Walker Mfg. Co., 13301 Durkee Av-

securing this combination are: Connect red wire of plug to No. 7, black to No. 2, yellow to No. 5; insert tube in socket T; large coil in socket C; remove first r. f. tube from receiver and insert

in proper plug; insert plug in socket in which tube has been removed; disconnect antenna from receiver and fasten to No. 1. Connect a wire from No. 4 to antenna post of receiver. When the unit is used with a receiver employing 199 tubes, the control

FIL is set at position 3. When 6 volt tubes are employed, the entire control of FIL may be made. The use of a 112-A tube will be found very efficient.

When using the circuit as an extra stage of tuned r. f. in connection with a type 226 tube in the r. f. circuit, as shown in No. 2, the instructions are: Connect red wire of plug to No. 7, black to No. 8, yellow to No. 5; insert tube in socket T; large coil in socket C; remove first r. f. tube from receiver and insert in adapter plug; insert plug in socket from which tube has been removed; disconnect antenna and fasten to No. 1. FIL is set at zero position and should not be used. Connect a wire from No. 4 to antenna post of receiver. Should the receiver employ an antenna coil not of the inductively coupled type, connect a wire between No. 2 and the ground of the receiver.

If the experimenter desires a screen grid r. f. amplifier using the 222 type tubes, d. c., (No. 3) he should remove the grid leak and fixed condenser from the unit. Connect red wire of plug to No. 7, black to No. 2, yellow to No. 5, and green to No. 4. Connect a wire from B plus 45 to terminal B of unit. When this is not convenient, connect a short wire between No. 6 and B of unit. Fasten short wire with clips to G. Insert 222 tube in

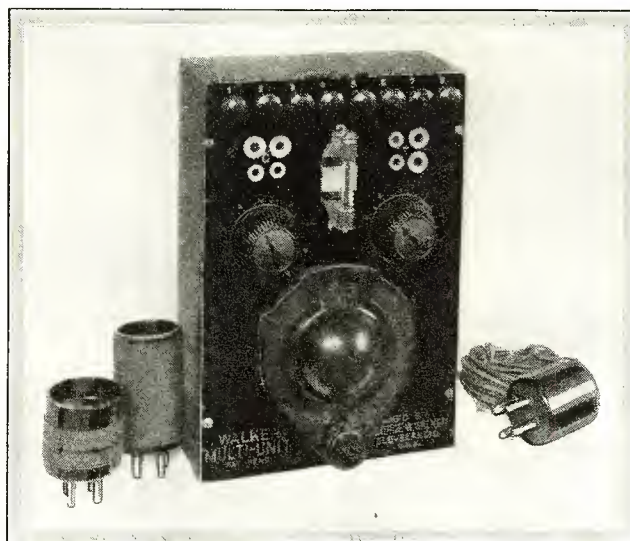
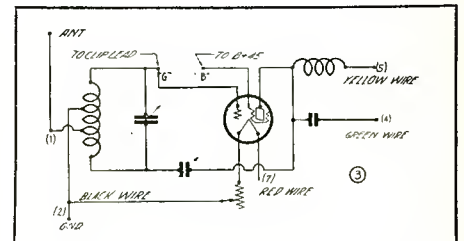
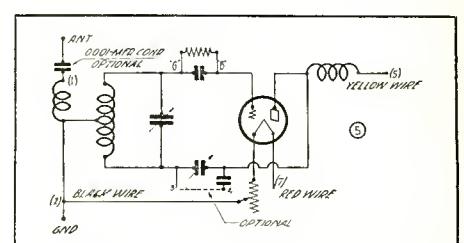
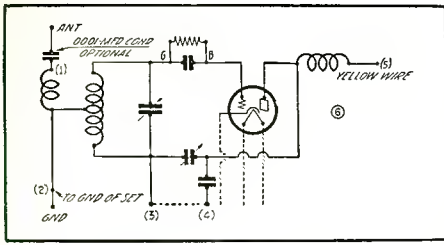

Fig. 4. This photograph shows the Walker Multi-Unit described in the accompanying article by means of which circuit many variations may be made by the experimenter

(This unit tested and all illustrations made in our laboratory)





connect antenna from receiver and fasten to No. 1. The ground wire remains connected to receiver unless your antenna coil is of the inductively coupled type, that is, the primary winding is separate from the secondary and makes no direct wire connection with each other. With antenna coil inductively coupled, the ground wire is connected to No. 2 along with the black wire. The green wire is disconnected and a connection is made between the antenna post of the receiver and No. 4 of unit. Another wire is connected from the ground post of receiver to either plus B90, or to No. 6 of unit, whichever is best. Set FIL at 3. Do not increase beyond this point, as damage to the tubes may result. Set VOL at about .4. Turn on the receiver and tune in a station in the usual way, rotating the dial unit until a signal is heard. Readjust the dial of the receiver and unit for clarity. Now adjust the VOL control for volume. The use of the unit with the receiver provides for greater volume and sensitivity. The selectivity when using the 222 type tube is not as great as when the 201-A is used, but the improvement in clarity compensates for this. The VOL control is of the utmost importance. Its use will be appreciated with practice and experience. Various adjustments of this control may be necessary in tuning, as a certain setting may prevent a station from being heard due to

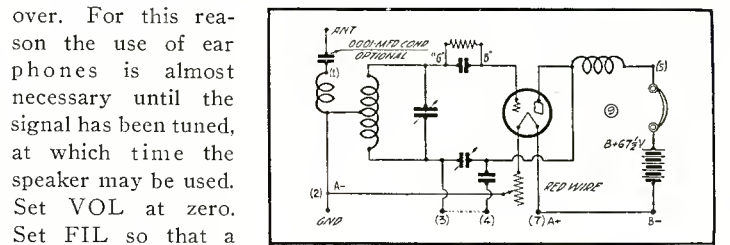

over. For this reason the use of ear phones is almost necessary until the signal has been tuned, at which time the speaker may be used. Set VOL at zero. Set FIL so that a slight hissing noise is heard. This will indicate the tube is oscillating. Rotate the dial slowly, adjusting the FIL so that the hissing is heard with each setting of the dial. When approaching a station, the carrier wave or whistle will be heard. Carefully readjust the dial and FIL until the signal is clear. The proper adjustment of these two controls will prevent body or hand capacity. Due to the sharpness of the station, patience is required in logging the weaker signals. The average aerial is really too long for ideal short wave reception. To compensate for this, the use of the .0001 mfd fixed condenser will help. This may require a slight readjustment of the dial.

Other Uses

When the outfit is used as a short wave adapter, in an a. c. receiver, the connections are those shown in Fig. 6.

Figs. 7, 8 and 9 refer to the use of the set as a single tube receiver, either short or regular broadcast wavelengths.

No. 10 shows the unit as a single dial operated a. c. receiver. No. 11 shows it is a single

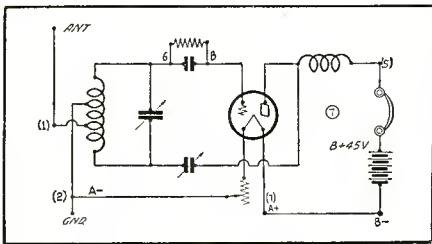

the degree of selectivity which is possible.

Short Wave Adapter

When the unit is used as a short wave adapter, it should be connected as shown in Fig. 5. Here we find the grid leak and condenser remain connected across B and G. Connect the red wire of the plug to No. 7, black to No. 2 yellow to No. 5. Insert small coil in socket C. Remove detector tube from receiver and insert in socket T of unit. Insert plug in detector tube socket of receiver. Connect antenna to No. 1 and ground to No. 2 along with black wire. When using a receiver employing 199 tubes and a 4½ volt A supply, the control FIL is set at the maximum of position 3. With the 6 volt tubes, the entire control of FIL may be made. It has been found that the 200-A or 112-A type has proved more efficient than any other in tuning the short wave stations. As the use of an adapter does not utilize r. f., the r. f. tubes may be removed from the receiver to conserve current. Should the receiver incorporate separate r. f. rheostats the tube may be cut off at that point. The rheostat controlling the detector may be turned to full on position. Operation: Tuning of short wave stations is very sharp and unless the dial of the unit is rotated very slowly, a station may be passed

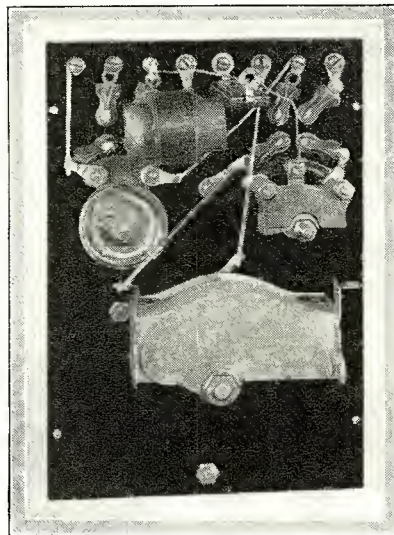
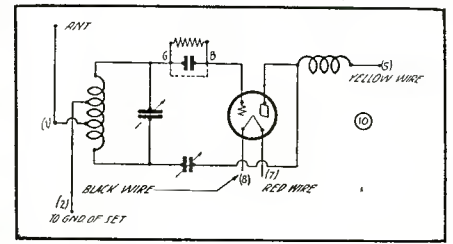

Fig. 13. This photograph shows the rear view of the panel of the unit, which is quite simple



dial operated d. c. receiver.

Audio Oscillator

Professional set builders will recognize in the diagram No. 12 the unit as an audio oscillator. For portability and convenience, a 199 tube, 4½ volts C battery for filament supply and a small 45 volt B battery are required. Connect the C plus to No. 2, B plus 45 to No. 6, C minus to No. 7 and B minus to No. 3. Connect 3 and 4 together with short metal link. Set FIL at 3. This control is also used as a switch to shut off the unit. When a 201-A tube is used, the connections remain the same but a 6 volt filament supply is necessary. In this event the full use of FIL may be used. A test will determine whether your design of receiver will require the use of grid leak and condenser. When they are not used, it is necessary to connect B and G with a long metal link. Set FIL in position depending on voltage the tubes use. Adjust tuning dial of unit to about 50 degrees on the scale. Turn on the receiver and rotate the dial until the signal transmitted by the oscillator is heard. If a squeal or whistle is heard in the speaker it will indicate whether the oscillator is functioning properly. The pitch of the signal may be varied by changing the value of the grid leak in use. If desired, the unit may

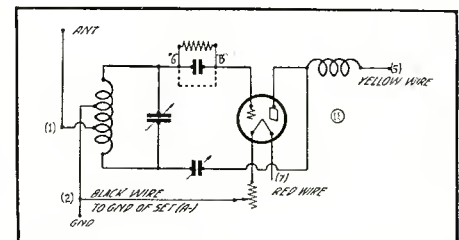
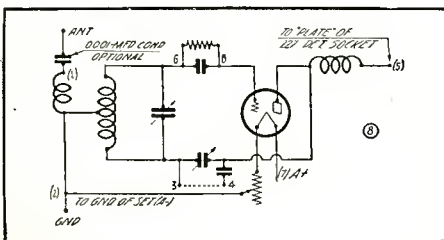

(Continued on page 114)

Automatic Tuning or Single Dial in Robertson-Davis Super Six

Automatic Model Fills Needs of Certain Class of Listeners;
Others Wish Regular Single Control

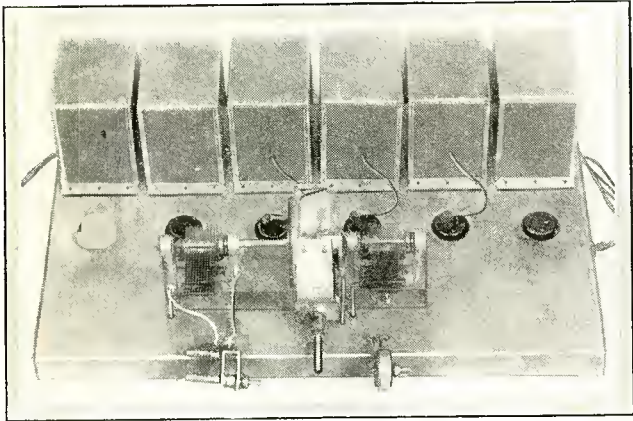

Fig. 1. This photograph shows the chassis of the Robertson-Davis Super Six with single control. The audio stages of the receiver are included in the power supply which is illustrated in Fig. 2

THE Robertson-Davis Super Six is a completely alternating current operated receiver of the superheterodyne type, employing three stages of a. c. shield grid intermediate amplification. It is a receiver of excellent power and selectivity, and no difficulty may be experienced in the assembly provided instructions are faithfully followed.

Two types of chassis are available, one without and one with the automatic tuning feature. The panel of each is the same as far as the main tuning controls are concerned, except that on the automatic chassis panel, the main tuning controls are all set to the left to provide room for mounting the automatic tuning unit. The one described in this article is the non-automatic. The chassis proper contains only the radio frequency portion of the receiver, while the audio frequency amplification and power supply is contained in an auxiliary unit.

Single Control Tuning

There is only one tuning control, this being the knob located at the center in Fig. 1, to which are attached both antenna and the oscillator condenser. The antenna condenser is on the left of the drum dial and the oscillator condenser on the right. The trimmer condenser is provided for aligning the antenna condenser with the oscillator condenser over the broadcast wave band. This knob is placed on the left-hand of the main tuning knob. Volume control is accomplished by means of variable resistance that controls the plate voltage of the intermediate amplifier. This knob is located on the right hand of the main tuning knob.

Builders should carefully inspect the bottoms of transformers before they are inserted in their respective sockets to be sure that none of the prongs that project through the base are in contact with the bottom of the can. Should any of the prongs be too close to the aluminum bottom, it will be apparent and should be remedied.

The receiver is designed for the use of Arcturus tubes. In looking at the photograph in Fig. 1, an Arcturus No. 28 tube should be placed in the left-hand or first socket. This is the oscillator tube. The next tube is the first detector and also uses

an Arcturus No. 28. The next three tubes are Arcturus No. 22 a. c. shield grid tubes and are placed in the third, fourth and fifth sockets. The last socket, or the right-hand one, is the second detector and in this is placed an Arcturus No. 28 tube.

At the left-hand side of the chassis near the rear, red and white leads are brought out. The red lead is to be connected to the ground and the white lead to be connected to the antenna. It is desirable to provide the best possible ground to be used with this chassis. With a poor ground, there is a possibility that a. c. hum will result. The length of antenna is a matter of locality. In congested broadcast districts a short antenna should be used, while in localities that are not so handicapped, it is possible to use an antenna as long as 100 ft., which, of course, will improve the range of the receiver. In case it is not convenient to erect an outdoor antenna, indoor aerials can be used with this receiver, with only a small volume diminution. It is also possible to receive some distant stations by merely utilizing ground contact. When this method is used, the ground should be connected to the antenna or white wire from this chassis. The red wire is then not connected.

Along the right-hand side of the chassis the power leads are brought out. These should be connected to the binding post on the power amplifier in the following order: The black wire of the twisted pair should be connected to minus A. The black with red tracer should be connected to plus A. This is important, because if these connections are not properly made, there will be a hum from the speaker. The green should be connected to the input. The yellow is minus C. The slate or natural color is plus 90 and the brown is plus 135. After these operations have been performed and the speaker has been connected to the power amplifier (care being taken to be certain that the two binding posts marked field are short circuited in case any speaker other than that requiring 100 volts d. c. for its field is used) the lead issuing from the power amplifier for connecting to the 110 volt supply should be plugged into that source.

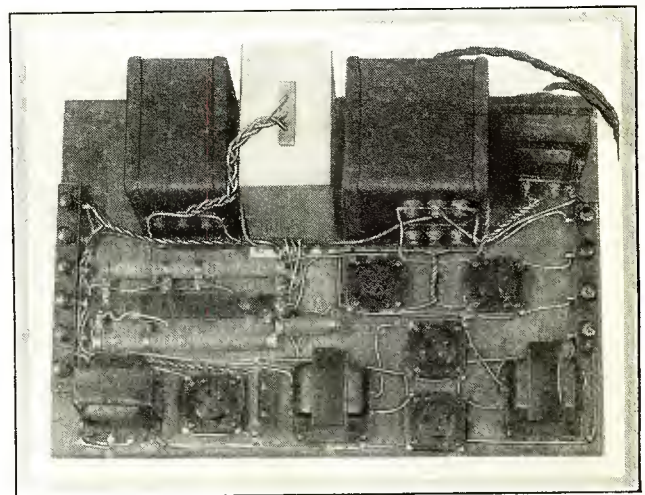

Fig. 2. This power supply is the one designed for operation in conjunction with the Robertson-Davis Super Six. It is shown schematically in Fig. 3

(This receiver tested and all illustrations made in our laboratory)

Hammarlund Two Tube Screen Grid Makes Adapter Combination

Easily Built Short Wave Unit May Be Used as Receiver Alone;
or Adapted to Set or Amplifier

AN interesting combination for short wave enthusiasts and others who wish broadcast entertainment on the higher frequencies has recently been marketed by the Hammarlund Mfg. Co. and a model built up in our laboratory for test purposes. It is known as the screen grid two tube adapter-receiver combination and is interesting not only from an economical standpoint, but from the simplicity of arrangement and the efficiency of operation.

Does Not Radiate

Some years ago when oscillating receivers became numerous there was quite a crusade against them. However, by the employment of the screen grid tube, when this tube is used as a blocking tube, and therefore prevents direct radiation into the antenna, many listeners may again return to the regenerative circuits secure in the feeling that they will not be disturbing the neighbors.

The completed receiver is shown in Fig. 1, while the front view of the panel is illustrated in Fig. 2. The schematic circuit may be found in Fig. 5, the graphic for the layman is shown in Fig. 3, while Fig. 4 is a baseboard layout of the arrangement of the receiver on the baseboard.

Increased R. F. Amplification

Employment of the screen grid tube increases the radio frequency amplification on short waves without complicating the operation in any manner. In fact, the operation of the set under such circumstances is actually improved because the regenerative detector is not directly coupled to the antenna and the antenna coupling does not have to be varied to prevent dead spots in tuning. As previously mentioned, of course, the presence of a screen grid tube as a blocking arrangement permits the regenerative fans to revamp their receivers into the up-to-date type suitable for picking up short wave broadcasts and code from almost limitless distances.

The construction of the short wave adapter has been simplified by providing a complete kit, including a drilled panel, all parts and hardware. In operation batteries are recommended because of the high sensitivity of the receiver with this type of plate supply. The converter may be used with sets having an A and B eliminator by disconnecting the detector supply lead plus 45 or plus 67 from the set and connecting a small 45 volt B battery in its place. The plus 45 volt terminal of this B battery should go to the set and the negative terminal should go to the B minus binding post of the receiver. The A battery leads should be permanently connected. The output arrangement of the two tube adapter is illustrated graphically in the diagram, Fig. 3, and schematically in Fig. 5. In the graphic, Fig. 3, it will be seen that there are two output binding posts across which

a B battery and a pair of head phones may be connected. If the unit is to be used as a two tube adapter in connection with an existing receiver, then one wire is carried to the plate prong of a tube socket and the other is carried to the plus filament prong of the socket. Thus, when this adapter is plugged into the detector socket, the output from the detector circuit in the adapter is fed into the first stage of audio in the receiver itself.

Amateur or Broadcast Work

For ordinary use, in amateur work, it is quite likely that merely a battery and a pair of head phones will suffice for a good telephone or telegraph signal. However, for broadcast entertainment on the short waves, one can generally assume that the listener will operate the small receiver in conjunction with an existing broadcast band receiver

so that the audio amplification inherent in the larger receiver will be employed for increasing the intensity of the short wave broadcast.

In addition to its use in the manner previously described, the unit may also be used as a separate receiver by adding one or two stages of audio frequency amplification to the output of the two tube adapter.

Tuning for the signal is accomplished by rotating the drum dial, which is the second knob from the left in the photograph in Fig. 2. The knob to the right of the drum dial knob is the on-off switch, while the regeneration control is the knob at the extreme right and governs the 100 mmf variable condenser used for the regenerative purposes.

The control at the extreme left is the variable resistance across the cap of the screen grid tube and the ground. By means of this, the signal input to the receiver may be altered from minimum to maximum.

A small midget condenser of 3 to 70 mmf is located on the baseboard between the plate circuit of the screen grid tube and the grid circuit of the detector. This acts as a coupling condenser between the two stages as well as the grid condenser. It may be shifted from minimum to maximum for best results, depending upon the wave band upon which operation is being attempted.

Broadcast telephone signals will be received on the receiver in a non-regenerative condition. This is similar to the manner in which signals are picked up on the higher broadcast wavelengths. However, for telegraph signals, it is necessary to advance the regeneration control until a faint "plop" is heard in the head phones and when a signal is tuned in, a squeal will be heard if the signal is of constant intensity. If it is broken up in the form of dots and dashes, it is safe to assume that it is either one of the commercial short wave transmitters or one of the amateurs. It is not possible by means of signal strength to determine the probable distance of the transmitter

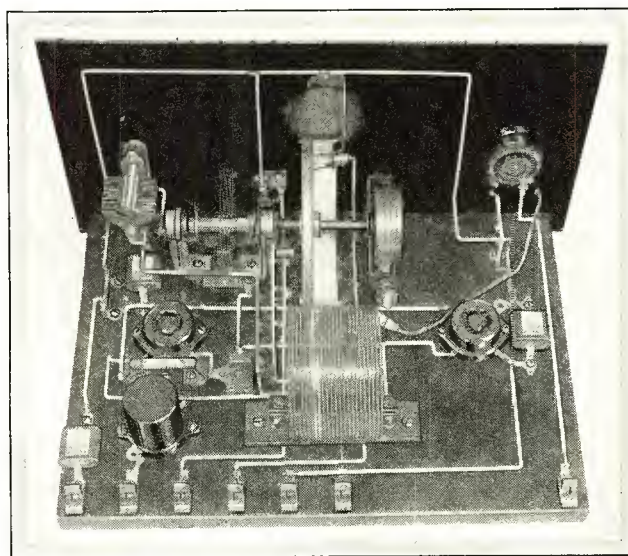

Fig. 1. This photograph shows the rear view of the completed Hammarlund two tube adapter employing a screen grid tube. The coil used is of the plug-in variety and is already located in place at the rear of the sub-panel

(This receiver tested and all illustrations made in our laboratory)

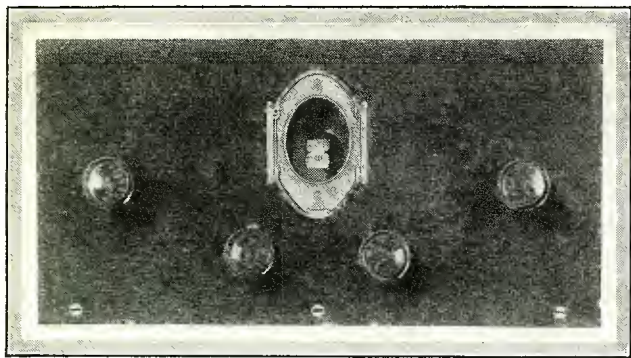

Fig. 2. This photograph shows the front view of the panel of the two tube short wave adapter. The control at the extreme left is the variable resistance between the cap of the screen grid and the ground. The next control is that of the drum knob, the next the on-off filament switch, the next control, the fourth knob at the extreme right turns the 100 mmf condenser used as a regeneration control

from the receiver, because on these short waves so frequently the foreign stations come in with almost as much volume as some of the domestic stations. By the same token, often the local telegraph stations will be comparatively weak, while a transmitter in San Francisco will deliver an exceptionally strong signal at the receiver.

Interesting Manual

Those who are interested in short wave work will doubtless welcome the publication of the recent Hammarlund short wave manual for 1929, which contains a good deal of very timely matter on short wave reception. In addition to a simple exposition of the factors involved in short wave reception, there is also material covering the screen grid tube, shielding of the r. f. stage, suggested volume controls, a list of short wave transmissions with the wavelength and call signals, a frequency-wave length conversion chart, together with a wealth of other material covering the subject of short waves. In the rear of the pamphlet are a number of charts showing the approximate calibration curve of the Hammarlund 20 and 40 meter coils and another set of charts for the 80 and 120 meter bands.

Official Parts List

Parts required for the construction of the Hammarlund two tube screen grid adapter receiver combination are shown in the list below:

- 1 Hammarlund ML-7 .00014 mfd Midline condenser

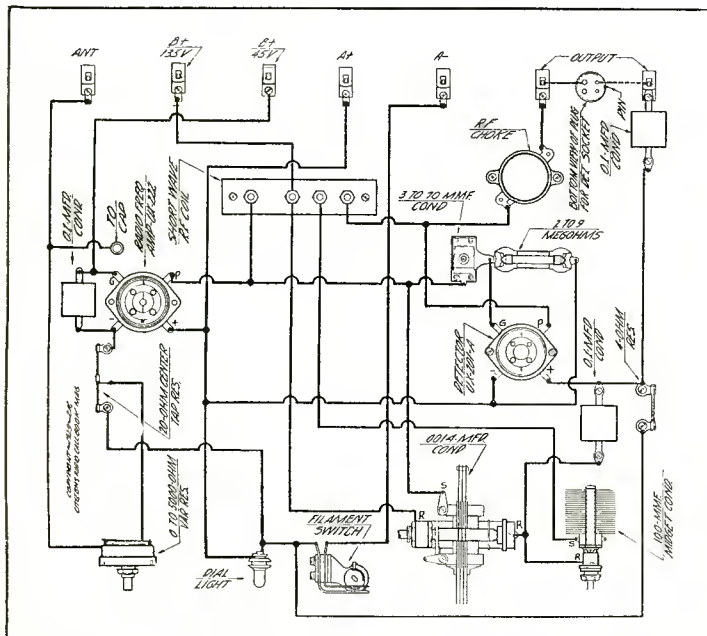

Fig. 3. A graphic illustration of the manner in which the various parts are wired together is shown in the above illustration

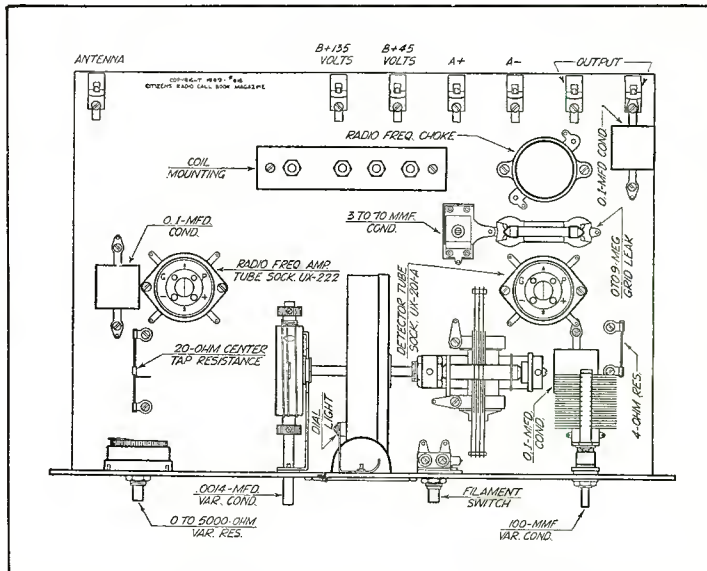

Fig. 4. This drawing represents the baseboard layout of the two tube short wave adapter, the panel for which is already punched and properly drilled

- 1 Hammarlund SWC-3 coil set
- 1 Hammarlund SDW knob, control drum dial
- 3 Hammarlund SDWK walnut knobs
- 1 Hammarlund EC-70 equalizer
- 1 Hammarlund RFC-250 radio frequency choke
- 1 Hammarlund MC-23 midget condenser
- 1 Hammarlund SWAP adapter plug and cable
- 3 Sprague type F .1 mfd condensers
- 1 Yaxley No. 10 midget battery switch
- 1 Yaxley No. 820 C, 20 ohm mid-tapped resistor
- 1 Yaxley No. 804 4 ohm resistor
- 2 Eby No. 12 sockets
- 1 Durham metallized resistor, 2-9 megohms
- 1 Electrad type P Tonatrol
- 1 Micarta 7x14-inch panel
- 1 Baseboard 9x13x3/4-inch
- 1 Pkg. containing hardware necessary to complete receiver
- 1 Pkg. Kester radio solder
- 1 Ceco or Sonatron 222 tube
- 1 Ceco or Sonatron 201-A tube

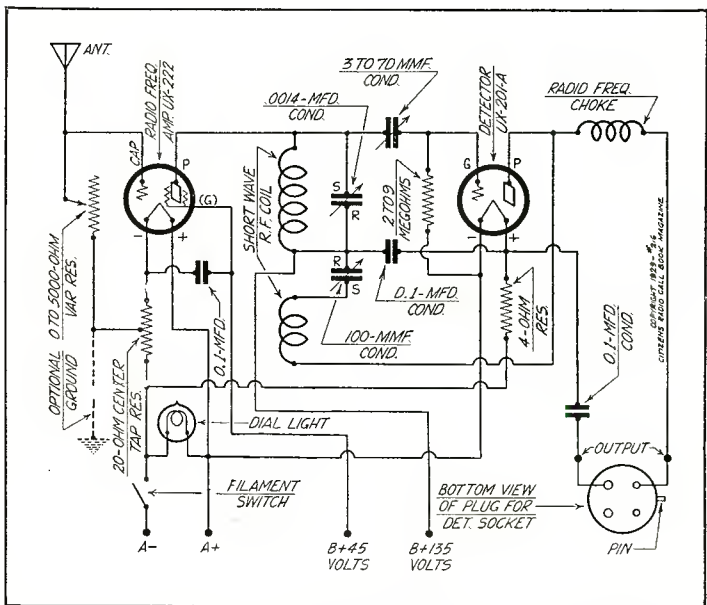

Fig. 5. The schematic circuit of the completed receiver is shown in the above illustration. It may be followed by those accustomed to working from a schematic, while the graphic should be used by the novice

Modulated Oscillator Handy Device to Have About the Workshop

Two Tube Filaments Energized From 2½ Volt Alternating Current; Unit Has Many Uses

GLANCING around in a professional set builder's workshop, a visitor could easily find any number of small parts or units from which handy devices might be designed, provided the professional set builder merely gave the matter a thought. For example: in the case of a modulated oscillator, nearly every professional set builder has use for one and furthermore is more than likely to have around the place the constituent parts for such a device.

Everyone Needs One

Even if one does not happen to have the necessary parts for such a modulator, nevertheless the utility of this device is such that there is hardly a professional set builder who can afford to be without one. This is especially true because it only takes about an hour or so to build one of the units up and furthermore the cost is very small.

Recently the technical department of our magazine put together and tested out such a modulated oscillator with a view to offering it to professional set builders. It was designed somewhat along the lines laid out in the December 15, 1928, issue of the Silver-Marshall Radiobuilder, with minor changes to take care of recent requests on the part of our readers.

Particularly the unit has three possible uses which will occur to professional set builders. The first is it may be used as a variable radio frequency oscillator to cover the broadcast band; it may also be used as a fixed frequency audio frequency oscillator running at about 300 cycles, or it may also be employed as a modulated radio frequency oscillator. One of the chief advantages of such a unit when attempting to determine the general nature of any trouble in a receiver lies in the fact that the test is made under actual operating conditions.

The unit is shown photographically in Fig. 1, where the two shielding cans have been removed to show the apparatus below. In Fig. 2 is shown the schematic circuit involved in the modulator, while Fig. 3 is a graphic diagram for those who are not accustomed to working from a simple schematic.

The filaments of the two 227 tubes, one used as an oscillator and the other as a modulator, are energized from a 2½ volt a. c. secondary of some suitable transformer. The plate supply for the circuit is either from a B eliminator or from batteries, as may be desired by the operator. In the schematic drawing shown in Fig. 2, it will be seen that the 227 tube at the left is the oscillator, with its tuned grid circuit and a fixed regenerative coupling. The tube at the right is the modulator and is connected in somewhat after the usual Heising modulation method.

To use the unit as a straight radio frequency oscillator, the filament

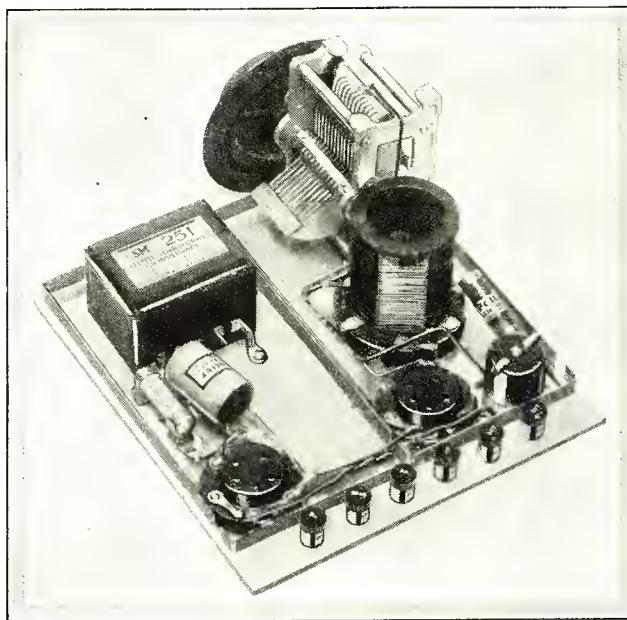

Fig. 1. This photograph shows the completed modulated oscillator, the two aluminum shielding covers being removed to show the material below

circuit is energized from a 2½ volt a. c. winding and 45 volts of B battery supplied to the terminals B plus and B minus. With a sensitive receiver, there will be sufficient coupling to the oscillator if it is placed within a few feet of the receiver. If the receiver gain is low, or the shielding is exceptionally good, more coupling may be provided by grounding one lead to the coupling coil and attaching a few feet of wire to the other coupling coil clip. To calibrate the oscillator, tune in some reliable broadcast station on the receiver and vary the oscillator condenser, with the AF tube removed, until the beat frequency is very low. Using the dial setting of the oscillator and the frequency or wavelength of the station, one calibration point may be plotted on cross section or co-ordinate paper. Eight or ten such points properly spaced will permit a graph to be drawn. The condenser used gives very nearly straight line wavelength curve. This particular coil and condenser gave

wavelengths of 300, 400 and 500 meters at dial settings of approximately 30, 60 and 90 respectively. The unit should be calibrated with the shield in place and it should not be removed when the calibration chart is to be used as the frequency is changed several per cent. If close coupling to some circuit is desired, a coil of 8 or 10 turns, 2½ or 3 in. in diameter should be connected to clips 5 and 6, this coil being coupled to the external circuit.

Once the unit has been calibrated, the reverse procedure may be

(Continued on page 120)

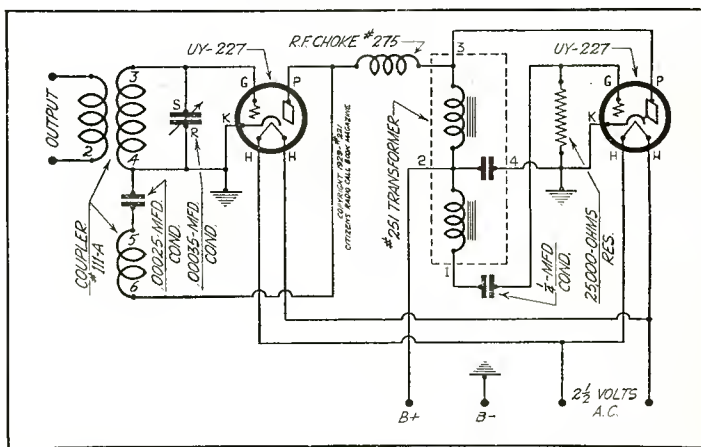

Fig. 2. The schematic circuit of the modulated oscillator is shown above, this diagram sufficing for wiring purposes for those who are accustomed to such work

(This unit built, tested and all illustrations made in our laboratory)

The Hammarlund-Roberts "HI-Q" 29 Model Is Operated from A. C. Line

Master Receiver Uses Tuning Method Giving Greater Radio Frequency Amplification Without Distortion

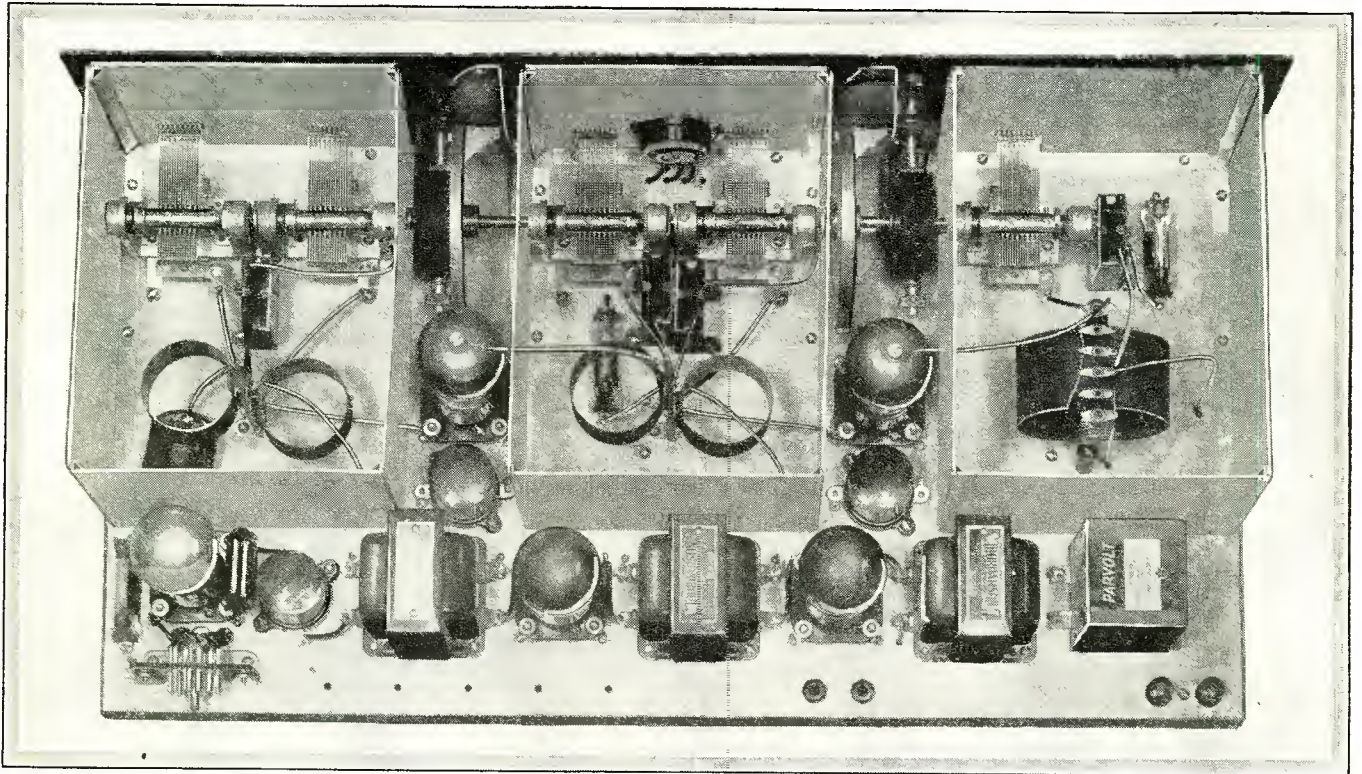

Fig. 1. This photograph shows clearly all the apparatus used in the construction of the Hammarlund-Roberts "HI-Q" 29 a. c. model. The three tops for the shield have been removed so as to give an idea of the parts used inside the cans

WITH the public turning in large numbers to the alternating current operated receivers, we are presenting in the accompanying article a description of the Hammarlund-Roberts HI-Q 29 Master A. C. model, which has been designed for the professional set builder to use in his campaign for custom built radio receivers.

Photographically the receiver is shown in Fig. 1, the three tops of the cans being removed to give an idea of the parts contained therein. Another photograph is shown in Fig. 2, where the receiver is illustrated in a cabinet. Fig. 6 gives a photographic view of the power supply built for the operation of the receiver. For the layman the graphic diagram shown in Fig. 3 will suffice as a means of wiring. The electrical details of the power supply are shown in the schematic in Fig. 4, while Fig. 5 is a baseboard layout of the receiver. Fig. 7 is a graphic diagram for the novice to wire up the power supply, while the schematic circuit in Fig. 8 gives all electrical details involved in the receiver.

Radio frequency amplification in the Hammarlund-Roberts

HI-Q 29 is achieved through careful design and by the use of shield grid tubes. Screen grid tubes represent the predominant advance in radio tube design in the past ten years. These tubes effect the phenomenal economy of tubes and circuit, increasing the electrical efficiency of the receiver and making practicable amplification heretofore obtainable only in many stage laboratory amplifiers. In properly designed circuits such as the one under discussion, the use of the screen grid tubes will bring in almost any station above the noise level. The Master HI-Q 29 when built according to specifications is a genuine coast to coast instrument.

This receiver employs a band pass filter, which effects absolute flat top square cut-off tuning with ten kilocycle selectivity. This means that with the receiver there can be no cross talk, and only one station can be received at a time, even in the larger metropolitan cities when many high powered broadcast stations broadcast at the same time.

The receiver has been simplified to the last degree, not only in operation but in construction. Every unnecessary factor has been



Fig. 2. The completed receiver is here shown in an attractive cabinet

(This receiver tested and all illustrations made in our laboratory)

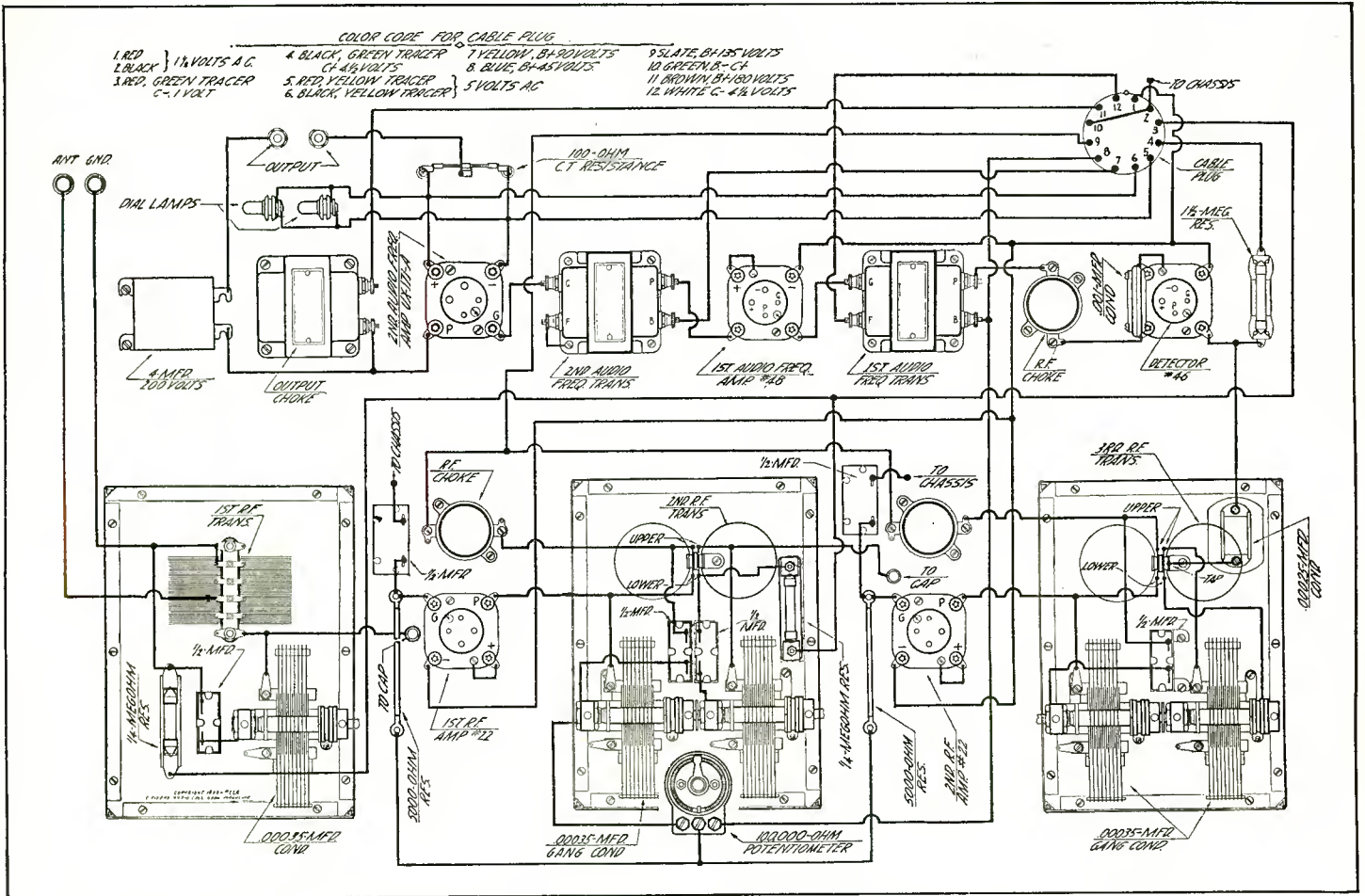

Fig. 3. The layman may readily wire up the receiver by following the connections shown in this graphic diagram

eliminated, just as every needful factor has been incorporated. Through a simplified control there is only one operation to perform, merely turn the dials and receive practically any station desired.

Method of Coupling

The performance of the receiver can best be understood by a consideration of the principles involved in the design. The inter-stage radio frequency transformers are quite unique in that they consist of two exactly similar coils. One constitutes the primary of the transformer and is connected to the plate circuit of the preceding tube, while the other coil acts as a secondary and is connected to the grid of the following tube. Each coil is tuned to resonance with the desired signal by means of a .00035 mfd variable condenser. Due to the rather unusual arrangement, the mutual inductance for coupling between the primary and sec-

ondary is much smaller than used in ordinary circuits. However, this does not mean that the energy transferred from primary to secondary is insufficient. In the case of the coupling coil used in the receiver under discussion, the maximum secondary voltage is obtained with the coupling coefficient on the order of 1 per cent. Physical arrangement of the coils as shown in the photograph of the completed receiver, Fig. 1, was chosen because it seemed the simplest way to secure this loose coupling, while still keeping the coils close to each other, thus conserving space.

Due to the inherent characteristics of loosely coupled tuned circuits, each of these doubly tuned radio frequency transformers really constitute the band pass filter. While one of these double tuned radio frequency transformers provides an unusual degree

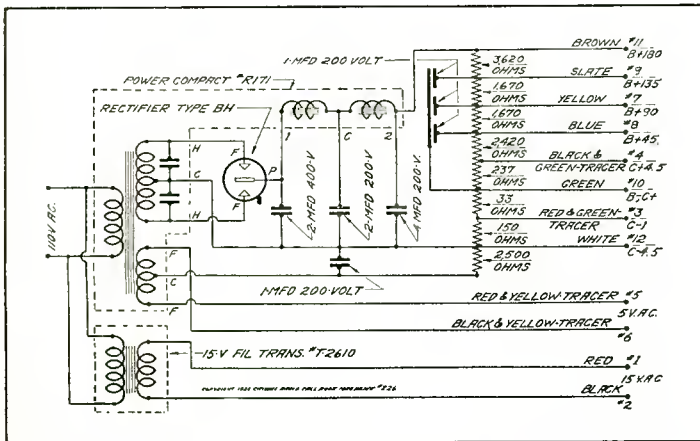

Fig. 4. The schematic circuit in the power supply is shown in the above illustration

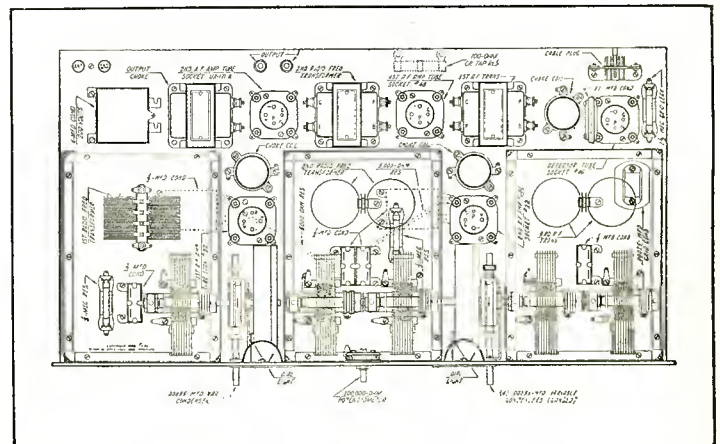

Fig. 5. This drawing represents a baseboard layout of the receiver described in this article. On account of the chassis being pierced, assembly and location of parts is quite simple and one cannot go wrong

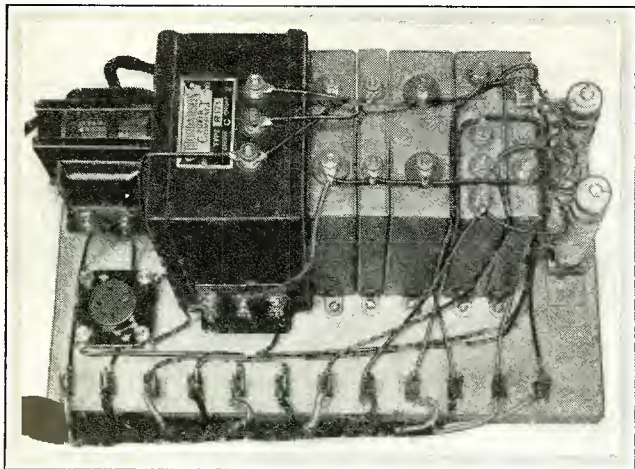

Fig. 6. This photograph shows the completed power supply used as a source of A, B and C current for the receiver

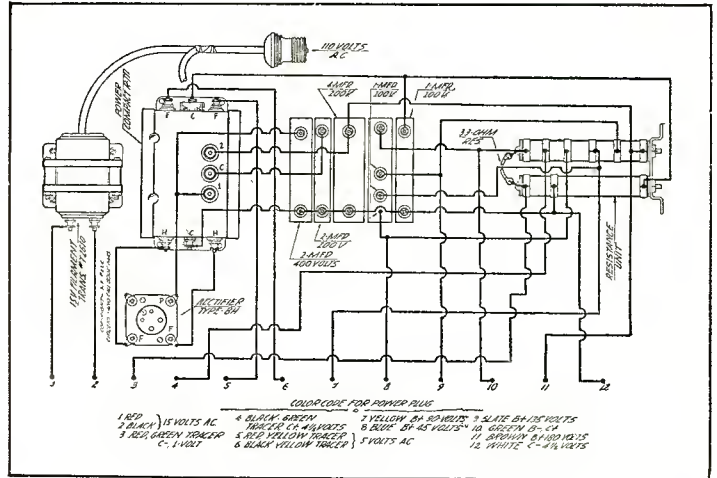

Fig. 7. This diagram is a graphic one of the power supply and the builder may follow it with facility in wiring up that part of the job

of selectivity, the use of two such stages in cascade results in a vast improvement.

Four Tuned Circuits

These two double tuned radio frequency transformers used in the Hammarlund-Roberts Hi-Q 29 necessitate the use of small variable condensers, one to tune each of the four coils. Since all four of the tuned circuits are identical, these four variable condensers are rotated by a common shaft actuated by a new model drum dial having a smooth positive drive without back lash. The tuned input circuit to the grid of the first shield grid tube, often referred to as the antenna coupler, is of the conventional type having a tapped primary, making it adaptable to several different lengths. The variable condenser tuning this antenna coupler is on a separate shaft and has a separate drum dial, thus enabling this circuit to be tuned to exact resonance of the received signal regardless of the type of antenna used.

The volume control is a little out of the ordinary and is made possible only by the characteristics of the shield grid tubes. It consists of a 100,000 ohm potentiometer across the 45 volt d.c. supply. The movable arm of this potentiometer provides the variable voltage which is impressed on the shield grids of the two r.f. amplifier tubes. The amplification obtainable from these tubes varies within wide limits as the voltage on the shield grid is varied, being at a maximum at about 45 volts and dropping rapidly as the shield grid potential is reduced. This provides a

smooth control of volume within wide limits without affecting quality or tuning in the slightest degree.

Ample Bypass Capacities

While the shield grid tubes have an extremely low value of capacity between plate and grid, thus almost entirely obviating the tendency of feed back to the tubes themselves, causing self-oscillation, this advantage is nullified if feed back occurs in other parts of the receiver. Taking this into consideration, every effort has been made to isolate all circuits in which coupling might result in instability. The negative bias which controls the grids of the r.f. tubes is secured by the drop across 1/4 megohm resistors in the grid return of each screen grid tube. Since the screen grids of both these tubes are biased by the 100,000 ohm potentiometer, a 5000 ohm isolating resistor is inserted in the leads to each of the shield grids, which is in turn bypassed by means of a separate 1/2 mfd bypass condenser. The plate circuits of these tubes are likewise isolated by individual filters consisting of separate radio frequency choke coils and bypass condensers. In addition to the above mentioned precautions, the entire r.f. end of the receiver is neatly shielded. Each stage is entirely closed in a snug fitting box which is securely fastened to the metal chassis. Shield grid tubes are so located that leads to the control grids are as short as possible and the farthest away from

(Continued on page 122)

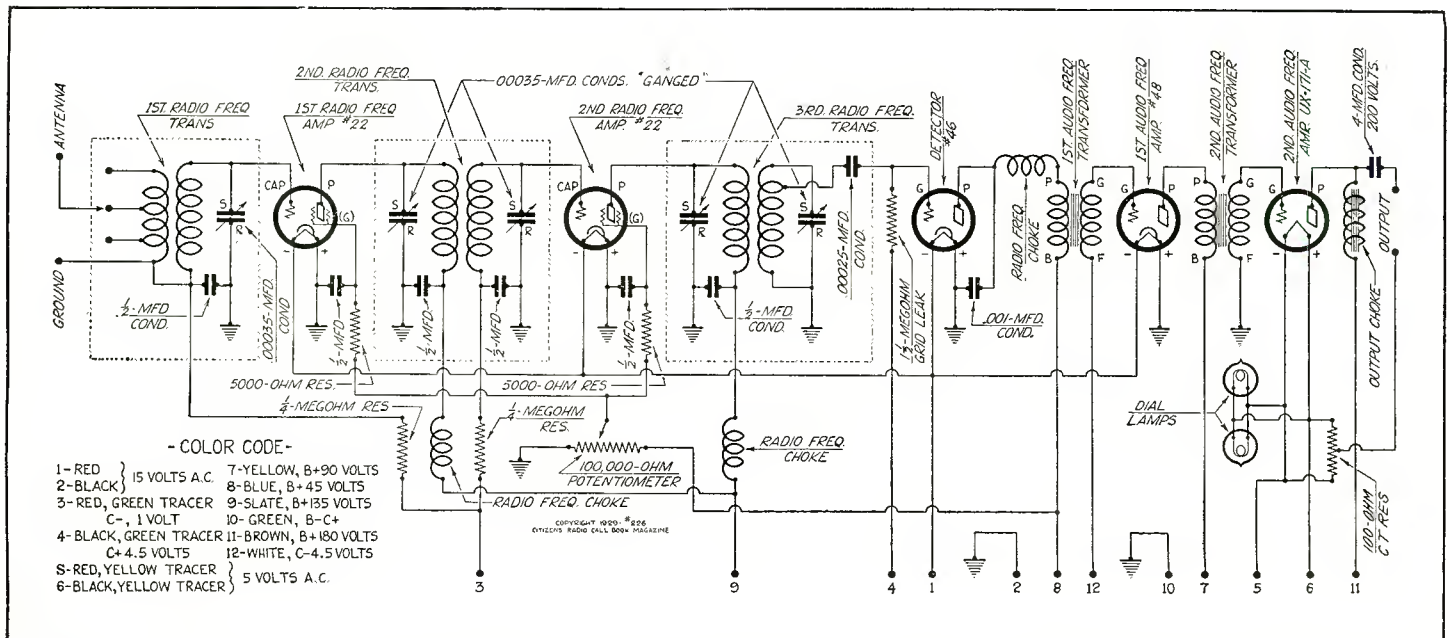

Fig. 8. The electrical constants of the receiver described in this article are shown in the schematic diagram printed above

AMPOWER AMPLIFICATION

(As It Relates to Commercial Installations in Theaters, Hotels, Apartments, Recreation Centers and Other Locations)

Wiring of Homes for Radio Is Source of Profit for Service Men

Speaker Lines May Be Run to Any Number of Rooms Desired With Set in a Central Location

IT is only natural that when radio had passed through the novelty and hobby stages and has become a necessity without which very few listeners would care to live, that set owners should seek a means of piping their entertainment to more than one room in the house. In the beginning it was generally sufficient for the radio receiver and speaker to be placed in the living room, since most of the family spent their time in that particular room. However, in some of the larger homes it soon became necessary for additional speakers to be installed in different parts of the house. For example, during the morning hour, the housewife would like a speaker in the kitchen. In the afternoon perhaps a speaker might be operated in one of the bedrooms, and in the evening the set would naturally be used mostly in the living room, although during the meal time it might be desired to have the speaker in the dining room.

No More Unsightly Wires

In the past in order to accomplish this desire, it required the running of a maze of unsightly wires under rugs, over doorways and branching out to various parts of the house. However, with the advent of the radio convenience outlets, such as those manufactured by the Yaxley Mfg. Co., it has become possible to run all of this wiring in lead conduit inside of the walls of the house and bring out the necessary outlets at the wall at whatever level is desired. It is in the planning for these features and in the carrying out of the installation that many professional set builders will find an opportunity for profit.

While it is admittedly best to project such installations at the time that the architect has the plans so that ample provision can be made for space in which these lead covered cables are to be carried, nevertheless even in completed homes it is possible by exercising a little ingenuity to run the proper cables from room to room and bring out the outlet at the wall as desired.

Such wire should not be run in standard conduit or Bx. On the contrary, the line should be of No. 19 twisted pair, lead covered, with the sheathing to be grounded. This method of wiring is recommended

on account of its elimination of capacity effect between the wires, which would not be the case were the wires to be simply placed inside of a conduit or enclosed in Bx. The other forms of wiring are perfectly satisfactory for 110 volt a. c., but in this case we are not dealing with alternating current but are dealing with audio frequency currents, in which the presence of capacity creates quite a disturbing factor.

An examination of the schematic diagram in Fig. 4 will give the professional set builder or service man an idea as to the method of making such an installation, either before the house is completely built or after it is finished. A Yaxley No. 136 outlet plate is employed near the radio receiver which is located in, preferably, the living room. This 136 outlet plate consists of an antenna and ground, whose two terminals are carried to the antenna and ground terminals of the receiver. From the detector output of the radio receiver, two wires lead into a Yaxley No. 60 double pole double throw switch, which enables the operator to change over from radio to phonograph at will. On one side of the switch combination are the connections for the phonograph pick-up and on the other side of the switch are the radio connections. The output of either the radio or the phonograph is placed on the input of the PAM-16 amplifier made by Samson. The wires leading from the detector output into the switch and from the switch into terminals Nos. 1 and 2 of the PAM-16 amplifier should be copper braid shielded leads. Here again it is also vital that capacity effect be guarded against.

The output of the PAM-16 amplifier is then carried through No. 19 twisted pair, lead covered, with the covering grounded into the six No. 134 Yaxley outlet plate located in as many rooms. These outlet plates are supplied with an impedance coil, so that when the speaker plug is removed from the jack, an impedance equal to that of the speaker is substituted in the circuit and allows the circuit to remain perfectly balanced.



Fig. 1. Homes of this type lend themselves readily to the placement of radio outlets in each of the rooms with the receiver in a central location. The work may be done either while the house is in the course of construction, or else after the building has been completed

Be sure to express your comments on this new department by means of the questionnaire on page 117 of this issue.

Your opinions as to the value of the material appearing herein will be greatly appreciated.

—THE EDITOR.

Dynamics and Magnetics

On account of the expense, it is hardly to be expected that all six of the speakers utilized in the house shown in the diagram in Fig. 4 would be of the dynamic type. However, it would be in keeping to have the master speaker, such as the one located in the living room together with the radio receiver, to be of the dynamic type, alternating current operated from a convenient plug.

Then the remaining five rooms could have the conventional magnetic type speakers for these reproducers, there being no necessity of any energization other than merely the audio signal fed into their magnetic windings.

Balancing Impedances

Probably the most important problem to be solved in working out a design such as the one shown in Fig. 4 is the balancing of the impedances of the speaker to match the impedance of the PAM-16 amplifier. As will be noted, the speakers in the living room, kitchen and dining room are in series with each other and then in parallel to the two bedroom speakers and the sun parlor speaker, which are also in series parallel.

Assuming that each speaker has an impedance of 2000 ohms, the living room, kitchen and dining room speakers together would give a total impedance of 6000 ohms, while the two bedrooms and sun parlor speakers would give a total of 6000 ohms. Then when these two sets of 6000 ohm impedances are placed in parallel, it would bring down the impedance to about 3000 ohms, which is satisfactory

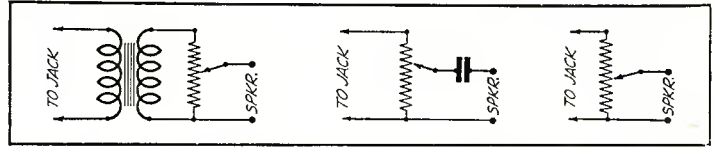

Fig. 2. In the above sketch are three methods of volume control which might be used on speakers in rooms remote from the receiver itself and where it is not possible to be running up-stairs and down-stairs to turn up and down the volume

for that of the Samson PAM-16 output. The output of the Samson PAM line of amplifiers is 2000 ohms at 100 cycles. For that reason it is well for the builder to ascertain the impedance of the speakers at 100 cycles, since that is the basis on which the PAM amplifiers are measured. From the foregoing, it will be seen that with the impedance of the PAM-16 at 2000 ohms feeding into a line having 3000 ohms, we have a satisfactory condition. However, it is not desirable to allow the impedance of the speaker circuit to drop below that of the amplifier circuit. While 3000 ohms would be satisfactory impedance for the speaker circuit, 1500 ohms would not be satisfactory. It is very important to bear in mind that the impedance of the speaker circuit should at no time fall below that of the impedance value of the power amplifier.

Wattage Output Rating

In considering the selection of a power amplifier for use in conjunction with work of this nature, it would be well for the professional set builder or service man to inspect the wattage output rating of the manufacturers as the basis of selection rather than the number and type of tubes which are employed. The reason for this suggestion may be readily seen from the following: Suppose a man

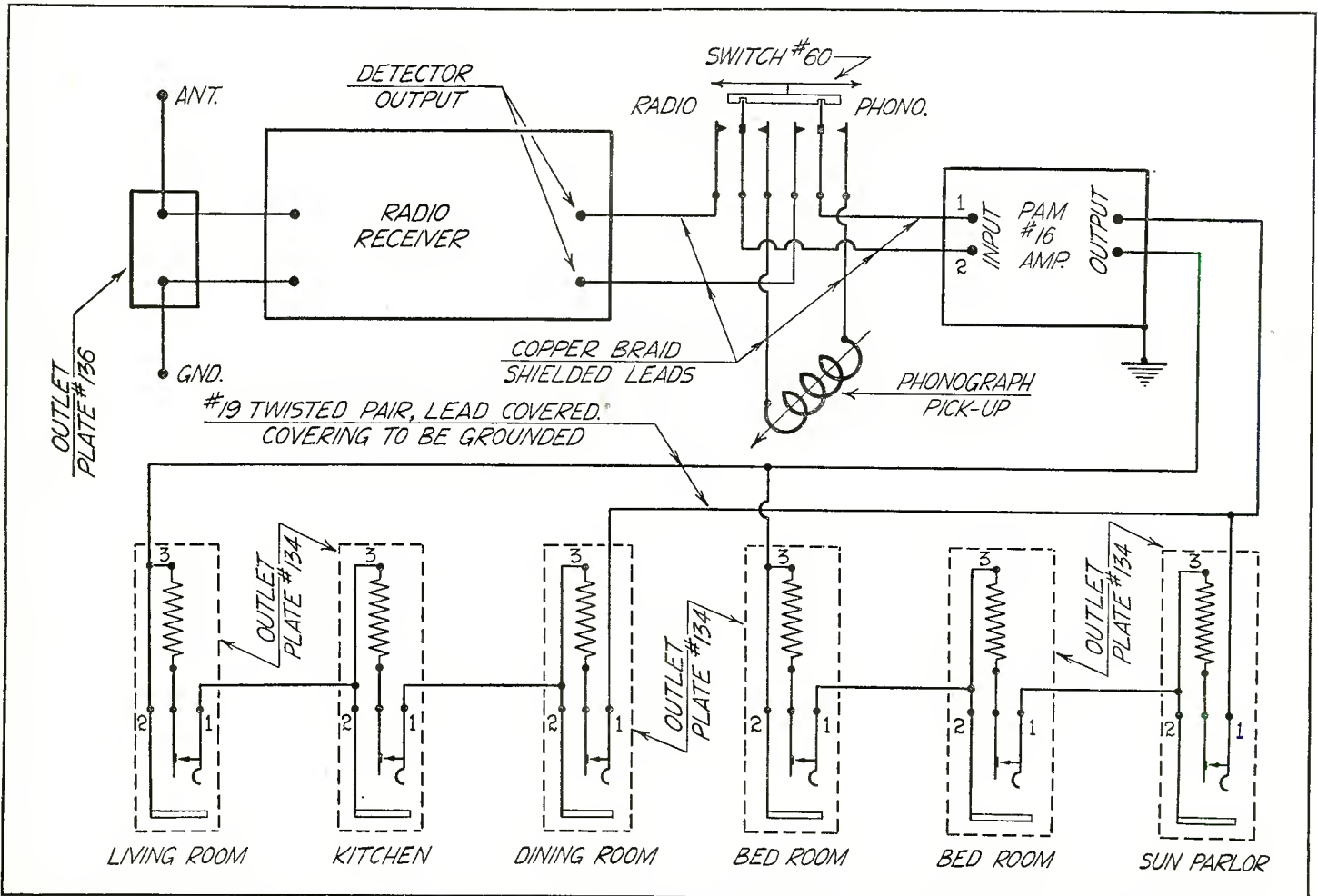

Fig. 4. This schematic diagram shows in part the method of connecting up six rooms on the output of a PAM-16 amplifier by means of the Yaxley 134 outlet plate. Details of the diagram are explained in the text of the accompanying article

goes into a store and says he wants an amplifier to use with a single 250 tube. He knows nothing of what the plate and grid voltages which are applied to this single 250 tube in the amplifier and if he does not know this, he does not know what is undistorted power output. Assume for a moment that the amplifier he is purchasing has only 250 volts on the plate of the tube and 45 volts on the grid. The wattage output of that amplifier would only be 900 milliwatts. On the other hand, if the voltage on the plate of the 250 were 450 volts and the grid voltage 84, the milliwatt output would be 4650, or over five times that of the first illustration, and yet the 250 tube is the governing factor in why he purchased the amplifier.

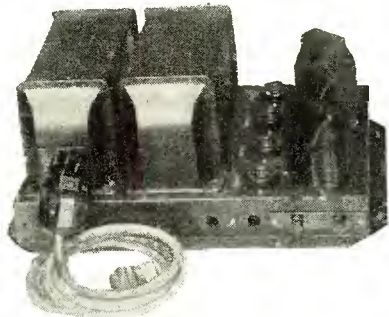

Fig. 3. Power amplifiers for use in connection with radio outlets in homes and apartments are generally of the type shown above where a Samson PAM-16 is illustrated

In a great many cases, people believe that a single 250 tube has more undistorted power output than two 210's in push-pull. Let us take, for a moment, an illustration of this kind. Assuming that you have an amplifier with a single 250 tube in its last stage and the plate voltage on the 250 tube is 400 volts and the grid voltage 70 volts. The undistorted power output in milliwatts of this amplifier would be 3250. Assume you have another amplifier using two 210's in push-pull with 400 volts on their plate and the grid bias at 31½ volts. The undistorted power output of this combination in milliwatts would be 3975, or more than that of a single 250 tube. Another illustration is this. Assume that we place 450 volts on the plate of a 250 watt tube in an amplifier and 84 volts on the grid. The resulting power output in milliwatts would be 4650. It is entirely possible that by taking two 210's in push-pull and increasing their plate voltage to 500 or 525, you have an undistorted wattage output of nearly 7 watts or 7000 milliwatts. It is, therefore, easy to see why one should take the undistorted wattage rating of an amplifier by the manufacturers as the guiding mark in purchasing an amplifier rather than the tubes that are used. Quality from either type of tubes would be the same if the rest of the amplifier is properly designed, and for the particular tubes used.

Volume Control Methods

It will be noted in the diagram in Fig. 2 that three optional methods of volume control for use on the speakers located in the rooms other than the living room are given. It is only natural to expect that if the master speaker in the living room is operating from the radio set, that the volume in the other rooms from the five magnetic speakers is not likely to be at the level desired by all individuals. For example, these in the living room might wish considerable volume, whereas an individual in one of the bedrooms might wish to cut down this volume because it was too loud. If no provision were made for cutting down the volume, then it would mean that the speakers would not be used or else an argument might ensue between members of the family as to the proper volume to be allowed. While it is not desirable to insert variable resistances in the circuit, on account of the possibility of unbalancing the impedance of the line, nevertheless if no other way out is afforded, the three methods shown in Fig. 2 may be tried out and the most satisfactory one employed. This at least will give the listener in one of the other rooms an opportunity of cutting down the volume without the necessity of having to go downstairs or to go into the other room in order to cut down the master control.

Helpful Information

Helpful information on this subject may be secured, as far as outlets are concerned, from the Yaxley Mfg. Co., 9 South Clinton Street, Chicago, and as far as amplifiers are concerned from the Samson Electric Co., at Canton, Mass. Professional set builders who have work of this kind in prospect would do well to communicate with these two companies and secure all of the available data possible.

Profit Making Possibilities

It has been our intention in establishing the Power Amplification section to bring before professional set builders, service men and others possibilities of profiting by the installation of radio house wiring or use of public address systems as a means of entertainment.

Opportunities for this work are not restricted to the metropolitan sections, although in the larger centers it is quite logical there should be a wider diversification of effort than in the smaller towns. Where in big cities there are hotels, apartment houses, dance halls and other meeting places in which public address systems may be installed, nevertheless in the smaller towns there are the movie houses, where a good electric phonograph-radio combination will put to shame the efforts of the local piano player. Then again there are lodge rooms, into which entertainment can be piped. Aside from this, there is the possibility of equipping a small town dance hall with a good phonograph and radio combination, whereby the dance music output of some of the better known and powerful broadcasting stations may be utilized and the gaps filled in by the playing of first class phonograph music from nationally known dance orchestras.

Many of the problems encountered in such installations will be reviewed in these columns and an effort will be made to clearly set forth the remedies. Manufacturers of public address systems maintain expensive and extensive technical staffs, upon whom the user of such equipment can call in the event that installation problems are too complex or difficult for him. Some of the manufacturers even go to far as to dig up new uses for amplifier systems. In this respect it would be advisable for the professional set builder or service man to communicate with the Samson Electric Co. at Canton, Mass., and Silver-Marshall, Inc., 836 W. Jackson Blvd., Chicago, Ill., requesting literature on amplifiers for public entertainment.

Want Your Interest

Having started the department in this issue, its continuation will rest to a large extent upon the co-operation and the interest shown by the professional set builders and others. If there is widespread interest in this section, we would like to secure some indication of it, and towards this end we would like to remind our readers they express their opinions in the questionnaire which we are printing on page 117 of this issue.

Even after an installation has been made, whether in the city or elsewhere, such a job will always remain as a possible source of profit for the replacement of tubes. As far as the audio end of the installation is concerned, there is nothing involved which can wear out or it at all likely to break down. Therefore, the only place where replacements may be anticipated is in the matter of tubes, and even here the service man has an opportunity for profit.

Another place in the smaller towns where a service man might sell the phonograph-radio combination is in the local restaurant. Then, again, the local music store, where records are for sale, might also be a prospect for a good phonograph amplifier, permitting the use of a hand microphone for making announcements prior to and subsequent to the playing of records for customers.

Seeking Best Dynamic

With so many demands for public entertainment, it is becoming necessary for the manufacturers of dynamic speakers to take this type of apparatus into consideration. While it is true that a number of small dynamics can be linked together quite satisfactorily for good operation, nevertheless when it is desired to cover an auditorium with a single speaker the problem becomes more difficult. Our laboratory is now working with dynamic manufacturers in the search for a large dynamic to handle effectively the greater volume required for auditorium work. We are also experimenting with various models and during the summer expect to work out definite recommendations along this line.

Consequently it will be worth while for the professional set builders and others to watch for our forthcoming issue, in which we will doubtless have something interesting to say concerning the larger dynamics for auditorium work.

(Continued on page 129)

Modified Rack-and-Panel Amplifier Now Available at Low Cost

Silver-Marshall 690 Amplifier Designed in Response to Demand of Movie Projectionists and Others

APPEARING originally in the January issue as a bread board amplifier, a modified rack-and-panel amplifier is now available, having been designed by Silver-Marshall in response to the demand of motion picture projectionists, experimenters and service men for amplifying apparatus capable of giving sound reproduction of finer tone quality than is experienced with the usual talking movie and similar public address installations. In the new sound amplifier are introduced certain features not previously found even in the best talking movie and broadcast station amplifiers.

The S-M type 690 amplifier has been designed to provide sufficient power when fed by a microphone, a radio set or one or more phonograph record pick-ups to operate two to twelve dynamics or the loud speaker unit at sufficient capacity to adequately fill or cover a theater or auditorium seating 3,000 to 5,000 people. Out of doors it will provide speech and music clearly to crowds of 10,000 to 30,000 people, according to the estimate of the designer.

The 690 type public address amplifier incorporates features recently developed in the S-M laboratories, such as dual push-pull amplification, full a. c. amplifier operation, a frequency characteristic bringing out low tones at their full volume, fading

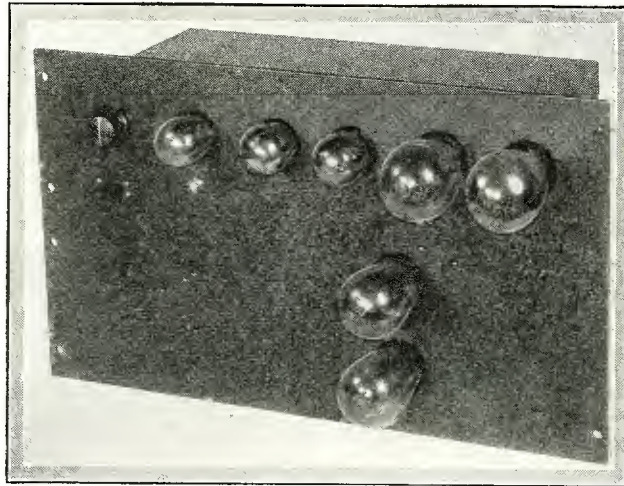

Fig. 1. This photograph shows the original model of the 669 rack-and-panel amplifier. In the production jobs there is a metal plaque at the left upper corner, showing the calibration for volume and instruction data for the position of tubes used in the amplifier

volume control, three-way selector switch, and a rack-and-panel type of full aluminum construction. General assembly features are exactly the same as those found in the highest grade apparatus built where performance alone is the object.

The overall amplification is sufficient to develop the full undistorted power output of the UX-250's in the output stage, 15 to 16 watts or more, when operated from radio, record or microphone input. The power amplifier with its self-contained power supply is mounted on a solid aluminum panel 14x21 inches wide with all tubes projecting from sockets from below the panel face. One 227 tube is used in the first stage, two 226 tubes in push-pull in the second stage, and two 250 power tubes in the push-pull output stage. The power supply employs two 281 rectifier tubes in a full wave rectifier system delivering 450 volts to the plate and 80 volts to the grids of the 250 tubes, thus insuring an undistorted power output of 15 to 16 watts, and appropriate A, B and C voltages to the other tubes. A special 225M input transformer allows microphone, radio or record output to be fed to the 227 tubes. A 257 transformer coupled to the two 226 tubes and they in turn are coupled to the 250 tubes through a 227 trans-

(Continued on page 126)

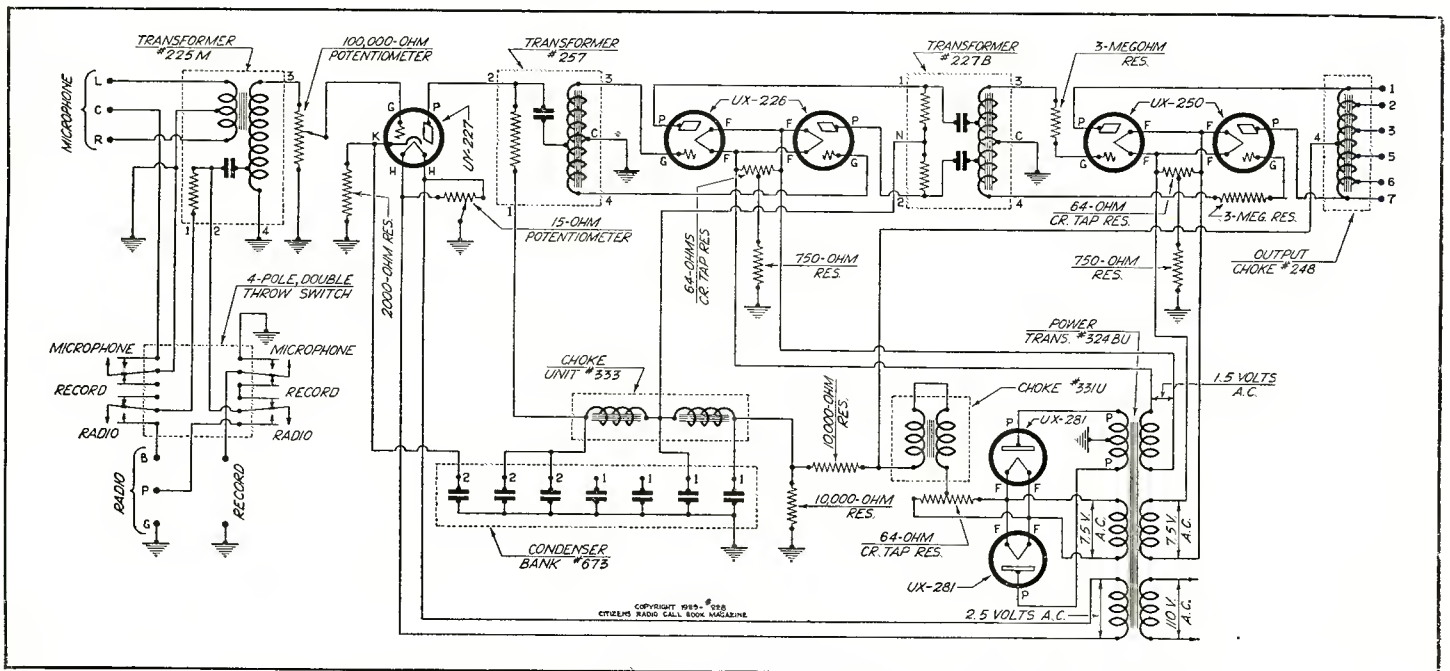

Fig. 2. The schematic circuit involved in the rack-and-panel amplifier is shown above



With the PROFESSIONAL SET BUILDER

Laboratory Experimentation on the Design and Construction of B Eliminators

THE past year has seen a tremendous advance in the design of "A" and "B" eliminators operating directly from the home light-socket. Properly designed and constructed, the results obtainable from these units are superior to battery operation. However, there are many important factors involved in the design of such an eliminator-power-supply, and it is the purpose of this article to present the results of many months laboratory experimentation in an effort to produce a "B" eliminator that would give known voltages when used with various receivers, such as would be found in the regular run of laboratory or service work, as well as for the usual receiver operation. The results of this work are shown in the complete circuit as given in Fig. 1.

It is a well known fact that much trouble may be encountered through the use of a "B" power eliminator of inadequate design. Any general service man will agree that many difficulties of light-socket operation may be traced directly to poor design incorporated in many commercial and home-made "B" eliminators. An analysis of many such cases invariably led to one or more of the following causes:

(1) Poor regulation of the power transformer supplying the rectifier tubes. This is usually caused by scanty design found in some commercial articles of a competitive nature.

(2) Faulty filtration due to poor design of filter chokes and an insufficiency of filter condenser-capacity.

(3) Poor design of the voltage-divider network, the function of which is to provide the necessary bleeder-load on the rectifier supply and to supply plate-voltages for receiver operation. C-bias voltage is also included as a function of modern units.

(4) Cheap rectifier tubes, or tubes that have been used beyond their useful life.

(5) Inadequate resistances, usually caused by the incorporation of resistances in power units with too small a factor of safety, thereby resulting in resistance burnouts, noisy operation and voltage variation at the usual supply taps.

(6) Excessive voltage variation. This trouble is extremely common in many power units and a constant source of distortion and low operating efficiency in the receiver attached thereto. This is evidenced in many forms, such as "tagging," "motorboating," lack of stability and distortion of tonal output resulting in thin, raspy output especially noticeable on sustained or heavy volume.

The circuit as given in Fig. 1 was designed to eliminate all of these faults and at the same time supply smooth humless voltages of known values to the usual run of receivers. Careful tests and measurements have proven that this circuit is capable of producing results superior to batteries and possessing a rare degree of voltage stability. The voltage at the 180 and 90 volt taps will remain constant, and may be relied upon to remain so under

the most severe usage. An analysis of the component parts of Fig. 1 will now be given:

The power transformer is of rugged design capable of supplying from 85 to 100 milliamperes continuous duty without heating, or will furnish double this current for reasonable periods. It contains two 300 volt secondaries, one 105-120 volt, 60 cycle a.c. primary and one 7½ volt, 4 ampere filament winding. With the 280 type rectifier tube a 1¼ ohm filament resistance is connected in series with the winding to give 5 volts at 2 amperes.

The filter chokes are a combination of a brute-force and selective system known as the SM No. 331 unichoke. Its specifications are: Inductance 30 henries at 110 milliamperes load. Rated at 125 milliamperes continuous duty; d.c. resistance 395 ohms completely shielded electrostatically.

The filter condensers are Electrad types: Class 450 and 650, the class referring to the working voltage of each type. The direct-current working-voltage of the 4 mfd should be 600 for safety and insurance against breakdown. The capacities of each are shown in Fig. 1.

The design of the entire eliminator is centered around the Electrad Truvolt divider, a voltage-divider of unusual efficiency and utility. The voltage-divider of any eliminator usually determines the applicability and efficiency of the entire unit, other component parts being of generous proportions. This unit as given in Fig. 1 is entirely self-contained and requires no calculation. Any constructor can incorporate this entire unit in an eliminator and obtain positive operation of all voltages automatically, and the voltages at the 180 and 90 volt terminals will remain constant under all practical loads.

Heretofore, no unit has been generally available for the constructor and the production of the Truvolt divider is timely and noteworthy. All guess-work and tedious experimentation is entirely unnecessary whenever this unit is attached to a good rectifier filter-output. It is completely wired and laboratory calibrated with excellent accuracy. The complete unit requires only two wires for installation and ready use, these connections being indicated in the drawing.

All voltage adjustments are accomplished by five knobs; knob B-2 providing any voltage between 120 and 160; knob B-3, 60 and 120 volts; No. 4, any potential between 20 and 60 volts; knobs C₆ and C₇ provide adjustment of "C" bias voltages which are, of course, negative in value. Knob C₇ will range from 20 to 40 volts negative, and knob C₆ from 1 to 20 volts negative.

The resistors used are of rugged design, wound with high quality nickel alloy wire, and possessing a temperature co-efficient of practically zero. These resistances will not rust or oxidize, and are perfectly noiseless in operation and permanent in adjustment values. All resistances except the auxiliary bleeder are rated at 50 watts. As comparatively little current flows through the re-

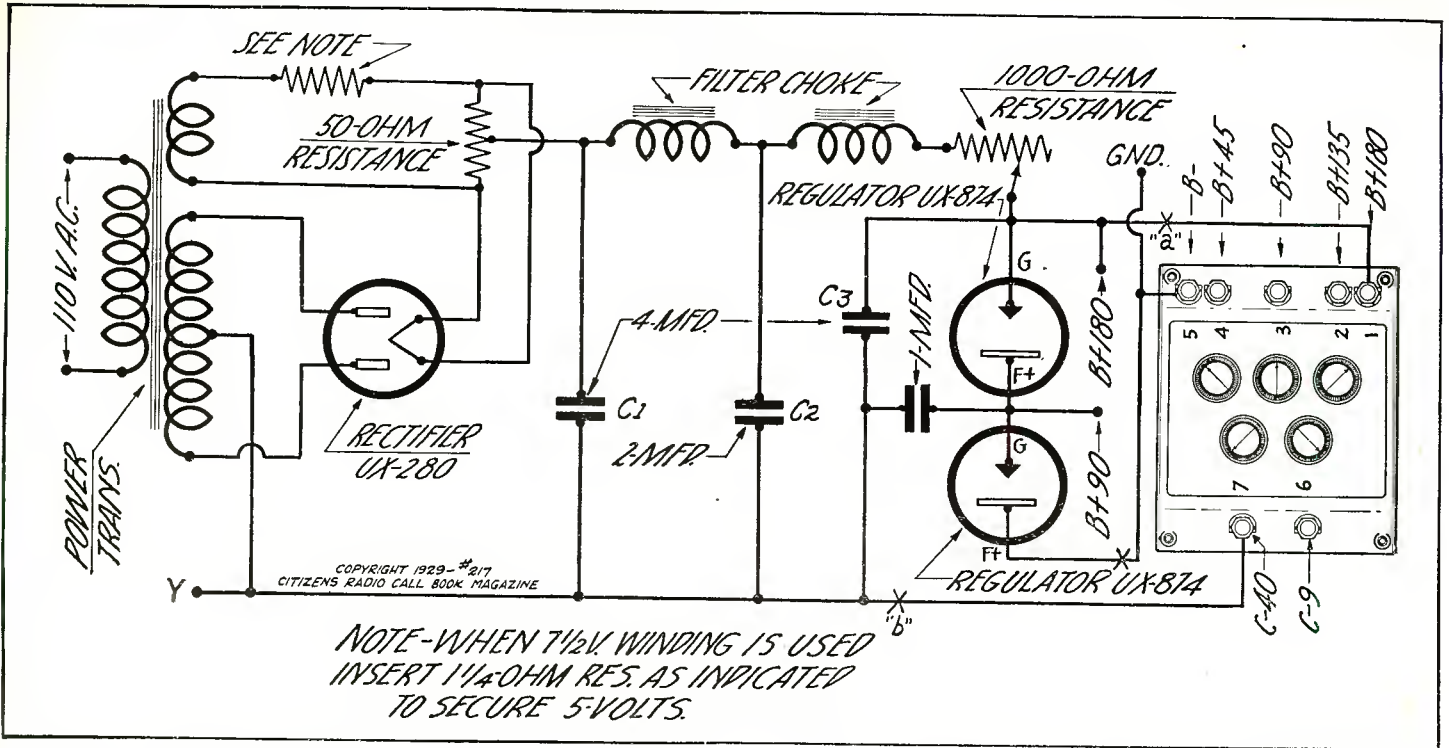

Fig. 1. Transformer, rectifier and glow tube portion of this circuit is shown schematically, while the resistance network is shown graphically

sistance unit from B+45 and B-, the rating of this section is lower, but substantially rugged. As the total resistance of the entire divider is 11,000, the bleeder current, which is the current flowing in shunt across all voltage taps, under condition of open load across voltage taps, would be found from the formula:

$$I = \frac{V}{R}$$

when, I = bleeder current in milliamperes.

$$I = \frac{180}{11000}$$

I = 16 milliamperes. V = voltage applied at terminals of divider.
R = resistance of voltage divider.

This would apply only when no current was drawn from the voltage taps. Whenever current is drawn from the voltage taps, such as would be the case when a receiver was being supplied with plate-voltage, the bleeder current varies inversely to the current flowing from the voltage-divider to the receiver. The setting of the five knobs may be easily determined for the correct operation of any receiver by a glance at the thoroughly complete manual of information provided with every Truvolt divider. The data is not only mathematically accurate and comprehensive, but extremely practical and simple for the regular radio fan to understand and apply.

Two voltage regulators, UX-874's, are used to maintain stability of voltage at the terminals 1 to 4, B+90 and B+180 volts, respectively. By using two of these "glow" tubes in series, as indicated, constant voltage under all conditions of operation will be guaranteed.

The main resistor has a resistance of 0-1000 ohms and should be a Truvolt D-10, rated at 75 watts. This unit should be very rugged, as it must carry the entire output of the rectifier filter. The adjustment necessary to secure proper starting and operating voltage for the two "glow" tubes can easily be made by sliding the contact until the current flow through the series glow tube circuit is about 45 milliamperes. This may be measured by inserting a 0-50 or 0-100 scale milliammeter in the series circuit as indicated at "x" in the schematic diagram.

Under operating conditions a voltage of 180 volts will exist across the two tubes in series. At this voltage the component Electrad voltage-divider will draw about 16 milliamperes when no set is attached; that is, under open load across the terminals 1, 2, 3 and 4. As the UX-847 glow tubes should draw about 50

milliamperes under open load, the sum of 16 milliamperes through the Electrad divider and 45 milliamperes as measured by the milliammeter when inserted at "x" will be about right for best operation. This will provide substantial operating current for the 874's and guarantee uniform regulation under the severest loads when taken from taps 1, 2, 3 and 4.

This is of the utmost importance, especially in amplifiers designed to amplify frequencies between 30 and 100 cycles as is now common procedure wherever good tonal output is desired. However, as a caution, emphasis should be placed upon the necessity of all by-pass condensers as shown in the circuit diagram. Every voltage tap should be thoroughly by-passed with at least a 1 microfarad condenser capable of standing the particular voltage at which it will be constantly worked plus an additional factor of safety; otherwise condenser blowouts may result.

Reference to the schematic diagram will emphasize the simplicity of the entire circuit made possible by the use of the Electrad Truvolt divider, obtainable completely wired and housed in a beautiful bakelite case. The equivalent internal circuit is also included as a matter of interest. See Fig. 2. It should be noted that all condensers are connected externally; that is, they are not encased in the divider unit itself. Even if they were, it would be necessary to by-pass every "B" battery lead again at the receiver proper to avoid feed-back and coupling through the long plate-supply wires.

When terminals 6 and 7 of the divider are used, as in the schematic, the ground should be on terminal 5. If 6 and 7 are not used, ground should be at Y.

Milliammeter placed in series at x-"a" will read C bias current and B 45 current.

Milliammeter placed in series at x-"b" will read C bias current and all B current.

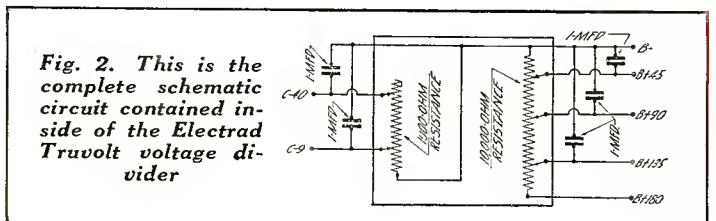
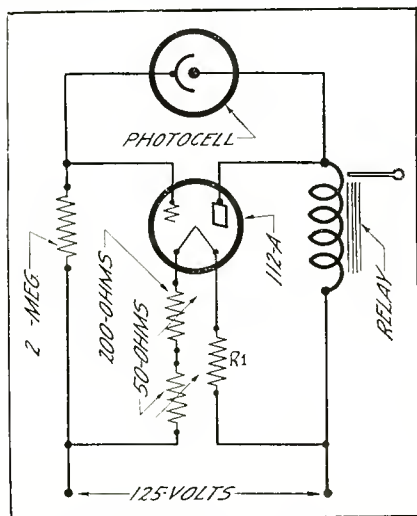

Fig. 2. This is the complete schematic circuit contained inside of the Electrad Truvolt voltage divider

Opening Garage Door with Light Beam

FOR those interested in experimenting with the photo-electric cell, the opening of the garage door with a beam of light from the usual flashlight, is something at once practical and thrilling. The details are given in the accompanying diagram. The photo-cell in this case is a Type 3 GS Raytheon FotoCell, having an ionization voltage of 152 volts. Several different tubes have been tried with this circuit, but the 112-A tube has proved most satisfactory. R-1 is a variable resistance of 200-ohm range, R-2 is a 50-ohm variable resistor, while the third resistance in the filament circuit is a 420-ohm fixed resistor. R-1 and R-2 control the C bias on the 112-A tube. The third resistor provides the necessary voltage drop across the filament of the 112-A tube.



When the Foto-Cell is in darkness, about .25 milliamperes flows in the plate circuit of the 112-A tube. When the flashlight is placed close to the cell, a current of about 6.25 milliamperes flows in the plate circuit.

The relay, which happens to be a Yaxley relay, has a resistance of 8300 ohms. It is easily operated by the flashlight at a distance of 10 feet from the FotoCell. The relay actuates at about 2.5 to 3 milliamperes, and will hold down at about 1 to 1.5 milliamperes. The garage door may be slid or swung by a suitable motor drive.

The entire arrangement shown has been designed to operate directly from a 125-volt d. c. line, although B batteries may be employed if preferred. Also, other variations may be worked out to suit conditions and desires.

Neat Dealer's Amplifier

THE photograph shown above represents the handiwork of a Chicago set builder, who recently constructed the Thordarson push-pull dealer's amplifier, appearing a recent issue of this magazine. As will be seen, the entire job has been shielded

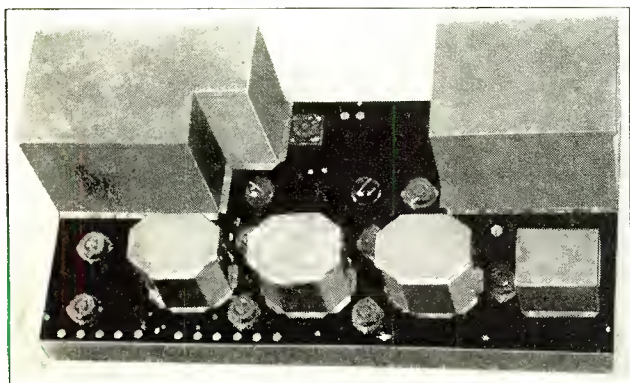

and in addition the copper cans have been highly burnished, so that it represents an extremely pleasing appearance. This is just one of the many samples we constantly see of craftsmanship on the part of professional set builders.

Thordarson Audio Manual

ALL radio enthusiasts are interested in power amplifiers, and the fact that Thordarson Electric Mfg. Co. has recently published a power amplifier manual should be of more than passing interest. The booklet is available from the Thordarson Electric Mfg. Co., Kingsbury and Huron Sts., Chicago, Illinois, at 25 cents a copy.

The Thordarson power amplifier manual is a simple, yet complete, treatise on the subject of audio amplification, including full information on the building, servicing and testing of power amplifiers and power supply devices in general. It also contains details and specific constructional data on twelve individual power units, with clear-cut pictorial layouts and diagrams of each.

In addition to fully covering the Thordarson line, there are a number of pages of material of considerable interest to the professional set builder and service man, since the data given therein applies to testing, servicing and repairing power supplies. In addition to that, there is a table of tube data, giving the constants of the better known general purpose and power tubes.

Interference Locator Loop

IN the January issue of our magazine there appeared an article on a Citizens Interference Locator, which has aroused considerable interest. In the above photograph we are showing the interference locator loop and two sticks by means of which it is hoisted into position for probing near a power line. As stated in

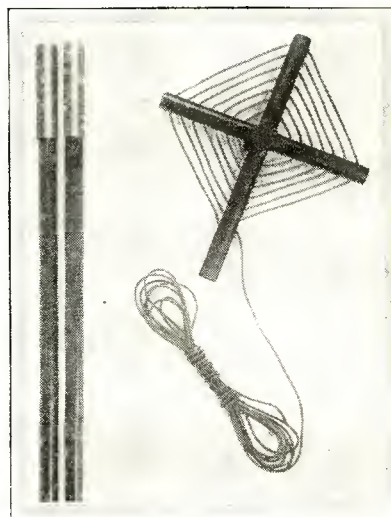

the January issue, the loop is made to order only by the Vee Products Co., 173 N. Michigan Ave., Chicago. The loop is approximately 8 inches in diameter, while the two poles are 5 feet long and are joined together by means of brass ferrules. The loop and the two poles sell for \$7.50 net.

Tobe Works on Interference

WE understand the Tobe-Deutschmann Co. have recently made an exhaustive study of interference problems, data on many of which are contained in a monthly bulletin which they publish, known as the "Filterette."

This bulletin will be sent without charge to any professional set builder or service man writing to Tobe-Deutschmann Co., Canton, Mass., and mentioning this publication.

Information of this nature is bound to be helpful to those who are constantly called upon to service receivers, only to find the cause of the difficulty is interference from some electrical machinery in the neighborhood. Extensive study of this subject will undoubtedly enable many service men and others to locate and correct troubles that might be bothering their customers.

Filter for Interference Reduction More Necessary Than Ever

Startling Increase in Use of A. C. Sets Brings Forth Need of Proper Filter to Kill Noises

STARTLING increases in the sale and operation of alternating current receivers this season has brought into the limelight more than ever the necessity for good filtering to eliminate electrical noises produced by machinery operated electrically. In the past when the majority of the receivers were operated from storage batteries for both filament and plate circuit, electrical interference, although present, was not so obvious because there was no connection to the electric light line.

Can Reduce Interference

However, with the present a. c. receivers, where both the filament and plate supplies are derived from the alternating current line, the public is beginning to notice a good deal of interference which they did not encounter before. Practically 99 per cent of this interference is caused by electrical devices of some nature, and in every case, with a possible few isolated ones, it is possible to reduce or eliminate this interference by the proper employment of filter condensers.

As a matter of fact in many instances where the radio set owner complains of interference he finds that apparatus on his own premises may be at fault. This is particularly true in the case of oil burners, where electrical means are utilized for keeping alive the flame. Then again the use of a heating pad in a home, especially where the thermostat in the heating pad is not of the proper type, will give rise to interference which is audible in a radio set.

Seek Legislative Remedy

So insistent has the demand become for a reduction of man-made or machine-made interference that many municipalities and even some states are considering the advisability of legislation, directed first toward the manufacturer to prevent the sale of any electrical apparatus which will give rise to interference, and second, against the individual possessing apparatus which gives off radio interference on wavelengths between 200 and 600 meters. We notice in this connection that Tobe-Deutschmann of Canton, Mass., is known as the father of a model ordinance directed against radio interference of the preventable type. Those interested in the elimination of interference by means of legislation may communicate with Deutschmann at Canton, Mass., and secure from his company copies of the model ordinance which it has been necessary to have passed in certain localities where interference was quite heavy and where the creators of such interference took no steps to abate it.

What Causes Interference

An idea of the widespread interference possible from the various electric machines may be gained when it is stated by interference experts that sign flashers, sparking motors, elevator circuit breakers, X rays, ultra-violet ray machines, automatic telephones, electric sign switchers, precipitating apparatus, automatic heating pads, toy trains, electric railroads, power leaks and ozonators create about three-fourths of the interference heard nowadays. In addition to that interference may be created by washing machines, vacuum cleaners, refrigerators of the motor type, hair dryers, pumps, oil burners, ventilators, electric fans, sewing machines, automatic clocks or any household implements employing small motors.

There are enough oil burner problems in the prevention of

interference to make it necessary for W. K. Fleming, chief engineer of the Tobe-Deutschmann Co., to issue a pamphlet on that subject alone. For those professional set builders and service men who have encountered interference of this type, it is suggested that they communicate with the Tobe-Deutschmann Co. and request literature on oil burner problems.

The multiplicity of sounds which are heard in a radio set is so great and so varied that it is difficult to determine what is causing the disturbance. In a great many cases a disturbance may be set up several thousand feet away and create as much interference as if it were next door.

It is plain to see that in order to locate and suppress these disturbances one must be able to determine what is causing the trouble and where it is located. This is not so difficult as it may seem, as the service man soon becomes familiar with peculiarities of sound set up by various pieces of apparatus.

What They Sound Like

About the easiest type of interference to detect is that caused by universal type motors used on appliances previously mentioned. This interference is usually heard as a high pitched whine or singing tone, either running steadily or varying in intensity. In other cases it is heard as a buzzing sound, which is rapidly varying in intensity as the motor starts and then remains constant in pitch. Disturbance set up by a generator or d. c. motor is very similar to that described in the preceding paragraph. However, it is considerably rougher in tone and steady in character, with a slight crackling sound mixed up with a steady buzzing. Disturbance set up by the ignition of oil burners is heard as a steady, rough buzzing with a wavering intensity and crackling sounds at frequent intervals. The disturbance set up by an electric refrigerator is heard as an intermittent crackle, sometimes in addition being steady, without any fluctuation. The disturbance set up by heating pads is heard as a rough, crackling noise occurring at intervals from one to five minutes. Sometimes the sound suggests code transmission.

In order to aid the service man as much as possible in the location and prevention of interference, the Tobe-Deutschmann Co. has found it necessary to publish a monthly bulletin known as the Filterette. We are advised by the Tobe-Deutschmann Co. that there is no subscription connected with the publication and any set builder or service man may secure a subscription by writing the company and mentioning the name of this publication.

Three Types of Filters

In looking over the first issue of the Filterette, which is Vol. 1, No. 1, we observe that three distinct types of filters are required to secure satisfactory elimination of radio interference. The type most generally used depends on filtering effect on capacity only, the second depends upon inductance only, while the third type depends upon a combination of inductance and capacity. It is of prime importance that the condensers used in capacitative filters be capable of continuous operation at the maximum operating potential of the filters. To secure satisfactory operation it is therefore necessary to use a condenser with an extremely high safety factor. The safety factor decided upon was five times the working voltage of the filter. The condensers used while under

(Continued on page 131)

Service Man May Test Rectifier Tubes With This Simple Outfit

Designed for Determining Emission of Each Cathode, It May Be Used for 280 or 281 Rectifiers

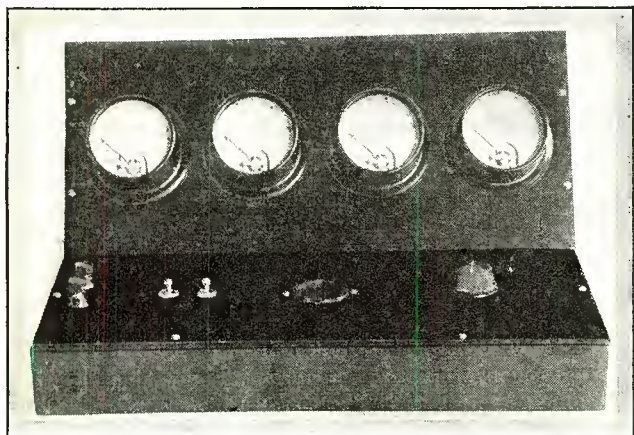

Fig. 1. This photograph shows the completed 280 tester recently made up in our laboratory. Whereas in this particular photograph there are four meters shown, in the schematic in Fig. 2 only three are illustrated because three will actually perform the work desired

THE rectifying tube tester as herewith illustrated was designed primarily for use in the production department of a tube factory, but may very readily be adapted for use in a store or service department, where there is a quantity of tubes tested. Although it does not test the tube for gas content or flash-over, it is a very simple and effective means of checking the tube for filament emission, which is the most important factor in a rectifying tube.

Designed for D. C.

This tester was designed for use on 110 volt d. c., as there are a great many factory districts and store districts where alternating current is not available. However, it may be readily adapted for alternating current. If alternating current should be used, a high voltage transformer is necessary and a filament transformer may be used in preference to the storage battery. In this case, the filament voltmeter and the 110 voltmeter will be replaced by an a. c. filament voltmeter and 110 volt a. c. voltmeter.

The average readings as taken on direct current type for a 280 tube will average about 100 or 110 milliamperes per anode. It is immediately apparent that the total output of 200 to 220 milliamperes is approximately a 100 per cent overload above the rating of the tube. This, however, is greatly desirable in the testing of the tube, inasmuch as weaknesses will develop that would not do so on underload or rating conditions.

Gas Content Cause

A condition of gas content in a rectifying tube will at times cause a hissing or bubbling noise in the receiving set, and as the 280 and 281 types of tubes are supposedly high vacuum tubes, the presence of gas content is not desirable. When a tube is new it oftentimes will not show gas content, but after being used some hours, the action of the high temperatures on the elements of the tube will cause a derangement of the molecules and release gas. This is an impossible condition to be able to find when a tube is new or nearly new. When the tube is tested, if there appears

around the filaments and plates a blue haze, it is a symptom of gas content. However, upon the instant of filament incandescence, there may appear a blue haze around the filament, which disappears almost immediately. This is not necessarily gas content, but merely an instantaneous ionization of the atmosphere immediately surrounding the filament, and will be dispersed very rapidly. In case that the filament has sagged to a position which is dangerously near the plate there will probably show a very decided increase in current for one anode, and if close enough will flash-over. In case of alternating current operation, this flash-over point will be at a much lower anode current than on direct current.

If one of the anode milliammeters reads lower than the other the filament for that anode is not as active as the other one. If this deviation is more than 10 milliamperes, the tube will not give satisfactory use. If both milliammeters are low, the same condition exists and the tube should not be used.

This tester consists of 4 meters, 150 volt d. c. voltmeter, a filament 0-8 voltmeter and two 150 milliammeters, a tube socket having extra strong springs, one switch for 110 volt a. c. line and one for the filament line. In the d. c. tester, the filaments are heated by a 6 volt storage battery and a 1 ohm 20 watt rheostat is used to adjust the filament voltage.

There is placed in each of the anode circuits a fixed resistance of 750 ohms. These should be matched to a 600 ohm value. If both are not of the same resistance value, the anode meter readings will not be alike when such a condition should exist. These resistors should be able to safely stand 150 milliamperes. The 281 type of tube under ordinary conditions should test in the neighborhood of 70 milliamperes, but, of course, as there is only one anode, there will be but one milliammeter giving a reading.

(Continued on page 126)

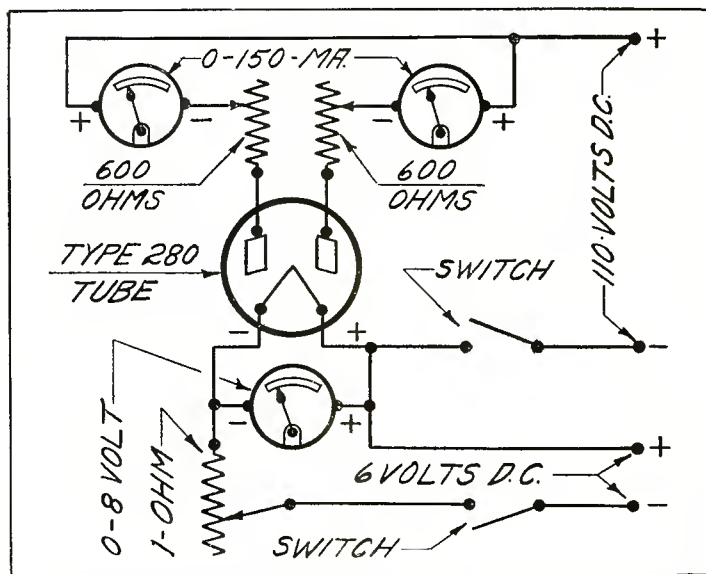

Fig. 2. Schematic circuit of the 280 rectifier tester is shown above. A 6 volt d. c. source is required for the filament of the 280, and 110 volts d. c. is required on the plates in order to determine emission

(This tester designed, tested and all illustrations made in our laboratory)

B Eliminator, A Battery Charger and Relay for 110 Volt D. C.

Combination Unit Employs Truvolt Divider for Resistances and Yaxley Relay for Change-Over

OPERATION of small radio sets from the 110 volt direct current line is not a difficult matter and arrangements may be made whereby in addition to supplying the B current, the 110 volt line may be used as a method of charging the A battery and keeping it up to its normal level. Many requests have recently come into the laboratory from residents of direct current districts who wish some simple combination which would perform the desired purpose and still not be much of a bother for maintenance.

Is Convenient Combination

With this in view, the combined A charger and B eliminator 110 volt d. c. has been designed in the laboratory and thoroughly tested out. Essentially the unit consists of an Electrad Truvolt divider for the resistance network, a Yaxley 440 relay as a method of changing over from operation of the receiver to charging the battery, a Samson 30 henry choke for eliminating commutation and other inherent electrical noises in the line, together with a couple of bypass condensers used in association with the 30 henry choke. The photograph of the completed unit is shown in Fig. 1, while Fig. 2 gives a schematic diagram of the manner in which the set should be wired. The graphic diagram is shown in Fig. 3 and may be followed for wiring purposes by those who are not accustomed to working from the schematic.

In view of the fact that it is imperative that connections be made properly, it is suggested that the graphic diagram, Fig. 3, be scrutinized very closely. This is particularly true with respect to the B power and A charger receptacles at the end of the Yaxley 440 automatic relay. In order for the unit to operate properly, it is vital that the connections be made exactly as indicated in the graphic diagram. For example in the case of the B power receptacle the lead from C-7, which is the negative side of the circuit, must go to the lower terminal of the B power receptacle, while to the upper terminal the wire or connection going into the 30 henry choke is connected. Then on the A charger receptacle, the positive or upper terminal goes to one side of the 110 volt lamp and then through it to No. 4 post on the right side of the automatic relay. The lower terminal of the A charger receptacle goes over to the set A minus and A battery and to No. 3 post of the automatic relay at the right. If this exact method of connection is not made, there is a possibility of short circuit and consequent burning out.

It would also be extremely wise for the user in connecting up the 110 volt d. c. input to the automatic relay to utilize a polarity plug so that by no chance will it be possible to plug in the outfit with the wrong polarity. Examination of the schematic in Fig. 2 will show

that the positive side of the line is the one that goes to the two positive connections in the receptacle.

With this arrangement, when the radio set is being operated, the portion of the circuit designated as the B power receptacle and relay is in operation and furnishes plate current for the receiver. When the filament switch of the radio receiver is turned to the off position, it trips the relay, which throws the A charger into operation through the incandescent lamp so that the battery may be on charge whenever the receiver is not in actual operation.

Variable Charging Rate

The size of the incandescent lamp used in the receptacle will determine the charging rate applied to the battery. For example: with a 200 watt light, 1.6 amperes per hour will be fed into the battery. With a 60 watt light, .5 amperes will be the charging rate, while with a 100 watt light 1.2 amperes will be the charging rate. If the receiver is only used for a small portion of the time, it is quite likely that the 60 watt lamp will be sufficient, since it will give a half ampere charging rate and will be in operation for more than three-quarters of the twenty-four hours.

While it is true that perhaps the greatest voltage available from the unit will be approximately 95 volts, this disadvantage in the operation of a set using 135 or 180 volts may be eliminated by the employment of a separate B battery between the maximum voltage of the eliminator and the plate of the power tube.

When inserting the added battery into the circuit, the negative terminal of the added battery should go to the positive terminal of the B supply, while the positive terminal of the added battery should go to the plate of the last tube. By means of the little knobs on the Truvolt

divider, it is possible to secure various voltages as desired by the operator. For example: voltages from 90 down to 22 may be secured from the different taps which are B2, B3, B4, B5, C6 and C7. In some cases it might be desired to use 22½ volts, whereas in others the operator might wish 45, while still other cases might demand 67½ volts.

It will be noted that this Yaxley relay is an automatic one and when the voltage of the storage battery has been brought to the required value by the charger, the EMF generated in the voltage coil will be sufficient to hold down its magnet, thus breaking the 110 volt charging circuit. It will, therefore, be seen that there is no possibility of an overcharge with this sort of arrangement, because when the voltage rises to the necessary value on the storage battery it will be automatically cut off by the relay. The

(Continued on page 128)

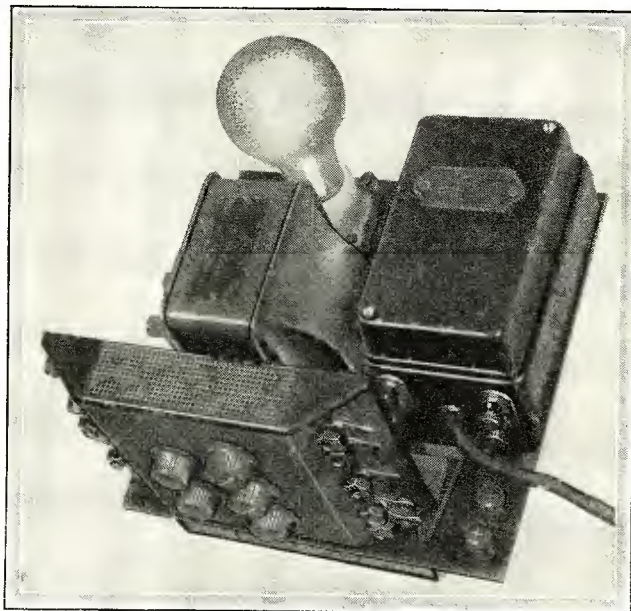

Fig. 1. In this photograph may be seen the automatic direct current B eliminator and combined A battery charger, involving a relay, a voltage divider, a choke and a lamp, by means of whose voltage the charging rate may be governed

(This unit designed, tested and all illustrations made in our laboratory)

Lamp Bank Serves as a Resistance in Simple A Battery Eliminator

Such Method May Prove Useful in 110 Volt D.C. Section;
Easy B Supply Also Explained

ON many occasions in the past, the Information Department of this magazine has been requested by readers to supply some sort of a diagram illustrating a method of using their 110 volt line, direct current, as a means of lighting the filaments in a radio set.

Easily Understood

While any such method of eliminating an A battery would be more or less wasteful of current, nevertheless the system outlined in Fig. 2 in the accompanying article is probably the simplest to construct and the easiest for the layman or beginner to understand. Reference to the schematic in Fig. 2 will show that the A eliminator unit consists of a bank of electric sockets, into which are placed a number of 50 watt lamps, depending upon the amount of current or amperage that it is desired to pass. For example: in the drawing provision has been made for eight lamp sockets into which as many 50 watt lamps may be placed. Under these conditions this lamp bank would operate a radio set consuming as high as three amperes of current. By suitable changing in the number of lamps used, this current consumption can be reduced to a point where with one 50 watt lamp only $\frac{1}{4}$ of an ampere of current is passed. Thus, any range of current value from $\frac{1}{4}$ of an ampere to three amperes may be governed by the number of 50 watt lamps inserted in the sockets of the A eliminator.

Close Voltage Regulation

Close inspection of the diagram will show the presence of a 100 ohm potentiometer located between the positive terminal of the 5 volt d. c. output and the negative terminal, but located in such a way that this potentiometer will permit a variation of output voltage. Perhaps a simpler description of the matter would be to state that the potentiometer, located as it is, serves as a means of securing fractional voltages at the output.

Precautions to Take

There are points of importance in the operation of this A eliminator, the first being that the set should not be turned on and off at the receiver itself. On the contrary, it should be turned on and off at the point marked as a switch in the diagram, Fig. 2. The set should not be turned on or off at the receiver, nor should

tubes be taken out of the set when the switch shown in the diagram herewith is closed, because if this were to happen, the voltage would rise on the receiver and it is possible that a tube might be burned out, and it is also possible that the 0-10 volt-meter across the output line might be damaged.

It is also important to note that the unit must be only operated with a fixed condenser in the lead from the set binding post to the ground. This is to prevent trouble in the event that the receiver is grounded at the negative and that the supply line happens to be grounded at the positive. If this condition existed, naturally trouble would arise.

It will be seen by examining Fig. 2 that a 100 ohm potentiometer is specified across the plus and minus 5 volt d. c. line. The reason why a potentiometer is used is that it has no open position, and, therefore, it will always remain in the circuit, which is imperative with this particular design. If a rheostat were to be used and by accident the knob turned until the pointer was in the open position, the withdrawal of this resistance from the circuit would increase the voltage across the voltmeter and consequently burn it out. By all means do not make the mistake of trying to substitute a rheostat for the 100 ohm potentiometer specified.

Simple B Eliminator

In addition to the method shown for the elimination of the A battery, the diagram shown in Fig. 1 is a simple method of making a B eliminator for 110 volt d. c. current. It consists essentially of one 30 henry choke, one 10,000 ohm fixed resistance with two clips on it and two 2 to 4 mfd bypass condensers with a rating of 100 volts or higher. The maximum voltage of the eliminator will be approximately 90 volts, while the two variable taps

(Continued on page 129)

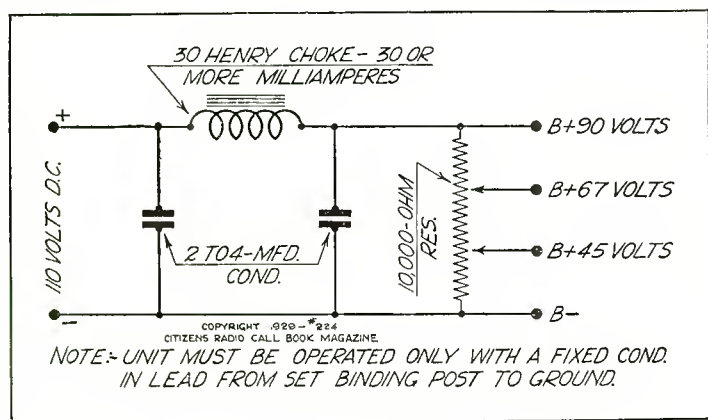

Fig. 1. A simple schematic circuit is shown above, where the B supply for the receiver may be constructed

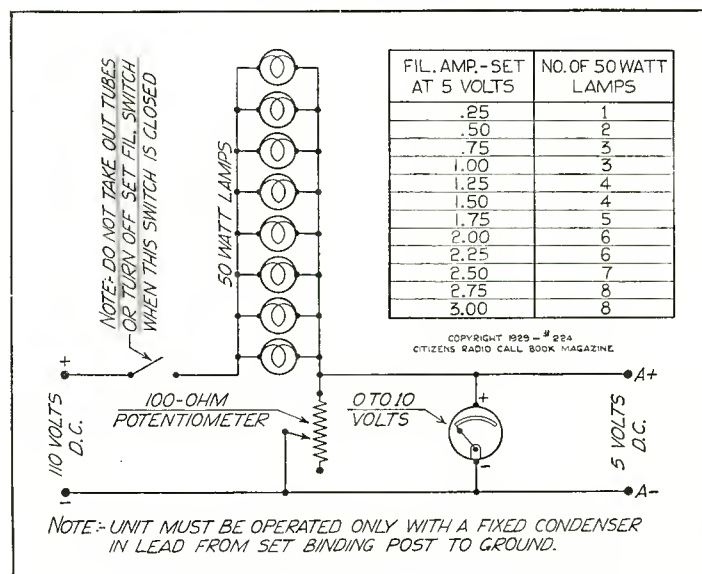

Fig. 2. Herein is shown a schematic circuit of the method of fixing up a bank of lamps as a means of eliminating an A battery on 110 volt d. c. supply. The tables at the top and right of the drawing show the number of 50 watt lamps to use in order to pass a given amount of current

(This unit designed, tested and all illustrations made in our laboratory)

Interesting Methods of Employment for New Foto Cell Tube

May Be Used with Automatic Relay to Open Garage Doors, or Measure Sunlight or Cloudiness

QUITE recently there appeared on the market a new line of foto electric cells bearing a relatively low list price. This immediately opened up a new field for the use of the foto electric cell and a new prospective field of income for the professional set builder. There are a great many things for which a foto electric cell may be used to good advantage, and inasmuch as the majority of circuits in which the foto electric cell is used, the amount and the type of the apparatus necessary in using this tube is of such nature that the prices of same are quite low, thus making some very attractively priced instruments which may be readily sold at a good profit by the professional set builder. A very satisfactory arrangement, which is illustrated in this article, is a means by which garage doors of a public or a private garage, which are now operated by some sort of an electrical opening and closing device, may be automatically opened through the medium of the headlights of the automobile shining on the foto electric cell.

How It Works

As will be noticed in the wiring diagram, there are three tubes used, a 280 rectifier tube, an 874 voltage regulator and a 226 actuating tube. The filaments of the 280 and the 226 are run from a Thordarson 2445 filament transformer. Inasmuch as the 226 tube operates very satisfactorily on 90 volts, it is not necessary to have a high voltage transformer for plate voltage, and therefore the alternating current is taken directly from the line, rectified by

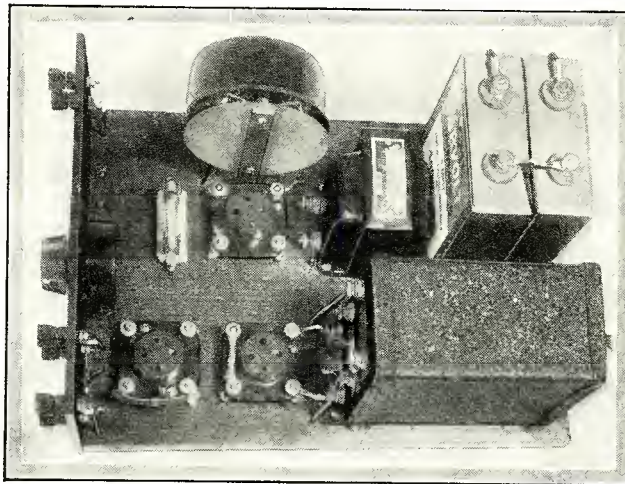

Fig. 1. This photograph shows the completed power supply and automatic relay used with the Foto Cell

the 280 and fed into the plate of the 226 through a filter system, which consists of a 30 henry choke and two 4 mfd condensers. The glow tube is placed across the output of the filter system for the regulation of the output voltage. Inasmuch as line voltages in various communities vary between 90 and 120 volts at different times of the day and night, this tube is of a very valuable nature in this portion of the circuit, inasmuch as the foto electric cell current is adjusted very minutely to a very close margin with the actuating current of the relay. If the voltage rises, the current in the plate circuit of the tube would likewise rise and the relay would trip, which is not at all desirable. By placing the glow tube in the out-

put of the filter circuit, regulation is obtained so that between a voltage variation of 90 and 120 volts there are only two to three volts change in the plate voltage as impressed on the tube. There is placed across the filament of the 226 tube a 10 ohm center tapped resistance, which has a 2000 ohm variable resistance connected to the center tap and to the B negative line, which controls the tube bias on the grid of this tube. This is the only adjustment necessary for the regulation of the plate current in this particular type of circuit. The relay used in this instrument is one of special design by the Yaxley Mfg. Co. of Chicago. It is so designed that if a current of 6 milliamperes passes through the winding, the arm is attracted and the contact closed. The present switch on the electrically operated doors is con-

(Continued on page 133)

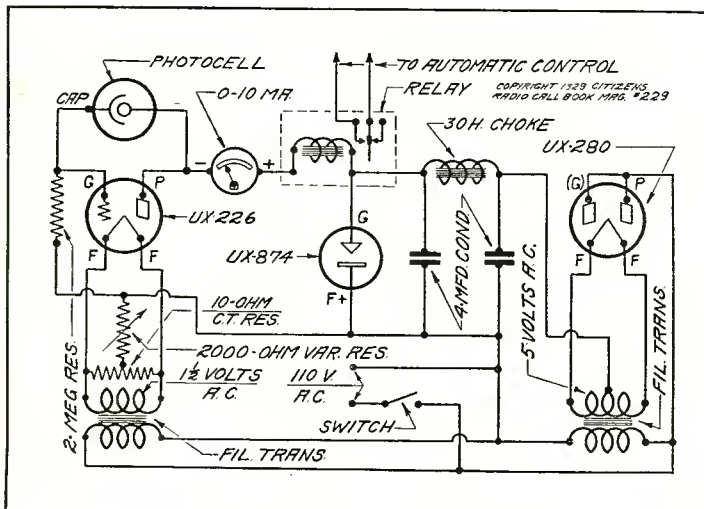

Fig. 2. The schematic circuit used is illustrated above

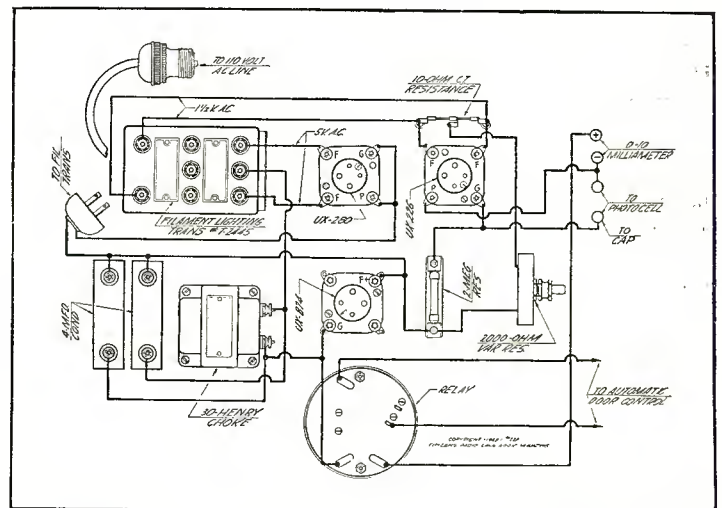

Fig. 3. By means of this graphic a layman can wire up the unit described in this article

(This device designed, tested and all illustrations made in our laboratories)

Optional Connections for Use With Muter Dynamic Speakers

Interesting Information Given in New Booklet Which Helps Service and Repair Men

NEARLY every possessor of a dynamic speaker has at one time or another wondered whether his speaker was connected to the radio set in the proper manner. While it is true that this question might not come up so much in the present-day factory models, where the speaker and the receiver are a part of the console and where each is designed for the other, nevertheless in the custom built job or in the replacement cases where an individual has replaced a magnetic speaker with a dynamic, the user is certain to wish to be sure of himself on this subject.

Muter Issues Instructions

Not all of the dynamic manufacturers take this matter into consideration in the preparation of literature showing the installation and operation of their speakers. However, we note that the Muter interests have taken all of this into consideration and have prepared an eight-page pamphlet giving much helpful information to guide the purchaser of a Muter speaker in making sure that it is connected so as to produce the best results.

In the diagrams shown on this page and in the succeeding text are illustrated several of the optional connections that may be employed to secure maximum effect from the speaker. In the drawing in Fig. 1 it will be readily seen that a dynamic is connected directly into the plate circuit of a 171, 210 or 250 power tube. In this case the plate current from the power tube passes through the primary windings of the input transformer inside of the dynamic housing. This transformer then passes the alter-

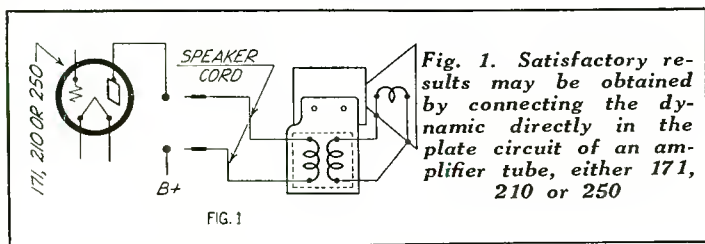

nating current fluctuations in the primary into the secondary, where they are impressed upon the voice coil of the speaker. This type of connection is quite satisfactory for practically all purposes, except where the plate current drawn by the power tube is in excess of the safe current handling capacity of the primary winding in the dynamic speaker itself.

When an individual is using an output transformer in the power stage, regardless of whether it is a 171, 210 or 250, and then taking the output of the secondary and feeding it into the primary of the dynamic input transformer there is a possibility the best results will not be achieved. Under some conditions, largely depending upon electrical characteristics of the transformer, operation will be satisfactory. However, there are occasions when such will not be the case, and in that event it is best to revert to the scheme of connections shown in Fig. 1, eliminating the output transformer in the radio receiver.

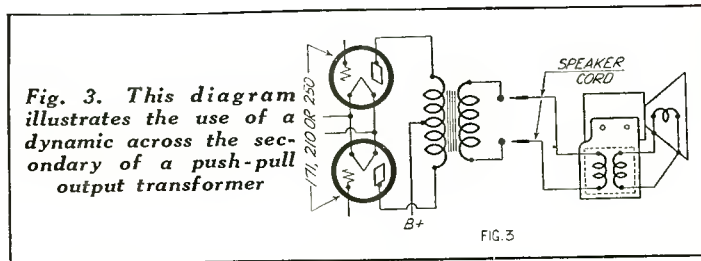
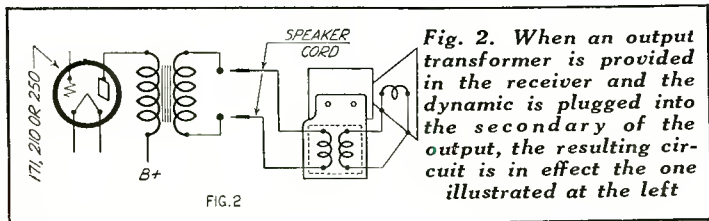

In Fig. 3 we have a push-pull output transformer whose secondary feeds directly into the primary of the dynamic input transformer. Here again there is a possibility that, due to the electrical characteristics of the output transformer, satisfactory results will not be secured. However, in this case it is not possible to put through the primary of the dynamic input the plate current in a push-pull circuit, so another method has to be employed, one of these methods being the one described in Fig. 4 and the other being illustrated in Fig. 5.

Try Several Methods

It will depend largely on the individual user as to which method is most satisfactory. In some cases the presence of the secondary of the push-pull output transformer in the circuit will contribute to distortion. Generally speaking, the idea outlined in Fig. 5 is

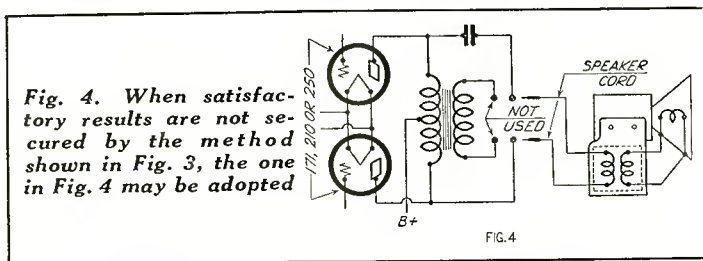

most satisfactory, when it is desired to retain the push-pull output transformer.

Still another method of coupling the push-pull circuit is outlined in Fig. 6, where an output impedance is employed with a center tap, and a 4 mfd condenser is utilized in series with one side of the primary of the dynamic input transformer.

With the number of input connections shown in the diagrams in this article, it is possible for any user of a dynamic to readily determine which method of connection gives the most satisfactory results.

In order to obtain best performance all dynamic speakers must be used with a suitable baffleboard. In the case of the Muter

(Continued on page 130)

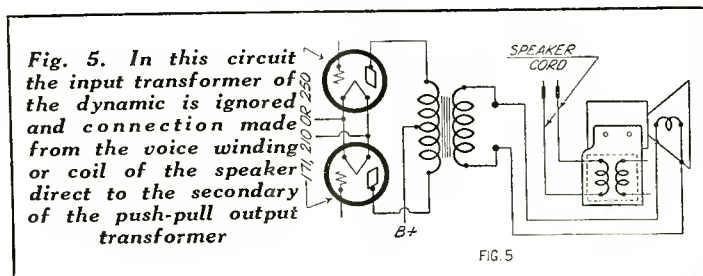

Many Measurements May Be Made with Citizens Grid Dip Meter

Engineering Department Gives in This Article Full Data So Most Benefit Is Secured

IN the past we have made an attempt to show the professional set builder how he could build various instruments for use in his laboratory. Our aim in doing this was to enable the set builder and service man to have methods and means to cope with the great majority of the technical problems he is confronted with and also to broaden the scope of his technical knowledge.

In the following article we have attempted to show how the grid-dip oscillator, as illustrated in the November issue, pages 94, 95, may be used to make measurements, on inductances which are at times very valuable to the experimenter.

What Is Needed

The instruments necessary to make the following measurements are the grid-dip oscillator, having a range of fifteen to six hundred meters, a wavemeter and a standard condenser.

The wavemeter should also cover fifteen to six hundred meters and should be fairly accurate. We would suggest the General Radio Type 358. An extra coil should be purchased to cover the broadcast band. This wavemeter is compact and sturdy and the accuracy is sufficient for use in the home laboratory.

The standard condenser should be of a good make and of constant characteristics. A 1000 mmf (.001 mfd) is the most satisfactory size. We suggest the General Radio Type 239-E condenser for this use. This condenser has end plates and condenser plates of aluminum. The rotor plates are so shaped as to give a nearly constant relation between wavelength and angular variation. The rotor bearings are in direct contact with the end plates. The stator is supported from strips of hard rubber, so placed that the field through them is weak, and practically unvarying for different capacity settings. The rotor turns in locked cone bearings and is counterweighted. A slow motion gear is also supplied. The equivalent series resistance of this condenser is only twelve ohms at 1000 cycles at the 1000 mmf setting. A ten point calibration will be supplied with these condensers at a slight additional cost. The usual condenser as built for broadcast receivers will not be satisfactory for use as a standard condenser.

The following measurements may be made quite satisfactorily with the foregoing apparatus: capacity of variable condensers; (a rather roundabout method is required for these measurements but is quite satisfactory); pure inductance; apparent inductance; distributed capacity of inductances, and the fundamental frequency of inductances.

It is well to caution the experimenter that in order to obtain accu-

rate results from his measurements extreme care must be taken in the making of measurements and a great deal of patience is necessary in doing measurement work, especially those made with radio frequencies. After a little experience the experimenter will be able to foresee precautions and obstacles and take steps to overcome them.

Symbols Used

In the following measurements and calculations the following symbols and their meanings are used:

- L = Inductance
- C = Capacity
- C_s = Capacity standard
- C_x = Unknown capacity
- C_a = Distributed capacity
- π = 3.1416
- C_T = Total capacity
- L_p = Pure inductance
- L_a = Apparent inductance
- λ = Wavelength in meters
- KC = Frequency in kilocycles
- f = Frequency

Four Constants in R. F.

In a radio frequency circuit there are four constants which enter into the design and operation of such a circuit. These constants are inductance, capacity, resistance and frequency. There are also resulting from these constants reactance and impedance, but the latter two will not be discussed in this article. Pure inductance is the inductance which may be derived from calculations of the geometric shape of the coil or measurements of same at 1000 cycles. Capacity is a well known factor and will not be discussed. Resistance, while an important factor in the design and operation of a radio frequency circuit, has no direct connection with the measurements made in this article, so will be discussed in a future issue. Apparent inductance is the amount of inductance which appears to be

present when operated at radio frequencies. Distributed capacity is the amount of capacity between turns of the inductance. The pure inductance plus the distributed capacity results in apparent inductance. The distributed capacity of an average inductance if used in broadcast receivers is very small, usually between 1 and 15 mmf, but if neglected will usually cause inaccuracies of several hundred per cent, and for this reason in the design of the r. f. inductances it is necessary to take distributed capacity into consideration. It is due to this distributed capacity that a coil will respond to a certain wavelength, that is, it will be resonant to a certain frequency. This is called the fundamental wavelength or fundamental frequency.

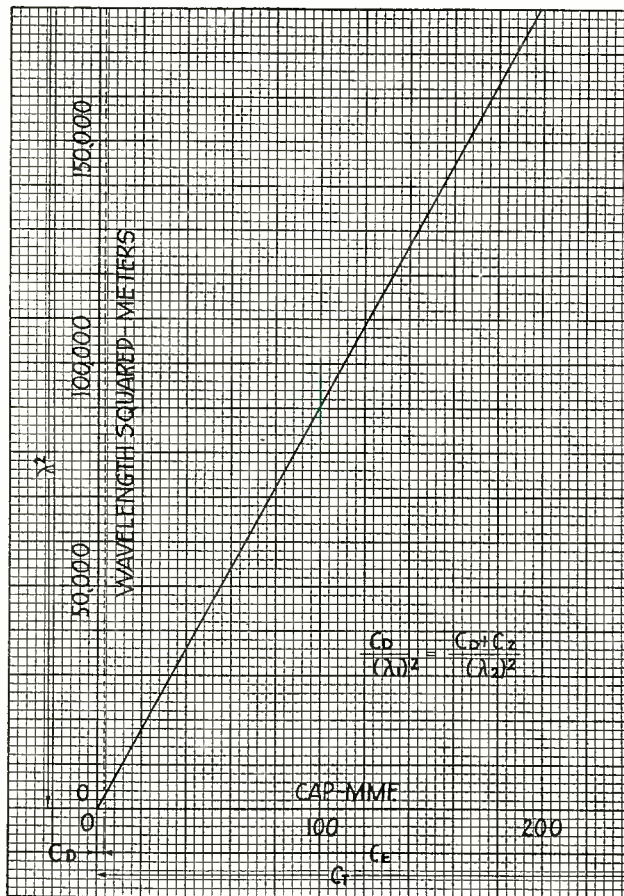

Fig. A. The graph illustrated above shows the relationship between capacity and wavelength squared. Its use is explained in the accompanying article

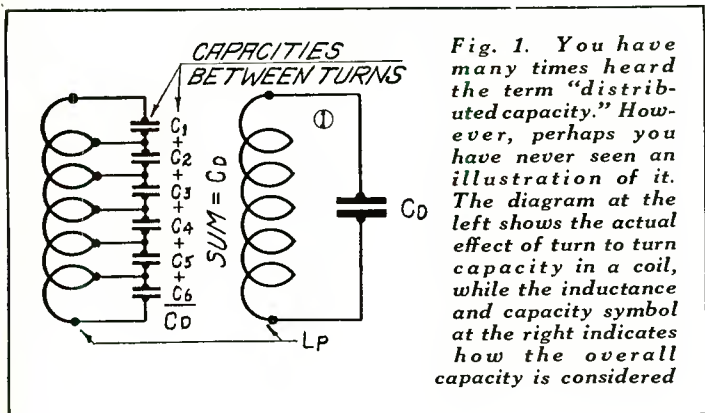

Fig. 1. You have many times heard the term "distributed capacity." However, perhaps you have never seen an illustration of it. The diagram at the left shows the actual effect of turn to turn capacity in a coil, while the inductance and capacity symbol at the right indicates how the overall capacity is considered

Characteristics of Coils

Two coils may have the same pure inductance and yet the apparent inductance may be different, due to different distributed capacities. This inductance (apparent inductance) is computed by regarding the coil and distributed capacity as a pure inductance. A condenser is placed across the coil and the resonance point found. The distributed capacity is disregarded and the capacity of the external condenser is divided into the LC for the wavelength. This result is the apparent inductance. Capacity and inductance will vary with frequency, temperature, current, etc., but the variation is so minute that it will be very difficult to discern in ordinary measurement work.

Meter as R. F. Driver

The grid oscillator is used as a driver to set up induced voltages into the inductances to be measured. The oscillator is tuned to resonance with the coils by means of the tuning dial on the oscillator. Resonance is indicated by the dip of the meter on the oscillator. When the maximum downward deflection of the meter needle is produced, the oscillator is at a wavelength equal to the resonant wavelength of the (coil plus distributed capacity plus external capacity) circuit. If the oscillator coil is too near the coil to be measured, two dips close together on the dial will be produced. To remedy this, move the coils farther apart until only one dip is noticeable.

A coil having a certain fundamental will also have harmonics, that is, it will also respond to certain other frequencies. However, the response to these harmonic frequencies is much less than to the fundamental, therefore the dips encountered by these harmonics are much smaller in depth than the one caused by the fundamental.

Since we can make the oscillator oscillate at the resonant frequency of the coil condenser circuit under measurement, by measuring the oscillator frequency with a wavemeter, we have the circuit fundamental. The wavemeter coil is coupled to the oscillator coil and the dip of the meter is similarly found by tuning the wavemeter condenser instead of the oscillator condenser. By referring to the calibration chart of the wavemeter, the frequency and wavelength may be determined.

The calibrated standard condenser is used for comparison of unknown capacities and in circuit where a known capacity is used for the purpose of calculation.

Some Measurement Work

The following measurements were made in the laboratory and the results and methods shown here:

Referring to Fig. No. 1, the fundamental of the coil was measured. The coil was placed in the field of the oscillator coil and by turning the oscillator dial, the greatest dip on the meter was noted. (After the greatest dip is found, the coil should be moved farther from the oscillator so that the dip becomes sharper.) The coil is then removed from the field and the wavemeter placed in the field of the oscillator and turned for maximum dip of the meter.

The calibration chart of the wavemeter was then referred to and the wavelength was found to be 50 meters, or a frequency of 6000 k. c. This is the fundamental wavelength or the fundamental frequency of this coil. In the measurement of the coil harmonics, the above measurement was repeated, but after finding the fundamental, the oscillator was tuned to a higher frequency until another dip was noted.

This dip was a harmonic of the fundamental. The dip of the harmonic will not be as great as the dip of the fundamental. The result was a wavelength of 25 meters or a frequency of 12,000 k. c. This represents the second harmonic of the fundamental for this coil.

Distributed Capacity

The fundamental of a radio frequency choke coil was measured in the same manner as the foregoing measurements and the fundamental wavelength was found to be 765 meters or a frequency of 392 k. c. In the measurement of the distributed capacity (C_d) of a coil, refer to Fig. 2-A and find the fundamental wavelength (λ_1), as has been done in the previous measurements. The coil measured in the laboratory was found to have a fundamental wavelength of 50 meters. The standard condenser (C_s) was then placed across the coil as in circuit 2-B. The standard condenser was then set at 100 mmf. The oscillator was then tuned to resonance with this circuit, but, of course, it is of a higher wavelength (lower frequency). The fundamental of this circuit (λ_2) was equal to 308 meters. The following formula was then used to find the distributed capacity of the coil.

$$\begin{aligned} C_d &= \frac{C_d + C_s}{(\lambda_1)^2} = \frac{C_d + 100}{(50)^2} \\ &= \frac{94264}{94264C_d} = \frac{2500C_d + 250000}{94264C_d - 2500C_d} = \frac{250000}{91764C_d} \\ C_d &= 2.7 \text{ mmf} \end{aligned}$$

The above problem was worked out from the figures given and the distributed capacity for the coil was found to be 2.7 mmf. If the reader will carefully study over this procedure, he will be able to duplicate this measurement with any type of coil. In the measurement of pure inductance (L_p) when distributed capacity, C_d and the external capacity C_s are known.

Referring to Fig. 2, measure the fundamental of the coil (λ_1), as was previously done in Fig. 2-A, the fundamental of this coil as measured before was 50 meters. Then measure the distributed capacity C_d , as in the previous measurement. C_d was 2.7 mmf. Then the standard condenser C_s should be connected as in circuit 2-B. The capacity of the standard condenser C_s was then noted and found to be 350 mmf. The oscillator was tuned to resonance and the fundamental of the circuit was found (λ_2) to be 560 meters. The LC table (oscillation constant) was then referred to for the wavelength of (λ_2) 560 meters and found to be .08836. These figures were applied to the following formula:

$$\begin{aligned} C_d + C_s &= C_T \\ C_d &= .0000027 \\ C_s &= .0003500 \\ C_T &= \frac{.0003527}{LC} \\ L_p &= \frac{C_T}{.08836} \\ L_p &= \frac{.0003527}{.08836} \\ L_p &= 247.1 \end{aligned}$$

The result of these calculations will give the pure inductance (L_p) of the coil, which in this case was found to be 247.1 microhenrys.

Referring to Fig. No. 3, we are measuring the apparent inductance

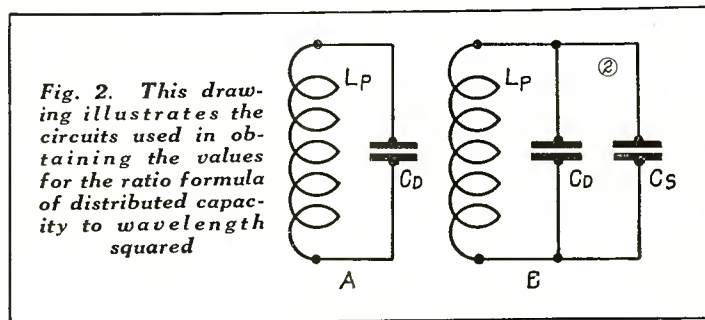

Fig. 2. This drawing illustrates the circuits used in obtaining the values for the ratio formula of distributed capacity to wavelength squared

tance (L_a) when the external capacity C_s is known. Measure the fundamental wavelength (λ_1) as previously done. This was found to be 50 meters. Place the standard condenser C_s across the coil as in Fig. No. 3-A. The capacity of the standard condenser C_s should then be noted. This was found to be 350 mmf. Tune the oscillator to resonance with this circuit for the fundamental wavelength (λ_2) of the circuit. This was found to be 560 meters. Again referring to the LC table, for the LC factor of the wavelength (λ_2) 560 meters. The LC factor was found to be .08836. These figures were then applied to the formula:

$$\begin{aligned} L_a &= \frac{LC}{C_s} \\ &= \frac{.00035}{.08836} \\ &= 252.1 \end{aligned}$$

The result was found to be 252.1 microhenrys, apparent inductance of the coil.

Measuring Unknown Capacity

The next measurement made was the capacity of an unknown condenser (C_x), when the pure inductance L_p and the distributed capacity C_d were known. The same coil in figures as from the previous experiments were used. The pure inductance L_p was 247.1 microhenrys and the distributed capacity C_d was 2.7 mmf. The unknown condenser was then connected across the coil as shown in circuit No. 4. The coil was then placed in the field of the oscillator and the oscillator tuned to resonance or the fundamental wavelength (λ_1) of the circuit. This was found to be 220 meters. The LC chart was again referred to for the wavelength of (λ_1) 220 meters and found to be .01362. These figures were then applied to the formula:

$$\begin{aligned} C_T &= \frac{LC}{L} \\ &= \frac{.01362}{247.1} \\ &= .0001915 \\ C_x &= C_T - C_d \\ C_T &= .0001915 \\ C_d &= .0000027 \\ \hline C_x &= .0001908 \\ &= 190.8 \end{aligned}$$

The capacity of the unknown condenser was 190.8 mmf.

Matching Variable Condensers

In the matching of variable tuning condensers, an arrangement was used as shown in circuit No. 5. The small trimming condensers used as shown in Fig. No. 5. The small trimming condensers and maximum capacity. Then connect one condenser across a coil and find the resonance point. The wavelength of this resonance point should be noted. The second condenser should then be placed across the coil and the oscillator left constant. The trimmer on this condenser should then be adjusted preferably by means of a wooden screw-driver until the same resonance point is found. This may be continued on any number of condensers in a gang. A multi-gang condenser may be matched at any one angular setting, but may not be matched at other angular settings. This is due to the mechanical con-

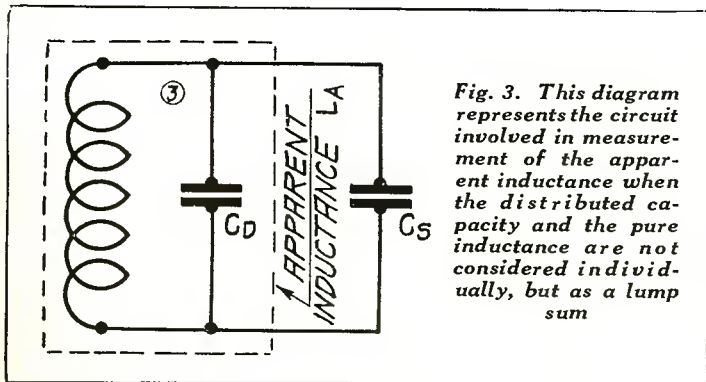

Fig. 3. This diagram represents the circuit involved in measurement of the apparent inductance when the distributed capacity and the pure inductance are not considered individually, but as a lump sum

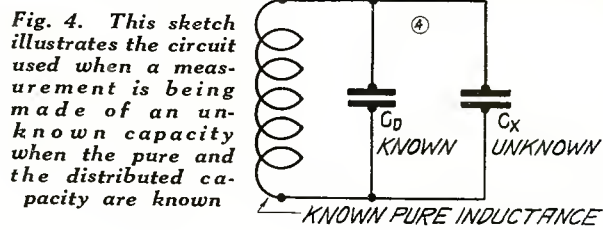

Fig. 4. This sketch illustrates the circuit used when a measurement is being made of an unknown capacity when the pure and the distributed capacity are known

struction. A few of the higher grade condensers now on the market will be found to be within .5 mmf of any other section in any angular setting, but this is a very unusual case. Some gang condensers will be matched at maximum and gradually become unmatched until at minimum two or more of the sections will be as much as 25 mmf more or less than each other.

Coil Measurements

In the matching of coils, there are two methods of making this measurement. Referring to Fig. No. 9, place a coil in the field of the oscillator and tune the oscillator until the fundamental is found. Note the wavelength and dial setting. Place the second coil in the field of the oscillator at exactly the same position and the same place that was taken by the first coil. If, when the resonance point of the coil is found, and found to be higher in wavelength than that of the first, one turn at a time should be removed until the same resonance point is found as in the first coil. In case the second coil has a resonance point lower than that of the first, turns should be taken from the first coil until the resonance point is found to be the same as that of the second. The coils can now be said to be matched. If tuning condenser of equal capacities are placed across each coil, the frequency response of both circuits will be identical provided that the distributed capacities of both coils are the same. The other method of matching coils is to place the condenser across the coil and to find the resonance point at 4 or 5 places on the dial and then place the second coil across the condenser and take turns off until the resonance point is found at the same place on the dial. Most coils of the same construction, that is, the same size tubing, the same size wire and the same insulation, will generally have pure inductances and distributed capacities close enough that they will follow over the band very satisfactorily.

In the article illustrating the grid dip oscillator, there will be noted that two binding posts were provided for a method of modulating the oscillator. When modulated, the grid dip oscillator makes a very convenient and useful method of balancing a tuned radio frequency receiver, that is, it oftentimes happens that one or more of the tuned condensers in the receiver are sufficiently off resonance that the receiver will either be very broad in tuning, which results in weak distance signals, or no signal at all. The oscillator may be very conveniently modulated from a buzzer or an audio oscillator source, having a frequency within the audible range. The procedure for the balancing of a receiver is to turn on the oscillator and the source of modulation and tune the receiver to a wavelength which might come in at about 10 degrees on the dial. Then tune the oscillator until the modulated frequency is heard in the loud speaker. On receivers which are not very sensitive, the oscillator will probably be fairly close to the receiver, but on sensitive receivers, such as superheterodynes and the larger tuned radio frequency receivers, the oscillator may be placed at some distance from the receiver, inasmuch as if it were close the signal would be very broad and very difficult to balance the receiver perfectly. After the signal is heard in the loud speaker, the balancing devices, trimmers or otherwise, may then be turned until the maximum signal is heard. The receiver and oscillator should then be tuned to a higher wavelength, such as one corresponding to 30 degrees on the dial, and the same procedure repeated. This should be done at approximately every 20 degrees on the dial. It oftentimes happens that the receiver will be perfectly balanced at the low end of the scale and be considerably off balance at the high end of the scale. This is due to the gang condensers not tracking alike in capacity variation with

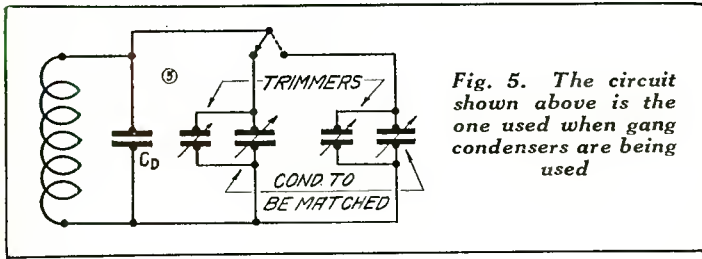

Fig. 5. The circuit shown above is the one used when gang condensers are being used

will have to be moved closer to the receiver to hear the signal. After this is done, the balancing condenser may be adjusted with a wooden screw-driver until little or no signal is heard coming through the receiver. This stage is now neutralized or balanced and the good tube is placed in the socket again and a balancing tube is placed in the second stage of radio frequency and the same procedure repeated, likewise in the following stages, if there are any. After the receiver has been perfectly neutralized or balanced, the oscillator should be turned off and a radio station

WAVELENGTH, FREQUENCY, AND OSCILLATION CONSTANT

Wave-length, Meters	Frequency	LC	Wave-length, Meters	Frequency	LC
1	300,000,000	.0000003	190	1,579,000	.01016
2	150,000,000	.0000011	195	1,538,000	.01071
3	100,000,000	.0000025	200	1,500,000	.01126
4	75,000,000	.0000045	205	1,463,000	.01183
5	60,000,000	.0000070	210	1,429,000	.01241
6	50,000,000	.0000101	215	1,395,000	.01301
7	42,860,000	.0000138	220	1,364,000	.01362
8	37,500,000	.0000180	225	1,333,000	.01425
9	33,333,000	.0000228	230	1,304,000	.01489
10	30,000,000	.0000282	235	1,277,000	.01555
15	20,000,000	.0000634	240	1,250,000	.01622
20	15,000,000	.0001126	245	1,225,000	.01690
25	12,000,000	.0001760	250	1,200,000	.01760
30	10,000,000	.0002533	255	1,177,000	.01831
35	8,571,000	.0003448	260	1,154,000	.01903
40	7,500,000	.0004503	265	1,132,000	.01977
45	6,667,000	.0005700	270	1,111,000	.02052
50	6,000,000	.0007039	275	1,091,000	.02129
55	5,454,000	.0008519	280	1,071,000	.02207
60	5,000,000	.0010114	290	1,034,500	.02366
65	4,615,000	.0011888	295	1,017,000	.02450
70	4,286,000	.0013788	300	1,000,000	.02533
75	4,000,000	.0015833	310	967,700	.02705
80	3,750,000	.0018011	320	937,500	.02883
85	3,529,000	.0020334	330	909,100	.03066
90	3,333,000	.0022829	340	882,400	.03255
95	3,158,000	.0025411	350	857,100	.03448
100	3,000,000	.0028166	360	833,300	.03648
105	2,857,000	.0031055	370	810,800	.03854
110	2,727,000	.0034044	380	789,500	.04065
115	2,609,000	.0037211	390	769,200	.04277
120	2,500,000	.0040522	400	750,000	.04503
125	2,400,000	.0043977	410	731,700	.04733
130	2,308,000	.0047577	420	714,300	.04966
135	2,222,000	.0051300	430	697,700	.05204
140	2,144,000	.0055188	440	687,800	.05446
145	2,069,000	.0059199	450	666,700	.05700
150	2,000,000	.0063355	460	652,200	.05960
155	1,935,000	.0067600	470	638,300	.06219
160	1,875,000	.0072044	480	625,000	.06485
165	1,818,000	.0076622	490	612,200	.06759
170	1,765,000	.0081344	500	600,000	.07039
175	1,714,000	.0086200	510	588,200	.07327
180	1,667,000	.0091200	520	576,900	.07606
185	1,622,000	.0096344	530	566,000	.07905

WAVELENGTH, FREQUENCY, AND OSCILLATION CONSTANT

Wave-length, Meters	Frequency	LC	Wave-length, Meters	Frequency	LC
540	555,600	.08208	990	303,100	.2759
550	545,400	.08519	1,000	300,000	.2816
560	535,700	.08836	1,010	297,000	.2870
570	526,300	.09139	1,020	294,100	.2927
580	517,200	.09467	1,030	291,300	.2986
590	508,500	.09801	1,040	288,400	.3045
600	500,000	.1014	1,050	285,700	.3105
610	491,800	.1047	1,060	283,600	.3161
620	483,900	.1082	1,070	280,400	.3222
630	476,200	.1117	1,080	277,800	.3283
640	468,700	.1154	1,090	275,200	.3345
650	461,500	.1188	1,100	272,700	.3404
660	454,500	.1225	1,110	270,300	.3467
670	447,800	.1263	1,120	267,900	.3531
680	441,200	.1302	1,130	265,500	.3595
690	434,800	.1341	1,140	263,100	.3660
700	428,600	.1378	1,150	260,900	.3721
710	422,500	.1419	1,160	258,600	.3787
720	416,700	.1459	1,170	256,400	.3853
730	411,000	.1501	1,180	254,200	.3921
740	405,400	.1540	1,190	252,100	.3988
750	400,000	.1583	1,200	250,000	.4052
760	394,800	.1626	1,210	247,900	.4121
770	389,600	.1668	1,220	245,900	.4190
780	384,600	.1712	1,230	243,900	.4260
790	379,800	.1756	1,240	241,900	.4326
800	375,000	.1801	1,250	240,000	.4397
810	370,400	.1847	1,260	238,100	.4469
820	365,900	.1893	1,270	236,200	.4541
830	361,400	.1941	1,280	234,400	.4610
840	357,100	.1985	1,290	232,600	.4683
850	352,900	.2034	1,300	230,800	.4757
860	348,800	.2082	1,310	229,000	.4831
870	344,800	.2132	1,320	227,300	.4906
880	340,900	.2179	1,330	225,600	.4978
890	337,100	.2229	1,340	223,900	.5053
900	333,300	.2280	1,350	222,200	.5130
910	329,700	.2332	1,360	220,600	.5208
920	326,100	.2381	1,370	218,900	.5281
930	322,600	.2434	1,380	217,400	.5359
940	319,100	.2487	1,390	215,800	.5438
950	315,900	.2541	1,400	214,300	.5518
960	312,500	.2595	1,410	212,800	.5598
970	309,300	.2647	1,420	211,300	.5674
980	306,100	.2704	1,430	209,800	.5755

dial settings, and there is practically no remedy for this condition. It would very probably be the best plan in a receiver of this type to balance it perfectly at 50 degrees on the dial and trust to luck that it will follow very closely at zero degrees and also at 100 degrees.

In the neutralizing of receivers which use the Neutrodyne circuit, neutralized feed back, inductance bridge circuit or capacity bridge circuit, a little different procedure is necessary. It is very convenient to take the type of tube which is used in a radio frequency amplifier of these receivers and saw off one of the filament prongs, so that it will not make contact in the socket. The receiver is tuned to approximately 10 degrees on the dial and the oscillator tuned to resonance until the signal is heard in the loud speaker. Very careful tuning of the receiver for this adjustment is necessary. After the receiver is adjusted as close as possible to resonance with the oscillator, the tube in the first stage of radio frequency should be removed and the tube with the sawed-off filament prong should be inserted. The signal now, of course, will be considerably weaker and it is possible that the oscillator

tuned in on the low wavelengths and the volume turned up as high as possible to see if the receiver will oscillate at these frequencies. It does not very often happen that if the receiver will not oscillate on the low waves that it will oscillate on the high waves. It may require a little time on the part of the experimenter to determine the exact and best procedure to follow in the balancing and neutralizing of the various types of receivers which he is working with.

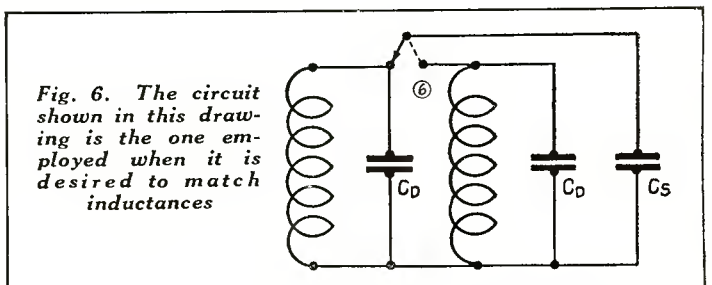

Fig. 6. The circuit shown in this drawing is the one employed when it is desired to match inductances

The ABC of Radio

IN the January issue of this magazine an error was made in the descriptive matter covering sketch C on page 94. It was stated that Fig. 3 shows where one wire passes over the other without any connection being made. This is in error. It should read "Fig. 3 indicates a solder joint, while Fig. 4 shows one wire passing over another without any connection being made."

Push-Pull Amplification

SO MUCH is heard nowadays about the term "push-pull" that perhaps some of the lay readers of this publication might wonder at the significance of the name. Push-pull is a very apt description of what transpires in a radio circuit when two

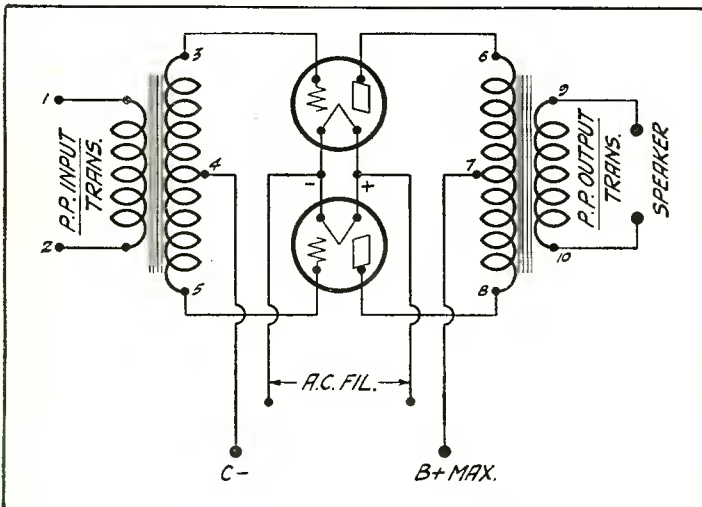

Fig. 1

tubes are arranged as they are called in "push-pull." In reality it means that while one tube is working in one direction the other tube is working in the opposite direction and their united efforts at the output side are additive. Thus, in the diagram, Fig. 1, we have a push-pull input transformer, consisting of a primary designated as 1 and 2, and a center tapped secondary designated as 3, 4 and 5. Terminal 4 is the center tap of the inductance and goes to the negative C battery. Terminal 3 of the secondary goes to the grid of one tube, while terminal 5 goes to the grid of the second tube. When an alternating current is impressed on the primary of the push-pull input across 1 and 2, it induces an a. c. current in the secondary. This secondary then passes the current along to the two grids of the tubes placed in push-pull. While one of the grids operates during one half of the cycle, the second grid operates during the opposite half of the cycle. By this process the plate circuit of the tube will have the same characteristic as the grid circuit, that is, there will be energy from plate during one half of the cycle and from the other plate during the other half of the cycle. On account of the linking together of the two plates to a center tapper plate coil, such as illustrated in Fig. 1 and designated by terminals 6, 7 and 8, it is possible to get a true alternating current through the device with twice the current passing that would normally be expected if only one tube were operating. In the case of the terminal 7, it is the connection for the plate current, while terminal 6 goes to one plate and

terminal 8 to another. The alternating current fluctuations induced in the primary of this push-pull output transformer are then passed into the secondary of the push-pull, whose terminals are designated by the numbers 9 and 10 and across whose extremities is placed the speaker, regardless of whether it is a dynamic or a magnetic cone.

Idea Known for Years

There is nothing new or novel about push-pull, since the idea has been known to electrical workers for a good many years. However, it has come into considerable use lately because of the fact that larger output currents may be anticipated with a decrease in the tendency towards distortion. Also another reason for its adoption is the fact that two stages in push-pull may use a much lower plate current than one single stage, using a larger power tube. For example: two 171's in push-pull would probably be equal to a single 210, with the advantage in favor of the 171's in push-pull, in that the plate voltage need not be as high on these tubes as it would be on the 210 tubes.

It will be found in practice that the output transformer shown in Fig. 1 as a push-pull output transformer is the one that is used by most manufacturers and set builders when it is desired to operate a magnetic speaker. In this case the secondary winding of the output transformer goes directly to the two terminals of the magnetic speaker. While it is possible to operate a dynamic speaker with its own input transformer off of the output sec-

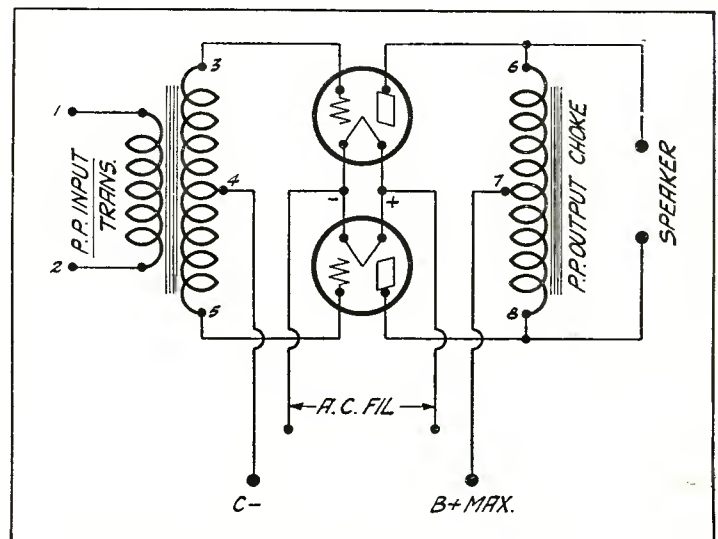

Fig. 2

ondary, nevertheless, unless each transformer has been made for the other, there is a possibility that distortion will result. As a consequence, the magnetic has more favor when connected with the output transformer. When a dynamic is used, then another method of connection may be employed, such as is illustrated in Fig. 2, which will be described in the following paragraph.

The diagram in Fig. 2 represents a push-pull input stage and a push-pull output impedance instead of an output transformer. The principles underlying the operation of the grid and plate circuit are identical in this case with those illustrated in Fig. 1. However, in the case of the output choke or the output imped-

ance, many builders prefer to use the speaker across the two extremities of the output impedance. In this particular case it is possible to use the input transformer of the dynamic speaker directly across the output terminal.

Still another method of coupling in the speaker may be adapted if desired, this method consisting of placing a 4 mfd condenser in series with one lead of the speaker so that the speaker windings will not be magnetically coupled across terminals 6 and 8 in Fig. 2, but will be capacitatively coupled through the 4 mfd con-

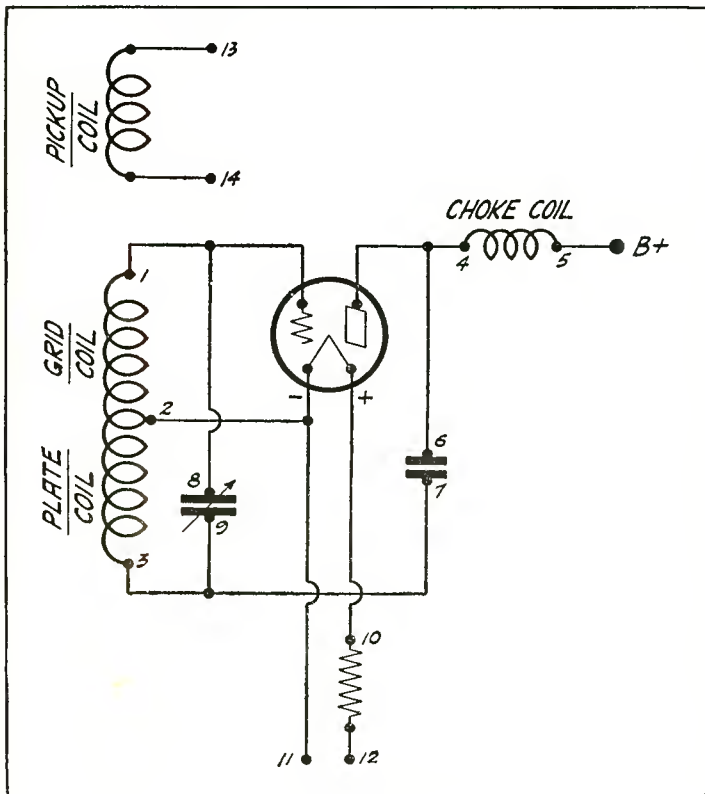

Fig. 3

denser, which is used in series with one of the speaker leads. There is a question as to which method is best, and oftentimes only a trial will determine.

If the reader is interested in the methods of connection for dynamic speakers, we would suggest that he refer to the article appearing on page 85 of this issue concerning optional connections for the dynamic speaker. In that article there are a number of diagrams and explanatory texts showing exactly how the individual user of a dynamic may connect the speaker until he secures the best results possible.

What Is an Oscillator?

READERS have often seen schematic diagrams of superheterodynes in this publication and some of these readers have expressed an interest as to what constitutes an oscillator and what its function is. We are showing in the diagram marked Fig. 3 the electrical circuit of an oscillator of one type. Of course there are other types of tuning methods employed in an oscillator, but we are using this one, since it seems most generally used. The inductance from 1 to 3 constitutes the tuning range of the oscillator coil, and this inductance is tuned by means of the variable condenser designated at 8 and 9. The center tap of this inductance is at point 2. That portion of the inductance between point 2 and 1 represents the grid section of the oscillator circuit, while the portion from 2 to terminal 3 represents the plate section. Oscillation is created in the circuit by means of the fixed condenser located at 6 and 7. This capacity is not critical. In some supers it is .006 and in others it is .002, depending entirely on the construction of the inductance. When the condenser 8

and 9 is at its minimum setting, the oscillator produces a radio frequency carrier of the lowest wavelength. The highest wavelength covered by the oscillator coil is when the plates of the variable condenser are fully meshed. In general practice the wavelength of the oscillator coil is a little under the wavelength range of the antenna or loop stage.

A Miniature Transmitter

A choke coil at points 4 and 5 is inserted between the plate of the oscillator and the B battery potential in order to prevent any radio frequency energy from going back through the battery system. When the filament is lighted and the plate potential applied, the oscillator becomes in effect the very miniature transmitter, whose frequency energy is usually sufficient only to modulate or mix in with the signal in the superheterodyne. In order to get the radio frequency energy out from the oscillator circuit and into the first detector of the superheterodyne, it is necessary to employ a pick-up coil, which is designated as lying between terminals 13 and 14. This pick-up coil is inductively related to the grid or plate coil, depending upon the design of the inductance. In many cases the pick-up coil is variable, so that the operator may have an opportunity of governing at will the amount of pick-up taken from the oscillator. However, in latter-day practice, the pick-up coil is generally made of a fixed nature, so that no adjustment becomes necessary on the part of the operator.

In the superheterodyne the incoming signal frequency is detected by the first detector and then the frequency of the oscillator is mixed with the incoming signal frequency in the first detector stage, and in that mixed form it passes into the intermediate frequency amplifier section, where it is amplified at a wavelength usually in excess of the wavelength of the incoming signal. At the end of the intermediate amplifier train is the second detector, where the energy is detected for the second time and then amplified at audio frequencies.

Signals Are Mixed

The pick-up coil in practically every design of which we know is located in series with the grid return of the first detector. In this position the relatively weak impulses from the oscillator can readily mix with the incoming signal impulses in the grid circuit of the first detector, so that when the plate circuit of that tube is reached, the mixed frequency will be found. In the early days of superheterodyne design it was generally felt that best results were secured with the then existing type of tube if the intermediate amplification was accomplished at a wavelength considerably in excess of the incoming signal wavelength. For that reason it was not uncommon to see intermediate frequency transformers with a wavelength fundamental of 3000 to 5000 meters. Later on as methods of controlling oscillation tendency of amplifier tubes became more perfected it was possible to keep on reducing the intermediate wavelength fundamental until at the present time with the screen grid tubes, where there is no possibility of feed back within the tubes, we now find that intermediate amplification is accomplished almost at the signal wavelength. If we are to judge from the past and attempt to make a prediction for the future, it is not very difficult to see where two or three years from now the superheterodyne idea might be abandoned because results equally as good, if not better, might be anticipated from cascaded stages of tuned radio frequency. In this case, the oscillator tube could be eliminated as an oscillator and could take its place as a tuned radio frequency stage by being placed in the proper position.

Arguments as to Merits

There has always been and probably always will be an argument between the advocates of the super and the advocates of the tuned radio frequency. From the manufacturing standpoint, it would seem that the tuned radio frequency has the advantage, since it may be more simplified than the super. Then again it is possible with the screen grid tubes now available to get a much higher degree of amplification than was ever possible before, and in fact this amplification may be carried to the point where the

(Continued on page 135)

SERVICE and REPAIR notes

IN CREATING the department with the heading shown above, we have acceded to the demands of many service men who are frequently faced with the necessity of doing service work on a receiver, only to find that they did not have a schematic diagram of that particular model. We believe that the publication of the schematic diagrams of the more popular receivers will be helpful in enabling the service man to expedite his test work. We would like to have the views of service men on this subject and would suggest that they refer to page 117, where the questionnaire appears, and give us the benefit thereon of any suggestions they have may concerning this subject.

Acme AC7 and AC4

Schematically in Fig. 1 we are showing the electrical circuit of the Acme a. c. 7, manufactured by the Acme Electric & Mfg. Co. of Cleveland, Ohio. The six tube circuit is the one illustrated in Fig. 1, and it includes a power pack. The power equipment is completely enclosed in metal, and the rectifier tube is mounted on the main chassis of the set, near the front panel so as to have ample cooling space. The power pack consists of a type 280 full wave rectifier tube, with power transformer having a split 440 volt secondary, making the effective voltage at the output end of the filter approximately 200 volts. Filament windings for the a. c. receiving tubes are also included in the power transformer. The electrical center of the filament circuit for both the r. f. and first audio tubes is obtained by means of a slide wire resistor.

Aperiodic Antenna

The schematic shows that the antenna circuit is aperiodic and untuned, the first tube acting as a low gain isolating tube between the antenna and r. f. amplifier, which is controlled or tuned

by means of a three gang condenser. Volume control is secured by means of a potentiometer shunted across the secondary of the first audio transformer. The grid circuit of the second and third 226 tubes has an individual limiting resistor, which is used as a method of stabilization. In the detector a 227 is employed, while the output tube of the receiver is a 171-A. Four of the 226 tubes are operated from a 1.5 volt a. c. winding, the 171-A secures its filament supply from the 5 volt winding, all of these secondaries being located in the power supply housing. The pilot lamp is placed in parallel across the 5 volt secondary. The resistance network across the output of the filter consists of a 2500 ohm section, a 12,000 ohm section and a third section of 20,000 ohms. This makes a total of 34,500 ohms. A filter capacity of 2 mfd is supplied at the input to the choke, while a 3 mfd condenser is used at output side of the choke.

Switch for Line Variations

A switch is provided in the 110 volt a. c. line for turning on and off the receiver. It is also possible to take advantage of light line changes by means of an optional connection, turning the switch from either 105 volt in case the line is high, or turning the switch to 115 volts in case the light line voltage is low. This gives a flexibility of control which is quite helpful in instances where there is liable to be any fluctuation in line voltages especially where such fluctuation persists over a fairly long period of time.

Another one of the models marketed by the Acme interests is illustrated schematically in Fig. 2. This model receiver is intended for local reception and for that reason it consists merely of a 227 detector of the non-regenerative type, with a 112-A first detector and a 112-A power tube. By the employment of the 112-A tube, considerably more audio amplification is secured.

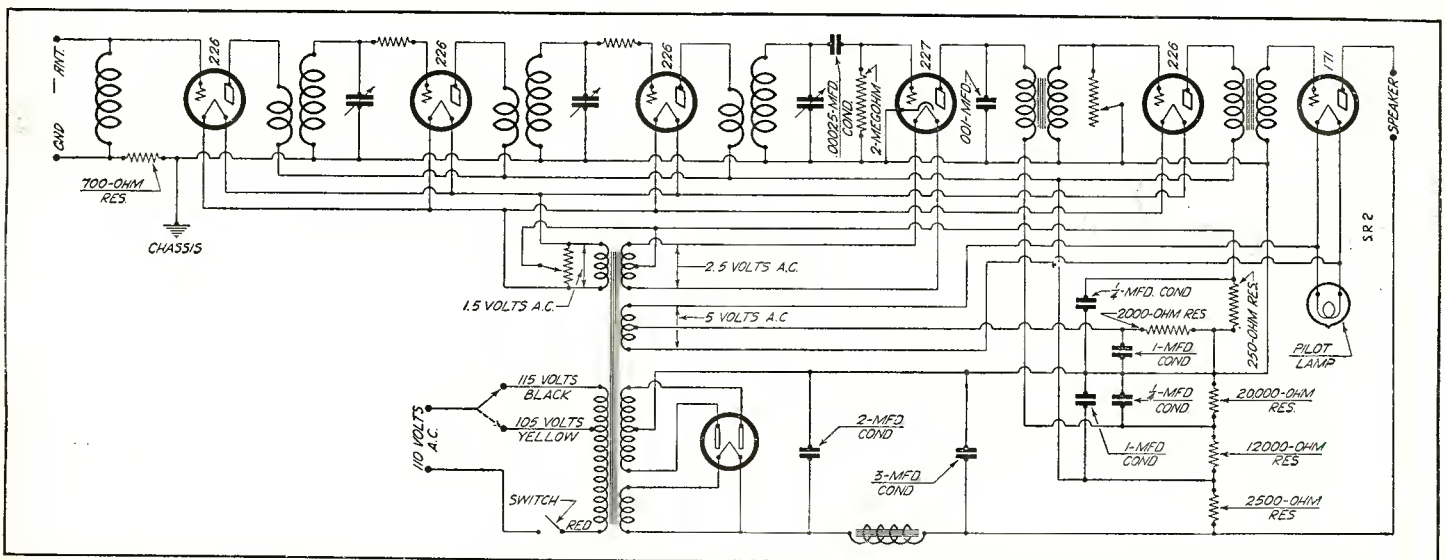

Fig. 1. In this diagram is presented the schematic circuit of the Acme A. C. 7, which has three stages of tuned r. f. amplification using 226 a. c. tubes, a heater detector 227, a 226 first audio stage and a power output tube where a 171-A is employed

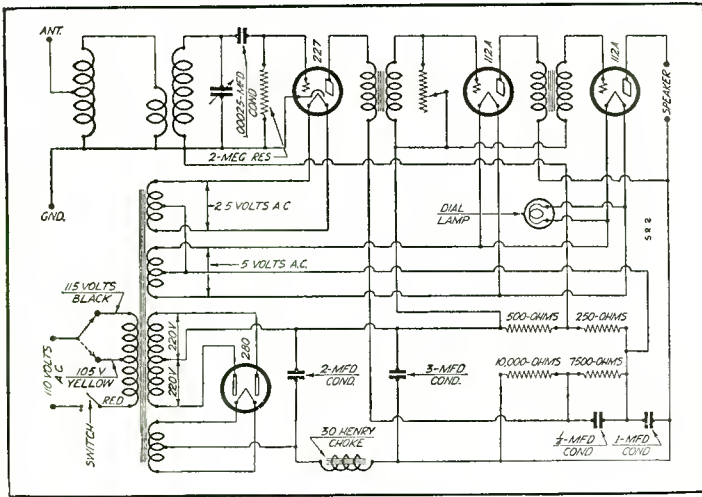

Fig. 2. This diagram represents the schematic of the Acme A.C. 4, which is intended for local reception and comprises a non-regenerative detector using a 227, a first stage audio using a 112-A and the power stage also being a 112-A

The power plant for the receiver is also shown schematically in Fig. 2, where it will be seen to consist of a 280 rectifier with the conventional 30 henry choke and the filter capacity. Plate supply and C bias for the tubes is taken off from taps on a resistance network across the output of the filter. As in the other models, a switching arrangement is provided whereby the user may take advantage of the opportunity to operate the receiver either on 115 volts or 105 volts depending upon the line conditions.

All-American Mohawk 6-8 Models

ANOTHER receiver whose electrical characteristics are being diagrammed and explained in this section is that made by the All-American Mohawk Corp. of Chicago. Their model using eight tubes is shown in the schematic diagram, Fig. 3, while the six tube model is shown in Fig. 4. Fig 5 gives the schematic details of the power supply for both the six and eight tube receivers.

The eight tube receiver consists of four stages of radio frequency amplification, one stage of which is untuned, a detector, one stage of straight audio amplification, one stage of push-pull power amplification using 171-A tubes. Two 227 tubes are employed, one being in the detector and the other in the first stage of audio. The remaining three tubes are of the 226 type.

For the benefit of service men, we are making some excerpts from the service manual furnished by the All-American Mohawk

Corp.

Looking at the receiver from the top front may be seen the four gang condenser. Located between the units of this condenser are the single adjustable plates for matching this condenser, so that the whole condenser unit will be matched. Mounted on the side of the condenser will be seen the small plates which comprise the balancing condenser to balance the receiver. There are two sets of balancing condenser on this four gang condenser. This gang condenser is supported on the main sub-base by means of nuts and screws. It may be removed from the chassis frame by removing the three nuts on the under side of the chassis.

To the left of the condenser are the audio units. The first enclosed units is the first stage transformer. Next to it is the case containing the push-pull input and output unit. Mounted on top of the chassis by screws and nuts, these units are removable by unsoldering the leads underneath and removing the nuts and screws holding the can.

Power Supply

To the rear of the chassis is mounted the power unit. The power unit for the eight tube receiver is identical in appearance and description to the six tube model. The difference between the power units of these models is merely in the circuit arrangement. The eight tube requires a higher B supply output, which is obtained by means of the voltage tap on the transformer supplying the plates of the rectifier tubes. This will be seen by consulting the schematic diagram shown in Fig. 5.

Viewing this chassis from the bottom side, may be seen the base assembly and wiring. The r. f. coil assembly is fastened to the chassis by means of three screws along side the front end of the chassis. Mounted on the bakelite socket strip will be seen the untuned r. f. transformer coil. Along side of this coil will be seen the balancing condenser for balancing the first tube against oscillation. This consists of two small brass plates separated by an insulating strip. This condenser is adjusted by bending its plates close together or further apart, as conditions may require.

Connected to the grid socket terminal of the first tube may be seen a small flexible resistance unit. This is the 800 ohm grid resistor used in the first r. f. stage. Connected across the filament socket terminals of the four r. f. tubes is the 6 ohm center tapped resistance for these tubes. Connected to the center of this resistance and ground is another flexible resistance unit. This is the 400 ohm grid bias resistance for the r. f. stages. Connected across the "phono" or electrical pick-up jack will be seen two tubular resistances. The yellow unit is the 1/2 megohm unit and the black one is the 2 megohm unit for the grid leak. The tap for the grid socket terminal of the detector is a .00025 grid condenser. Con-

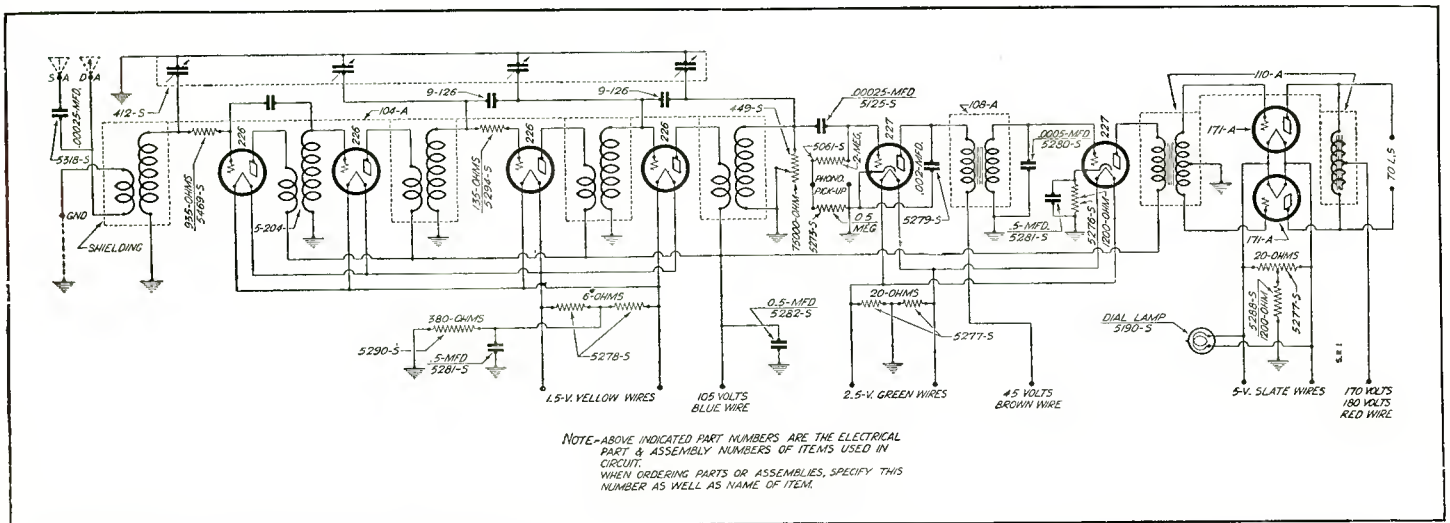

NOTE-ABOVE INDICATED PART NUMBERS ARE THE ELECTRICAL PART & ASSEMBLY NUMBERS OF ITEMS USED IN CIRCUIT. WHEN ORDERING PARTS OR ASSEMBLIES, SPECIFY THIS NUMBER AS WELL AS NAME OF ITEM.

Fig. 3. The All-American Mohawk Corp. 8 tube a.c. set is diagrammed schematically above. This receiver consists of four stages of radio frequency amplification, one stage of which is untuned, one stage of straight audio amplification and one stage of push-pull power amplification, two 171 tubes being employed in the push-pull output

Same Pack for Both Models

Referring to the schematic diagram of the power supply shown in Fig. 5, it will be noted that the only difference between the units for the six and eight sets is the voltage applied to the plates of the rectifier tubes. In other words, just changing these two connections from one point to the other is all that is necessary to change from a six tube to an eight tube power unit. In the case of the eight tube unit, the plates of the rectifier tubes are connected across the two outside terminals of the B transformer winding so as to provide a high plate voltage and output as required by the eight tube set. Troubles which might be anticipated with the power supply unit are generally as follows: short circuited B supply may be caused by one of the filter condensers becoming shorted or the B plus lead from the filament of the rectifier tube grounded or a choke lead grounded, or in any manner in which the positive side of the rectifier output would become grounded. Generally there is no cause for any of the resistors becoming burned out as their capacity is considerably greater than their operating values. However if in any manner the output of the rectifier should become short circuited directly to any of the resistors, overloading of that resistor will result.

Considerable humming caused by a power unit can generally be traced to one of the following causes: choke coil short circuited, either through short circuiting of the terminals or because the .1 mfd condncer across it is short circuited; open connection to one or more of the filter condensers.

Failure of a particular B voltage in the power unit is generally due to an open circuit in the resistance to which this voltage is supplied. The 180-220 volt B supply is drawn directly from the output of the filter system. The 105 volt B supply is taken from this point through the 4500 ohm resistance. The 45 volt d.c. supply is taken from the 105 volt lead through the 75 ohm resistor.

Crosley Gembox and Showbox Models

BECAUSE of the vast number of Crosley radio receivers in the hands of the public and the consequent large number of service men handling that line, we are glad to include in this department a description of two of the many models made by the Crosley Radio Corp at Cincinnati, Ohio.

Much interesting data is contained in one of the recent issues of the Crosley service manual, which gives general servicing information. For the benefit of our readers, we are making some excerpts from this manual, which should prove highly interesting.

Servicing is a necessary part of every Crosley dealer's and

distributor's work. He must be prepared to service sets promptly and efficiently. Radio sales are built through performance. Performance is guaranteed first by quality products, second by thorough servicing. The quality of servicing rendered is one of the important things which distinguishes a first class radio merchant from a poor one.

A Crosley service man has behind him the basic idea that it is much easier for someone on the ground to straighten out a difficulty than for someone else a thousand miles away to do so. In accordance with this policy, the retail purchaser goes to the authorized dealer from whom he bought his set for information, advice and assistance. The dealer in turn takes his problem to his distributor. When a distributor has problems that he cannot solve, he goes to the factory with them. A special servicing department and a technical information bureau are at his disposal at the factory.

Quick Service Results

By handling service matters according to this plan, every question or problem is insured the most speedy, efficient and satisfactory attention.

Symptoms Help Locate Trouble

There are certain special symptoms when a set is not operating properly that points towards particular causes, and where such symptoms appear considerable time and trouble may be saved by looking for these probable causes first. The more important symptoms that point to the particular causes are:

Set dead. No characteristic tube hiss or background of static heard when set is turned on. Most probable cause is a broken circuit or bad connection. Examine tubes to see if they light. If none light, trace through A battery circuit for broken wires, poor connections, corroded terminals. Test battery. If some tubes fail to light but others light, replace the dead tubes with standard tubes and see if tubes are at fault. Examine socket contacts. If tubes light satisfactory, try replacing them with standard tubes to see if defective tube is the cause of this trouble.

See if aerial and ground leads are connected to set. Examine aerial and ground systems for faults.

See that speaker is properly connected to set. Trace through B battery circuit. Test B battery. Try another speaker.

If no faults are found up to this point, examine the set and if you do not easily find the trouble, take it to the shop and thoroughly test it as outlined in the service sheet for that particular model, examining especially the audio transformers and soldered connections.

(Continued on page 137)

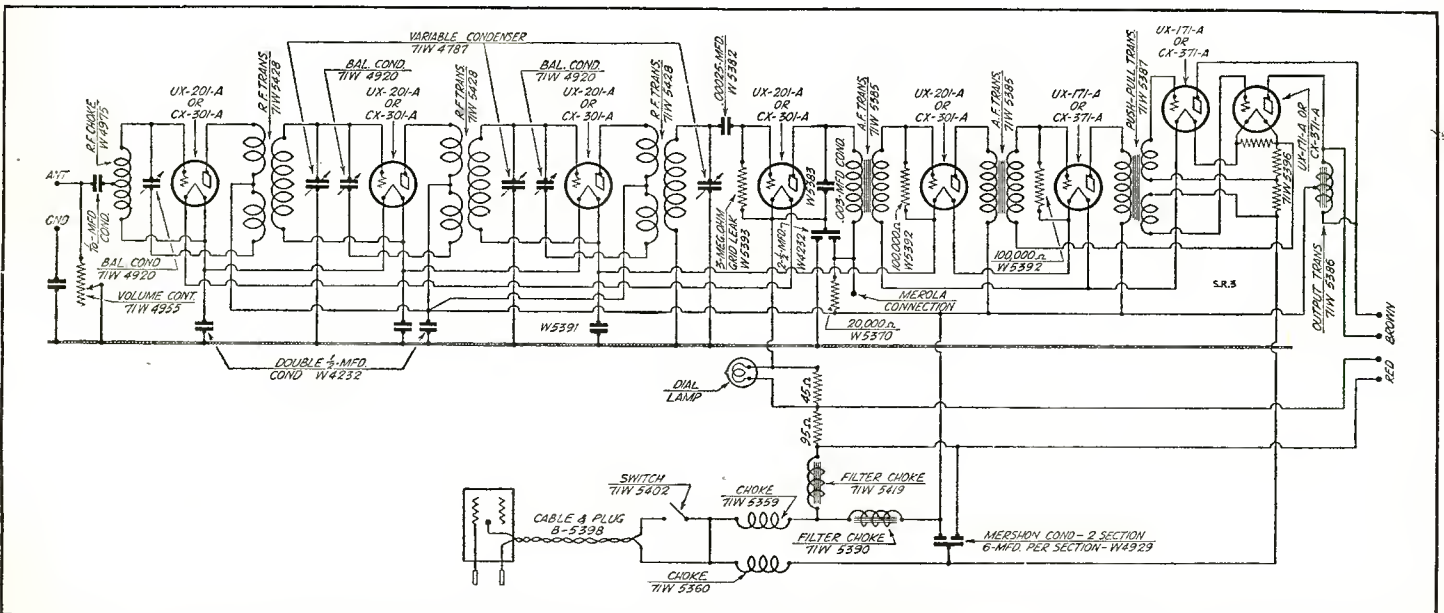
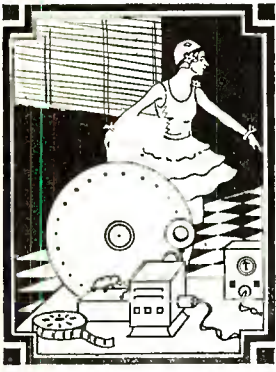

Fig. 7. This schematic diagram shows the electrical constants of the Crosley d. c. Showbox model 705, which is designed for operation from 110 to 120 volt d. c. lighting systems



PRACTICAL TELEVISION



Problems of Television

IN the hopes that our readers will benefit by the clear exposition of the problems of television, we are printing herewith a recent statement by D. E. Replogle of the engineering staff of the Raytheon Mfg. Co.

At a recent meeting of the RMA, that conservative organization went on record as being in favor of "experimental television on experimental wavelengths." It would therefore appear that television is on the eve of making its bow to the American public, in experimental form at least. Nevertheless, undue optimism is entirely out of order, for there are many and serious problems standing in the way of a satisfactory television service at this time. Television, be it noted, is a most complicated branch of engineering, involving an intimate knowledge of radio, electricity, mechanics, gaseous conduction, distortionless amplification, modulation and demodulation, photography, optics, and even a new stage technique. We have much to learn of all these.

No Dearth of Subjects

Some hold that the major problems of television are those of presentation, but with this view we are not wholly in accord. They exist, to be sure, but they are secondary and their solution is in capable hands. Once we have mastered the technique of television transmission, there should be no dearth of subjects. All the world is our stage and we may draw upon it as we will. For the present we must content ourselves with simple shadow-graphs or silhouettes; later, as our knowledge and technical facilities increase, we shall perhaps stage playlets; and ultimately we shall televise speakers and artists before the broadcast microphone, leaving the aural accompaniment entirely at the option of our audiences. After all, the television presentation is a fleeting and instantaneous thing, best suited by long odds to portraying a given subject at a given instant of time. But before we concern ourselves with the pictorial nature of our television images we must first solve the problems attendant upon their propagation and reception.

First Problem Is Detail

Our first major problem, then, is that of detail. And it is a most intricate one, involving dot elements, time coefficients, luminous intensity, accurate synchronization, and, last but not least, available wave channels. We may assume it to be a matter of common knowledge that, because of the width of channel required, television is not possible on standard wavelengths. We are therefore compelled to resort to short-waves or high frequencies, thus automatically assuming the responsibility for the solution of a number of intricate problems. Short waves, it will be noted, are by no means universal in their application. Indeed, a critical analysis of the essentials of a satisfactory television service discloses the fact that we shall have to utilize three separate but simultaneous short-wave channels in meeting the peculiarities and requirements of urban, rural and long-distance reception.

In view of the fact that sound broadcasting is carried on within relatively narrow limits, it may occur to some to ask why we require an excessively wide channel, say 100 kilocycles, for the

propagation of the television image. The reason is that the width of channel determines not only the dimensions of the image itself, but the amount of pictorial detail possible as well. For example, a standard radio channel 10 kilocycles wide would permit us to handle only close-ups and other simple figures and would admit only of the crudest detail. In order that the reader may better appreciate why this is so, we shall at this point briefly analyze the basic television technique as we know it today.

At the transmitting end we simply break up our subject into a number of parallel and overlapping lines by means of the familiar scanning disc—a circular plate with eccentrically placed holes. A photo-electric or light-sensitive cell converts the varying intensity of these lines into varying electrical impulses. These are amplified in the conventional manner and impressed on the outgoing waves of a broadcast transmitter. At the receiving end the signals are further amplified and fed to a neon glow tube or kino lamp—a sensitive device whose luminosity varies with the modulation of the incoming wave. Our problem is to reconvert this luminosity into lines whose gradations are similar to those obtained at the transmitting end. For this purpose we employ a scanning disc which must be revolved in perfect step with the one at the transmitting end. The holes in the disc break up the glowing plate of the kino lamp into a series of lines of varying intensity. At any given instant, however, there is just a single dot of light on the television screen, and its brilliancy or dullness is a function of the modulation of the incoming radio wave at that particular instant. The speed of these successive dots is such that in 1/15th of a second they seem to form lines which in turn unite to weave an entire animated image. It is therefore obvious that television is basically an optical illusion which depends upon the persistence of human vision and upon the slowness of the eye to assimilate ultra-rapid changes of scene.

Pattern of Closely Woven Lines

We thus see that the television image, like the newspaper halftone engraving, is simply a pattern of closely woven, successive lines. The problem therefore resolves itself into questions of how many lines we are using, how much contrast we have between the maximum and minimum intensity, how accurately our lines meet or overlap, and how well we are able to maintain synchronism between two scanning discs. There is, however, a great difference between the halftone engraving and the television image. Crude in detail as the former is, it contains 65 vertical and horizontal rows to the square inch, or a total of 4225 dots. Now, in order to weave an even cruder television image, let us say of 50 line texture or corresponding to 2500 dots to the square inch, we have to transmit its lines in less than 1/16th of a second, or at the stupendous rate of 40,000 dot elements per second.

Referring again to the newspaper halftone, let us call attention to the fact that a minimum image of about 3x5 inches is required for viewing persons and events intelligibly. To achieve this in television practice, even with a 50 line texture, we would have to build up an image 150 lines high and 250 lines wide, a feat which would compel us to transmit the equivalent of 37,500 dot elements in 1/16th of a second. For the present we have accepted the 100

line image as standard technique, inasmuch as it can be transmitted within an 80 kilocycle wave band and permits of a reasonable amount of detail. Even, however, with a 100 kilocycle wave band we may not hope to attain anything like the crystal-clear detail of the present-day motion picture. It must now be obvious that the systems employing 24 line images which may be crowded into a wave band of 4 or 5 kilocycles are wholly inconsistent with a serious television service.

Both Frequencies Essential

In addition to being critical in the matter of screen dimensions, a wide channel, as we have intimated, is essential for proper detail. Both high and low frequencies are absolutely essential. If, for example, we delete the low frequencies, we introduce extraneous shadows and change the tone of the picture. On the other hand, if we light or cut off the high frequencies, we eliminate the sharp lines which are essential to good detail. Further, cutting off the high frequencies will also limit us to slow motion, inasmuch as any rapid action will always appear blurred and indistinct. In general, we might say that television requires a band at least twenty times as wide as that required for the broadcasting of music and speech.

We now come to a consideration of our second major problem, which is that of luminosity. We have accomplished wonders with present neon tubes with their low candlepower, but there is still room for a world of improvement. It seems highly probable that we shall have to develop a lamp which, while retaining the delicate sensitivity of the neon tube, is capable of vastly greater illumination. Further, we must work out more efficient methods for utilizing and conserving the limited amount of light at our disposal. Considerable progress has already been made along these lines by C. Francis Jenkins of Washington, D. C., who has developed a multiple target neon lamp and an ingenious scanning drum which utilizes light-conducting quartz rods. Mr. Jenkins, E. F. W. Alexanderson and others have developed scanning discs with matched lenses which permit us to make a more efficient use of the light source. The matched lens scanning disc requires an exceptionally powerful neon spotlight, but so much progress has already been made by both American and European experimenters in this field that we may consider the problem well on the way of a satisfactory solution at this time.

Synchronization Third Problem

Our third major problem is that of synchronization. If television were to be limited to metropolitan areas where the same alternating current systems are available, it would be a relatively simple matter to keep the two scanning discs in step by means of synchronous motors. Television, however, will doubtless extend to territories in which the same current is not universally available, and we must therefore develop some independent means of achieving our end. Already ingenious speed controls with centrifugal governors making and breaking contacts across speed-control resistances, have been developed. Another ingenious device is a gear arrangement which permits adjustment of the phase relation between a synchronous motor and the position of the disc when it is in motion. Under this arrangement a synchronous motor can be used to drive the transmitting mechanism, and the scanning disc at the receiving end can be controlled so that it can compensate for the difference in phase between transmitter and receiver.

It seems highly probable, however, that the ultimate solution of the problem of synchronization will be found in the use of ingenious breaking devices which will regulate the scanning disc by means of a definite frequency impressed on the television carrier wave along with the signals themselves. Or perhaps there will be a synchronization signal which will be sent out for each revolution of the scanning disc at the transmitting end, and which will tend to start out the scanning disc at the receiving end in step with the transmitting disc at each revolution. These, however, are just possibilities. There are many ways of achieving synchronous operation, as we have outlined.

Use Radio Movies

Then, too, the problem of a nationwide television service is a most serious one, and the production of television receivers on a commercial basis is going to be seriously impaired until some such service is available. The general public can hardly be expected to purchase televisions for home use until it is assured that there are really pictures to tune-in. In this connection it seems highly probable that in the beginning at least we shall make use of the so-called "radio movies." C. Francis Jenkins, Frank Conrad of Westinghouse, and others have already worked out practical systems operating on this principle. The subjects are first recorded on a motion picture film from the negative of which any desired number of prints may be made. One of these is placed in a transmitting device which scans each frame line by line.

The advantages of the film pickup are numerous. The subjects may be filmed under the ideal condition of the motion picture studio and with all the talent desired. The positive prints may be widely distributed and broadcast by any station without special skill or expensive equipment. Thirdly, it is possible to effect a nationwide hookup without the use of wire lines. Lastly, this uniform service over a large part of the country will usher in an era of what we may call "sponsored television." In other words, it will be at once possible to sell television service to large advertisers, much after the manner in which time on the broadcast air is now sold.

Jenkins Broadcast Suggestions

RECENTLY C. Francis Jenkins, with whom our readers are doubtless well acquainted now, made a broadcast talk over WFBM giving some suggestions for receiving the Jenkins radio movies.

Many of our readers who tuned in on that particular station were unable to get the entire broadcast and have asked whether it is available. We are, therefore, glad to give herewith the text of Mr. Jenkins' address:

"At present, and for many months past, we are broadcasting radio movies on 46.7 meters (6420 kilocycles), 48 horizontal lines per picture, beginning at the top, and 15 pictures per second. Our picture signals from our Washington, D. C., laboratory are getting out well, and good radio movies are being reproduced in almost all parts of the country. It is just a matter of proper care and attention to detail, and good results are assured those who desire to participate in these television experiments awaiting the time when we shall have our home televisions or practical television receivers available for the laity.

Motor as Drive

"If you have a 12 inch scanning disc mounted on a motor shaft, as many of you have, and you have another motor available (a 1725 r.p.m. induction or d. c. motor of 1/20th, 1/16th or 1/8th h.p. will do), may I suggest that you utilize the first motor merely as a scanning disc support and the second motor as a driver, in order to secure the best speed control and therefore the steadiest and clearest radio movies. In this connection, cut from the rubber inner tube of an automobile tire a disc about 2½ to 3 inches in diameter, and place this rubber disc between 2 inch diameter washers or flanges on a hub to go on the shaft of the second motor or the driving motor. Now mount this second motor on a board which can slide between guide strips on the platform or table supporting the first motor which carries the scanning disc on its shaft. The driving motor is so located that the rubber disc bears against the back of the scanning disc about three inches from the scanning disc center.

"Leave the current off the first motor and put it into the second motor, leaving the first motor to act only as an idle support for the disc.

"If the television experimenter prefers, it is quite practical to make a suitable support for the scanning disc and eliminate the

(Continued on page 131)

Digest of Science



New Flying Boat for Navy

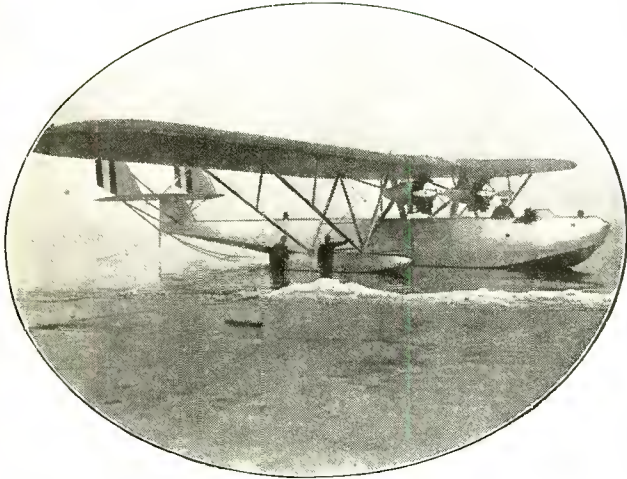

Photo Wide World

This experimental type of flying boat intended for long sea patrol duty is being tested by the Navy at the Anacostia Naval Air Station. The boat designated the XPY-1 was constructed by the Consolidated Aircraft Corp. of Buffalo, N. Y., and is designed to carry 2 pilots, 3 gunners, 2 mechanics and 2 radio men. It has a wing spread of 100 feet and a 60 foot cabin and is equipped with two 430 horsepower Pratt-Whitney engines

Sets Type by Telegraph

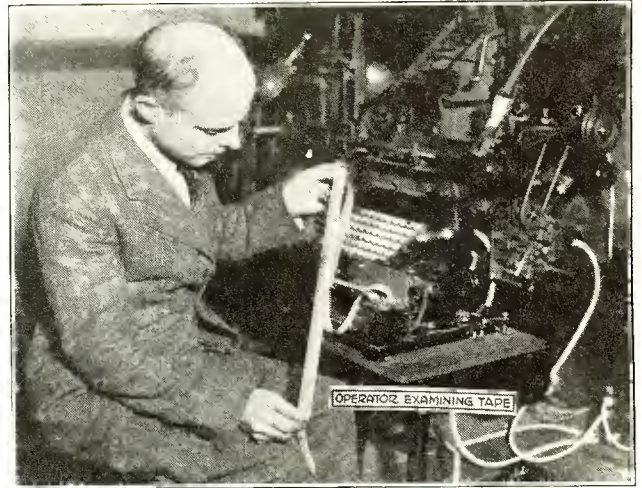

Photo Wide World

Man's efforts to annihilate time and space were crowned with another victory with the recent demonstration of a new device for setting type by telegraph in the offices of the Rochester Times Union. The new device, called the teletypesetter, proved that a single typist might put into automatic and simultaneous operation in a thousand widely scattered newspaper offices a thousand linotype machines which would set type as perfect as if operated by human hands, saving incalculable time and labor. The secret of the new device is an electric typewriter which perforates ticker tape, each round of perforations corresponding to a letter or numeral. The code on the tape is then flashed electrically into a newspaper office, perhaps a thousand miles away, and a tape in the latter office is similarly perforated. The second tape is then put through a device attached to the linotype machine, and electrical impulses translate the code into depressions of the keys on the typesetting machine. Work on the device was begun two years ago by Frank E. Gannett, head of the Gannett newspapers, and Walter W. Morey, of East Orange, N. J. Associated with them were Sterling Morton, president; Howard L. Krum, and Edward Kleinschmidt, vice president; and Dr. L. M. Potts, research engineer of the Morkrum-Kleinschmidt Corp., of Chicago, that will manufacture the machine

Meter Records Tree Growth



Photo Wide World

The electro-ultra-micrometer, the invention of Dr. Georg Goertz of Berlin, which is used to record the growth of different kinds of wood by the definition of the salt concentration in the circulation canals of the trees

Water to be Used in Fuels of Future

Setting the Thames afire is one of the proverbial impossibilities; yet the householders and factory owners of the future will be doing exactly that when they light up the fluid fuel in their furnaces.

This in effect was the prophecy of A. T. Stuart, consulting engineer of Toronto, uttered before the Second International Conference on Bituminous Coal. He based his look ahead on the ever-increasing use of liquid and gas fuels in industrial and domestic power and heating plants, and on the increasingly practicable processes for converting coal and other solid fuels into fluid forms.

The essential of making coal into a liquid or gas fuel without waste is the adding of hydrogen to its carbon. Hydrogen is obtained commercially by breaking up water with electricity. Hence, said Mr. Stuart, "it is not unlikely that more water than coal will be used as raw material and that perhaps half of the energy of future fuel will come from the combustion of hydrogen obtained originally from water."

Loop for Hoisting Subs



Photo Wide World

Loops or "pad eyes" on submarines to which pontoon lifting chains are attached to pull them to surface in case of accident were recently tested at the U. S. Bureau of Standards in Washington. The "pad-eye" device was found to stand a pull of 530,000 pounds, while pontoons exact only a 120,000-pound pull. Photo shows Lt. C. M. Momsen, U. S. N., Bureau of Construction and Repair, examining the links, and T. J. Briggs, of the Bureau of Standards, Chief of the Division of Mechanics, on the right

sented recently for the first time, by Prof. Edward S. C. Smith of Union College. Prof. Smith has discovered abundant fossils of an organism known as *Oldhamia occidentis*, which seems to have been a kind of seaweed, in a thick series of folded slates and sandstones along the banks of the east branch of the Penobscot river.

Artificial Crag for Goats



Photo Wide World

So that the nimble-footed mountain goats at the Balboa Park Zoo, San Diego, Calif., may feel right at home, an artificial crag has been built in the center of their inclosure. It is quite popular, as may be seen by the photograph

First Steam-Driven Dirigible

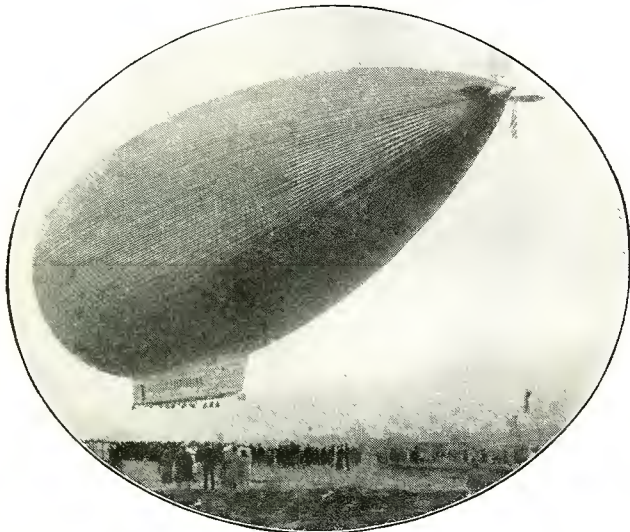

Photo Wide World

The "City of Glendale," world's first all-metal steam-driven dirigible, emerged from its hangar and was floated, without power, for the first time recently at Glendale, Calif. After taking the big all-metal bag off the ground for buoyancy tests, Capt. T. B. Slate, its designer and builder, had his crew return it to the hangar to complete the installation of the boilers, turbine and "blower" propeller in the nose of the ship

Talks with Byrd



Photo Wide World

Edward Dana Redington, 16 year old student at McKinley Technical High School, Washington, D. C., photographed at his radio with which he has exchanged messages with Commander Byrd at the South Pole. Redington, one of the most enthusiastic radio students at the school and secretary of the Tech Radio Club, designed and built his station at a cost of approximately \$100.00. His call letter is W3KR

Ancient Seaweed Found in Rocks of Maine

Back in Cambrian geological time, so long ago that geologists refuse to estimate its age even in millions of years, the sea stood where the Penobscot river now finds its way across the rocks of Maine. The invasions of this ancient Cambrian sea are known from other parts of this continent, but the evidence for the ancient "wetness" of the oldest of dry states was pre-

Hot Wire Measures Wind Speed

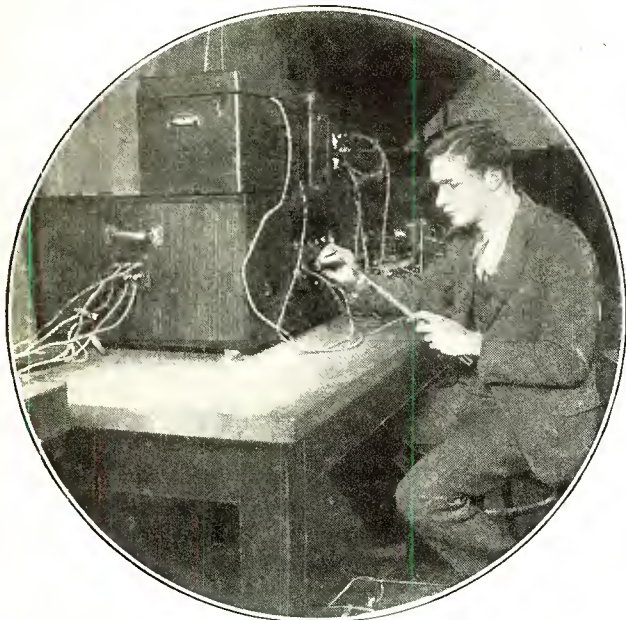

Photo Wide World

A hot wire is now being used by the Bureau of Standards to measure wind velocities. The measurements are made with an electrically heated wire about one-fifth of the diameter of a human hair and a five-tube amplifier, the winds being produced in tunnels. Very uniform and steady air currents, so that the conditions of flow around an airplane may be accurately reproduced, are sought. Since air tends to flow in ripples and waves, such disturbances often cause difficulty in obtaining accurate results. Photo shows Arnold Kuethe, Aerodynamical secretary at the Bureau, operating the instrument

that in the western group, or Greater Antilles, they were apparently pedestrians, crossing from the South American mainland over a land connection long since sunk into the sea. Along the Greater Antilles to the east, however, they give evidence of having traveled by air, the lines of distribution lying approximately in the direction of the most frequent hurricanes.

Fuelling on the Fly



Photo Wide World

The tri-motored army plane "Question Mark" takes on fuel while flying at a rate of 80 miles an hour in its 151-hour endurance limit flight

Hot Coffee for Smoke Eaters



Photo Wide World

"Coffee Service Car," manned by women of Pasadena, California, for the comfort of the city's firefighters, is given public demonstration. The new kitchen on wheels is driven close to the scene of large fires, where the smoke-eaters are oftentimes forced to work long hours without refreshment, and hot coffee and food served them by a crew of efficient women cooks. The car has its own hot plate, table, sink, ice box, five-gallon coffee urn, dishes, fresh water and food supplies. In addition it carries a first aid compartment.

1400-Pound Meteorite Exhibited

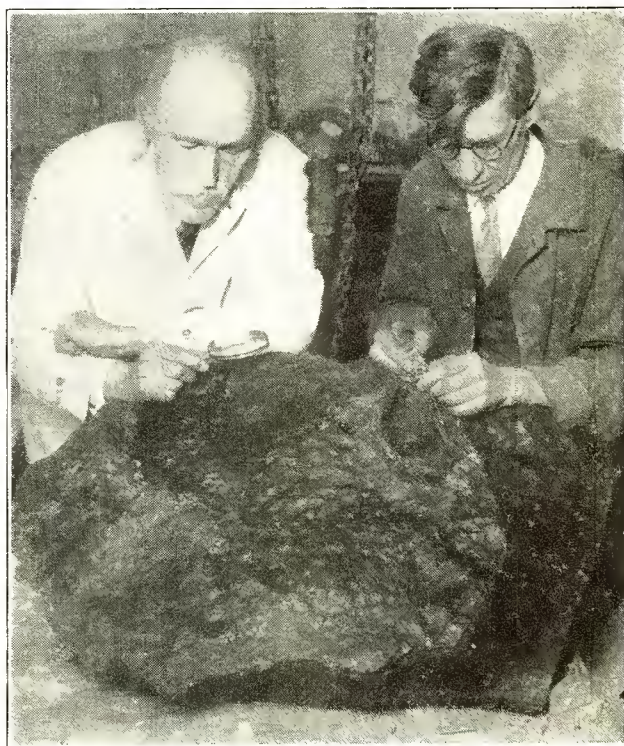

Photo Wide World

A meteorite weighing 1400 pounds, found in the vicinity of Goldstone, Queensland, Australia, is being prepared for exhibition purposes at the Field Museum of Natural History. The meteorite was discovered by kangaroo hunters on the edge of a gully. It contains 93 per cent iron and 6 per cent nickel. In addition it contains small quantities of platinum, a form of carbon-like prahite and some sulphite. Prof. J. B. Abbott, chief preparator in the museum's department of geology, is preparing the meteorite and casting it for permanency under the direction of Dr. Oliver C. Farrington, head curator of geology

Tropical Spiders Ride Hurricanes

The spiders of some of the islands of the West Indies have been long-distance aviators for many ages, according to Prof. Alexander Petrunkevitch of Yale University. And hurricanes have helped their flights instead of hindering them.

Prof. Petrunkevitch has been making a study of the distribution of spider species in the tropical American islands, and finds

Oil from Chinese Trees



Photo Wide World

T. Morris Carnegie, nephew of the late steel magnate, is now carrying on the unique experiment on his Fernandina, Florida, estate on the production of oil from Chinese tung trees. Mr. Carnegie estimates that mature trees will produce from 400 to 1800 pounds of oil to the acre, and if the experiment is successful he plans to develop the trees along commercial lines. Photo shows T. Morris Carnegie and a worker on his estate with some of the Chinese tung tree nuts.

Float Span Into Position



Photo Wide World

What is claimed to be one of the greatest engineering feats in modern times is now in progress in France. A mile-long bridge is being constructed across the River Elorn, linking the famous naval town of Brest with Plougastel. Three enormous spans, each measuring about 180 meters in length, will form part of the bridge. This photo shows one of the great spans being floated into position

Mows Neptune's Lawn

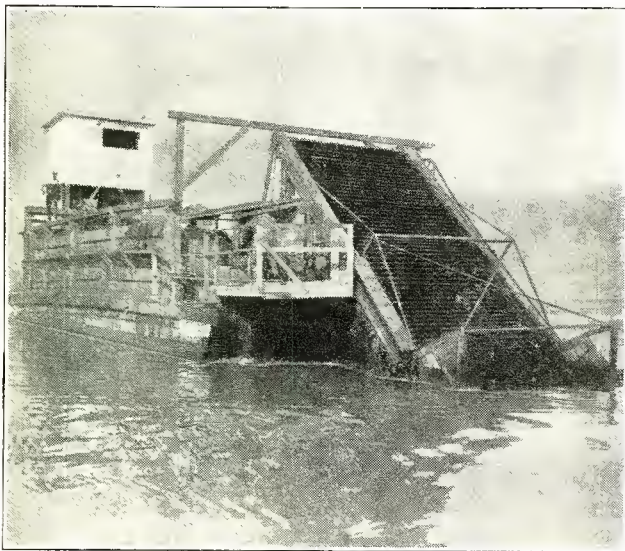

Photo Wide World

This novel craft, named the "Marine Lawn-mower," scoops up kelp from the bottom of Los Angeles harbor with the large washboard-like device with blades that travel on an endless chain, that is lowered over the prow of the vessel. The kelp brought up is cut up, ground and dried, and then sold as food for livestock

Carve Huge Obelisk for Mussolini



Photo Wide World

The largest block of marble in the world, which weighs over 50 tons, slides down the mountain at Carrara on its way to Rome, where it will be carved as an obelisk to be placed on front of the Mussolini stadium.

Drives Iodine Through Tooth Root



Photo Wide World

N. F. Clayton, an Atlanta, Georgia, electrical engineer, with the machine he has developed for driving iodine down through the root of an abscessed tooth, into the abscess. The effect is to destroy the abscess and save the tooth without pulling

by M. K. Campbell of the U. S. Geological Survey. Mr. Campbell has made a study of geologically recent gravel deposits on the old river terraces on the Potomac, Susquehanna and Schuylkill rivers, and has found them bent upwards at three different places. The arching is not great, but it is sufficient to indicate upfoldings in the deeper layers of the earth, taking place long after the mountain-building movements that gave rise to the Appalachian system.

Dam Interferes with Salmon Migration

Capturing an entire salmon run and lifting the fish bodily over a dam which now obstructs their route toward the ancestral spawning grounds, is the radical step advocated by Prof. Henry B. Ward of the University of Illinois.

Prof. Ward has for several years been making a study of the effects of a power dam across the Baker River, Oregon, on the annual run of the salmon. He found that the migrating fish tend to seek the coldest water, and since at this dam the coldest water issues from the power-house tailrace, the salmon exhaust themselves in useless attempts to swim up this torrent.

The construction of the dam has created a deep, cold lake which has captured some of the young salmon migrating downstream towards the ocean, and thus has produced a race that is physiologically landlocked. This race, however, is small and of no commercial value.

Masks to Help Cure Asthma

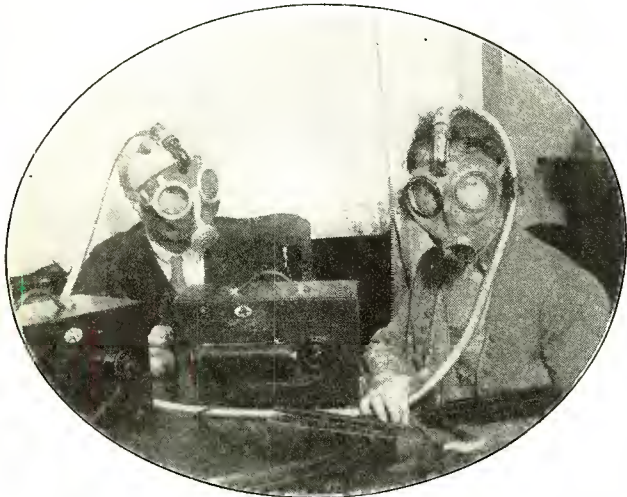

Photo Wide World

Drs. Fraenkel and Levy of Berlin, together with engineers of the Auer Light Co., have invented a mask to eliminate the elements in the air that irritate the air passages of asthmatic patients. The photograph shows the mask being tested.

Tiny Furnace Develops Great Heat



Photo Wide World

Unique exhibits are prepared for the Western Metal Congress to be held in Los Angeles in the very near future. The convention, at which fourteen national associations will be represented, will deal with new methods of making, working, treating, welding and use of metals. Here's the smallest furnace to be exhibited at the coming Metal Congress. Despite its diminutive size, it develops a heat of 1200 degrees Fahrenheit. Miss Florence Lorrell is demonstrating its effect on different metal properties contained in tiny crucibles

Recently "Sprouted" Hills Found East of Appalachians

Are new mountains beginning to grow along the Atlantic seaboard of America?

At least slight indications that such may be the case were called to the attention of the National Academy of Sciences

WITH THE ACCESSORY & PARTS MANUFACTURERS

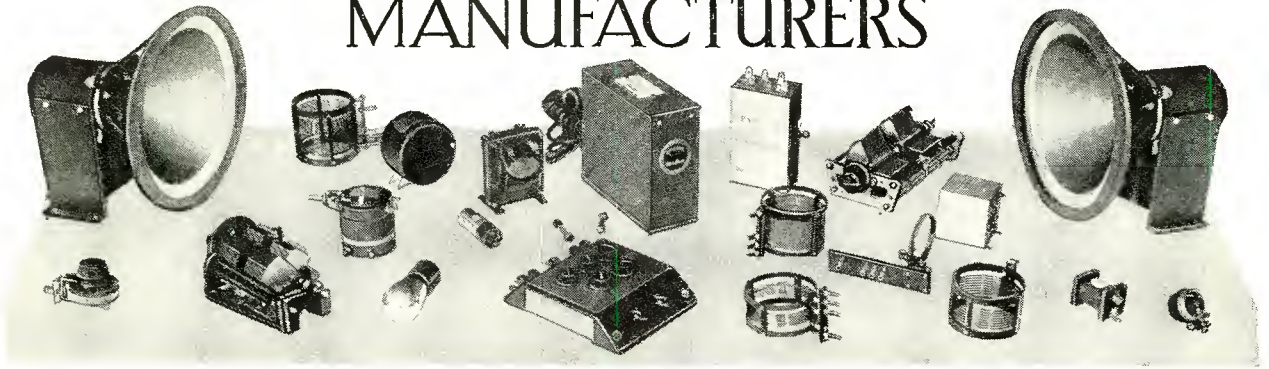

Ferranti Is Now Marketing a Line of Power Amplifier Units

A RECENT announcement has been made by Ferranti, Inc., 130 West 42nd Street, New York City, of a new line of Ferranti push-pull power amplifiers, which will be produced in three types, including the 171, 250 and the new RCA 50 volt bias tube in two stages. All amplifiers are designed to get full rated power out of the tube without distortion.

One of the amplifiers is illustrated on this page, so the reader may have an idea as to the type of production. All of the ampli-

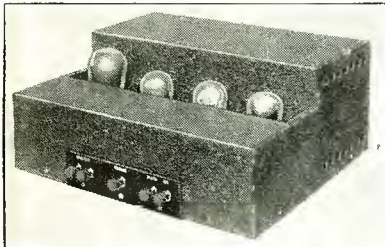

This is the new Ferranti push-pull power amplifier recently announced for the market. It is described on this page

fiers are similar in appearance and are made under license from the RCA.

The amplifier which was tested in this laboratory was designed for the operation of dynamic cones of the Magnavox and Wright-DeCoster type. In order to secure the best results, it is necessary to remove the output transformer in the speaker and connect the voice coil of the speaker direct to the speaker connections on the amplifier, which is equipped with a double secondary transformer with a ratio of 25 and 50 to 1. The two outside speaker posts give a ratio of 25 to 1, and the center and one outside post give a ratio of 50 to 1. If it is desired to operate two speakers, one may be connected across each line of the secondary and for four speakers the same connection is used with two speakers in parallel.

Resistance capacity filters are used freely in the plate and grid lines of all types to prevent oscillation and feed back, resulting in sharp, clear response. All voltages are fixed at the correct value and no adjusting is necessary. A natural circulation of air is obtained through the location of the tubes in an exposed position and the ventilation of the housing.

The 171 type with a single dynamic speaker will give more volume than necessary for a large room and is especially recommended for home use. The new 50 volt bias tube amplifier is recommended for those who desire a powerful amplifier capable

of operating two dynamic speakers at full volume and suitable for furnishing dance music for the home or small ball room. The 250 type is recommended where heavy duty is required and it will operate four dynamic speakers, producing sufficient volume for a large auditorium. The larger amplifiers are admirably adapted for the distribution of broadcast reception to several rooms in residences, public buildings and hotels.

Aero Has New S. W. Converter to Fit All Radio Sets

A NEW short-wave converter is now on the market and already in the hands of leading jobbers and dealers that fits all makes of present radio receivers, both a.c. and d.c. This new product, the Aero-Call, is a complete factory-built short-wave radio adapter set that plugs right into the detector socket of any make of radio and transforms the radio set into a modern short-wave receiver.

This new device now makes it both easy and practical to utilize one's radio set for short-wave reception, as the Aero-Call utilizes the power and hook-up of the regular receiver, and all that is required is to pull the detector tube out of the set and plug in the Aero-Call socket whenever short-wave reception is desired.

Being equipped with a special filter control, the annoyance of motor-boating, prevalent in some devices now on the market, is entirely eliminated.

The whole unit is neat and compact, being completely shielded and housed in an artistic browntone cabinet, with everything out of sight, making a suitable companion for even the most imposing and artistic radio or phonograph cabinet or set.

It is a well-known fact that in short-wave reception, distant stations using low waves, in such countries as England, Germany,

Aero's new short wave converter is completely shielded and fits any radio set. It is available for either d.c. or a.c.

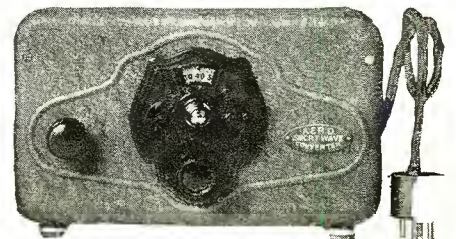

Holland, Australia, Java and many far-off countries, are received daily by amateurs and "hams" in our own country. Code as well as excellent musical programs are broadcast regularly over short-wave here and abroad. This new and unique side of radio is now being made available to every radio set owner by the use of the Aero-Call short wave converter.

The Aero-Call, measuring only $9 \times 5\frac{1}{2} \times 2\frac{1}{2}$ inches, is made in both a.c. and d.c. models, each of which retails for \$25, including three types of plug-in coils and everything necessary to receive short-wave programs, and is manufactured by the Aero Products, Inc., 4611 East Ravenswood Avenue, Chicago, a long-established manufacturer of professional short-wave apparatus and the well-known Aero Coils.

Radio Products of Dayton Has S. W. Adapter and Tube Checker

TWO devices, one especially suited for the professional set builder or service and repair man, and the other for the broadcast enthusiasts who wish to listen in on the short waves, have recently been announced by the Radio Products Co. of Dayton, Ohio.

One of the products illustrated herewith is the Flewelling short wave adapter, by means of which the listener may pick up broad-

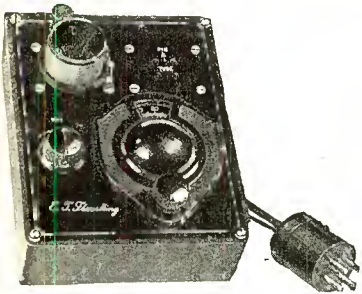

Here is shown the Flewelling short wave adapter, one of the items marketed by the Radio Products Co. of Dayton, Ohio

cast programs from abroad as well as from the United States. The adapter is built under the personal supervision of E. T. Flewelling, well known as one of the pioneers in radio. No additional tubes, batteries or wiring are required, as the adapter is a complete unit and plugs into any radio set.

Of especial interest at this time is the Flewelling a.c. tube checker, which tests standard a.c. and d.c. receiving tubes direct from the light socket, no batteries or other connections being required. There are no rheostats or other adjustments to make. The condition of the tube is clearly indicated by referring to a table, which is engraved on the panel of the tube checker. It is equipped with a standard milliammeter of the D'Arsonval movement and is housed in a mounted bakelite box with a neat leather carrying strap. Brackets for mounting on the wall or table are included. It has an attractive verichromed panel. Highest quality of materials and construction throughout. The size overall is $7 \times 5\frac{1}{2} \times 2\frac{1}{2}$ inches. Shipping weight is $3\frac{1}{2}$ pounds.

Polymet Enters Coil Winding Field by Purchase of Coilton Electric Mfg. Co.

THE Polymet Manufacturing Corporation, one of the country's largest and best known makers of electric set essentials, announces its entrance into the coil field with the acquisition of the Coilton Electric Manufacturing Company of Easton, Pa.

The absorption, under the Polymet name of this large and well-known coil plant, will undoubtedly prove of great interest to the radio, speaker and other coil-using industries. It associates a name, long synonymous in radio with quality, service and dependability with the coil industry, an industry in which demand has far outstripped available supply during past months. Polymet, through this acquisition, will be even more closely tied to manufacturers and users of radio parts by adding power transformer coils, audio transformer coils, transformers, coils for dynam-

ics and power packs to its present line of filter blocks, condensers and resistances.

The Coilton Electric Manufacturing Company's windings have been established for over eleven years, and have established a reputation for quality which has warranted their incorporation in leading radio receivers, dynamic speakers and many other coil-using products. Under Polymet direction it is planned to increase the size of the plant by 25,000 to 30,000 square feet of floor space; fifty to a hundred new multiple-winding machines are to be added to the present equipment, and the factory force is to be augmented in proportion, so that production may be kept in line with orders.

"Sales of coil windings continue in large volume," said Nathaniel Greene, vice-president of the Polymet Manufacturing Corporation, "and radio receiver manufacturers are working at top speed with the close of 1928. Indications are that the same pace will be maintained in 1929 due to the continued heavy demand for electric sets and dynamics."

True Tone Radio Sales Has a Si-len-ser to Cure Line Noises

SINCE the electric receiver has become popular, every large radio factory and engineers in all parts of the country have been trying to perfect a device that would eliminate a.c. and d.c. line noises which come from power house generators and motors, or outside electrical interference, which greatly interfere with the proper reception of radio broadcast.

Such a device has been perfected and is manufactured by The Truetone Radio Sales Co., 114 Worth Street, New York City. A special filter block was designed which uses specially designed coils. It is in these coils that the success of the Si-len-ser depends. The filter block uses two condensers also which are grounded at the common lead. The device, or Si-len-ser, as it is known commercially, is about five inches high and weighs about $4\frac{1}{2}$ pounds, the wire weighing the most part of this.

It is claimed that in addition to eliminating outside electrical interference not due to aerial pick-up, the Si-len-ser will kill all line noises, hum, heterodyning due to electric leaks or stop interference from the ordinary household appliances which operate on the house current.

As with the radio set, the Si-len-ser is easily attached to the electric light socket and the plug of the receiver, or the plug of the household apparatus placed in the device.

Custom Built Portable Weighing 30 lbs. Made by Alvon

IN keeping with the custom built trend, it is now possible to secure custom built portable radio sets, according to a recent announcement by the Alvon Radio Laboratories, 716 West Madison Street, Chicago.

The custom built job referred to is shown in the illustration accompanying this text. It is $13\frac{3}{4}$ inches high, $14\frac{1}{4}$ inches wide and $8\frac{7}{8}$ inches deep. Inside of the rear of the receiver are three 45 volt batteries, three dry cells, one $22\frac{1}{2}$ volt C battery and one $4\frac{1}{2}$ volt C battery. In the front of the receiver are located the two tuning dials, a meter, two refining controls and the speaker. The loop is located in the cover at the left and swings on its

(Continued on page 136)

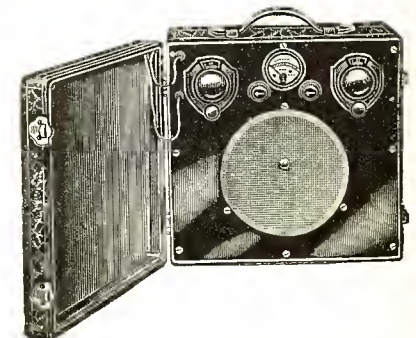

A fully equipped portable that only weighs 30 pounds is shown here. It is a custom built portable made by the Alvon Radio Laboratories, Chicago

SM

Australia to New York— Verified Reception

done—of course—with an S-M Receiver!

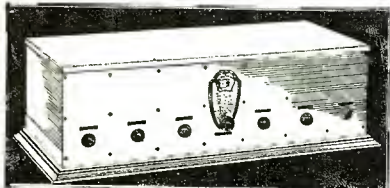

The great Sargent-Rayment 710—aply termed "The Boss of the Air." Everything the most fastidious listener might want—an ultra-sensitive and knife-edge tuning set, which can, nevertheless, be operated when desired as a real one-dial set—with tone quality unsurpassed even in sets not designed for unusual selectivity. All this at \$130.00 for the KIT, or \$175.00 WIRED—both prices including cabinet!

Giant Voiced—Yet Pure Toned

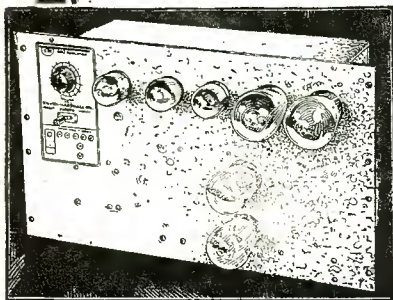

S-M 690 Amplifier: built on black crackle-finished heavy aluminum panel 12x21 inches. Uses seven tubes: 1st stage, one '27; 2nd stage, two '26's in push-pull; 3rd stage, two '50's in push-pull; two '81 rectifiers. Clough audio system used throughout.

List price, assembled complete less tubes, \$245.

AUSTRALIA to New York City on A 353 meters! Direct verification from Station 2BL in Sydney, New South Wales, to a listener by the Hudson—one of the many thousands who have successfully employed the S-M Sargent-Rayment Seven to break through congested local interference.

We congratulate Mr. Parzelt on this feat of reception, and are happy to be able to supply, to all who desire it, a receiver of such caliber.

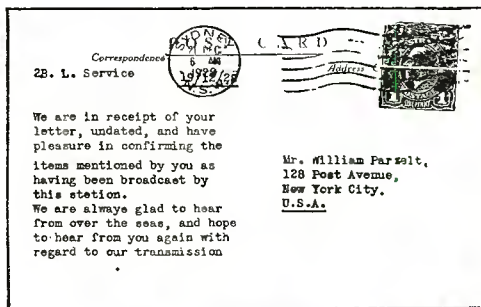

Correspondence
2B. L. Service

We are in receipt of your letter, undated, and have pleasure in confirming the items mentioned by you as having been broadcast by this station. We are always glad to hear from over the seas, and hope to hear from you again with regard to our transmission.

Mr. William Parzelt,
128 Post Avenue,
New York City,
U.S.A.

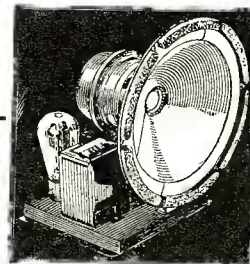

Now a Speaker Made as Good as S-M Amplifiers

The S-M Dynamic Speaker, now announced for the first time, establishes still more firmly the superiority of S-M sound amplifying equipment—a speaker supreme in its ability to handle without distortion an amazingly large amount of power. Has the new S-M 229 output transformer built in, with output taps providing proper impedance matching for use with 171, 250, or the new intermediate power tubes, singly or in push-pull. Two types: S-M 850, for 110 volts A. C. (using '80 rectifier tube) \$58.50. S-M 851, for 110 volts D. C. \$48.50.

NEVER before has such an amplifier as the 690 been available to the set-builder and service man! It brings within his control installation jobs in theatres, auditoriums, and for all public occasions. The public, thoroughly awakened by the talking-movie, is demanding life-like, high-power speech and music—no more "straining the ears."

Find out today about the remarkable things that can be done with an amplifier delivering such tremendous power output as 15,000 milliwatts — from phonograph, microphone, or radio-detector input—with three-point switch on the panel, as well as a knob giving smooth fading control, whatever input is being taken.

Get the new S-M catalog—and begin today to look about you for the opportunities that exist everywhere to make good money by installing S-M amplifiers.

Silver-Marshall, Inc.

836 W. Jackson Blvd., Chicago, U. S. A.

... Please send me, free, the complete S-M Catalog; also sample copy of The Radiobuilder.

For enclosed... in stamps, send me the following:

- ... 50c Next 12 issues of The Radiobuilder
- ... \$1.00 Next 25 issues of The Radiobuilder
- S-M DATA SHEETS as follows, at 2c each:
- ... No. 1. 670B, 670ABC Reservoir Power Units
- ... No. 2. 685 Public Address Unitac
- ... No. 3. 730, 731, 732 "Round-the-World" Short Wave Sets
- ... No. 4. 223, 225, 226, 256, 251 Audio Transformers
- ... No. 5. 720 Screen Grid Six Receiver
- ... No. 6. 740 "Coast-to-Coast" Screen Grid Four
- ... No. 7. 675ABC High-Voltage Power Supply and 676 Dynamic Speaker Amplifier
- ... No. 8. Sargent-Rayment Seven
- ... No. 9. 678PD Phonograph Amplifier
- ... No. 10. 720AC All-Electric Screen-Grid Six.

.....Name

.....Address

The Radiobuilder, a monthly publication telling the very latest developments of the S-M laboratories, is too valuable for any set-builder to be without. No. 9 (Jan. 1929) gave full particulars about the new apparatus described above, long before it was available in any other form. Send the coupon for free sample copy, or to enter your subscription if you want it regularly.

If you build professionally, but do not have as yet the S-M Authorized Service Station appointment, be sure to ask about it.

SILVER-MARSHALL, Inc.
836 West Jackson Blvd., Chicago, U. S. A.

SM

Be the FIRST to build the FIRST

set designed around 1930 tubes

the long-awaited **S-M All-Electric Screen-Grid Six**

➔ Get It FIRST from W. C. Braun Co. ◀

HERE is your chance—build the S-M 720AC All-Electric Screen-Grid Six, and be the first in your neighborhood to own a real 1930 receiver—a set actually designed around tubes of a type utterly new—not found at all in 1929 sets! Just as the 222 screen-grid tube set a new standard of reception in 1928—so the new RCA-Cunningham A.C. screen-grid tube—an even better r.f. amplifier than the '22—will be the central feature of fine receivers for 1930.

And in the audio end as well—the new medium-voltage, super-power output tube will give for the first time all the undistorted volume which could be desired for home use without high voltage wiring.

The receiver in which these revolutionary features are first offered is naturally enough—a Silver-Marshall design—one in which every feature of the record-breaking 720 (D. C.) Screen-Grid has been embodied and still further improved.

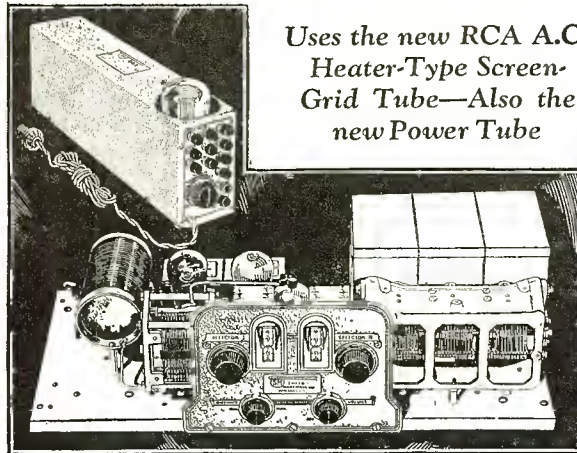

Uses the new RCA A.C. Heater-Type Screen-Grid Tube—Also the new Power Tube

Build the 720AC and See How Next Year's Best Receivers Will Tune and Sound!

THE S-M 720AC Screen-Grid Six, used with the new S-M 669 power supply, is a complete all-electric receiver designed especially to bring out the extreme possibilities of the new RCA screen-grid tube. Three of these tubes are used in the r. f. stages, one 227 tube as detector, another as first stage audio amplifier, and one output tube of the new super-power intermediate-voltage type. Price (less tubes) complete KIT without cabinet \$78.50; S-M 700 cabinet, extra \$9.25. Receiver WIRED complete in the beautiful 700 two-tone shielding cabinet, less tubes and power unit, \$108.00.

Promptness on These, Too—from W. C. Braun Co.

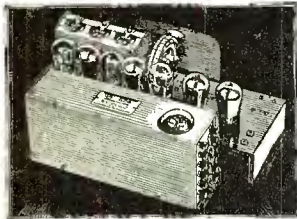

The New S-M 750 All-Electric 7-Tube Receiver

Employs four '26 and one '27 tubes, and two '71's in push-pull with the famous S-M Clough-system transformers. Special power unit within cabinet, using '80 tube. Control by single illuminated dial—full light-socket-operation (for 105-120 volts 50-60 cycles only). A set whose performance rivals any ever designed for the popular-priced A.C. tubes. Built complete in S-M 700 cabinet, \$99. Wired chassis, without cabinet, \$89.

S-M Screen-Grid Kits—Breaking All Records for Performance and Sales

S-M receiver kits are available from W. C. Braun Company in all types to suit all requirements—each one an absolute leader in its class.

The Sargent Raymont Seven—world-circling record-breaker—a single control set (with five individual verniers for DX peaking) using four screen-grid tubes, comes complete with handsome aluminum shielding cabinet: KIT \$130, or custom-built complete \$175.

The original 720 Screen-Grid Six—the famous set with which Japanese, Cuban, and Mexican stations are being heard all over the U. S.—has set up an entirely new standard of moderate-price radio value. Six of these 720's are used aboard the U. S. battleship California, flagship of the Pacific fleet, to cut through the ship's powerful transmitters. Tone quality unbeatable, due to the S-M Clough audio system. KIT complete with chassis and antique brass escutcheon, \$72.50; 700 cabinet extra \$9.25. Custom-built complete in cabinet, \$102.

Yes—we have in stock, and strongly recommend as a real "buy"

The New S-M Dynamic Speaker

(See illustration on opposite page)

850 (A.C.) ... \$58.50
851 (D.C.) ... 48.50

OFFICIAL WHOLESALE DISTRIBUTORS FOR S-M PRODUCTS

As official wholesale distributors for the products of the Silver-Marshall laboratories, W. C. Braun Co., Wholesale Radio Headquarters, offers you this big line of radio merchandise with the assurance that your orders will be filled on the very day they are received. Our plant is located very close to the Silver-Marshall factories and we can give you service on your orders impossible to secure anywhere else. Order your favorite S-M parts, kits and supplies here. You'll save time and money.

In addition to the complete Silver-Marshall line, we offer you a complete line of everything in the radio field—sets, radio furniture, tubes, power units, portable receivers, dynamic and other speakers, parts and kits for all popular circuits advertised in the leading radio publications, short wave and television

supplies, short wave transmitters, radiophones, public address systems, novelties, etc.

Special departments include auto tires and tubes, auto accessories, electrical goods, lighting fixtures, wiring material, household appliances, stoves, vacuum cleaners, washing machines, camping equipment, sporting goods, golf and baseball supplies, outing clothing and thousands of everyday necessities.

Our centralized location insures fast service to customers in all parts of the country.

Thousands of choice bargains are shown in the big 1929 Braun Catalog. If you haven't a copy, send for it at once. It is free—mail the handy coupon now.

W. C. BRAUN COMPANY

Pioneers in Radio

596-G W. Randolph St.

CHICAGO ILLINOIS

W. C. BRAUN CO.,

596-G W. Randolph St., Chicago

Dear Sirs: I am not receiving the W. C. Braun Co. Catalog regularly. Please put my name on your mailing list of set-builders and dealers, giving me the prices and information on S-M parts and other merchandise including the new 720AC. My letterhead is attached.

Name.....

St. & No.....

City.....State.....

SM

**It Does
the Job
in the Navy!**

UNITED STATES FLEET
BATTLE FLEET
U. S. CALIFORNIA FLAGSHIP
6 December, 1929

Statement:

There are now in use on board the USS CALIFORNIA six S-M quality Silver-Marshall 720 screen-grid six tube broadcast receivers. These receivers are giving faithful and satisfactory performance at all times, regardless of the short distance of the powerful ships transmitters.

In direct comparative tests the Silver-Marshall other well known types of ready made receivers. The selectivity of these receivers is unconditionally adequate for the most exact radio condition as experienced in battleships and radio centers. The volume and quality is satisfactory for operation of dynamic loud speakers and give programs finer than heard elsewhere.

All officers' messes and crew divisions use these receivers. Today, I have received an order for one more set and will have more orders very shortly.

Yours very truly,
Thos. A. Marshall
Assistant to Fleet Radio Officer

(Note: Mr. Marshall is not connected in any way with Silver-Marshall, Inc.)

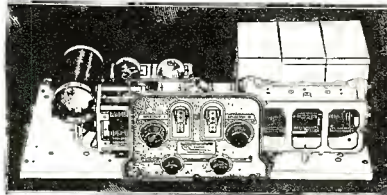

Why not have, beautifully mounted in your own home, the same radio receiver which gives such hearty enjoyment to the officers and men of the flagship California? You can get it, QUICKLY, from Western Radio. And when you hear it you will not be surprised at the enthusiasm of Uncle Sam's sailors—for its three screen-grid tubes, and its three perfectly shielded stages, with S-M quality coils and transformers throughout, assure to the user a standard of reception never before attained at anywhere near the price. The complete KIT is priced at only \$72.50, with a beautiful two-tone metal shielding cabinet at \$9.25 additional. Completely assembled in this 700 cabinet, \$102.

**Built the New 720AC All-Electric S-G Six—
first set designed for the new 1930 tubes!**

Get it, "hot off the griddle," from Western Radio: KIT, less cabinet, \$78. WIRED complete, \$107.50. Western Radio carries the largest and fastest moving stock of SILVER-MARSHALL parts in Chicago, and can give immediate delivery on the new 690 and 679 amplifiers, new dynamic speakers, as well as all other S-M parts, kits and accessories. Send the coupon and get our catalog. **MAXIMUM DISCOUNTS TO DEALERS.**

Western Radio Mfg. Co.,
128 West Lake Street,
Dept. SM-3,
Chicago, Illinois.

Please send at once your new FREE catalog listing S-M parts and kits as well as many other highest-quality radio products.

Name.....
Address.....
Town and State.....

Mail this Coupon — Get our
FREE Wholesale Catalog

WESTERN RADIO MFG. CO.
THE BIG, FRIENDLY RADIO HOUSE
128 W. Lake St. Chicago, Illinois

SM

**If You
Didn't Think
Four Tubes
Would Do This—**

Then it would interest you to see the list of forty-nine stations heard by William Snellboker at his location within five blocks of Station WRAX in the city of Philadelphia—using an S-M 740AC Coast-to-Coast Four. Starting in with the stations that one would expect to get in such a spot with the average six or seven-tube set, Mr. Snellboker then reached out and brought in such stations as KYW, Chicago, Ill.; WGBF, Evansville, Ind.; WFLA, Clearwater, Fla.; WGN, Chicago, Ill.; WHAS, Louisville, Ky.; WLW, Cincinnati, Ohio; WMAQ, Chicago, Ill.; WOC, Davenport, Iowa; WSAI, Mason, Ohio; KWKH, Kennonwood, La.; CKAC, Toronto, Canada.

**740
for
D. C.
Tubes**

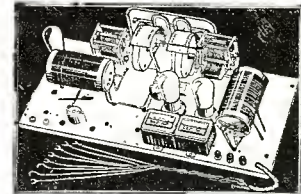

**740AC
for
A. C.
Tubes**

This receiver, available for either D.C. or A.C. tubes, uses the 4-tube r.f. amplifier, regenerative detector, and two-stage audio amplifier circuit—for many listeners the time-tested standard of receiver comparison. The screen-grid r.f. amplifier stage, together with the finest coils ever utilized in this circuit, provide 10 to 20 kc. selectivity.

With the ease and simplicity of building, and performance like that described above, we declare it as our firm conviction that more radio value cannot be had listed around \$50.

S-M 740, for D.C. tubes, lists at \$51.00 for factory-packed KIT; S-M 700 cabinet (same as used on the 720 Six) is \$9.25 extra. S-M 740 WIRED complete in cabinet, \$75.00.

S-M 740AC, for A.C. tubes throughout, lists at \$53.00 for complete KIT less cabinet, or \$78.00 WIRED in cabinet.

OUR NET PRICES TO SETBUILDERS ARE THE LOWEST

We carry an enormous stock including all the big new S-M products—the wonderful 720AC for "next year's tubes," the 690 and 679 amplifiers, and the new dynamic speakers. Our enormous buying power gives you rock-bottom wholesale prices; send the coupon for our new 1929 catalog, jammed with big bargains. Twenty-four hour service guaranteed on mail orders.

**CHICAGO
SALVAGE
STOCK
STORE**

Wholesale
Department CB3
509 S. State St.
Chicago, Illinois



CHICAGO SALVAGE STOCK STORE, Dept. CB3
509 S. State Street,
Chicago, Illinois.

Please send me free of charge your new 1929 catalog listing S-M and other standard and nationally famous sets and parts.

Name.....
Address.....
Town and State.....

SM

**Travel
Round-the-World
on an S-M 730
Short-Wave Set**

The S-M "Round-the-World" receiver uses every modern device, from super-accurate condensers to perfect aluminum shielding, to get the last word in short-wave reception. Results: listeners all over the world are proving that the set is well named—as for example Orlo L. Kellogg of Marshall, Michigan, who has logged stations from Chelmsford, England to Bandoeng, Java.

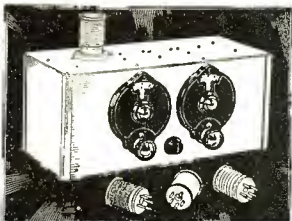

COMPLETE KIT

Everything necessary to build the complete four tube r.f. regenerative (non-radiating) short-wave set, including aluminum cabinet and two S-M Clough audio transformers.

- 730 Complete kit. \$51.00
- 730 Set, Wired.. 66.00

ADAPTER KIT

Complete with aluminum cabinet, less the two audio stages. Used with an adapter plug, it converts any broadcast receiver for short-wave use. Ideal for Television.

- 731 Adapter Kit. \$36.00
- 731 Adapter, Wired..... \$46.00

ESSENTIAL KIT

Contains the two tuning and tickler condensers, four wound plug-in coils, coil socket, and three r.f. chokes, with full instructions for building a 1, 2, 3, or 4 tube set.

- 732 Essential Kit. \$16.50

WE OWN AND OPERATE THREE AMATEUR STATIONS IN WHICH WE USE THE S-M 730 RECEIVER EXCLUSIVELY

**S-M 710 Sargent-Rayment Seven
"The Boss of the Air"**



This is the single-control set which "gets everything that's there." Real 10-kilocycle selectivity, and an uncanny ability to reach out for thousands of miles of distance. Four screen-grid tubes are used; the Clough audio system insures superb tone quality. List price: KIT, \$130, WIRED, \$175.

The New High-Power S-M Amplifiers

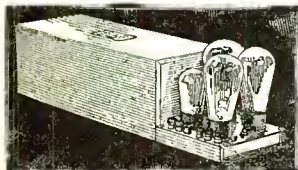

S-M 679 Amplifier. (For 690, see manufacturer's illustration on a preceding page.)

There is money for setbuilders in installing these new 250-tube S-M amplifiers in movie theatres and other public places.

S-M 690 has three stages, with two '50's in push-pull; the finest amplifier a theatre can have. List price \$245.

S-M 679, for smaller theatres and dance halls, has two stages: 1st stage '26, 2nd stage '50; two '81 rectifiers. Binding posts allow for record, radio, and microphone input. Clough audio transformers throughout. List price \$125.

MAXIMUM DISCOUNTS TO DEALERS AND SETBUILDERS. Prompt deliveries from stock on all S-M products, including the new 720AC All-Electric Screen-Grid Six. SEND THE COUPON.

—CHI-RAD—

CHICAGO RADIO APPARATUS CO., INC.

DEPENDABLE RADIO EQUIPMENT

415 SOUTH DEARBORN STREET - - CHICAGO

CHICAGO RADIO APPARATUS CO. INC. Dept. C3
415 South Dearborn Street, Chicago.

Please send your big catalog of S-M and other standard makes of kits, parts, and radio supplies, with best trade discounts to the setbuilder.

Name.....

Address.....

SM

**North-
West
Headquarters
for all S-M Products**



including
the
sensation
of the
Pacific Coast

S-M 710 Sargent Rayment Seven

"The Boss of the Air"—designed on the Pacific Coast to meet Western conditions, and having a record of consistent reception of East Coast and Japanese stations. Complete kit, including aluminum cabinet, \$130. Also WIRED.

Send us your orders for quick service. We carry complete stock of Silver-Marshall and other nationally known kits, speakers, cabinets, and accessories. SETBUILDERS—send the coupon at once for free catalog. Twenty-four hour service.

WEDEL COMPANY

ESTABLISHED 1888

520 Second Avenue Seattle, Washington

"The fastest Mail Order Service West of the Rockies"

WEDEL COMPANY
520 Second Avenue, Dept. CB3,
Seattle, Washington.

Please send your catalog, with best DISCOUNTS to me as a setbuilder.

Name.....

Address.....

SM

Get the Benefit of Our
Tremendous Stock—
Sales Volume—
Rapid Turnover—
on all the big Silver-Marshall
Kits—Wired Sets—Accessories

S-M No.	Name	Scr.-Gr. Tubes	KIT Price	WIRED Price
710	Sargent-Rayment Seven.....	4	\$130.00*	\$175.00*
720	Screen-Grid Six.....	3	72.50	102.00*
720AC	Screen-Grid Six (All-Electric).....	3	78.00	107.50*
730	"Round-the-World" Four.....	1	51.00*	66.00*
731	"Round-the-World" Adapter.....	1	36.00*	46.00*
732	Short-Wave Essential Kit.....	16.50
740	"Coast-to-Coast" Four.....	1	51.00	75.00*
740AC	"Coast-to-Coast" Four.....	1	53.00	78.00*
675ABC	High-Voltage Power Unit.....	54.00*	58.00*
678PD	2-Stage Power Amplifier.....	65.00*	73.00*

*Price includes metal shielding cabinet or case.

Write for Lowest net prices to Setbuilders
Send the coupon at once for the big new Allied Radio catalog

Allied Radio Corporation

711 W. Lake Street Chicago, Illinois

ALLIED RADIO CORPORATION, DEPT. SM3
711 W. Lake St., Chicago, Ill.

Please send free your new 1929 catalog with NET WHOLESALE PRICES to which I am entitled as a setbuilder.

Name.....

Address.....

City and State.....

SM **TRI-STATE HEADQUARTERS**
 PENNSYLVANIA—OHIO—WEST VIRGINIA

Quick service on anything in the Silver-Marshall Line. Orders shipped same day as received. Try us!

Get on Our Mailing List

CAMERADIO
 No. 1
 430 WOOD ST.
 at Diamond St.
 PITTSBURGH PA.

Write for Trade Discounts

Send for **WESTERN RADIO'S Latest 1929 Catalog**

FREE

THE New 1929 Catalog is crammed full of the **FINEST, NEWEST**, Nationally known A.C. sets, consoles, cabinets, dynamic speakers, kits, eliminators and accessories at **Lowest Prices**. Largest stock of radio parts. Prompt delivery. Write for our Free catalog.

WESTERN RADIO MFG. CO.
 128 W. Lake St., Dept. CB-3, CHICAGO



"The Big Friendly Radio House"

OFFICIAL NATIONAL WHOLESALE DISTRIBUTORS

For the **NEW**

Chassis **\$34.95** **COMMANDER** Chassis **\$34.95**
 NET NET

ALL ELECTRIC AC 6/7!

Designed and Factory Built for Us By
SILVER-MARSHALL, Inc.

WRITE TODAY FOR COMPLETE DETAILS

ALSO—We are Official National Wholesale Distributors and Headquarters for the Complete Silver-Marshall line. Adequate stocks of all S-M products carried at all times.

Setbuilders Supply Co.

106 Romberg Bldg. Chicago

Gentlemen: Send me your **FREE** Wholesale Catalog showing the Commander AC 6/7, the S-M line and a complete listing of other merchandise.

Name.....
 Address.....City.....State.....

SM **AUTHORIZED "SERVICE STATION"**

We are completely equipped to **SERVICE** and repair all **SILVER-MARSHALL PRODUCTS**.

RADIO SERVICE LABORATORIES
 (Harrison 2870)
 440 South Dearborn St. Chicago, Ill.

Lowest Wholesale Prices!

Set Builders and Dealers!

Let the largest Radio Mail Order House in the East serve you!

You'll get better service and better merchandise at the lowest wholesale prices obtainable anywhere.

NEW 1929 BUYING GUIDE

Your copy is ready for you. It lists all the latest Radio Parts, Accessories, Sets and Kits. Catalog K also lists Electrical Supplies, Household Appliances, Golf and Tennis Equipment, Cameras, Traveling Bags, etc. Send for your copy now. It's free.

Allen-Rogers-Madison
 35 WEST 31ST. INCORPORATED NEW YORK, N.Y.

HEADQUARTERS For Set Builders and Dealers

We are the Wisconsin distributors for Silver-Marshall Kits Tyrman Kits Scott Screen Grid Nine Robertson-Davis Thordarson and other popular merchandise. We can furnish you within ten hours the parts for the above circuits and others as specified in the **CITIZENS RADIO CALL BOOK**. Mail orders filled promptly.

RADIO PARTS CO.
 311 State St. Milwaukee, Wis.

Acme Parvult	
Aero	Amertran
Bodine	Benjamin
Browning-Drake	
Carter	Centralab
Daven	Eby
Electrad	Elkon
Hammarlund	
Jensen	
Knap	Lynch
Madison-Moore	
National Co., Inc.	
Newcomb Hawley	
Raytheon	
Samson	Pacent
Sangamo	
Scott	
Silver-Marshall	
Sylvania	
Thordarson	
Tobe	
Tyrman	
Victoreen	
Ward-Leonard	
Weston	Yaxley

SET BUILDERS

Write us for new illustrated Catalog "C-3" containing all the new and popular kits in radio. Our tremendous stock enables us to give you immediate service on all radio supplies at wholesale prices.

Allied Radio CORPORATION
 711 W. LAKE STREET, CHICAGO

FREE!

LAST CHANCE

YOU can enjoy the perfect reproduction and the unusual convenience of this Midget Cone Speaker absolutely free. Manufactured by one of the largest manufacturers in the country, this speaker has innumerable advantages in portability and perfect tone. Ideal for apartment use, or in different rooms of the house, the Midget Speaker is delighting thousands who are now using it.



From Elizabeth, N. J.:

"I received the Midget speaker today. It's great and I am well pleased."

Richard Ogden.

From Ocean Breeze, Cal., W. P. McGuide writes: "I received your Midget Speaker and sure was surprised by its performance. I play all distant stations just as good as any speaker I've had, and it performs dandy."

One of these speakers may be yours absolutely free, by just filling in the coupon below for one year's subscription to the Citizens Radio Call Book Magazine. Because the supply is limited, do not delay in sending in the coupon. Remember this is your last chance.

Mail Coupon Today!

CITIZENS RADIO CALL BOOK MAGAZINE 508 So. Dearborn St., Chicago, Ill.

Here's my \$1.75 (Foreign \$2.00), for which please send me Citizens Radio Call Book Magazine for one year, beginning January March September November.

This subscription entitles me to a free Midget Loudspeaker.

NAME.....

ADDRESS.....

CITY..... STATE.....

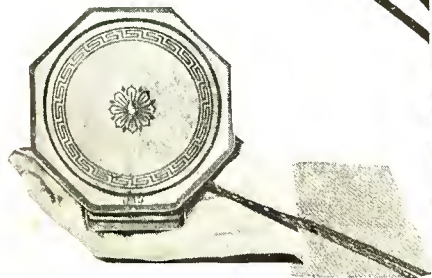

Tell 'Em You Saw It in the Citizens Radio Call Book Magazine and Scientific Digest

Quality Long Life

Potter Condensers

Uniformity Economy

The operation of your radio set is insured by the use of Potter Condensers built to meet your requirements.

Potter Condensers are built from the best materials in a factory devoted to the exclusive production of condensers.

There is a Potter Condenser made for each requirement and should be selected with care.

Potter Filter Blocks



- T-2900** Condenser Block for the single 250 type tube amplifier **\$20.00**
- T-2950** Condenser for the push-pull 250 type tube amplifier **\$22.50**
- T-2098** Condenser Block for single 210 type tube amplifier **\$20.00**
- T-280-171** Condenser Block for power pack with 280 type tube rectifier... **\$18.00**
- SM-673** Condenser Block for Silver-Marshall power amplifier and power supply units..... **\$20.00**
- SR-210** Condenser Block for power supply unit for 210 type tube..... **\$15.50**
- SR-210A** Condenser Block for power supply unit with 210 type tube located in power pack... **\$20.00**

Potter By-Pass Condensers

Code	Cap.	Working Voltage D.C.	Size	Price
A-1	.1 Mfd.	160	7/8"x3/4"x1 1/8"	\$0.60
A-2	.25 "	160	"	.70
A-3	.5 "	160	"	.75
A-101	.1 "	200	"	.70
A-102	.25 "	200	"	.75
A-301	.1 "	400	"	.85
A-401	.1 "	500	"	1.00



Code	Cap.	Working Voltage D.C.	Size	Price
A-4	1. Mfd.	160	1 1/8"x3/4"x2"	\$0.90
A-103	.5 "	200	"	.90
A-104	1. "	200	"	1.25
A-302	.25 "	400	"	1.00
A-303	.5 "	400	"	1.25
A-402	.25 "	500	"	1.25



Potter Interference Eliminator

Enjoy radio broadcast programs normally spoiled by interference from oil burner, ice machine motors, fans, violet rays, vacuum cleaners, etc.

Simply connect a Potter Interference Eliminator to the line circuit at the point where interfering device is connected and your troubles will be over.

105-05 Interference Eliminator for oil burner and ice machine motors of 110 volt 60 cycle operation. **\$3.75**



The Potter Co.

North Chicago, Illinois
A National Organization at Your Service

Two Audio Transformers Are Added to Citizens Junior Two Tube Set

(Continued from page 48)

- 1 Birnbach .00035 r. f. transformer
- 1 Birnbach .00035 three-circuit coupler
- 1 R-151 Thordarson 6-1 audio transformer
- 1 R-152 Thordarson 2-1 audio transformer
- 1 4 Yaxley 2 ohm fixed resistance
- 1 Durham 3 megohm grid leak
- 1 Formica 7x18x3/16-inch black front panel
- 1 7x17x5/8-inch wood sub-panel
- 1 Formica 1x18x3/16-inch terminal strip
- 13 X-L bakelite binding posts
- 4 530 Frost UX sockets
- 2 Kurz-Kasch 4-inch plain dials
- 1 10 Yaxley line switch
- 1 Amsco grid leak mounting
- 1 Package Corwico Braidite hook-up wire
- 1 Package Kester radio solder
- 4 Ceco or Sonaton 01-B tubes

Citizens Booster Stage Is Operated from A.C. Light Line

(Continued from page 52)

- 1 Birnbach special r. f. transformer
- 1 85 Hammarlund 85-mh r. f. choke
- 1 71000 Yaxley 1000 ohm fixed resistor
- 1 820C Yaxley 20 ohm center tapped resistance
- 1 Formica 4 3/8x8 1/2x3/16-inch ivory sub-panel
- 1 Birnbach 5-wire cable
- 1 9040 Benjamin UX socket
- 1 Aluminum Co. of America stage shield
- 1 Package Kester radio solder
- 1 Ceco or Sonatron 226 type tube
- 1 Package Corwico Braidite hook-up wire

Tube Tester Made for Professional Set Builders' Laboratory

(Continued from page 60)

- 1 Formica 15 x 18 x 1/8 inch black front panel
- 7 138-A General Radio binding posts
- 2 Eby UV sockets
- 2 Eby UY sockets
- 1 64 Yaxley 4PDT jack switch
- 1 60 Yaxley DPDT jack switch
- 1 30 Yaxley SPDT jack switch
- 1 40 Yaxley DPST jack switch
- 3 10 Yaxley SPST jack switches
- 1 342 Carter screen grip cap connector

Thordarson R480 Power Amplifier Uses 171's in Push Pull

(Continued from page 61)

particular portion of the resistance is not used in this job. A single 1000 ohm Electrad fixed resistance is used as a means of securing the bias on the grids of the two 171 tubes and this resistance is located between the center tap of one of the 5 volt secondaries and the common B minus line of the system. This resistance is bypassed by a 1 mfd condenser to insure absence of hum from this particular portion of the circuit.

As shown in the schematic, the various resistance sections of the voltage divider are bypassed with their respective 1 mfd condensers, while the filter section contains one 2 mfd and two 4 mfd sections. These are all contained inside of the Potter condenser block designed for the R-480.

Solving the X Resistance

For that uncertain resistance in the circuit—uncertain because of uncertain signal strength, fluctuating voltage, variations in tubes, and other unknown factors—turn to the CLARO-STAT as the solution of the X resistance. A turn of the knob or screw, and you have the precise resistance value. No guessing. No mathematics. No nerve-wracking formulas. No crude makeshifts. No uncertain results. And don't forget: There's a CLAROSTAT for Every Radio Purpose—

For use in the radio assembly itself, there's the Grid Leak, Volume Control, Standard and Power CLAROSTATS, with knob for easy adjustment of resistance.



For semi-permanent resistance, in the radio set or power unit, there's the Duplex CLAROSTAT, instantly adjustable with a screwdriver, yet free from meddling.



For external use in controlling volume, tone or sensitivity of radio set or phonograph pick-up, there's the handy Table Type CLAROSTAT, and the heavier Speed Control CLAROSTAT for motor and television uses.

In many styles, sizes, mountings and ranges, the CLAROSTAT is a truly universal resistance that takes the guesswork out of radio. Whether your set is being planned or is already built, new or old, manufactured or home-made, good or bad or indifferent—the CLAROSTAT, properly applied, will make it a better set.

CLAROSTAT
Mfg. Co., Inc.
Specialists in
Radio Aids
285 N. 6th St.
Brooklyn, N. Y.

Write for data on the complete line of CLAROSTAT products and how to apply them. Better still, send 25 cents for the "Gateway to Better Radio", 32-page book with 20,000 words and 83 illustrations. Invaluable to every radio fan!

3 YA K E N J

New Zealand and Honolulu on the broadcast band

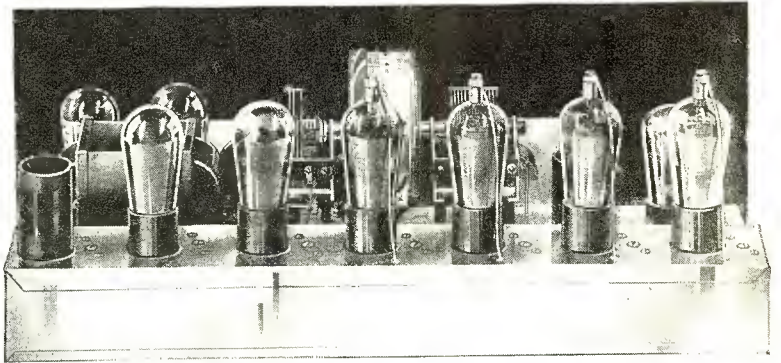

The HFL Special Nine

With the New 250 Power Amplifier

Now you can get through. Far out into the real air lanes where things happen. Guitars and singing señoritas in Mexico. Jingle bells on a husky's neck in snow-bound Alaska. Languorous melodies from some Hawaiian terrace. A German band . . . German in every umpp, from staid old Berlin, 3,000 miles away.

Man, get yourself a set that goes out and gets 'em. One dial in front, but behind the panel a glistening vision of 1930 radio. A battleship chassis—all steel and copper. Stripped down for ac-

tion, and it's just too bad when you let her go!

No frills on this job. It's the Super you have dreamed about. Absolute one spot tuning. All the selectivity and "sock" that four screen grid stages can produce. The 250 amplifier takes care of the tonal quality. It's gorgeous.

And sensational prices. The A. C. set, \$61.74. D. C. model, \$55.86. 250 amplifier and B supply, \$45.28. Send for all the dope TODAY. Set builders write on business letterhead for special offer.

---SEND THIS COUPON---

HIGH FREQUENCY LABORATORIES
Office 11 — 28 North Sheldon Street, Chicago, Illinois
Gentlemen: Without obligation, please rush literature on your new 1930 products.

Name _____
Address _____
City _____ State _____
(Please print plainly)

HFL

LIFE-TIME DX AERIAL No. 30

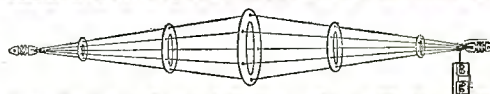

Length 30 ft.
Non-corrosive—
30 ft. length—
volume of 150
feet aerial with
selectivity of 30
foot antenna.
Assembled—ready
to string up—all
connections sol-
dered or riveted.

Guaranteed Double Volume and Sharper Tuning

Rings are heavy gauge solid zinc. Permits using a powerful aerial in 30 ft. space. Duplicates in design and material. The aerials used by largest Broadcasting Stations. Sharpens tuning of any set, because of short length, but has enormous pick up because 150 ft. of enameled 12 ga. wire is used. Insures more uniform reception. Non-corrosive feature insures long life and 100% efficiency at all times. "Truly a Life Time DX Aerial." List **\$10.00**

No. 60—Length 60 ft. Price \$12.50

"Big Box" size. Best for European tests. (Same description as above, except that 300 ft. of wire is used making this the most efficient and powerful aerial ever made.)

Manufactured by
THOROLA RADIO PRODUCTS 110 E. 21st St. Chicago, Illinois

The foundation for efficient operation of the next set or power pack you build

POLYMET Filter Blocks and Wire Wound Resistances—especially designed for various rectifying tube requirements.

POLYMET Filter—By-pass—Molded Mica Condensers—Metallized Grid Leaks—for radio, short wave, and television circuits.

POLYMET Center Tapped—Flat—and Flexible Resistances for A.C. tubes.

If your local dealer does not handle Polymet, write us direct.

Our latest catalogue shows how to build many popular circuits with Polymet essentials—send for a copy today.

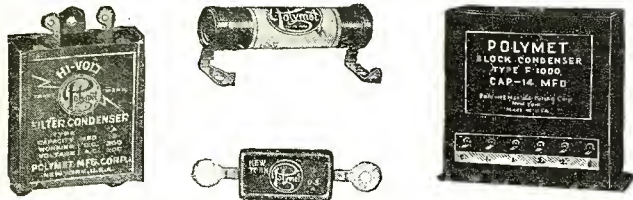

POLYMET MANUFACTURING CORP.

609 Broadway

New York City



POLYMET PRODUCTS

Input to the push-pull audio system is through a Thordarson T-2922 audio transformer, having a single primary and a push-pull secondary leading to the grids of the 171. The output circuit of the push-pull arrangement is through a Thordarson T-2420 output choke, the center tap of which goes to the high voltage lead of the rectifier and the speaker terminals going across the two extremities of this output choke. The T-2420 is used as an output choke for high impedance speakers. If a dynamic speaker is to be used, this unit should be changed for the type T-2903 speaker coupling transformer. When this transformer is used, the output transformer in the dynamic speaker should be disconnected and the movable coil in the speaker connected directly to the output or secondary terminals of the T-2903.

If high frequently cut-off is desired, two small fixed condensers about .002 mfd should be used across the plate winding or primary of the T-2903 transformer. One condenser should be connected from one outer or plate terminal to the center or B plus terminal, and the other condenser should be connected in a similar manner across the other half of the primary of this transformer. Because of the limited output of the rectifier tube, there is no provision for supplying the field of the dynamic speaker from the amplifier. The dynamic, if used, should either have a 6 volt d. c. field or a field operating from alternating current.

In some cases where comparatively larger currents from the 45 volt tap are required, it is necessary to lower the value of the resistance between the 45 and 90 volt taps. When using the Thordarson resistors it is impossible to make the change in the divider itself, but it may be easily accomplished by merely connecting a 10,000 or 15,000 ohm potentiometer in parallel with this portion of the divider. The 45 volt supply is then taken from the movable arm of the potentiometer instead of from the tap, and the arm varied for desired results.

When using the Electrad resistors the slider arm may be moved to lower the resistance.

The plate voltage for the primary of the input transformer T-2922 may be either 45 or 90 volts, as found best by the operator. In the schematic diagram, it will be seen that the P terminal of the input audio transformer goes to the plate of the first audio.

Official Parts List

Parts required for the construction of the Thordarson R-480 power amplifier as described here are shown below:

- 1 Thordarson R-480 power compact
- 1 Thordarson T-2922 push-pull input transformer
- 1 Thordarson R-2420 push-pull output choke, or Thordarson T-2903 push-pull output transformer
- 1 Electrad resistance unit 1-T
- 1 Potter R-480 condenser block
- 1 Electrad 1000 ohm fixed resistance
- 8 X-L binding posts
- 3 Benjamin UX sockets
- 1 Wood baseboard $\frac{3}{4} \times 8\frac{1}{2} \times 12\frac{3}{4}$ inches
- 1 Pkg. Kester radio solder
- 1 Pkg. Corwico Braidite hook-up wire
- 1 Ceco or Sonatron rectifier tube
- 2 Ceco or Sonatron 171 power tubes

Many Combinations Possible with the Walker Multi-Unit

(Continued from page 64)

be calibrated, although from a laboratory standpoint too much accuracy need not be expected from this particular procedure.

Diagram No. 14 shows the unit as a short wave, shield grid pre-amplifier. No. 17 shows the unit as a wave-meter, with either a small flashlight bulb or a neon tube across

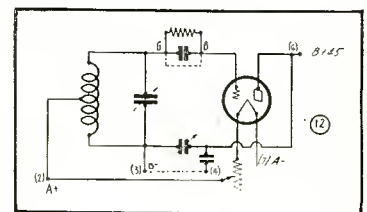

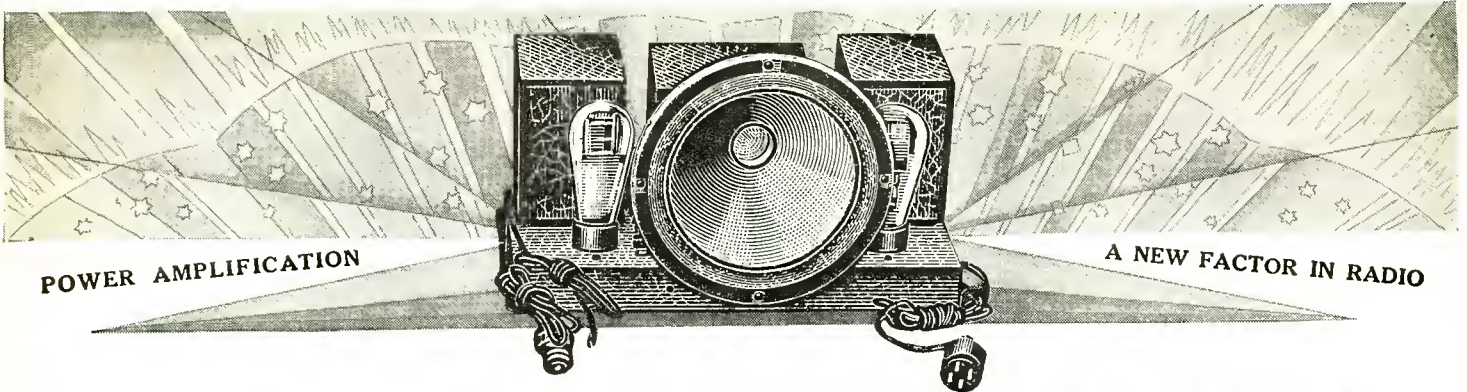

MAKES 1928-1929 RECEIVERS SUPER POWER
 (Also applies to 1925 to 28 sets)

FIDELITONE provides super audio power for the home—Accomplishing in amplification the same clarity of tone that has been the delight of audiences in the largest theatres and auditoriums.

Reproduces the music of a solo or orchestra as if the musicians were personally present.

CONNECTS WITH ANY RADIO
 Fits in usual cabinet without altering position of Dynamic Speaker.

Assures marvelous music of **FULL EXPRESSION** with clear and exacting **FIDELITY OF TONE**.

PRICE \$39.50 LESS TUBES AND SPEAKER 1 1 1 *Write Today for Literature*

fidelitone
FIDELITY OF TONE
WEBSTER Company
 of CHICAGO
 850 Blackhawk Street Chicago

Readrite

Universal Test Set

Complete Outfit, Shown One-Half Scale

Operates equally well on A. C. or D. C. circuits. Just the thing for service man or set owner. A trouble shooter and tube tester combined. Order one today. Literature for the asking.

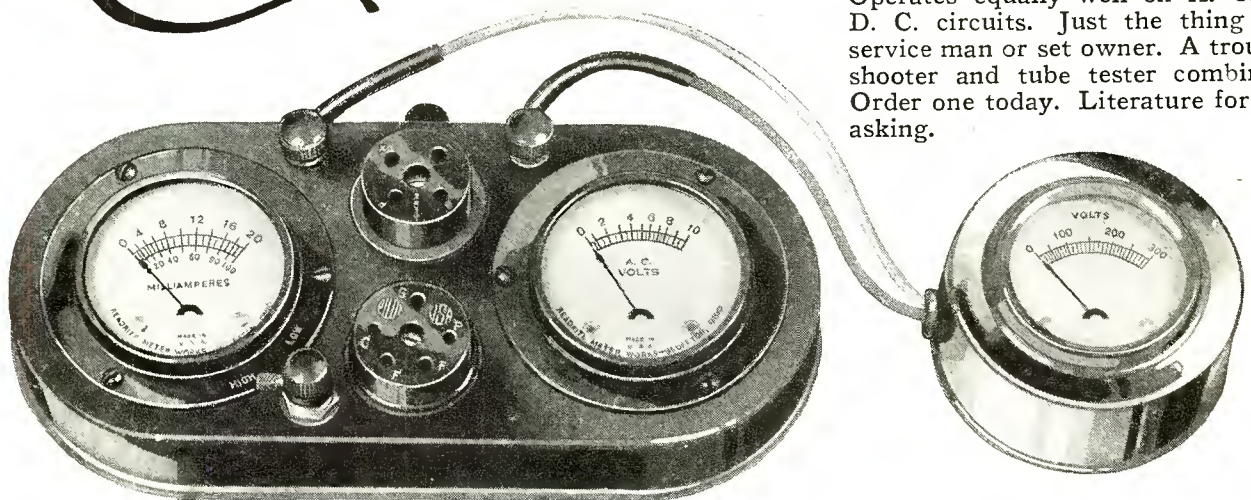

\$17⁰⁰
 LIST

READRITE METER WORKS
 Established 1904

10 College Ave. Bluffton, Ohio

Ace High in Performance

The difference between ordinary resistances and Electrad Resistances often means the difference between a poor unit and one of super-fine performance.

That is why experienced set and eliminator builders insist on Electrad Resistances wherever variable, fixed or tapped resistances are required for control in their circuits.

TRUVOLT All-Wire RESISTANCES

Reg. U. S. Pat. Off.

U. S. Pat. No. 1,676,869 and Patents Pending

In Truvolt Variable Resistances, the contact arm slides lengthwise over the turns of resistance wire; hence there is practically no wear on the resistance element. Their easy "potentiometer" control eliminates difficult calculation, and permits exact adjustment to tubes and line voltages.

An exclusive feature of Truvolt Fixed Resistances is that the values can be quickly set at any point desired by the use of sliding clip taps.

Royalty Variable High Resistances

Exclusively licensed by Technidyne Corporation Under U. S. Patent Nos. 1593658, 1034103, 1034104.

A standard resistance widely recommended for its accuracy and dependability wherever variable high resistances are required.

Made with the best insulating materials and free from injurious inductance and capacity effects. Same resistance always secured at same point. Entire range of resistance covered in one turn of knob.

There is a type for every radio purpose—11 in all, \$1.50 each. Potentiometer, \$2.00.

Electrad specializes in a full line of resistances and controls for all radio purposes.

Tear out and mail coupon for complete FREE circulars and full information

----- CUT HERE -----

ELECTRAD, INC., Dept. CR3, 175 Varick Street, New York.

Please send me descriptive circulars on the following products and put me on your mailing list for similar literature.

-General Circular.
-Touatrol Volume Controls.
-Phasatrols.
-Royalty Variable Resistors.
-"Electrad Control Manual" (Enclose 10c. for mailing).
-"What B Eliminator Shall I Build?" (Enclose 10c. for mailing).
-Truvolt Divider Manual (Enclose 10c. for mailing).

I am particularly interested in.....

Name.....

Address.....

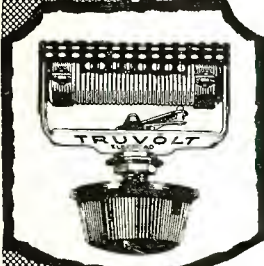
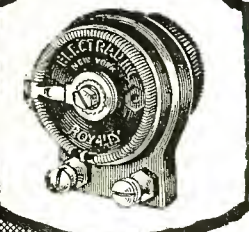

ELECTRAD Inc

the plates of the condenser to indicate resonance.

If anyone is experimentally inclined, there are certainly enough possible combinations with the Walker Multi-Unit to please even the most exacting. The principal appeal of this particular unit lies in the fact that everything is provided within the unit for any circuit arrangement which the experimenter may wish to make. Heretofore it was necessary to tear down and build up again after each new combination but in this case with the unit quite flexible considerable time may be saved from one experiment to another.

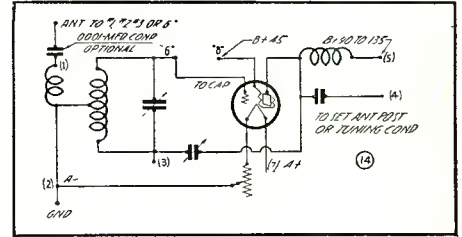

The unit includes a four lead plug in adapter, short wave plug-in coil, regular wave plug-in coil, screen grid tube prop clip, antenna fixed condenser, extra hookup wire, and connector links. The panel is of engraved bakelite with bakelite vernier dial, bakelite control knob, tuning condenser, midget condenser, rheostat, choke coil plug-in, coil socket, etc. Instructions which accompany the kit are clearly written and understandable by the novice or layman.

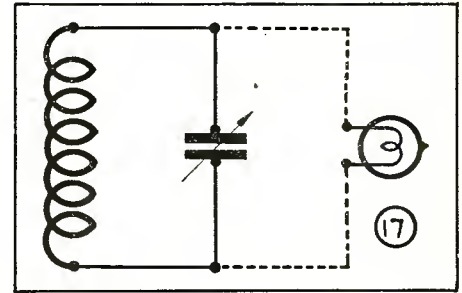

When the Multi-Unit is used with an a. c. receiver and employed as a short wave adapter, there are two methods of connection. One incorporates the use of an extra filament supply, consisting of a 6 volt wet or dry battery, and the other method is with the use of the new Walker No. 227 A. C. adapter plug, which is now available.

The first method will find favor in that a d. c. tube of the 200-A or 112-A type may be used. This permits free oscillation of the detector which is lacking in the 227 type of tube. The latter method is very convenient in that the filament and plate connection to the receiver is made simply by plugging in the adapter plug from the unit to the detector socket of the set. This method provides for use of the 227 a. c. detector tube.

With the advent of spring and summer with its disturbing static interference and weaker signals, it is believed that the Multi-Unit will find a welcome place in the hands of the conservative and exacting radio fans. When the unit is used as an extra stage of tuned radio frequency a shorter antenna may be employed, depending upon the unit to build up the signal in volume. With the tuning of short wave stations there is little static to mar the signal clarity.

New Silver-Marshall 720 A. C. Set Uses UY 224 and UX 245 Tubes

(Continued from page 46)

- 1 Yaxley 1500 ohm resistor
- 1 Yaxley 840-C center-tapped resistor
- 1 Ohmite 1500 ohm resistor
- 2 Potter 104 1 mfd condensers
- 7 Sprague or 1/4 mfd condensers
- 1 Polymet .00015 mfd grid condenser with clips
- 1 Polymet .002 mfd bypass condenser
- 1 Polymet 2 megohm grid leak
- 1 Durham .15 megohm resistor with leads
- 3 Moulded binding posts consisting of 8/32 screw, nut and top
- 1 Set hardware

Tell 'Em You Saw It in the Citizens Radio Call Book Magazine and Scientific Digest

Once Again, Please!

Just twelve months ago we asked our readers to indicate to us on a questionnaire the type of editorial material they wished in the magazine and also any suggestions they might have as to the manner in which we could serve them.

We received an unprecedented response to that questionnaire, which appeared in the March, 1928, issue, and as a result of the information so gained we patterned our editorial content after the desires of a majority of our readers.

In the short space of twelve months there has been much progress made in radio and undoubtedly our readers have progressed along with the industry, so we naturally feel that our readers may desire further changes for the next twelve months.

Accordingly, we are requesting our readers to once again help us meet their wishes by filling out the questionnaire in the lower portion of this page and mailing it to our office. The results will be immediately tabulated and the information thus gained will enable our editors to prepare the type of editorial material most earnestly desired by the 200,000 who see our book.

1. Do you wish more matter like that shown in the Power Amplification Section on page 73 of this issue?
2. Do you now favor a. c. sets instead of d. c. sets?
3. Do you read the ABC of Radio Department?
4. Do you like the "gadgets" (small jobs) presented in this issue?
- 5: Are you interested in television?
6. After reading over this issue, do you feel thoroughly satisfied with its contents?
7. Do you find it more profitable to sell and service factory sets than to be a custom builder?
8. From whom do you buy your radio parts?
9. Will a schematic diagram of the leading set manufacturers, such as Howard, Crosley, Atwater-Kent, Sparks-Withington, RCA and others containing helpful hints on service and trouble be of assistance to you in your work?
10. Please indicate in the proper blank the classifications into which your vocations falls.

Cut Out Along Dotted Line and

Mail to Citizens Radio Call Book Magazine, 508 S. Dearborn, Chicago, Ill.

Question	Yes	No	Question	Yes	No
1			5		
2			6		
3			7		
4			9		

Question 8.

Manufacturer

Jobber

Dealer

Question 10.

Radio Manufacturer

Radio Engineer

Retailer

Wholesaler

Service Man

Custom Builder

Name _____

Address _____

City _____

State _____

Phone No. _____

**BRING 'EM IN
CLEAR
AND
QUICK
WITH**



**ARCTURUS
A-C LONG LIFE TUBES**

**ARCTURUS RADIO CO.
NEWARK, N.J.**

AEROVOX
BUILT BETTER
CONDENSERS AND RESISTORS

What Is Back of Such Phenomenal Growth?

In July, 1928, the large plant of 20,000 square feet occupied by the Aerovox Wireless Corporation for the manufacture of condensers and resistors exclusively, proved inadequate to meet the demands of the trade for Aerovox condensers and resistors. An additional 10,000 square feet, added in August, 1928, relieved the situation temporarily, but in January, 1929, it was found necessary to add another 15,000 square feet and additional machinery and facilities to keep up with the demand for Aerovox Products.

Such a phenomenal growth, which has made it necessary to more than double the capacity of the plant in the short space of six months, can be due to no other reason than the pursuance of a policy of manufacturing only the best condensers and resistors that can be produced, at a price as low as possible consistent with quality and safety.

AEROVOX WIRELESS CORP.
72 Washington Street, Brooklyn, N. Y.
PRODUCTS THAT ENDURE

Adding Tube Shield Boosts Range of Aero International Four

(Continued from page 50)

- 1 No. 520 Yaxley rheostat 20 ohms
- 1 No. 500 Yaxley switch for rheostat
- 1 No. 639 Yaxley cable connector and plug
- 1 No. 810 Yaxley resistance 10 ohms
- 1 No. 815 Yaxley resistance 15 ohms
- 1 Aero coil kit type LWT-10
- 2 Aero Noskip choke coils type No. C-60
- 1 Aero International Antenna adapter type No. C-65
- 1 No. 2 ballast
- 1 Type E National illuminated dial
- 1 Carter tube shield and ring for mounting
- 3 Black Kurz-Kasch knobs
- 1 No. 342 shield grid connector
- 2 No. AE-770 Aero audio transformers
- 1 Eby Junior binding post
- 1 Allen-Bradley grid leak 10 megohms
- 1 Aero bushing for dial shaft
- 1 Pkg. Kester radio solder
- 1 Pkg. Corwico Braidite hook-up wire

The Hollister AC-8 Electric Operated Super Is Now Available

(Continued from page 55)

- 1 Front Lithographed Panel.
- 2 Binding Posts.
- 7 1 mfd Condensers.
- 1 Carter TP 3 M 3000 ohm Potentiometer
- 4 Electrad 3000 ohm Resistors.
- 1 Electrad 2000 ohm Resistor.
- 1 Yaxley 1500 ohm Resistor.
- 2 Carter CU60 Center Tapped Resistors.
- 1 S-M No. 275 Choke.
- 1 Aerovox .00015 Condenser with Clips.
- 1 Aerovox 2 Megohm Grid Leak.
- 1 Sangamo .00007 Condenser.
- 1 Aerovox .002 Bypass Condenser.
- 1 Carter 110 a. c. Switch.
- 2 Tip Jacks.
- 1 Terminal Strip—Jones.
- 1 Cable—Jones.
- 2 Knobs for Potentiometer and Switch.
- 1 Set Hardware and Wire.
- 3 Diatron or LaSalle 227 Tubes.
- 4 Shieldplate a. c. 22 Tubes.
- 1 Diatron or LaSalle 210 or 250 Tube.

Automatic Tuning or Single Dial in Robertson-Davis Super Six

(Continued from page 66)

output stage. If, when the primary of the input transformer is shorted, there still exists a considerable hum, either the plate current is not sufficiently free from alternating current component, the center tap of the filament winding is too far out of balance, the grid bias resistor bypasses insufficient or there is too much magnetic pick-up in the coupling transformer in that stage. In regard to the presence of alternating current component in the plate current supply, the cause may be defective rectifier tubes, a short circuit in the choke coil, alternating current supplied to the filament or power supply transformer has a high noise factor, poor wave form of the alternating current supply, changing frequency or bad harmonic, open or leaky filter condensers or filter condensers of insufficient capacity. All filament leads that carry alternating current should be twisted. Twisted filament leads running from the set to the amplifier should be



THE Shanco Clip design assures free and uninterrupted flow of electrical current. There are no springs to heat up, burn or drop out. Made of powerful tension, tempered spring steel solidly riveted together. All parts electro-plated before assembly (not galvanized or tinned), acid-resisting. The jaws open wide and are easily applied. The Griptite bulldog teeth "stay put" and bite right through corroded bars and terminals. The teeth are so arranged that the clip cannot fall over and "short" the battery.

There are 4 sizes for every battery need: 5 Ampere, 15 Ampere, 50 Ampere, 300 Ampere.

Write for our literature and prices

Shanklin Manufacturing Company
Dept. 64, Springfield, Illinois

It's Impossible to Fail

WITH the Roberts Short Cut to the code, anybody can learn the code in one evening. Designed by a naval officer to teach operators for war purposes, when speed was paramount.

Fifty Cents, U. S. Stamps or Coin

Used in schools and by thousands of students, the world over. No phonograph records or mechanical devices needed. Just send 50c in stamps and you will get a thrill from receiving messages from every country in the world.

FAILURE IMPOSSIBLE

Remember—No Tedious Weeks and Months—One Night and the Code Is Mastered

Roberts Radio Service
780 Caxton Building, Chicago, Ill.

MAKE GOOD RECEPTION EASY

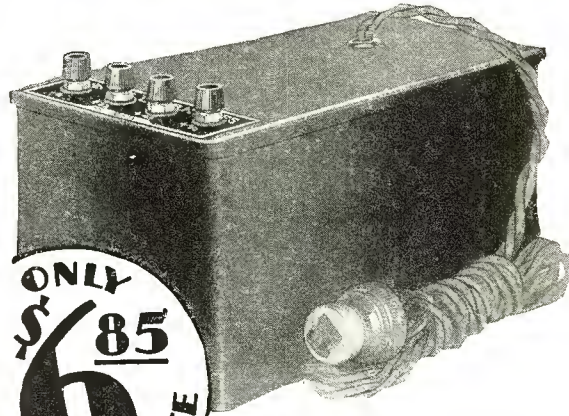

TOWNSEND "B" Power Unit

Thousands of users marvel at the difference in reception with a Townsend "B" Power Unit. Full, sweet tone, clarity, volume and greater distance are among the many advantages reported daily. Hooked up in a few minutes; just plug into the light socket and forget it. Delivers up to 100 volts on any set—D.C. or A.C.—any cycle.

Over 100,000 Now in Use

There's no longer any reason for putting up with the expense, the inconvenience and undependable performance of "B" Batteries—when you can own a good "B" Power Unit for the surprising, low cost of \$6.85. Over 100,000 Townsend "B" Power Units now in use—a substantial proof of satisfaction.

SEND ONLY \$1.00

Fill in coupon and send with only \$1.00. Prove this marvelous value to yourself. Use it ten days. Then if it fails to do everything we say, return it and money paid us will be refunded. Make a REAL receiver of your set.

APPROVED and PASSED by the rigid laboratory tests of "Popular Radio" and "Radio News."

TOWNSEND LABORATORIES
Dept. 26, 713 Townsend St., Chicago, Ill.

These Have— So Can YOU!

Eliminator is a wonder. Have had it almost three years and no trouble at all with it.—Earl C. Brohier, Marble Park, Ia.

Have had Eliminator for two years and got the best of results from it.—Chas. O. Snodgrass, Mingo Jet., Ohio.

Have used Eliminator for over a year and find no fault with it.—Sgt. J. H. Zarling, Field Artillery School, Ft. Sill, Okla.

Have used your Eliminator for over a year and more than pleased with it.—W. M. Schmidt, Santa Ana, Calif.

Eliminator working great. Worth its weight in gold.—Henry W. Ertle, Wilkes-Barre, Pa.

Eliminator works just fine on my RCA. Gives me no trouble at all.—A. D. McComas, St. Albans, W. Va.

Have used Eliminator for over a year with fine results.—J. L. Davis, North Vernon, Ind.

Your Eliminator has held up fine.—E. K. Walsh, Norfolk, Va.

Eliminator bought from you last winter is all that you claim it to be and more.—P. M. Lauer, Alliance, Nebr.

Eliminator bought some time ago works just fine.—Robert F. T. Preusse, Falls City, Nebr.

Have had Eliminator about a year and it sure has given good service.—E. E. Billingsme, Waco, Texas.

Eliminator works wonderful on our GREBE.—Alex S. Stirling, Romeo, Mich.

ATTACH ONLY \$1.00 TO THIS COUPON

Townsend Laboratories,
Dept. 26, 713 Townsend St.,
Chicago, Illinois. 3-29

Gentlemen:
Attached find \$1.00. Kindly send at once Townsend "B" Socket Power Unit, C.O.D. \$6.85, plus postage, on guaranteed 10-day Free Trial.

Name.....
Address.....
City.....State.....

This Catalog Will Save You Time and Money

Write today for our large illustrated new Catalog "C-3," showing how this organization of men with years of experience, can give you personal service.

Allied Radio CORPORATION
711 W. LAKE STREET, CHICAGO

POLK BINDING POST

SENSATION OF THE NATION

INSULATED

No holes to fish for—just press the sleeve and insert the wire in any position—quick action and holds tight—standard markings.

15 cts. each

J. L. POLK, 41 Belle Ave., Troy, N. Y.

EBY SOCKETS—

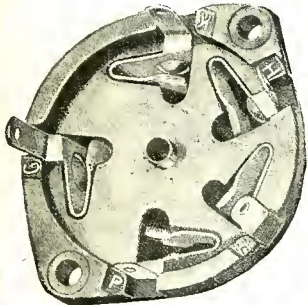
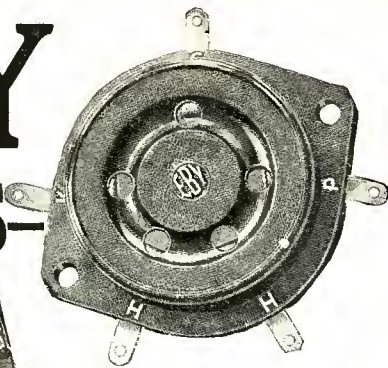

PERFECT CONTACT

Bottom view without base, showing contacts

1. Efficient in action and attractive in appearance.
2. Can be mounted above or below any panel.
3. A groove in the top guides the tube prongs into the socket.
4. Spring action of the phosphor bronze contact prongs cannot be weakened, —no matter how many times the tubes are inserted or withdrawn.

The H. H. EBY MFG. CO., Inc.
4710 Stenton Avenue Philadelphia, Pa.

B RNBACH EXTENSION CORD "It's moisture-proof"

Enables You to Place Speaker Where
It Will Give Best Reception

YOUR radio receiver must be placed where it will harmonize with the other furnishings of the room and where antenna and ground wires can be easily brought in. With the Birnbach Extension Cord, you can properly place your receiver and put the loud speaker in front of a tapestry window, behind a screen, in a corner or wherever it gives the best acoustical reception. In addition to this advantage, Birnbach Extension Cords enable you to carry your loud speaker into any room in the house, thus making radio reception available in any room without moving the radio set.

The New Birnbach Extension Cords are available in four attractive colors, Old Gold, Maroon and White in the silk; and Brown, in moisture-proof. These colors will harmonize with any color scheme of home decoration. A thorough insulation of rubber over the strands of copper wires in the Birnbach Moisture-Proof Extension Cord, prevents leakage from one conductor to another, and eliminates the frequent cause of a scratchy noise in the speaker.

Your dealer has these sizes in stock, 10, 20, 30, 40, 50 and 100 foot lengths, or write us

BIRNBACH RADIO CO.
254 West 31st Street NEW YORK, N. Y.

kept separate from the other leads. Alternating current hum is often present in the speaker itself. If a speaker using 110 volt a. c. supply is used, the 110 volt supply plug should be reversed to determine its best position.

Great care should always be exercised when investigating a power amplifier because of the high voltage involved. A very good habit to acquire is to connect the amplifier from the 110 volt supply before making any changes or tests. If on test it is determined that your 110 volt line is extraordinarily high or extraordinarily low, a report of this fact should be made to the electric light company so that they can investigate and ascertain the cause. A 5 volt change plus or minus would not be indicative of anything amiss, but 20 and 25 volt deviation either above or below 110 volts might indicate that something abnormal exists.

Modulated Oscillator Handy Device to Have About the Workshop

(Continued from page 69)

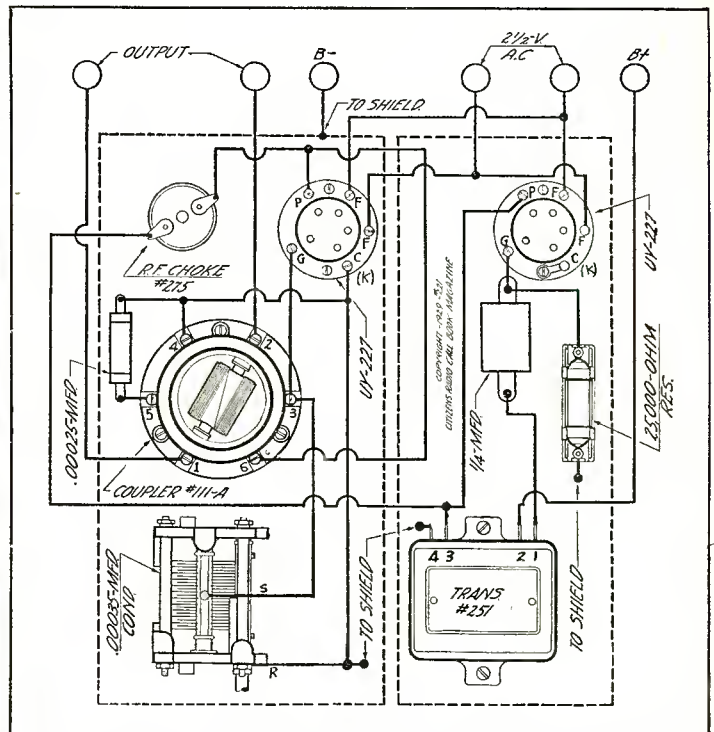

Fig. 3. The graphic diagram of the modulated oscillator is shown above and this drawing will serve for those who are not so accustomed to working from a schematic circuit

used to determine the frequency of some broadcast station. If the calibration has been carefully made and if the heater and B battery voltages are kept reasonably constant, and using the same 227 r. f. tube, it will be accurate within a fraction of 1 per cent. When fishing for distant signals, the oscillator, with the a. f. tube removed, may be made to beat with the dx station and produce an audible signal before the set has been closely enough adjusted to give a reasonable signal from the station itself.

The radio frequency oscillator may be used to match coils and condensers, measure coil and circuit losses and for a large number of common laboratory tests.

Used as Audio Oscillator

Used as an audio frequency oscillator, the unit should be connected so that the circuit to be supplied is in series with the negative B battery lead. If the external circuit is not continuous, a 1000 ohm resistor may be connected in series with the B minus lead and the drop across this used as a 300 cycle source. A .1 mfd condenser may be connected between one side of the resistor and the external circuit to



Style R-54—Closed

EXCELLO

Radio Consoles

For Beauty and Quality

STYLE R-54 Console is adaptable for radio only or Phonograph-Radio combinations. The Top is hinged and a motor board is provided making for the purchasers' convenience if they desire to make their own Phonograph installation.

Regular phonograph equipment consists of A.C. Motor, Electric pickup, Volume control, Phono-Radio switch, Radio adapter, automatic shut-off, etc.

A descriptive bulletin of this and other new styles sent free on request

EXCELLO PRODUCTS CORP.

4820-28 West 16th St.

Cicero, Illinois

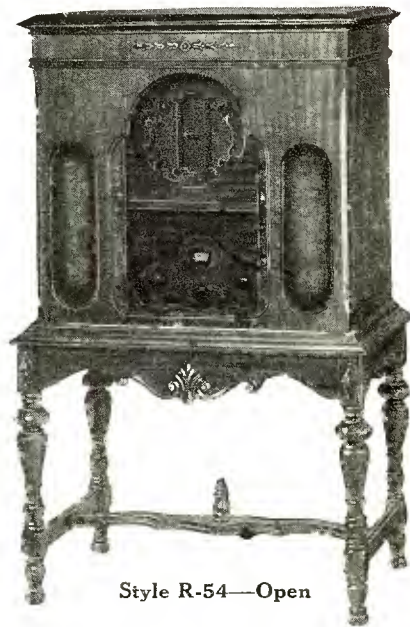

Style R-54—Open

Attention: Radio Manufacturers

We are equipped to handle every type of

COIL WINDING

Send Us Samples of Your Coils or Submit Specifications and
We Will Be Glad to Quote on Any Quantity

We Can Reduce Your Coil Winding Costs!

METAL STAMPING

Let us produce your metal stampings more efficiently and at lower cost. Our battery of modern presses can handle your requirements no matter how large or small. Send samples or specifications for quotation.

Lundquist Tool & Manufacturing Company

143 Green Street

Worcester, Mass.

FREE!

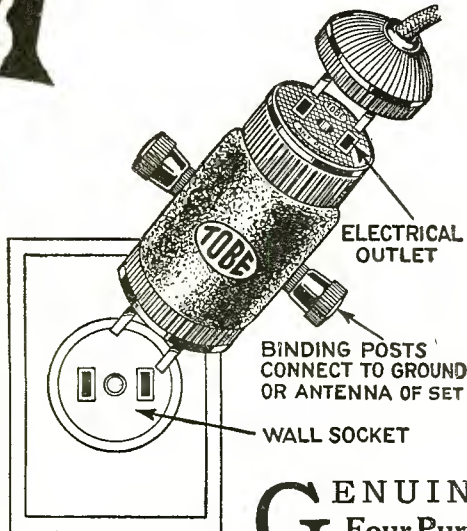

GENUINE Tobe G Four Purpose Light Socket Aerial

FREE with one year's subscription to **Citizens Radio Call Book—Radio's Greatest Magazine.**

The Tobe Socket Aerial solves many aerial problems and does many things—just put plug in your electric light socket and hook your radio set to one side, your ground to the other and you still have your electric outlet.

Static minimized—construction of plug prevents excessive pickup of static—increased selectivity—improves tone quality. Tuning is sharpened—your set will tune much more sharply when you use a Tobe Aerial, than when you use an outside aerial. **Each aerial guaranteed for two years, unconditionally.** Full instructions showing many combinations accompany each aerial.

Send This Coupon Today!

CITIZENS RADIO CALL BOOK MAGAZINE
508 So. Dearborn Street, Chicago, Ill.

Here is my \$1.75 (Foreign \$2.00) for which please send me a Tobe Four Purpose Light Socket Aerial **FREE** and enter my subscription for the Citizens Radio Call Book Magazine for one year starting with the

January March September November issue

Name.....

Address.....

City..... State.....

isolate the d. c. plate circuit. The 227 r. f. tube may be removed to conserve B battery current.

If the audio oscillator is to be used across the audio amplifier in the receiver, the B negative lead of the receiver to be connected to the B minus terminal of the unit and the positive clip of the unit to be connected to the detector plate lead of the receiver. The set B supply then operates the a. f. oscillator. To provide a modulated radio frequency source, both 227 tubes should be used. The unit may then be coupled to another receiver as described above.

When the unit is used as a modulated oscillator for receiver testing it should be loosely coupled to the receiver under test. If good tubes, battery and a good speaker are used and no signal is heard in the speaker when the oscillator is turned over the whole range, that indicates that the set is dead. The unit may then be used as an audio frequency oscillator to test the audio frequency amplifier. By connecting it successively to the primaries of the first and second stage audio frequency transformers, the trouble may be determined.

Once the audio amplifier is known to be working properly, the unit should be used as a modulated oscillator for locating trouble in the radio frequency end. Ground one end of the coupling coil and run an insulated lead, in series with a .00015 mfd condenser, from the other coupling coil terminal to the plate of the radio frequency tube preceding the detector. Tune the oscillator over the whole range until the signal is received. If no signal is heard, the trouble is in the detector. By connecting this lead successively to the plate terminals of the radio frequency stages near the antenna stage, the stage in which the trouble exists may be located. A slight readjustment of the oscillator condenser may be necessary to give maximum signal strength.

Official Parts List

Parts required for the construction of the modulated oscillator as described previous are shown below:

- 1 Potter .00025 mfd fixed condenser
- 1 Potter .25 mfd bypass condenser
- 6 X-L binding posts
- 1 Durham 25,000 ohm powerohm
- 1 Amsco resistor mounting
- 1 Formica 8x8½x3/16-inch sub-panel
- 1 Silver-Marshall 251 output transformer
- 1 Silver-Marshall 320R .00035 mfd variable condenser
- 2 Silver-Marshall 631-A aluminum shields
- 1 Silver-Marshall 550 coil socket
- 1 Silver-Marshall 111-A coil
- 1 Silver-Marshall 275 r. f. choke coil
- 2 Silver-Marshall five-prong sockets
- 1 Kurz-Kasch 4-inch dial
- 1 Pkg. Kester radio solder
- 1 Pkg. Corwico Braidite hook-up wire

The Hammarlund-Roberts "Hi-Q" 29 Model Is Operated from A. C. Line

(Continued from page 72)

the plate leads, which are also short. By placing these tubes between the cans, the can sides are used also as electrostatic tube shields, effectively preventing coupling between tube elements in other parts of the circuit. This arrangement provides minimum coupling between output and input circuits, which is extremely important.

Two Stage A. F. Amplification

The audio frequency amplifier is of the conventional type, using two stages of transformer coupled amplification. The a. f. transformers used have a flat frequency factor over the usual audio frequency range. A radio frequency choke coil is placed between the plate of the detector tube and the first a. f. transformer to prevent any stray r. f. voltages from getting into the audio amplifier. A 171-A type tube is recommended for use in the last stage, although other types may be used if suitable A, B and C voltages are available.

Tell 'Em You Saw It in the Citizens Radio Call Book Magazine and Scientific Digest

Use HAMMARLUND Coils and Condensers For Better Short-Wave Results

Every experimenter with Short-Wave radio reception knows the importance of careful design and precise workmanship in the parts he uses.

Dealing with very high frequencies, problems are presented which do not ordinarily occur when working in the regular broadcast range.

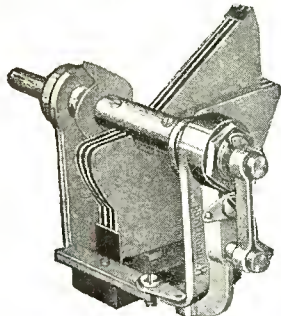

**Short-Wave
CONDENSERS**

Hammarlund Short-Wave Condensers have soldered brass plates with tie-bars; minimum dielectric; aluminum alloy frame; non-shorting bronze pigtail; adjustable ball and cone bearings and a full-floating removable rotor shaft. Available in .0001 mfd., .00014 mfd., and .00025 mfd. sizes—for either the "Mid-line" or "SFL" tuning curve. \$4.75 and \$5.00.

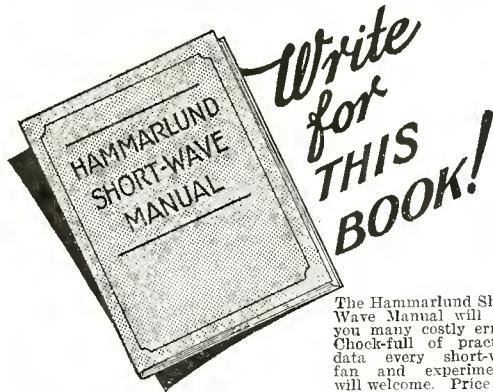

*Write for
THIS
BOOK!*

The Hammarlund Short-Wave Manual will save you many costly errors. Chock-full of practical data every short-wave fan and experimenter will welcome. Price 10c.

The HAMMARLUND Two-Tube Short-Wave Adapter combines a stage of screen-grid R.F. Amplification ahead of a remarkably efficient regenerative detector, giving the highest sensitivity with perfect stabilization.

The Kit is supplied complete, ready to assemble, with panel, base-board and all parts, including the new type Hammarlund Drum Dial and Adapter Plug for instant attachment to any broadcast receiver. Price complete, \$35.00.

It is in the short-wave bands that the real quality of equipment is the most evident.

Hammarlund's long experience and reputation in the radio, telephone and telegraphic fields is your guarantee of better short-wave results with Hammarlund Precision Products.

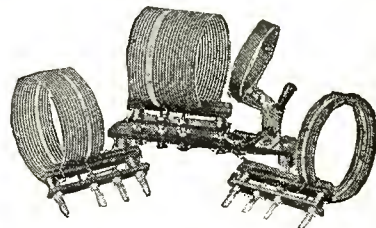

**Plug-In Short-Wave
COIL SETS**

Hammarlund Short-Wave Plug-In Coils are space-wound and supported by a thin film of strong, efficient dielectric material. Widely spaced plug-in terminals. The adjustable primary is integral with the base. Base and coils for the 20, 40 and 80 meter bands, \$10.00. Base only, \$3.00. Coils for 20, 40 and 80 bands, \$2.50. Coil for 120 meter band, \$3.00. Details of these and other Hammarlund Short-Wave Products sent on request.

For Better Radio
Hammarlund
PRECISION
PRODUCTS
HAMMARLUND MANUFACTURING CO.
424-438 W. 33rd Street, New York



AUDIO FREQUENCY TRANSFORMERS AND RADIO PRODUCTS

get the most out of push-pull power amplifiers

Push-pull power amplifiers for dynamic speakers give best results with Ferranti Transformers. AF3 and AF3c for large baffles. AF5 and AF5c for small baffles. Use output transformer OP4CC for Magnavox, Jensen and Wright De Coster. OP8c for Peerless dynamic and all magnetic speakers.

Write for details of the new Ferranti Push-pull licensed power amplifiers.
1929 Ferranti Year Book will be mailed upon receipt of 15c in coin.

FERRANTI, LTD.
Hollinwood
England

FERRANTI, INC.
130 West 42nd St.
New York, N. Y.

FERRANTI ELECTRIC
LIMITED
Toronto, Canada

FROST

Frost Radio Volume Control with AC Switch

A mighty handy and convenient unit for use with phonographic electric pick-up, providing complete control of volume, and an integrally-mounted A. C. Switch controlled by same knob. Switch is approved toggle type guaranteed to carry 250 volts at 3 amperes, and is passed by Underwriters' Laboratories. Our well known Volume Control needs no introduction to readers of the Call Book. It affords perfectly smooth yet continuously variable adjustment of resistance. Roller contact arm eliminates wear. 5,000, 10,000, 25,000, 200,000 and 500,000 ohms. Prices: \$2.75 and \$3.00.



Frost Radio Microphones

We have specialized in the manufacture of high grade telephone equipment for the last third of a century, and in Frost-Radio Microphones we offer the perfected result of our long experience. Solid back, carbon button type. Extremely sensitive, reproducing voice and music with true fidelity. If you want a good mike for short wave telephony or public address work, or for use in making your own announcements with a regular receiving set, you should order one of these Frost-Radio Microphones.

- No. 155 Hand Microphone\$6.00
- No. 159 Desk Microphone 8.75
- No. 157 Pony Arm Microphone..... 4.50

Mail Coupon for Catalog

HERBERT H. FROST, Inc.
ELKHART, INDIANA
Chicago San Francisco

RADIO

HERBERT H. FROST, Inc.
160 N. La Salle St., Chicago
Send me by return mail your catalog of Frost Parts

Name.....
Street Address.....
City.....
State.....

100% Voltage Control PLUS 5 Exclusive Features

1. Double Socket Outlet for A. C. Set and Dynamic Speaker or for A and B Eliminators.
2. Antenna and ground connections.
3. Line Switch.
4. Fuse protection of entire set.
5. Perfect Link between your Set and light socket.

X-L LINK

Eliminates all irregularity in line voltage—the bane of A. C. reception. With the X-L Link your tubes last full life and give maximum service because they are protected from the destructive effect of high voltage fluctuations which weaken or burn out the filament. Reception is smooth and clear without strain or distortion.

No complicated connections—one wire operates everything including ground and antenna. Perfect, unflinching control of line voltage surges that gives you full reception value. Install an X-L Link and note the difference in tube performance.

At your dealer or postpaid on receipt of price.

Write for FREE folder.

X-L RADIO LABORATORIES

Also Manufacturers of X-L Variodensers and Push-Posts

Department G 1224 Belmont Ave., CHICAGO



X-L Link List Price \$5.75

A, B and C Supply

The A, B and C power supply for the Hi-Q 29 Master a. e. model was constructed on a wooden baseboard 8x13x½ inch thick. The layout of the parts is shown photographically in Fig. 6, while Fig. 7 is a graphic diagram by which a novice or layman may wire up the job. The terminals of the power supply are brought out to a row of Fahnestock clips arranged around one edge of the baseboard. These clips are secured to the baseboard by ⅝ inch machine screws inserted in holes in the base and screwed into the Fahnestock clips. The holes are drilled ⅞ inch apart on a line a half inch in from the edge of the base. One of the soldering lugs from the foundation unit is placed under each clip as it is screwed to the base. Transformers, filter condenser and Truvolt resistor are secured to the base by ½ inch round head wood screws. The socket is secured by two 1 inch screws.

The wiring of the power supply is clearly indicated in the graphic diagram in Fig. 7 and may also be seen in the schematic diagram, Fig. 4.

A very neat job of connecting the Yaxley 12-wire cable to the Fahnestock clips may be accomplished by cutting each wire ⅞ inch shorter than the next, starting with the white, then the brown, then the green, slate, blue, etc. After removing about ½ inch of the insulation from the ends of the wire, bind them with electrician tape in the manner shown in the photograph of the completed unit, Fig. 6.

Arcturus tubes are used in the Hi-Q 29 design, these operating from a filament or heater potential of 15 volts and consuming a current of .35 amperes. Due to this low heater current, these tubes are operated in multiple exactly as direct current tubes are and can be wired with the conventional hook-up wire. Extra heavy bus leads are not necessary.

A 15 volt heater potential was chosen after research demonstrated that the hum factor of an a. c. tube could still be further reduced by the reduction of the electromagnetic field around the heater, which decreases with the heater current, while taking advantage of the cathode shielding effect of the electrostatic shield, which increases in proportion with the heater voltage.

Tubes required for use in the Master model described in the accompanying article are two Arcturus No. 22 shield grid tubes, one Arcturus No. 46 detector tube, one Arcturus No. 48 amplifier tube, one 171-A type tube.

The rectifier used in the a. e. model is the well known Raytheon BH tube, which is of the full wave gaseous type and furnishes suitable output voltage required for the receiver.

The use of a power tube such as 171, 210 or 250 in the output stage of a good receiver is very desirable if full advantage is to be taken of the truly remarkable reproduction possibilities of the better type cones and dynamic speakers. For several reasons the 171 power tube is ideal for home use and is, therefore, specified as standard in the output stage of all the Hi-Q models. The output impedance is especially suitable for use with most of the highest class speakers and the output power is generally ample for the volume requirements of the average home. In addition, this satisfactory operation can be secured without excessively high plate voltage. Also it is the only one of the three power tubes above mentioned which can be operated economically with batteries.

Official Parts List

- Parts used in the building of this receiver are shown below:
- 5 Hammarlund No. ML-17 .00035 mfd Midline condensers
 - 1 Hammarlund No. Hi-Q 29 coil set
 - 2 Hammarlund No. SDW know-control drum dials (walnut)
 - 3 Hammarlund No. RFC-85 radio frequency chokes
 - 6 Benjamin Cle-Ra-Tone sockets No. 9040
 - 1 Sangamo .00025 mfd fixed mica condenser
 - 1 Sangamo .001 mfd fixed mica condenser
 - 1 Carter No. 11 Hi-Pot potentiometer, 100,000 ohms
 - 2 Thordarson No. R-300 audio transformers
 - 1 Thordarson No. R-196 choke coil
 - 1 Thordarson No. R-171 power compact

NOT EVERY VOLTAGE CONTROLLER IS A RESISTOVOLT

“RESISTOVOLT”

Automatic voltage controller—Protects A.C. tubes from blowing or burning out by checking the excess voltage prevalent on all house current. First in the field—first in volume sales—miles ahead in mechanical features. Entirely automatic, entirely air-cooled, entirely metal in design. Consumes no current.

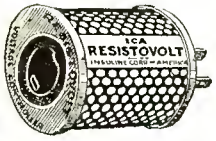

\$1.75
at All Dealers

Trade Mark Reg. U. S. Pat. Off.

Insist on the Genuine. Accept no Substitute. Look for the Trade Mark “RESISTOVOLT.”

Write for complete catalogue of radio products and television sets, kits and parts.

If dealer cannot supply you, remit cost to manufacturer. Shipped postpaid or sent C. O. D. on order.

INSULINE CORP OF AMERICA
78-80 Cortland St., New York City

“ANTENNAVOLT”

combination of Resistovolt and light socket antenna—all the features of a socket aerial, minimizes static, sharpens tuning, improves reception, PLUS Resistovolt voltage control protection. ANTENNAVOLT taps for antenna use the hundreds of feet of all-directional wiring installed in the electric wiring system of your home.



\$2.25
at All Dealers

Breaks All Records MAGNAFORMER Gets Iceland

THE Most Powerful—Greatest Distance Getter—Most Selective and Sweetest Toned Super ever designed, is described on pages 2, 76, 77, 122 and 124 of Spring edition of Citizens Call Book—the NEW 10-tube Super-powerful Shield Grid Magnaformer AC-29, with self-contained, complete Power Supply; Phonograph Pick-up; Long and Short Wave Oscillators; Loop or Straight Wire; Outside or Inside Antenna; Dynamic or Magnetic Speaker; AC Shield Grid or all 227 Tubes.

ON this job KFI is a local in New York—WEAF is a local in Los Angeles. Send AT ONCE for FREE 8 page 12½x37" pink, part-to-part and wire-to-wire, X-Ray Diagrams and Schematic Drawings showing NEW Volume Control and full and complete wiring instructions and reception verifications of Japan, China, Australia, New Zealand, Argentine, Ireland, England—and—the World's Record Breaker—ICELAND, 10,000 miles away. Write Name on Post Card. Mail at once to

RADIART LABORATORIES 1021 Association Bldg., CHICAGO, ILLINOIS.

Wholesale Prices

Here you will find a new up-to-date stock of kits, parts, accessories and sets—everything you want in radio. Write for Catalog “C-3,” quoting special dealers’ wholesale prices.

Allied Radio CORPORATION

711 W. LAKE STREET, CHICAGO

THE SET BUILDERS STAND BY!

FOR FIFTEEN YEARS radio experimenters have used Formica panels, tubing and rod for insulating parts in the sets they have built.

High quality, wide distribution and easy accessibility have made the material the most popular on the market for the amateur’s purposes.

Ask your dealer for FORMICA when you buy

The FORMICA INSULATION COMPANY

4666 Spring Grove Avenue
Cincinnati, Ohio



Travel for “UNCLE SAM”



RAILWAY POSTAL CLERKS

TRAVEL—SEE YOUR COUNTRY

\$1900 to \$2700 a Year

Many Other Government Jobs

MEN—WOMEN 18 OR OVER

Short Hours—Pleasant Work—Rapid Advancement—
Long Vacation With Pay

Mail Coupon Now. Act at once. DO IT TODAY.
You May Forget Tomorrow

----- CUT HERE -----

FRANKLIN INSTITUTE, Dept. P187, Rochester, N. Y.

Rush to me entirely free of charge: (1) A full description of the position checked below: (2) Free copy of illustrated book, “How to get a U. S. Government Job.” (3) A list of many U. S. Government Jobs now obtainable.

..... Railway Postal Clerk, \$1900-2700 City Mail Carrier - - \$1700-\$2100
..... Post Office Clerk - - \$1700-\$2300 General Clerk - - - - \$1260-\$2100
..... Prohibition Agent - - \$2300-\$2800 Rural Carrier - - - - \$2100-\$3300

Name.....

Address.....

Use this Coupon before you mislay it. WRITE OR PRINT PLAINLY.

Raytheon



BH

The Long Life Rectifying Tube

Replace the old rectifying tube in your "B" Eliminator with a new Raytheon BH as soon as you notice a falling-off in the quality and range of your reception. Thus you will maintain quietness, clarity, volume and distance.

Over 100 makes of "B" Eliminators take only this standard tube—125 m. a.; 300 volts.

List Price \$4.50

RAYTHEON MANUFACTURING CO.
CAMBRIDGE, MASS.

BENJAMIN

Cle-Ra-Tone Radio Sockets

Spring supported, shock absorbing.

Y-Type, Green Top, for 5 Prong AC Tubes: For mounting on top of panel, \$1.00; for direct attachment to panel, 75c.

Red Top, for Standard UX Type Tubes: For mounting on top of panel, 75c; for direct attachment to panel, 50c.

At All Radio and Electrical Dealers and Jobbers
BENJAMIN ELECTRIC MFG. COMPANY
120-128 South Sangamon Street
New York Chicago San Francisco

Send for WESTERN RADIO'S Latest 1929 Catalog

THE New 1929 Catalog is crammed full of the FINEST, NEWEST, Nationally known A.C. sets, consoles, cabinets, dynamic speakers, kits, eliminators and accessories at Lowest Prices. Largest stock of radio parts. Prompt delivery. Write for our Free catalog.

WESTERN RADIO MFG. CO.
128 W. Lake St., Dept. CB-3, CHICAGO



"The Big Friendly Radio House"

- 1 Thordarson No. T-2610 filament transformer, 15 volt
- 6 Parvult .5 mfd series 200 bypass condensers
- 1 Parvult 4 mfd series 200 bypass condenser
- 1 Parvult 3 mfd bypass block
- 1 Parvult 1 mfd series 200 filter condenser
- 1 Parvult 2 mfd series 200 filter condenser
- 1 Parvult 4 mfd series 200 filter condenser
- 1 Parvult 2 mfd series 400 filter condenser
- 1 Durham metallized resistor, 1½ megohms
- 2 Durham metallized resistors, ¼ megohm
- 1 Yaxley No. 612 cable connector and cable
- 1 Pair Yaxley No. 422 insulated phone tip jacks
- 1 Electrad Truvolt Hi-Q 29 type resistor
- 2 Eby engraved binding posts
- 1 Hi-Q 29 Master Foundation Unit containing drilled and engraved panel, three complete aluminum shields, drilled steel chassis, shafts, binding post strips, Fahnestock clips, fixed resistance units, resistor mounts, brackets, clips, wire, screws, nuts, washers and all special hardware required to complete receiver

Service Man May Test Rectifier Tubes With This Simple Outfit

(Continued from page 81)

With the tremendously large number of factory built receivers, in which the power supplies are a portion of the chassis, there is always a possibility that poor rectifier tubes may cause some difficulty with the sets. As a result the rectifying tube tester described previously should be welcomed by the service man and professional set builder as a method of immediately checking for trouble in a receiver.

Official Parts List

Parts required for the construction of this rectifier tester are:

- 2 B-7.5 Electrad fixed resistances with sliders
- 1 Carter HW11 ohm rheostat
- 2 Frost a. c. switches
- 1 Eby UX socket
- 2 Formica 7x16x3/16 inch panels
- 2 Weston model 301 0-150 milliammeters
- 1 Weston model 301 0-8 voltmeter, d. c.
- 1 Weston model 301 150 d. c. voltmeter
- 2 Eby binding posts
- 1 Package Kester radio solder
- 1 Package Corwico Braidite hook-up wire

Modified Rack and Panel Amplifier Now Available at Low Cost

(Continued from page 76)

former. The output of the 250 tubes is taken through a 248 Universal output choke. The power supply employs one 324 power transformer, a 331 Uni-choke, a 333 dual choke and a 673 condenser bank. Input binding posts are provided for connecting of one record pick-up, or two with their own selector switch, one microphone and the output of a radio set detector tube or another record pick-up if desired. The three-position key switch selects any one of these three inputs for amplification and a tapered potentiometer controls volume and fading from zero to full output. Three sets of loud speaker output connection posts provide three output impedances suited to combinations of one to twelve magnetic or dynamic speaker units for theater, auditorium or stadium use, up to 100 or 150 speakers for apartment, school or hospital use, or up to 1000 headphones for hospitals or other uses.

All parts are solidly attached to the aluminum panel, the rear of which is covered by metal dust covers effectively protecting all apparatus and isolating the a. f. amplifier and power supply

A Pam Brings Out the Best in Any Set

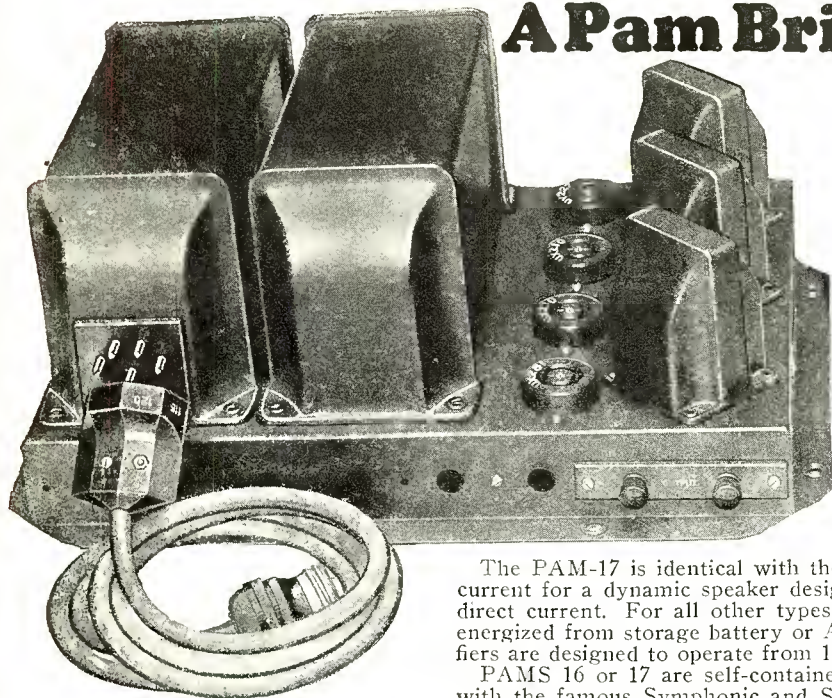

PAM 16 or 17
Price, without tubes,
\$125.00

Main Office:
Canton, Massachusetts

The PAM-17 is identical with the PAM-16 except that it furnishes in addition field current for a dynamic speaker designed to have its field energized by 90 to 165 volts direct current. For all other types of speakers, including dynamic, having their field energized from storage battery or AC 110 volt 60 cycle, use the PAM 16. Both amplifiers are designed to operate from 105 to 120 volts 50 or 60 cycles AC.

PAMS 16 or 17 are self-contained, rugged, all electric, two stage, audio amplifiers, with the famous Symphonic and Symphonic Push Pull Transformers. They provide compensation for line voltage variation and require one UY-227, and two UX-210s and one UX 281 tubes. Designed to meet AIEE Standards and Underwriters' Requirements. No output device between PAM and speaker is required. Dimensions 15 x 11½ x 7½". Net weight 32 lbs.

Samson Electric Co.

Factories:
Canton and Watertown, Mass.

Aerial and Ground Loud Speaker Power Pack Battery 110-Volt A. C. Connections



Single Plates and in Gang in Many Combinations

Brushed Brass and Bakelite

Yaxley Radio Convenience Outlets bring a new convenience and comfort to the enjoyment of radio. They provide a neat, workmanlike method of completing radio connections and remove all the unsightly features that mar the radio installation and detract from the good appearance of the modern radio set. With Yaxley Radio Convenience Outlets you plug in the receiver, loud speaker, 110-volt a.c., power pack or batteries just the same as a stand lamp or any other electrical convenience.

Yaxley Radio Convenience Outlets are easy to install. They fit any standard electrical outlet box, or where out-

let box is not available the mounting strap is fastened directly to the plaster lath or studding. Everything required for a complete radio convenience outlet installation may be bought at your local radio store or electrical shop. The wall plates are finished in brushed brass to harmonize with standard electrical plates, or where desired they may be had in rich brown Bakelite.

Ask your local radio or electrical store to show you Yaxley Radio Convenience Outlets. In the meantime, write to us direct for illustrated bulletin.

YAXLEY GUARDIAN HOME BURGLAR ALARM

Install a Yaxley Guardian Home Burglar Alarm and protect the family and the contents of the home from the burglar, sneak thief and porch climber. Self contained, complete with instructions for installation.

We believe there is a great opportunity for set builders and service men to build up a nice business installing burglar alarms in the home

and in fur shops, jewelry, dry goods and drug stores, garages, service stations and similar places in every community. In suburban and rural sections many handy men are making good money installing electrical protection in homes, barns, stables and chicken houses. Write us, giving the name of your jobber for special introductory offer and our plan for starting you in this business.

YAXLEY MFG. COMPANY, Dept. C., 9 South Clinton Street, Chicago, Ill.

"Details Make Perfection But Perfection is No Detail"

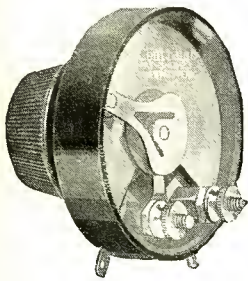

Centrallab Modulator
A typical example of CRL superiority of design. Rocking Disc Contact, Constant Resistance, Durable Construction, Perfect Theoretical and Mechanical Design. Made in any resistance and any style for use as Volume Control in critical and non-critical circuits.

List Price\$2.00

Centralab resistances are details that make for perfect reception.

Every time you tune in your radio set you must adjust the voltage and volume controls and then reset them for every different station or condition of reception. This important phase of operation of your radio set must not be neglected.

Centralab Voltage and Volume Controls have been giving satisfaction to the entire radio industry virtually since the beginning of radio. In them are embodied the improvements in theory and design developed by our engineering staff during these years of progress. They are undoubtedly the finest Variable Resistances that can be had today. It costs no more to equip your set with Centralab Resistances than with others and you are insuring perpetual freedom from the common irritation of noisy, faulty, volume and voltage controls.



CENTRAL RADIO LABORATORIES
12 Keefe Avenue Milwaukee, Wisconsin

SHORT WAVE Reception at Its Best Is Assured with a SUBMARINER

because this instrument can be attached to any receiving set, either AC or DC, without any wiring changes. The Submariner is the pioneer short wave adapter. It has been sold in all parts of the world since June, 1926, and naturally has all the latest improvements. The Submariner has been manufactured completely shielded for over one year. It has been using tuning dial with 32 to 1 ratio, for about two years. A quality product at the lowest price.

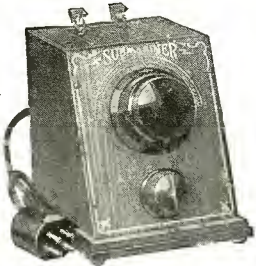

All live radio dealers carry these in stock and are fully protected. Get yours from him today.

SUMMER RECEPTION
without static is very practical on short waves. The Submariner is exceptionally quiet in operation.

FOUR MODELS to fit each distinct need. 20 to 65 meters, \$15.00 for DC. \$17.50 for AC. Interchangeable coil model. 10 to 160 meters, \$22.50, AC or DC. No. 4 coil, 160 to 340 meters, \$2.00 additional. If your dealer does not carry, sent postpaid on receipt of price. 60c additional in Canada and most foreign countries. C.O.D. only in U. S. if \$1.00 accompanies the order. **ORDER TODAY.**

J-M-P Manufacturing Co., Inc. 3447 Fond du Lac Ave. MILWAUKEE, WIS.

FREE—RADIO CATALOG 1929 WHOLESALE

Dealers—Set-Builders—Write today for this 1929 Wholesale Catalog containing hundreds of money-saving "specials." Over 2,000 items. Complete lines of Radio Sets, Cabinets, Tubes, A & B Eliminators. Speakers, Parts at prices that mean **BIG SAVINGS!**

COMPLETE TELEVISION SECTION
Latest television equipment, A.C. Sets, Short Wave Receivers, Dynamic Speakers, also listed. Write Now—

BENSON-ALLEN, Inc. 456 South State Street Dept. 36, Chicago, Ill.



The Receiver That's a Year Ahead

That's what you can build with the Vee Screen Grid Kit. Combining to the fullest extent all the advantages of Screen Grid and A.C., it has an undistorted volume heretofore unobtainable

with less than eight or ten tubes. It is 6 tube, loop operated, lamp socket operated—everything included for set and power supply, A, B, and C. Send today for all details.

VEE Products Division

Story & Clark Piano Co., 173 No. Michigan Blvd., Chicago, Illinois

sections. All metal parts are furnished in crystalline black with tube positions and control legends plainly engraved on the panel. All binding posts are on bakelite terminal strips on the rear of the control panel. The 690 amplifier is equipped with mounting holes so that if desired it may be permanently mounted in a standard S-M PA-1A rack or it may be attached to brackets for upright or side mounting in projection room, principal's office, cabinet or other convenient place. It is fully portable, for truck or automobile installation.

The completed amplifier is shown in the photograph in Fig. 1, while the schematic circuit in Fig. 2 discloses all of the electrical details of the 690.

B Eliminator, A Battery Charger and Relay for 110 Volt D. C.

(Continued from page 82)

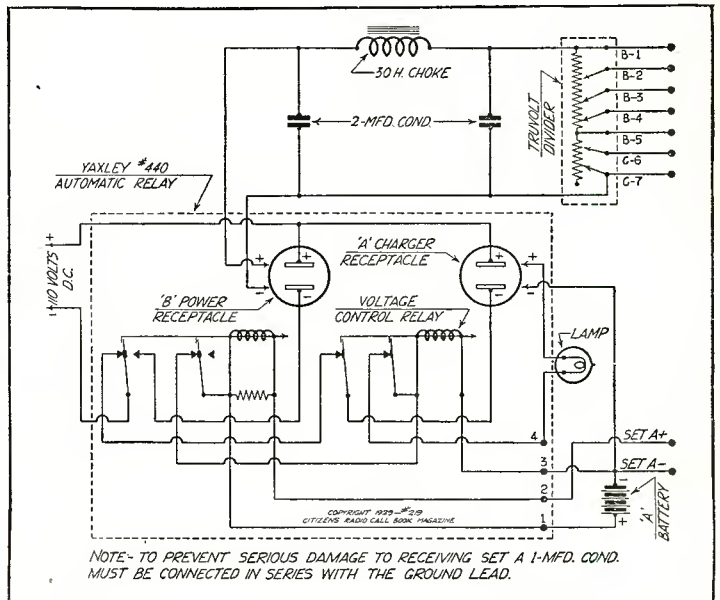

Fig. 2. The schematic circuit involved in the unit described in this article is shown in the illustration above

relay is set at the factory to kick off at a safe value when reached. Condenser in Ground Lead

To prevent serious damage to the receiving set, it is quite necessary that a 1 mfd condenser be connected in series with the ground lead. The reason for this precautionary measure is the fact that if

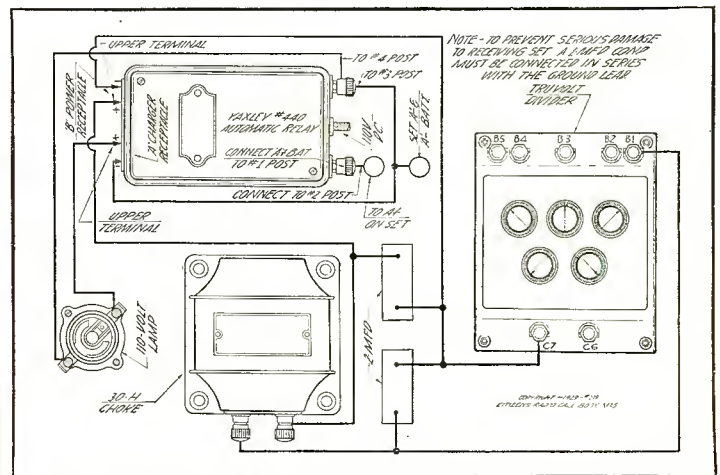

Fig. 3. This graphic diagram shows the manner in which the unit may be laid out and wired. Probably a better idea of the actual layout may be gained by referring to the photograph shown in Fig. 1

that were not done and the negative side of the set were grounded. if the positive side of the line were grounded, there would be trouble. In most of the 110 volt circuits, it will be found that in most locations the positive is grounded and in others the negative is grounded. This does not interfere with the operation of the receiving set, although it would interfere very disastrously if the 1 mfd condenser in series with the ground lead were left off.

The connections for the 22, 45 and 67½ volt are made to the binding posts on the Truvolt divider, which post may be seen in the illustration shown in Fig. 1.

Official Parts List

Parts required for the unit described in the foregoing article are shown below:

- 2 105 Potter 2 mfd filter condensers
- 1 380 Samson 30 henry audio frequency choke
- 1 Electrad Truvolt divider
- 1 Formica 8½x9x3/16-inch black sub-panel
- 2 Eby binding posts
- 1 Sub-panel bracket
- 1 440 Yaxley automatic relay
- 1 Lamp socket
- 1 Pkg. Kester radio solder

Lamp Bank Serves as Resistance in Simple A Battery Eliminator

(Continued from page 83)

on the resistance will give 67 and 45 volts. The bottom terminal, of course, is the B negative. In the event that it is desired to use more than 90 volts on the last stage of the receiver, a separate B battery of 45 or 90 volts may be placed in series with the plus 90 volt terminal of the eliminator, so as to give a total voltage of 135 or 180 volts. Under these conditions, the negative terminal of the added battery will go to the plus 90 volt terminal of the eliminator, while the positive terminal of the 45 volt or 90 volt section will go to the plate of the power tube.

In connection with the B eliminator, it should also be noted that the unit should not be operated without a fixed condenser in the lead from the set binding post to ground, for the same reason as given previously for the operation of the A eliminator.

A Eliminator Parts

Parts required for the construction of the A eliminator are:

- 1 Yaxley 100 ohm potentiometer
- 1 Weston 0-10 d. c. voltmeter
- 4 Eby binding posts
- 8 Lamp sockets
- 1 Yaxley 110 volt line switch
- 1 Package Corwico hookup wire
- 1 Package Kester radio solder

B Eliminator Parts

Parts for the B eliminator are shown below:

- 1 Sansom 30 henry choke
- 2 Potter 2 mfd bypass condensers
- 1 Electrad 10,000 ohm fixed resistance with two sliders
- 4 Eby binding posts

Wiring of Homes for Radio Is Source of Profit to Service Men

(Continued from page 75)

Good Apparatus

With the progress that has been made in amplifier design, in the past two years, it can be safely said that quality reproduction has been achieved. It can also be definitely stated that the amplifier systems offered for this particular work are so well designed and fabricated, no one need anticipate any operating trouble. About the only likelihood for encountering any difficulty

ASTON CABINETS

For Beauty and Quality

Model No. 225

RADIO and PHONOGRAPH

A fine example of perfection in every detail, full information sent on request.

Dealers and Set Builders Write for Our New 1929 Catalog

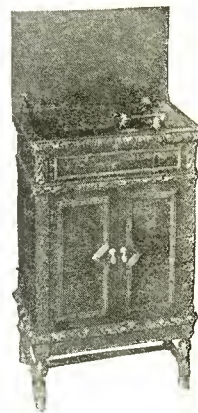

It will give you full details of this beautiful cabinet, as well as description of many other pleasing ASTON models. Our attractive discounts will interest you.

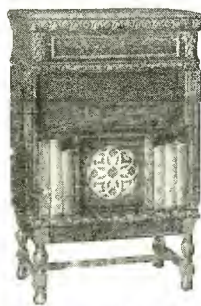

ASTON
Cabinet Manufacturers
 1223-1229 W. Lake St.
 Chicago, Illinois
Distinctive Originality in Design of High Grade Radio Cabinets

Improves Radio Reception and Increases life of tubes

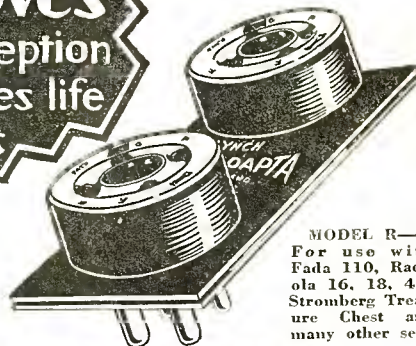

The NEW **LYNCH**

MODEL R—
 For use with Fada 110, Radiola 16, 18, 41; Stromberg Treasure Chest and many other sets.

TUBADAPTA

eliminates the blasts and unnatural noises of full volume reception. Output of receiver is practically doubled, with absolutely no distortion. A simple means is provided for using

2 Tubes in Parallel

in last audio socket. This reduces the impedance in the power stage, resulting in much better reproduction of the ordinarily "hard-to-get" low notes. Dynamic speakers give amazing results.

It will pay you to send for 40-Page Free Booklet, "Resistance, The 'Control Valve' of Radio"

ARTHUR H. LYNCH, Inc.
 1775 Broadway (at 57th St.) New York



"You Can Forget the Condensers—If They Are DUBILIERS"

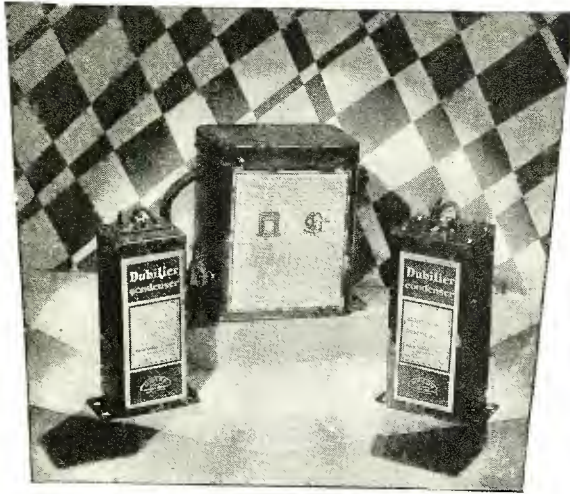

cr-r-rack ~ cr-r-rash!

**.Eliminate Interference
with one of these Devices**

THESSE scientifically designed interference eliminators make your set operate as quietly as with batteries.

Types 1 (\$5.00) and 2 (\$7.50) are of condenser design; the No. 2 unit has double the No. 1 capacity.

Type 3 uses a specially designed filter net work. This unit because of its highly developed

choke coil and shunt condenser system has wonderfully fine filter characteristics. Price \$15.00.

Dubilier Light Socket Aerial
"A Moulded Bakelite Product"

Plug it into any light socket—eliminates acrials and lightning arrestors. Works on any set. No current used. At your dealer or from us direct. Price \$1.50.

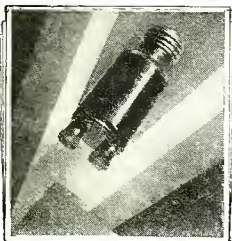

Write to Dept. 62  for Free Catalog

Dubilier
CONDENSER CORP.
10 E. 43rd Street, New York City

will be in the wiring connected with the input, but if the suggestions regarding the use of lead sheath cable are followed, no trouble may be expected. Of course, there are occasions when the location of a speaker with respect to a microphone might be the cause of audio feed back, but as most of the installations under consideration cover a fairly large area, the difficulty from feed back need not be emphasized. In smaller locations, when the loud speaker and the microphone are located within a few feet of each other, trouble may be anticipated.

Those contemplating the use of amplifier systems for radio, phonograph or speech work may communicate with this department, if they desire, and advise us of their needs. We will also be interested in hearing from operators of existing installations, who may wish to pass on to their co-workers any experiences they have derived from such installations.

Optional Connections for Use with Muter Dynamic Speakers

(Continued from page 85)

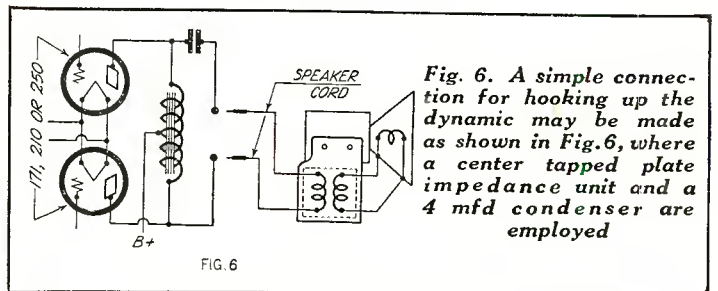

Fig. 6. A simple connection for hooking up the dynamic may be made as shown in Fig. 6, where a center tapped plate impedance unit and a 4 mfd condenser are employed

table models and the Console cabinet models, the baffle is automatically provided. However, when the unit only is to be used, it must be mounted with a suitable baffleboard.

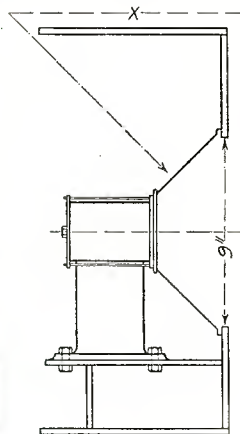

FIG. 7

Fig. 7. In order to obtain satisfactory performance all dynamic speakers must be used with a suitable baffleboard. In the table and cabinet models the baffle is automatically provided. However, when the unit only is to be used, a baffleboard must be arranged. A good baffleboard should be at least 2 feet square and made of wood or wallboard not less than 3/8 inch thick. It should be of non-resonant material, so that it will not vibrate and radiate sound when the unit is being operated. The opening in the baffleboard must be 9 inches in diameter. The unit should be mounted behind the baffleboard with the felt ring on the front of the cone housing pressed evenly and tightly against the board. The unit should be held in this position by screwing down the base to a shelf provided for that purpose, as illustrated in Fig. 7. It is neither necessary nor desirable to screw the housing itself to the baffleboard. The distance of the line X shown in the drawing should be at least 2 feet

Tips on Baffleboards

Baffleboards should be of non-resonant material so that they will not vibrate and radiate sound when the unit is being operated. The board should be at least 2 feet square and made of wood or wallboard not less than 3/8 inch thick. The opening of the baffleboard must be 9 inches in diameter, in the case of the Muter speaker. The unit should be mounted behind the baffleboard with the felt ring on the front of the cone housing pressed evenly and tightly against the board. The diagram shown in Fig. 7 gives an idea of the manner in which the unit can be held in position. It is not necessary or desirable to screw the cone housing itself to the baffleboard.

When a Muter speaker is installed in a console cabinet, care

CORWICO
Braidite
HOOK UP WIRE
"THE BRAID SLIDES BACK"
CORNISH WIRE Co
30 Church Street New York City

must be taken to insure that it is properly baffled. When the grille opening is larger than 9 inches, a baffleboard with a 9-inch hole should be placed behind the grille and the speaker unit mounted tightly against this. Generally speaker, the larger the baffleboard the better results which may be obtained. In any event, the distance X in Fig. 7 should be at least 2 feet.

Write for Your Copy

Arrangements have been made with the Leslie F. Muter Co., 8440 South Chicago Ave., Chicago, Ill., so that professional set builders and service men desiring a copy of the Muter instructions for installation of their speakers may secure a copy by writing the company at the address given above and mentioning the name of this publication.

Filter for Interference Reduction More Necessary Than Ever

(Continued from page 80)

test are required to withstand this potential for fifteen minutes. Where the filter is designed for operation on a. c., the condenser must be tested on a. c., or if a. c. of the proper potential is not available, then it must be tested on d. c. at twice the testing voltage required for a. c., the time of test being as previously, 15 minutes.

Where an inductive type filter is used, the inductance must be capable of operating continuously without undue heating at the rated carrying capacity of the filter. In the case of the inductive type filter, the potential on which the unit is used is not necessarily critical. Inductive and capacitive filter, however, is critical both as to potential and load.

In general, the capacitive type filter is applicable to all types of electrical apparatus which set up radio disturbances. In a good many instances 100 per cent elimination is secured. In other cases, an inductive type filter would be better, or yet again a combination of the two types is required.

Money in Chasing Noises

After thoroughly looking over the interference problems, it becomes more evident than ever that the service man or professional set builder is the logical individual to trace down and remedy the source of interference. Naturally this will bring up the possibility of making money in the sale of apparatus for the prevention of interference. In some cases service men have been able to make quite a profit by merely carrying around with them two or three filters in their service kits while making coils. In many instances the cause of interference has been readily located and the remedy found in the application of the proper type of filter. The customer has been so gratified in the elimination of the interference that no difficulty is encountered in making a sale.

In order that all service men may be thoroughly acquainted with the problem of running down interference, and that they may learn as quickly as possible the methods of eliminating such interference, we suggest that they write the Tobe-Deutschmann Co. for literature on the subject or asking that copies of the Filterette be sent them regularly.

Practical Television

(Continued from page 98)

additional motor. However, the main point here is that a friction drive is most satisfactory in obtaining and maintaining the necessary driving speed. Some may even prefer to mount the scanning disc on the driving motor, utilizing a suitable resistance for obtaining the necessary speed.

"Now go ahead and tune in station W3XK (46.7 meters) on a short wave receiver or short wave adaptor, and adjust the speed of the scanning disc to 900 r.p.m., which means only that you slide the supporting board holding the driving motor, outward from the scanning disc center until your picture comes in as you

FIVE REASONS

for installing AMPERITE in your radio, any one of which is enough. But the one big reason is that Amperite is the only self-adjusting filament control—the only resistance that automatically stabilizes the ebb and flow of "A" current to your tubes. Its patented principle cannot even be imitated. Don't let outward resemblances mislead you.

Order AMPERITE by name and insure the fine quality of performance your tubes were designed to give.

A type for every tube, A. C. or D. C., \$1.10 with mounting (in U. S. A.) at all dealers.

Radiall Company
50 FRANKLIN ST., NEW YORK
Write Dept. CR3

FREE "Amperite Blue Book" of modern circuits and valuable construction data.

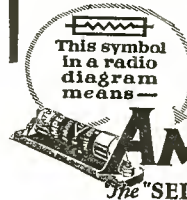

AMPERITE
REG. U. S. PAT. OFF.
The "SELF-ADJUSTING" Rheostat

The ALVON ~ ~ Custom-Built Radio

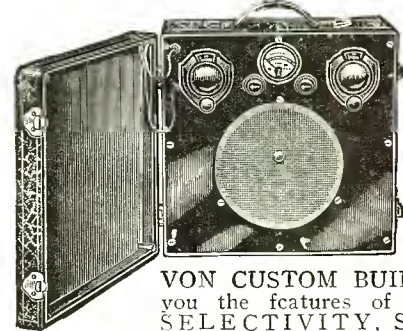

Just the thing for your vacation! With a weight slightly under 30 lbs., fully equipped, dimensions of 13 3/4" high, 14 1/4" wide and 8 7/8" deep, the ALVON

VON CUSTOM BUILT PORTABLE offers you the features of DISTANCE, TONE, SELECTIVITY, SENSITIVITY and CRAFTSMANSHIP, unsurpassed by any commercial receiver on the market.

List Price \$110 Less Batteries and Tubes
Agents desired at once. Write today for special proposition and descriptive literature
ALVON RADIO LABORATORIES
716 West Madison St. Chicago, Illinois

FREE!!

with a year's subscrip- tion to the Citizens Radio Call Book Magazine



The Famous WARD needs no introduction. Heating Elements will not burn out; either A. C. or D. C., 110-115 volts draws 100 watts. Six feet of heater cord, standard 2-piece separable plug, ebony finish handle, brass plated barrel, $\frac{3}{8}$ -in. diamond-shaped tip, temperature 500 degrees maintained, handle remains cool. Handle insulated against possible short. A genuine high-grade electric iron. Lava rock core approved and listed as standard by Underwriters' Laboratories.

**A most useful household article.
Can be used to solder anything
that requires soldering**

Send in the coupon below and receive the iron absolutely free with a year's subscription to the Citizens Radio Call Book Magazine—for only \$1.75. Hurry—this offer is limited—mail coupon today.

**Iron Is Guaranteed by Manufacturer for
One Year—Hurry—This Offer
Is Limited**

Citizens Radio Call Book Magazine
508 So. Dearborn Street, Chicago, Ill.

Here's my \$1.75 (Foreign \$2.00), for which please send me a Ward Electric Soldering Iron free and enter my subscription for the Citizens Radio Call Book Magazine for one year starting with the

Jan. March Sept. Nov. issue.

Name.....

Address.....

City.....State.....

look through the top of the disc at the glowing neon lamp. The latter should preferably be a television neon lamp, although the small "bug lights," obtainable for less than a dollar and intended mainly as night lamps in standard lighting circuits, will work for modest results.

Easy to Synchronize

"It is astonishingly easy to get synchronism by this mechanism, and the layout is so simple that anyone can engage in television experiments.

"Don't use more than two friction discs together, cut from the average thickness of inner tubing, and one thickness is usually best. The disc may chatter a little at starting, but the synchronism is easier held after it is up to speed.

"Personally, I do not recommend a variable resistor in the circuit with the driving motor as a means of obtaining synchronism. I prefer to have the motor run at its natural speed for which it was designed, and obtain synchronism by the friction drive method.

"The neon glow tube should be connected to the output of the amplifier of the set. A B-power unit or B-batteries may be employed. It is well to use a switch, so that the output can be thrown from the neon lamp to the loud-speaker, so as to receive either television signals or broadcast signals for the announcements between pictures. The glowing electrode (cathode) of the neon lamp should face the disc, of course. If it does not, the connections may be reversed.

"While this simple arrangement will get pictures when attached to any good radio set, much better results are obtained if a resistance coupled amplifier is employed.

Non-Oscillating Receiver

"For best results the receiver must be on the point of non-oscillation, or just below the point where oscillations begin. A receiver that will bring in good phone reception will produce good pictures; therefore, the receiver can be adjusted in the usual manner.

"The image received should be in black. In other words, the lamp is continuously lighted until picture signals blink it out to make up the movies in black silhouette on a pink background.

"The amount of light given off is regulated by the C bias on the last or power tube of the amplifier, although the bias must be high enough to permit the incoming picture signals to overcome the plate current, blocking the light given off by the neon lamp. It has been found that a C bias voltage between 12 and 45 volts on the last tube will be sufficient on all types of neon glow tubes.

"To receive pictures, tune in on the Jenkins television station (W3XK) and listen for the announcement. The signals are broadcast on 46.7 meters for an hour every Monday and Wednesday and Friday evenings at 8 o'clock, eastern standard time.

"At first, with an induction or d. c. motor, there will be only black-and-white dots in the picture arca, but when the speed of the scanning disc has been brought into synchronism with the speed of the transmitter, the picture will suddenly appear, as one looks at the neon lamp through the flying holes of the scanning disc. When the transmission of the picture ends, the picture frame on your scanning disc is smooth pink, and you should switch it off and switch on the loud-speaker so as to listen to the announcer.

"If the picture appears upside down, take off the disc and turn it around, other side out. This will make the picture right side up.

Fascinating Study

"Television is a most fascinating study, and anyone with the experimental complex may partake in the present television try-outs. For those who prefer to enjoy television pictures without the experimental feature, there will soon be available the Jenkins Televisor or home television receiver, which will reproduce the Jenkins radio movies in a simple and satisfactory manner so that an entire family circle can partake of the entertainment at one time."

Interesting Methods of Employment for New Foto Electric Cell

(Continued from page 84)

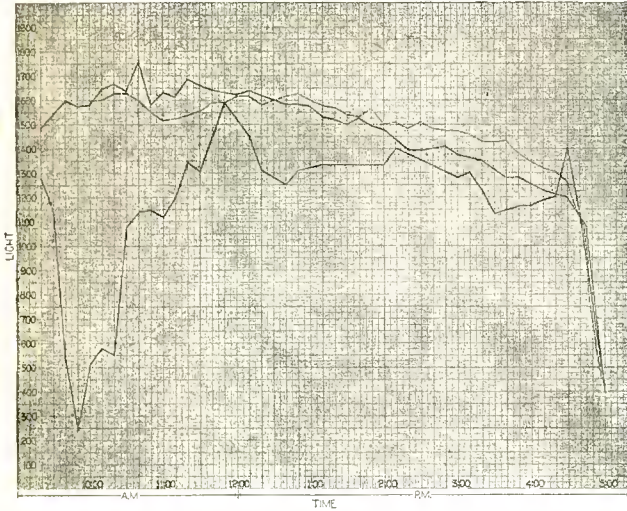

Fig. 4. This graph represents the variations in sunlight and cloudiness, measurements having been made with the Foto Cell

nected to this relay, as illustrated in the wiring diagram. An 0-10 millimeter has been provided in the circuit for adjustment of the plate current which goes to the relay. This has not been placed on the panel of the instrument, inasmuch as it is not necessary to use this millimeter in the circuit continuously and a great saving in cost obtained from using a portable millimeter rather than a permanent installation. The foto electric cell is placed across the grid and the plate of the 226 tube. The foto electric cell may be placed at some point of advantage where the headlights of the car will strike it on the approach to the door, either on the door or hung behind a glass panel in the door, or some other point if it is advantageous.

Operating Adjustments

In the operating adjustments of the instrument, the adjustments should be made either at night when no light is shining on this foto electric cell or in the daytime with a black cloth

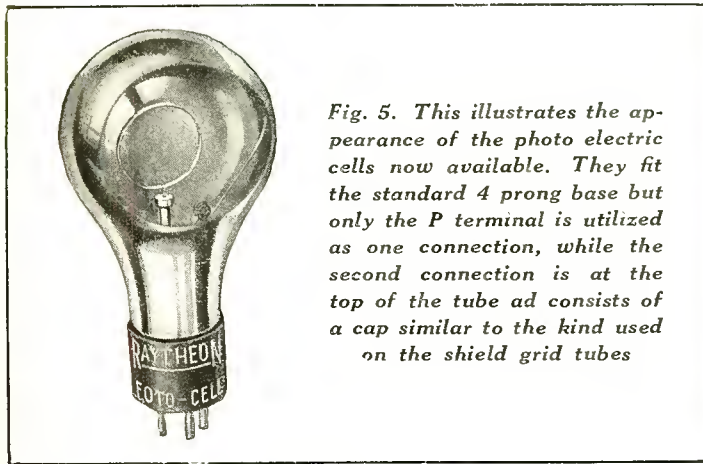
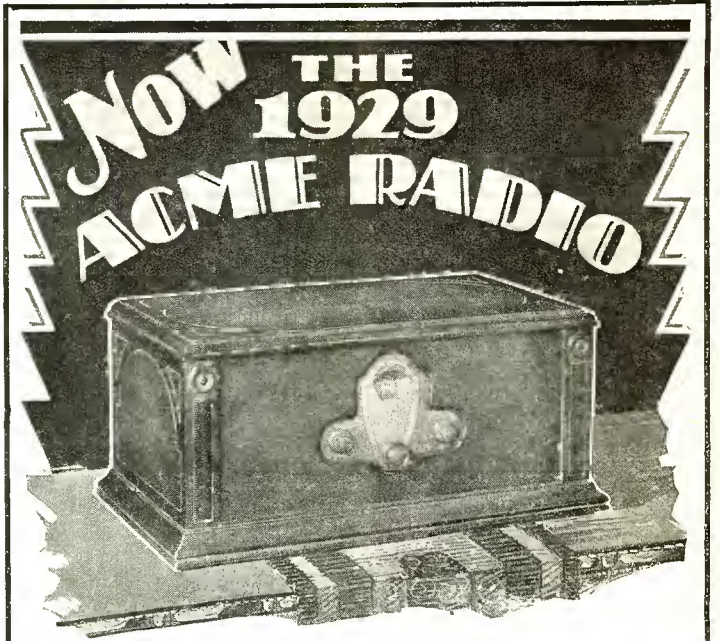

Fig. 5. This illustrates the appearance of the photo electric cells now available. They fit the standard 4 prong base but only the P terminal is utilized as one connection, while the second connection is at the top of the tube and consists of a cap similar to the kind used on the shield grid tubes

thrown over the foto electric cell so that no light can reach the active surface of the cell. The 2000 ohm grid biasing variable resistance should then be adjusted so that a continuous current of approximately 5 milliamperes goes through the milliammeter. Then with the taking off of the hood or the shining of an automobile headlight on the foto electric cell, the current will probably



Model AC-7

The Acme AC-7 is a seven tube receiver, unrivaled for sensitivity, selectivity, power and tone, that will bring in stations "as clearly and distinctly as a bell."

It is housed in an attractive walnut cabinet that is befitting the finest of homes.

Popularly priced at **\$70.00** tubes additional

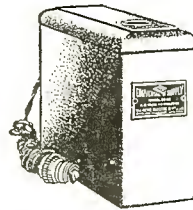

The Acme "B" Power Unit will give you smooth and satisfactory performance.

Type B-280 uses a 280 tube and delivers 180 volts at 40 mills.

Lists **\$22.50** with tube at only **\$1.25** additional

The Acme AC-7 chassis is ideal for combination with all types of console cabinets.

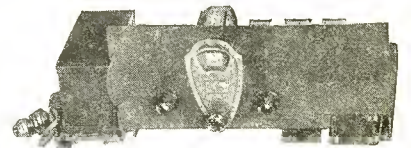

All electric, illuminated single dial control. The chassis is heavy gauge steel finished in crystalline lacquer.



List Price **\$58.00**

Ask Your Nearest Acme Dealer

"Acme Products are known from Coast to Coast"

THE ACME ELECTRIC & MFG. COMPANY
1439 Hamilton Ave. Established 1917 Cleveland, Ohio

Dealers! Write us for information on our 1929 Dealers' Franchise.

Breaks All Records MAGNAFORMER Gets Iceland

THE most Powerful—Greatest Distance Getter—Most Selective and Sweetest Toned Super ever designed, is described on pages 2, 76, 77, 122 and 124 of Spring edition of Citizens Call Book—the NEW 10-tube Super-powerful Shield Grid Magnaformer AC-29, with self-contained complete Power Supply; Phonograph Pick-up; Long and Short Wave Oscillators; Loop or Straight Wire; Outside or Inside Antenna; Dynamic or Magnetic Speaker; AC Shield Grid or all 227 Tubes.

ON this job KFI is a local in New York—WEAF is a local in Los Angeles. Send AT ONCE for FREE 8 page 12½x37" pink, part-to-part and wire-to-wire, X-Ray Diagrams and Schematic Drawings showing NEW Volume Control and full and complete wiring instructions and reception verifications of Japan, China, Australia, New Zealand, Argentine, Ireland, England—and—the World's Record Breaker—ICE-LAND, 10,000 miles away. Write Name on Post Card. Mail at once to

RADIART LABORATORIES

1021 Association Bldg.,
CHICAGO, ILLINOIS

50,000 FEET OF RADIO

50,000 square feet of floor space in a large, modern building devoted exclusively to radio. Tremendous stock of latest kits, parts, accessories and sets in improved designs and styles. Write for Catalog "C-3." Wholesale Prices.

**Allied Radio
CORPORATION**

711 W. LAKE STREET, CHICAGO

FIFTH AVENUE
Near SMITHFIELD

Hotel Henry

IN THE HEART
OF EVERYTHING
WORTHWHILE

SINGLE ROOM \$2.00 & UP
DOUBLE ROOM \$3.00 & UP

Excellent Restaurant
BREAKFAST 40¢ to 75¢ LUNCHEON 85¢
TABLE D'HOTE DINNER \$1.25

Popular Priced
Coffee Shop

HOTEL HENRY

PITTSBURGH

GEORGE S. LEHNER
GENERAL MANAGER

increase in some cases upwards to 15 milliamperes. This will, of course, trip the relay, which in doing that will automatically open the doors. If the foto electric cell is mounted in the glass panel in the rear of the door, the cell will be out of active light as soon as the door begins to open. This will, of course, release the relay and open the switch, which would prevent the automatic repeating of the door action, such as would happen with the majority of automatic door openers on the market at the present time. By attempting various adjustments, with the grid biasing resistance, the current may be varied to such an extent that the foto electric cell may be made sensitive or insensitive as it is desired, or responding to a certain intensity light, which would prevent the doors being opened by stray lights such as automobiles turning around in the street, etc.

No Two Jobs Alike

As no two installations would be identically alike, it is quite impossible to give implicit instructions for the installation and adjustment in this article. However, after a few experiments with this set-up, we feel sure that the professional set builder will be able to install it and secure a perfectly satisfactory operation after a few attempts.

Another use for the foto electric cell, which is perhaps more interesting than usual, is the means of measuring light intensity. It will be noticed in Fig. 4, a graph representing a daylight curve taken over a period of three days between the hours of 9:20 a. m. and 5 p. m., that no two of the three days have the same amount of light at more than two or three instantaneous periods. In the case of the daylight recording device, a slightly different circuit arrangement was used, wherein a balanced bridge output circuit was used in the plate of the tube and a 0-200 microammeter in place of the 0-10 milliammeter. The light intensity figures were figures of .1 microamperes, that is, the top was 2000 tenths or 200 microamperes. It will be noticed on the third day of recording there is a very decided dip the early morning hours. This was due to a slight snow storm, which very greatly diffused the light rays of the sun. It will also be noted that the greatest intensity of light was between the hours of about 10 and 11 a. m. After 12 o'clock noon the light very gradually decreased, until at 5 o'clock it was practically in total darkness. As these measurements were made in January, the days were very short and darkness came rather early. As the days grow longer, the curves will extend further and further into the evening hours until in mid-summer the point of greatest light intensity will gradually go from between 10 and 11 to between 11 and 12 and then between 12 and 1. It is quite possible to calibrate this type of arrangement against the standard foot candlepower meter and, therefore, having a direct leading foot candlepower light intensity meter. This arrangement then could be made into a compact arrangement if so desired for measuring the illumination of factories, etc., or for a small weather bureau for measuring the amount of light intensity during the period of the day, or another interesting experiment might result from measuring the intensity of light at various stages of moonlight, full moon and moon set. There are a great many things which may be done with this foto electric cell and the editorial department of this publication would be very grateful to receive any comments on this article or any uses the professional set builder may have for the foto electric cell. The Raytheon Mfg. Co., Cambridge, Mass., who manufactures these foto electric cells, makes two models in four different types. One model is approximately a 60 watt electric lamp globe size, having for a base a standard UX socket. Fig. 5 illustrates this type of foto electric cell. The other type is of the tubular type, about 14 inches in length and approximately 2 inches in diameter. This has much more active service than the smaller tube, but otherwise the characteristics are practically the same. The two types of tubes may be obtained either in a gas filled or hard vacuum type, depending to what use they will be put.

Official Parts List

Parts used in the construction of the device described in this article are shown below:

Tell 'Em You Saw It in the Citizens Radio Call Book Magazine and Scientific Digest

- 1 2445 Thordarson transformer
- 1 R-196 Thordarson choke, 30 henry
- 1 10800-C Yaxley relay
- 2 Parvot 4 mfd 400 volt condensers
- 1 Frost 10 ohm center tapped resistance
- 1 Frost 1896 2000 ohm variable resistance
- 6 Eby binding posts
- 3 9040 Benjamin sockets
- 1 Amso grid leak mounting
- 1 Durham 2 megohm leak
- 1 11½x8x⅝ inch baseboard
- 1 8x4x3/16 inch bakelite panel
- 1 Raytheon 3GL foto cell
- 1 CX-374 regulator
- 1 Ray-X 226
- 1 Ray-X 280
- 1 301 Weston 0-10 MA milliammeter

ABC of Radio Section

(Continued from page 91)

signal strength will go down to the noise level. If such amplification is achieved by the tuned radio frequency, then there would be no necessity for supers. On the other hand, the advocates of the super assert that for the man who is anxious to secure distant reception and who wishes to have extreme selectivity, possibly at the sacrifice of some side bands, that the superheterodyne still the peer of all receivers.

Which one of these two camps will be victorious in its contention is hard to estimate, but at least it must be said that so far the majority of receivers are tuned radio frequency.

Multum in Parvo

THE Magnaformer AC-29, described in our January number, has a base of only 11½x24 inches. But it contains the ten tubes of the receiver, the humless A, B and C power supply with voltage regulator, the 12 mfd filter condenser and the 100 per cent shielding panels. There is nothing outside of the set but the speaker and the cord that connects the set to the electric light socket.

Single Dial Control

This "Superhet" has but one dial. But it has an equalizing arrangement, controlled by a knob on the front panel that permits of separate variation of the loop condenser, thereby making absolute resonance possible exactly as efficiently as though the two condensers were entirely separate, each having its own dial.

The volume controls are different from usual, permitting perfect control, even on the very strongest signals from super-powerful locals, from the faintest whisper to tremendous volume, as desired. One of the controls is quite distinctive, as it is used only on signals from distant stations, controlling the input impedance of the two a. c. shield grid tubes and one of the intermediate 227s. The other volume control governs the input to the second detector. This perfect volume control is secured without detuning the set in the slightest degree.

This receiver tunes sharply without cutting sidebands even with two shield grid tubes. This is partially accomplished by having the first detector a 227. The balance of the sharpness is accounted for in the modern engineering design of the circuit.

An outstanding advantage of the AC-29 is its long and short wave plug-in oscillator coils and antenna couplers for use with straight wire, outside or inside aerial. Listening to short wave broadcasting is becoming more and more interesting, as more and more stations are broadcasting on short waves as well as long ones. When the reception of long waves only is desired, the loop antenna is perhaps preferable on account of its directional qualities.

Phono-Radio Combination

This job is also equipped with a tip-jack panel for connecting to any phonograph with a phonograph pick-up, thereby affording

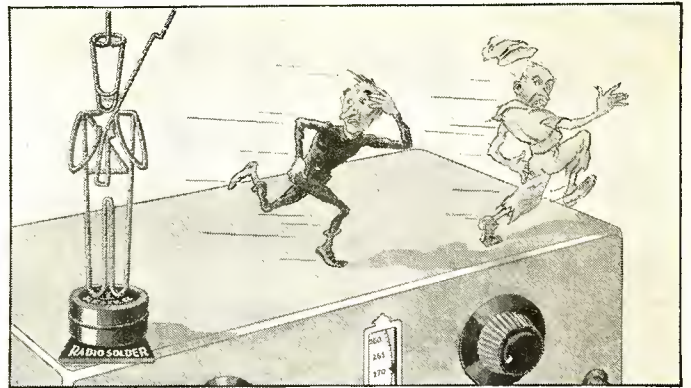

KESTER RADIO SOLDER routs the enemy—CORROSION and LEAKAGE

ENEMIES of the set builder—corrosion and leakage don't have a chance when KESTER Radio Solder is on the job.

With the best flux for radio—ROSIN—contained within the solder itself, you can do a real, professional job of soldering. "A touch of heat and it's done." Rosin flux is non-corrosive and non-conductive. It works in harmony with the insulations of the set.

KESTER Radio Solder (Rosin-core) is the quickest to use and safest for the radio.

Established 1899

CHICAGO SOLDER COMPANY
4226 Wrightwood Ave., Chicago

KESTER Radio SOLDER

Rosin-Core

Free We will gladly send you a generous free sample and directions for use. Write today!



Obtainable in the handy yellow tin package.

Remarkable!

In dignified beauty within and without—in luxurious comfort—THE DRAKE rightfully takes its place among the great hotels. In location it surpasses them all. Here the sun-swept waves of blue Lake Michigan invite your gaze; yet a few minutes' exhilarating walk and you are in the midst of the sights and sounds and surging movement of Chicago's world-famous Loop. Rates as low as \$5.00 a day single room with bath; \$6.00 double. The ideal year 'round home—special discounts for extended stays. Write for Illustrated Booklet, Edition 23.

Under the Blackstone management
the world's standard in hotel service



Lake Shore
Drive and
Michigan Avenue

HOTEL
CHICAGO

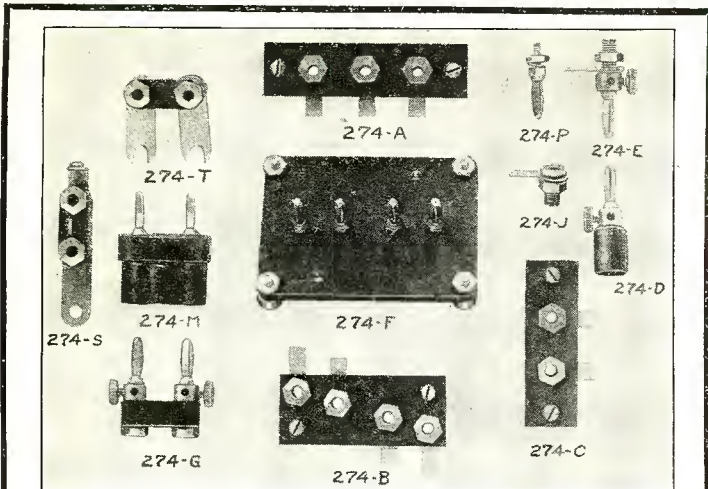

PLUGS AND JACKS

Twisted "haywire" connections are an inseparable part of the set which is never quite finished. Yet a fair trial of the circuit demands secure connections.

The General Radio plugs and jacks are ideal for the confirmed experimenter. They offer a means of construction which provides as good a contact as soldered joints, yet which may be altered instantly. Once a standard amplifier circuit is set up, coupling units mounted on plug plates are instantly interchangeable. Radio frequency coils, plug mounted, permit change of frequency range.

The collection of plugs and jacks evolved as need arose in the course of experimental work includes double plugs for speaker connections (and quick comparisons), short-circuit jacks for meter protection, and many other convenient, time-saving combinations.

Bulletin 931 will be sent on request. The General Radio monthly "Experimenters" will be sent free of charge to interested experimenters.

GENERAL RADIO Co

30 State Street
Cambridge, Mass.

274 Brannan Street
San Francisco, Calif.

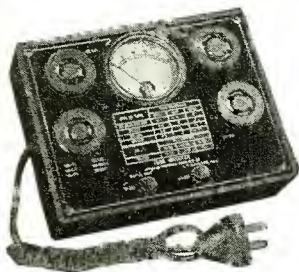

FLEWELLING Tube-Checker

Plugs in light socket.
Tests all tubes.
Equipped with Weston or Jewell meter.

List Price \$26.50

Write for attractive jobbers discount

THE RADIO PRODUCTS CO. DAYTON, OHIO

Manufacturers of the famous Flewelling Short Wave Adaptor
List Price \$22.50

Send for WESTERN RADIO'S Latest 1929 Catalog

THE New 1929 Catalog is crammed full of the FINEST, NEWEST, Nationally known A.C. sets, consoles, cabinets, dynamic speakers, kits, eliminators and accessories at Lowest Prices. Largest stock of radio parts. Prompt delivery. Write for our Free catalog.

WESTERN RADIO MFG. CO.
128 W. Lake St., Dept. CB-3, CHICAGO



"The Big Friendly Radio House"

the finest of orthophonic reproduction from old style phonographs. This is a feature that appeals to many.

By the addition of an output transformer the receiver can be operated with magnetic or cone speakers, which some prefer to the new dynamic speakers. Beautiful reproduction is secured on magnetic or cone speakers by reason of the volume and power from the 250 output tube. The volume and clarity are such that many distant stations are often mistaken for locals until the announcement.

The front panel is metal, is ready-drilled and very attractively decorated. The sub-panel is aluminum and is completely drilled, ready for assembly of parts. The set is compact and highly efficient and deserving of the phrase Multum in Parvo—meaning "Much in Little."

With the Accessory and Parts Manufacturers

(Continued from page 105)

hinges. Five 199 and one 120 tubes are employed. The set weighs slightly under 30 pounds, fully equipped with batteries and tubes. Where in the past the predominating factor in portable construction has been price, in the case of this receiver the Alvon Radio Laboratories have concentrated on quality.

Line of Condensers and Voltage Regulators Announced by Gerd

A NEW line of condensers is now being placed on the market by the Gerd Electric Co., Cambridge, Mass. The line will include bypass condensers, filter condensers, power condensers high voltage condensers and power blocks. In addition



This illustration shows one of the Standpeak 2 mfd condensers guaranteed for 600 volts d. c. continuous duty

to this, the Gerd organization is also marketing a transmitting condenser and an automatic a. c. voltage regulator.

An illustration accompanying this article shows one of the 2 mfd Standpeak condensers guaranteed for 600 volts d. c. continuous duty.

Tonal Quality of Radio Sets Affected by Impedance Differences

ONE of the essentials of good tonal quality, although universally recognized by radio manufacturers, is not always given proper consideration in the design and construction of receivers. This is the necessity of having the output impedance of the radio frequency stages match very closely the input impedance of the audio stages. Unbalanced impedances result in tube over-loading and other conditions detrimental to good clear radio reception. This is particularly true in sets employing dynamic speakers for the reason that the voice coil of the speaker is usually made up of a few turns of heavy copper wire having comparatively low impedance. Power tubes feeding directly into this coil should have their output impedance correspondingly low.

The use of the type 71 tube where 135 to 180 volts are available, or the use of the 250 tube, where high voltage (upwards of 450 volts) is available, gives much better reproduction of the low notes, and goes a long way toward eliminating tube overloading.

But the distortion due to tube overloading can be still further minimized, irrespective of what type power tube is used, by a small, inexpensive device called the Lynch Tubadapta, which reduces the impedance in the power stage by the simple expedient of connecting two power tubes in parallel. The result is the nearest approach to tone perfection that it is possible to secure.

Although ordinarily the use of two power tubes in parallel would involve troublesome, lengthy or expensive wiring changes in the receiver or power amplifier, the Lynch Tubadapta now makes it a simple operation requiring but a minute, and no knowledge of radio or electricity. A child can install it permanently in a receiver. Simply remove power tube from last audio socket, then place two power tubes (the old one and a new one of the same type) in the Lynch Tubadapta. Put Tubadapta, containing the two power tubes, in the audio socket of the receiver. It can only go in one way, just like a tube.

The current-capacity in the output of any receiver is now practically double.

Another advantage derived from the use of the Lynch Tubadapta is increased life of the power tubes because it goes a long way toward killing the evil effects of high voltage surges in the power lines. These surges have been creating havoc among the power tubes used in light socket receivers, particularly in suburban districts.

With due regard to space limitations and individual characteristics of different makes of receivers, the Tubadapta is made in several models and other models will be added as rapidly as possible, so it is important, at the present time, to mention the name of the set on which the Tubadapta is to be used in order to be certain that it will fit properly.

Service and Repair Notes

(Continued from page 96)

Volume unsatisfactory. If volume gradually decreases after the set is put into operation, run down batteries are indicated. Test A and B batteries. This symptom is characteristic of battery operated receivers only.

If volume is consistently unsatisfactory at all times, any possible cause of poor reception may be responsible. Trace the trouble as follows: Examine connections for wrong hook-up, loose or bad contacts, broken wires. Test batteries or eliminator, try standard tubes in place of tubes in set, examine aerial and ground systems, examine speaker, thoroughly test set in the shop and trace through the audio transformers, soldered connections and bypass condensers.

The set is not selective. The trouble here is too much pick-up or or amplification. Try a shorter aerial. If this does not help, thoroughly test set at shop especially the balancing.

Poor tone quality. Trouble in battery, tubes or grid leak is indicated. Test B and C batteries, or eliminator output B and C. Try standard tubes in places of those used in set. Try standard 2 megohm leak in place of the one used in set unless the set has a built-in leak, in which case examine the connections and replace the leak if you believe it to be defective. Check the speaker. Compare reception with that of standard set to make sure that distortion of the broadcasting station is not responsible for the difficulty.

Crackling Noises

Sharp crackling sounds interfere with reception. If the cracks are never followed by the set going dead, it is probably due to static or power line interference. It may be overcome to some extent by using a shorter aerial, an indoor aerial for instance, which merely reduces the pick-up, or by rearranging the aerial so it is nearly perpendicular as possible to interfering power line. If cracks are followed by set going dead temporarily, a loose connection or broken wire is indicated. Locate trouble as follows: By jarring set, jiggling lead wires, locate general neighborhood of trouble. Trace circuits on site of trouble for bad contact or broken wires. If trouble cannot be located, take it to the shop

HEAVY DUTY Rheostats and Potentiometers

by Carter



Diameter, overall: 2 3/8 inches
Depth, mounted: 1 inch
Price from \$1.75 to \$3.50

Elements wound on Asbestos covered Steel. One piece Cadmium plated frame. "Single hole mounting." Hot-tinned terminal lugs.

A sturdy line control for A.C. sets, "A" and "B" units, chargers, speed regulators for small motors, laboratory and experimental work, etc.

Stock units rated at one-half ohm to 25,000 ohms. Watts, 15 to 150.

Alert jobbers are finding a wide market for these Heavy Duty units.

Manufacturers' samples and quotations on request.

R. M. A.
Members

Carter Radio Company, Chicago
Carter Radio Co., Ltd., Toronto

Carter

THE NAME GUARANTEES
THE PRODUCT

For the New Tubes

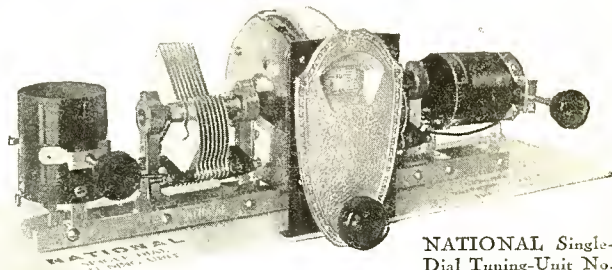

NATIONAL Single-Dial Tuning-Unit No. 222-A for A. C. Sets.

For the new R. C. A.—A. C. Shield-Grid Tube

This improved NATIONAL Tuning Unit embodies matched condensers for better single control, and coils designed for use with this wonderful new A. C. Tube.

For the new R. C. A. Power Tube

A special NATIONAL AB-Power No. 7180-A furnishes the 250 volts for plate and 50 volts bias—required for best operation of this latest power tube.

The NATIONAL A-100 Velvetone Audio-Transformer is designed to work into the same new tube.

Send for Bulletin 150, 150 CR.

**NATIONAL
RADIO PRODUCTS**

NATIONAL COMPANY INC., MALDEN, MASS.

In the Grand Central Section

HOTEL MONTCLAIR

Lexington Ave.
49th to 50th St.

New York's newest and finest Hotel
800 Rooms 800 Baths

Radio in Every Room

3 minutes' walk from Grand Central, Times Square, Fifth Avenue Shops and most important commercial centres, leading shops and theatres. 10 minutes to Penn. Station.

Grand Central Palace only 2 short blocks away

S. Gregory Taylor,
President

Oscar W. Richards
Manager

Room & Bath
Tub and Shower
\$3 to \$5
per day
For 2 Persons
\$4 to \$6
per day



Wholesale Prices

Tremendous stock and sales volume, with rapid turn-over to the thousands of radio dealers we serve enables us to make you worthwhile savings at lowest wholesale prices. Write for latest, new illustrated Catalog "C-3."

Allied Radio CORPORATION

711 W. LAKE STREET, CHICAGO

Ohmite

Vitreous Enameled Resistances

ALL SIZES—ALL TYPES

OHMITE MFG. CO., 634 N. Albany Ave., Chicago, Ill.
Pacific Coast Office: 905 Mission St., San Francisco, Calif.

SMALL AD-LOWEST PRICES

DEALERS! Our common sense merchandising and economical methods of selling enables us to quote lowest possible prices on nationally known **Radio Sets, Kits and Parts.** This small ad is an example of our economy. Instead of spending money extravagantly for large magazine space we save this expense and pass it along to you in the form of Lower Prices. **Send for our wholesale Radio Catalog.** Use your letterhead when requesting this book.

NEW ENGLAND MILLS COMPANY

853 WASHINGTON BOULEVARD

CHICAGO, ILLINOIS

and thoroughly test, especially audio transformers, connections and bypass condensers. Be sure first, however, that the bad condition is not in the battery, aerial or ground leads, or elsewhere outside of the set.

Set squeals and howls. Something may be causing the set to oscillate badly. Be sure, however, the squeals are not heterodyne beats due to interfering stations or the radiating sets in the neighborhood. Test as follows: Try standard tubes in place of the ones being used, check the ground system for poor connections or broken wires. In some of the older models, a longer aerial will help. Run-down B and C batteries or improper battery voltages may cause this trouble. Test set at shop for proper balancing, defective audio transformers, connections, etc.

Cause of Microphonism

Ringling sound shows up in speaker when set is operating. This trouble is known as microphonism, and is due to the speaker affecting the tubes, causing the elements to vibrate so that impulses are sent to the speaker, which make it vibrate still further and so on, the vibration building up by a kind of regenerative process. The remedy with table type sets is to remove the speaker as far as practical from the set. In the console models, other tubes should be tried, since some tubes are more rugged than others of the same type. Try weighting down the tubes.

Set hums. If it is an a. c. model, first try reversing the prongs of the end of the power cord in the socket to which they are connected. If the set has not external power unit, move power converter as far from set as possible. If it is a d. c. model, proceed as follows: Examine ground system, see that a. c. lead cord is as far from set as possible. If possible turn off a. c. current supply to these cords when operating set. Examine aerial to see if it is parallel to a. c. power line nearby. Trouble may be due to faulty power system in your vicinity.

Set works best on short waves or long waves. Some difference is natural because of the greater transmitting efficiency on short waves. If difference is extremely pronounced aerial and ground system resonating at wavelength range where reception is best, or improper balancing is indicated. Try different aerial and ground system, and test balancing.

Set receives best in one direction. Some directional properties are a natural result of location. If difficulty is pronounced it may probably be helped by changing direction of aerial or raising it above nearby objects which are shielding it.

Signal fades. If they fade only on certain stations, the trouble is probably due to uncontrollable atmospheric conditions between the set and the station, or to a radiating set in the neighborhood. If signals of all stations fade, test batteries or power supply unit. If a light socket set is being used, check the line voltage to see whether or not it remains constant. Check aerial and ground system for poor connections, swinging aerial, bad insulators, objects grounding aerial system. Check external and internal wire connections for corroded terminals or defective soldering.

Crosley Gembox Model 608

In Fig. 6 we are showing the schematic diagram of the Crosley Gembox, model 608, a. c.

This is a six tube, including rectifier, circuit with two neutrodyne radio frequency stages, regenerative detector and two transformer coupled audio frequency stages. The second radio frequency and detector stages are tuned, the first being untuned. Volume is controlled by a rheostat connecting across the primary of the antenna choke coil, and the ground lead taken from the rheostat slider.

Regeneration is secured by means of a small variable condenser connected from the detector plate to the plate of the second r. f. tube. The amount of regeneration may be controlled by adjusting this condenser.

A small adjustable aligning condenser shunted across the detector stage tuning condenser serves as a means of aligning the tuning condenser so that they track together properly.

The model 608 uses a UY 227 detector, UX 171-A output tube, and UX 226 tubes in all other stages. All of these tubes use a. c. for their filament supply.

The necessary filament current is obtained from three separate secondary windings on the power supply transformer. One of these delivers 1½ volts a. c. to the 226 type tubes, another furnishes 2½ volts a. c. for the heater of the 227 detector tube and the third supplies 5 volts a. c. to the filament of the 171 output tube. Filament current for the 280 rectifier tube is obtained through a fourth secondary with the middle tap, which supplies 5 volts a. c. A fifth secondary on the power transformer furnishes 220 volts a. c. for the B and C supply. Current from this secondary is rectified by the 280 tube. In a 60 cycle unit, one side of the secondary is connected to ground and the other side to the two plates of the rectifier tube. Thus, half wave rectification is obtained. In the 25 cycle unit, the transformer secondary is connected the same as in model 706, so as to obtain full wave rectification.

The high potential lead to the rectified B current is connected to the mid tap of the secondary, which supplies filament current to the 280 tube. From there it leads to a filter circuit consisting of a choke coil and Merphon condenser.

The plate circuit of the last tube is connected directly to the high line. The grid circuit is connected to ground. A potentiometer consisting of two 25 ohm resistance units in series is connected across the filament supply. The center tap of this potentiometer is grounded to a 1650 ohm resistor. The drop through this resistance furnishes the grid bias voltage of about 25 to 40 volts negative. The plate voltage is from 135 to 150.

The plate circuits for the radio frequency and first audio frequency stages are connected to a 3250 ohm resistance to the high line. This resistance serves to reduce the B voltage to the proper value for operating these tubes. The grid circuit of these tubes are connected to ground, and the ground low line is connected to the filament through a 460 ohm resistance unit, one end of which is grounded and the other end joined to the mid tap of a 50 ohm potentiometer shunted across the filament leads. The voltage drop in this resistance is such as to put about 8 volts negative on the grids and 115 volts positive on the plate.

In order further to reduce the B voltage for the detector tube, its plate circuit leads through both a 60,000 ohm resistance unit and the previously mentioned 3250 ohm unit to the high line. The grid and emitter are both connected to ground. They are consequently at the same potentials, that is, there is no C bias on the detector grid. The drop in the plate resistance is such that the plate is kept at about 30 volts plus with respect to the emitter.

Crosley D. C. Showbox, Model 705

Another interesting model made by Crosley is known as the d. c. Showbox, model 705, which is designed to operate from 110-120 volt direct current lighting systems.

An eight tube circuit is used consisting of three stages of neutrodyne radio frequency amplification, the second and third being tuned, a tuned non-regenerative detector, and three stages of transformer coupled audio frequency amplification, the output stage being of the push-pull type. This is illustrated in the circuit diagram shown in Fig. 7.

Volume is controlled by a rheostat connecting from antenna to ground. Filaments of all tubes are wired in series, the negative line lead connecting the output tube bias resistance and the circuit going from there to the output tubes; second audio, first audio, third radio, second radio, first radio and detector tubes. A 200 ohm resistance is placed across the filament of the last tube to obtain direct voltage.

The necessary grid bias is obtained by means of a resistance and filament voltage drop. The output tubes are biased by the drop in a series resistance of 11 and 21 ohms.

The voltage drop in the positive line leads through the filament choke and the 95 and 45 ohm resistances to filament terminals of the various tubes supplies the necessary B voltage. The plates of all tubes are connected to the high line.

Immediate Deliveries ALL Parts for NEW Magnaformer AC-29

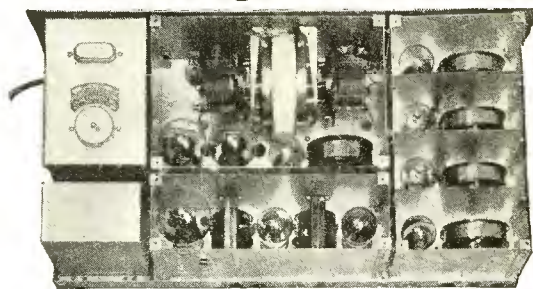

Top and Rear View of the New Super-Powerful All-Electric AC Shield Grid Magnaformer AC-29

For a whole of a thrill and the greatest satisfaction you have ever had from any radio receiver, build this Super-Powerful, Super-Sensitive, Super-Distance-Getting, Super-Selective and Super-Tuned 10 Tube. It brings in DX with a tone and a wallop that surprises everybody. 2000 miles is local. All Electric. Complete. Nothing outside but light socket connecting wire. Latest AC Shield Grid Tubes. Humless AB&C Power Supply with voltage regulator. 100% Shielded. Single Dial. No Harmonic Repeats. Loop or Straight Wire Aerial. Inside or Outside Antenna. Long and Short Waves. Plug-in Oscillators and Antenna Couplers. Phonograph Connections. Dynamic or Magnetic Speaker. Compact, only 11 1/2" x 24". Panel-ready-drilled. Easy to Wire. A Wonder Set. This NEW job possesses every advantage known to Modern Radio Engineering. Not only up to date, but far ahead of the field. It is just the job to build for particular customers who want only the very best. You can get more money for this job and there is no after-service. Every customer is a constant and enthusiastic advertisement for you. Send today for X-Ray Wiring Diagrams and complete information about this NEW All-Electric Shield Grid Magnaformer and our latest catalogue and Radio-trician's Special Discounts.

We Are Wholesale Distributors of All High Grade Radio Apparatus

We Specialize on Parts for

- New Magnaformer AC-29
- Magnaformer 9-8
- Victoreen DC and AC
- Tyrman 80, 60 and 72
- Scott Screen Grid Nine
- Remler No. 29—115 K.C.
- National Browning-Drake Units
- Silver-Marshall Apparatus
- Kuprox Apparatus

Hammarlund and Aero Short Wave Kits

NELSON ELECTRIC COMPANY

508 SOUTH DEARBORN ST. CHICAGO, ILLINOIS

NEWAY LACQUER SPRAY ELECTRIC PORTABLE

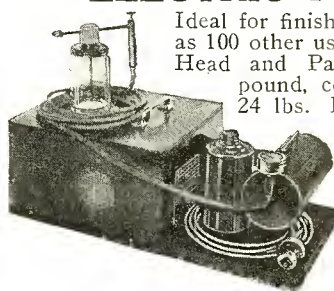

Ideal for finishing radio cabinets, as well as 100 other uses. Light in weight, Spray Head and Paint Container weigh one pound, compressor unit and motor 24 lbs. Easily portable — powerful air cooled motor for 110 Volt A.C. or D.C. current. Plugs into any light socket. Complete with 15 ft. hose, 8 ft. extension cord, ready for use, \$37.50 prepaid. Descriptive matter on request.

Also Hand Spraying Devices, \$1.65 to \$9.45
New Way Spray Gun Co., 5711 Euclid Ave. Cleveland, O.

Lowest Wholesale Prices!

Set Builders and Dealers!

Let the largest Radio Mail Order House in the East serve you!
You'll get better service and better merchandise at the lowest wholesale prices obtainable anywhere.

NEW 1929 BUYING GUIDE

Your copy is ready for you. It lists all the latest Radio Parts, Accessories, Sets and Kits. Catalog K also lists Electrical Supplies, Household Appliances, Golf and Tennis Equipment, Cameras, Traveling Bags, etc. Send for your copy now. It's free.

Allen-Rogers-Madison

35 WEST 31ST ST. NEW YORK, N.Y.



**Without A Doubt
The Most Complete Line of
Condensers & Resistors**

Filter Blocks
Buffer Blocks
Socket Power
High Voltage
Transmitting
Bypass
"A" Power
Bakelite Moulded Mica
Condensers
Interference Filters

Pyrohm Heavy Duty
Edison Base Pyrohms
Tapped Pyrohms
Wire Wound Units
Grid Suppressors
Center-Tapped Units
Non-Inductive Lavites
Grid Leaks
Resistorformer Kits
Resistor Mountings

A COMPLETE CATALOG with illustrations and detailed descriptions may be obtained free of charge on request.

with illustrations and detailed descriptions may be obtained free of charge on request.



The Aerovox Research Worker is a free monthly publication that will keep you abreast of the latest developments in radio. Your name will be put on the mailing list free of charge on request.



**HOTEL
FORT SHELBY**
Lafayette and First, Detroit

**New
22-Story
Addition**

equipped with every advanced feature of accommodation including **SERVIDORS**

WHETHER your choice be one of the very comfortable rooms at \$3, \$4 or \$5, or one of the especially large rooms or suites in the new addition, with an entrancing view of city, river and Canadian shore, you will enjoy a special sense of value in Hotel Fort Shelby.

Convenient to all downtown and to all transportation. Shopping, theatrical, financial and wholesale districts within five minutes' walk. Garage in connection. Cars delivered without service charge. *Brochure on request*

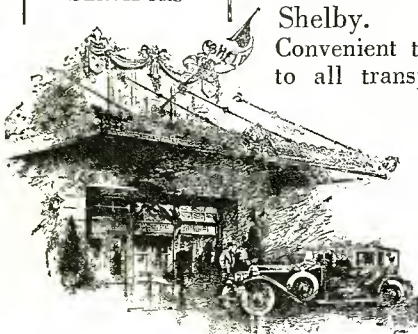

Look for Large Green Sign on Roof

Because of the voltage drop in the filaments themselves, the B voltage is different on the different tubes. The highest voltage is applied to the output tubes and then decreasing voltages to the second audio, first audio, third radio, second radio, first radio and detector tube.

An elaborate filter system is used to keep out line interference and hash. The radio frequency chokes and the fixed condenser shunted across the line serve to cut down high frequency interference. The audio frequency chokes and the Mershon condenser further help to eliminate line noises.

In later issues of this magazine we will give from time to time the circuit diagrams and interesting service notes covering many of the other manufactured receivers now available on the American market. We would be glad to hear from our readers as to which particular receiver they are especially interested in and, if possible, we will arrange to cover those particular models fully.

In order to facilitate learning the opinion of our readers on the Service and Repair Department material we suggest they read carefully the questionnaire on page 117 and then give us the benefit of their wishes with respect to the material included in this department.

The Editor.

Profitable Summer Line

FOR some time past, radio set dealers and even custom builders have been considering the possibility of taking on some line during the summer months, which might take care of their overhead and enable them to continue operation as actively during the summer months as during the colder weather.

Our technical department is now going into the subject of electric refrigeration as a means of sales possibilities for dealers and builders during the summer. In our forthcoming issue, we expect to have some material worked up on this subject for presentation to our readers.

In the meantime, we would like to know the extent of interest in this particular subject, especially as to whether the dealers believe that in taking on a line of electric refrigerators they would be able to keep their organizations going as a steady pace through the warm months of the year.

It is also possible that in addition to electric refrigerators, there may be some other lines which is might be profitable for dealers and builders to carry. Due research will be made by our technical department and its findings published in a forthcoming issue.

They Believe in Signs Out There



Automobile Club of Southern California has begun the replacements of 200,000 road signs with new ones conforming to the standards of the uniform system of road marking adopted by the American Association of State Highway Officials and Bureau of Public Roads of the Federal Government. Marking of public highways with adequate signs had its origin in Southern California and for 25 years the auto club has been placing and keeping these markers, both on broad thoroughfares and desert trails

2LO Rebroadcast Over Chain



Photo Wide World

Dr. Alfred N. Goldsmith, vice president of the Radio Corporation of America and consulting engineer of the plant operations and engineering, throwing the switch which made available to radio listeners throughout the United States a radio program of music being presented in the studios of the British Broadcasting Co. in London, England. The program traveled 3300 miles before reaching the United States and then it was transmitted over stations from coast to coast here through the NBC system, from 4:45 to 5:10 p. m., eastern standard time

New Paoma Dam Completed

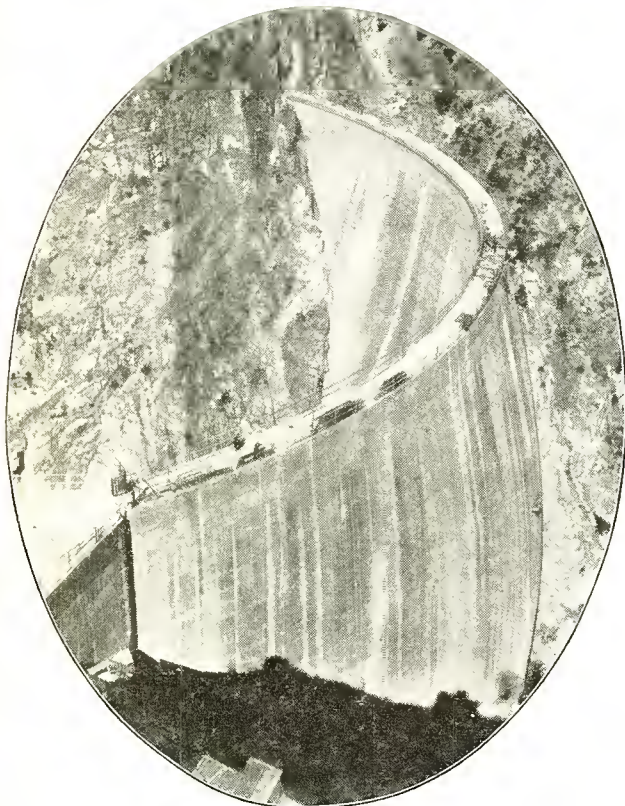

After four years of work, the Paoma Dam, a part of the flood control of Los Angeles County for the San Fernando Valley, has been completed. The dam cost \$2,500,000 to build; stands 365 feet high; drains 25 square miles in the Sierra Madre Mountains; is of constant angle arch construction, 100 feet thick at the base and 660 feet wide at its crest and has a maximum stress of 600 pounds to the square inch

Used Radio Bargains!

Guaranteed perfect working order. BLUE RIBBON 5 tube, 2 dial. Console \$19.95. FRESHMAN \$14.95. ATWATER KENT \$19.50. Many famous makes. Send money order with order. Bargain List on Request

SURPLUS RADIO CO., Dept. 30-G, 549 S. Wells, Chicago

The Braxton-King Shield Grid Eight

Tunable Intermediate Units
One Spot Reception
No Oscillation

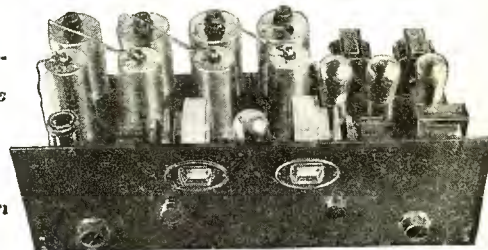

NOTE: We are prepared to convert your present super into a Braxton-King Shield Grid Eight, utilizing all of your present parts with exception of the I. F. transformers and oscillator coil. Write for prices on this special work. Set of four Transformers \$25.00.

MISSISSIPPI VALLEY RADIO COMPANY
914 Pine Street, St. Louis, Mo.

The New KARAS AUDIO TRANSFORMER

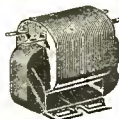

The Karas Universal Unshielded Audio Transformer fills the need of radio set manufacturers, set builders and service men for a small, compact, modern audio transformer at a most reasonable price. It can be used to replace and modernize 98% of audios now in use in radio sets. Its great utility and universal application have given it great popularity. It will solve the radio man's perplexing problem of always having on hand the proper audio for the job in hand. List price, only \$2.25.

KARAS ELECTRIC COMPANY 4026-C N. Rockwell St., Chicago, Ill.

NEW YORK'S NEWEST HOTEL
THE PICCADILLY
227 West 45th Street
at Broadway
NEW YORK
ADJACENT TO EVERY ACTIVITY
600 BRIGHT SUNLIT ROOMS,
EACH WITH BATH, ELECTRIC
FAN, ICE WATER
SINGLE ROOM ^{with} BATH \$3⁰⁰
DOUBLE ROOM ^{with} BATH \$4⁰⁰
EXCEPTIONAL RESTAURANT ^{with} LUNCHEONETTE
WIRE AT OUR EXPENSE FOR RESERVATIONS
F. D. SOFIELD - Managing Director

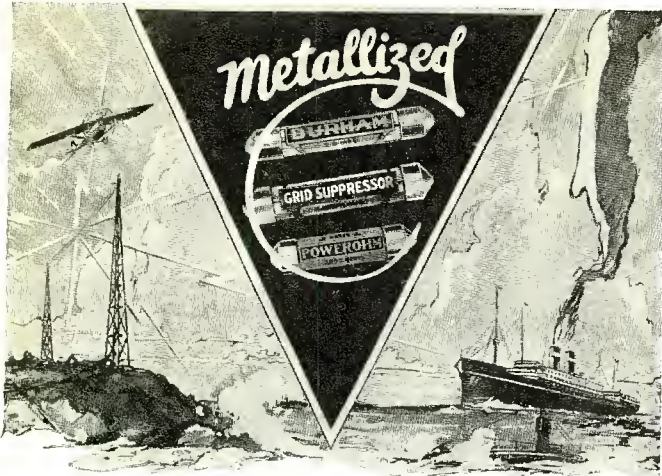

**On Land, Sea, or in the Air,
DURHAMS are Supreme!**

—wherever the perfect operation of radio apparatus is of paramount commercial and governmental importance—in radio transmitting or receiving apparatus—in power amplification units—in the sensitive resistance-coupled amplifiers of the photo-electric cell circuit in Television apparatus.

Years of experiment have proved the indisputable value of the DURHAM Metallized principle, calibrated accurately according to their stated ratings. We will be glad to send you descriptive literature explaining the entire Durham line. International Resistance Co., 2006 Chestnut St., Philadelphia.

DURHAM
METALLIZED
RESISTORS and POWEROHMS

WRITE TODAY

Send for large, new, illustrated Catalog "C-3," showing the latest of everything in radio at wholesale prices.

Allied Radio CORPORATION
 711 W. LAKE STREET, CHICAGO

WE specialize in constructing and repairing all types of A and B power units.

RADIO SERVICE LAB'S 440 S. Dearborn St. CHICAGO, ILL.

TOBACCO HABIT BANISHED

Quick Sure Lasting Results

Tobacco Redeemer banishes the habit completely, almost before you know it. Absolutely scientific, thoroughly reliable treatment. No matter how long or in what form used, you will have no craving for tobacco after you take this pleasant, inexpensive treatment. This we positively guarantee. Money returned without question if not satisfied. Write for free booklet and proof of what Tobacco Redeemer has done for men addicted to tobacco habit. Send postcard or letter today.

NEWELL PHARMACAL COMPANY
 Dept. 864 Clayton Station St. Louis, Mo.

May Scrap Plane Carriers

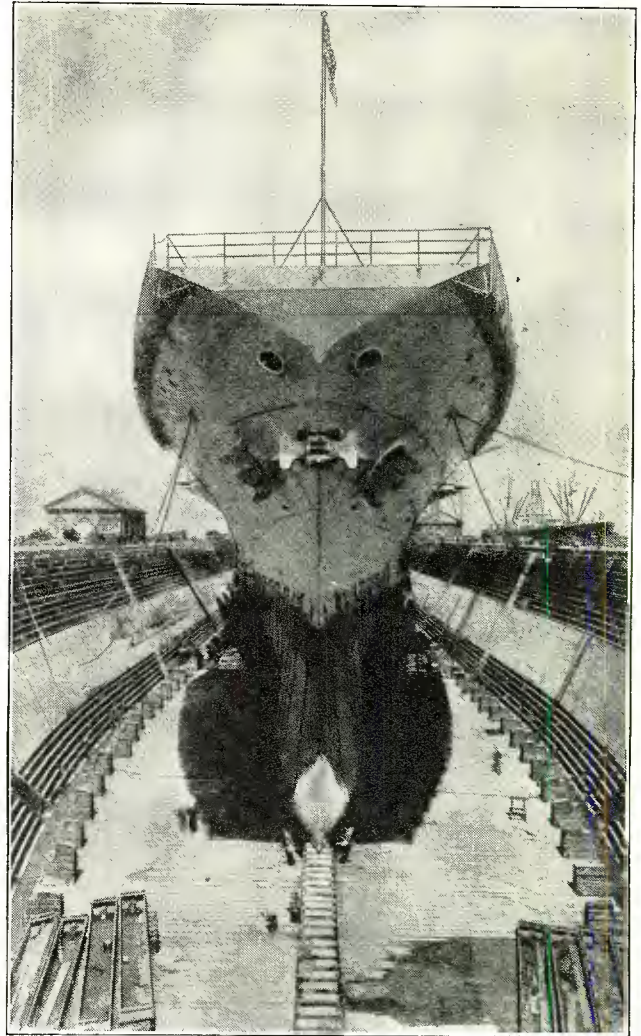

A view of the giant airplane carrier, U. S. S. Saratoga, in drydock at Balboa, Panama Canal Zone, before the recent war games off the canal. Naval officers have declared that the Saratoga and her sister ship Lexington are obsolete and should be scrapped

Markers to Guide Flyers

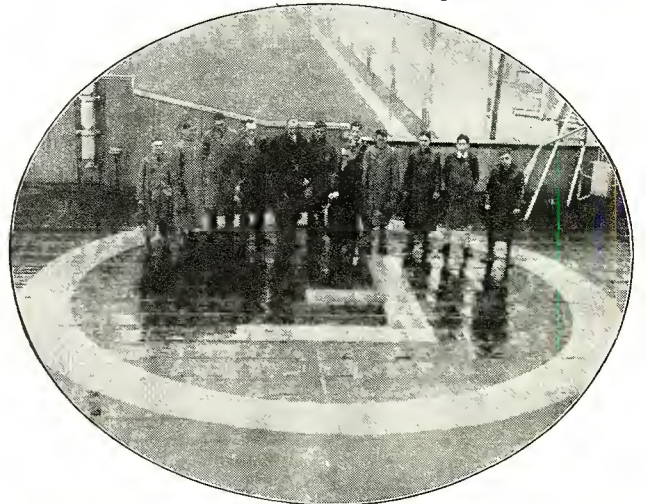

Assistant Secretary of Commerce William P. McCracken, Jr., accompanied by Harry H. Blee and John Groves of the Aeronautics branch of the Department of Commerce, are here shown inspecting the first airport marker to be erected in accordance with a standard system of air marking recommended by the National Airway Marking Committee for general use throughout the U. S. This marking is located on the roof of the Tacoma Park Theatre in Washington and was erected by Tacoma Park Troop No. 36, Boy Scouts of America. This marking consists of a 24 ft. circle, the standard symbol for an airport, and the letter "F" within, indicating the field is a federal airport

Planes Use New Aerial System



A new type of aerial has been devised for the Imperial Airway machines, which overcomes the necessity of winding in the aerial when near the ground. Photo shows operators receiving messages from planes at the Croyden control tower

Canned Broadcasts for Stations

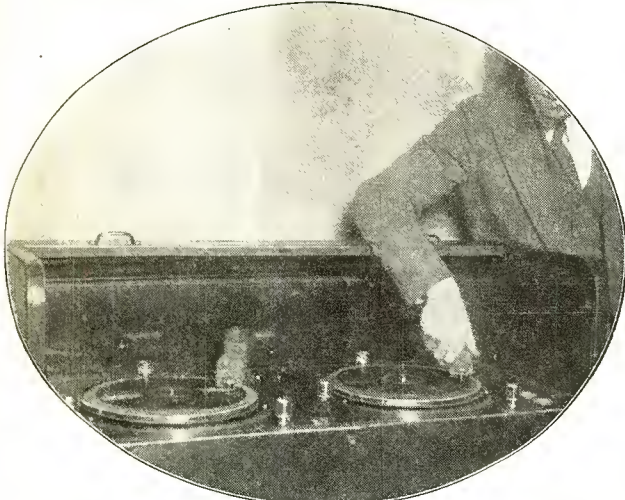

A system whereby radio broadcasts are transcribed on vulcanite or wax discs for simultaneous use by broadcasting stations is the accomplishment of John R. Kiel, 25 year old radio mechanic, who has perfected a machine which will make possible radio programs of a higher type, without the necessity of transmission by wire

Now It's the Aerial Ambulance!

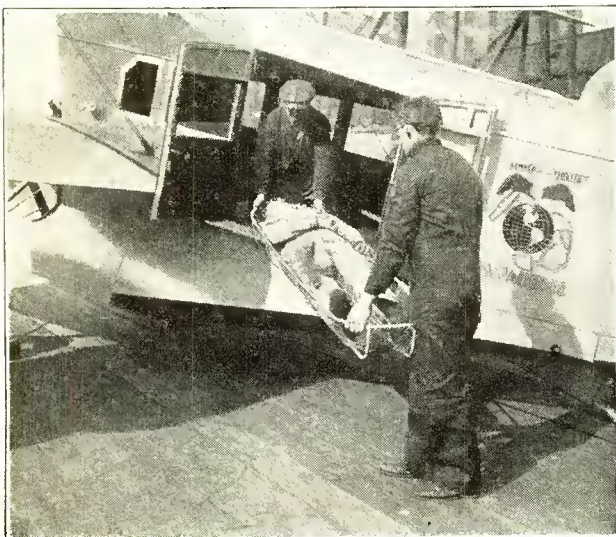

An amphibian plane which can be converted as a carrier for two stretchers, and can be used in transporting wounded men quickly from land or water

FREE!

All owners of electric radio sets should have one of these A.C. LINE VOLTMETERS. Tells at a glance the exact voltage of your house line, also serves to warn you of a high voltage which might cause damage. Ideal for the Service Man's Kit.

This high grade Tester, furnished with plug-in cord, finished in Dark Green Cracked Enamel, will be sent absolutely FREE with one (3) Year Subscription to the CITIZENS RADIO CALL BOOK MAGAZINE. Yearly subscription \$1.75 per year.



Mail this coupon today!

Citizens Radio Call Book Magazine,
508 S. Dearborn St., Chicago, Ill.

Here is my \$5.25 (Foreign \$6.00) for which send me YANKEE LINE A. C. VOLTMETER FREE and enter my subscription to the Citizens Radio Call Book Magazine for three (3) years, starting with the

January March September November Issue

Name

Address

City State

Send for WESTERN RADIO'S
Latest 1929 Catalog

FREE
ACWESTRAD
7-TUBE
\$34.95
WESTERN
RADIO

THE New 1929 Catalog is crammed full of the FINEST, NEWEST, Nationally known A.C. sets, consoles, cabinets, dynamic speakers, kits, eliminators and accessories at Lowest Prices. Largest stock of radio parts. Prompt delivery on New AERO A.C. Converter. Write for our Free Catalog.

WESTERN RADIO MFG. CO.
128 W. Lake St., Dept. CB-3, CHICAGO

"The Big Friendly Radio House"

Spring and Summer in LOS ANGELES

EVERY DAY A RIOT OF SUNSHINE
NO RAIN—NO WIND

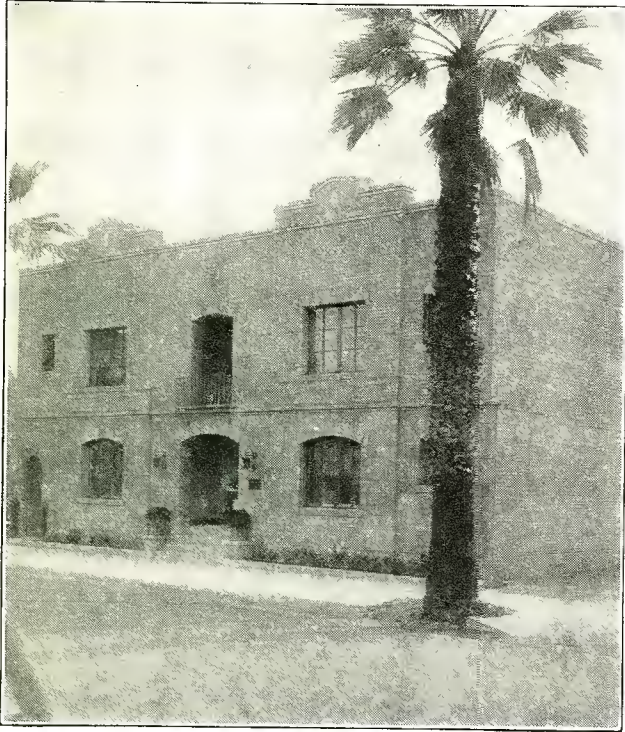

Write EL CORTEZ APARTMENTS

For Reservations

~
CLOSE TO EVERYTHING
516 West 31st St., at Figueroa

~
New Strictly Modern Housekeeping
Apartments — With Hotel Service

Two Rooms and Bath with Complete Hotel
Service \$25 Weekly—\$100 Monthly—
Also Single

~
[TELEPHONES]
Humboldt 7107-8023 []

Instrument Measures Paint Color

Hit and miss methods of mixing paints will soon be replaced by mathematical methods when the results of an investigation into the strength of pigments used in making tints completed by the U. S. Bureau of Standards are put into practical use.

The Bureau has measured with the spectrophotometer the color value of 104 different mixtures of pigments combined with a standard color.

The investigation has disclosed the exact strength and amount of a pigment that should be mixed with a standard color to bring a given result. The investigation is hoped to result in a numerical color value being given to each pigment instead of the mixture depending on more or less uncertain methods of comparing shades.

Portable X-Ray Machine

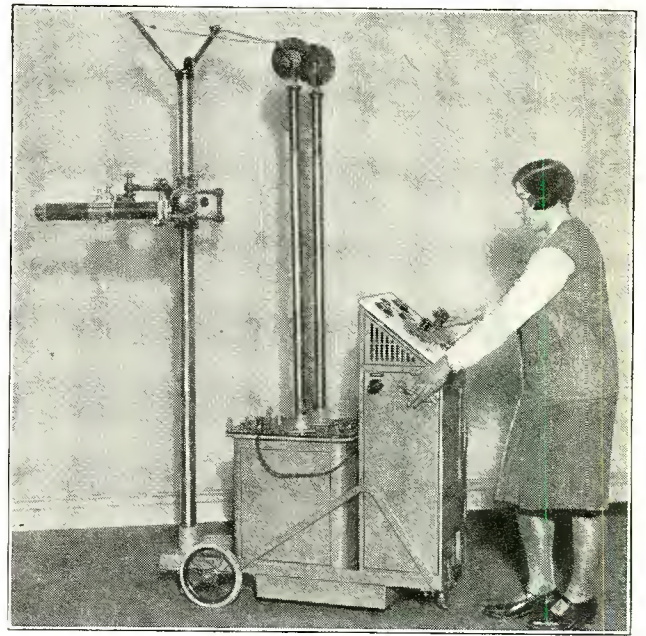

Photo Wide World

The exhibition of X-ray apparatus held by the British Institute of Radiology opened at the Central Hall, Westminster, recently. Photo shows an X-ray set for pushing around the hospital wards, etc., thus allowing the apparatus to be brought to the patient, instead of vice versa.

Hollow Propeller Blades Used On Navy Airplanes

Hollow bladed propellers made of a special steel may soon drive navy airplanes through the air. Air screws of the new construction and design are now being tested.

The Navy Department recently let a contract for six experimental propeller blades of an entirely new construction. The new propeller is of hollow chrome vanadium steel and is said to be the first one of hollow construction to stand the great strains imposed by a high speed airplane. Efforts to develop such a blade have been made for the last ten years but they all met with failure because no satisfactory method of welding the two sides of the propeller together could be found. By using a new process of electric welding, the new propeller was fabricated so as to be as strong as those of aluminum alloy and other materials now in general use by the Navy.

The greatest advantage of the new propeller is that it can be produced at two-thirds of the cost of present equipment. Preliminary tests with twice the normal load, recently completed on the first of the propellers, indicate that the new blade will meet all requirements and the Navy plans to advertise for bids for a large number of the hollow propellers within a few months.

Cathode Rays Trace Lamp Flicker

How a beam of cathode rays, tracing a luminous green line on a screen, can be used to study the flickering of electric lamps, was described recently at the meeting of the National Academy of Sciences by Prof. Frederick Bedell of Cornell University.

An electric incandescent lamp, lighted by alternating current, used in most cities, is constantly flickering. With 60 cycle current, commonly used, the lamp reaches its maximum candle-power a hundred and twenty times a second.

"The flicker is often of sufficient magnitude to be obvious to the casual observer," said Prof. Bedell. "A quick turn of the eye makes one conscious of it. Even when not obvious, the flicker is not infrequently a source of unconscious annoyance."

Previous methods of measuring this flicker have been indirect, and required many hours to determine the changes during a single alternation of the current. Now, with the use of the cathode ray oscilloscope, as the instrument is called, the light from the lamp being tested shines on a photoelectric cell. The cell gives a slight current, varying with the light. This is amplified, and it controls the path of the narrow pencil of cathode rays in the oscilloscope. As the rays strike a screen, it shines with a greenish light, and this light forms a curve that tells the exact variation of the brightness of the lamp. This curve can then either be traced or photographed.

Let Us Build Your New Magnaformer AC-29 or Supply You With the Parts

PERFECT. Wired-to-order. Laboratory model duplicates as samples and demonstrators for professional set builders and for service stations and dealers and the man who just wants one for his own use. We can give you anything you want in quick order; parts, wired chassis only or in attractive table or console cabinet; for loop or aerial operation; also separate or built-in Dynamic Speakers that do not hum; also Phonograph Pick-up connection; also Tubes. We supply everything promptly. Our wired jobs are beauties—done by experts.

The Magnaformer AC-29, described in Spring number of Citizens Call Book, is the most powerful set in the world, and it drags in far greater distance than any other receiver. We HAVE PROVED these facts. It also possesses astonishing tone quality on distant signals. For tone quality on locals it has no equal in any factory built set or any other custom built set. We specialize in building Magnaformers having built hundreds of them during the past three years. Our customers have the best there is in radio. Tell us what you want and we will serve you quickly.

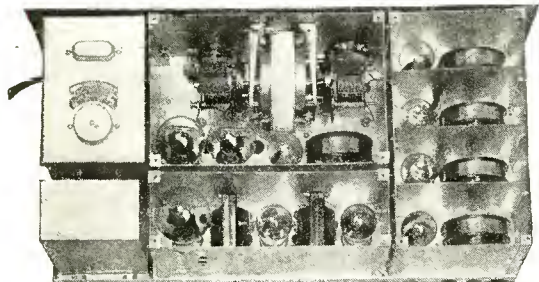

View of Compact, 100% Shielded Laboratory Model Magnaformer AC-29 with tops of shields removed showing location of parts, tubes, humless and noiseless A B & C Power Supply and Filter Condenser. All of our Wired-to-order Jobs are EXACT duplicates of this Laboratory Model.

Send today for our attractive prices on parts, wiring, cabinets and speakers

RADIO SERVICE & SUPPLY CO.
12700 Superior Avenue Cleveland, Ohio

BEAUTIFUL WALNUT CABINETS

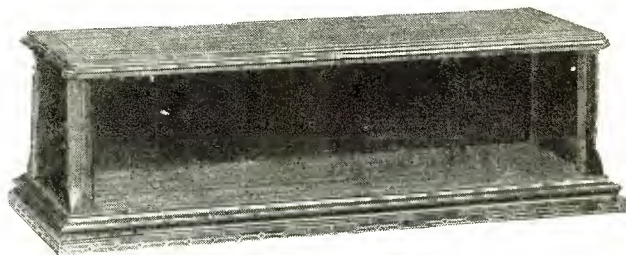

At Unheard Of Prices

1,000 MATCHED BURLED WALNUT CABINETS, Austrian Inlay on top, front and sides. All Walnut construction throughout, beautiful finish inside, nickel plated piano hinge. Size over all, 34 inches long, 12¼ inches wide, 11 inches high. Inside measurements 30 inches long, 9¾ inches wide, 7½ inches high.

Suitable for Supers or any high class job. This cabinet would cost over \$20.00 each, in 5,000 lots to duplicate. Will sell entire lot or quantities of twelve (12) or more at wholesale prices.

(SINGLE CABINET)
\$1000

**PROFESSIONAL SET CONSTRUCTORS
AND MANUFACTURERS**

Will find WHOLESALE PRICE on entire lot or parts of lot very attractive.

**RADIO SERVICE
LABORATORIES, INC.**

440 South Dearborn Street
Chicago, Ill.

NEW MARCH 1929 ISSUE ON SALE NOW!

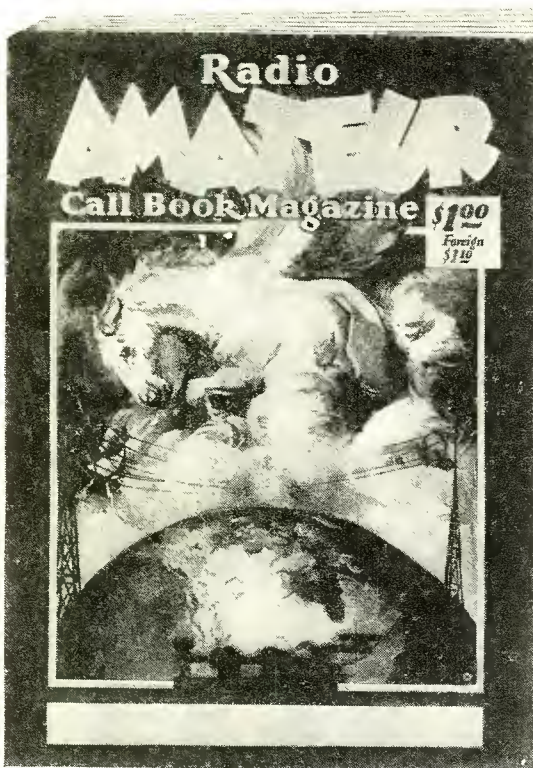

WE are pleased to announce the appearance of our first 1929 number, with the following new features:

NEW PREFIXES now in use by amateurs in all parts of the world. You need this issue to identify stations heard, as the old Intermediate system has been replaced by the new Prefixes, such as D, OA, X, ZS, etc. We have the most complete list published.

WHO'S WHO ON SHORT WAVES

A brand new section, giving frequency, call, and location of commercials, shortwave fones, television stations, etc., to be heard between 3,000 and 30,000 Kilocycles. Amateur bands are shown in heavier type, so that you can quickly find stations heard above and below the various bands.

Lists published elsewhere are no longer reliable, due to many changes in call letters and shifting of commercial frequencies. This is THE LIST you have been waiting for, giving hundreds of stations heard nightly all over the world.

NEW AMATEUR CALLS

have been assigned in many countries. Due to the adoption of the new Prefixes, many lists of amateur calls have been changed completely. Radio AMATEUR Call Book for March, 1929, is the ONLY publication giving latest correct information on these calls. The issue also includes hundreds of U. S. and Canadian amateur calls just recently assigned. The U. S. 6th and 9th Districts especially, have issued many new amateur station licenses.

We were sold out early on the December, 1928, issue, so use the coupon and get your big MARCH number NOW.

Radio AMATEUR Call Book, Inc.
508 S. Dearborn St., Chicago, Ill.

Here's my \$3.25 (Outside U. S. and Canada \$3.50) for the MARCH June, September and December numbers. Single Copies \$1.00 (Foreign \$1.10).

Name Call
Street
City State

Government Test Chamber Imitates High Altitudes

The United States Bureau of Standards will possess the only aviation motor testing chamber in the world capable of reproducing in the laboratory flying conditions seven miles in the air upon completion of the Bureau's present equipment now under way.

The improved chamber can be so regulated as to produce any desired conditions of temperature, density, air pressure and

New Thrill from Motor Ski

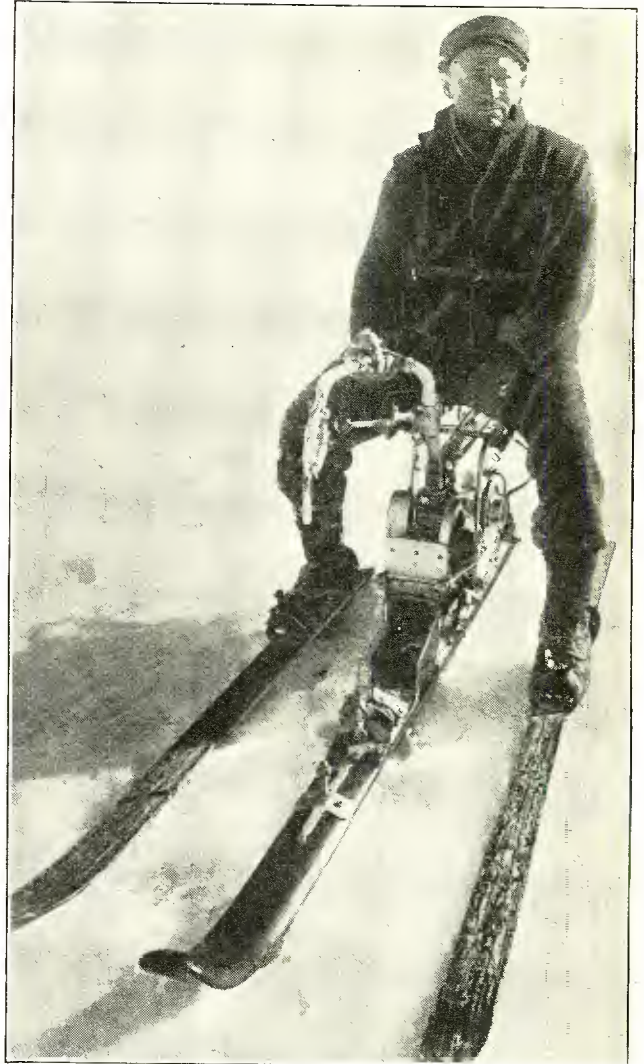

Photo Wide World

A new thrill is provided for visitors to St. Moritz in the motor ski, a device by which lovers of the great out-of-doors may make their way across the snow fields without effort and at a goodly rate of speed

other vital factors affecting motor performance at any altitude at which planes can fly.

This chamber is used in conjunction with other laboratory equipment to aid manufacturers to perfect aviation motors. Under the air commerce regulations of the Department of Commerce all motors of a new type must receive the approval of Bureau of Standards engineers before being placed on sale. These motors are each given a 50 hour dynamometer test under varying conditions of speed and load after which they are torn down and each part examined for defects and possible improvements. Many important contributions to the development of aviation motors have been made by government engineers in these experiments.

Tell 'Em You Saw It in the Citizens Radio Call Book Magazine and Scientific Digest

Engineers— We invite you to write us for information that will help you to capitalize on your experience and knowledge by installing—

AMPLION Public Address Systems

We have ready for quick installation group address equipment for both indoors and out for such places as Hotels, Theatres, Factories, Auditoriums, Clubs, Hospitals, Race Tracks, Railroad Depots, County Fairs, Summer Resorts, etc.

Let our engineers help you make more money in this new field of amplification requiring special radio equipment. Briefly speaking we have established something new—

A FREE SERVICE STATION FOR RADIO ENGINEERS

and that is just what it is—a well organized department of our business just to help you. We make no charge for this service; it is freely given with Amplion's compliments and a background of 42 years of success in the acoustic field.

WE HAVE READY FOR IMMEDIATE DELIVERY

SPEAKERS		MICROPHONE (9 1/2 x 9 1/2 x 7)	\$100.00
9" Cono Chassis (9 1/2 x 9 1/2 x 7)	\$15.50	MICROPHONE TRANSFORMER (3x3x3 1/2)	18.00
14" Cono Chassis (24 1/2 x 8 1/2 x 19 1/2)	16.50	AMPLIFIERS	
16" Cono Chassis (26 1/2 x 10 x 22)	17.00	2-Stage (210 tubes in P.P. in last stage (17x14x9))	125.00
UNITS —balanced armature (4x4x3)	8.00	3-Stage (250 tubes in P.P. in last stage (22x17x9))	175.00
A. C. 100 Giant Dynamic Air Column Unit (weight 25 lbs.) (10x8x8)	150.00	MICROPHONE INPUT AMPLIFIER A.C. (14x14 x 9)	110.00
Exciter for A.C. 100 unit (field current supply) (8x 11x6)	30.00	MICROPHONE INPUT AMPLIFIER A.C. (15x17 x 9)	120.00
STEP-DOWN TRANSFORMERS		Amplion Cabinets for Moving Pictures	
type .06 (5x6 1/2 x 7 1/2)	20.00	Cabinets contain 2 turntable electric motors, Amplion electric pick-up and control board for fading one piece of music into another, or making instantaneous switches.	
type .07 (3x3x3 1/2)	10.00	P.M.S. 2 std. (30x40x46)	\$300.00
HORNS		P.M.S. port. (12x32x22)	225.00
42" Trumpet (22" bell) (24x24x44)	25.00	Phono Record Library	200.00
72" Trumpet (74x32x32)	56.00	200 Record (14x14x30)	200.00
10 ft. Air Column (60x 37x46)	200.00	250 Record (14x14x30)	250.00
12 1/2 ft. Column (34x48x 33)	100.00	Especially designed for Non-Synchronous Moving Pictures.	
15 ft. Air Column (57x57 x35)	250.00		

Write for Profitable Amplion Proposition to Competent Engineers We furnish the complete installation or any part of the equipment as desired.

Amplion Corp. of America



133 W. 21st St. New York

Breaks All Records MAGNAFORMER Gets Iceland

THE most Powerful—Greatest Distance Getter—Most Selective and Sweetest Toned Super ever designed, is described on pages 2, 76, 77, 122 and 124 of Spring edition of Citizens Call Book—the NEW 10-tube Super-powerful Shield Grid Magnaformer AC-29, with self-contained complete Power Supply; Phonograph Pick-up; Long and Short Wave Oscillators; Loop or Straight Wire; Outside or Inside Antenna; Dynamic or Magnetic Speaker; AC Shield Grid or all 227 Tubes.

ON this job KFI is a local in New York—WEAF is a local in Los Angeles. Send AT ONCE for FREE 8 page 12 1/2 x 37" pink, part-to-part and wire-to-wire, X-Ray Diagrams and Schematic Drawings showing NEW Volume Control and full and complete wiring instructions and reception verifications of Japan, China, Australia, New Zealand, Argentina, Ireland, England—and—the World's Record Breaker—ICELAND, 10,000 miles away. Write Name on Post Card. Mail at once to

RADIART LABORATORIES 1021 Association Bldg., CHICAGO, ILLINOIS

SHORT WAVE for Foreign Broadcast, Television, Code, The SUBMARINER

attached to your present receiver, either AC or DC, will make this possible. No changes to the wiring of the receiver. Is attached or detached as simple as changing a tube. Like its namesake the submarine, the Submariner is built strong and powerful.

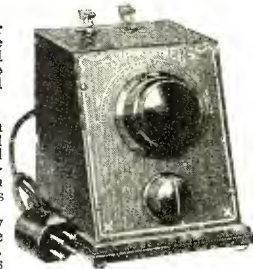

ORIGINAL AND PIONEER

The fact that the Submariner was placed on the market in June, 1926, and been sold in all parts of the world, naturally means that it would be far improved above any other short wave contraption. For instance, the Submariner has been manufactured shielded for over one year. It uses a slow motion dial with a ratio of 32 to 1.

DEALERS everywhere, who sell only quality merchandise and want full protection from the manufacturer, carry the Submariner in stock.

When in some locations satisfactory dealers have not, as yet, been found, we are glad to ship direct when your dealer's name is given.

FOUR MODELS Wave length 20 to 65 meters for battery tubes. coil model, 10 to 160 meters, \$22.50 either for AC or battery tubes. No. 4 coil, 160 to 340 meters, \$2.00 additional. Send anywhere in U. S. upon receipt of price. C.O.D. only in U. S. if \$1.00 accessories order. Canada and some other foreign countries, 60c additional. **ORDER TODAY.** 3443 Fond du Lac Ave. J-M-P Manufacturing Co., Inc. MILWAUKEE, WIS.

REAL SPECIAL OFFER!

Dubilier High Voltage Filter Condensers

(Newest Types, Nos. 902 and 903)

These Dubilier Filter Condensers are tested from 3 to 5 times their rated value, thus assuring a sturdy, scientifically designed product, far excelling the average Filter Condensers now being used.

Widely separated soldering lugs are provided to insure long leakage path and to facilitate heat wiring. Each Condenser brand new and packed in individual carton.

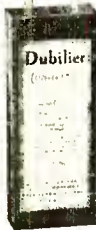

Type No. 902, Rated D.C. Working Voltage 400 V.			
Capacity	List Price	Special	
1	\$2.50 each	\$0.75 each	
2	3.50 each	1.05 each	
4	5.50 each	1.65 each	
Type No. 903, Rated D.C. Working Voltage 600 V.			
Capacity	List Price	Special	
1	\$8.00 each	\$0.90 each	
2	9.50 each	1.65 each	
4	15.00 each	2.85 each	

American Sales Co. 19-21 WARREN ST. NEW YORK CITY

Measurement and Calibration Service

THE laboratories of this organization are now open to the public for engineering services.

Any type of radio measurements or calibration at reasonable prices—see Classified Ad Section for prices on standard measurements. Other prices on request. Your correspondence is invited.

PARKLAND LABORATORIES

1660 East 71st Street CHICAGO

Use a REESONATOR

TRADE MARK

for Volume, Distance, Sharp Tuning

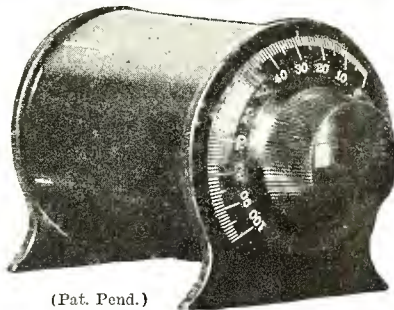

(Pat. Pend.)

\$4.75 COMPLETE

Not a wave trap

and similar radios. When ordering state type of machine on which the REESONATOR is to be used. Equivalent to two extra tubes on your machine. (The REESONATOR is a very attractive instrument made up in a rich, highly polished mahogany brown color.)

What Some of Our Users Say

Gentlemen: We wish to inform you that the REESONATOR we purchased from you some time ago, is meeting with our highest expectations. We have found it of much value in aiding reception, increasing volume, clearness of tone and enabling us to get stations which we otherwise could not hear.

Gentlemen: Last month I bought one of your REESONATORS and I find it to be just as you said. Now, I have no trouble in bringing in far stations, and it cuts through interference good. It makes a big improvement in my set.

Yours truly, N. N. Fisher, Janesville, Wis.

(Signed) Charles Moreau, Albany, N.Y.

We Guarantee Satisfaction Try one for three days at our risk. If not thoroughly satisfied your money will be cheerfully refunded.

F & H RADIO LABORATORIES
Dept. 105, Fargo, N. D.
Ref.: Fargo National Bank Dun's or Bradstreet's
Dealers' and Jobbers' Inquiries Solicited

SEND COUPON NOW
F. & H. RADIO LABORATORIES

Dept. 105 Fargo, North Dakota

...I enclose check or money order for \$4.75 for which send me a Reesonator postpaid.
...Send Reesonator C. O. D.
...Send Dealers' Proposition.
...Please send Literature.
...Send Name of Jobber.

Name.....
Address.....State.....

Classified Advertisements

Advertisements in Classified Section, 25 cents per word each insertion, minimum 10 words, payable in advance. Final closing dates, Aug. 10, for September issue; Oct. 10, for November issue; Dec. 10, for January issue; Feb. 10, for March issue. No display or all caps copy accepted.

ASHLAND Radio Laboratory, Authorized High Frequency Laboratories, Silver Marshall and Scott World's Record Shield Grid Nine Service Station. All makes of sets built, rewired, tested. Guaranteed Radio Service. Reasonable Prices. 411 S. Ashland Blvd. Phone Haymarket 5826. **40 per cent off on all HFL sets.**

WRITE for our latest catalog. Sets, Parts, Kits, Transmitting Apparatus. Radio Apparatus Company, 412 So. Dearborn St., Chicago, Ill.

HEADQUARTERS for New Magnaformer A. C. Superheterodyne. Write for descriptive literature. Nelson Electric Co., 508 S. Dearborn St., Chicago, Ill.

WANTED boys interested in Radio, to write us their names and addresses. We will show you how to build Radio Sets through the Free Course of Instruction offered by the Junior Radio Guild. There is no charge for lessons or material. Just a free course of instruction in the art of Radio. Address A. B. C. Editor, Radio Call Book, 508 S. Dearborn St., Chicago, Ill.

ARE you moving to California? We maintain a luxuriously furnished and appointed Hotel Apartment Building. Just a few minutes from the heart of the city. Quiet and cosy. Complete hotel service. Rates are very reasonable: \$25.00 weekly, \$100.00 monthly, for lovely two-room apartment with every convenience. Inspect our apartments before you locate in Los Angeles. El Cortez, 516 W. 31st St., Los Angeles, California.

MEASUREMENT and Calibration Service. Calibration of Amateur Wavemeters: 1 to 5 Points, \$0.50 per point calibrated; 5 to 10 Points, \$0.40 per point calibrated; 10 to 20 Points, \$0.30 per point calibrated; 20 or more Points, \$0.25 per point calibrated. Blueprints of Curves: 1 Blueprint, \$1.00; 2 Blueprints, \$1.50; 3 Blueprints, \$1.75; 4 Blueprints or more, \$0.50 each; Additional Copies, \$0.20 each. Variable Air Condensers: 1 Per Cent Accuracy, \$0.10 per point calibrated; .1 Per Cent Accuracy, \$0.20 per point calibrated. (Ten points per condenser is usually sufficient). Blueprints of Curves: Same as wavemeter curves. Fixed Condensers: Capacity at 1000 cycles, \$0.25 each. Measurement of Fixed and Variable Condensers: Power Factor, Phase Angle and A. C. Series Resistance. Prices on Request. Intermediate Frequency Transformers. Measurement of Resonant Peak Frequency, \$0.75 each; Frequency response and static amplification characteristic curve, \$1.50 each. (I. F. transformers will not be matched). R. F. Transformers: Pure Inductance, \$1.00 each; Apparent Inductance, \$1.00 each; Distributed Capacity, \$1.00 each; Fundamental Frequency, \$1.00 each; Pure Inductance Matched, \$1.00 each; Apparent Inductance Matched, \$0.50 each. Measurement or Calibration of: Voltmeters, Microvoltmeters, Ammeters, Milliammeters and Microammeters. Any type of laboratory or service equipment built to order. The Parkland Laboratories, 1660-62 E. 71st St., Chicago, Ill.

IN TROUBLE—Does your set perform as it should? Our completely equipped Laboratory is at your service and our charges are no more than any repair shop. Why not have your work done by experts with years of experience and a completely equipped laboratory. Correspondence solicited from those who desire to have sets repaired, tested, changed over, rewired, rebuilt. Estimate will be given in advance on work required. Radio Service Laboratories, 440 S. Dearborn St., Chicago, Ill.

TROUBLE shooting in Superheterodyne Circuits is simplified with the Jeems Super Chart. Practically every known combination is instantly available to locate trouble in this circuit. Costs little—does much. 50c brings the chart, with full directions for its operation. Stamps (U. S.), Coin or Check. Roberts Radio Service, Caxton Bldg., Chicago, Ill.

LEARN the wireless code. Anyone can do it in one evening with the Roberts Short Cut. This system was designed by a former Naval Officer to enable students to master the wireless code in the shortest possible time. No mechanical apparatus needed, just take this short cut and you will be able to read the interesting messages sent from ships at sea and other messages sent in Continental Wireless Code. Failure impossible. The Roberts System costs so little, why not send for it today. 50c Stamps (U. S.), Coin or Check. Short Cut sent postpaid. Roberts Radio, 1775 Caxton Bldg., Chicago, Ill.

ENGLAND offers large market for American Radio Merchandise. We are the Largest Distributors of Radio Merchandise in the British Empire and Continental Europe. Manufacturers desiring to offer their products to this fertile field are requested to communicate with E. F. Heaver, Sales Manager, The Rothermel Radio Corporation, Ltd., 24-26 Maddox St., London, W. 1.

SUPERHETERODYNE for sale. The record breaker Magnaformer 9-8, in beautiful \$200.00 Console (Pierston), has Thordarson B Eliminator. Complete with Tubes, Loop, Dynamic Speaker. \$500.00 value for best offer over \$150.00. Wonderful value. Will demonstrate. Radio Service Laboratories, 440 S. Dearborn St., (Room 675), Chicago, Ill.

WEST COAST representation. Manufacturers of radio products, desiring West Coast Representation invited to write George C. Curtis, formerly sales manager for Gray & Danielson and the Remler Line. Address, Geo. C. Curtis, 222 29th St., Oakland, Calif.

CATALOG—Write for your copy (1929). Full List, Kits, Parts, Accessories. Low Prices. Nelson Electric Co., 508 S. Dearborn St., Chicago, Ill.

CUSTOM built radio sets out perform any other type sets on the market. Superheterodynes hold all records for distance and selectivity. Why not get the best? We build any type set or power amplifier to order. Radio Service Laboratories, Inc., 440 S. Dearborn St., Chicago, Ill.

POSTAGE stamps for collections. Interesting and instructive. We have single stamps and small and large collections for sale. Write for catalog. Metropolitan Stamp Co., Coans Theatre Bldg., 42nd and Broadway, New York City.

ARE you building a house? We will show you how to wire same for Radio. Write us your problems—our service department will show you how. Yaxley Mfg. Co., attention Mr. Sparrow, 9 S. Clinton St., Chicago, Illinois.

THIS CLASSIFIED SECTION IS A PERMANENT ADDITION TO THIS PUBLICATION

IF you have anything special to sell—a small lot to clean out, or a special story to tell, this section will serve your purpose in the cheapest possible way and bring results that will be amazing.

Next issue on sale, September 1st. Four issues yearly, September, November, January and March.

TRY THIS CLASSIFIED SECTION

The Charge Is Small—The Returns Most Gratifying

Save \$2²⁵

Get two radio magazines for the price of one!

“Citizens Radio Call Book” and “RADIO”—a year’s subscription to both magazines for 25c more than the price of a subscription to “RADIO” alone—\$2.75. This great money saving offer is repeated again by popular request. Radio fans in various parts of the world have taken advantage of this saving. The opportunity is yours once more—if you act quickly. Let us send both of these well known magazines to your address for an entire year. If you are already a subscriber you can extend your subscription for another year and save money. These magazines regularly cost you \$5.00 if purchased from a news dealer over a period of a year. Save \$2.25 by subscribing NOW! This is the most liberal magazine subscription offer available. Get in on it before it is withdrawn. Clip the coupon—attach your check, money order or stamps for \$2.75—and get it in the mails today.

The Coupon
Saves you \$2²⁵

—if you mail it now

CITIZENS RADIO SERVICE BUREAU
508 South Dearborn Street
Chicago, Ill.

Here is \$2.75. Send CITIZENS RADIO CALL BOOK
and RADIO, each for a full year to—

Name.....

Street and No.....

City and State.....

Radio's most complete
testing outfit...

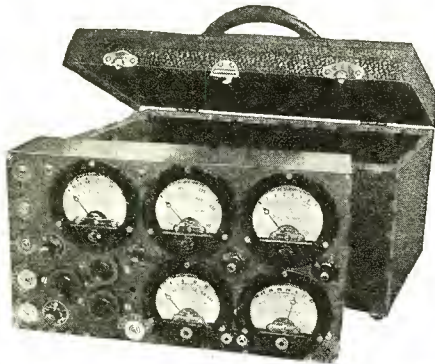

HICKOK

"SEES ALL - TELLS ALL"

RADIO SET TESTER

for every AC and DC Set and Tube

Converts service calls
into sure profits!

THIS Hickok Set and Tube Tester meets every requirement of service dealers who demand accurate, complete testing equipment to safeguard their interests and increase their profits.

Within this single unit is incorporated the necessary apparatus for making any and every test on all types of AC and DC Sets and Tubes; it consists of five meters:

Plate Voltmeter, range 300 and 600 volts

Grid Voltmeter, range 100-0-50 volts

D.C. Filament Voltmeter, range 7.5 volts

Plate Milli-ammeter, 20 and 200 mills

A.C. Filament and Line Voltmeter, 3.3, 15 and 150 volts—Resistance per volt, 1333 ohms

At a slightly extra cost, a serviceable black leather carrying case with a compartment for extra tubes, cables and tools is provided, making the Hickok Tester the logical complete equipment for service work.

A scientifically designed testing device indicating simultaneously on separate meters all the circuit connections in the set and tube. Tests all sets using any type tube.

No buttons to push—no multi-scale meters to read. The correct equipment for store and home service work everywhere

Write for latest Service Manual No. 25, containing valuable Service Data on proper testing methods. Free upon request.

THE HICKOK ELECTRICAL
INSTRUMENT COMPANY

Cleveland / / / Ohio

At Last!

JEEMS SUPER TROUBLE SHOOTER

The Easy Method for Locating Trouble
in Your Superheterodyne

THIS handy chart, comprising 16 symptoms, 130 possible causes, is highly recommended by professional set builders as a valuable asset in the work shop.

Accurate, Sure, Complete, Practical

By Mail, 50c

Roberts Radio Service

Caxton Building

Chicago, Illinois

SAVOY

750 ROOMS EVERY ROOM WITH BATH

IN THE HEART OF
DETROIT

WOODWARD at ADELAIDE

An Atmosphere
of Charm and
Refinement

SAVOY GRILL SELECTED FOODS COFFEE SHOP

SINGLE PER DAY \$2.50 to \$4.00 DOUBLE PER DAY \$4.00 to \$5.50

OF KNOWN QUALITY

The Radio Business Needs Trained Men

Get into it now and make big money!

RADIO, in its amazing growth of the last few years, has passed the doubtful stage. Today there is an assured future for the young man who turns to radio as a career. Vast resources are behind the industry and boundless opportunities are before it. And because radio development has been put on a firmer basis, the demand for *trained men* is stronger than ever.

There is probably no industry in the world where advancement will come faster than to the man who combines executive ability with a *sound technical knowledge* of the science of radio.

In every branch of the business it is the same—designing, manufacturing, selling, servicing. The call is for men who *know*.

Get into radio now. Learn to install sets and to service them. Build a business of your own and be independent. Or, enter the industry as designer, engineer, operator, salesman, as you choose. All you need is training, and there is no better way for you to secure it than the Radio Course of the International Correspondence Schools. Endorsed by radio experts and manufacturers, this course is complete and thorough. It is prepared by men of national reputation in the radio field, and is kept absolutely up to date—abreast of the very latest radio developments.

I. C. S. radio graduates all over the country report that they have increased their salaries and secured more important positions through this splendid training.

If you are interested in things electrical and scientific, if you would like to enter a modern, money-making industry, mail the coupon below for full information about the I. C. S. Radio Course. It will show you what you really *can* accomplish. There is no obligation, of course.

Mail the Coupon for Free Booklet

INTERNATIONAL CORRESPONDENCE SCHOOLS
Box 8317-D, Scranton, Penna.

Without cost or obligation, please tell me how I can qualify for the position or in the subject, before which I have marked an X:

RADIO

- | | |
|---|--|
| <input type="checkbox"/> Electrical Engineering | <input type="checkbox"/> Architect |
| <input type="checkbox"/> Electric Lighting | <input type="checkbox"/> Architects' Blueprints |
| <input type="checkbox"/> Mechanical Engineer | <input type="checkbox"/> Contractor and Builder |
| <input type="checkbox"/> Mechanical Draftsman | <input type="checkbox"/> Architectural Draftsman |
| <input type="checkbox"/> Machine Shop Practice | <input type="checkbox"/> Concrete Builder |
| <input type="checkbox"/> Railroad Positions | <input type="checkbox"/> Structural Engineer |
| <input type="checkbox"/> Gas Engine Operating | <input type="checkbox"/> Chemistry |
| <input type="checkbox"/> Civil Engineering | <input type="checkbox"/> Automobile Work |
| <input type="checkbox"/> Surveying and Mapping | <input type="checkbox"/> Airplane Engines |
| <input type="checkbox"/> Metallurgy <input type="checkbox"/> Mining | <input type="checkbox"/> Navigation |
| <input type="checkbox"/> Steam Engineering | <input type="checkbox"/> Agriculture and Poultry |
| <input type="checkbox"/> Pharmacy | <input type="checkbox"/> Mathematics |

BUSINESS TRAINING COURSES

- | | |
|--|---|
| <input type="checkbox"/> Industrial Management | <input type="checkbox"/> Advertising |
| <input type="checkbox"/> Personnel Management | <input type="checkbox"/> Business Correspondence |
| <input type="checkbox"/> Traffic Management | <input type="checkbox"/> Show Card Lettering |
| <input type="checkbox"/> Accountancy (including C.P.A.) | <input type="checkbox"/> Stenography and Typing |
| <input type="checkbox"/> Cost Accounting | <input type="checkbox"/> English |
| <input type="checkbox"/> Bookkeeping | <input type="checkbox"/> Civil Service |
| <input type="checkbox"/> Secretarial Work | <input type="checkbox"/> Railway Mail Clerk |
| <input type="checkbox"/> Spanish <input type="checkbox"/> French | <input type="checkbox"/> Common School Subjects |
| <input type="checkbox"/> Salesmanship | <input type="checkbox"/> High School Subjects |
| | <input type="checkbox"/> Illustrating <input type="checkbox"/> Cartooning |

Name _____

Address _____



KILLS LINE NOISES

in ELECTRIC RADIOS

Takes out man-made "static" from any electric radio (A. C. or D. C.) or eliminator, caused by motors, elevators, generators, ice machines and other electrical devices. Kills all noises not due to aerial pick-up. Used by engineers of New York Edison Company, General Electric Company, General Motors Corporation, Oil Burner Corporations, etc. SI-LEN-SER makes any electric or any electrified set play as quietly and free from hum as any battery operated receiver.



Works On Any Standard Voltage

The Si-Len-Ser has nothing to do with aerial pick-up or static received over the aerial. Find out whether the disturbing noises are in aerial or power line. To do this, detach the antennae from the aerial binding post and turn your volume control up high. If the same noises are in the loud speaker that were there before then, you need the Si-Len-Ser. If there are no noises in the loud speaker with the aerial disconnected, a Si-Len-Ser is of no value to you.

Endorsed by Radio Press and Engineers

The Si-Len-Ser is a scientific laboratory achievement for the removal of A. C. hum, extraneous noises caused by electric household and power house apparatus and is an essential to every radio owner whose trouble is not due to aerial pick-up.

Sold by All Good Dealers

If your local dealer cannot supply you with a SI-LEN-SER, order from us direct after you have determined that the noises in your set are not due to your aerial. Positively no C. O. D.'s unless accompanied by 20% of the price.

\$12.50

List

Manufactured and Guaranteed by

Trutone Radio Sales Co.,

112 Worth St.
New York City

"It's a TRUTONE Product-It Must Be Right"

QUALITY
DONGAN
PRODUCTS

Everybody Demands Power

—and after you have heard the best you will insist upon Tone Value too.

For Use With UX 250 Tubes

No. 7568	Transformer for full wave rectification using 2 UX 281 tubes to supply B and C power to receiver and power for 2 UX 250 tubes.....	\$13.50
No. 8529	Transformer similar to No. 7568 with the addition of 2 low voltage windings. One for 226 tubes and the other for 227 tubes so that you can build a power amplifier for either radio receiver or phonograph pick-up	\$17.50
No. 6551	Double Choke, for use with above transformers	\$15.00
No. D-600	Power Amplifier Condenser Unit	\$16.50
No. D-307	A Condenser Block, used in connection with D-600.....	\$10.00
No. 1177	Straight Power Amplifier Output Transformer	\$12.00
No. 1176	Same as No. 1177 but of Push-Pull type	\$12.00

Detailed information upon request

Dongan Electric Manufacturing Company
Detroit, Mich.

McDougall at Franklin Street

A
B
TRANSFORMERS of MERIT for FIFTEEN YEARS

Tell 'Em You Saw It in the Citizens Radio Call Book Magazine and Scientific Digest

OUR DRAFTING ROOM

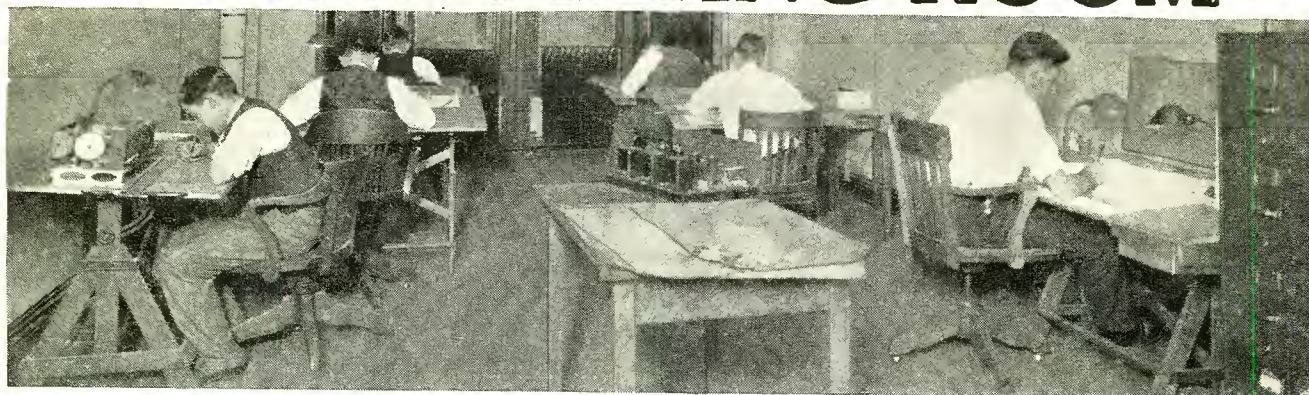

This staff of highly trained draftsmen is continually preparing the most accurate and complete full size blue prints of radio receivers and power packs obtainable. Blue prints are available on all circuits described in the CALL BOOK. Each set of prints is composed of all the necessary drawings prepared in such complete detail and accuracy as to enable an inexperienced builder to duplicate in every respect the receivers built in our laboratory, thus assuring positive success and the greatest satisfaction.

PLEASE ORDER BLUE PRINTS BY NUMBER AND NAME

No. 4	Browning-Drake 5 Tube Receiver using National Impedaformers	1.40	No. 115	Tyrman Amplimax "70" (Shielded Grid) 6 drawings..	1.50
No. 8	15 to 550 Meter Receiver.....	1.40	No. 118	Kaiaas A. C. Equamatic (5 drawings).....	1.50
No. 12	Madison-Moore Super-heterodyne Receiver using 201-A Tubes	1.40	No. 122	Phasatrol DeLuxe 7-Tube T.R.F. Receiver (5 drawings)	1.50
No. 13	Browning-Drake 5 Tube Receiver Using Acme Impedance Amplifier	1.40	No. 123	World's Record Super Ten & Power Pack (6 drawings)	1.60
No. 14	Browning-Drake 4 Tube Receiver Using Audio Frequency Amplification	1.40	No. 124	Hammarlund-Roberts Hi-Q Six.....	1.40
No. 32	Scott "World's Record" Super Eight.....	1.40	No. 125	Silver-Marshall Universal & Power Pack (7 drawings)	1.70
No. 37	Madison-Moore "One-Spot" Receiver.....	1.40	No. 126	St. James Twin Four.....	1.40
No. 44	Melo-Heald Super-heterodyne—11 Tube.....	1.40	No. 129	Remler A. C. Super & Power Supply (9 drawings)....	1.90
No. 47	The "Phasatrol Five" (5 drawings)	1.50	No. 137	Citizens-Birnbach A. C. 4-Tube Receiver (5 drawings)	1.50
No. 48	The Citizens Super Eight.....	1.40	No. 138	Aero Radio-Phone Transmitter.....	1.40
No. 55	30 K. C. Super-heterodyne Receiver.....	1.40	No. 147	Custom-built Model Madison-Moore International One-Spot A. C.—Sub-panel Job (6 drawings)	1.60
No. 56	Improved Browning-Drake	1.40	No. 153	Citizens Shield Grid Short-Wave Receiver.....	1.50
No. 58	"World's Record" Super Nine.....	1.40	No. 162	National Screen Grid Five (5 drawings).....	1.50
No. 64	Aero Seven Tube T. R. F. Receiver (5 drawings).....	1.50	No. 163	Citizens Regenotriac (3 tube A. C.—5 drawings).....	1.50
No. 68	Improved Remler 45 K. C. Super-heterodyne Receiver (5 drawings)	1.50	No. 167	Scott World's Record SG Nine "Power Pack Operated" (4 drawings)	1.40
No. 70	Improved Nine-in-Line (5 drawings)	1.50	No. 172	Remler 1929—115 K. C. SG Super (3 drawings).....	1.30
No. 73	Magnaformer Super-heterodyne Receiver (5 drawings)	1.50	No. 179	Lincoln 8-80 One Spot Super—3 drawings.....	1.30
No. 76	Tyrman Ten (5 drawings)	1.50	No. 184	Citizens Super using HFL I.F. Amplifier—5 drawings	1.50
No. 79	Silver-Marshall High Amplification Super-heterodyne Receiver (5 drawings)	1.50	No. 188	Tyrman Imperial 80—3 drawings.....	1.30
No. 81	1928 Infradyne	1.25	No. 189	Hammarlund-Roberts "Hi-Q" 29 Master, d. c. model—3 drawings	1.30
No. 82	Thompson Super-heterodyne Receiver (5 drawings)....	1.50	No. 190	Victoreen 1929 A.C. Super—6 drawings	1.50
No. 85	Citizens Super Nine (5 drawings).....	1.50	No. 198	Tyrman 72 A.C. Super.....	1.40
No. 86	Thordarson Power Amplifier (5 drawings).....	1.40	No. 208	Hammarlund Roberts A.C. Junior.....	1.30
No. 87	Improved Aero Dyne Six (5 drawings)	1.50	*No. 216	Hammarlund Short Wave Screen Grid Adapter (3 drawings)	1.30
No. 93	Knickerbocker Four (5 drawings)	1.50	*No. 218	Aero International Four Receiver (4 drawings)	1.40
No. 98	Madison Moore International One Spot and Power Pack Baseboard Job (6 drawings).....	1.50	*No. 226	Hammarlund-Roberts Hi-Q 29 Receiver, Master a. c. model (5 drawings).....	1.50
No. 99	Magnaformer 9-8 A. C. (5 drawings)	1.50			
No. 100	Tyrman Super Ten (5 drawings)	1.50			

GRAPHIC WIRING DIAGRAMS

No. 20	Silver-Marshall Improved 7 Tube Super-heterodyne Receiver	\$0.60	No. 182	Halldorson A.C. 56—T. R. F.....	.60
No. 101	World's Record Economy Super 8.....	.60	No. 183	National Short Wave Receiver.....	.60
No. 108	Aero A. C. Seven T.R.F. Receiver.....	.60	No. 185	Silver-Marshall "Coast to Coast" Four.....	.60
No. 119	A-B-C Eliminator for D. C.....	.60	No. 186	Aero 7-29 No. 32 S. G. Receiver.....	.60
No. 134	Nine-in-Line A. C. Operated.....	.60	No. 187	Citizens Special Short Wave Receiver.....	.60
No. 136	Citizens Crystal Receiver.....	.60	No. 195	Junior 2 Tube Receiver.....	.10
No. 140	Citizens Radio Frequency Amplifier.....	.60	No. 196	Aero A.C. Short Wave Converter.....	.60
No. 144	AmerTran Power Pack.....	.60	No. 197	Aero A.C. 21 Chronophase Receiver.....	.60
No. 146	Citizens 115 K.C. Shield Grid Super.....	.60	*No. 199	A.C. R.F. Booster Stage.....	.60
No. 150	Samson Push-Pull Amplifier & Power Supply.....	.60	No. 200	Silver-Marshall Phonograph Amplifier.....	.60
No. 154	Silver-Marshall 4-Tube Shield Grid Receiver.....	.60	No. 202	Silver-Marshall 730 Four Tube Receiver.....	.60
No. 155	Thordarson Shield Grid Power Amplifier.....	.60	No. 203	Remler A.C. Power Amplifier.....	.60
No. 160	Thordarson 210 Power Compact.....	.60	No. 204	Sangamo Push-Pull Lab. Amplifier.....	.60
No. 164	Thordarson 250 Amplifier.....	.60	No. 209	Vee Products A.C. Shield Grid Receiver.....	.60
No. 165	Citizens SG Booster Stage.....	.60	No. 210	Silver-Marshall 6 Tube Receiver (using output choke)	.60
No. 166	Silver-Marshall SG Six (no output choke).....	.60	*No. 213	Junior Four Tube Receiver.....	.10
No. 170	Silver-Marshall SG Super Nine.....	.60	*No. 219	D. C. "B" Supply with Relay and Charger.....	.60
No. 171	Thordarson Dealer's Amplifier.....	.60	*No. 220	Thordarson R-480 power amplifier (171 push-pull)....	.60
No. 174	Sargent-Rayment Seven Receiver.....	.60	*No. 221	Modulated Oscillator.....	.60
No. 178	Silver-Marshall 731 Short Wave Adapter.....	.60	*No. 223	Silver-Marshall 720 a. c. Shield Grid Six.....	.60
			*No. 225	Hollister A.C. Super Eight.....	.60

SCHEMATIC WIRING DIAGRAMS

No. 160a	Thordarson 210 Power Compact.....	.50	No. 196a	Aero A.C. Short Wave Converter.....	.50
No. 164a	Thordarson 250 Power Supply and Amplifier	.50	No. 197a	Aero A.C. 21 Chronophase Receiver.....	.50
No. 165a	Citizens SG Booster Stage.....	.50	*No. 199	A.C. R.F. Booster Stage.....	.50
No. 166a	Silver-Marshall SG Six (no output choke).....	.50	No. 200a	Silver-Marshall Phonograph Amplifier.....	.50
No. 168a	HFL Isotone.....	.50	No. 202a	Silver-Marshall 730 Four Tube Receiver.....	.50
No. 169a	Halldorson SG 5-6.....	.50	No. 203a	Remler A.C. Power Amplifier.....	.50
No. 170a	Silver-Marshall SG Super Nine.....	.50	No. 204a	Sangamo Push-Pull Lab. Amplifier.....	.50
No. 171a	Thordarson Dealer's Amplifier.....	.50	No. 205a	AmerTran Power Amplifier.....	.50
No. 174a	Sargent-Rayment Seven Receiver.....	.50	No. 206a	HFL Special Nine A.C. Super.....	.50
No. 178a	Silver-Marshall 731 Short Wave Adapter.....	.50	No. 209a	Vee Products A.C. Shield Grid Receiver.....	.50
No. 182a	Halldorson A.C. 56—T. R. F.....	.50	No. 210a	Silver-Marshall 6 Tube Receiver (using output choke)	.50
No. 183a	National Short Wave Receiver.....	.50	No. 211a	Magnaformer 1929 A.C. Super.....	.50
No. 185a	Silver-Marshall "Coast to Coast" Four.....	.50	*No. 219a	D. C. "B" Supply with Relay and Charger.....	.50
No. 186a	Aero 7-29 No. 32 S.G. Receiver.....	.50	*No. 220a	Thordarson R-480 power amplifier (171 push-pull)....	.50
No. 187a	Citizens Special Short Wave Receiver.....	.50	*No. 221a	Modulated Oscillator.....	.50
No. 191a	Scott World's Record S. G. Nine "Battery Operated"	.50	*No. 223a	Silver-Marshall 720 a. c. Shield Grid Six.....	.50
No. 194a	Victoreen Duplex Power Amplifier.....	.50	*No. 225a	Hollister A. C. Super Eight.....	.50

*Circuits described in present issue.

Any of the above blue prints will be sent postpaid by return mail upon receipt of the proper amount or they can be obtained from any of the Radio jobbers advertising in this publication. C. O. D. orders not accepted.

CITIZENS RADIO SERVICE BUREAU

508 South Dearborn St.
7th Floor—Chicago, Ill.

A Spring and Summer Entertainer

GEORGE W. WALKER MULTI-UNIT

A Device with a Dozen Uses



- | | |
|----------------------------|-----------------------------------|
| SHORT WAVE RECEIVER | SHORT WAVE ADAPTER |
| REGULAR BROADCAST RECEIVER | REMOTE CONTROL ADAPTER |
| SCREEN GRID PRE-AMPLIFIER | EXTRA STAGE OF R. F. OR "BOOSTER" |
| SINGLE DIAL CONVERTER | AUDIO OSCILLATOR |
| CRYSTAL RECEIVER | RADIO "EXPERIMENTAL" UNIT |
| | WAVE TRAP |
| | WAVE METER |

One of the most unusual radio instruments ever devised. Will perform any individual function of a complete receiver, and in addition may be used for calibrating, testing or checking. Makes a wonderful broadcast receiver, short wave receiver or transmitter. Oscillates violently over the entire scale range from 550 meters down to 20. Uses all tubes 199 to 210 and all voltages, AC, DC or rectified. Nothing like it ever placed on the market before.

The Radio Fan has at his disposal a device which will provide him with something to tinker with for an entire season without performing the same experiment twice. Become acquainted with all the circuits and the way tubes perform under particular conditions.

The Dealer and the service man requires this most valuable instrument for adjusting radio frequency circuits to resonance, providing a beat note or constant frequency oscillation for determining wave length of a particular condenser setting, calibrating a receiver, disposing of trade-ins and obsolete sets by making them up to date by the addition of a R. F. amplifier.

SCREEN GRID R. F. AMPLIFIER

Convert your old battery operated receiver into a modern set by the use of a type 222 DC, battery operated tube.

SCREEN GRID R. F. AMPLIFIER FOR AC SETS

Increase the range of your up-to-date AC receiver by the introduction of an additional stage of high efficiency screen grid amplification. Uses 222 DC tube and a plate supply from your regular receiver.

EXTRA STAGE TUNED R. F.

A booster to be hooked on ahead of the regular receiver. Uses any battery operated tube and will work on any receiver.

SHORT WAVE SCREEN GRID PRE-AMPLIFIER

Experiment with the Multi-Unit connected ahead of your present short wave receiver or adapter. Bring in your real D.X. with more volume.

AC BOOSTER AMPLIFIER

Using the new type 226 AC filament tube. Increases range and flexibility of AC receiver and makes tuning more selective.

SHORT WAVE ADAPTER

Connect to your battery operated receiver. Plugs in detector socket and makes hundreds of short wave stations instantly available. Uses any DC tube, preferably the one which you are now using as a detector.

SHORT WAVE ADAPTION WITH AC RECEIVER

The most efficient AC Short Wave Adapter in the market. Two methods are described to attach this unit quickly and easily to your new AC set.

SINGLE TUBE RECEIVER

A good place to begin. Uses one 201-A tube or other DC type and by the use of headphones this set

will pick up powerful stations from all parts of the country, both broadcast and short wave.

AUDIO OSCILLATOR

Check your receiver for wavelength and calibration. Determine resonance of circuits, test tubes for oscillation and regeneration, neutralizing receivers, balancing condensers, laboratory measurements, short distance transmission and generating a beat frequency for superheterodyne.

There are numerous additional uses, a few of which are wave meters, Loop R. F. Amplifier, single dial AC receiver, remote control for receiver, single control unit for superheterodyne and growler for measuring efficiency of shielding material. By the time an experimenter has exhausted the possibilities of this instrument he will be qualified for a radio engineer.

Consists of the essential parts of an oscillatory circuit, and in addition are plug-in coils, adapter cord and plug, bridging connections, and extra wires along with well detailed instructions for twelve major experiments. Entire unit contained in box 7 1/2 inches by 3 1/2 inches. List.....

\$16.00

AT YOUR DEALER OR MAIL YOUR REMITTANCE DIRECTLY TO FACTORY

GEORGE W. WALKER MFG. CO. 13301 Durkee Avenue CLEVELAND, O.

SERVICE MEN—DEALERS—JOBBER—MANUFACTURER'S AGENTS WANTED

WRIGHT-DeCOSTER DYNAMIC REPRODUCER

"The Speaker of the Year"

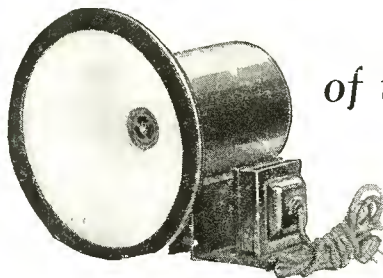

MODEL 107 CHASSIS

BELOW is a letter written by the largest transformer manufacturer in the United States:

"We are now using your dynamic unit in the laboratory for both testing and demonstration purposes and wish to compliment you on its performance. It might interest you to know that every engineer who visits our laboratory has only the highest praise for your speaker".

Very truly yours, THORDARSON ELECTRIC MFG. CO.

Geo. J. Madill ASS'T. SALES MANAGER

Could Any Speaker Have a Higher Recommendation? Descriptive Matter and Prices Gladly Mailed Upon Request

FACTORY REPRESENTATIVES

- | | | | |
|--|---|--|--|
| Electrical Sales Company
261 Franklin St., Boston, Mass. | Mr. Ben J. Apiln
30 Church St., New York, N. Y. | L. P. Clark
1207 Race St., Philadelphia, Pa. | Carl A. Stone Company
407 E. Pico St., Los Angeles, Calif. |
| Electrical Sales Company
9 South Clinton St., Chicago, Ill. | W. C. Laing
Cincinnati, Ohio | Jas. J. Backer Co.
2607-11 Second St., Seattle, Wash. | Mr. W. P. Brush
327 Tilden Sales Bldg., San Francisco, Calif. |
| Mr. G. G. Willison
1913 Pacific Ave., Dallas, Tex. | A-K Sales Corporation
291 So. Elmwood Ave., Buffalo, N. Y. | Church Radio Construction Company
300 Eleventh St. S. W., Washington, D. C. | Gardner Radio and Elec. Corp.
2726 Locust St., St. Louis, Mo. |
| Foreign Representative—Melchior, Armstrong, Dessau Company
116 Broad St., New York, N. Y. | | W. T. Croysdill Sales Co.
619 St. James St., Montreal | B. J. Fitzner Company
159 E. Elizabeth St., Detroit, Mich. |
| | | | Huntington Wholesale Furn. Co.
Huntington, W. Va. |

WRIGHT-DeCOSTER, INC., 2233 University Avenue, ST. PAUL, MINNESOTA

AERO SHORT-WAVE RECEIVER

GERMANY
FRANCE
HOLLAND
ENGLAND
AUSTRALIA
COSTA RICA
JAVA
NEW-ZEALAND

REACHES AROUND THE WORLD

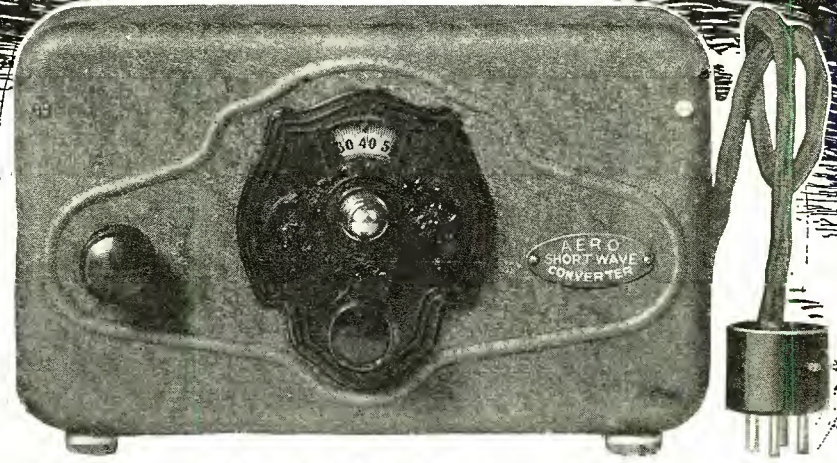

NEW 1929 "AERO-CALL" Short Wave Converter Factory-Built, Ready to Plug Into Your Present Radio Set

Illustration shows the new Aero 1929 Converter—a compact factory-built short-wave adapter equipped with special short-wave coils. It is designed for both A.C. and D.C. Sets. Operates perfectly on all sets without motorboating, by an auxiliary filter system control, an exclusive feature (patent applied for). It can be plugged into any regular radio set. This amazing radio instrument now makes it possible for you to reach 'round the world—England, France, Germany, Holland, Australia, Panama, Spain, Java and many foreign stations are some that are tuned in regularly on short wave. Permits you to enjoy international programs and many others from coast-to-coast that your regular receiver cannot get. What a thrill it is to plug this into a tube socket on your regular set and instantly be in another world! No change or wiring required. All complete, ready to operate, tubes and coils hidden, no apparatus in sight, except the neat, golden-brown, compact metal cabinet in crackle finish. Size 9x5½x2½ in.

The only converter we know of that really works on all sets. Two models—A.C. and D.C. Order from your dealer now, or remit \$25.00 direct, giving dealer's name. Free booklet on request. Dealers and Jobbers write for literature and prices.

Model A, for A.C. sets.....\$25.00
Model D, for D.C. sets.....

AERO SHORT WAVE KITS

The world is at your instant call with Aero Short-Wave Receivers and Transmitters. The thrill of getting the far-off places of the earth, expeditions, ships at sea, transcontinental airplane messages and hearing musical programs and code messages from foreign countries is something you will enjoy tremendously. It's something new, something different. You can get this with an Aero Short-Wave Receiver. Astound yourself and your friends. These amazing hidden sides of radio reception are unknown to many, but thousands of fans are getting a bigger "kick" out of radio by their use.

You don't know radio until you get a taste of real short-wave reception with an Aero Standard or International Receiver. Try it yourself—you'll be happily surprised. Order an Aero kit today and you'll have a new interest and a new lease on life.

NEW 1929 AERO COILS

Since January 1st, 1929, many short-wave enthusiasts and "hams" have had difficulty in getting anywhere with their old sets. Aero was first to come out with new receiver and transmitter coils to meet the new conditions. The new 1929 Aero coil kits are now ready. Bring your old sets up to date. Get these new coils now and get everything that's in the air. The new Aero Listening Monitor is another 1929 product that is a necessity with "hams." Send for the new 1929 supplement and the Big Green Book. Don't miss out on these newest developments.

AERO PRODUCTS
INCORPORATED
Dept. 1039

4611 E. Ravenswood Ave., Chicago, U. S. A.

AERO Users Tune In on the World

List of foreign short-wave stations received by Richard H. Addison, 29 Armandine St., Boston 24, Mass., from October 1st to December 12th, 1928, using Aero Short Wave Coils:

5SW—Chelmsford, England; 5XX—Dan-very, England; PCJJ—Eindhoven, Holland; PCLL—Kootwijk, Holland; CJRX—Winnipeg, Manitoba, Canada; 2ME—Sydney, Australia; 3LO—Melbourne, Australia; ANH—Bandoeng, Java; 9RH—Heridea, Costa Rica; IYB—Auckland, New Zealand, etc.

England, France, Germany, Holland and Australia!

List of foreign stations received by G. E. Morcroft, Jr., Bellevue, Pa., on set using Aero Coils:

5SW—England; PCLL and PCJJ—Holland; AFK—Germany; FW—Paris, France; ANH and ANP—Java; GBS—English Trans-Atlantic phone; 2ME—Sydney, Australia; 3LO—Melbourne, and 5CL—Adelaide, Australia, etc.

Gets South America and Honolulu

Under very unfavorable conditions, I have heard phone stations as far away as South America. Buenos Aires comes in great. I have had no trouble at all in getting KGU at Honolulu and PWX, Cuba. ARTHUR W. HOWARD, Boulder, Colo.

Gets Europe and South America

I desire to inform you that I have completed the Aero Short Wave Receiver and I am very well pleased with the results. I have already received European stations and South American stations, and practically every district in the United States, including Canada.
F. W. JACOBY, Cashier.

Hears "Big Ben" Strike In London

Have heard, so far, 5 SW at Chelmsford, England, on 24 meters on March 21, 22 and 23, between six and seven o'clock E. S. T. I positively heard "Big Ben" striking twelve o'clock G. M. T. on these three nights.
HARRY MAYS.

6,000 Mile Musical Reception

All of the receivers that I have built using your coils have been receiving musical programs from Eindhoven, Holland, on 30.2 meters and several times with loud speaker volume at four o'clock p. m., eastern standard time. I suppose that this reception distance is about 6,000 miles.

CHARLES WIGGINS,
Ancon, Canal Zone, Panama.

Aero Coils Are the "Berries"

Last night I got up about 2 a. m. and before the sun rose I logged 22 sixes, 5 BZ's, 2 F's, 3 A's, 2 Z's and several others whose call I mixed up or lost. All of these signals were on the 40 band and all were at least R4-5.

I really think your coils are the berries and all the boys that have seen the set are crazy about it.

Vy 73a es Cu agn.
2 AYJ (Bob Foucel, Op.)

England Every Afternoon

We have received your International Converter and we are well pleased with it. We get England every afternoon between 5 and 6 with a lot of volume.
MATHIS & BARKER.

Aero Coils on Byrd Expedition

Aero coils and parts are used in the short wave apparatus used by Commander Byrd on his Antarctic expedition.

Aero Products, Inc.,
4611 E. Ravenswood Ave., Dept. 1039, Chicago.

Send me one of your new 1929 "Aero-Call" Short Wave Converter Boxes, ready to plug into my set. Enclosed is remittance for \$25.00.

Your Name.....
Street and Number.....
City..... State.....
State whether A.C. or D.C. Model is desired.....
Name and Address of Dealer or Jobber.....

Order Your AERO Products From Short-Wave Headquarters . . .

*Barawik Always
Has It In Stock!*

BARAWIK was first to establish a special short-wave department for its customers, and today Barawik is known the world over as "short-wave headquarters."

If you haven't experimented with short-wave yet, now is a good time to begin. It is a most fascinating pastime—you get a real thrill out of communication with foreign countries and distant points not reached by regular radio receivers.

Ordering your Aero products by mail from Barawik assures you quick service, as we are located only a short distance from the Aero factory—and we keep complete stocks on hand. Our central location gives quicker service to every point—much quicker than you can get elsewhere.

Get your Aero coils, kits, converters, transmitters and parts here. You will be agreeably surprised at the fast service, extra free blueprints, instructions, etc., and the business-like manner in which your needs will be supplied.

New 1929 Coils, Transmitters, Etc. for the New S. W. Bands

On January 1st, 1929, the federal government put into effect a new policy regarding short-wave transmission and reception. The new 1929 Aero receiving and transmitting coils, for the 10, 20, 40, 60, 80 and 100-meter bands will bring your present equipment up to date. Get them from Barawik and keep your equipment modern.

You Save Money Here on Thousands of New Items

The Spring and Summer 1929 edition of Barawik's Big Radio Guide is crammed full of many new money-saving bargains that you will need constantly. Besides a full line of radio products, parts, accessories, kits, etc., you will find auto tires, tubes and accessories, electrical fixtures, lamps, appliances, wiring material, sporting goods, tennis, golf and baseball supplies, outing, camping and touring equipment, novelty furniture, portable radio sets and phonographs, radio-phonograph combinations, television supplies and household specialties, including vacuum cleaners, washing and sewing machines, electric massager-exercisers, electric stoves, flashlights, electric water supply systems, motors, electric fans, garden hose, spraying outfits and hundreds of items that are in everyday need in most homes.

If you haven't received your copy of this money-saving book yet, write for it today. Use the handy coupon below now! Free to readers of the Call Book.

The Barawik Co.

33-A Canal Station
Chicago, Ill.

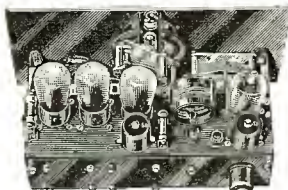

**Aero International
Short Wave Receiver**

**Screen
Grid**

This is the first short wave receiver designed exclusively for the reception of broadcast on low waves. Broadcast reception on short waves is remarkably clear and free from static. Programs come in from greater distances with the utmost simplicity of control. Complete kit includes everything necessary to assemble the set.

Aero Kit No. 8—List Price.....\$55.30

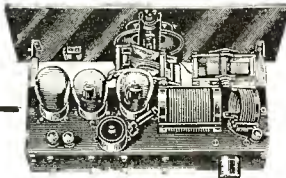

**Aero Standard
Short Wave Receiver**

This three-tube short wave receiver utilizes a circuit which has been proven by years of excellent results in the hands of amateur operators. The audio transformers are of the same type as are used in broadcasting stations, assuring excellent tone quality even when receiving programs from a great distance.

Aero Kit No. 10 for A. C. Tubes—List Price.....\$49.95
Aero Kit No. 11 for D. C. Tubes—List Price..... 49.95

BARAWIK CO., 33A Canal Station, Chicago, Ill.

Dear Sirs:

Please send me your Big Bargain Book showing the Aero Products line and the many bargains in radio goods, sporting goods and the new lines for 1929 that you advertise.

Name.....

Address.....

City..... State.....

ANNOUNCEMENT

After March 1st Radio Service Laboratories Will Be Located in Our Larger and Newly Equipped Laboratory at 440 South Dearborn Street, Chicago

THIS highly efficient organization with trained service men, together with a completely equipped laboratory, is at your disposal for repairing, testing and advice on all types of radio receivers, battery eliminators and power units. Our experience in this field has helped all our clients to enjoy better and continuous radio reception. All laboratory instruments used in testing and repairing are modern and up to date, insuring rapid and accurate location of trouble involved in your receiver.

BUILDING, REPAIRING and TESTING

Power Amplifiers

Public Address Systems

AC Receivers

DC Receivers

**Electrical Phonograph
Equipment**

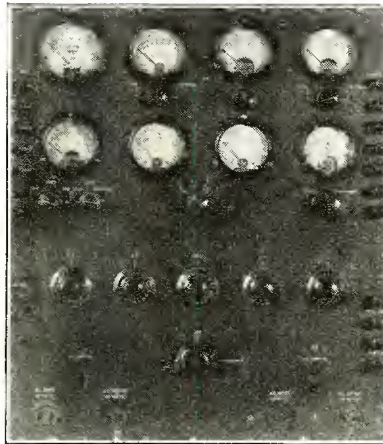

One of our newly designed testing panels

Testing Equipment

Dynamic Speakers

Short Wave Converters

Battery Eliminators

**Short Wave Telephone
and Telegraph
Transmitters**

Transformers, Coils and Condensers Matched

If you are unable to personally deliver the receiver or unit you wish to have repaired, securely pack it in a strong box with plenty of cushioning material such as excelsior, and ship it to us via American Railway express prepaid. It is not necessary to ship the cabinet or accessories. In order that you may safely ship your receiver to us for repairs, we can supply you with a strong fabricated carton, including the required amount of packing, sealing tape, wrapping paper and rope at a cost of \$1.00. This carton conforms to the construction requirements of the Consolidated Freight Classification, a resistance of 200 pounds per square inch and a gross weight limit of 65 pounds.

OUR SERVICE IN YOUR HOME

WE have a corps of specially trained service men ready to call at your home to service your radio receiver and accessories. These service men have been carefully trained in this laboratory to be familiar with all types of receivers and power units. Each service man is completely equipped with laboratory instruments so that he may in a scientific way rapidly locate and correct the defects in your radio.

RADIO SERVICE

440 South Dearborn Street

Formerly Located at 508 South Dearborn St.

Tell 'Em You Saw It in the Citizens Radio Call Book Magazine and Scientific Digest

GUARANTEED SERVICE

By the Largest and Most Up to Date Radio Service
Station in America

BECAUSE the largest staff of trained service repairmen and engineers are at your service, you can be assured at all times of the most careful and competent work. This is proven by the large numbers of sets shipped to us for service from every state in the U. S., Canada, Alaska, and Mexico. We will repair, test, or design any type of receiver you may desire. Being specialists in this field we are in an excellent position to rebuild your present receiver and bring it up to date. Any receiver or power device repaired is guaranteed to give satisfaction and be free from electrical and mechanical defects.

REMEMBER

the confidence of many leading manufacturers has been placed in this laboratory. The Radio Service Laboratories will give to you the same conscientious service that the manufacturer himself would give you. We are thoroughly familiar with every make of receiver, power unit and radio accessory, therefore, regardless of how old or new, or what type receiver you wish serviced we can make the necessary repairs, incorporate many of the later developments, together with replacing any defective part.

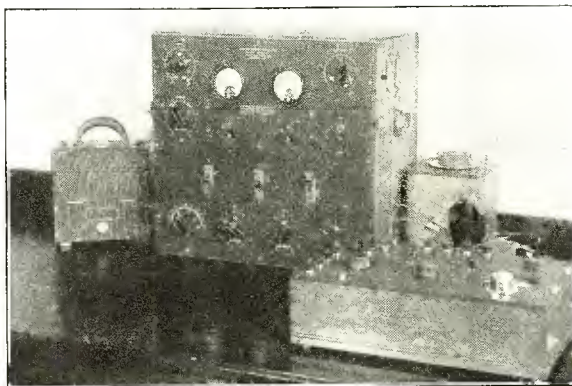

Testing equipment for matching transformers, coils,
and condensers

WE SPECIALIZE

in servicing all receivers illustrated in the Citizens Radio Call Book. If you have constructed any of these receivers and are not obtaining satisfactory results, let us give you an estimate for putting the set in first class condition together with incorporating all the latest developments. It is more practical and wise to bring your problems here than to some irresponsible radio man who is unfamiliar with the merchandise you wish serviced. This is an era of specialized effort and our charges are no more than you would pay for inferior workmanship.

KIT and PARTS—LABORATORY-TESTED

at

ATTRACTIVE PRICES

LET this laboratory be of service in advising you as to the results you will obtain from any kit or part furnished by us. As an example there are a great number of good receivers to build and from these one will be best suited for your requirements and location. This service is of great value to you in selecting a receiver that will give the most satisfaction.

The Radio Service Laboratories is now operated under the personal supervision of *Arthur Elkins*, President, and *R. W. Weisbach*, Secretary-Treasurer. We are now offering unequalled service and invite your patronage.

LABORATORIES, Inc.

Telephone Harrison 2870

Chicago, Illinois

Tell 'Em You Saw It in the Citizens Radio Call Book Magazine and Scientific Digest

Index to Advertisers

A		G		Q	
Acme Electric and Mfg. Co., The.....	133	General Radio Co.....	136	Questionnaire	117
Aero Products, Inc.....	154	Gray & Danielson Mfg. Co.....	42	R	
Aerovox Wireless Corp.....	118-140	H		Radiall Company	131
Allen-Rogers-Madison Co.	110-139	Hammarlund Mfg. Co.....	123	Radiart Laboratories	125-134-147
Allied Radio Corp.....		Hammarlund-Roberts, Inc.	23	Radio Amateur Call Book.....	146
.....13-109-110-119-125-134-138-142		Henry, Hotel	134	Radio Association of America.....	25
Alvon Radio Laboratories.....	131	Hickok Electrical Instrument Co.....	150	Radio Institute of America.....	33
American Sales Co.....	147	High Frequency Laboratories.....	113	Radio Parts Co.....	110
American Transformer Co.....	37	Howard Radio Co.....	Second Cover	Radio Products Co., The.....	136
Amplion Corp. of America.....	147	I		Radio Service Laboratories, Inc.....	
Arcturus Radio Co.....	118	Insuline Corp. of America.....	125110-142-145-156-157	
Aston Cabinet Manufacturers.....	129-159	International Correspondence Schools.....	151	Radio Service & Supply Co.....	145
B		International Resistance Co.....	142	Raytheon Mfg. Co.....	126
Barawik Co., The.....	155-160	J		Readrite Meter Works.....	115
Benjamin Electric Mfg. Co.....	126	J. M. P. Mfg. Co., Inc.....	128-147	Roberts Radio Service.....	119-150
Benson-Allen, Inc.....	128	K		Robertson-Davis Co., Inc.....	43
Birnbach Radio Co.....	120	Karas Electric Co.....	141	S	
Braun Co., W. C.....	1-107	Knapp Electric, Inc.....	31	Samson Electric Co.....	127
C		L		Sangamo Electric Co.....	Insert 32-33
Came Radio Co.....	110	Lincoln Radio Corp.....	5	Savoy, Hotel	150
Carter Radio Co.....	137	Lundquist Tool & Mfg. Co.....	121	Set Builders Supply Co.....	110
CeCo Mfg. Co., Inc.....	11	Lynch Inc., Arthur H.....	129	Shanklin Mfg. Co.....	119
Central Radio Laboratories.....	128	M		Silver-Marshall, Inc.....	106
Chicago Radio Apparatus Co., Inc.....	109	Magnavox Co., The.....	41	Sonatron Tube Co.....	Fourth Cover
Chicago Salvage Stock Store.....	108	Midwest Radio Corp.....	Third Cover	Supreme Instruments Corp.....	21
Chicago Solder Co.....	135	Miller-Welles Co.	29	Surplus Radio Co.....	141
Citizens Radio Service Bureau (Blue Prints)	152	Mississippi Valley Radio Co.....	141	T	
Citizens Radio Service Bureau (Subscrip- tion Offers)	111-122-132-143-149	Montclair, Hotel	138	Thordarson Electric Mfg. Co.....	7
Clarostat Mfg. Co., Inc.....	113	Muter Co., Leslie F.....	17	Thorola Radio Products.....	113
Classified Advertisements Page.....	148	N		Townsend Laboratories	119
Cornish Wire Co.....	130	National Co., Inc.....	137	Trutone Radio Sales Co.....	151
D		National Radio Institute.....	3	U	
Deutschmann Corp., Tobe.....	4	Nelson Electric Co.....	139	Underground Aerial Products.....	15
Dongan Electric Mfg. Co.....	151	Newell Pharmacal Co.....	142	V	
Drake Hotel, The.....	135	New England Mills Co.....	138	Vee Products	128
Dubilier Condenser Corp.....	130	New Way Spray Gun Co.....	139	W	
E		O		Walker Co., The Geo. W.....	27
Eby Mfg. Co., Inc., The H. H.....	120	Ohmite Mfg. Co.....	138	Walker Mfg. Co., George W.....	153
El Cortez Apartments.....	144	P		Webster Company	115
Electrad, Inc.	9-116	Parkland Laboratories	147	Wedel Company	109
Elkon, Inc.	19	Piccadilly Hotel, The.....	141	Western Radio Mfg. Co.....	
Excello Products Corp.....	121	Polk, J. L.....	119108-110-126-136-143	
F		Polymet Mfg. Corp.....	114	Weston Electrical Instrument Corp.....	2
F & H Radio Laboratories.....	147	Potter Co., The.....	112	Wright-DeCoster, Inc.....	153
Ferranti, Inc.	123	X		Y	
Formica Insulation Co.....	125	X. L. Radio Laboratories.....	124	Yaxley Mfg. Co.....	127
Fort Shelby Hotel.....	140	Y			
Franklin Institute	125				
Frost, Inc., Herbert H.....	124				

Distinctive Radio Cabinets by Aston

*For those who are pleased with
only the finest*

THE name **Aston** is now recognized as the hallmark of supreme excellence in cabinet craftsmanship. For in **Aston Cabinets** are combined a basic soundness of construction and a beauty of design that have inevitably brought the highest recognition. The cabinets here illustrated are a fitting piece to occupy the most handsomely appointed room. No. 223 and No. 218 are only two of the attractive cabinets you will find in our new catalog—write for it today.

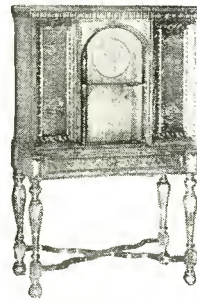

No. 223—Open

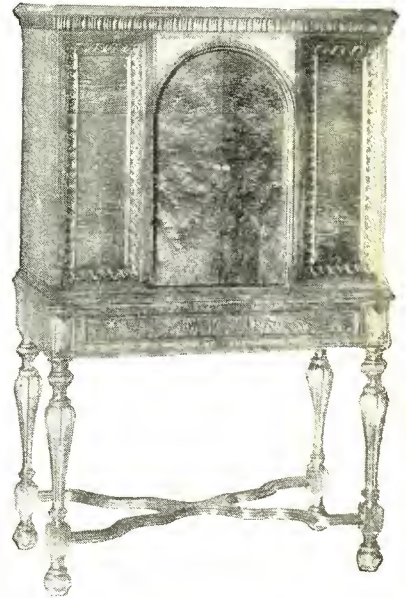

No. 223—Closed

One of our latest Aston Radio Cabinets, of 100% Burl Walnut front, together with the Satinwood overlay topping the doors. As the doors are opened, they reveal the richness of the set panel 13" wide for dials and the French polychromed speaker grille with a dash of color.

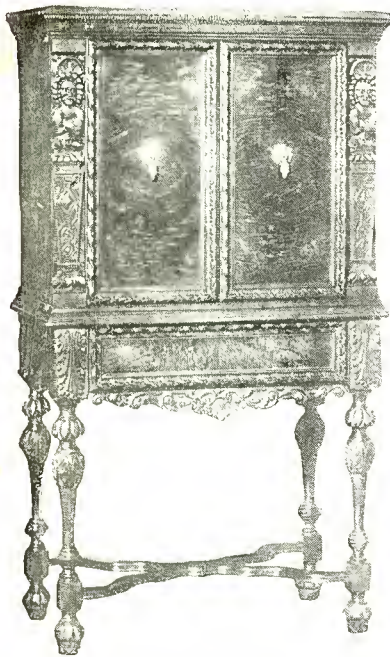

No. 218—Closed

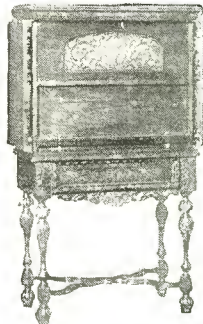

No. 218—Open

A staunchly built Aston Radio Cabinet, of select five ply Walnut. Doors of beautifully figured matched Walnut which fold back against the sides. Carved legs joined with a pleasingly designed stretcher.

DEALERS and SET-BUILDERS

Write for our new 1929 catalog. It will give you full details about these beautiful cabinets, as well as description of many other pleasing ASTON models. Our attractive discounts will interest you.

ASTON

CABINET MANUFACTURERS

1223-1229 West Lake Street
Chicago, Illinois



*Distinctive Originality
in Design of
High Grade Radio Cabinets*



If you are in this vicinity **COME IN** and see our new, complete display

Barawik - the Old Reliable RADIO SERVICE

**Send to Barawik for the
George W. Walker Multi-Unit**
Described in This Issue



A DEVICE WITH A DOZEN USES

- | | |
|--|---------------------------|
| Short Wave Receiver | Single Dial Converter |
| Short Wave Adapter | Audio Oscillator |
| Regular Broadcast Receiver | Radio "Experimental" Unit |
| Screen Grid Pre-Amplifier | Crystal Receiver |
| Remote Control Adapter | Wave Trap |
| Extra Stage of R. F. or "Booster" Wave Meter | |

One of the most unusual radio instruments ever devised. Will perform any individual function of a complete receiver, and in addition may be used for calibrating, testing or checking. Makes a wonderful broadcast receiver, short wave receiver or transmitter. Oscillates violently over the entire scale range from 550 meters down to 20. Uses all tubes from 199 to 210 and all voltages, AC, DC or rectified. Nothing like it ever placed on the market before.

The Radio Fan has at his disposal a device which will provide him with something to tinker with for an entire season without performing the same experiment twice. Become acquainted with all the circuits and the way tubes perform under particular conditions.

The Dealer and service man requires this most valuable instrument for adjusting radio frequency circuits to resonance, providing a beat note or constant frequency oscillation for determining wave length of a particular condenser setting, calibrating a receiver, disposing of trade-ins and obsolete sets by making them up to date by the addition of an R. F. amplifier.

the one which you are now using as a detector.

Short Wave Adapter of AC Set

The only adapter on the market which will allow you to use AC plate supply on the short waves. Works something wonderful.

Single Tube Receiver

A good place to begin. Uses one 201-A tube or other DC type and by the use of headphones this set will pick up powerful stations from all parts of the country, both broadcast and short wave.

Audio Oscillator

Check your receiver for wavelength and calibration. Determine resonance of circuits, test tubes for oscillation and regeneration, neutralizing receivers, balancing condensers, laboratory measurements, short distance transmission and generating a beat frequency for superheterodyne.

There are numerous additional uses, a few of which are wave meters. Loop R. F. Amplifier, single dial AC receiver, remote control for receiver, single control unit for superheterodyne and growler for measuring efficiency of shielding material. By the time an experimenter has exhausted the possibilities of this instrument he will be qualified for a radio engineer.

Consists of the essential parts of an oscillatory circuit, and in addition are plug-in coils, adapter cord and plug, bridging connections, and extra wires, along with well detailed instructions for twelve major experiments. Entire unit contained in box 7½ inches by 5 inches by 3½ inches. Wt., 5 lbs. 3T510—List.....

\$16.00

Screen Grid R. F. Amplifier

Convert your old battery operated receiver into a modern set by the use of a type 222 DC, battery operated tube.

Screen Grid R. F. Amplifier for AC Sets

Increase the range of your up-to-date AC receiver by the introduction of an additional stage of high efficiency screen grid amplification. Uses 222AC tube and a plate supply from your regular receiver.

Extra Stage Tuned R. F.

A booster to be hooked on ahead of the regular receiver. Uses any battery operated tube and will work on any receiver but a reflex. Increases range of set at least 1000 miles.

AC Booster Amplifier

Similar to above but using the new type 226 AC filament tube. Increases range and flexibility of AC receiver and makes tuning more selective.

Short Wave Adapter

Connect to your battery operated receiver. Plugs in detector socket and makes hundreds of short wave stations instantly available. Uses any DC tube, preferably

Usual Discounts to Dealers, Set Builders, Customers

Other Radio Bargains

Here you will find the most complete line of factory-built quality radio sets, dynamic and other speakers, a big assortment of radio cabinets and furniture, tubes, batteries, accessories and parts and kits for Silver-Marshall, Remler, Aero, Carter, Karas, Tyrman, Lincoln, H.F.L., Hammarlund, Magnaformer, National and all the famous names in Radio.

Besides a complete radio line, you can get here your tires, tubes, auto supplies, camping equipment, outing clothing, golf supplies, sporting goods, electrical and wiring material, lighting fixtures, phonographs, Christmas gifts, toys, vacuum cleaners, household and electrical appliances and hundreds of other every-day needs—all at big savings.

Do your radio shopping here by mail or in person. You'll be well treated, have a larger assortment from which to choose, and save money in the bargain.

Out-of-town customers are just as welcome as those in Chicago. If you can't visit us personally, send for our big Catalog and Buyers' Guide at once.

BARAWIK CO., 33 Canal Sta., Chicago

Please send me the new Spring and Summer edition of the big free Barawik Radio Guide, Catalog and Radio Encyclopedia at once, showing the many new bargains you offer, including new departments and offers on the Multi-Unit and Magnaformer.

Your Name.....
Address.....
City..... State.....

**Get Your New MAGNAFORMER
A.C. 29 Kits from Barawik**

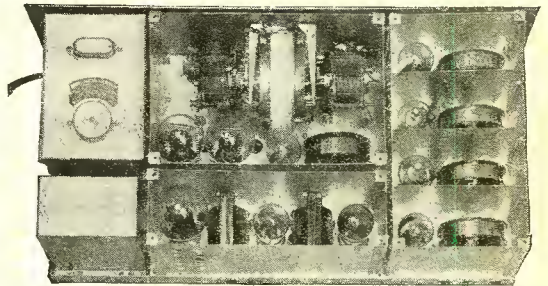

**Breaks All Records—Magnaformer
Gets Iceland!**

The Most Powerful—Greatest Distance Getter—Most Selective and Sweetest Toned Super ever designed, is described on pages 2, 76, 77, 122 and 124 of Spring edition of Citizens Call Book—the NEW 10-tube Super-powerful Shield Grid Magnaformer AC-29, with self-contained, complete Power Supply; Phonograph Pick-up; Long and Short Wave Oscillators; Loop or Straight Wire; Outside or Inside Antenna; Dynamic or Magnetic Speaker; Shield Grid or all 227s.

Included with each kit ordered is a FREE 8-page 12½x37" pink, part-to-part and wire-to-wire, X-Ray Diagrams and Schematic Drawings showing NEW Volume Control and full and complete wiring instructions and reception verifications of Japan, China, Australia, New Zealand, Argentina, Ireland, England—and—the World's Record Breaker—ICELAND, 10,000 miles away.

3T5550—Complete Kit. List Price.....\$184.90

Usual Discounts to Dealers, Set Builders, Customers

12-HOUR SERVICE

The Barawik Co.

33 Canal Station, Chicago, Ill., U. S. A.

FACTORY TO YOU—SAVE 50%—COMPARE WITH COSTLIEST OUTFITS BEFORE YOU BUY

Enjoy a powerful new **Miraco** ^{set or complete outfit} **30 DAYS FREE** AC Electric or Battery

3 Year Guarantee

Get Our Send No Money 9th Anniversary Offer!



Built like, Looks like, Performs like a \$200 set

Marvelous new 3-year guaranteed, lighted 1-dial control. All metal super shielded Miraco set, removed from cabinet. Front switch, phonograph pick-up connection and all latest features. Built in power section on AC models.

The Latest, Finest and Costliest Construction

\$49⁸⁸
COMPLETELY ASSEMBLED

8 tube ~ one dial Electric Lighted

MIRACO

TRADE MARK REGISTERED

CATHEDRAL TONED, SUPER SELECTIVE, POWERFUL DISTANCE GETTERS

Celebrating its 9th successful year, America's big, old, reliable Radio Corporation springs a genuine sensation in high-grade sets. With its latest, Super-powered, 1-dial Miracos—the All Electric wholly self-contained, hum-free, AC-8 and AC-9, using AC tubes or the new 8-tube models

hum-free operation, tremendous "kick" on distant stations and razor-edge selectivity—with its costly sturdy construction, latest features, including phonograph pick-up connection, ease of tuning, beauty, and economy—a Miraco will make you the envy of many whose radios

BIG DISCOUNTS
Exclusive Territory to User-Agents on **BATTERY OR AC ELECTRIC OUTFITS**

for batteries or Eliminators—you are guaranteed values and savings unsurpassed in the fine set field.

Compare a Miraco with highest-priced radios, for 30 days in your home. Surprise and entertain your friends—get their opinions. Unless 100% delighted, *don't buy it!* Return everything—the complete outfit—at our expense. Your decision is final—absolutely!

Only exceptionally fine radios, of the very latest approved type, at rock-bottom prices, could possibly back up so liberally unconditional a guarantee. Send coupon now for **Amazing Special Factory Offer!**

Don't Confuse with Cheap Radios With its rich, clear Cathedral tone,

Miraco Outperforms 'em All In Chicago On the Miraco Unitaine, to start with, will say: I got to date 61 stations outside of Chicago, from the Pacific Ocean to the Atlantic Ocean, and from Anchorage, Alaska, to the Gulf of Mexico, and I tried the set with 3 different antennas. That is an outside aerial 152 feet, an inside aerial 20 feet, and

light socket. I want to say that your set does outperform the other sets I have. I put it up against a World Record Super 9 and beat that one. Then I put it up against a (name's expensive make), and beat that one. Next I put it up against a Neutrodyne and beat that one. HARRY KOPP, 6555 South Peoria Street, Chicago, Illinois.

MIDWEST RADIO CORPORATION, 531-RM Miraco Building, Cincinnati, Ohio

BEAUTIFULLY ILLUSTRATED CATALOG, AMAZING SPECIAL FACTORY OFFER, TESTIMONY OF NEARBY USERS—All the proof you want—of our honesty, fairness, size, financial integrity, radio experience and the performance of our sets—including Amazing Factory Offer—sent with catalog.



Free!

MIDWEST RADIO CORPORATION
Pioneer Builders of Sets—9th Successful Year
531-RM Miraco Bldg., Cincinnati, Ohio

THIS COUPON IS NOT AN ORDER

WITHOUT OBLIGATION, send free catalog, Amazing Special Factory Offer, testimony of nearby users, etc. User Agent Dealer
 Check here if interested in an EXCLUSIVE TERRITORY PROPOSITION
NAME ADDRESS

NEW LOW FACTORY PRICES
SAVE 50%

Wide Selection of Beautiful Cabinets
AC or Battery Sets
30 DAYS HOME TRIAL



A popular walnut Hi-Boy Console, with drop-leaf desk. Beautiful two-tone finish. Rare bargain!



Beautifully graceful Spinet console, genuine two-tone walnut. Choice of speakers. Also comes in Electric Phonograph-Radio Combination.



A new-type arm-chair console. Genuine walnut. Very pretty. Low priced. Electro-Dynamic or Magnetic-Power Speakers.

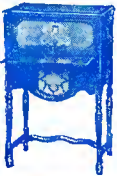

At right, a Lo-Boy console, walnut finish, that costs little. A gem!



Above, popular inexpensive combination. Set on Table Speaker (sold separately).



Metal or wood compact style cabinets. Wood cabinets in walnut or new shaded silver-chrome finishes. Cathedral Electro-Dynamic or Magnetic-Power Speaker to match!



AC-8—\$71.50

Unbeatable value in a 3-year guaranteed Super Shielded Metal Cassis.



Also New, More Powerful Battery Sets

The newest and latest in battery operated sets, designed with same advanced features used in electric sets! Same wide choice of cabinets. Highest quality, amazingly low priced!

SONATRON

THE WORLD'S LARGEST RADIO TUBE LINE



Only
under this
Label—
a radio tube
for every socket

44 DISTINCT TYPES

The World's Largest Radio Tube Line contains a tube for every need in modern radio:

AC TUBES

X226, Y227, X222AC, X171AC, X401

POWER TUBES

X112, X112A, X171, X171A, X210, X250

GENERAL PURPOSE TUBES

X201A, X222, X200A, X201B, X240

RECTIFYING TUBES

SH85, X280, X281, X213, X216B

DRY CELL TUBES

199A, X199, V199, X120, V120, 120A

—and many others

UNDER no other label will you find a radio tube for every radio need . . . for no other manufacturer offers all of the tubes which make up The World's Largest Radio Tube Line. Only Sonatron has this conception of radio tube service: to supply a tube for every socket in every set. Alert to each new trend in radio, and working with the resources of an organization of tube specialists, Sonatron engineers have made the Sonatron label a symbol of completeness, of quality and of long, superlative service. The World's Largest Radio Tube Line commands a world-wide appreciation which is expressed in steadily mounting sales . . . For a new kind of radio tube satisfaction and for the latest information on tubes—see your Sonatron dealer—there is one near you.

SONATRON TUBE COMPANY

16 Hudson St., New York City

1020 So. Central Park Ave., Chicago

55-57 State St., Newark, N. J.

Cable Address: SONATRON-NEWARK

If you are buying a new radio, demand Sonatrons as initial equipment. If you already own a set, replace with Sonatrons—and note the difference!

SONATRON TUBE COMPANY, 108 W. Lake St., Chicago
Gentlemen: Please send me the FREE book "How to Take Care of Your Radio Tubes."

Name

Street Address or R. F. D.

City and State

FREE!
to Set Owners
New 1929 Edition
of SONATRON'S famous book: "How to Take Care of Your Radio Tubes."

