

TELEVISION

RADIO'S GREATEST MAGAZINE

RADIOVISION

# RADIO NEWS

REG. U.S. PAT. OFF.

AUGUST  
25 Cents

Over 200  
Illustrations



Edited by HUGO GERNSBACK

## RADIO MOVIES and TELEVISION FOR THE HOME

(See Page 116)



TELEVISION

EXPERIMENTER PUBLISHING COMPANY, 230 FIFTH AVENUE, NEW YORK

RADIOVISION

# Cunningham RADIO TUBES

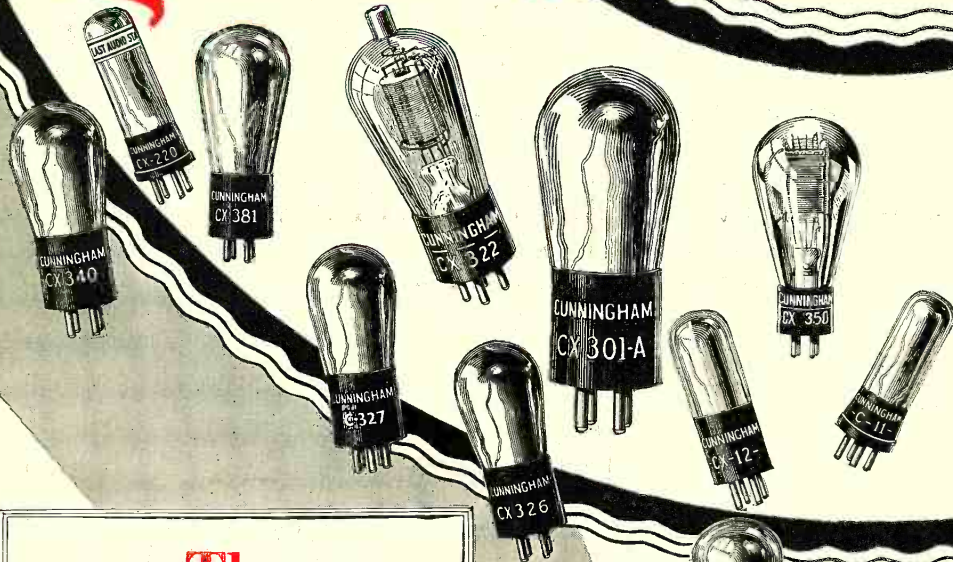

## The Nerve Center of Your Radio

Because Cunningham Radio Tubes carry the true tone and reproduce pure harmony, they are rightly called the nerve center of your radio.

Tubes that have had long, constant use should be replaced with new, correct Cunningham Tubes to enable you to enjoy modern broadcast reception.

*Never use old tubes with new ones—use new tubes throughout*

**E. T. CUNNINGHAM, Inc.**  
New York Chicago San Francisco

*Manufactured and sold under rights, patents and inventions owned and or controlled by Radio Corporation of America*

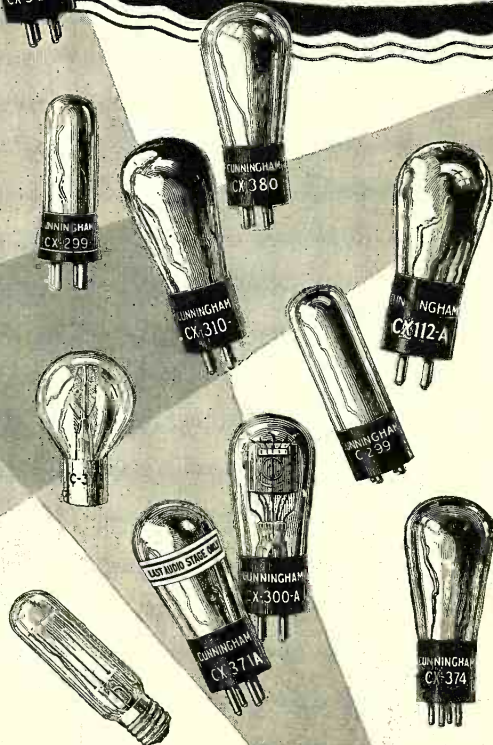

# EARNED \$500 SPARE TIME WITH RADIO

Coplay, Pa., June 4—(RA)—During the few months that Frank J. Deutsch has been a member of the Radio Association of America, he has made over \$500 out of Radio in his spare time.

"Four super-hetrodyne sets of my own construction brought me a profit of \$60.00 each, and the other profit was from sales of supplies purchased through the Wholesale Department of the Association," he said. "The Association certainly has a great plan for ambitious men."

In a neighboring state, Werner Eichler, Rochester, N. Y., another member of the Association, has been making \$50 a week during his spare time.

They are only two of the hundreds of Radio Association members who are making money out of Radio in their spare time.

## BECOMES RADIO ENGINEER IN ONE YEAR

Toronto, Canada, May 20—(RA)—One of the newly admitted associate members of the Institute of Radio Engineers is Claude DeGrave, a member of the engineering staff of the DeForest Company of this city. "I knew nothing about Radio and started from the ground up," Mr. DeGrave stated, "when I enrolled a year ago in the Radio Association. Its easy lessons and superb training made it possible for me to become a Radio Expert in less than a year's time. My income is now about 225% more than at the time I joined the Association."

The Institute of Radio Engineers is a very exclusive organization, and its membership requirements are very rigid, so that Mr. DeGrave has reason to be proud of his election.

## Clerk Doubles Income In Six Months Through Radio

Chicago, Ill., May 9—Even though his membership in the Radio Association has resulted in W. E. Thon securing the management of a Radio Department in a large Chicago store, his ambition was not satisfied. Six months later, he started his own store.

"The Radio Association has an excellent plan for the man who wants to get out of the rut and succeed," says this man who quickly rose from clerkdom to the proprietorship of a profitable radio store. "I attribute my success entirely to the Radio Association of America. Six months after I had enrolled, I had doubled my income through its help."

# 5 Easy Ways to make \$3.00 an hour in Your Spare Time in RADIO

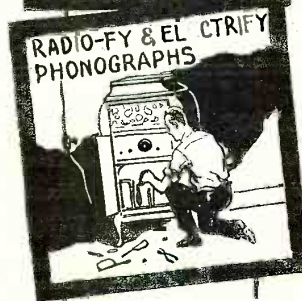
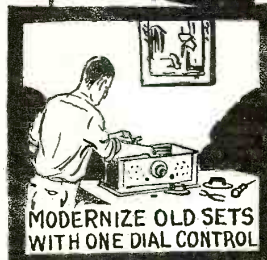

EACH of these plans, developed by the Radio Association of America, is a big money-maker. Set owners everywhere want to get rid of static, to have their sets operate from the electric light socket, the tone improved, and the volume increased, and transformed into single-dial controls. Phonograph owners want their machines electrified and radiofied. If you learn to render these services, you can easily make \$3.00 an hour for your spare time, to say nothing of the money you can make installing, servicing, repairing, and building radio sets, and selling supplies.

Over \$600,000,000 is being spent yearly for sets, supplies, service. You can get your share of this business and, at the same time, fit yourself for the big-pay opportunities in Radio by joining the Association.

## Join the Radio Association of America

A membership in the Association offers you the easiest way into Radio. It will enable you to earn \$3.00 an hour upwards in your spare time—train you to install, repair, and build all kinds of sets—start you in business without capital or finance an invention—train you for the \$3,000 to \$10,000 big-pay radio positions—help secure a better position at bigger pay for you. A membership need not cost you a cent!

The Association will give you a comprehensive, practical, and theoretical training and the benefit of our Employment Service. You earn while you learn. Our cooperative plan will make it possible for you to establish a radio store. You have the privilege of buying radio supplies at wholesale from the very first.

## ACT NOW—If you wish No-Cost Membership Plan

To a limited number of ambitious men, we will give Special Memberships that may not—need not—cost you a cent. To secure one, write today. We will send you details and also our book, "Your Opportunity in the Radio Industry." It will open your eyes to the money-making possibilities of Radio.

### COUPON

RADIO ASSOCIATION OF AMERICA  
Dept. RN-8, 4513 Ravenswood Ave.,  
Chicago, Ill.

Gentlemen:  
Please send me by return mail full details of your Special Membership Plan, and also copy of your book, "Your Opportunity in the Radio Industry."

Name.....  
Address.....  
City..... State.....

# RADIO NEWS

Volume 10

AUGUST, 1928

Number 2

## Contents of This Issue

What to Expect of Television By Hugo Gernsback	103	Some Inside Facts About "B" Batteries By William F. Crosby	134
A Visit to Radio Central By Robert Hertzberg	104	The Radio Beginner—A Two-Tube Reflex Receiver of Simple Construction	136
Getting the Vote by Radio By Marshall D. Beuick	108	A Booster Unit for the Browning-Drake By C. A. Oldroyd	139
Radio Advertising—Does It Pay? By Orrin E. Dunlap, Jr.	110	A Screen-Grid Short-Wave Receiver By Fred H. Canfield	142
Rain, Rays and Radio By C. Sterling Gleason	112	Better Direct-Coupled A.F. Amplifiers	146
The Listener Speaks By Himself	114	The Capacity of a Condenser Combination Arrangement By Leslie R. Jones	149
Broadcastatics	115	Radio Wrinkles	150
Television—Radio Movies and Television for the Home	116	The Zero-Reactance Plate Circuit By Sylvan Harris	152
Why the Weather Affects Radio Reception By B. Francis Dashiell	119	Learning the Code Multiplies Radio Pleasures By C. Walter Palmer	154
What's New in Radio	122	Letters from Home Radio Constructors	156
Some Odd Uses for Vacuum Tubes By J. E. Smith	126	Radiotics	158
Radio Novelties from Abroad and Home	128	RADIO NEWS LABORATORIES	159
List of Broadcast Station Calls	129	I Want to Know By C. W. Palmer	160
What Is a Good Loud Speaker? By Fred H. Canfield	130	On the Short Waves	162
		Circuit Changes on the Neutrotetodyne	181

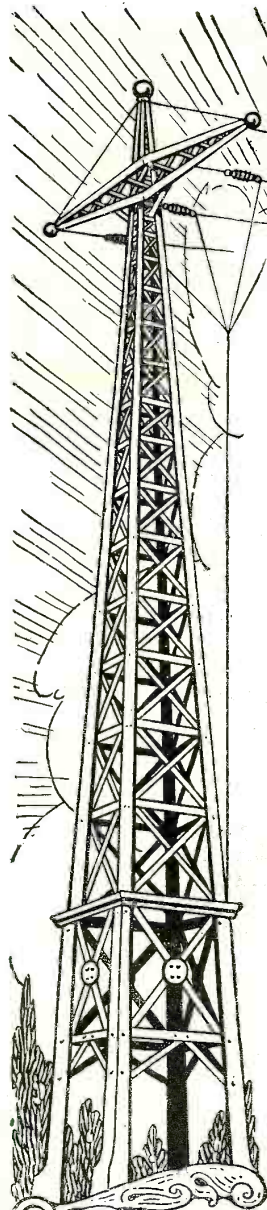

RADIO NEWS is published on the 10th of each preceding month. There are 12 numbers per year. Subscription price is \$2.50 a year in U. S. and possessions, Canada and foreign countries, \$3.00 per year. U. S. Coin as well as U. S. Stamps accepted (no foreign coins or stamps). Single copies, 25 cents each. Checks and money orders should be drawn to order of EXPERIMENTER PUBLISHING CO., INC.

All communications and contributions to this journal should be addressed to Editor, RADIO NEWS, 230 Fifth Ave., New York, N. Y. Unaccepted contributions cannot be returned unless full postage has been included. All accepted contributions are paid for on publication. A special rate is paid for novel experiments; good photographs accompanying them are highly desirable. Publishers are not responsible for loss of manuscripts, although every precaution is taken with such manuscripts, upon receipt thereof.

RADIO NEWS, Monthly. Entered as second-class matter, July 12, 1924, at the Post Office at New York, N. Y., under the Act of March 3, 1879. Additional entry at Dunellen, N. J. and San Francisco, Calif. Title registered U. S. Patent Office. Copyright, 1928, by The Experimenter Publishing Co., Inc., 230 Fifth Ave., New York. The contents of this magazine are copyrighted and must not be reproduced in the United States without giving full credit to the publication. Translation into foreign languages must not be made unless permission is

The contents of RADIO NEWS are indexed in the Industrial Arts Index, copies of which can be found in every library.

obtained from the publishers. Copyrighted in Germany. Reproduction of articles in Germany is reserved for Radio, Berlin 42.

RADIO NEWS is for sale at all newsstands in the United States and Canada, and at Brenano's, Ave. de L'Opera, Paris, France. European agents: S. J. Wise Et Cie, 40 Place Verre, Antwerp, Belgium.

HOW TO SUBSCRIBE FOR RADIO NEWS. Send your name, address and remittance to Experimenter Publishing Co., 230 Fifth Ave., New York. Mention the name of the magazine you are ordering. We also publish SCIENCE AND INVENTION, RADIO LISTENERS' GUIDE, AMAZING STORIES and TIDBITS. Write clearly.

RATES AND TERMS. The subscription rate for RADIO NEWS is \$2.50 per year. (12 numbers). When remitting do so by check, money order, or registered letter if cash is enclosed. Avoid sending cash through the mail if possible. Subscriptions for less than one year are not accepted. Subscription may be made in combination with SCIENCE & INVENTION, RADIO LISTENERS' GUIDE, AMAZING STORIES and TIDBITS.

POSTAGE. We prepay postage in all parts of the United States, Mexico and island possessions. For foreign or Canadian subscriptions we require 50 cents in addition to the subscription price for additional postage charge.

CHANGE OF ADDRESS. Notify us as far in advance as possible. It requires several weeks to make an address change on our records. Always write clearly.

Published by **Experimenter Publishing Company, Inc.**

H. GERNSBACK, President      S. GERNSBACK, Vice-President and Treasurer      C. E. ROSENFELT, Secretary

Member: Audit Bureau of Circulations      Radio Magazine Publishers Association

Editorial and General Offices      230 Fifth Avenue, New York City

Advertising Representatives: RHODES & LEISENRING  
New York Offices: 624 Graybar Building      Chicago Offices: 307 North Michigan Ave.

# Announcing A GREAT, NEW RECEIVER SCOTT CHALLENGES THE WHOLE WORLD OF RADIO TO ANY KIND OF COMPETITIVE TEST



**E. H. SCOTT**  
Designer of the World's Record Super 10, the receiver which, prior to the advent of this new model, held all records for radio set performance

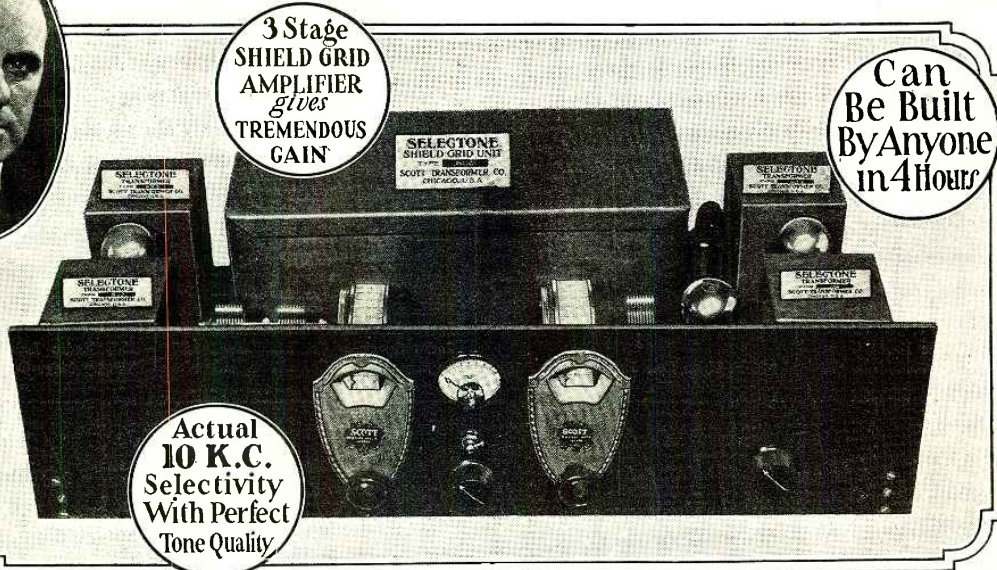

3 Stage  
SHIELD GRID  
AMPLIFIER  
*gives*  
TREMENDOUS  
GAIN

Can  
Be Built  
By Anyone  
in 4 Hours

Actual  
10 K.C.  
Selectivity  
With Perfect  
Tone Quality

## More Actual Amplification • More Distance and Volume than Any Other Existing Receiver Known to Us

This—we believe, is the most powerful, the most selective and the finest toned receiver in existence today. We draw this conclusion from having tested and scientifically measured every other receiver which might claim itself the equal of the SCOTT World's Record Shielded Grid NINE. And there is no question but that this radically new type of receiver will maintain its position of obvious superiority for years to come, for the features of circuit engineering responsible for its amazingly better performance are far ahead of any circuit developed to date.

**UNLIMITED RANGE.** So tremendous is the amplification of the *Shielded Grid* long range amplifier employed, that it is impossible to determine a range limit for this receiver when used with a short antenna and a ground connection.

### Shielded Grid Tubes Used In Perfected Circuit

Standard circuits commonly in use with the new shielded-grid tubes, provide actual amplification of approximately 40 per stage. The revolutionary new circuit used exclusively in the SCOTT Shielded Grid NINE, gives a practical amplification of 140 per stage, thereby making this receiver

many times more powerful than receivers using shielded-grid tubes in a conventional manner. It is this new circuit arrangement developed and used exclusively by us which enables us to challenge the whole world of radio to any kind of competitive test with assurance that the SCOTT Shielded Grid NINE will win.

### Economical To Operate

The *Shielded Grid 9* draws only 29 mils. and can be operated with dry batteries. For use with A. C. current we have designed a new Power Pack which has incorporated in it a power audio stage, using a 250 power tube. This gives immense volume with perfect tone quality.

### Easy to Build --- Results Guaranteed

Despite the fact that the Scott Shielded Grid NINE is one of the most elaborate receiving systems ever devised—and despite the fact that it embodies many features of circuit arrangement not known to common practice, it is a very easy set to build, and when you buy the kit of parts we positively guarantee that you will get the same results we get from our laboratory model. Both panel and sub-panel are drilled to receive each part and the shield-grid amplifier units come to you fully wired and tested—ready to be connected into the circuit just as though they were a transformer.

### Why Pay More for Less?

Why pay more than the small cost of the Scott Shielded Grid NINE when no other receiver offers you so much? Why not have a receiver which provides actual 10 Kilocycle selectivity regardless of where located? Why not have a receiver with which you can listen in on all the world—no limit to its distance range. The Scott Shielded Grid NINE is, unquestionably the finest, most powerful, most advanced receiver of the day, and is, beyond all doubt, destined to hold its position of leadership, throughout the coming years. It is the ultimate. Build it—enjoy it NOW.

# FREE

## Circuit Diagram and Particulars

Find out all particulars of the Scott Shielded Grid NINE. Examine its circuit. See for yourself why it has unlimited range—unlimited power—perfect tone. Proof of the superiority of this great new receiver is FREE to you. Also copies of 6000 and 9000 mile reception verifications and other records made by the Scott World's Record Super 9 and the Super 10, the less powerful predecessors of the new Scott Shielded Grid NINE. Get this information now. Simply clip and mail the coupon. Mail it TODAY!

**SCOTT TRANSFORMER CO.**  
4446-4448 Ravenswood Ave., Dept. K  
CHICAGO, ILL.

Mail this  
Coupon

SCOTT  
TRANSFORMER CO.  
4446-4448 Ravenswood Ave.  
Dept. K, Chicago, Ill.

Send me full particulars of the new Scott Shielded Grid NINE.

**SCOTT**  
WORLDS RECORD  
SHIELD GRID  
**9**  
SUPER

Name.....  
Street.....  
Town..... State.....

# INDEX TO ADVERTISERS

	Page		Page		Page
<b>A</b>		<b>D</b>		<b>K</b>	
Abox Company, The.....	Back Cover	Daven Radio Corp., The.....	172	Kimley Electric Co. ....	182
Accusti-Cone .....	171	Deutschmann Co., To-be.....	178		
Acme Wire Co., The.....	179			<b>L</b>	
Aero Products, Inc. ....	183	<b>E</b>		Lacault, R. E. ....	188
Aerovox Wireless Corp.....	181	Electrad, Inc. ....	171	Lacey & Lacey .....	189
All Radio Co. ....	183	Electric Specialty Co. ....	183	Leutz, Inc., C. R.....	165
American Mechanical Labs., Inc.	171	Electro Chemical Co. of America	183		
American Sales Co. ....	173	Excello Products Corp. ....	181		
American Transformer Co. ....	166			<b>M</b>	
Amrad Corporation, The.....	181	<b>F</b>		M. & H. Sporting Goods Co.....	172
		Fanspeaker Radio Co. ....	175	Midwest Radio Corp'n.....	191
<b>B</b>		Fansteel Products Co., Inc.....	175	Muter Co., Leslie F. ....	175
Barawik Company, The.....	177-183-186	Formica Insulation Co. ....	183		
		Freshman Co., Inc., Chas. ....	186		
				<b>N</b>	
<b>C</b>		<b>G</b>		National Radio Institute.....	101
C. E. Mfg. Company, Inc. ....	181	General Antenna Co. ....	187	Norden-Hauck, Inc. ....	180
Carborundum Co., The.....	186	General Radio Co. ....	182		
Carls, M. J. ....	177	Gernsback, S. ....	172	<b>P</b>	
Carter Radio Co. ....	172			Pilot Electric Mfg. Co., Inc.....	100
Central Radio Labs. ....	176	<b>H</b>		Press Guild, Inc. ....	185
Chemical Institute of New York,		Hammarlund Mfg. Co. ....	173		
Inc. ....	169	Hamilton-Carr Radio Corp. ....	176		
Chicago Radio Apparatus Co.....	184			<b>R</b>	
Cloverleaf Mfg. Co. ....	178	<b>I</b>		Radiall Company .....	191
Consrad Co., Inc. 164-168-170-180-185		Independent Electric Works.....	184	Radio Association of America....	97
Consumers Radio Co. ....	172	Illinois Transformer Co. ....	183	Radio Equipment Co. ....	182
Craftsman Radio Products.....	183			Radio Institute of America.....	189
Cunningham, Inc., E. T. ....		<b>J</b>		Radio Specialty Co. ....	167
Inside Front Cover		J-M-P Mfg. Co., Inc.....	180	Raytheon Mfg. Co. ....	178
Curtan Mfg. Co. ....	102				
				<b>S</b>	
				Scott Transformer Co. ....	99
				See Jay Battery Co. ....	181
				Smith, B. Hawley.....	180
				Spiegel Radio Co. ....	182
				Starrett Mfg. Co. ....	186
				<b>T</b>	
				Telephone Maintenance Co. ....	171
				Teleplex Co. ....	181
				Televoal Corp. ....	191
				Thordarson Electric Mfg. Co.....	163
				Townsend Laboratories.....	175
				Transformer Corporation of	
				America .....	176
				Tyrman Electric Corp. ....	171
				<b>U-V</b>	
				Underground Aerial Systems.....	177
				Underground Antenna Company	
				Inside Back Cover	
				<b>W</b>	
				Walker Co., The Geo. W.....	177
				Western Radio Mfg. Co. ....	175
				Wirt Co. ....	188
				World Battery Co. ....	166
				<b>X-Y-Z</b>	
				X-L Radio Laboratories.....	176
				Yaxley Mfg. Co. ....	188

# PILOT ENGINEERING creates new precision standards for radio parts



This Pilot "Moisture-Proof" Transformer was removed from the receiver and immersed for one entire week as shown. When re-installed in the set, it functioned perfectly.

**EVERY** Pilot instrument must be approved by our Board of Engineers. Beauty of appearance is never allowed to supersede beauty of performance. You are sure of the electrical efficiency of every instrument that bears the Pilot name, whether it be a simple little socket, a variable condenser, plug-in coils, filter, choke, transformer, or complete kit.

SEND 4c. STAMP FOR CATALOG

**"PILOT'S 'FLYING LAB'"**

The Pilot Airplane Radio Laboratory is the Pilot Company's contribution to the development of a radio communication system between amateur ground and air stations, enabling pilots to receive directions and weather warning while aloft.

**"PILOT RADIO PARTS ARE SOLD IN EVERY**

**RADIO'S BIGGEST  
25¢ VALUE!**

**CIVILIZED COUNTRY  
IN THE WORLD!**

"RADIO DESIGN," a Quarterly Magazine edited by M. B. Sleeper, national radio authority, is brimming over with the newest and latest Short Wave, A. C. Data, Power Amplification, latest Television Development, etc. Send 25c. stamps or coin for four meaty quarterly issues.

Name.....  
Address.....

## PILOT ELECTRIC M'FG. CO

323 BERRY ST. BROOKLYN, N.Y. INC.

TRADE MARK REGISTERED

**"WORLD'S LARGEST RADIO PARTS PLANT"**

**Read what BIG money these fellows have made in the RADIO BUSINESS**

**\$375 One Month Spare Time**



"Recently I made \$375 in one month in my spare time installing, servicing, selling Radio sets. And, not so long ago, I earned enough in one week to pay for my course."  
**EARLE CUMMINGS,**  
 18 Webster St., Haverhill, Mass.

**\$1597 In Five Months**



"The N. R. I. is the best Radio school in the U. S. A. I have made \$1597 in five months. I shall always tell my friends that I owe my success to you."  
**HENRY J. NICKS, Jr.,**  
 302 Safford Ave.,  
 Tarpon Springs, Fla.

**\$1164 Spare Time Profits**



"Look at what I have made since I enrolled, \$1,164—money I would not have had otherwise. I am certainly glad I took up Radio with N. R. I. I am more than satisfied."  
**HENRY R. HEIKKINEN,**  
 123 W. Erie St., Chicago, Ill.

**Over \$1000 In Four Months**



"My opinion of the N. R. I. course is that it is the best to be had at any price. When I enrolled I didn't know a condenser from a transformer, but from December to April I made well over \$1000 and I only worked in the mornings."  
**AL. JOHNSON,**  
 1499 Shelby St., Sandusky, Ohio.

# I will show you too how to start a spare time or full time Radio Business of Your Own without capital



Radio's amazing growth is making many big jobs. The world-wide use of receiving sets and the lack of trained men to sell, install and service them has opened many splendid chances for spare time and full time businesses.

Ever so often a new business is started in this country. We have seen how the growth of the automobile industry, electricity and others made men rich. Now Radio is doing the same thing. Its growth has already made many men rich and will make more wealthy in the future. Surely you are not going to pass up this wonderful chance for success.

**More Trained Radio Men Needed**

A famous Radio expert says there are four good jobs for every man trained to hold them. Radio has grown so fast that it simply has not got the number of trained men it needs. Every year there are hundreds of fine jobs among its many branches such as broadcasting stations, Radio factories, jobbers, dealers, on board ship, commercial land stations, and many others. Many of the six to ten million receiving sets now in use are only 25% to 40% efficient. This has made your big chance for a spare time or full time business of your own selling, installing, repairing sets.

**So Many Opportunities You Can Make Extra Money While Learning**

Many of our students make \$10, \$20, \$30 a week extra while learning. I'll show you the plans and ideas that have proved successful for them—show you

how to begin making extra money shortly after you enroll. G. W. Page, 1807-21st Ave., S., Nashville, Tenn., made \$935 in his spare time while taking my course.

**I Give You Practical Radio Experience With My Course**

My course is not just theory. My method gives you practical Radio experience—you learn the "how" and "why" of practically every type of Radio set made. This gives you confidence to tackle any Radio problems and shows up in your pay envelope too.

You can build 100 circuits with the Six Big Outfits of Radio parts I give you. The pictures here show only three of them. My book explains my method of giving practical training at home. Get your copy!

**I Will Train You At Home In Your Spare Time**

I bring my training to you. Hold your job. Give me only part of your spare time. You don't have to be a college or high school graduate. Many of my graduates now making big money in Radio didn't even finish the grades. Boys 14, 15 years old and men up to 60 have finished my course successfully.

**You Must Be Satisfied**

I will give you a written agreement the day you enroll to refund your money if you are not satisfied with the lessons and instruction service when you complete the course. You are the only judge. The resources of the N. R. I. Pioneer and Largest Home-Study Radio school in the world stand back of this agreement.

**Get My Book**

Find out what Radio offers you. My 64-page book, "Rich Rewards in Radio" points out the money making opportunities the growth of Radio has made for you. Clip the coupon. Send it to me. You won't be obligated in the least.

**Address**

**J. E. Smith, Pres.**

**Dept. 88**

**National Radio Institute  
Washington, D. C.**

*This Book points out what Radio offers You Get a copy!*

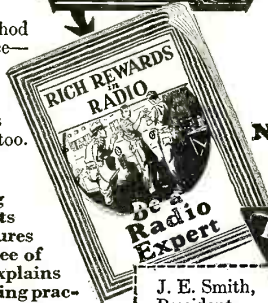

**This coupon is good for a FREE copy of my Valuable Book. Mail it NOW!**

J. E. Smith,  
 President,  
 Dept., 88  
 National Radio Institute, Washington, D. C.

Dear Mr. Smith: Send me your book. I want to know more about the opportunities in Radio and your practical method of teaching at home in spare time. This request does not obligate me to enroll and I understand no agent will call on me.

Name.....Age.....  
 Address.....  
 City.....State.....

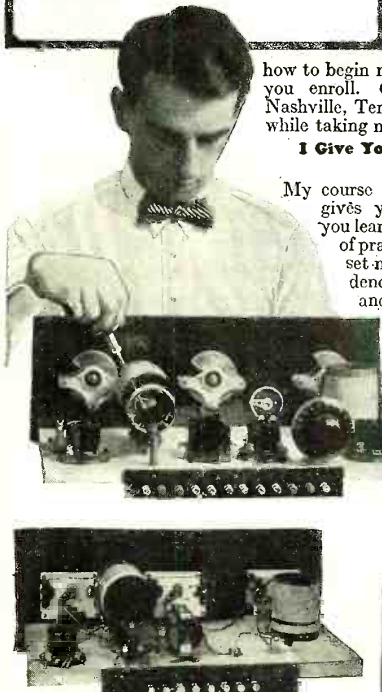

# Amazing Ground Antenna

## Gets Winter Reception in Summer

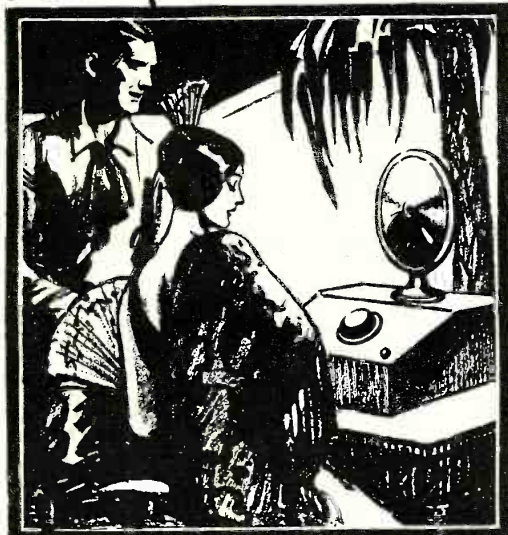

### "Improves Music Wonderfully"

It is no longer necessary to say "Good-Bye Radio" for the summer. Science says that clear, pure ground waves remain just the same during the summer months. They are unaffected by Atmospheric conditions. Aer-O-Liminator is the proved, scientific successful means of bringing these ground waves to your set loud and clear, while others are giving up summer reception in despair because of maddening, music-destroying static.

#### Proof Comes from the Semi-Tropics

The letter from Mexico reproduced above speaks volumes. The Spanish are great music-lovers and are trained to judge. When AER-O-LIMINATOR improves music wonderfully in Mexico—a semi-tropical climate—you know it literally gets "Winter reception in summer." Distant stations formerly drowned out by the static interference of noisy air-waves now come in clear and with the melodious tone of a bell. Winter or Summer, there is no comparison in reception with Aer-O-Liminator and without it.

#### Engineer Recommends Aer-O-Liminator to Every Radio Owner

Reception on any type receiver is improved with the use of Aer-O-Liminator. This has been proved countless times on both D.C. and A.C. Sets. John E. Christensen, Chicago Radio Engineer, says, "I have tested and thoroughly approve the 'Aer-O-Liminator.' I find it increases selectivity and volume without distortion, eliminates static, gives good, clear tones, both on LOCAL and DISTANT stations. I would recommend the use of Aer-O-Liminator to every radio owner to get the best reception from his Set."

#### Send Coupon for Free Trial

Install an Aer-O-Liminator (Ground Antenna). Leave your old overhead aerial up. Try out on a night when static is bad. If you do not get a wonderful improvement in freedom from static, greater selectivity and clear, sweet tone without interfering noises, if you can't get good reception on stations that are drowned out by static on your roof aerial, you need not pay us a red cent for this test! Send coupon at once for scientific explanation of Aer-O-Liminator (Ground Antenna), proof of performance, and our conclusive iron-bound guarantee and remarkable Free Trial Offer—Mail Coupon TODAY!

**CURTAN MFG. COMPANY**  
Dept. 827-L.A. 154 F. Erie St., Chicago, Ill.

# Aer-O-Liminator

(Ground Antenna)

**USE THIS CONVENIENT COUPON TODAY**

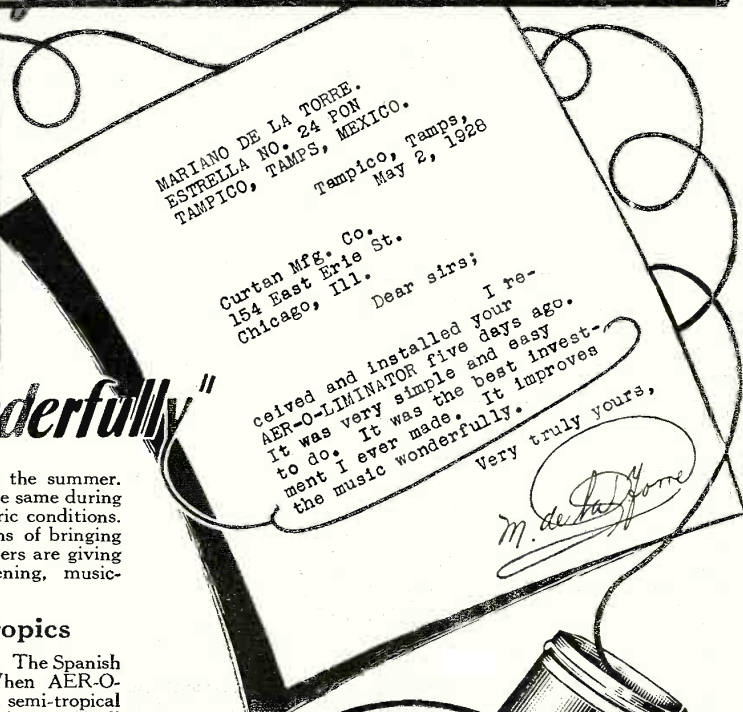

MARTIANO DE LA TORRE.  
ESTRELLA NO. 24 PON  
TAMPICO, TAMPS, MEXICO.  
Tampico, Tamps,  
May 2, 1928

Curtan Mfg. Co.  
154 East Erie St.  
Chicago, Ill.

Dear sirs;

I received and installed your AER-O-LIMINATOR five days ago. It was very simple and easy to do. It was the best investment I ever made. It improves the music wonderfully.

Very truly yours,



MAKE THIS  
FREE TRIAL

Aer-O-Liminator

Dept. 827-L.A.

NAME \_\_\_\_\_

Address \_\_\_\_\_

City \_\_\_\_\_ State \_\_\_\_\_

Please send me at once complete description of Aer-O-Liminator, with details of Guarantee, Scientific Proof, and Free Trial Offer.

CURTAN MFG. COMPANY,  
154 E. Erie St., Chicago, Ill.





Editorial and General Offices, 230 Fifth Avenue, New York

Vol. 10

AUGUST, 1928

No. 2

## What to Expect of Television

By HUGO GERNSBACK

**N**OW that television has actually arrived, it may be well to take stock of the new art, and to look into the future. The word "Television" was first coined by myself in an article entitled "Television and the Telephot," which appeared in the December, 1909, issue of MODERN ELECTRICS, the pioneer radio publication, which I published. I believe that these were the first articles on the art of television published in the United States.

Before going much further, I must sound a precautionary note, and that is: *do not expect too much of television for some time to come.* At the present time, there is feverish activity by many firms, large and small, to put television receivers on the market.

Station WGY of Schenectady may be called the pioneer television broadcaster, as it started to broadcast television some time in May of this year. Station WRNY began broadcasting television in June.

"What will we be able to see?" is the question that is most frequently asked. Frankly, not a great deal. We shall be satisfied if it is possible to clearly see silhouettes, letters, designs, diagrams, large print and so forth; that is, with television broadcast over the usual broadcast channels. Here, for the present, we must be satisfied with rather coarse and indistinct details at the receiving side; although a number of broadcasters will probably broadcast television on short waves, where the details will have greater clearness, due to the wider frequency channels available.

Like all arts, television must first pass through a preliminary stage, and from the experience we gain during the first few months, better and better transmission may be expected.

We all remember the time when "wireless" first arrived, and when, prior to 1920, all we could get in our head receivers was dots and dashes—and these not always clear—rather than actual voices and music, now known as broadcasting. It will be so with television; so don't expect too much, and you won't be disappointed. In my opinion, it will be quite marvelous if, on your television receiver, you will be able to see good silhouettes, and can read large letters, broadcast from the studio.

And don't expect simultaneous transmission of voice and television. That, at the present stage of the art, is not possible. The procedure will run somewhat like this:

The studio announcer will say, "Now we shall televise such and such an object." It will take one or two minutes to show the object, and then the voice or sounds from the studio will again be heard in your receiver. In between announcements, you will be able to pick up television on your television receiver; but you can't get both together until an entirely new invention is made, which, to my knowledge, is not as yet in sight. It may, however, come along any time.

At the receiving end, we have a revolving disc, which is usually made of aluminum, about 14 to 24 inches in diameter, and through it a number of holes. Directly behind the holes is a neon lamp, which is attached to your ordinary radio receiver. If necessary, the impulses coming through your radio broadcast receiver may be amplified in order to make the light of the neon lamp bright enough for receiving purposes.

The aluminum disc is rotated by means of a motor, and your television receiver will have a rheostat in series with the field of the machine. By adjusting this rheostat, you will be able to keep the rotation of your disc in step with that of the transmitter at the distant station. Through the holes, a "virtual" picture is built up, and thus you see what is shown at the broadcast studio.

This, at best, is a more or less crude way of doing things, and will not prevail in the future. It may be stated that the use of the present revolving discs at both the transmitter and receiver corresponds to the coherer-and-spark-gap stage of the old days of "wireless."

The ideal television receiver of the future will have no moving parts at all. There will be no motor, or if there is one, there certainly won't be a large disc such as we have now. What we probably will have is some sort of a cathode tube, in which a weightless electron beam will rotate in an induced magnetic field. It will be much easier to keep such a device as this in synchronism, and there is no doubt that the built-up picture thus produced at the receiving end will be far superior to what we have today.

The question that is asked frequently about present-day devices is, "How big is the received picture that you see?" As a rule, it is not large. This depends upon the diameter of the disc and the size of the plates of the neon tube. Usually, the picture is about two to three inches high, and from one and one-half to two inches wide. It is possible to enlarge this picture by means of a lens, and thus get a larger image; but so far experiments along these lines have not been very fruitful, because the picture becomes coarse and loses its luminosity as well.

As for televising the artists in the studio (that is, showing the radio audience what the artists look like), it seems quite a few months in the future; or, if they are shown at the present time, it will be most difficult to distinguish a man from a woman. These remarks are meant to apply only when the impulses are broadcast over the present broadcast band of wavelengths, that is, between 200 and 550 meters, and kept within the 5,000-cycle limit under which broadcasters operate. On the short-wave channels, as I said before, details are usually much clearer.

From the above, it should be understood that such a thing as televising in detail a moving object in the studio (for instance, a pianist playing) will not be possible for quite awhile to come. Anything in motion will be extremely difficult to receive and see well, with any kind of detail.

But the important point is that a start has been made, and that the public is interested. That is what counts. If enough people work on the new art, progress will no doubt be made quickly. I predict that, within one year, such tremendous strides will have been made in television that it will be possible actually to see what is going on in a distant studio.

But the broadcasting of such events as a ball game or a boxing match would seem, at the present time, to be distant anywhere from two to five years; at least, until such time as an entirely new television device will have been invented. That is, as I said before, not as yet in sight.



# A VISIT TO "RADIO CENTRAL"

## What the Radio Fan May See at Rocky Point, Long Island, the Hub of a World-Wide Communication System

by Robert Hertzberg

The scene above includes the main transmitter house at "Radio City", and the lead-ins from the two great aerials; the nearest towers of one aerial are seen at the left. They are 410 feet high.

**T**HE largest and probably the most interesting radio installation in the world is the one known as "Radio Central," located at Rocky Point, Long Island, at a distance of about 75 miles from New York City. It bears this name because of its massed facilities for radio-telegraph and radio-telephone communication between the United States and the countries of Europe and South America, on wavelengths ranging from 14 meters all the way up to 16,000 meters. It is owned and operated by the Radio Corporation of America, and is the hub of that company's world-wide radio system.

Radio Central was opened six years ago. At that time two powerful Alexanderson alternators, huge machines capable of generating the high-frequency current necessary for the production of radio waves, were installed in a temporary building. These worked with two aerials supported by twelve huge steel masts, each 410 feet high. The original plan was to build 72 such towers, arranged like the spokes of a wheel, with six towers to a spoke, and with an individual Alexanderson alternator for each unit.

However, the progress of American radio technique, particularly in the line of short-wave work, made a change in the plan advisable. In place of the projected additional towers and giant alternators, the Radio Corporation has erected short, simple aerials supported by wooden poles; and has installed silent vacuum-tube transmitters of compact construction.

### AN IMPRESSIVE VIEW

In selecting a location favorable for the

projection of radio waves, the R.C.A. engineers chose a stretch of land at Rocky Point because the terrain here is very flat and free of metallic obstructions that might affect radio transmission. Some six thousand acres of land are included in the property—sufficient to take care of the growing radio plant for several years.

On a clear day a motorist approaching Radio Central can see the outlines of the twelve main towers many miles away. The sight of the huge steel skeletons lined up in a row three miles long is a most thrilling one, the height and size of the structures being emphasized by the bareness of the surrounding countryside. Adding to the general effect is a series of four smaller towers, each about 200 feet high, recently erected for directive transmission on short wavelengths. When viewed from certain angles

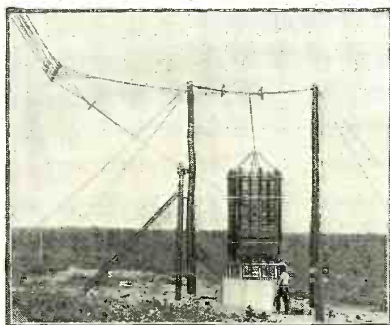

One of the coils which tune the sections of the "multiple-tuned" aerials. Compare it with the height of the man beside it.

the whole system of towers, poles and suspended wires, honeycombing the sky in a dizzy manner, presents a picture not unlike those highly-imaginative drawings representing life on Mars that "Paul" used to paint for some of the old numbers of *The Electrical Experimenter*. On a slightly foggy day, when the tops of the aerials are clouded with mist, the towers appear to be miles high.

### THE MAIN POWER HOUSE

A short ride over a private road leading off one of the main Long Island highways brings the visitor to the main power house, or transmitting building. When this was first erected it was a plain brick affair, with unfinished sides of sheet metal. Today, however, it presents the Spanish Mission type of architecture, having cream-colored walls, attractive brick trim, and a red-tiled roof. It is located between the two sets of towers, which extend away from it a mile and a half in two directions. In front of the house is a large cement basin, in which jets of water are constantly spouting. These are not merely ornamental, but serve as a means of cooling the water which is fed to the alternators and vacuum tubes for cooling purposes.

Entering the main entrance of the power house, the visitor finds himself in a large reception hall of Spanish atmosphere; large tiles underfoot, rough stucco walls, massive mission doors with wrought-iron fittings, marble benches and iron railings leading to a balcony. A door connects this room with the machinery hall, the atmosphere of which is strictly business. The unceasing whirr of the huge Alexanderson generators and of

dozens of different kinds of pumps and incidental generators and the constant slapping of the big relay keys which tap out the messages makes conversation here a bit difficult. The staggering amount of radio equipment in this hall, which is about half a block square, leaves the visitor helplessly confused until after he has gone around two or three times and identified each machine.

#### THE INVISIBLE OPERATORS

Radio Central is a transmitting station or, rather, it is eight or nine stations rolled in one, yet the number of people staffing it is surprisingly small. On the occasion of the writer's visit only half a dozen or so men were in sight, and these were attendants and mechanics who had nothing to do with the flow of dots and dashes passing through the equipment. It was explained that the actual operators are located in a central office at 66 Broad Street, New York, to which messages from all parts of the country intended for transoceanic transmission are routed for handling. However, practically all the members of the Rocky Point staff are experienced radio operators and capable of handling messages in an emergency. Special wire lines between Broad Street and Rocky Point enable the operators in New York to control the "keying" of the various transmitters at will.

At least one of the two Alexanderson alternators is always operating into one of the big aerials. The various short-wave units are likewise kept in continuous service; if there is a lull in the message traffic an automatic "keyer" is started and sends a

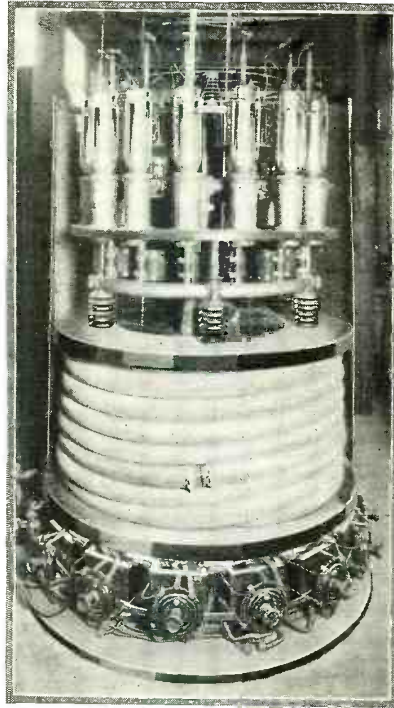

This circular bank of fifteen 20-kilowatt power-amplifier tubes is used in the transatlantic radio-telephone transmitter. It stands about seven feet high. The coils of hose carries the water required to cool the plates of the tubes.

series of test letters, usually ABC or XYZ, merely to let the receiving operators thousands of miles away know that the machinery is working properly. The other big aerial is used for transatlantic telephony on a wavelength of about 5,000 meters, being employed in conjunction with a 200-kilowatt transmitter. This latter outfit is operated by the American Telegraph and Telephone Company, and ties in with the entire American telephone system.

Although great progress has been made in long-distance communication on short waves with low power, the Alexanderson alternators, operating on wavelengths above 16,000 meters with an output of 200 kilowatts each, represent the backbone of transoceanic message service. The long waves are required for uninterrupted communication from daylight to darkness, for uniform and reliable transmission 24 hours a day regardless of weather. A single short-wave transmitter working on one fixed wavelength cannot supply the same class of service; engineers are now conceding the necessity for a group of different transmitters which can be shifted at will to meet the peculiar effects of daylight and darkness on the carrying powers of their respective wavelengths. Marked economies are effected many times with the use of short waves instead of the longer ones, for less power is required and the transmitting speeds can be greatly increased. At Radio Central short-wave transmitters are handling more and more traffic to Europe and Latin America and are being used experimentally for directive transmission to selected countries.

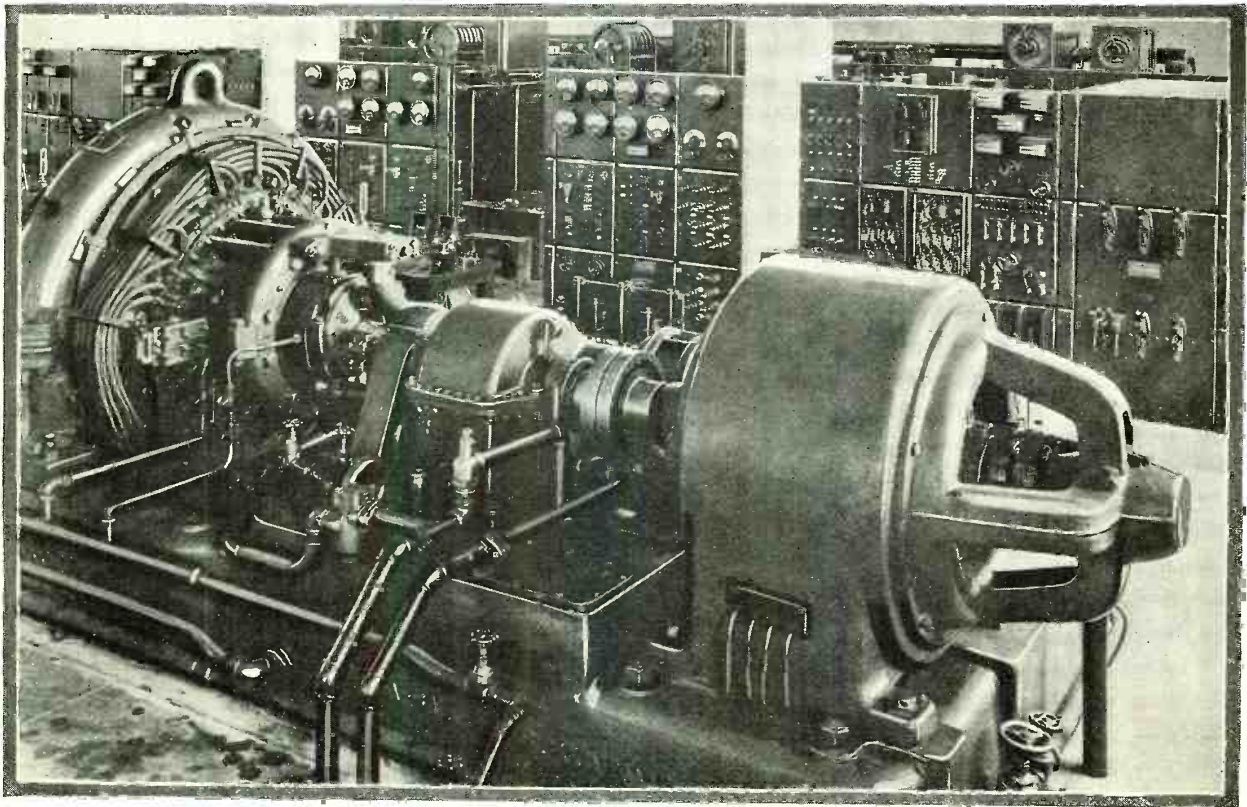

One of the two 200-kilowatt Alexanderson alternators used to supply current for the long-wave transmissions at "Radio Central." The alternator, proper, is the generator at the extreme left, while

its driving motor is in the right foreground. The various control switchboards supply the background. These big machines furnish current for stations WQK and WSS, from 1875 cycles down.

## ADVANTAGES OF THE BEAM SYSTEM

Although the aerials of the "beam" transmitters produce waves that eventually spread over a considerable distance, the directive system offers the advantage of doubling the usefulness of each wavelength. For instance, two separate short-wave beam transmitters directed toward England and South America, respectively, may operate on the same wavelength, because the receivers in England will not pick up the waves directed at South America, and the receivers in South America will be free of serious interference from the waves directed toward England. Secrecy of transmission is not the primary object of the beam system, as many radio fans seem to think. From even the best beam stations, enough energy leaks out through the backs of the reflectors and splashes off through the sides to make the signals readable in unexpected parts of the world.

Surrounding the two Alexanderson long-wave alternators at Rocky Point are six short-wave transmitters, which may be listed as follows:

WTT—40 kilowatts; 16.1 meters. Operating to South America, daytime only.

2XT—40 kilowatts; 16.18 meters. Operating to Europe, daytime only.

WBU—20 kilowatts; 14.1 meters. Operating to South America.

WIK—20 kilowatts; 21.75 meters. Operating to Central America, Porto Rico and Europe, 24 hours.

WQQ—20 kilowatts; 14.8 meters. Operating to South and Central Americas, from 5.00 a. m. to 11.00 p. m.

WLL—20 kilowatts; 16.01 meters. Operating to South America and Central America, from 5.00 a. m. to 11.00 p. m.

It will be noted that the transmitters operating below 17 meters are used for day-

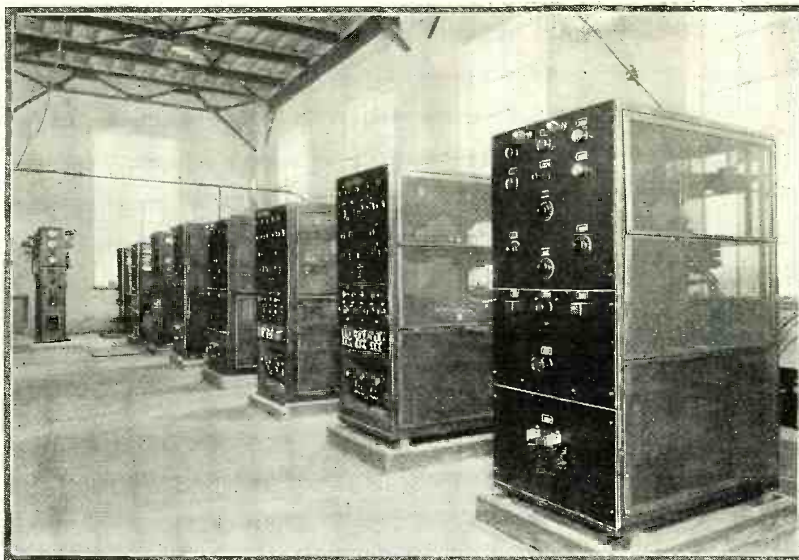

A series of short-wave transmitters at "Radio Central"; the third unit from the right is that of WTT, which operates on 16.1 meters, sending messages to South America. Compare the compactness of these vacuum-tube outfits with the size of the Alexanderson generator on page 105.

light work only, because of the peculiarities of these short waves. In some instances, a transmitter working with Europe in daylight becomes highly efficient for communication with South America at night, and vice versa.

While the high-power alternators work with lofty and widespread aerials, the short-wave transmitters use lower and less conspicuous antenna systems. The latter are supported by plain wooden poles, usually not over sixty feet high, the aerials them-

selves consisting for the most part of short vertical lengths of wire or copper rod. A few of the aerials are merely thirty-foot lengths of wire hanging from the guy cables of the big steel masts; yet with them reliable high-speed communication with Europe is maintained day after day.

## THE "MULTIPLE-TUNED" AERIALS

The lead-ins from the two aerials, supported by the 410-foot steel towers, drop to the ground a short distance from the transmitter house, and are connected to the generators and to the telephone transmitter by radio-frequency transmission lines. These big aerials are of the "multiple-tuned" type. Separate lead-ins drop from the overhead wires, where they pass under each of the twelve towers, and connect to huge exposed tuning coils. These tune each of the sections of wire between masts to the wavelength on which the transmitter is working. Thus it may be seen that each of the two big aerials really consists of six separate aerials forming a continuous stretch of wire.

The short-wave aerials are removed a considerable distance from the actual transmitters; as far away as a mile. The energy from the transmitters is carried to them over radio-frequency transmission lines, which are merely pairs of thin wires strung on poles about eight feet above the ground.

The beam aerials erected for directive transmission are rather unusual in appearance. At Rocky Point there are two types in use: the British and the American. The British system employs four 200-foot steel towers arranged in a straight line. A series of rigid messenger cables, suspended across their tops, supports a double row of vertical wires, running parallel to each other and separated about twenty feet. One set of these hanging wires acts as the aerial from which the radio waves are radiated; the other as a reflecting wall which throws back the waves and makes them travel only in the direction in which the first set face.

The American system is similar, but makes use of short, heavy wooden poles to support the rows of vertical wires which act as radiators and reflectors, respectively.

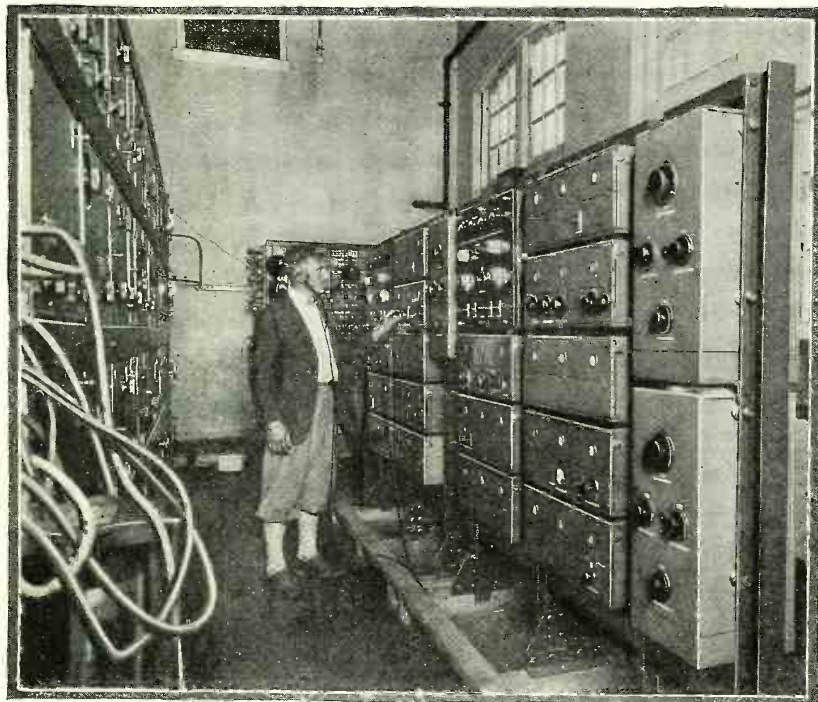

This is a section of the receiving house of "Radio Central," located at Riverhead, west of the transmitters. The operator is adjusting one of the short-wave receivers, which will be left tuned to the proper wavelength. Behind him, at the left, are four long-wave receivers in their rack.

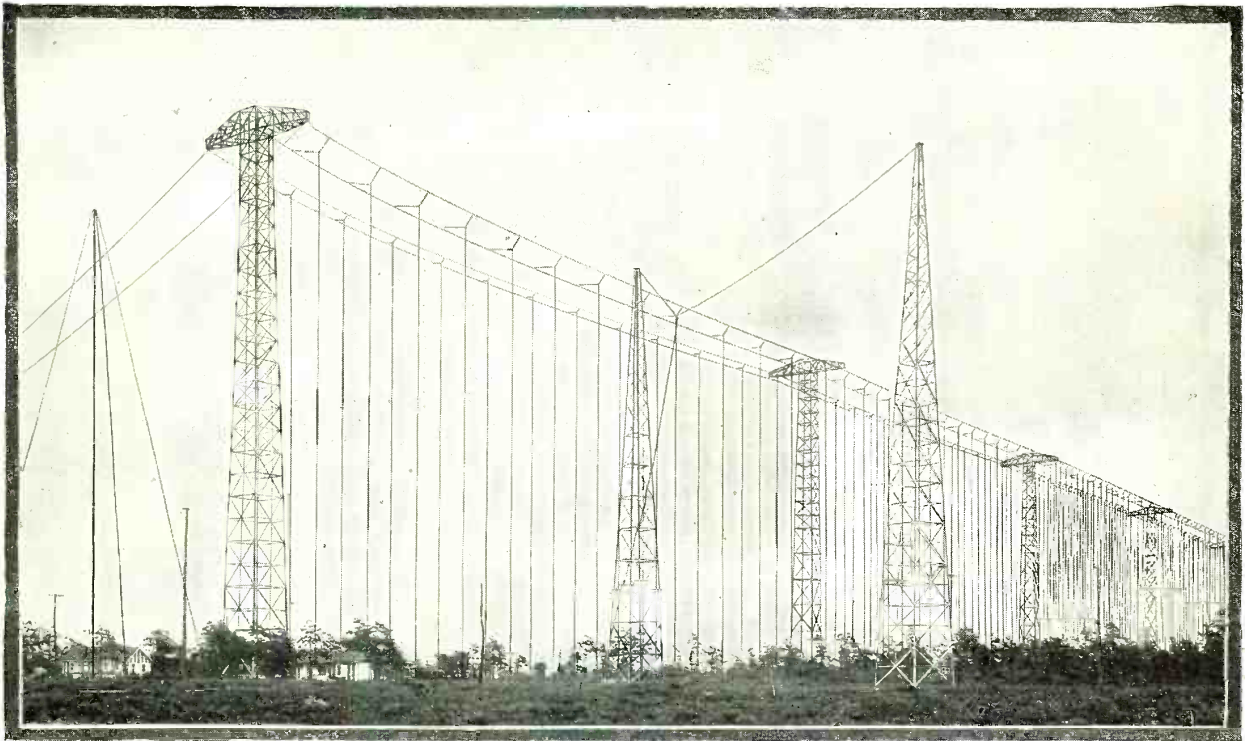

*This unique aerial of vertical wires is designed for the reception of signals from an English "beam transmitter," and is located at Riverhead. One row of wires acts as a multiple aerial; the back row as a reflector which concentrates the radio waves upon the aerial, like a*

*great concave mirror. The energy collected by this system is very much greater than that picked up by an ordinary antenna; and it is therefore possible to get a dependable signal with much smaller power in the transmitting station.*

RECEIVERS AT RIVERHEAD

The receiving end of Radio Central is a few miles west at Riverhead, Long Island. The grounds surrounding the small building housing the receiving apparatus are covered with aerials of every imaginable type. The most outstanding one is a beam receiving aerial of the British type, the construction of which duplicates the transmitting aerial described in the preceding paragraphs.

The receiving house, naturally, is not as spectacular in appearance as the transmitter house, but it contains some interesting equipment. There are 17 separate long-wave receivers, each containing 13 tubes and tuned to a single wavelength. These outfits are arranged in racks, each rack being about twenty-five feet long. In a newly-constructed wing of the room a bank of twenty-four individual short-wave receivers is being installed, about a dozen being in operation at this time. Each receiver contains a total of thirteen tubes and, like the long-wave instruments, each is tuned to one wavelength and left alone. Standard screen-grid tubes of the 222 type are in use in the R.F. stages, three in number.

AN INTERNATIONAL SWITCHBOARD

The outputs of all the receivers are led to a switchboard resembling a telephone board. This is connected by land lines to 66 Broad Street, where the messages from the various foreign countries are copied and routed to their destinations. The radio operators at Riverhead think no more of switching into London or Berlin than a telephone operator in New York thinks of routing a call to Brooklyn, across the river.

While Rocky Point and Riverhead have

been termed "Radio Central" because of the concentration of communication facilities at these points, the Radio Corporation of America maintains other stations for service to overseas countries. The central traffic office at 66 Broad Street in New York handles messages, not only through Radio Central, but also through two Alexanderson-alternator stations at New Brunswick and at Tuckerton, both in New Jersey, and through still another station at Marion, on the south shore of Massachusetts. In addition, another receiving station is maintained at Belfast, Maine, which, likewise, connects directly with Broad Street.

Radiating from New York are direct radio communication channels to England, France, Belgium, Germany, Italy, Holland, Norway, Sweden, Poland, Argentina, Brazil, Colombia, Venezuela and Dutch Guiana. On the Pacific Coast an office in San Francisco handles traffic to Hawaii, the Philippines, Japan, China, French Indo-China, and the Dutch East Indies.

Such have been the developments of a very few years; six since the inauguration of Radio Central, and twenty since the first commercial radio service was put in effect across the Atlantic between Clifden, Ireland, and Glace Bay, Nova Scotia.

*The aerial at the right, which differs considerably in design from that shown at the top of the page, is a part of the "American" beam system; its method of functioning, however, is similar in principle to that of the "English" beam aerial shown above. This, however, is a transmitting aerial, and is so aligned that its emission is concentrated in the most favorable directions. The radio beam is not sharp, like that of a searchlight, but signal strength decreases progressively away from the line of greatest radiation. As in the picture above, one set of vertical wires (those on the left) forms the aerial, and the other the reflector. The length and the spacing of the wires is very carefully calculated, as it must be properly proportioned to the wavelength used, to secure best results. The wires are very rigidly secured to the wooden masts which support them, and kept taut by weights.*

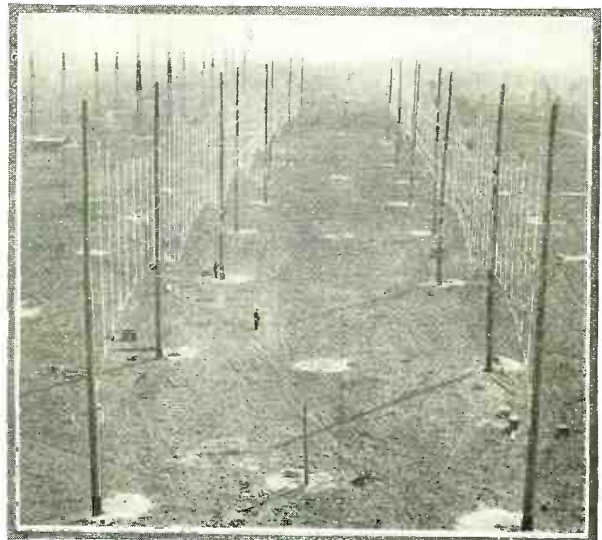

# Getting the Vote by Radio

How the Political Parties Lost Their Hold on Public Interest, and How Radio Presents the Only Method of Restoring Contact with the Voters

By Marshall D. Beuick

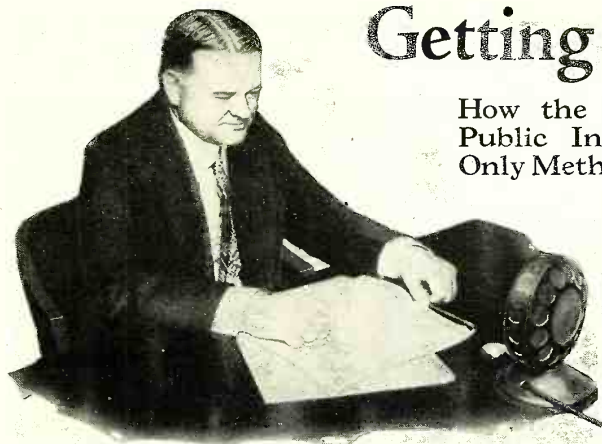

Secretary Hoover has been associated with radio since the birth of broadcasting, and is a veteran of the microphone. He has an effective manner and delivery which many a man in public life may envy.

A get-out-and-vote campaign by radio broadcast stations could do a lot to prod the 40,000,000 voters in the United States who failed to vote in 1926. Those millions represent nearly two-thirds of the qualified voters; for in 1926 there were about 62,000,000 persons who could have gone to the polls to declare their choices of candidates for elective offices.

The National Civic Federation has been working for several years to arouse the indifferent voter who prefers to chop wood rather than go to the voting booth. This organization, in a statement, suggests a job for the broadcaster when it says:

"If the deplorable record of 1926 is to be expunged in 1928, there should be waged an entirely different campaign—not one of platform oratory and publicity stunts alone, but one of real, intensive, individual service."

What, then, could be more effective than an intensive campaign over the air that will reach all the 40,000,000 lazy voters in their homes?

#### RADIO AROUSES INTEREST

The Honest Ballot Association in New York took the initiative in this movement one year, by enlisting the aid of broadcasters in giving information to voters about registration and election. The inquiries received after this campaign was started showed clearly that the broadcast

WILL broadcasting bring the apathetic voter to the polls this year when there is a likelihood of two of the most appealing candidates, Alfred E. Smith and Herbert Hoover, meeting in the political arena to contest for the highest office in the land? Radio has not as yet had a real opportunity to show its pulling power in stirring the interest of voters. In the last presidential election in 1924, broadcasting was young; it was just four years old. This year, for instance, KDKA will celebrate its eighth broadcasting anniversary; for it was in November, 1920, that it first broadcast election returns for the few fans who existed in the country.

The listlessness of the voter has been increasing. An analysis of the number of ballots cast in elections since 1865 gives an interesting interpretation of the political interest, at least, that which is expressed through the vote, over a period of nearly a half century during which there was no such

thing as broadcasting. This analysis shows that the most emotionally-active interest found in politics was apparent in 1876, in the presidential campaign of that year, when about 85 per cent of the qualified electorate cast votes. At the crisis of the Civil War (1864) there was another indication of voter interest, when the percentage was close to 85 per cent.

#### THE VOTER DESERTS

From 1876 the votes sloughed off gradually until 1904, when they dropped rather pronouncedly to about 75 per cent. This decline continued up to 1912, when the percentage became only a little more than 60. In 1916 there was a very slight revival of political interest, which may be explained by the introduction of woman suffrage; and in the campaign of 1920 the vote dropped to its lowest ebb, which was just a trifle above 50 per cent of the qualified voting population.

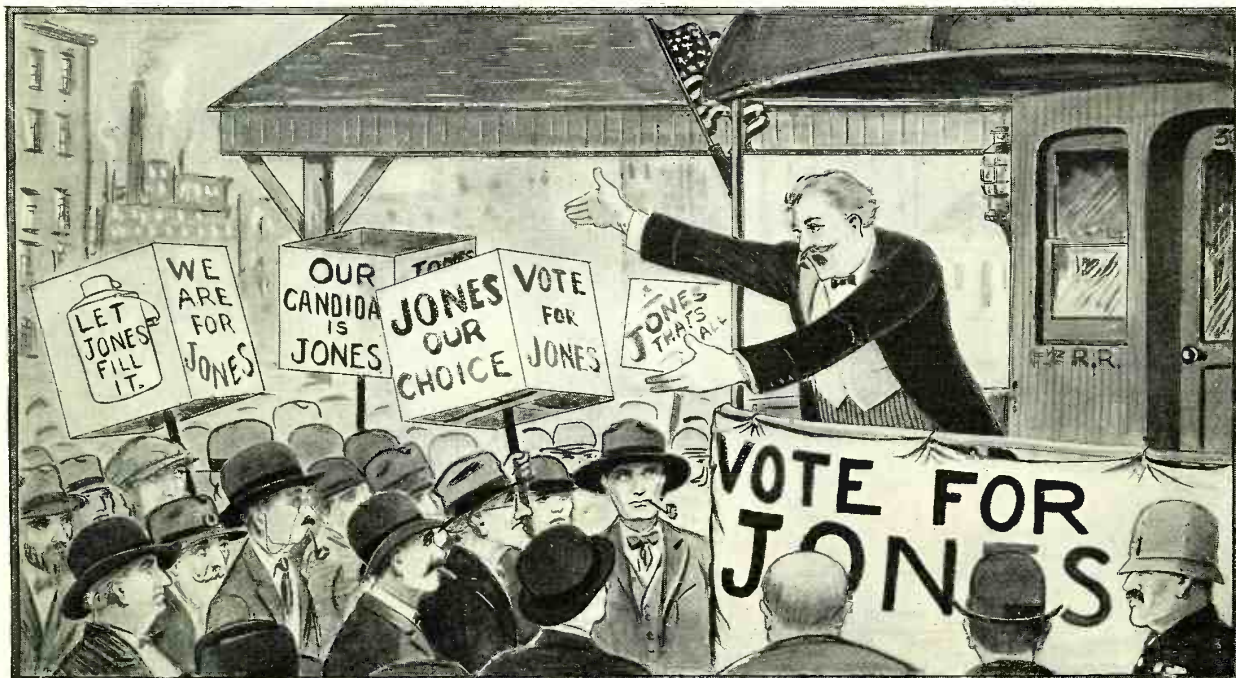

The old-time politician wore himself to a frazzle "swinging round the circle" to reach scattered hundreds—

station is a highly effective means of arousing the interest of the voter and of convincing him that there is no mystery or complexity in taking advantage of his right to vote.

The broadcasting of the proceedings of the conventions of the two parties will be in itself an influential affair in catching the voter's interest. Many of us have remembered for years the voice which repeated, day after day, during the 1924 Democratic convention in New York:

"Alabama, twenty-four votes for Underwood!"

Recall the bands that played. You can almost hear the wild applause of the delegates now, when you stop to remember. Whose blood didn't tingle during those scorching days of that convention, whether he was a Democrat or not? That was a presidential nomination that was being made—a great emotional affair if not one of vital significance to every citizen of the country for the four years to follow.

1928 A RADIO YEAR

Radio has figured somewhat in previous campaigns; but there are indications that this year will give the first full opportunity to show what can be accomplished through broadcasting as the medium of reaching the citizen in his own home. In New York City the radio was used to some extent during the campaign which resulted in the election of James J. Walker as mayor. At that time Governor Smith showed what he could do over the air in reaching the citizens; his informal manner of speaking was entirely suitable to the element of intimacy that broadcasting possesses.

All previous methods of getting out the voter have failed. It is true that the tedious method of calling for the voter at his home is an effective one; but it takes a whole army to do the job even partially. In forty-one states, in 1926, the vote fell off despite the intense non-partisan campaign that was put on throughout the country.

*Governor Smith's informal but convincing style has been felt over the radio in many New York state campaigns which he carried to the voters in this manner.*



This poor showing resulted in the face of the co-operation of a string of important organizations, such as the National Civic Federation, the American Legion, the National League of Women Voters, the American Federation of Labor, the Chamber of Commerce of the United States, and several national organizations of business men.

Literature of all sorts was available in this work, as well as the opportunity at public meetings and the cooperation of some newspapers. Now we have the new situation arising wherein campaign literature will be largely supplanted by broadcasting. "Who reads campaign literature anyway?" is the question of many practical politicians. There is so much printed matter mailed or distributed today that the ordinary citizen can only shake his weary head and throw it away. With broadcasting, however, the situation is different. Such an overwhelming majority of the public listens in frequently in home surroundings where they are more receptive to ideas, that broadcasting appears to be the most effective political instrument. It may very well reduce the campaign rallies to occasional powwows which, after all, will be broadcast.

AUDIENCES OF MILLIONS

The advantage to the candidate is tremendous. Whereas he formerly traveled

thousands of miles, and made hundreds of speeches from the rear end of trains, he can now reach millions through one mike. What he may write will never have in it the personality that his speech over the air will have. The written words of a candidate can be insincere; but it is difficult to cover up bunk when you are talking "mike-to-speaker," which is so much like talking face-to-face.

Someone once said, "Now is the time for all good men to come to the aid of their party." This year it will be the time for all good men to come to the aid of their families and get set for the political broadcasting. If they all do, we shall probably see much more balloting than formerly. Many of those 4,000,000 voters may get so pepped up through the convention contests and other political-radio activities that you can't keep them from the polls in November.

Broadcasting will have its chance this year to show its stride as the modern soap-box for the political speaker.

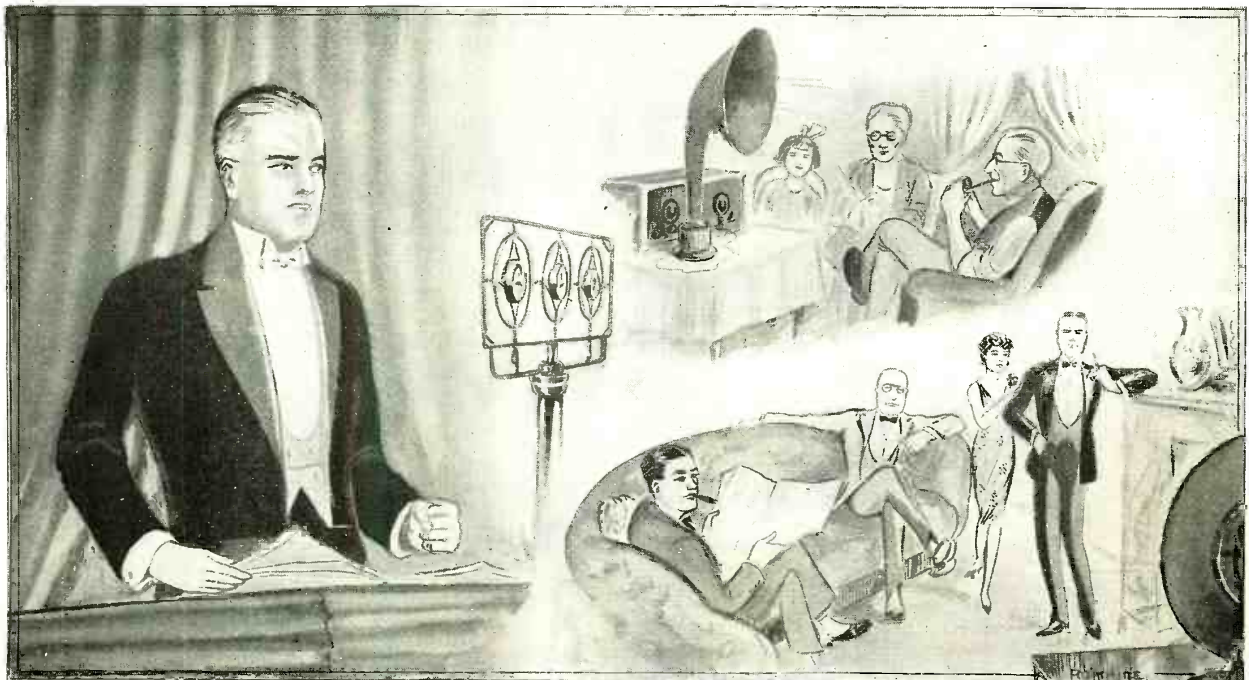

—While the modern candidate addresses millions in a night, through the broadcast chains, with ease.

# Radio Advertising Does It Pay?

Merchant Prince of the Air Says "Be Yourself" is Secret of Success in Direct Selling Through Microphone

By Orrin E. Dunlap, Jr.



"The Friendly Farmer" doing his stuff for his huge, appreciative and responsive Mid-Western radio audience.

"In the Sweet Bye and Bye," "Onward, Christian Soldiers," and so forth. But the ace of the air is Mr. Field in person!

## SUITING THE PUBLIC TASTE

If direct selling ever spreads to other stations, the advertising agencies will probably strive to write the broadcast copy for tooth paste, airplanes, automobiles, ginger ale and everything under the sun. The best copywriters will be put to work and the announcer with the trained voice will go on the air to act as the salesman to put the message across!

"That's what you New York fellers will

**I**S radio's destiny to be direct selling? Is the emptiness of space to become a world-wide billboard upon which electric waves etch invisible lettering that receiving sets and televisors will reveal as blazing signs that everyone "who runs may read?" These are the questions that are puzzling the broadcasters. Congress is pondering over direct advertising on the radio while formulating laws for the future; and national advertisers, ever alert for new and novel methods of introducing and keeping their products before the public, are wondering if they can sell through the microphone without loss of good-will. So far, the broadcasts are softened by such phrases as "sponsored by—" or "by courtesy of—" The announcer does not say "paid for by—" But the great question today is, will direct selling be allowed and tolerated on the radio?

In the first place, does direct selling on the radio reap as bountifully as it is sowed to the four winds of heaven? To answer this one must turn to Henry Field, "the friendly farmer," "seller of seeds," "go-getter" and owner of station KFNF in Iowa, out where the corn grows tallest. He is the past master at selling on the radio.

Let's see what the owner of another station in Iowa says about the pioneer merchant of the air.

### FRIENDS AND FOES

"He goes over big," said the manager of a station which might be considered a competitor as far as entertainment is concerned: "A listener is either dead against Field or he turns on the loud speaker and lets Henry come right up to his fireside with direct sales-talk and bargains. The majority in the Corn Belt consider him a friend but, should his waves reach New York, they would probably be given a cold shoulder and be tuned out. Henry is a showman as well as a salesman. He knows what the public want. He gives them the old fiddlers, devotional exercises, the sweet twitter of the seedhouse canary and the old classics that touch the heart with their melodies. He broadcasts a news digest and then confides with his listeners for an hour regarding the mail he has received. He becomes a friend, who can sit down

in his shirt-sleeves before the microphone and tell the millions all about his seeds, bacons, auto tires, pig meal, fresh hams, radio batteries, prunes, paint, tea, coffee, shirts, shoes, socks, sparrow traps, over-

**S**OME years ago, when the wonders and possibilities of radio burst into the consciousness of the business world, its first thought was "At last—the universal advertising medium." Staid leaders of the advertising profession immediately rebuked the audible thinkers; first, said they, for an unethical idea, which would invite public condemnation, and secondly, for the folly of spending money where there could be no possible return.

Nevertheless, those who were unawed by these arguments went ahead and created the enormous and unrivalled broadcast organizations which are entertaining the American listener tonight—all in the belief that the advertising value of radio will justify an investment of many millions.

Surely, some of them were too optimistic and some too unskillful; money was spent without proper planning, as in all other forms of advertising. To create the technique of a new art, as much money had to be spent as to develop the apparatus which has made broadcasting and its reception possible.

But the American public has not resented radio advertising so much as its self-appointed guardians predicted. The radio advertisers who used the necessary effort—and brains—to please their audience and patrons have enriched themselves in many cases—none more striking than the subject of this article.

The answer to the question at the top of this page is "Yes!" Radio advertising pays you if you know how to do it. The people who are most concerned with whether advertising is good or bad (from the listeners' standpoint) are those who patronize the advertiser if his program is good and who tune him out and buy elsewhere if it does not suit. The answer to the radio advertising question is automatic.

The only complication is "stray" circulation—distant listeners who hear a station outside the area within which its advertising is acceptable to its service audience. And that is a problem, not of advertising, but of all broadcasting—that the "interference" area of a station is so very much larger than its service area.—EDITOR.

all, chicken feed, Bibles, ladies' and gents' hosiery and what not. His waves spread over Iowa, Nebraska, the Dakotas, Minnesota, Missouri, Kansas, but they strike with the greatest force in Iowa and Nebraska."

One secret of Henry's success is that he appeals to the farmers. He is one of them. He knows what they most desire. There are no Metropolitan Opera stars to grace KFNF's studio. Home talent entertains and actuates the microphone with "Swanee River," "Silver Threads Among the Gold,"

do if it comes to selling on the radio," said a westerner: "That's where you'll make your mistake. But you'll wonder why you can't sell a carload of hams or thousands of bottles of ginger ale. The trouble is that you'll talk over the heads of the public. You want to remember that the radio audience belongs to the masses, and you know they say that the average mind is that of the fourteen-year-old child. So why not learn your lesson now and be one of the crowd just like Mr. Field? He never writes



his speeches or sales talk. It's all inspirational and informal. That's what makes friends. This high-brow stuff on the radio doesn't count. That's why Henry has extended his mail-order business. He knows his public and he knows his stuff. He tells the farmers in the Corn Belt that his sopranos sing as God intended, free of the screeching caused by long training. They sing like the common people. The KFNF artists sing the hymns as they ought to be sung, just as anyone in the farm house sings them in church on Sunday."

Mr. Field began broadcasting in Shenandoah in 1925, when his gross sales were \$900,000 for seeds and nursery products. In 1927 the gross sales are said to have leaped up to \$2,500,000, of which \$1,500,000 was for general merchandise. In less than eight months he sold \$340,000 worth of automobile tires. In six months he disposed of \$50,000 worth of shoes over the air, without the bother of having the customers come to the store and try them on. That's salesmanship!

It is reported that he has disposed of as much as a carload of coffee a day, some of which warmed up pilgrims at the studio, where he gives each visitor a cup of coffee. During a flower show he staged, more than 31,000 visitors came to the KFNF studio to catch their first glimpse of the elusive radio and of their friend Henry Field. The population of the town is only 5,000. Hams and bacon he has sold at the rate of half a carload a week. Henry is the Merchant Prince of the Air. He is the Roxy of the great open spaces!

#### HIS SECRET

At a luncheon of the advertisers at Des Moines, Mr. Field told those who seek fame and fortune by selling to invisible customers that the secret of success is "Be Yourself." When talking over the air he dispenses with his coat, just to be one of the common people. Then he chats with his "folks," with such phrases as "we was" and "we ain't got." He has cast aside all "hifalutin" ways.

Henry Field has voice personality and sincerity in his nasal twang. When he begins to sell this is what he says, "Howdy, folks. This is Henry, Henry Field talking, folks. Henry himself."

Then perhaps his voice weakens a trifle as he turns from the microphone to ask Sally, "What's your next number goin' to be?" How different from the prim voice of a New York announcer's "Good evening, ladies and gentlemen of the radio audience."

Henry Field's broadcasting studio is a modern version of the old-fashioned farmhouse parlor and he appropriately calls KFNF the "Friendly Farmer station." On one birthday celebration on the air Henry received 226,000 telegrams, to say nothing of the sacks of congratulatory mail. So much for the sage of Shenandoah, who strives to be one of his audience, "just a friendly, neighborly bunch of folks" who care little for the "hifalutin" things in life.

#### THE FIGHT ON ADVERTISING

But what does the radio law say about making a marketing place of the ether? At a congressional hearing, Federal Radio Commissioner F. O. Sykes was asked regarding the policy to be pursued toward a station "spending most of its time in advertising."

Judge Sykes replied, "There is no authority under the law for the commission to regulate direct advertising (*i. e.*, where the price is mentioned), but I understand that it has been suggested that such advertising be limited to daylight hours."

The Radio Act of 1927 stipulates (Section 19): "All matter broadcast by any radio station for which service, money, or any other valuable consideration is directly or indirectly paid, or promised to or charged or accepted by, the station so broadcasting, from any person, firm, company, or corporation, shall, at the time the same is so broadcast, be announced as paid for or furnished, as the case may be, by such person, firm, company, or corporation."

Some consider direct advertising on the radio an evil. Others contend that it falls in with the provision of the law that broadcasters should have as their slogan, "public interest, convenience and necessity."

Radio Commissioner Orestes H. Caldwell, of New York, calls attention to the fact that the commission has no power of censorship under the law; and he has testified that, in his opinion, direct advertising in many instances provides a distinct service to the listener.

"It is my belief," said Mr. Caldwell, "that nearly every program that goes on the air has a background for some form of publicity. It would be hard to draw a line between those stations which advertise directly or indirectly and those that profess to furnish programs of cultural value."

Mr. Caldwell said that he thought it would be unwise to attempt to censor by law. Programs, he asserted, that are in any way objectionable to the listener will

in time be withdrawn by the force of an adverse public opinion.

Contending that the present law is adequate to suppress direct advertising by radio if the commission should elect to follow such a course, Representative Wallace White of Maine said:

"The commission, generally, may prescribe the nature of the service which a particular station is to render. I am inclined to believe that the language of the law is broad enough to say that, on this particular station, you may or you may not put out advertising, direct or indirect. I have felt that there were doubts as to the soundness of that construction, and for that reason I have brought the question forward for the committee's consideration."

Most of the broadcasters contend that they are not making a profit. Is that because they are not radiating direct advertising? Will necessity force them to change from indirect and good-will programs to direct selling and quotations of prices through the microphone, in order to survive? Time will tell whether or not the "impresarios" in the lavishly-decorated studios with their tapestries, statues and trimmings of gold will come down off their "hifalutin" perch and just be "one of the common people."

However, radio is a big field, the ether is vast, the audience is countless, the tastes are many; so some may broadcast from studios of gold while others entertain from the old-fashioned farmhouse parlor. But, to be successful in advertising, in selling and in making friends, they must learn the simple formula of Henry Field—"Be Yourself."

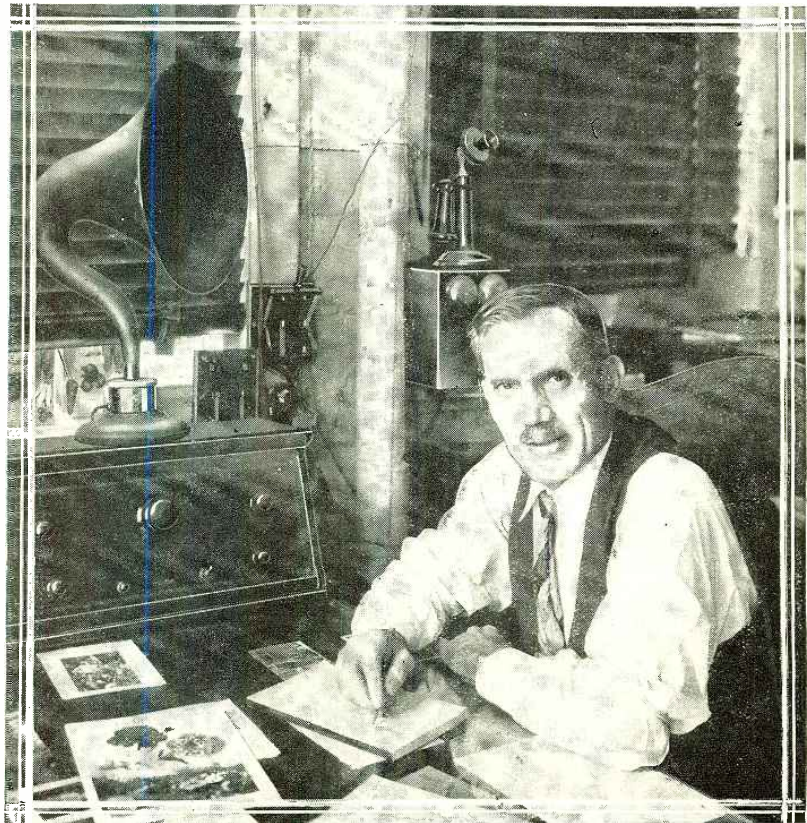

Henry Field of Shenandoah, Iowa, whose station, KFNF, broadcasts his personality—and his mail-order business—to millions of listeners daily.

# Rain, Rays and Radio

by C. Sterling Gleason



**B**ATTLING with hardships, dark discouragement and terrible trials, and urged on by the adamant will, the calm confidence, and tender sympathy radiated from the powerful personality of Harold Dare, certain members of the staff of the Dare studios came at last to a little valley high up in the dry, rarefied atmosphere of the Sierras. They came not for personal glory, nor with mercenary intent, but to gratify the life dream of the great and benevolent Harold Dare.

For years the great screen star had been saddened by the trials and tribulations of the poor, downtrodden working class. His heart went out to the helpless, struggling parents, endeavoring to rear and educate the rising generation, trying to catch a few crumbs from the table of the more fortunate. His heart bled for the children of the sordid city, imprisoned by environment with temptation and evil, filth and disease. Here, in this wonderful valley, would he build a model city. Here the air, dry and clear, was pure and filled with life-giving oxygen and ozone. Here not a drop of rain had fallen for years, yet the fertile valley abounded in springs of clear, cold water rich in vitamins and nuxated iron. Here the sun, shining unremittingly at least 365 days each year, filled the air with health-building ultra-violet rays, infra-red rays, and X-rays. The place had long been inhabited by a race of powerful-muscled Indians of great strength and huge chest expansion. They called it "Um-pah," meaning "land of clear sky and eternal sunshine."

When scientific research had shown that this spot was indeed the long-sought health paradise, Harold Dare's millions worked wonders. Soon many cottages nestled on the hillsides, and mingled with the shouts of happy children echoed the blows of the hammer, as on the floor of the valley a new studio for the Dare films neared completion. No longer did the workman return, tired and discouraged, to a bedraggled wife and pale, wan children; for with the wonderful atmosphere and ideal sunshiny climate, Mother Nature wrought miraculous cures. So was the great dream of the illustrious and beloved Harold Dare being encompassed.

Suddenly the heavens opened their floodgates. Rains of unprecedented violence fell, materials to the value of thousands of dollars vanished in the swirling waters. Construction work of all kinds was halted. Murmurs of discontent began to be heard among dwellers of the valley, as pneumonia and influenza stalked in the wake of the dampness and cold.

Keen-nosed newspaper reporters, scenting profitable scandal, seized upon the situation. Headlines shouted:

## Dare Health Haven Hoax, Charge Hurlled —Probe Dare Poor People's Paradise

The public's confidence in their great benefactor began to waver. Unprincipled demagogues appealed to the jealousy of the misguided masses; calculating editors of the predatory press played upon the prejudices and the passions of the plain people;

viewing with alarm the situation, seeing in it a menace to the public weal, hinting that Harold Dare had betrayed the public confidence. To these accusations, Harold Dare could make no reply. Puzzled, perplexed, with his best experts baffled, in his great soul he blamed himself for this error of judgment. Was his engineering staff's interpretation of the results of their research at fault? Or had a fickle Fate frowned upon his long-cherished plan for uplifting his public?

A new plaint swelled the chorus of criticism. Radio listeners began to complain that radio reception was impossible during the rains. For some time previous to each storm, broadcast signals began to weaken. At the same time, a continuous barrage of static settled down over the whole radio spectrum. With the fall of rain, signals entirely disappeared and Health Valley was totally cut off from radio communication with the outside world.

The local radio listeners' club held a stormy session. Tired fathers, their faces drawn and haggard and their eyes encircled with dark rings, testified that they had been forced to walk the floor all night, for their radio-raised infants strenuously refused to go to sleep without their accustomed bedtime story. Brides were forced to resort to delicatessen fare, since radio recipes were not forthcoming. Tired business men, their muscles grown flabby and soft without the stimulus of radio setting-up exercises, forsook the golf links to play checkers or tiddlwinks. Wives and servants alike threatened to leave at once if radio entertainment was to cease.

As to the cause of the trouble, many theories were current. Some contended that sunspots were responsible; others that the earth had slipped in its orbit. One of the club's experts maintained that in coming through the rain-drenched upper atmosphere, radio waves became so highly damped that they lost their carrying power and were unable to reach the valley. The meeting finally resulted in a petition to the Radio Commission that radio service be resumed without delay.

From the executive offices of Harold Dare came the command to the Dare laboratory staff to make a comprehensive survey of the situation. Forthwith the valley became alive with scientific experts. Putteed surveyors in broad-brimmed hats peered in all directions through their transits. Aviators circled ceaselessly above the valley region, photographing and testing with various radio stations. Geologists went about with their hammers, knocking everything. Meteorologists sent up thousands of balloons to explore the upper atmosphere; astronomers and mathematicians collaborated to determine if any conjunction of planets or



"A sudden patter of raindrops caused him to look out of the window. Absent-mindedly he raised the fluoroscope to his eyes. 'Himmel!' he gasped. 'This is strange!'"

other celestial aberration lay behind the climatic cataclysm. Linguists harangued the stoic Indians, archaeologists squatted for hours over tribal records on rugs, pottery, and stone, in an effort to discover some parallel occurrence in the history of Health Valley.

When, a week later, the Dare engineers met in conference to report their findings, the atmosphere was one of intense gloom and discouragement. The results of the investigation were highly inconclusive. The archaeologists had found one clue, a picture scratched on stone; but because of its crudity, it was impossible to decide whether it was a tribal record of a heavy rainstorm or a portrait of a man taking a shower bath. One expert contended that these Indians had never seen a shower bath; whereupon a colleague tartly called attention to the fact that apparently none of them had ever been out in the rain, either. The grizzled Chief Standing Pat assured the linguists that in all the many moons within the memory of his people, no water had fallen from the skies. His son, young Running Bluff, contradicted the statement, loudly boasting that he had often seen water fall from the heavens at the command of the tribal medicine man, and that he, himself, could command it to do likewise, if he chose. However, he did not choose, and so the linguists were left in doubt.

The sensation of the evening was the report of the Intelligence division. According to their report, two hikers had made the ascent of Peril Peak just before one of the rains. They had just reached the summit when the storm broke. Rain fell in such torrents that only with the greatest difficulty were they able to maintain their footing. But, although the whole valley was being deluged, on all sides the surrounding mountains were in bright sunshine. The

storm clouds seemed to have massed at this point and discharged their entire burden of moisture upon Health Valley. The detectives had no comment to make other than that the integrity of the two hikers was above all question.

Then Harold Dare suddenly rose to his feet. "Men," he said, "from the first I have had a feeling that something more than a freak of Nature lay behind this mystery, that a human hand somehow was directing the sinister turn taken by this cataclysm, threatening as it does to undermine the very foundations of our civilization in Health Valley.

"There is one person who would move heaven and earth to work me harm. That person is Dandy Diavolo, my arch-enemy of the Flicker Films, who pursues his role even more relentlessly in real life than before the camera. He alone would stoop to strike at me in such a way. It is my theory that he is beneath this demonstration of storm and strife. If so, he will soon endeavor to make his triumph complete. We may therefore look for another rain in the near future; and this time we must discover the means used by the monster. 'Carry on!' must be our motto. Carry on! until in the very last episode, right shall triumph, and villainy receive its just reward!"

\* \* \*

It was with a strange thrill of fulfilled prophecy that the Dare engineers looked up one morning to see that the sky was becoming overcast and that huge dark clouds were massing themselves overhead. From Peril Peak, where a lookout station had been established, came the word that the air was warm and humid, and that clouds were moving in from all directions and converging upon a spot directly above Health Valley. And when Assistant Engineer

Wynn, in charge for the time being of operations in Health Valley, stepped into the Dare radio-telegraph office to summon Scott, who had returned to Hollywood on business, he found a group of experts gloomily inspecting the radio transmitter.

"It's no use," said the operator in charge. "About an hour ago, the static shut down and we have not since been able to break through on any wave. Our only connection with the outside world is by long-distance telephone."

At the same moment, in a room of the huge Dare hospital across the valley, Dr. von Stück, fluoroscope in hand, was conducting an X-ray examination. A sudden patter of raindrops caused him to look out of the window. Absent-mindedly he raised the fluoroscope to his eyes.

"Himmel!" he gasped. "This is strange!" In the fluoroscope appeared a cluster of wavering, striped streamers radiating from a bright spot in the sky where the clouds were heaviest. For a moment he studied the phenomenon, and then stepped into the adjacent office and picked up the telephone.

\* \* \*

Across a hundred miles of mountain and canyon, river, plain, and desert, guided only by a pair of tiny twisted wires, thrilled tiny quivers of electricity—now through the dark tunnel of a lead-sheathed underground cable, now across the intricacies of a huge telephone exchange, to a room where a man sat before the control panel of a radio transmitter and shaped the meaning of the tiny impulses into the clicking of a key. Out from a slender web of wires swung between tall towers, waves rippled the ether; and high up above a panorama of peaks and valleys, the radio operator of Harold Dare's private air transport handed

(Continued on page 175)

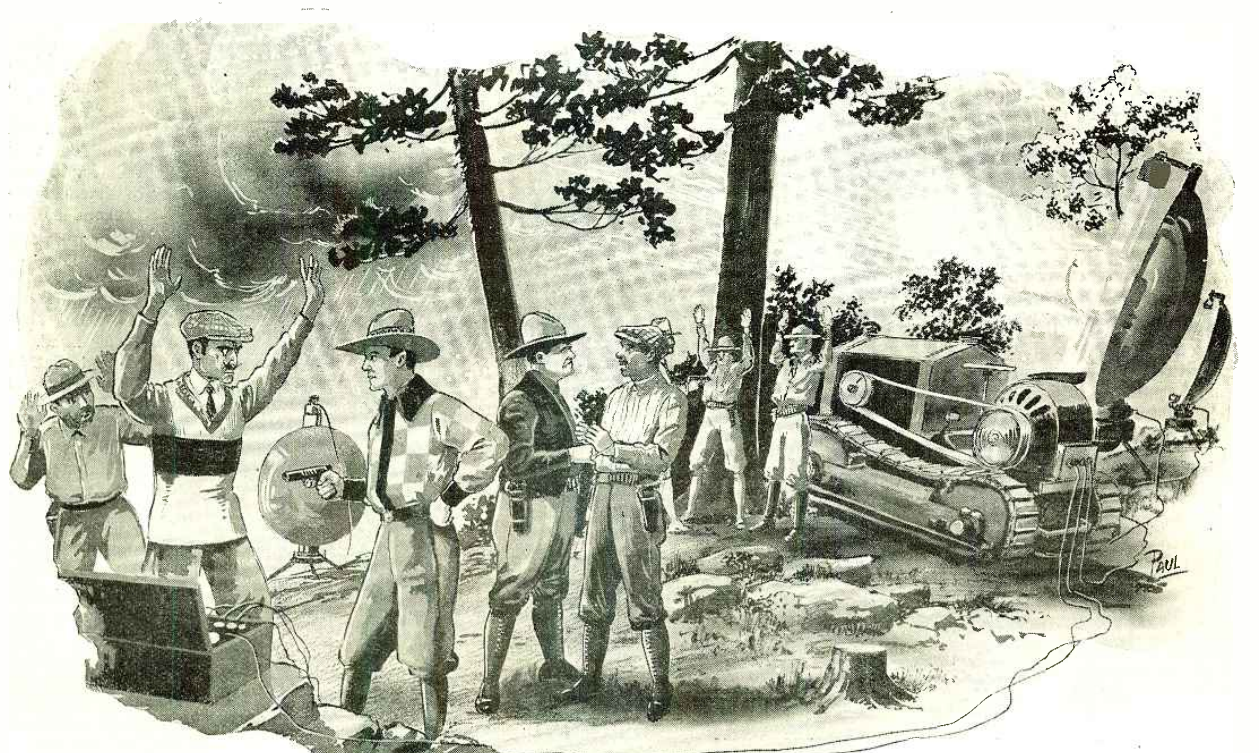

"The rest of the story belongs to history: how the Dare forces, under the courageous leadership of Harold Dare himself, went out into the hills, surrounded and captured Dandy Diavolo and his henchmen; and how they found cleverly concealed in the underbrush a dozen huge, mercury-vapor arcs."



## More About Gyps

Editor, RADIO NEWS:

The article on the "Radio Gyp" in the June issue of RADIO NEWS is a step in the right direction, but why confine it to Philadelphia? It might well be spread from one end of Cortlandt Street to the other in at least some of its phases.

The practice of trying to substitute tubes for those advertised is prevalent in all of the stores, even the so called high-class ones. They all have the same story; it sounds like a correspondence course; "The Cunningham (or RCA) is a cheap tube, let me show you the "Gypatron" for only 50c more which is absolutely guaranteed"—(try and realize on the guarantee.)

O. C. MOOS,  
FRED J. DEESEN,  
R. E. LOCKE,  
E. V. INGLET,  
J. P. DUFFY.

Southern Pacific Company,  
165 Broadway, N. Y. C.

Editor, RADIO NEWS:

Allow us to congratulate you on your expose of the "Gyp" store in your June issue of RADIO NEWS. Keep up the good work.

Modern Electrics started us in 1908, and we're still at it. The retail business is rotten for the small dealer, and your article on the Parker gang in Philadelphia gives us a slight ray of hope that the fakers will all be in a class with the spark sets of by-gone days.

HARRY FREUND,  
Pioneer Radio Service,  
1686 George St., Brooklyn, N. Y.

## Who Will "Bell the Cat"?

Editor, RADIO NEWS:

I believe that, if the radio listeners of America were organized, they could compel the enactment of legislation that would give them the greatest benefit from radio. These listeners are now standing by, patiently waiting for some one to say "Let us organize"; and this "someone" should be the radio publications of America, because their prosperity depends upon the broadcast situation being cleared up to the entire satisfaction of the radio listeners.

The object of the organization will be to make conditions such that every radio listener in the country will be able to get just what he desires over the air and with the clearest possible reception. (*Hitching the wagon to a star.*—EDITOR.)

As to clearing up reception; we will have to eliminate man-made interference, such as station interference and that produced by defective electrical appliances. Static will be counteracted by increasing the power and by a more even distribution of stations

over the country. Station interference can be eliminated by one or more of the following ways: Spreading stations over a larger waveband, division of time, placing chain programs on the same wavelength if this is possible, improving broadcast and receiving apparatus, and as a last resort, by eliminating some of the stations. Interference produced by defective electrical appliances can be eliminated by the necessary state legislation.

The radio listeners of America can be

---

*THIS page belongs to the readers of RADIO NEWS. It is theirs for the purpose of discussing fairly and frankly the needs of broadcasting from the standpoint of the great public who listen in. The letters represent, not necessarily the editorial opinion, but that of the writers; who are, in the editorial belief, fairly typical of groups of opinion among the radio public. Make your letters concise and offer constructive criticism when you can; remembering always that there is something to be said for the other fellow's side.*

Address The Editor, RADIO NEWS,  
230 Fifth Avenue, New York City.

---

organized if our radio publications will devote space to explaining the merits of such an organization and at the same time calling on their readers to become members. A membership fee of 25c per month will be required and each applicant should be requested to pay for as many months in advance as his pocketbook will permit, in order that heavy advertising be carried on in the different radio publications and over the air. That is, we must pay as we grow and, of course, the more we pay, the faster we will grow and the sooner we will reach the stage at which we can enforce our demands.

Each applicant from an unorganized district should state at the time if he will donate his services as a local secretary or organizer. From this information, the national office will appoint temporary local secretaries and organizers for each district. When the membership is large enough, the national office will establish state and city branches which will be financed by receiving a part of the membership fees. The required state and national legislation will then be drawn up in proper form and turned over to the local organizers to circulate for the required number of signatures. These petitions will then be put through the proper channels by the secretaries of the districts to which they pertain.

EDWIN H. WHITE,  
Dos Cabezas, Arizona.

(All organizations must creep before they

can walk. An attempt like this, to form a national organization from the top, would be a gigantic undertaking. A federation of clubs formed of local listeners, as they grew, would be the natural method of evolution.—EDITOR.)

## Troubles We Make Ourselves

Editor, RADIO NEWS:

As I read "The Listener Speaks," I see some good suggestions; but they seem to be all for station managers. I will gamble that some who have complained about reception have different home appliances causing interference.

The first step toward good reception is to have the listening public as a whole unit, instead of its being divided into decimal fractions. Regardless of what type of program is preferred, the first step is to clear the air of 60% of the interference due to household appliances. As I write, at 3:00 p. m., some of my kind neighbors have gone out, and their vibratory charger is on, and will stay on until their return—usually about 10:00 or 11:00 p. m. Usually, when one vibratory charger stops, another starts in retaliation; and the majority suffers as a result.

When one has over 80% amplification at 50 cycles, and a speaker that will reproduce that frequency, the 60-cycle vibrator gives a roar that can be amplified enough to saturate the last audio tube.

We had a "Clean the Air" movement here, but as soon as it was found out that it would cost a couple of dollars, it was dropped. Let the majority of listeners demand of their respective city councils ordinances forbidding the use of such articles without suitable filters in the line. The power companies will tell where they are; and the public will be surprised to find that "the transformer on that pole" has suddenly become quiet without being fixed.

The next step will be to demand that an engineer be put in charge of the Federal Radio Commission—someone with backbone enough to make the different stations bring their apparatus up to standard and keep station distortion down to a minimum. I had a good laugh when I saw a picture of a very expensive station using an R.C.A. 20 to check their programs with. The general trend of receiver design seemed to be competition in quality of reproduction until the advent of the A.C. tubes; and then something had to suffer in order to keep the hum at a minimum. Squeals we had all become used to.

Engineers published charts showing response curves of different amplifiers and speakers, told us what was going right over our heads, unless we had similar apparatus. We bought it. Now we get a station hum

(Continued on page 179)



# Broadcastatics

### OUR COUNTRY'S HERO

JONES: "What's all the crowd for? And who is that fellow they're cheering so?"  
 SMITH: "Haven't you heard? That's the man who has just invented a radio set that will always work when you have company in to hear it!"  
 —Leiland Seay.



### CORRECT! GO TO THE HEAD OF THE CLASS

TEACHER (who is working up to a lecture on the wonders of radio): "Can any of you name to me something that talks, sings, plays, that was not in existence twenty years ago?"  
 HANDY ANDY: "Yes'm, oh, yes, ma'am!"  
 TEACHER: "What is it?"  
 ANDY: "Me!"  
 —J. Leo Ubry.



### A HAPPY THOUGHT

HOUSEHOLDER (suddenly awakened by noise in night, from head of stairs): "Who's there?" (Clicks gun.)  
 RESOURCEFUL BURGLAR (hoarsely): "This is station IOU, Walla Walla, Washington, signing off. Good night, ladies and gentlemen!"  
 —Albert A. Snyder.



### IT WAS TICKLISH

A radio dealer was waiting on a flapper customer in my presence, and she explained, "My father wants a new radio tube; something's wrong with our radio."  
 "How does he know it's the tube?" asked the dealer.  
 "Because it hollers when he pokes at it with his finger," explained the young woman.  
 —Mrs. R. A. Hill.

### ANOTHER CRUEL SLAM

SALESMAN: "This is the most selective set we have. You can absolutely tune out every station except the one you want."  
 SANDY: "Aweel, it seems tae me 'twould be better, gin ye could get mair than ane. 'Tis nae use wasting guid music when ye ha' paid oot siller tae hear it."  
 —J. Thomas Scott.



### A SCIENTIFIC BLUNDER

PROFESSOR OF PSYCHOLOGY: "Jones, I have come to the conclusion that you have what is known as an 'Inferiority Complex.'"  
 STUDENT (a radio fan): "That's where you're wrong, Professor Floyd; mine is an eight-tube superhet."  
 H. N. Webster.



### HE KNEW THE KIND

Evidence that the "razzing" sometimes given stations by the press comes home was given by an unconscious (or sub-conscious) slip on the part of an announcer at station WGN a few days ago. He was describing a sport of cricket fighting which is sometimes practiced in Japan, and opened his heart to the radio audience.  
 "These critics sometimes are a very blood-thirsty and murderous lot!"  
 —Arvin Carlson.

### "THE EASIEST WAY"

BILL: "I say, old man, are you going to take in the flower show this evening?"  
 JIM: "No. I think I'll go to bed early tonight and get it over the radio."  
 —E. W. Trebilcock, Australia.



### PRIDE GOES BEFORE A SERVICE

MOTHER: "Hurry now, Pa, and get into your Sunday clothes."  
 FATHER: "What for, I ask you. We're not going anywhere today."  
 MOTHER: "Don't argue, I tell you. I'm going to tune in the services up at the cathedral."  
 —E. H. Foley.



### THEIR FUTURE STATE

MOTHER (reprovingly): "Oh fie, Minnie! Do you know what becomes of little girls who tell stories?"  
 ROMANTIC MINNIE: "Yes, Mamma; they grow up and get to be lady story-tellers over the radio."  
 —J. Leo Ubry.

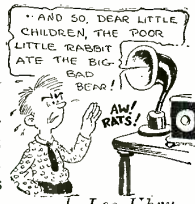

### IN THE NEAR FUTURE?

PHONE HAM: "Say, I just heard a ham in Australia drop a pin! Can you beat that?"  
 TELEVISION HAM: "Huh, that's nothing. I had that fellow tuned in, too, and saw the pin drop!"  
 —J. Thomas Scott.



## RADIO RHYMES.....No. 10



IN RADIO'S EARLY INFANT DAYS A ONE-TUBE SET WAS ALL THE CRAZE.

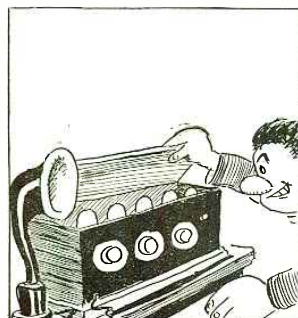

THE ART PROGRESSED-- AND BYE AND BYE OUR TUBES BEGAN TO MULTIPLY

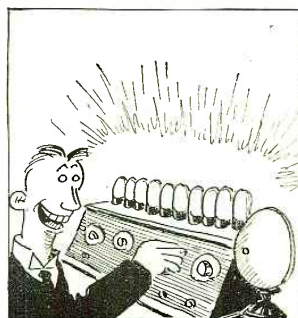

THEN CAME THE ULTRA-BLOOPER-- DWYER THAT BOASTS EIGHT TUBES --- OR MAYBE NINE!



BUT HERE'S A THREE-TUBE SET THAT'S STRANGE-- IT SERVES A WIDE AND VARIED RANGE!

W. LEMKIN



Under this heading, RADIO NEWS publishes each month descriptions of the latest developments in the extremely interesting field of television.

## Radio Movies and Television for the Home

**E**ARLY in May of this year, C. Francis Jenkins, the noted radio inventor, demonstrated in Washington, D. C., his latest system of radio photography, or rather "radio movies," as he prefers to describe it. Using a wavelength of 300 meters, in the regular broadcast band, he transmitted a number of reels of specially-prepared standard-size motion-picture film, while members of the Federal Radio Commission and a number of other nationally prominent individuals looked on. The signals were picked up in the homes of Commissioner Sam Pickard, W. P. MacCracken, Jr., of the Department of Commerce, Captain S. C. Hooper, U. S. N., and William Gibbs McAdoo, where they were converted into light impulses and viewed by the on-lookers through a large magnifying glass.

A private demonstration was arranged later for a member of the staff of RADIO NEWS, who was very favorably impressed by what he saw. The original film showed, in black and white silhouette, a little girl bouncing a ball, dancing and kicking into the air. It was reeled off in front of the radio-movie transmitter at the rate of 15 pictures per second, the pictures at the receiving end being reproduced at the same rate. The images seen through the observing lens at the receiver were, apparently,

about six inches square, and remarkably clean cut. In most of the systems of television and picture-transmission shown up to this time, it has been usually difficult for the observer to determine whether he is seeing the image of a rolled newspaper or that of a man scratching his nose; but with the Jenkins apparatus the definition is so good that the images are instantly recognizable.

The illusion of motion is excellent; almost as good, in fact, as that produced by a regular motion picture thrown on a screen. The received radio images appear with a frequency of 15 a second; whereas regular motion pictures are projected at a rate only one per second faster.

It is the present plan of the inventor to produce the complete radio-movies instrument on a commercial basis and to sell it as an accessory to the regular broadcast receiver, as a device for home amusement. Whether or not a suitable broadcast service will be available is another question, which cannot be answered at this early date because of the unsettled state of broadcast affairs. However, the apparatus does work well, and its possibilities are numerous. There is no reason why it cannot be extended eventually to operate as a true television machine; that is, to transmit (and receive) the images of people as the latter

stand in front of the televisor in the studio.

### THE JENKINS TRANSMITTER

The Jenkins system is quite different from others which have been described in RADIO NEWS. The general layouts of the transmitter and receiver are shown in Figs. 1 and 2, respectively. Unfortunately, no photographs of the transmitting equipment are available, but a number of views of the actual receiver are shown here.

In Fig. 1, the essential parts of the transmitting apparatus are shown in approximately the positions they occupy in relation to each other. The film reels are arranged on a simple framework, one above the other, in such a manner that the film is pulled vertically downward by a set of sprockets which are, in turn, driven by an electric motor. One end of the shaft which drives the sprockets is fitted with a gear meshing with another of only half its size. The small gear is attached directly to the shaft of the motor, which is a synchronous alternating-current machine developing 1,800 revolutions per minute. Because of the reducing action of the gears, the pictures are pulled past the sprockets, or past any fixed point next to the film, at the rate of 900 per minute, or 15 per second.

At the other end of the sprocket-driving

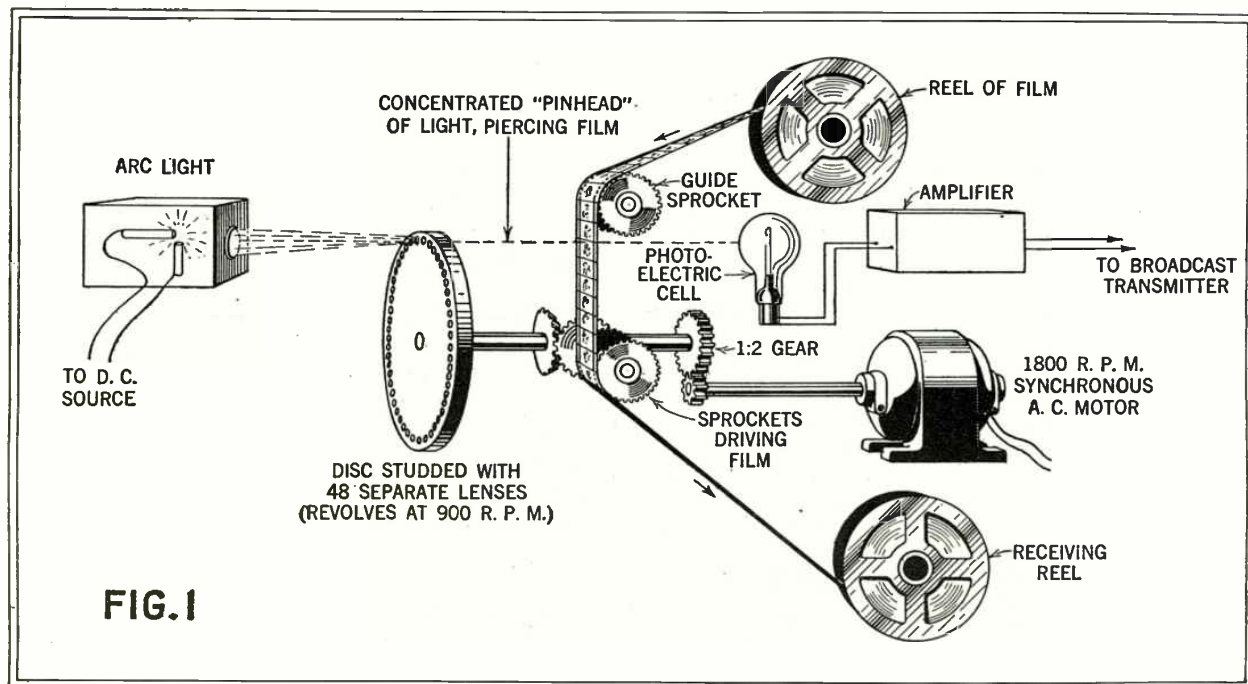

General layout of the radio-movie transmitter, showing the essential parts without the supporting frameworks, etc. The leads marked

"to broadcast transmitter" run to the regular input amplifier of the broadcast station through which the pictures are being sent out.

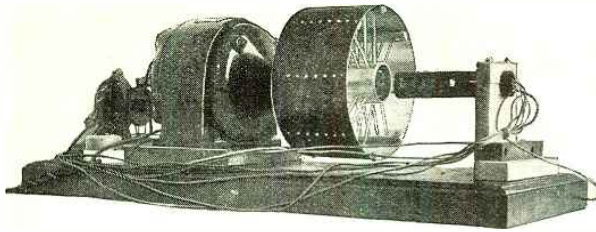

Above: A six-target neon tube and drum, used in experimental work. Right: This illustration shows the neon tube inside the drum, ready for operation. This drum is a four-hole model.

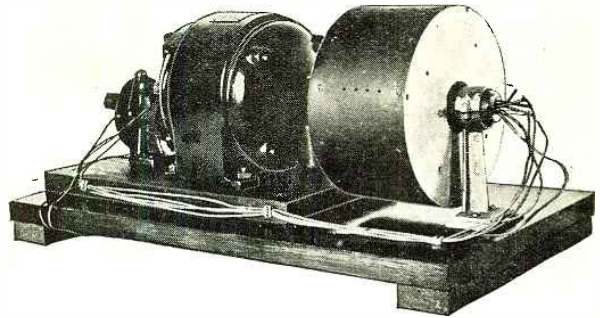

shaft is a heavy metal disc, about 15 inches in diameter and about one inch thick; its edge is studded with 48 separate little lenses, each having an "optical speed" of  $f. 3.5$ . Each lens is designed to concentrate the light from a powerful arc lamp into an intensely-brilliant "pinhead" beam, which is caused to pierce the film as the latter travels down past the back of the disc. This disc is a very carefully-constructed unit; according to a member of Mr. Jenkins' laboratory staff, it cost about \$9,000. The principal part of this expense is represented by the lenses, which are all matched to each other.

Directly behind the film is fixed a sensitive photoelectric cell, so placed that it receives the "pinhead" beam of light projected through the film by each lens. The cell is connected to a three-stage resistance-coupled amplifier, and that in turn to an eight-stage amplifier of similar design. To prevent the amplifiers from picking up external disturbances of various kinds, which would be registered as part of the pictures. Mr. Jenkins has buried them under double copper shields. The photoelectric cell itself is also completely sheathed in copper, except, of course, for a small aperture which is left to admit the light beams. The eight-stage-amplifier shield is fully the size of an ordinary business desk.

SCANNING THE PICTURE

A close study of the apparatus will make its operation clear. The disc is revolving at the rate of 900 revolutions per minute, or 15 per second. The separation between the centers of the lenses is just equal to the width of the film. The film moves steadily down at the rate of 15 pictures per second (its action is not jerky, as in a moving-picture projector). Now let us start with a pinhead of light from one lens piercing through the lower right-hand corner of the first picture on the film. As the disc revolves, the pinhead of light travels horizontally across the film; the instant it runs off the left edge, the beam of the next lens starts at the right again, but at a point a trifle above where the first one started. *The starting point is higher on the picture because the film is moving down at the same time while the disk is turning.* Just as the second beam runs off the left edge of the film a third one starts on the right at a still higher point on the picture. This movement is continuous during the operation of the device.

Forty-eight separate beams of light travel across each individual picture on the film, this operation consuming one fifteenth of a second. At the start of the second fifteenth of the second, a new picture slides

into position and another series of 48 light beams starts to pierce it. All this is obvious, as both disc and film are moving at the same rate; one complete revolution of the disc consumes one fifteenth of a second, and the downward movement of one complete picture through the light beams consumes the same amount of time.

While this movement is taking place, the light beams fall with varying intensity into the photoelectric cell, which produces an electric current that varies with the transparency of the film. This varying current modulates the output of a broadcast transmitter in the same manner that voice and music impulses do in ordinary broadcast. Forty-eight lines of alternate black-and-white areas per picture are "written" into the cell, and by it sent out to the receivers.

THE RECEIVING END

The Jenkins receiver is altogether different from any of the other television and picture machines now in existence. It consists of six essential parts, arranged as shown in Fig. 2. The heaviest unit is a 3,600-r.p.m. synchronous A.C. motor, to the shaft of which is attached a hollow metal drum about seven inches in diameter and about five inches wide. The center of this drum is a hollow spindle with a thin wall.

In corresponding places on the drum and

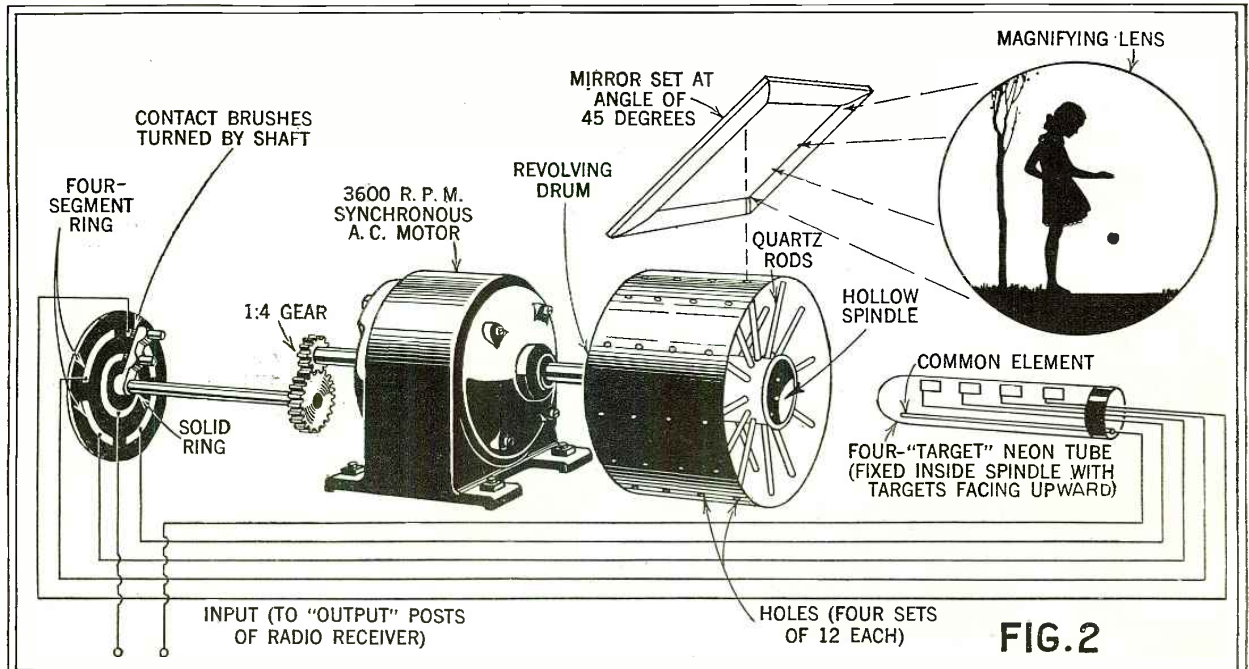

General layout of the picture receiver. The whole lower assembly-line is enclosed in a wooden box, on the top of which are mounted

the mirror and the magnifying lens. The images are viewed through the latter, as illustrated on the cover of this magazine.

the spindle (both outer and inner surfaces) are four spiral rows of tiny holes, twelve holes to a row. A short piece of quartz rod between the outside and inside connects each pair of corresponding holes. The purpose of the 48 little rods is to conduct light from the inner spindle to the holes in the outer drum with as little loss as possible.

Fixed inside the hollow spindle, with the flat little plates facing directly upward, is a special four-"target" neon tube. This tube is similar in general operation to the standard flat-plate neon tubes now sold generally for television purposes, but is in reality a quadruple tube. It is about four inches long and one inch in diameter, the little plates or "targets" being about 1/4-inch square. A straight wire running near the edges of the plates acts as a common element. In Fig. 2 this lamp is shown out of the spindle; in actual use it fits inside the latter without touching it.

The other end of the motor shaft is fitted with a 1:4 reducing gear which drives a revolving switch. The revolving element is simply a pair of contact brushes connected together; one brush effects continuous electrical connection to a solid brass ring imbedded in an insulating disc, while the other makes a wiping contact over the four sections of a split ring. The four segments connect with the four targets of the neon tube, while the solid ring goes to one of the input posts of the machine. The common element of the neon tube goes to the other input post.

All the apparatus described so far is contained in a wooden box about two feet long and a foot square at the end. Directly above the top of the revolving drum is a square opening in the top of the cabinet; over this opening an ordinary mirror is mounted at an angle of 45 degrees to the top. About a foot in front of the mirror,



C. Francis Jenkins (second from the left), showing his apparatus to Commander C. C. Hooper, extreme left; Brig. General George O. Sauter; Carl H. Butman, Secretary Federal Radio Commission; Capt. C. H. Hill, U. S. Signal Corps; and Federal Radio Commissioners Harold La Fount, Ira E. Robinson and Sam Pickard.

standing upright, is a magnifying glass about ten inches in diameter.

The input posts of the picture receiver unit are connected to the last audio amplifier tube of a regular receiver. For his demonstrations Mr. Jenkins used a popular one-dial receiver with an additional power amplifier stage.

REPRODUCING THE PICTURE

Now let us follow through the operation of the receiver: the modulated signal of the transmitter is picked up by the aerial, amplified, detected and again amplified by the receiver, and then led to the "radio-movie" projector. Let us assume that the

contact brushes have just made contact with the upper right ring, as shown in Fig. 2, and that one of the quartz rods in the first (outermost circle) is pointing straight up. This condition corresponds with the start of a picture in the transmitter, just when the pinhead of light is starting to sweep across the film.

As the contact brushes have just closed the circuit to the neon-tube plate at the extreme right, this "target" lights up immediately and fluctuates in accordance with the modulation of the signal. The fluctuations of light are carried up the quartz rods and projected through the holes in the  
(Continued on page 173)

## Television Experiments in Boston Create Great Interest

GR<sup>EAT</sup> interest among radio fans in and around the city of Boston has been created by a series of experimental television broadcasts sponsored by the *Boston*

*Post*, and carried on through the short-wave transmitter of Station WLEX, located at Lexington, Mass., a suburb of Boston. The broadcasts were first attempted during the late part of April, and were continued during May. A number of New England radio manufacturers built the transmitting apparatus and offered for sale the essential receiving components, such as neon tubes and scanning discs.

It is reported that over 2,000 neon tubes were sold within two weeks of the initial experiment. Great quantities of sheet aluminum, for the scanning discs, were also purchased by local radio fans. However, the general results so far are said to have been negligible, practically no individual experimenters having reported successful reception of the broadcast images. The "televised" objects were rolled newspapers and the hand of a man.

RADIO NEWS has been informed by D. E. Replogle, of the Raytheon Mfg. Co., makers of the neon tubes, that toward the end of May the results had been greatly improved, the image of a man's face being plainly discernible. At the time this issue of RADIO NEWS went to press, no further information was available. More detailed reports of the experiments will be published in forthcoming numbers.

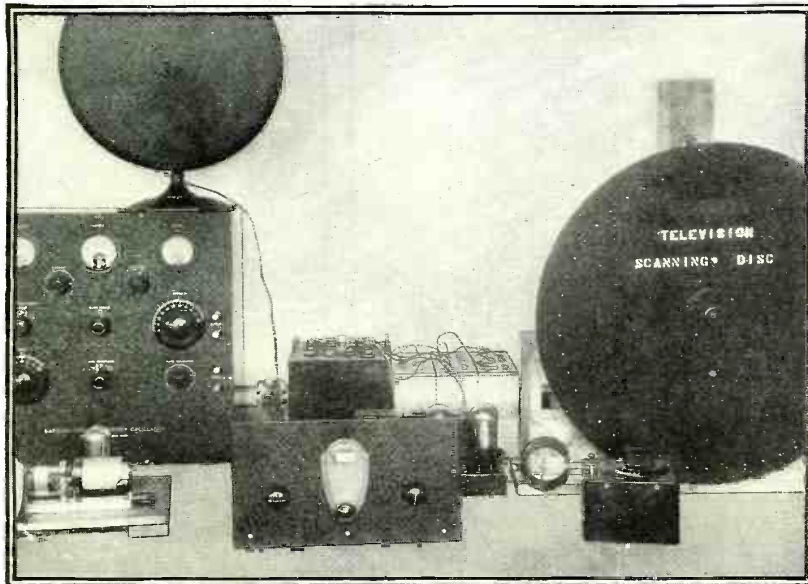

An experimental television receiver set up in the laboratory of James Millen, Malden, Mass.



# Why the Weather Affects Radio Reception

Some Facts and Some Unsolved Problems about the Atmosphere and the Pranks It Plays on Transient Radio Waves



By B. Francis Dashiell \*

**I**F Mark Twain had been a "wireless" operator or a radio fan, he would have been fully justified in making his famous remark that, while everybody always talked about the weather, nobody did anything about it.

In the early days of "wireless" a very disgusted operator threw down his headset and turned to me with the remark, "I hope that some time someone will do something about this weather and climate mixing up with wireless signals." This remark, made on a night when static was bad and distant stations failed to respond to the most alluring adjustments of his detector, expressed for all time the universal and hopeless appeal of all operators and the millions of radio fans yet to come. Even in the first days of wireless telegraphy, there were definite conclusions that the weather and climate had their effect on wireless communication.

Since that night many years have passed. But the conclusions that weather affects radio are firmly entrenched in the minds of radio people everywhere. And still nothing has been done about it in a remedial way. While more data have been gathered and the correlations have become more and more obvious, we still have no sound theories which will stand scientific analysis by the radio engineer and the meteorologist. However, conclusive investigations show that some of these theories must be generally accepted, since they appear quite sound and reasonable.

### STATIC, FADING & CO.

Of all the natural phenomena which affect radio operations, static is the most important for consideration. Static has taken up the attention of radio engineers from the time the first "wireless" apparatus was set up, over 30 years ago. Static will always interfere with radio, at least until some entirely new communication system is invented. No real cure for its persistent

manifestations has been found, except at a considerable loss of signal strength. If static is to be entirely eliminated, we must cease using space and the atmosphere for a transmitting medium, and electromagnetic waves must be replaced with some other form of non-electrical energy.

Besides the annoyance of static, the radio fan and operator has become familiar with

many explanations for the causes of fading, some apparently quite accurate, but no one has suggested a real cure. A cure for fading, except for that caused by certain inherent faults in the apparatus, is hardly likely.

Another matter that greatly concerns radio engineers and meteorologists is the phenomenon of variations in signal intensity from day to day. This is a subject upon which many investigators cannot agree. The theories advanced have not held good in all cases, and the proportion of favorable results about balances the number of failures. This fact leaves the situation open for much discussion and future research, and the proponents of these tentative theories are left in a rather temporizing position.

This has brought us to three great basic kinds of natural radio interference: static, fading and daily variations in distant-station reception. Each is entirely separate; there is no conclusive evidence that the things affecting one will also affect the others. Therefore, in order properly to discuss the effects of the weather on each, it is necessary to deal with them separately.

### STATIC AND ATMOSPHERIC ELECTRICITY

We all know what static is, as far as its effects in our radio receiver are manifest, but it would be quite difficult to attempt to show what static actually is. In fact, the keenest minds of science cannot entirely explain all its ramifications and the reasons for its presence in the atmosphere. That it is a form of stray electric charge, wave or current, is agreed to by all.

One should not confuse static electricity with the atmospheric electricity that is known to exist between the surface of the earth and some point beyond. Atmospheric electricity exists above the earth and has a very definite "potential gradient," increasing normally to some point of elevation where it becomes constant. It is not be-

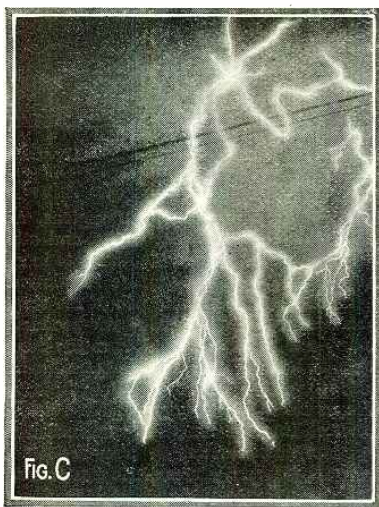

Each of these eight strokes caught by the camera is a transmitter of "static" waves, caught by radio receivers at great distances.

the rapid variations in signal strength, or fading. There has been less observed obvious relationship between signal fading and the weather than in the case of static. Fading signals from a broadcast station are not at all regular; for on one night the fading will be bad, while on the following night none will be noticed. Scientists give

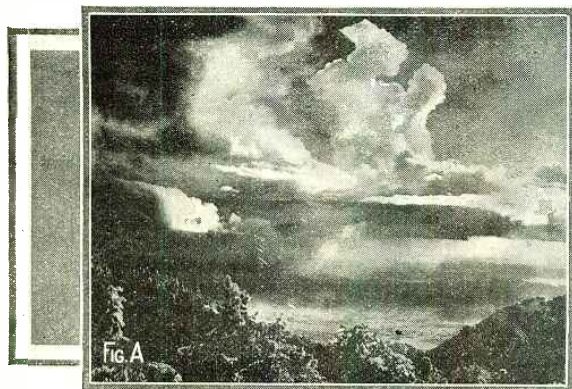

Here is a thunderstorm, as seen from a neighboring mountain. The air is charged to a high voltage, discharges are frequent, and resulting "static" is severe. (Photos by U. S. Weather Bureau.)

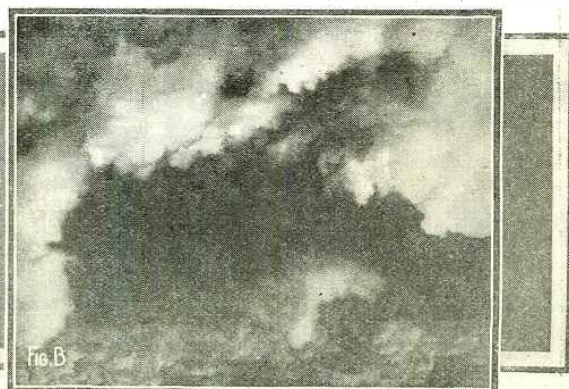

These clouds are highly charged, and as they drift along, their movement changes the distribution of their electricity incessantly, causing thousands of short-range static impulses.

\* Member, American Meteorological Society.

lieved that this normal potential is changed to any extent by changes in the weather or storms. This electrical potential gradient above the surface of the earth does not, so far as investigation can disclose, cause the stray or foreign static effects. Just what part it takes in radio activities is not known and, for the present, we might as well leave it out of this discussion. Static seems to be entirely free from atmospheric electricity, and of a different kind.

COMPOSITION OF THE ATMOSPHERE

The earth is surrounded by two great belts of atmospheric distribution. The lower one is known to meteorologists as the *troposphere*. The outer one is called the *stratosphere*. Between the two there is a region known as the *tropopause*. (See Fig. 1.) For instance, a study of recorded temperatures during an ascent throughout the two regions shows definitely that the temperature falls off rather sharply as the distance from the surface of the earth increases toward the tropopause. From that region temperatures remain constant and even are known to increase slightly out into space.

It is in the lower belt, the troposphere, that our familiar changes in the weather occur. It is believed that this region is the breeding place of atmospheric static and that little or none originates above the tropopause. This latter region, and the belt immediately above, the stratosphere, while not breeding static, affect transmission by the development of much ionization by day beneath the outer boundary, the Kennelly-Heaviside Layer.

Static is not evenly distributed over the surface of the earth. At times it may cover a relatively small area, while a nearby region may be quite free from its interference. The tropics abound with static, while the polar regions probably never experience static as we know it. During summer static is much stronger and more persistent than in winter.

If we now reconsider the tropopause region, we find that in summer it will rise to higher elevations than in winter, that over the tropics it is always higher than

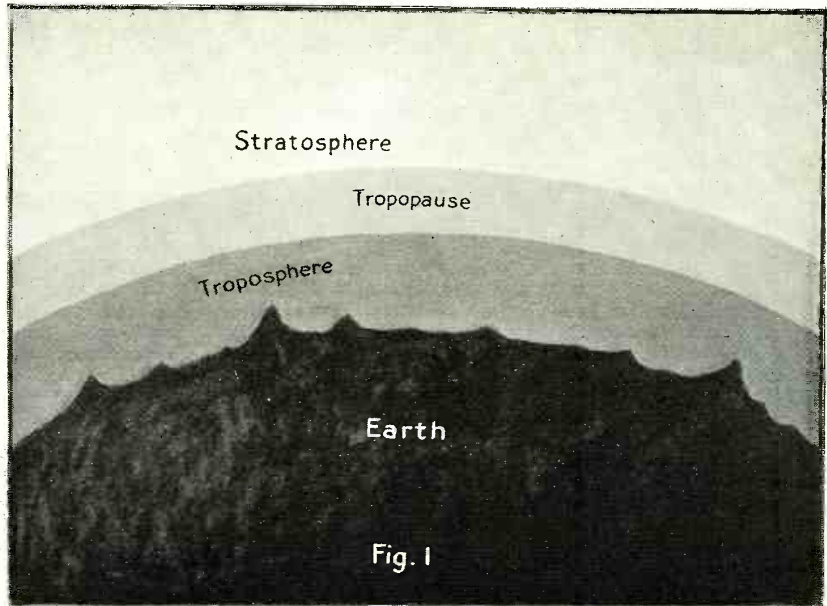

Fig. 1  
The stratosphere is a region above the weather; it does not change in temperature, but its radio "ceiling," the Heaviside Layer, moves up and down under the electrical influence of the sun's rays.

over the polar or temperate regions, and that passing storms, cold waves, and other weather changes cause it to fluctuate in elevation. When the tropopause is relatively higher it means that the depth of the troposphere is greater and more static-producing atmosphere is present; and when the tropopause is lower, there is less static bearing area beneath.

Some believe that considerable static is produced through conflicting and neutralizing earth-currents due to irregularities in the flow of normal atmospheric electricity to different portions of the earth, or due to uneven distribution of the replenishment of ions to the air from the earth. While it is quite plausible that some earth currents will flow in sudden pulsations up the grounding wires into the radio sets, such is

not the rule; rather, it is the exception. The fact that underground antennas eliminate static pulsations to a great extent shows the fallacy of this line of reasoning. On the other hand, aviators and balloonists carrying radio sets while on flights have experienced intense static reception while in the clouds, and often when in clear sky. In fact, aerial receivers, while many hundreds or thousands of feet above the earth's surface, have become so charged with electricity that the antennas had to be disconnected, an operation accompanied by severe sparking and shocks to the aeronauts. It is, therefore, perfectly reasonable to believe that practically all known static is of atmospheric origin.

No one has been able to determine how atmospheric static is actually produced, except to state that certain meteorological events cause intense ionization in the atmosphere. If there is any static produced by causes other than weather, those causes have not been fully determined. Of course, this is exclusive of "static" produced by modern electrical and mechanical apparatus.

IONIZATION OF THE AIR

We know that the atmosphere is constantly in a state of agitation. There are warm and cold winds, ascending and descending air currents, dry and humid regions of atmosphere, and underlying land and water areas that influence the condition of the air above. These conditions affect the ionization of the atmosphere. Whenever the moisture-content of the air is great, or when dust is excessive, ionization may be quite heavy; since ionization depends upon the presence of electrically-charged atoms and electrons and ions in the atmosphere. The natural gases of the atmosphere may become ionized, but when additional matter is present, in the form of much water vapor or dust, the ionization is much denser.

Atmospheric ionization is believed to be caused by impact and friction between atoms and electrons, the electrical charging of the small globules of moisture deposited upon minute dust particles, and the break-

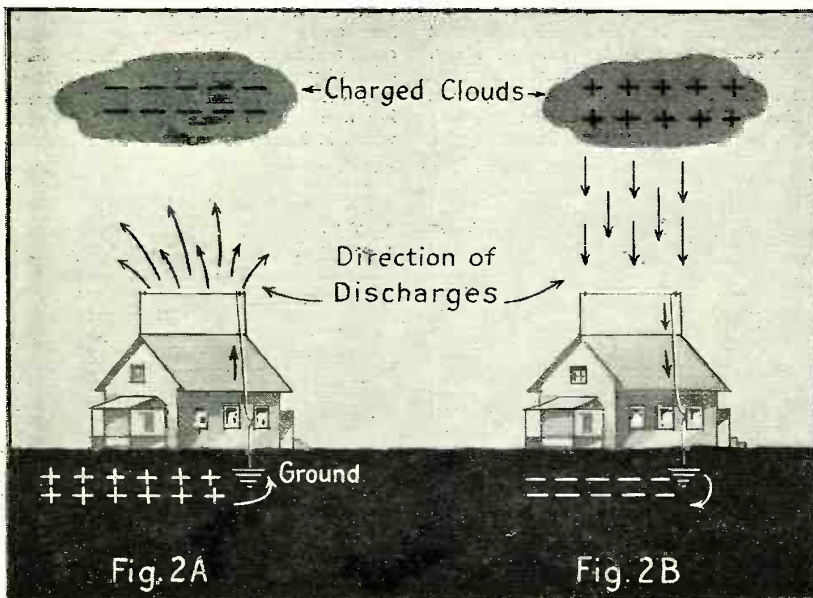

Fig. 2A  
Fig. 2B  
We may consider electricity as flowing from the ground to the clouds, attracted by the charge above, as well as in the opposite direction. A very slight discharge of electricity from the aerial into the atmosphere may cause a terrific noise in the speaker.

ing of raindrops, snowflakes or ice particles. Falling rain may produce great ionization due to the impact between drops, and their constant breaking and recombining. The drops themselves bring down to earth considerable *positive* electricity; while the fine spray from breaking drops, when thrown off into the atmosphere, gives a negative ionization.

From this we see that the atmosphere becomes filled with many millions of small patches or areas of atmospheric gas which is ionized to some degree. Each area, therefore, has its individual electric charge. This charge is sufficient, when it comes into contact with an antenna, to discharge through the radio set with a loud static crash. Even a discharge in the air between oppositely-charged areas at some little distance away will set up a minute electromagnetic wave that will be heard by all sensitive receivers within range. In severe conditions, when the atmosphere is very highly charged, perhaps a thousand or more drifting areas of charged atmospheric gas might drift past an antenna within a minute, each giving off its excessive electricity in the form of a static discharge.

#### STORMS

When this charged atmospheric condition becomes greatly excessive a thunderstorm will develop. Whenever we have a hot and humid ascending air current which comes into contact with low-running cooler air currents from above, dense clouds are built up as this rising air condenses into heavy, dark and wet fog. When there is violent cloud activity the electrical ionization is heavy, and soon the clouds become charged with a potential of millions of volts. When this potential between clouds having opposite charges, or the clouds and the earth beneath, becomes too great, the strain and stresses in the intervening air space cause a breakdown in the natural insulation and a lightning flash occurs. Powerful electromagnetic waves are sent out for great distances, and affect all radio receivers within the area.

The electrical discharges in a thunderstorm are many and varied. Some are very short and occur between fragmentary portions of one cloud, others between the earth and clouds, and still others between clouds entirely separated. Some lightning flashes are often more than a mile in length. It has been believed that a lightning flash is oscillatory in action, and perhaps some actually are; but recent discoveries have given good indications that it is a one-way current flow creating an electrical surge rather than an oscillation. In any case, whether oscillatory or surging, the current has its powerful electrical field which induces current surges with a static crash in all radio receivers within range.

When we consider the vast amount of electrical energy liberated by a lightning flash, and that it has been estimated that about 1,500 flashes are occurring each minute throughout the world, it is no small wonder that a little static may be heard in sensitive receivers at nearly any time. Some parts of the country have more thunderstorms than in other parts; Florida experiencing the most and the coast of California the least. Thunderstorms are practically unknown in northern latitudes, but are of common occurrence in the tropics and in the summer in high mountain regions. Thunder, which is the sound of air expansion due to the heat liberated by the lightning

flash, travels as a sound wave, while the lightning flash travels as a light and electrical wave. One may see a lightning flash and hear it as static simultaneously, while the thunder will be heard many seconds later.

#### TYPES OF STATIC

When a charged cloud or other area is passing overhead it attracts or induces an opposite charge in the ground area beneath. As the attracted charge flows along the earth's surface at the same rate as the cloud's travel, some of it flows up the ground wires of radio receivers and discharges into the air through the antennas. (See Fig. 2A.) These momentary surges of the earth charge give rise to severe static crashes in the receiver. Induced currents in the antenna also produce similar symptoms as they flow down into the earth. (See Fig. 2B).

Static noises have been classified into a few different types, such as "grinders," "clicks," "hisses," etc. It is obvious that each classification is produced by an entirely different source. The static crash of lightning is different in sound from the little clicks and hisses caused by patches or areas of drifting electrified atmospheric gas, such as may be noticed on clear, hot and dry days in summer.

Intense static may be produced by hot dry winds, such as are experienced over some of the Middle Western states. These winds carry a great deal of dust and there are cases on record when the air has been so highly charged that ignition systems of automobiles have been seriously interfered with; and fences, windmills and other metal objects have become charged to such a high potential that severe shocks were experienced by those touching the objects. During such occasions radio sets produced a constant static roar and much greater interference than during a thunderstorm.

The fact that atmospheric static is produced while the air is undergoing changes that precede and accompany rainy or generally bad weather has been used as a

method of forecasting weather. When a night of static freedom is followed immediately by increasing static noises it is safe to assume that a change to unsettled or bad weather will result within twelve hours or more. With the use of a directional loop antenna, an expert might be able to locate approaching storm centers a day or so in advance with some fair degree of reliability. However, this is merely an experimental matter which cannot be relied upon as accurate.

#### WHAT IS FADING?

Signal fading, that peculiar phenomenon which causes radio signals to rise and fall in intensity, at times with remarkable regularity, but mostly with an uncertain and irregular periodicity, seems to be not of meteorological origin. Without doubt, fading eventually will be found to be directly related to changing conditions in the conductivity of the total atmosphere, especially the outer ionized portion of the stratosphere, variations in the height or level of the Heaviside Layer, or perhaps to some extent in counter earth-currents which may affect the uniformity of the transmitted earth wave to some slight degree.

However, it is likely that a certain amount of fading is due to atmospheric conditions. This is an assumption only, although years of meteorological and radio correlations seem to indicate that such may be the case. It appears that this form of fading results from large movements of ionized atmosphere drifting past transmitting or receiving stations, mostly the former. It is quite likely that the conductivity of the mass of ionized air is of sufficient importance to affect the transmission of the electromagnetic waves being broadcast out from the antenna of the transmitting station directly below. The action is that of an absorbing and deflecting blanket spread over the transmitter, which effectively prevents all of the power of the emitted wave from passing on and up toward the Heaviside Layer. (See Fig. 3.) Thus, the variations

(Continued on page 177)

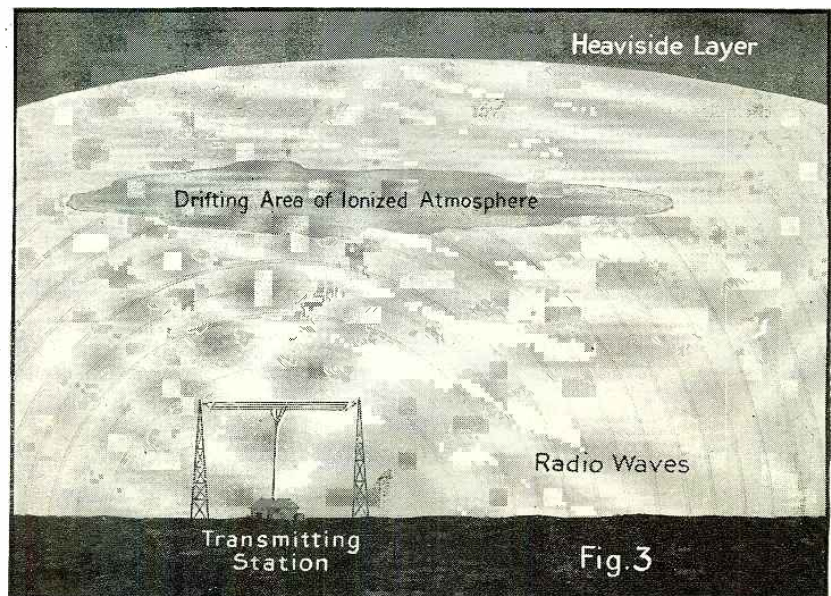

The natural boundary of the waves is the Heaviside Layer, but they may be stopped or turned aside by electrified masses of air, very much lower.

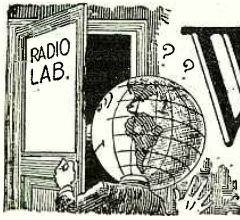

# What's New in Radio



## New Short-Wave Coils Fit Into Standard Tube Socket

A receiver kit, consisting of four short-wave coils wound on plug-in type forms which fit into a standard UX-type tube socket, has recently been placed on the market to satisfy the increasing demand for short-wave receiving apparatus. The same manufacturer has also developed an R.F. choke coil for use in short-wave receivers. A booklet which contains complete directions for building a short-wave receiver and a short-wave converter unit for a broadcast receiver is supplied with the parts.

The set of four short-wave coils and the short-wave R.F. choke coil (A) will be found pictured on this page. Each coil has two windings, grid and tickler. When employed in the manner recommended by the manufacturer the set of coils will cover the wave band of 16 to 210 meters.

The molded bakelite forms on which the coils are wound are  $2\frac{1}{8}$  inches long by  $1\frac{3}{16}$  inches in diameter. Each form is of

used on all the tickler windings and colored silk-covered "Litzendraht" wire on the grid windings of the two small coils. Solid wire is used on the grid windings of the two larger coils. The coil form is so wired that the grid and F minus terminals of the tube socket provide the connections for the grid coil and the plate and F plus posts of the socket the tickler connections.

*Manufacturer: Dresner Radio Manufacturing Corp., New York.*

*This hand microphone (right) has been designed for use with receivers using A.C. tubes. It is provided with a cord and UY-type plug for insertion in the detector socket.*

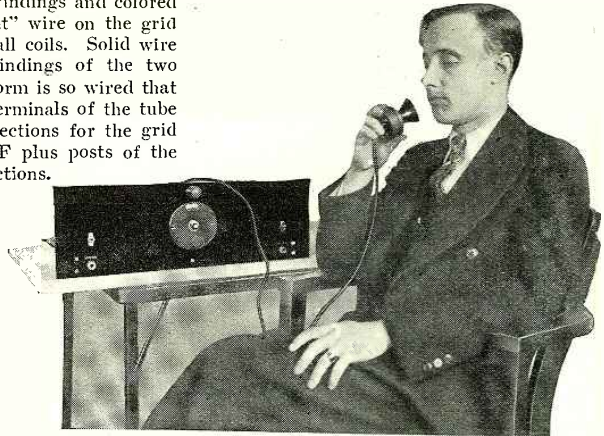

## Hand Microphone Has 5-Prong Plug for A. C. Sets

A hand microphone, which, when connected with a radio receiver, makes it possible to announce through the loud speaker, provides a constant source of amusement in the home. In addition, it may be employed for many useful purposes. These microphones usually are provided with a tube-base plug, and are connected with the receiver by removing the socket of the detector tube and inserting the tube-base plug in its place. The wire from the microphone to the set may be as long as desired, so it is possible to talk in any part of the house and have the voice reproduced by the loud speaker, wherever the latter is located. The audio amplifier of the receiver amplifies the voice currents developed by the microphone, and as much volume is obtained from the loud speaker as with radio signals. The microphone is an "electromagnetic" device, and is operated without a battery of any kind.

It is not difficult to think of a number of ways in which the microphone may be used for both practical and amusement purposes. It is ideal for inter-room communication, both in the home and in an office, as it avoids the necessity of calling. When the instrument is being used to amuse guests the announcer and the microphone should

be concealed in another room; then the hidden person may insert humorous passages in a radio program or make comments on his friends in the other room. The stunt is sure to mystify everyone.

Most of the microphones now on the market are equipped with a standard UX-type tube-base plug and they may be used with any battery-operated receiver. However, because of the increasing popularity of the A.C. electric receiver, a demand for a microphone with a UY-type five-prong plug now exists. The microphone illustrated above is made in this manner.

A special feature of this A.C. type microphone is that, after the plug has been inserted in the detector socket of the receiver, the detector tube may be inserted in the top of the plug. This arrangement avoids the necessity of incapacitating the radio receiver during the time the microphone is connected. Also, it makes it possible to leave the microphone connected at all times. The microphone is provided with a small push switch mounted on the case; when the instrument is in use it is necessary to hold a finger on this button. With the switch in its normal position the microphone is disconnected and the radio set operates in the usual way.

*Manufacturer: Brooklyn Metal Stamping Company, New York.*

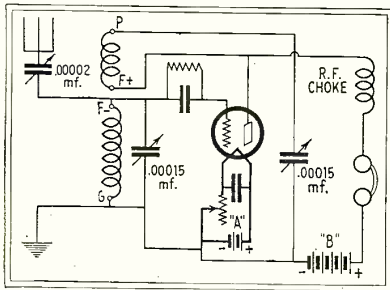

*Detector-circuit diagram of standard short-wave receiver using tube-base plug-in coils.*

a different colored bakelite, in order to permit easy identification. When used in a circuit employing two .00015-mf. variable condensers (one in shunt with the grid coil and the other in series with the tickler) the black coil will tune from 16 to 32 meters, the brown coil will tune from 29 to 58 meters, the blue coil will tune from 54 to 110 meters and the red coil will tune from 103 to 210 meters. The coils are of low-loss construction, the turns of the windings being spaced. Enamelled copper wire is

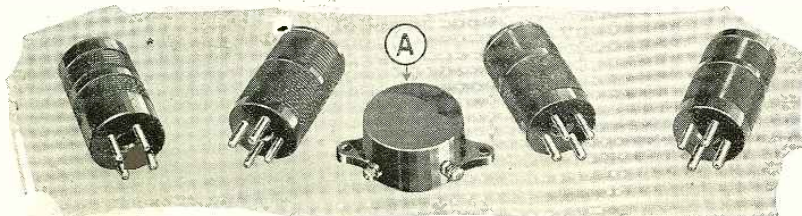

*These four tube-base plug-in coils make possible operation on four different short-wave bands and enable continuous reception between 16 and 210 meters. A is an R.F. choke coil designed for use in short-wave receiving sets.*

## New A. C. Screen-Grid Tube Has 15-volt Filament

FANS who are interested in both A.C. operation and screen-grid amplification will be gratified to learn of the development of a new screen-grid tube which may be operated from an A.C. supply. This tube is of the heated-cathode type, but otherwise has characteristics similar to the standard 222 type. It is equipped with a standard UX base, the cathode being connected to one terminal of the heater, which is a thin carbon filament.

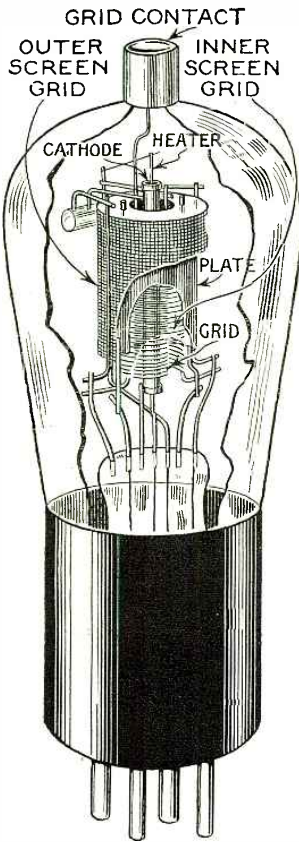

This A.C. screen-grid tube differs from the battery type only in the construction of the filament and of the outer grid, which is a mesh of wire instead of a spiral coil.

The essential electrical characteristics of the tube follow:

- Amplification constant, 400 ("mu").
- Mutual conductance, 445 micromhos.
- Plate-to-control-grid capacity, .04 mmf.
- Filament potential, 15 volts.
- Heater current, 0.35 ampere.
- Plate potential, 135 volts.
- Screen-grid potential, 30 volts.
- Control-grid bias, 1 volt.
- Plate impedance, 900,000 ohms.

From the above it will be seen that the filament requires a potential of 15 volts A.C. This voltage may be obtained easily from a standard step-down transformer of the type used for the operation of toy electric trains.

The accompanying cutaway view shows the mechanical construction of the new tube; this, it will be noticed, is very similar to the D.C. type, but two important changes have been made. First, the filament construction had to be changed in order to permit the use of a carbon heater and cathode; and second, a wire mesh has been substituted for the spiral coil used as the outside section of the screen grid. The terminals of the new tube are arranged in exactly the same order as those of the D.C. type, and the cathode is connected to the "A+" terminal, thereby eliminating the necessity of a UY-type (five-prong) base.

Manufacturer: *Arcturus Radio Company, Newark, N. J.*

This diagram shows the circuit which is used in connection with the special screen-grid tuning unit described on this page.

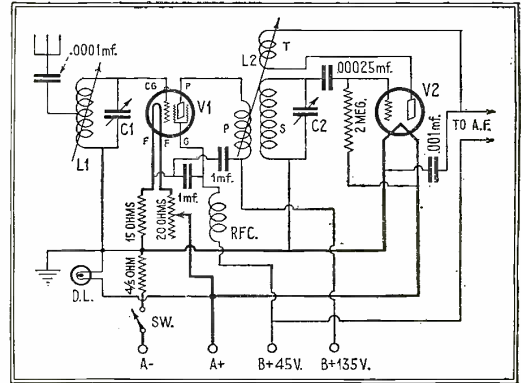

### New Dials Accompany 222-Type R. F. Unit

A NEW R.F. tuning unit designed especially for use with the 222-type screen-grid tube, and two new dials for use with standard variable condensers, have been brought out by a New England manufacturer. These items are pictured on this page.

The tuning unit will appeal to the home radio builder because of its neat construction and of the ease with which it may be built into a complete receiver. It consists of two variable condensers (C1, C2), mounted on a long, rigid metal frame, which also supports, at its left and right ends, respectively, an antenna coupler (L1) and an interstage transformer (L2). The two condensers are operated as one by an illuminated drum dial, the position of which may be observed in the accompanying illustration.

The unit fits on a regular 7 x 18-inch panel, in which only seven holes need be drilled. Additional support for the framework must be provided by a sub-panel, on which the tube sockets and other components necessary for a complete receiver may be conveniently placed.

The antenna tuning coil L1 is in reality

necessity for an external "trimmer" condenser to keep the grid circuit of the screen-grid tube (V1 in the diagram) sharply in tune with the grid circuit of the detector tube (V2).

The knob T on the end of coil L2 controls a tickler coil which turns inside the extreme right end of the fixed (secondary) winding. This tickler provides the means whereby regeneration is obtained in the detector circuit.

The circuit for which this tuning unit is intended is very similar to the hook-up most commonly known as the Browning-Drake, which comprises one stage of tuned radio-frequency amplification with a regenerative detector. However, it is designed to take advantage of the superior R.F. amplifying characteristics of the screen-grid tube, which is used in the position indicated at V1 in the accompanying wiring diagram. Stable operation of the receiver, without trouble due to oscillation, is readily obtainable without recourse to neutralizing methods or the use of shields. Although shielding of screen-grid tubes is held to be imperative for best operation, the usual aluminum or copper cans may be dispensed with in receivers incorporating this tuner, because of the simplicity of the hook-up.

The accompanying diagram shows the detailed connections of the circuit recon-

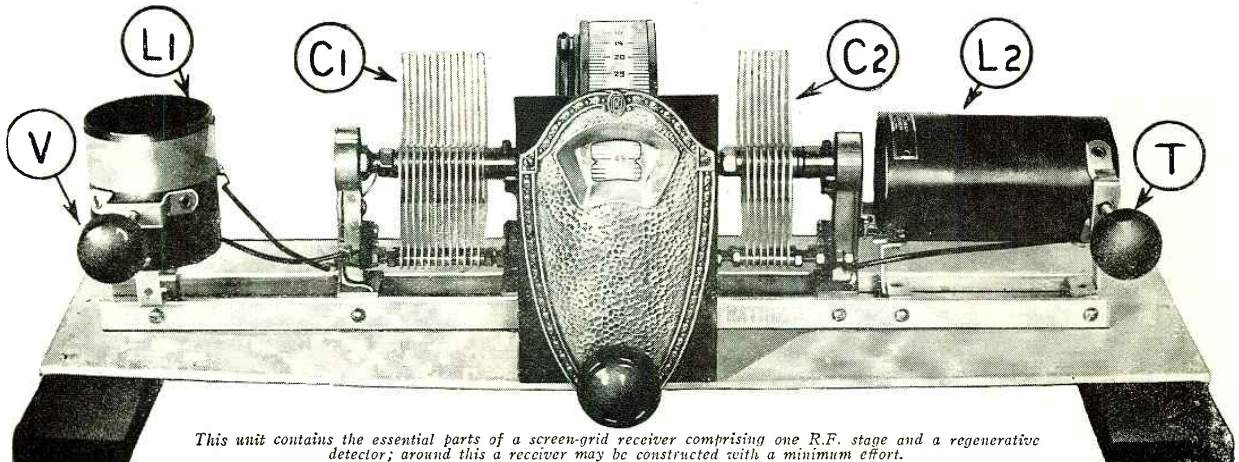

This unit contains the essential parts of a screen-grid receiver comprising one R.F. stage and a regenerative detector; around this a receiver may be constructed with a minimum effort.

mended for the tuning unit. The aerial is coupled to the grid coil L1 through a fixed condenser of .0001-mf. capacity. The plate of the screen-grid tube runs directly through the primary P of coil L2, the battery circuit being shunted by a heavy by-pass condenser (1-mf.). The screen element of the tube (to which connection is made via the "G" post on the tube socket) runs to the "B" battery through a radio-frequency choke, RFC. Another heavy by-pass condenser is used in this portion of the set. The purpose of the by-passes and the choke is to keep radio-frequency energy out of the battery circuit, which, being common to both amplifier and detector tubes and to the plate and screen elements of the screen-grid tube alone, might cause considerable oscillation troubles.

The detector portion of the set is of standard design. The leads marked "to A. F." may be continued to any audio amplifier of the usual models.

The two new dials have silvered panel plates of identical appearance; but one model is of the "drum" type, while the other is of the straight-mounting variety. They are of sturdy construction, and turn without backlash. They may be used with practically any variable condensers.

Manufacturer: The National Co., Inc., Malden, Mass.

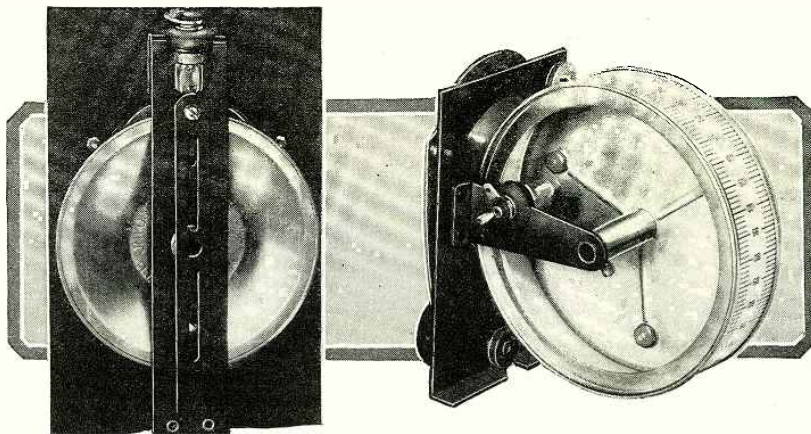

Except for scale markings, these two dials are identical when viewed from the front. The dial on the left is for condensers with shafts at right angles, to the panel, and the drum dial for those parallel to it. A front view of the dial is shown in the picture of the tuner on page 123.

ceptacle and the transformer. Therefore, with this arrangement it is necessary only to plug the "B" power unit into the receptacle, in order to have it controlled by the switch which governs the filament transformer.

The transformer has been designed to provide ample filament current for the aver-

### Scanning Disc Made for Television

FOR both the reception and transmission of television, "scanning discs" are required. Such discs are usually of metal, and are drilled with a number of holes located in a spiral path near the outer edge. In both transmitting and receiving the discs are rotated at the same definite rate of speed. In the transmitter, one such disc is placed between the object and the photoelectric cell; and in the receiver it is placed between the spectator and the neon tube.

It is the object of the discs to analyze and reconstruct the images which are televised; and, unless the discs of the transmitter and receiver correspond exactly in every way, including speed of rotation, television is impossible. Many experimenters have endeavored to construct their television discs, but have found it very difficult to obtain satisfactory results. Every hole must be of just the required diameter and in exactly the proper position, and it is difficult to accomplish this with the necessary precision with ordinary tools.

The television disc pictured on this page has just been placed on the market to aid experimenters in their work. It is available in several sizes for the different systems of television which will soon be regularly broadcast. The arrangement shown is for receiving the pictures which are being

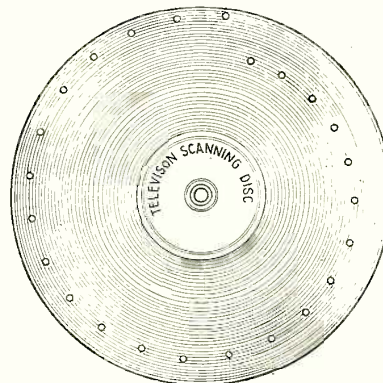

These television scanning discs have been designed to receive the broadcasts from WGY and WRNY. They are 12 and 18 inches in diameter, and have 24 and 36 holes, respectively.

### Filament Transformer For A. C. Sets

THE filament-heating transformer pictured on this page has been designed to facilitate the construction of electric radio receivers using A.C. tubes. It will simplify the wiring of any radio installation in which it is used, regardless of whether the receiver is a new model or a battery-operated set which has been converted for A.C. operation. The new features of the transformer are the wires which have been provided for connecting an external switch, and the 110-volt receptacle mounted on the case for plugging in the "B" socket-power unit. These make it possible to turn on the receiver at one switch without the necessity of a complicated circuit arrangement.

The wiring of the transformer is shown in an accompanying diagram; it will be noticed that its primary winding and the receptacle for the "B" power unit are connected in parallel, and the wires for the power switch are so arranged that they control the power going to both the re-

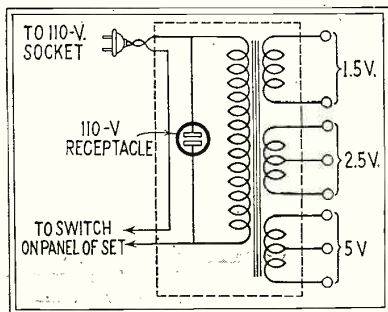

The internal connections of the new filament-heating transformer described herewith.

age receiver employing a combination of 226-, 227- and 171-type tubes, and it may be used for operating as many as seven. The 1½-volt winding for the 226-type tubes is capable of delivering a current of 4.2 amperes, which is sufficient for heating four tubes; the 2½-volt winding has a maximum output of 1.75 amperes and will provide current for one 227-type tube; and the 5-volt winding with an available supply of 0.5 ampere provides current for two 171A-type tubes.

The picture shows the external appearance of the transformer, which is housed in a compact metal case measuring 3 by 3 by 5¼ inches. The wire with plug (P) attached for connection to the 110-volt socket, the wires (SW) for the power switch and the receptacle (R) for the "B" power unit are mounted on one end. At the other end, the eight binding posts for the filament voltages are mounted on a bakelite panel. Two binding posts are sufficient for the 1½-volt winding, and three each are required for the 2½- and 5-volt windings, which are provided with center-tap connections. The transformer is mounted on small metal feet which have been drilled to facilitate mounting.

Manufacturer: Dongan Electric Mfg. Co., Detroit, Mich.

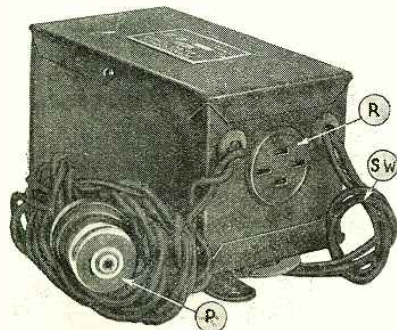

In this filament-heating transformer provision has been made for connecting a switch to control the operation of the entire receiver. SW, wires for switch; R, receptacle for "B" power unit; P, plug for light socket.

broadcast by station WGY. It is 12 inches in diameter and has 24 holes; and is designed for use in reproducing a picture 1.5 inches square. An 18-inch disc with 36 holes is designed for WRNY television broadcasts. At this writing (a month before publication) experimental tests are still being made with this novel development.

Manufacturer: Daven Radio Corporation, Newark, N. J.

### Large Neon Tube Now Made for Television

**A**MATEURS who are experimenting with radio television apparatus have found that their circuits require a larger neon (glow) lamp than is generally available

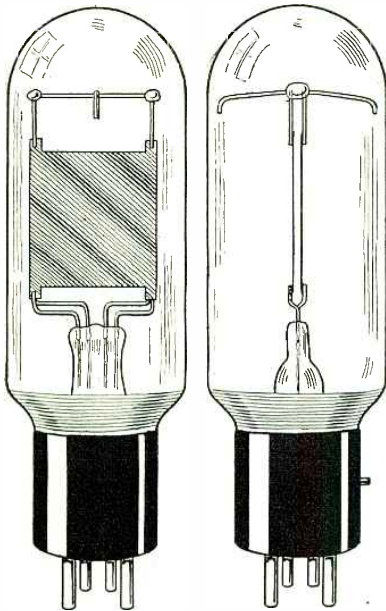

Two views of new neon tube, showing construction of parallel plates. These tubes are used in television receiving circuits.

today. In answer to this demand, the tube shown in the above illustration has been placed on the market. This tube is much larger in size, and will pass approximately twice as much current as the tubes previously used.

In order to receive television pictures, there is required a source of light which is capable of changing its intensity almost instantly. This light reproduces the picture which is being transmitted, and its position in the circuit is comparable to that of a loud speaker in a broadcast receiver.

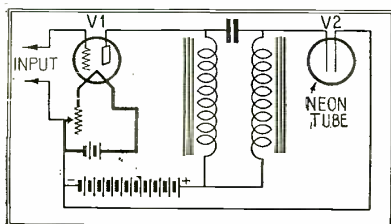

The circuit customarily used when connecting a neon tube to the output of a vacuum-tube amplifier.

In fact, if a lamp of the type used for this purpose were connected to the loud-speaker binding posts of a broadcast receiver, it would convert the electrical energy into light vibrations instead of sound vibrations. It may be seen, therefore, that the familiar type of heated-filament (incandescent) lamp would be entirely unsatisfactory, as a change in the intensity of its light requires too great a length of time for the instantaneous impulses of television.

A gas-discharge tube of the neon type provides the only known, practical, solution to the problem of obtaining sufficiently rapid light variations. The tube is of very simple construction, as may be seen from the illustration. It consists of two large plate elements, parallel to each other and separated a fraction of an inch. The tube is filled with neon gas, and is mounted on a standard UX-type base. The circuits in which it is used are very simple; a diagram on this page shows one of the possible arrangements. V1 is the last-stage amplifier and V2 is the neon tube. The "B" battery which supplies plate current for the amplifier tube also provides the necessary potential for the neon tube.

According to the manufacturer's specifications, the tube has a dynamic resistance of 1,200 ohms. The current passed through the tube should never exceed 20 milliamperes D.C., which corresponds roughly to a terminal potential of 200 volts D.C. In operation, either terminal may be connected to the negative terminal of the battery. However, when the tube is operated with D.C., a current-limiting resistor should be connected in series with the circuit at all times, in order to prevent overloading.

Manufacturer: Raytheon Manufacturing Co., Cambridge, Mass.

method of modernization which may be applied to his circuit.

Recently, a number of R.F. booster units have been placed on the market, to satisfy the demand for a device which will bring up-to-date these old receivers. These units, usually, are designed for use ahead of the R.F. amplifier of the receiver and, when connected in this manner, they provide the advantage of an additional stage of R.F. amplification. A booster unit uses one tube and adds an extra tuning control to the receiver. It may be operated from the same batteries or socket-power units which are used for the receiver.

Two pictures, and a diagram on page 170, give details of a R.F. booster unit of recent design. This device employs one of the new 222-type screen-grid tubes which provide an enormous amplification when used in R.F. circuits. As a result, when a booster unit of this type is connected ahead of a receiver, the effect is greater than it would be possible to obtain with an additional R.F. stage of standard design. The device when properly operated will increase the sensitivity, selectivity and volume of the receiver, or in other words, provide the extra "pep" which is needed. Also, the booster unit permits more satisfactory reception during summer static by making possible the use of a shorter aerial.

The wiring diagram shows the exact circuit of the booster unit; the grid circuit of the tube is directly coupled to the aerial circuit, and a variable condenser (C1) connected in shunt with a coil (L1) is the tuning control. Two binding posts are provided for aerials of different length; post S provides maximum coupling for a short aerial, and post L gives greatly reduced coupling for a long one. Inductive-capacitive coupling is employed to connect the plate circuit of the booster with the receiver; the R.F. choke coil (L2) and (Cont. on page 170)

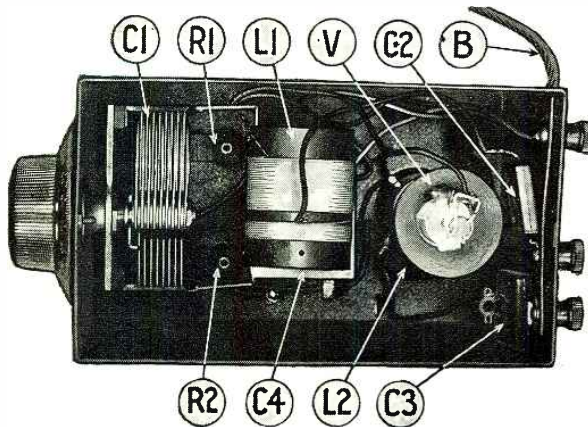

Left, the screen-grid R.F. booster unit with the cover of its shield removed. Below, appearance of booster in metal case. B is the battery cable, and the other symbols correspond to similarly-designated parts in the text and diagram.

### Screen-Grid Booster Unit Improves Receiver

**T**HERE are thousands of old-style receivers in operation today which fall just short of the mark set by the modern broadcast listener for satisfactory reception under present conditions. In a majority of cases one of three complaints is made; the set lacks sufficient volume, it is not sensitive enough to receive distant stations, or it does not provide the selectivity required to separate local stations. Usually, the owner hesitates about discarding the receiver, as the results are otherwise quite satisfactory; and he is looking constantly for some

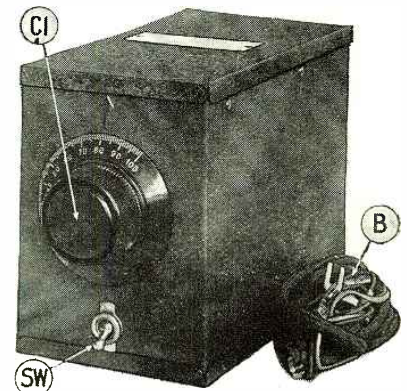

# Some Odd Uses for Vacuum Tubes

Their Best-Known Work is in the Parlor Radio Set; but Science and Industry Find Many Unusual, though Valuable, Applications for Them

By J. E. Smith\*

MANY are the eulogies that have been sung about the wonderful vacuum tube that we all use in our radio receivers; many, many times has its great versatility been spoken of. But unless you happen to be making radio your business, it is improbable that you will get to know at first hand any of the thousand uses to which a tube may be put, excepting its applications in your radio receiver.

It is the purpose of this article to acquaint you, more or less, with a few of the uses of vacuum tubes. We cannot hope to include all of the uses, for there are far too many of them for the space available in this magazine. There are many more, perhaps, than you imagine. Just think, in your radio set alone, there may be as many as six different applications of the vacuum tube. You are acquainted with these applications, so we will take time only to mention them.

First, we have the *radio-frequency amplifier* tubes, which amplify the radio-frequency impulses which the antenna collects. Next, we have the *detector* tube, which so changes the form of these radio-frequency impulses that they now become audible, or capable of being heard, providing they are strong enough. If these are not sufficiently powerful to operate the loud speaker they are amplified by the *audio-frequency amplifier* tubes. It often happens, however, that the ordinary audio-frequency amplifier tubes become overloaded; that is, they are called upon to do more work than they are designed for. Therefore, in many receivers there is employed a more powerful tube, which is called a *power amplifier*.

## AUXILIARY TUBES

Next, we may look into our power-supply apparatus, if we have a set that operates from house current. First, there is required a *rectifier* tube, which so alters the *alternating* current supplied by your electric company that *direct* or constant current becomes available for operating the plate circuits of the tubes. But it often happens that the voltage supply in your house is not very constant; sometimes the voltage is high and sometimes it is low, so that the voltage applied to your radio receiver may vary considerably. In order to correct this difficulty, which will cause poor operation of the set when the variations are great enough, there may be used in your power supply what is known as a *regulator tube*. If the power supply is constant enough, this regulator tube is not necessary, although it is often used.

These are the six main types of tubes used in radio receivers, but there are many variations of them. For instance, there are tubes operated by direct current, tubes operated by alternating current, gaseous tubes, tubes having very high vacua, two-electrode tubes, three-electrode tubes, half-wave rectifiers, full-wave rectifiers, and so on. These things are much written about in the press, so we will not discuss them here; you have no doubt read much about them in RADIO NEWS from time to time. From now on this article will be devoted to some interesting but not well known applications of the vacuum tube.

## TUBES AS MEASURING DEVICES

The applications of the radio tubes to

electrical measurements are very numerous. Many radio fans know something or other about the way in which the vacuum tube is used as a voltmeter or as an ammeter. Fig. 1 illustrates the use of the vacuum tube as a voltmeter. Suppose we have a generator supplying current to a load of some kind; we can connect an ordinary vacuum tube across the terminals of this load, as at

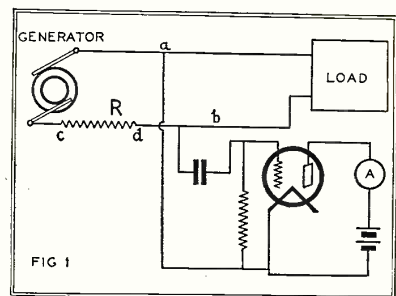

The vacuum-tube voltmeter is a device employing an ordinary tube. It affords a very exact comparison of voltages in the range of its "characteristics."

*ab*, and a current-indicating device A (such as a milliammeter) will tell us how much current is flowing in the plate circuit of this tube. Then all we have to do is to disconnect the tube from the load, and connect it to some other source of voltage which we can control. By varying this until we obtain the same current indication at A, we know the second voltage to be equal to the former, or line-voltage. In other words, the line-voltage produces a certain effect on the tube, causing a certain plate current to flow. Any other source of potential that produces the same plate current must have the same voltage as the line.

Next, suppose we want to find the *current* flowing in the main line. We could insert a resistance R, or use any resistance which may happen to be in the line already, whose value we know, and connect the vacuum tube across its terminal, as at *cd*, Fig. 1. The voltage across this resistance is measured by the same method used to measure the voltage across *ab*. Then, knowing the voltage drop in the resistance, and the value of the resistance, the current flowing through the latter is obtained by simply dividing the voltage by the resistance.

There is an interesting application of this method to the measurement of very high voltages, such as we have in power packs. The tube as used in Fig. 1 amplifies, and is well adapted to the measurement of small voltages. The higher this voltage the higher will be the reading of the milliammeter A. Very high voltages, for instance, say 500 volts, would cause the tube to be saturated, or considerably overloaded. For this reason, we must use special tubes for measuring high voltages, or else find some special way in which to use the ordinary tubes.

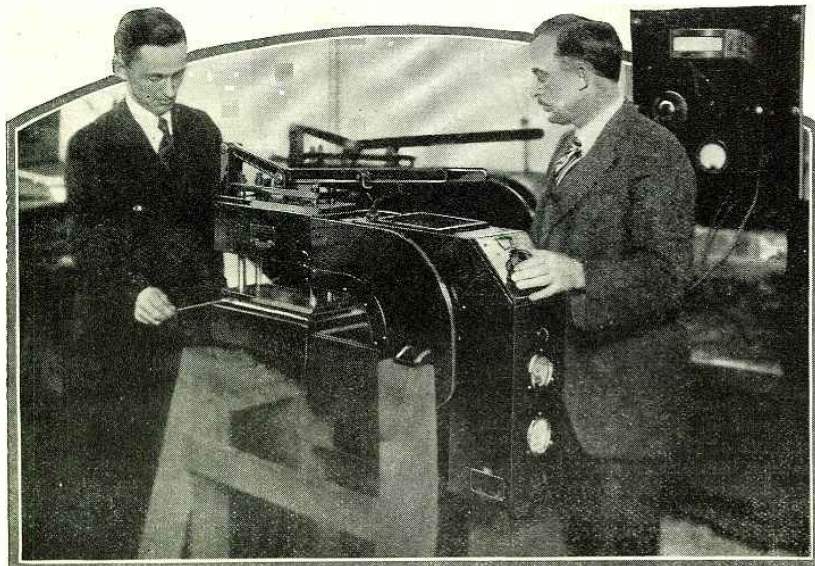

The Verigraph, a device which determines the thickness of a continuous sheet of material as it is being made. The capacity caused by the dielectric web is recorded continuously through its effect on a vacuum-tube circuit. Left, A. Allen, one of the designers; right, W. A. Ready.

\* President, National Radio Institute



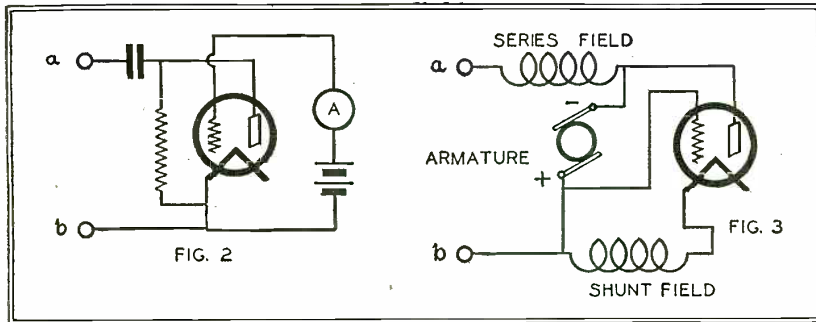

In Fig. 2 an ordinary tube is "hooked up backwards to measure higher voltages. In Fig. 3 we have a circuit employing a special tube to regulate a dynamo's output voltage.

**WORKING BACKWARD**

Fig. 2 illustrates one of these special applications of the ordinary tube. The tube is so connected that it does not amplify, but rather de-amplifies, so to speak. The tube circuit is inverted, the plate being used for the grid, and the grid for the plate. To explain: suppose the tube which we are considering has an amplification factor of seven; this means that one volt applied to the grid in Fig. 1 will have the same effect as a voltage of seven applied directly in the plate circuit of that tube. In the case of Fig. 2, however, a voltage of seven applied to the plate will have only the same effect as one volt applied directly in the grid circuit.

The current in the circuit of Fig. 2 also varies differently. In Fig. 1, we have said that increasing the voltage at *ab* causes the plate current in A to increase. Contrariwise, in Fig. 2, an increase of voltage at *ab* causes the "plate" current in A to decrease. This does not cause any difficulty, however, for we do not care much what value the "B" current may happen to have; all that we want to know is its value, so that we can duplicate it when applying our known voltage in order to find our unknown quantity.

**A REGULATOR TUBE**

A specially-designed vacuum tube, one designed to carry more plate current than our tubes, has been used to regulate the voltage of direct-current generators. Such an application is pictured schematically in Fig. 3. Here we have represented a compound-wound, direct-current generator. The shunt field has in series with it the plate circuit of the vacuum tube, and the input circuit of the tube (that is, the grid and filament) is connected to the armature of the generator, as shown.

Now suppose, for some reason or other, the engine driving the generator should increase its speed momentarily or, perhaps, if our generator is being driven by a motor which is operated on power supplied by the electric company and the line-voltage should drop, the speed of the driving motor would decrease. At the same time, the generator speed would decrease and the generated voltage would become less. This means, then, that the negative voltage applied to the grid of the tube would become less, and consequently the resistance in the tube between the plate and filament would decrease, thereby allowing more current to flow through the shunt field winding.

This increase of field current would increase the generated voltage, and if the circuits are arranged properly, it is possible to

make the increases pretty nearly equal the decreases; so that we should have very constant voltage supplied at the terminals of the generator, as at *ab*, in Fig. 3. Such an arrangement is made possible by the fact that shunt field windings of such machines

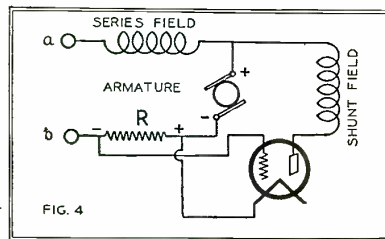

If we require from a generator a constant current, instead of a constant voltage, as in Fig. 3, we may utilize the circuit shown above.

have rather high resistance in comparison with the field windings, and consequently carry a fairly low current, which is within the range of the operating plate current of the tube.

Another and somewhat similar arrangement is shown in Fig. 4. There are some cases, where instead of a constant voltage output of the generator, there is required a constant current output. For instance, in certain electroplating systems, or in certain arc-lighting systems, when part of the load is taken off the line, or if some of the lamps are extinguished, the current must be kept

at the same value, regardless of how the generated voltage is affected.

In the arrangement of Fig. 4, a constant line-current is obtained by placing in series with the line a small resistor R. Across the terminals of this unit is connected a vacuum tube, the plate circuit of which completes the circuit of a shunt field winding. Now suppose some of the load is taken off the line. The current momentarily decreases; the generator voltage then goes up and the generator momentarily supplies more current to the line. But this momentary increase of line-current causes a momentary increase of the voltage drop across the resistance, so the grid voltage on the tube is increased. This causes an increase of plate-to-filament resistance within the tube, so that the current flowing through the shunt-field winding is decreased, the generated voltage is lowered and the line-current delivered is restored to its original value. Of course, these changes take place automatically, each one as fast as the other. If the circuits are properly proportioned, a very constant line-current can be maintained.

**REMARKABLE SENSITIVITY**

There are certain other applications of the vacuum tube which are very interesting on account of the fact that they permit measurements of extremely small distances and, by virtue of this faculty, also permit of measurement of extremely small weights. Used as such, the name *ultra-micrometer* is given to these arrangements. They were first introduced by Professor Whiddington of the University of Leeds, England, and depend upon the properties of an oscillating vacuum tube. There are two classes of ultra-micrometers, one class called *heterodyne-beat* ultra-micrometers, and the other called *zero-shunt* ultra-micrometers.

Fig. 5 illustrates the principle of the zero-beat ultra-micrometer. On the left, we have an ordinary Hartley oscillator. On the right, we have an oscillating detector, which may be of the type shown or of the three-circuit-tuner type. In the output circuit of this oscillating detector, we have a split primary transformer. An ordinary "push-pull" circuit transformer may be used effectively for this purpose. Now suppose we set the oscillator on the left oscillating at

(Continued on page 171)

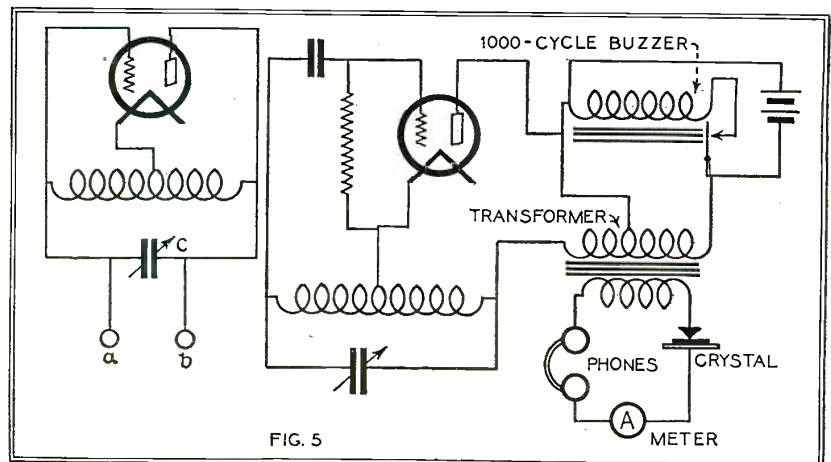

The "zero-beat" ultra-micrometer is one of the most sensitive measuring devices which has yet been invented. Two oscillating circuits are brought to a perfect balance; then the slightest alteration in either of the circuits becomes audible.

# Radio Novelties from Abroad and Home

### Camera Sketches of Late Developments in Radio, on the Largest and the Smallest Scales

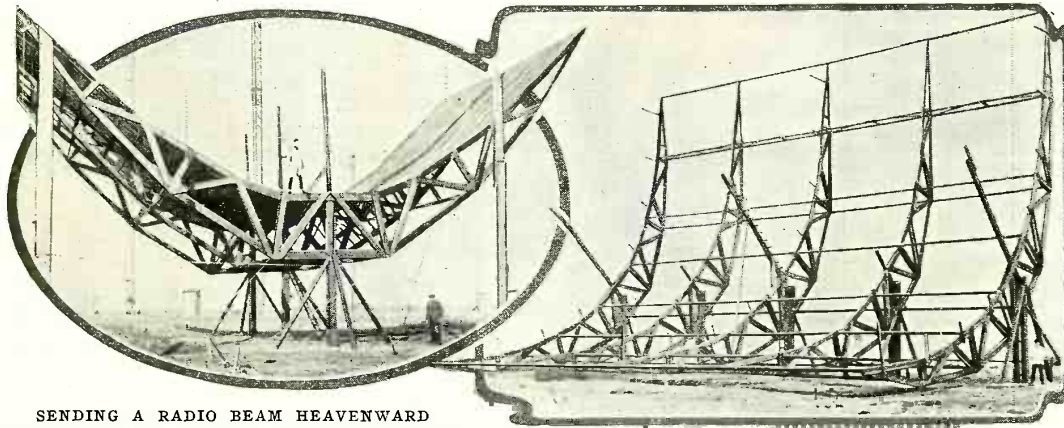

#### A SKIP-DISTANCE REGULATOR

The aerial system shown in the two views at the left has just been constructed at Nauen, Germany, for work with short waves. By regulating the angle at which they are sent against the reflecting layers in the upper atmosphere, it is believed that the waves can be projected so accurately as to be receivable with full force only at the desired station. The size of the reflecting system can be judged by comparison with the figure of the man.

© Wide World Photos.

#### SENDING A RADIO BEAM HEAVENWARD

The cover of RADIO NEWS for February, 1927, bore a somewhat sensational illustration of a vertical reflecting system for sending a radio beam at any angle. Many readers undoubtedly considered it fiction—but if so, it has been turned into reality, as the pictures above show. The frames above are erected to carry a short-wave aerial at their center (focal axis).

#### NOT A BURGLAR'S DARK LANTERN

As you would think at first glimpse, the curious apparatus at the left is the newest type of studio microphone.

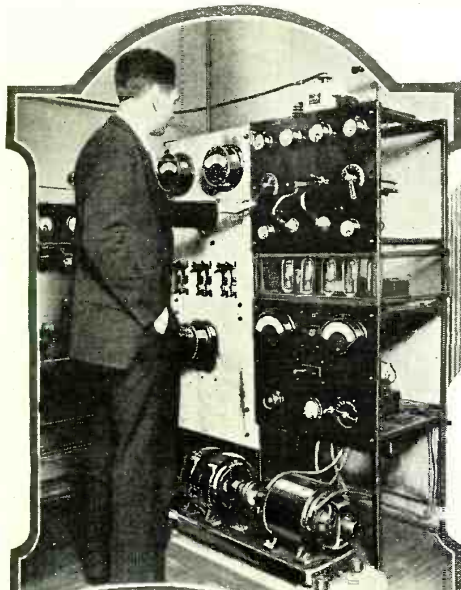

#### RADIO IN THE HOME

That's just it; William H. Reumann (left) has his broadcast station in his residence. The transmitter was built by Mr. Reumann, a well-known former amateur.



#### THE CONDENSER MIKE IN USE

Above, the new microphone as it is placed to pick up the program; Wishart Campbell at the keyboard in station CKGW, Toronto, Canada. The microphone comprises two metal plates, the capacity between which is altered by their vibrations in accordance with the sound received; the upright cylinder contains also a stage of A.F. amplification. The device is exceedingly faithful and delicate, and may replace the present familiar "birdcage."

#### REVERSING THE USUAL PROCEDURE

The housewife who puts the speaker in the kitchen while preparing a meal is no longer news; but here is Mrs. William H. Reumann at the mike of WWRL, Woodside (New York City) broadcasting household hints from her own kitchen. The Reumanns met in a studio, were married in one, and now they are living in a home which is also a studio.



© Herbert Photos, Inc.

List of Broadcast Stations in the United States

Table listing broadcast stations across the United States. Columns include Radio Call Letter, Broadcast STA. Location, Wave (Meters), Power (Watts), and Radio Call Letter, Broadcast STA. Location, Wave (Meters), Power (Watts). Stations are listed alphabetically by call letter.

THE list of stations here corresponds to the latest list of licenses issued by the Radio Commission at the time of going to press; and is subject to changes ordered by the regulating authority after June 10, 1928.

(Continued on page 157)



Five speakers of popular types, all free-edge except the double-fixed-edge cone in the center.

IT has been stated in radio periodicals several times of late that acoustic engineers have not kept abreast of the times in the design of loud-speaking sound reproducers. The articles in which this statement has appeared have pointed to the rapid strides made in the development of all other pieces of radio apparatus, many of which are now said to approach perfection. In comparison with this, they have explained, little is known about sound reproduction today that was not general knowledge in engineering circles five or ten years ago.

In the writer's opinion, the above statements are not entirely correct. It is true that considerable theoretical information relative to sound reproduction has been available for a number of years; but most of these data have not been applied practically until recently. And any engineer will not hesitate a moment in confirming the fact that a vast amount of work is required between the date of conceiving an idea and the date on which that idea has been developed to the point where it is commercially practical.

In the case of loud speakers, although few new principles have been discovered since the era of broadcasting, it cannot be denied that there has been a great amount of practical development. With the average speaker of five years ago, the radio reproduction of the human voice was hardly understandable; whereas, with the best speakers available today, it is difficult to detect a difference between the reproduction and the original.

In the above paragraphs it was not intended to give the impression that the modern loud speaker is distortionless, for

it is not. Practically all speakers which provide reproduction nearing the point of perfection are of enormous size and for this reason are not practical for home use. However, there are many excellent small-sized loud speakers available on the market today; but the problem still remains for engineers to develop a new principle which

looked over back copies of this magazine and several other radio publications, in order to recall to his memory all of the various types of speakers which have been used since broadcasting became popular. The articles in these magazines proved very interesting, and show clearly the steady and rapid progress which has been made in speaker design in the past few years. On the average of, at least, once every six months a new design of loud speaker was attracting public attention, and in a surprisingly large number of cases the new designs represented an actual improvement over previous types.

In order that the reader may understand better the present loud-speaker situation and appreciate the desirable characteristics of speakers to be made in the future, this article will endeavor to explain the principles upon which loud speakers operate, trace the development of radio loud speakers up to the present time, and point out the principal features of present designs.

#### HOW SPEAKERS OPERATE

It should not be necessary to explain that a loud speaker is a device for converting electrical energy into sound waves. However, the way in which this is accomplished is a mystery to a large number of radio fans. In the case of a radio receiver, the electrical energy which is used for the pur-

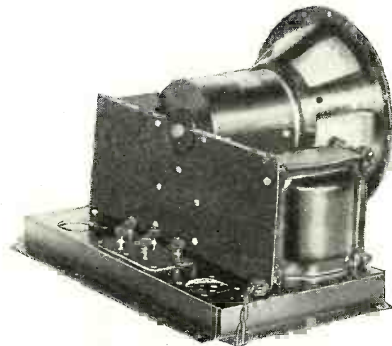
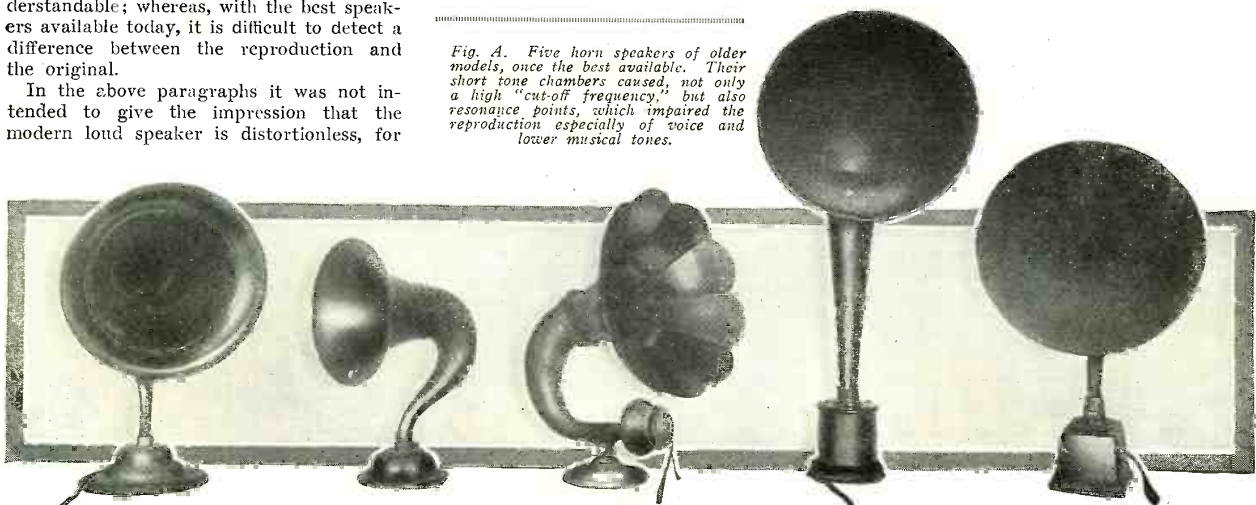

Fig. D. A typical electrodynamic unit and free-edge cone, built into an amplifier and "B" power unit.

permits the construction of a moderate-size speaker capable of delivering undistorted reproduction.

While preparing this article the writer

Fig. A. Five horn speakers of older models, once the best available. Their short tone chambers caused, not only a high "cut-off frequency," but also resonance points, which impaired the reproduction especially of voice and lower musical tones.



pose is a pure direct current to which has been added a pulsating D.C. component. It is the pulsating D.C. component of this current alone which is utilized by the loud speaker for producing sound, and it is the

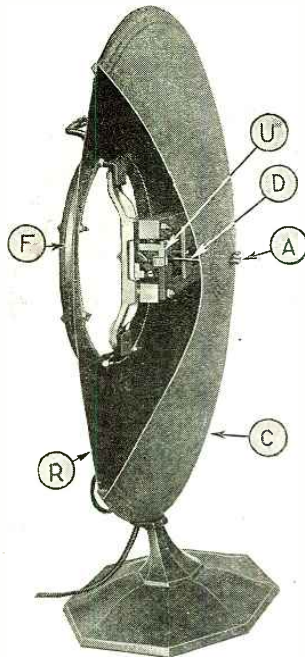

Fig. C. Cut-away view of double fixed-edge cone; showing mechanical construction: A, apex; C, front cone; R, rear cone; F, metal frame; U, speaker unit; D, driving rod.

sole purpose of the radio receiver to produce this current.

Pulsating direct current of the type mentioned is of a different character from that used for any purpose other than the transmission of sound waves. Current used for lighting, heating or power usually is constant at all times; that is, it is of a uniform frequency and of unchanging intensity. On the other hand, current which is used for sound transmission is of neither a uniform frequency nor amplitude, but it corresponds exactly with the sound waves. In other words, it is interrupted at a frequency which is equivalent to the pitch of the sound, and its magnitude varies with the volume of the sound.

With electrical energy available which duplicates exactly the desired sound waves, it may be seen that an electric motor is needed to convert the electricity into mechanical energy of precisely the same characteristics as to frequency and the variations in volume. The loud-speaker's driving unit is the motor which has been designed for this purpose. Of course, it does not cor-

respond to the usual design of electric motors; as the high inertia of a rotating machine makes it impractical to consider using it for sound reproduction, which requires almost instantaneous variations of frequency. Also, vibrating devices of the type used as loud-speaker driving units make the mechanical problem of converting the mechanical energy into sound waves much simpler.

At this point it should be explained that practically all loud speakers, and headphones as well, operate on exactly the same electrical principle. In a device of this type the electric energy produces in the magnetic field variations which correspond to the sound waves which are being reproduced. The magnetic energy is employed to cause an armature to vibrate, and the armature is coupled mechanically to a diaphragm which also vibrates. The diaphragm sets the air in vibration, thus producing sound.

From an electrical viewpoint there is very little difference between headphones and loud speakers, even though mechanically they may be not at all similar. Of course, the driving unit used in headphones is much smaller than that used in a loud speaker, but in some cases they are of exactly the same mechanical construction. In the case of large power speakers, however, the driving units are necessarily of very different design to permit the handling of the enormous output, which frequently is a thousand times as great as phones are ever required to produce.

super-sensitive phones which are capable of producing considerable volume. In each unit is a permanent magnet with coils of fine wire wound over the pole pieces. In the design illustrated in Fig. 1, the iron diaphragm is placed over the poles of the magnet and separated from them by a small fraction of an inch; while in the other an armature, which is coupled mechanically to a large mica diaphragm by a driving rod, is placed between the pole pieces.

Both phone units operate in the same manner. The coils of the unit are connected in series with the circuit in which the pulsating direct current is flowing; and the current varies the flux of the magnet, causing the diaphragm (directly or through the armature, as the case may be) to vibrate. It may be seen easily that the vibrations of the diaphragm must correspond to the frequency of the pulsating current, and, therefore, the pitch of the desired music is reproduced. Also, as the current varies in intensity with the volume of the sound, the amplitude of the vibrations will increase in the same proportion.

Most of the loud speakers on the market use driving units of the construction shown in Fig. 2. This is because this type of unit may be made larger, so that it will handle a greater volume of sound without overloading. However, in power speakers an entirely different type of unit is sometimes used. This type of unit operates on the principle of magnetic attraction, but employs an electromagnet instead of a permanent magnet. It is needed only when more than the average volume is required.

TWO GREAT TYPES

In mechanical operation all loud speakers in general use may be placed in one of two classes; namely, the "horn" and "cone" types. Although probably hundreds of different kinds of mechanical construction, which do not appear to resemble each other, are used in loud speakers, a careful analysis will show that there are only two operating principles.

In the horn type a small diaphragm sets a long column of air into vibration, and in this way the sound waves are concentrated. In the cone type a large diaphragm is used, and this sets vibrating a great amount of air, thus avoiding the necessity of the horn.

It is interesting to note the various stages of development through which the radio loud speaker passed before it reached its present stage of perfection. The first loud speakers offered by radio stores were merely makeshifts, and it is easy to understand the reasons. When broadcasting first started it was considered an experiment in home amusement rather than a necessity for home entertainment; and, as a result, the person who invested as much as twenty-five dollars in a complete radio installation was considered very extravagant. Secondly, the



Fig. 3 (left). An early speaker which employed a pair of phones as a driving unit. Fig. 4 (right). Another early speaker, with phone unit mounted in base.

TELEPHONE UNITS

Figs. 1 and 2 illustrate the mechanical construction of two popular types of phone driving units. That shown in Fig. 1 is the type found in the average pair of phones, and the one shown in Fig. 2 is used in

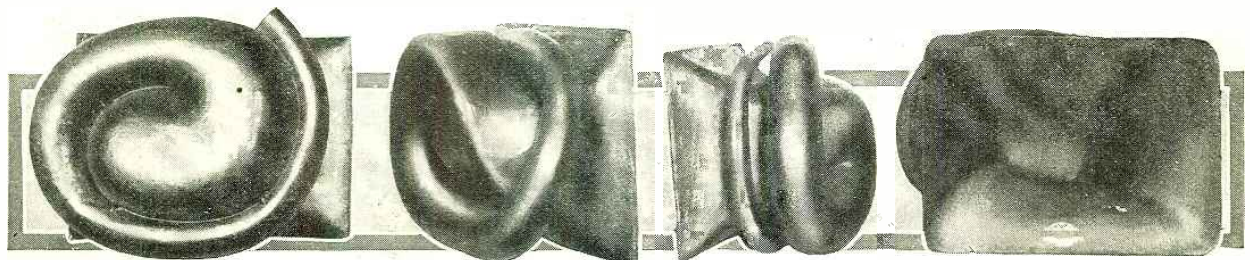

Fig. B. Four modern "exponential" horns, with tone chambers six to ten feet long, designed for building into a cabinet.

first broadcast receivers did not provide sufficient volume for satisfactory loud-speaker operation. And thirdly, the quality of music transmitted by the first broadcasters was so poor that the merits of a good speaker could not be appreciated.

When broadcasting first attracted public

set and obtain greatly amplified signals. This announcement almost doubled the public's interest in radio, and it also created the first demand for loud speakers.

EARLY STAGES OF EVOLUTION

One of the first loud speakers to appear on the market is shown in Fig. 3. As may be seen from the illustration, it is a short metal horn coupled to a pair of headphones. Needless to say, it gave very poor results; but most fans at the time were particularly pleased with the design, because it was possible to use the same pair of phones for individual receiving and with the loud speaker.

Figs. 4, 5 and 6 show three other types of loud speakers which were popular during this period. The speaker illustrated in Fig. 4 probably was made by a manufacturer of automobile horns, as it bore a marked resemblance to the latter. It was designed so that a standard phone unit could be fastened in the base. The speaker shown in Fig. 5 was a feature of the 5-and-10-cent stores, and consisted of a small cardboard megaphone with a coupling device which could be used for attaching a phone unit. Fig. 6 shows a coupling unit designed to combine a phone unit and the tone chamber of a phonograph as a loud speaker.

All of the speakers described above gave poor results as judged by present-day standards; but they seemed quite satisfactory at the time; as the available music was so distorted at the broadcast stations that further distortion by the loud speaker had scarcely any effect upon the quality. However, as the horns were of very short length, the "cut-off frequency" was very high; i.e., only the high-pitched tones were reproduced and the low tones were totally lacking. This caused men's voices, particularly, to sound very peculiar. Secondly, the phone units were unsatisfactory for the purpose, as they were easily overloaded and would rattle violently. Thirdly, the tone chambers were inefficiently designed and "resonated" at some frequency, thus causing severe distortion.

As radio grew more popular the transmission of broadcasters was improved and better loud speakers were required. In answer to this demand horn speakers of the type shown in Fig. A were developed. These speakers were entirely satisfactory at the time but they would not begin to measure up to present standards. All of these horns were equipped with larger loud-speaker units which would not overload as easily and the tone chambers were longer, thus lowering the cut-off frequency. However,

most of these speakers would resonate at some frequency.

As broadcasting improved the horn speakers of the type illustrated in Fig. A became less and less popular because of the distortion caused by the resonating of the horns, and because of their inability to reproduce low tones. Attempts were made to

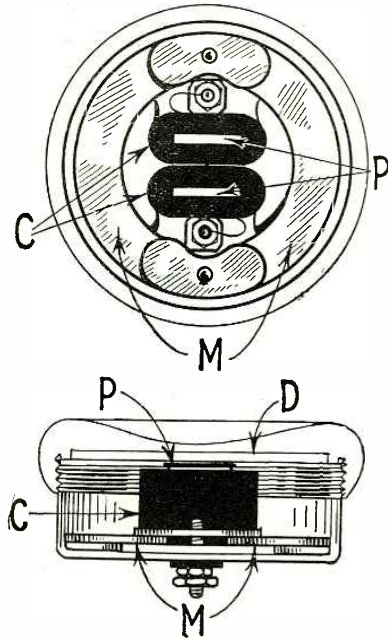

Fig. 1. Drawing showing mechanical construction of standard phone unit: M, permanent magnets; C, coils of wire; P, pole-pieces of magnet; D, diaphragm.

attention loud speakers were unknown. Fans would build simple crystal receivers, costing less than ten dollars, complete with aerial and headphones, and would listen to phonograph music broadcast by a local station. Later, some experimenters constructed simple regenerative receivers, which enabled them to listen to distant stations with headphones when using only one tube. Of course, with both of these arrangements loud-speaker reception was impossible; and there were at least fifty installations of this kind for every more elaborate receiver then in existence.

The first step forward for broadcasting was when the reflex circuit was presented to the public. Radio experts explained that it was possible to add two inexpensive items—an A.F. transformer and a crystal detector—to a simple one-tube regenerative

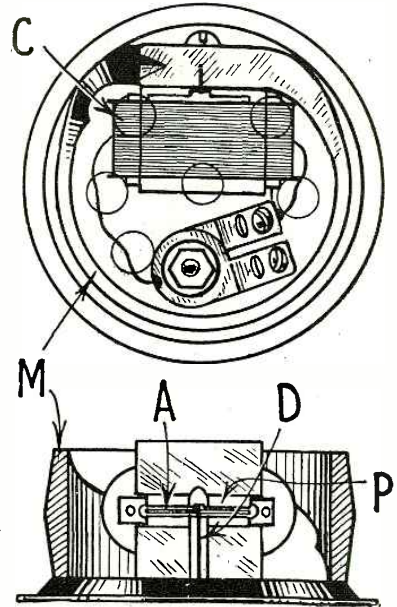

Fig. 2. Diagram showing mechanical construction of a super-sensitive type of phone unit: M, magnet; C, coil; A, armature; D, driving rod; P, pole-pieces.

make horns of non-resonating material, such as wood and paper-pulp, but the results were not wholly satisfactory. The first solution of the problem was found in the development of the cone speaker.

THE CONE ARRIVES

In the first part of this article it was explained that the cone-type speaker operates on an entirely different principle; namely, that of vibrating a large diaphragm which acts on a great volume of air. With this type of speaker the tone chamber is eliminated and this avoided many of the difficulties which had been experienced with loud speakers in the past. These speakers were, therefore, very satisfactory; as, when an efficient unit was used, the reproduction would be fairly uniform over a wide band of frequencies. Also, it may be said that the

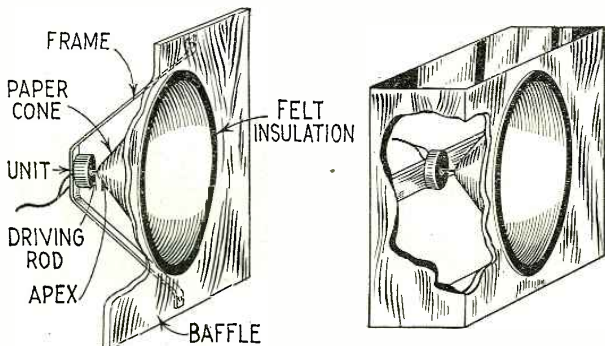

Fig. 9. Two types of free-edge-cone speaker construction; left, the baffle-board type and, right, the box-baffle type. The baffle prevents interference of sound waves from the two surfaces.

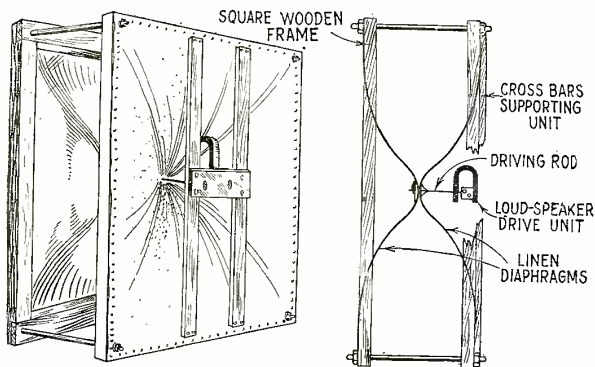

Fig. 10. These drawings give details of the new linen-diaphragm loud speakers. This type of construction provides a very sensitive reproducer when suitably balanced and equipped with a high-quality unit.

cone is still considered one of the most popular types of speakers.

After the development of the cone many "trick" speakers were introduced. A majority of these did not provide any improvement in sound reproduction, but some presented a more attractive appearance. All speakers of this class, whether they are of conical shape or not, operate on the prin-

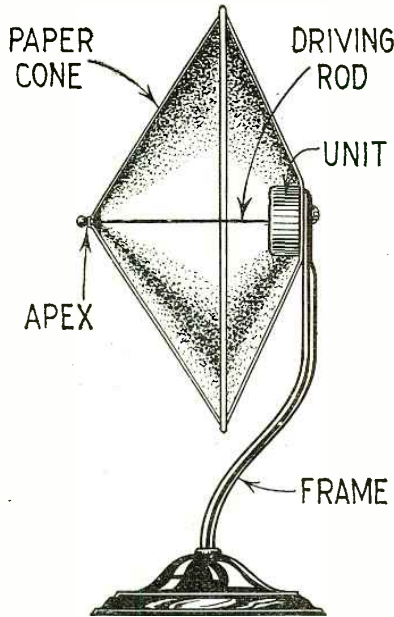

Fig. 8. The usual double-fixed-edge cone is constructed as pictured above, whatever its external appearance.

ciple of vibrating a large diaphragm; and, therefore, may be considered members of the cone family. They have been presented in many odd forms, including pictures for the wall which concealed a large sounding board of paper or balsa wood, table lamps with a vibrating shade, ship models with vibrating sails, Lindbergh planes with vibrating wings, etc.

After the development of the cone, the design of speakers was rather standardized until power amplifiers came into general use, and these called for a further improvement in loud speakers. With a power amplifier it was found that, although the low bass notes were amplified by the tubes, the small-sized cone-type loud speakers were unable to reproduce these tones at their full volume. Therefore, engineers started work on several new designs of speakers which would provide practically uniform reproduction over the entire band of audio frequencies.

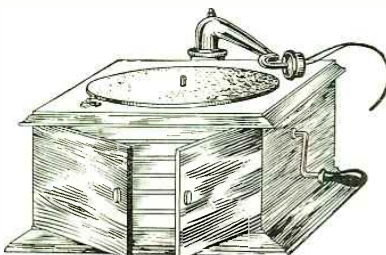

Fig. 6. A speaker unit and adapter convert a phonograph tone chamber into a loud speaker. With an exponential horn good results may be obtained.

These speakers are in most general use today, and each type will be considered individually, as follows: exponential horns; fixed- and free-edge cones; tense- (linen) diaphragm types; and the electrodynamic-drive cones.

The first step taken during this trend of development in loud speakers proved to be a great surprise to everyone interested in radio. This is because the improved speakers were of the horn type, and it was popularly thought that radio horns had been discarded several years before because they are poor reproducers of sound. However, the new horns are very different from the speakers of this type which had been used in the past. They were first called "orthophonic" horns but later they became known by the name of "exponential" horns. They are much larger, of a different shape, and were designed mathematically according to a definite scientific principle.

The first exponential horns were designed especially for use in modern phonographs, and these attracted the attention of radio engineers. It was found that exponential horns could be designed to radiate uniformly all audible tones, and also that the undesired resonance of the horn could be reduced to practically zero by correct construction. Therefore, with a horn of this type, the only thing to prevent distortionless reproduction is the characteristics of the loud-speaker unit. However, the size of the horn is another factor which limits its utility, but this will be considered in another paragraph.

An exponential horn may be described as a tone chamber whose area of cross section is multiplied by a constant figure for each unit of length, and this "rate of expansion" determines the "cut-off frequency" of the horn; that is, the frequency down to which the horn provides uniform concentration of all tones. Of course, the horn will reproduce tones below this frequency, but they do not pass with equal facility. The second important factor which must be considered in the design of exponential horns is the diameter of the cross section at the bell. This diameter should be equal to one-quarter the wavelength of the cut-off frequency, in order to avoid resonance. The shape of a true exponential horn is illustrated in Fig. 7.

In this article space does not permit a complete explanation of the design of horns of this type; but it may be said that the two factors mentioned in the above paragraph make necessary a horn of great length for the reproduction of low tones. Because of this fact it is entirely impractical to consider constructing a horn for home use which would provide undistorted reproduc-

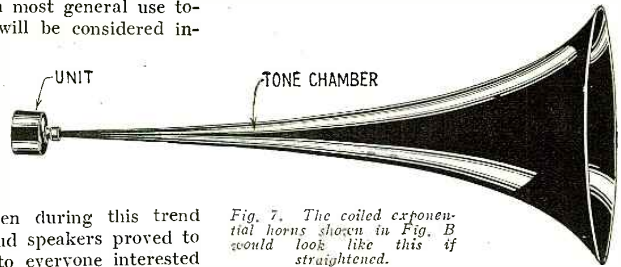

Fig. 7. The coiled exponential horns shown in Fig. 8 would look like this if straightened.

tion of all audio frequencies. Such a horn would even be too large for use in a theater, as for a 16-cycle cut-off the horn would be over 65 feet long and 17½ feet in diameter at the bell. However, by coiling the tone chamber, it is possible to reduce the size so that a horn may be made for home use which will reproduce well frequencies below 100 cycles; and such horns answer practically all requirements.

In Fig. 8 pictures of five different commercial exponential horns are shown. These horns are of the coiled type and have air chambers from six to ten feet in length.

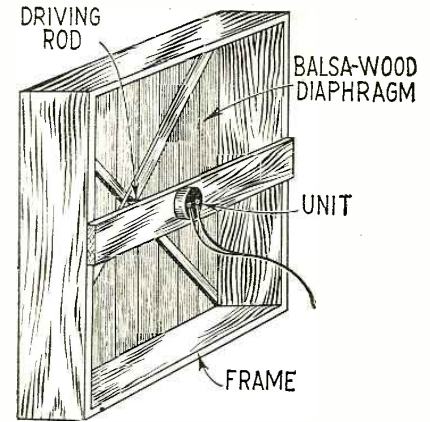

Fig. 12. A wood-diaphragm speaker is a highly efficient reproducer, and may also be quite decorative. Frequently one is employed as the backing of a tapestry or painting.

Any of these horns, when equipped with an efficient loud-speaker unit, makes an excellent reproducer of sound. They are not of attractive appearance, but have been designed only for use inside a radio cabinet.

MODERN CONES

The second improvement in loud speakers was in the development of the fixed-edge cone type. It was found that the low-note (Continued on page 179)

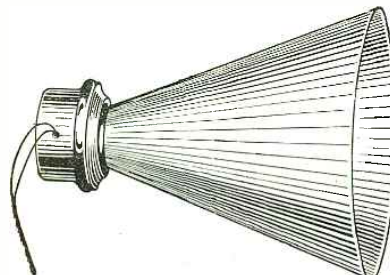

Fig. 5. An early "5-and-10 store" design of loud speaker. The horn is an ordinary paper megaphone, to which a unit is attached.

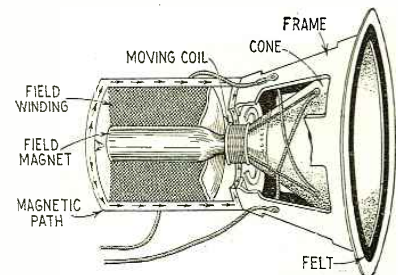
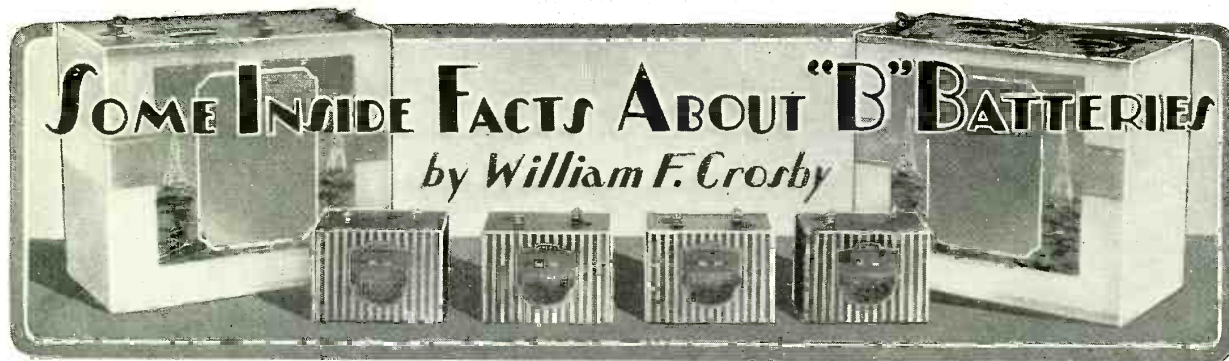

Fig. 11. Constructional details of the standard electrodynamic-speaker unit; it requires current to keep its field windings excited.



**D**ESPITE the fact that socket-power units and A.C. tubes have achieved great popularity, the old-fashioned dry cell for "A," "B" and "C" voltages is still extremely popular; not alone in rural communities, but also in many cities and suburban towns where owners of radio sets desire to use their old sets and refuse to be led into changes which might involve a great outlay of money. If a man has a radio set which is working properly, giving him all that he can desire in the way of quality and distance, he may rightfully enough reason that any additions or changes might involve a change in his set's performance; hence, he is loath to take a chance.

Dry cells for radio use must be made

carefully of the best possible materials, in order that they may stand up for a considerable period of time and be able to deliver their maximum voltage over a period of many months. This is particularly true of the dry "B" battery, which the average set owner is not anxious to keep changing all the time. For this purpose it is interesting to look into the manufacturing processes involved and the care with which these batteries are put together by manufacturers.

Each manufacturer has his pet formula and his rigid specifications. More than half the secret of long life is absolute uniformity throughout the cells which make up the individual "B" battery. One weak or defective cell will make trouble within a short

space of time, and a shipment of such batteries might be the direct cause of a considerable loss of business. The average "B" battery used on the average set under ordinary operating conditions should last anywhere from nine months to a full year; and there are many cases where such batteries have lasted over periods considerably longer.

**WHAT IS A BATTERY?**

A "B" battery is composed of a number of small 1½-volt units; each a miniature dry cell such as used for doorbell-ringing purposes, but of course much smaller. See Fig. 1. In a 45-volt block of more or less standard design there are 30 of these cells; each cell consisting of a seamless zinc can in the center of which is placed a carbon stick, the remaining space being packed with a mixture of manganese, graphite and sal-ammoniac. It is essential that the can be seamless for, with the older type of construction, where the zinc was soldered, an electro-chemical action would soon set in between the unlike metals at the soldered joints. The result was that this joint would soon corrode and render the battery useless.

Strictly, there is no such thing as a really dry battery; for the mixture just mentioned is moist and must remain moist as long as the battery is to last. One really dry cell in the series of 30 in such a battery would make the whole block useless, regardless of the condition of the other twenty-nine. It is therefore apparent that care must be exercised to keep air out of the cells. This is also one of the reasons why most manufacturers request that their batteries be kept away from heat.

**MANUFACTURE**

The mixture of manganese, graphite and sal-ammoniac is packed around the carbon stick, wrapped by hand in a special material, and then tied tightly to keep it from breaking and causing an internal short-circuit. This unit is called the "bobbin" and comprises the positive element of the cell. It is placed in the seamless zinc can and the electrolyte (in this case a solution of sal-ammoniac or ammonium chloride) is poured around it. A washer of non-conducting material is placed on top of this and the can is then hermetically sealed with a prepared wax. This performs the function of keeping the air out of the cell and prevents rapid drying up.

The individual cells are carefully assembled in a box with waterproof separators between them. Then the electrical connections are made with more than 60 soldered joints. Throughout the entire assembly, the unit is inspected occasionally and double-checked to insure uniformity.

The life of a "B" battery depends upon

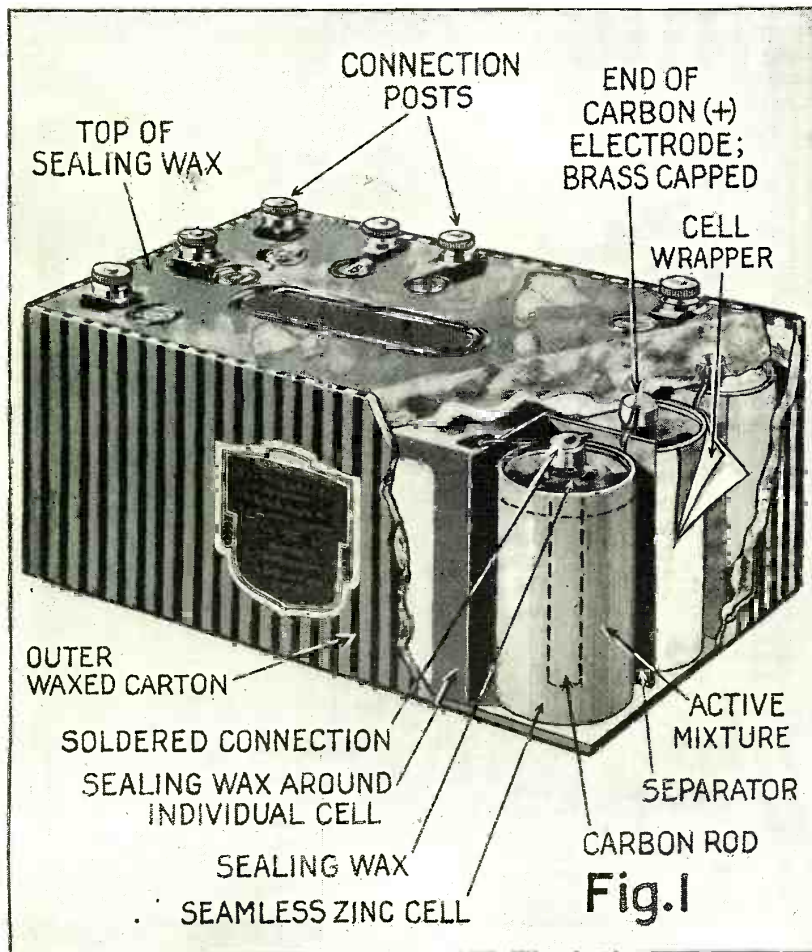

This drawing shows the internal construction of a typical "B" battery of the individual-cell type. The unit contains 15 cells and develops 22½ volts.



the *depolarizing* agent used in its construction, more than on any other single factor. In most of the factories the exact formula for this agent is a carefully-guarded secret. The purpose of the depolarizer is to prevent the formation of a film of hydrogen gas, which naturally accumulates about the carbon, or positive, pole of the cell when the current is flowing. Since hydrogen is a non-conductor of electricity, the active surface of the positive pole in contact with the electrolyte gradually decreases in area, causing the *internal resistance* of the cell to rise until a point is reached where it is no longer possible for current to flow. Part of this reduction in current is caused by the fact that the hydrogen (which causes the cell to become *polarized*) also sets up a flow of current within the cell itself, in opposition to the normal flow. When the external circuit is opened, the flow of current within the cell itself should cease, theoretically; and the more complete the actual cessation, the longer the cell will last when on the shelf.

**LENGTH OF LIFE**

All the time current is flowing, the zinc container, or negative pole, in contact with the electrolyte, is slowly disintegrating. This disintegration, comparable with the burning of fuel, liberates the energy contained in the battery. If a short-lived battery (one which has not been short-circuited or subjected to abnormal drain) is opened, the zinc cartridge or can will be found in almost perfect condition, with no evidence of corrosion. On the other hand, if a long-lived battery is opened, the zinc shell may be found to be badly corroded. In the first case, because of either polarization or the drying up of the electrolyte, the positive pole had virtually become insulated from the negative; consequently the cell became useless in short order. In the second case, the depolarizing agent and the electrolyte maintained their efficiency to the end. It should be remembered that it is the disintegration of the zinc that causes the current to flow and naturally enough, the area, thickness and purity of the metal will have a large bearing on the useful life of the cell.

"B" batteries, to be satisfactory, must have the following characteristics: *long shelf life*, long service life, freedom from noise, and uniform quality. A battery which can render long service after long periods of idleness is said to have a "long shelf life." The word *service* or *service life*, when used in connection with batteries, is usually taken to mean the ampere-hours or milliamperere-hours delivered by the battery before the voltage falls to a fixed value. A 45-volt battery, for example, has reached the end of its useful life when the voltage has dropped to about 34. At this voltage the internal resistance of the battery becomes fairly high and, although it may still appear serviceable, it is far better to replace it with a newer battery.

Batteries used for a "C" supply, or "negative bias" on the grids of vacuum tubes, have a service life practically equal to their shelf life; for the reason that they are called upon to deliver but a very small amount of current. The service life of a battery is dependent upon the way it is used as much as upon the quality of the materials entering into its construction. Any battery, no matter how well made it is, if called upon to deliver too heavy a load, will necessarily have but a short life.

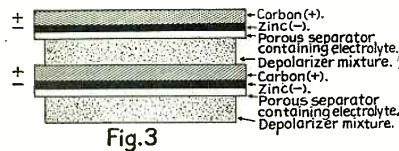

**Fig. 3**  
The elements of the "B" battery of the layer-constructed type. The carbon is painted as a thick layer directly upon the surface of the zinc plates.

**SHORT CIRCUITS**

The useful life of a "B" battery is often prematurely ended by a short-circuit, without the owner's knowing when or how it happened. The cells of a short-circuited battery will be all, or in part, corroded, the electrolyte will generally leak out and the pressure of a fingernail against the zinc shell will often be sufficient to break through it, especially near the top. (This part of the shell is where the upper part of the bobbin ends and corrosion there is more pronounced than anywhere else.)

However, in the case of batteries which have become shorted after having delivered a great part of their energy through normal use, a subsequent short-circuit is generally not sufficient to cause any change in the appearance of the zinc.

There are other methods of determining in the laboratory whether or not a battery has been subjected to a short circuit or an extraordinary drain; but these are too

complex to be worth mentioning in this article.

"Internal shorts" may be found in a "B" battery; but due to the rigid inspections made in factories where good batteries are put together, these are extremely rare. In the case of an internal short, a single cell, or probably a few, will show a low voltage and the balance will show their normal voltage of 1.5 or 1.6 volts.

It is also possible to short-circuit one half of a 45-volt battery and not the other half; that is, from the negative to the center 22½-volt tap or from this tap to the 45-volt terminal at the other end. This is explained by the fact that batteries of this type are usually composed of two separate blocks of 22½-volts each, connected together by a wire.

Sometimes, certain tap wires are taken to the set from one of the intermediate taps on a battery, such as the detector tap where a "soft" tube is used. This particular section of the battery will have a greater rate of discharge than the others, and will therefore be exhausted sooner. A short occurring in any of these tapped sections would exclude that part from the circuit in very short order.

**THE PIONEER IDEA REVIVED**

One manufacturer of "B" batteries has brought out a source of voltage which goes  
(Continued on page 164)

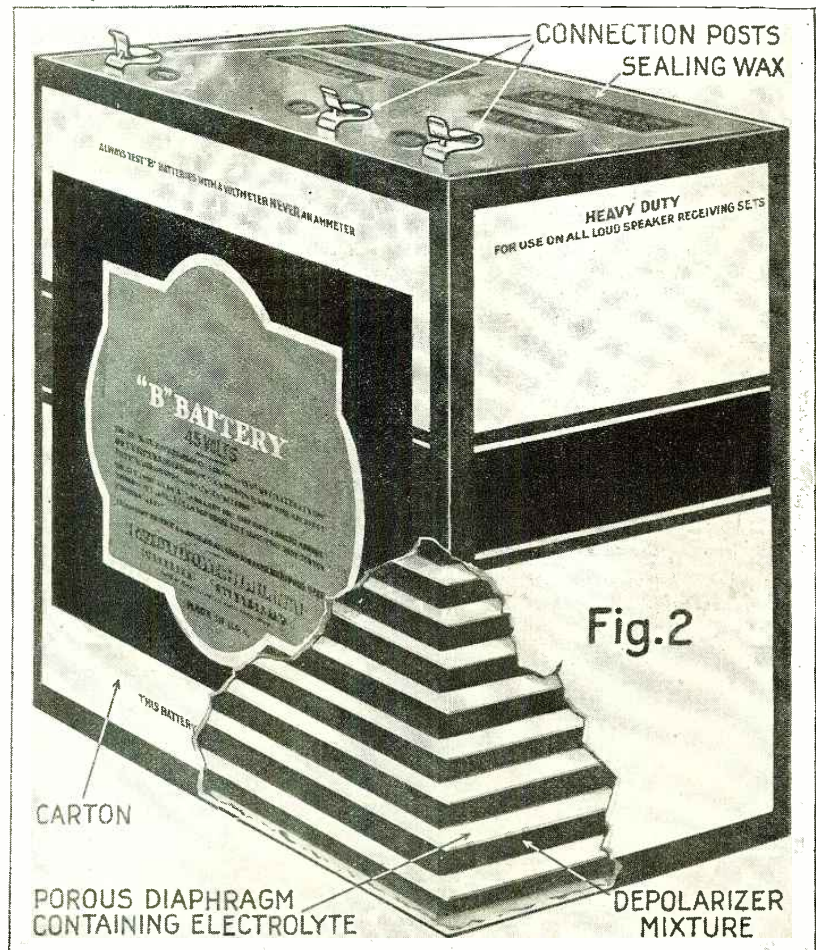

**Fig. 2**  
What a layer-constructed "B" battery would look like if one corner of the outer carton were cut away. This model develops 45 volts.

# The Radio Beginner

## A Two-Tube Reflex Receiver of Simple Construction

**H**UNDREDS of different types of receivers have been described in radio periodicals and newspapers during the last few years, and many of these have attracted considerable attention from constructors. However, almost without exception, the description of a good reflex circuit excites ardent enthusiasm on the part of many readers. Probably this is because everyone considers the reflex the ideal circuit from the viewpoint of economy, and hopes that some day a perfect receiver of this type will be developed.

In some ways the reflex circuit may be compared with a perpetual-motion machine, for there is an attempt on the part of the designer to obtain something for nothing. Of course, this is impossible; but there is no question about the fact that with circuits of this type greater volume is obtained from a given number of tubes than is possible with other methods. Therefore, the cost of parts, and the cost of operating the set, is a minimum, considering the results obtained.

### WHAT IS "REFLEXING?"

Before continuing further with this article, the principle upon which all reflex receivers operate will be explained. In all circuits of this type the reflexed tubes are called upon to do double duty; that is, they operate as both audio- and radio-frequency amplifiers. In the case of a three-tube reflex receiver, for example, the circuit would be arranged so that the three tubes act first

as R.F. amplifiers, then the energy is rectified by the detector, and returned to the beginning of the circuit, thus causing the tubes to operate a second time as A.F. amplifiers. In this way, with three tubes, it is theoretically possible to obtain results which compare with those delivered by a six- or seven-tube receiver.

At this point of the explanation the question asked most frequently is: "Why are not reflex circuits used more generally if they possess exclusively this economical feature?" The answer is, that a large number of designers of reflex circuits have become

Fig. A. The simplicity of the Two-Tube Reflex is apparent on its panel. While there are two tuning controls, they should keep in step over the waveband. R1 controls volume.

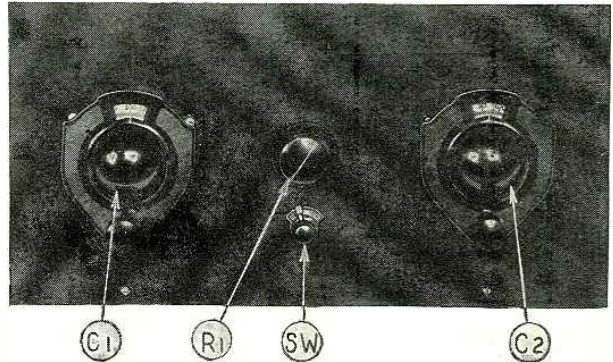

too miserly in their attempt to obtain maximum output from each tube, and, as a result, have impaired the quality of performance. However, if builders were satisfied with slightly less than double performance from their tubes, the over-all results pro-

duced by the receiver would be much more satisfactory.

The reflex receiver which is described in this article is a two-tube set, but it does not provide five-tube results. In building the receiver, the designer endeavored to secure the maximum from each stage, but was careful not to overload any circuit or tube. As a result the receiver gives excellent performance, but the results more nearly correspond to those obtained from the usual

three-tube receiver.

In circuit design the receiver employs a stage of reflexed R.F. amplification, a crystal detector, a stage of reflexed transformer-coupled A.F. amplification, and a straight stage of transformer-coupled A.F. amplification. Semi-power tubes are used in each stage to prevent overloading, and no attempt was made to combine a second R.F. stage with the second A.F. stage; as this would have an undesirable effect on the performance of the receiver.

### SIMPLE AND COMPACT

The receiver is very simple in operation. There are only two tuning controls, one volume control and a battery switch mounted on the front panel. The two tuning dials control the variable condensers connected in the R.F. and detector circuits. The volume control is a variable high resistor in the grid return circuit of the first tube. In tuning it will be found that readings of the two dials closely approximate each other for all wavelengths in the broadcast band.

The small size of the set is another important feature of the design. The front panel is only 13½ x 7 inches, and all the parts are mounted on a wooden baseboard 6¾ inches deep. The total weight of the set is only 6½ pounds, but this figure does not include a cabinet. These facts make this set ideal for semi-portable use, as a

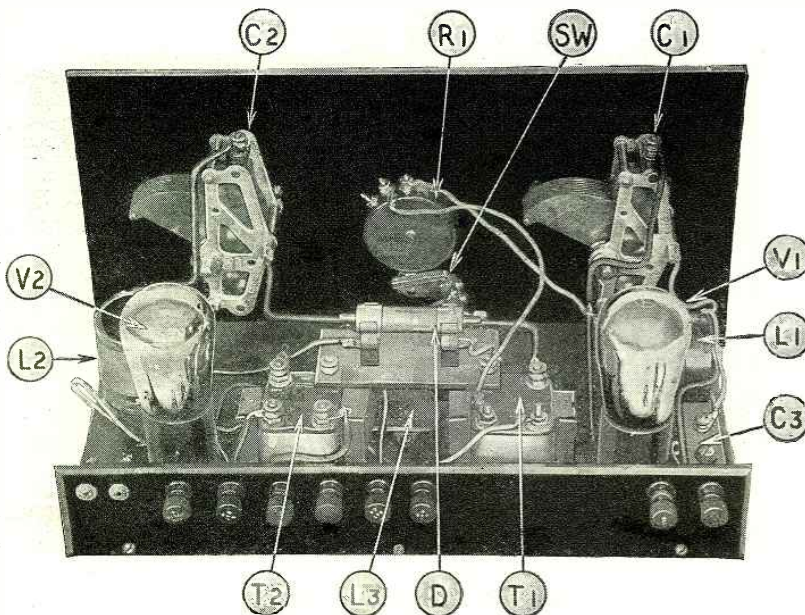

Fig. B. A rear view of the Two-Tube Reflex Receiver..

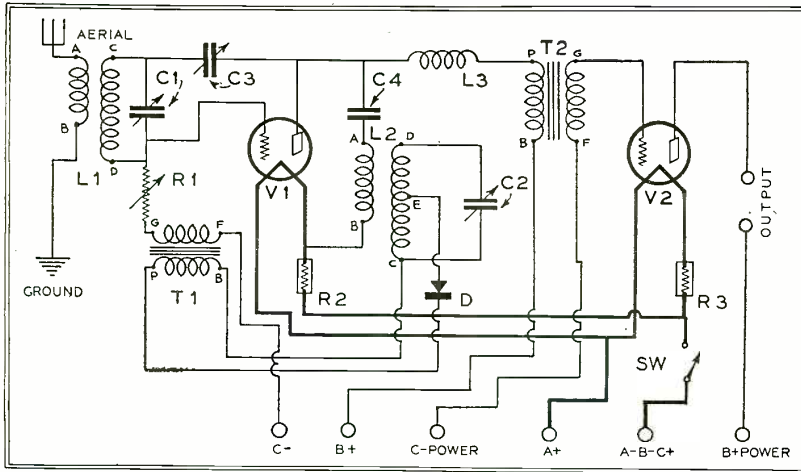

Fig. 1. This circuit diagram shows the characteristic appearance of a reflex circuit. Parts are lettered as in the list below and in the illustrations.

set of this type, complete with batteries, could be transported to a summer home or camp without difficulty. Since only two tubes are used, it would not be expensive to operate both the filament and plate circuits with dry batteries for short periods of time.

The construction of the receiver is very simple, and a novice should have no difficulty in building a duplicate of the set shown in the illustrations. In fact, it was designed especially to provide an inexpensive set for the beginner to start with. All parts are mounted on a wooden baseboard, with the exception of the instruments on the front panel, and all the wiring is above the base. Therefore, practically the only tools required when building the set are pliers, screwdriver and soldering iron. Of course, a few holes are required in the front panel, which is of bakelite, but the store where the panel is purchased will drill these, if requested to do so.

**PARTS REQUIRED**

- The first step in building the set is to secure the necessary parts: The following is a complete list of the apparatus required: Two variable condensers, .00035-mf. (C1 and C2);
- One adjustable condenser, 2 to 25 mmf. (C3);
- One fixed condenser, .00025-mf. (C4);
- One antenna coil, homemade (L1);
- One R.F. transformer, home-made (L2);
- Two A.F. transformers, 3½:1 ratio (T1 and T2);
- One R.F. choke coil, 85-millihenry (L3);
- One crystal detector, carborundum type (D);
- One volume-control resistor, 0-500,000-ohm (R1);
- Two filament-ballast units, 5-volt, ½-ampere type (R2 and R3);
- One battery switch (SW);
- Two tube sockets, UX type;
- Two vacuum tubes, 112A type, or one 112A type and one 171A type (V1 and V2);
- Two tuning dials, vernier type;
- Eight binding posts;
- One baseboard, 6¾ x 12¾ x ¾ inches;
- One bakelite front panel 7 x 13½ x 3/16 inches;
- One binding-post panel, 2 x 12¾ x 3/16 inches;
- One detector panel, 3 x 1¾ x 3/16 inches;

- Two phone-tip jacks;
- Flexible insulated connecting wire, screws, solder, coil mounting brackets, etc.

**No. 60**

*A complete set of large working blueprints, with the list of parts used in the original Two-Tube Reflex Receiver described here, will be given free to anyone writing in or calling at this office for them.*

*Ask for Blueprint No. 60.*

RADIO NEWS  
FREE  
BLUEPRINT  
ARTICLE

**MAKING THE COILS**

As the coils are home-made, these must be wound before starting the construction of the receiver. Both coils are wound on tubing 1⅞ inches in diameter, and a length of 2¼ inches is required for each coil. The tubing should be bakelite or hard rubber;

**MOUNTING AND ASSEMBLY**

After winding the coils the next step is

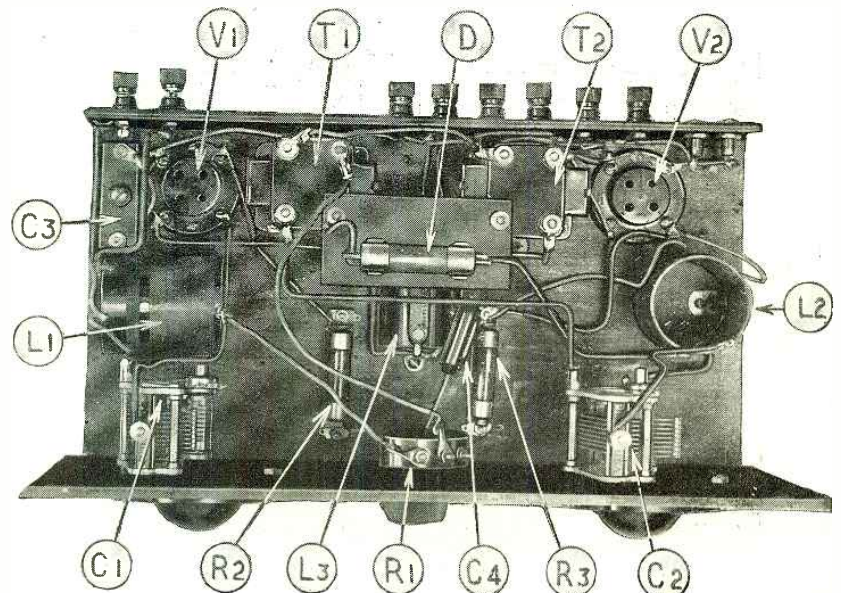

Fig. C. This top view shows the actual size and position of all parts.

but a cardboard tube may be used if nothing better is available. However, if a cardboard form is used it should be painted with collodion before it is wound with wire.

For winding the coils No. 28 D.S.C. wire is used throughout. In making the antenna coil (L1) start the secondary winding about ¼-inch from the end of the tube and wind 76 turns of wire. A space of ¼-inch should be left between the end of the secondary and the beginning of the primary winding, which consists of 15 turns of the same size wire. Also, it is important to make sure that the primary and secondary are both wound in the same direction.

The R.F. transformer (L2) is very similar in construction to the antenna coil, but the windings have a different number of turns of wire, and the secondary winding is tapped at one point. The secondary coil is started ¼-inch from the edge of the tube; it consists of 56 turns of wire and it is tapped at the 24th turn from the beginning of the winding (32 turns from the end nearest the primary winding). The primary winding has 22 turns of wire and is wound in the same direction as the secondary.

After winding the coils they should be painted with collodion to protect them from moisture. Then, four holes should be drilled in the tube ½-inch apart and ¼-inch from the edge at the primary end of the coil. These holes are for the various wires of the coil to pass through and they should be marked "A," "B," "C" and "E," respectively. The wire from the outer end of the primary winding passes through hole "A," and the wire from the inside of the primary winding through hole "B." The wire from the inner terminal of the secondary passes through hole "C," and hole "E" is for the wire from the tap in the secondary winding of the R.F. transformer. The wire from the outside end of the secondary winding is not brought to the base but passes through a hole marked "D" at the other end of the tubing. It is highly important that the various wires be correctly marked, as these markings are followed in wiring the receiver.

drilling the panels. In the front panel four large holes, 7/16-inch in diameter, are required for the shafts of the instruments mounted on the panel, and eight small holes for mounting screws. The panel layout shows the exact position of these holes. The other layouts give details for drilling the

binding-post panel and the crystal-detector panel. With the panels drilled and the coils wound, the assembly of parts may be started. First, mount the parts on the front panel. Both of the variable condensers (C1 and C2) are of the one-hole mounting

type, but three mounting screws are needed to prevent the frame of the vernier dial from turning. Both the resistor (R1) and the battery switch (SW) are of the single-hole mounting type. The parts on the baseboard are all fast-

(Continued on page 168)

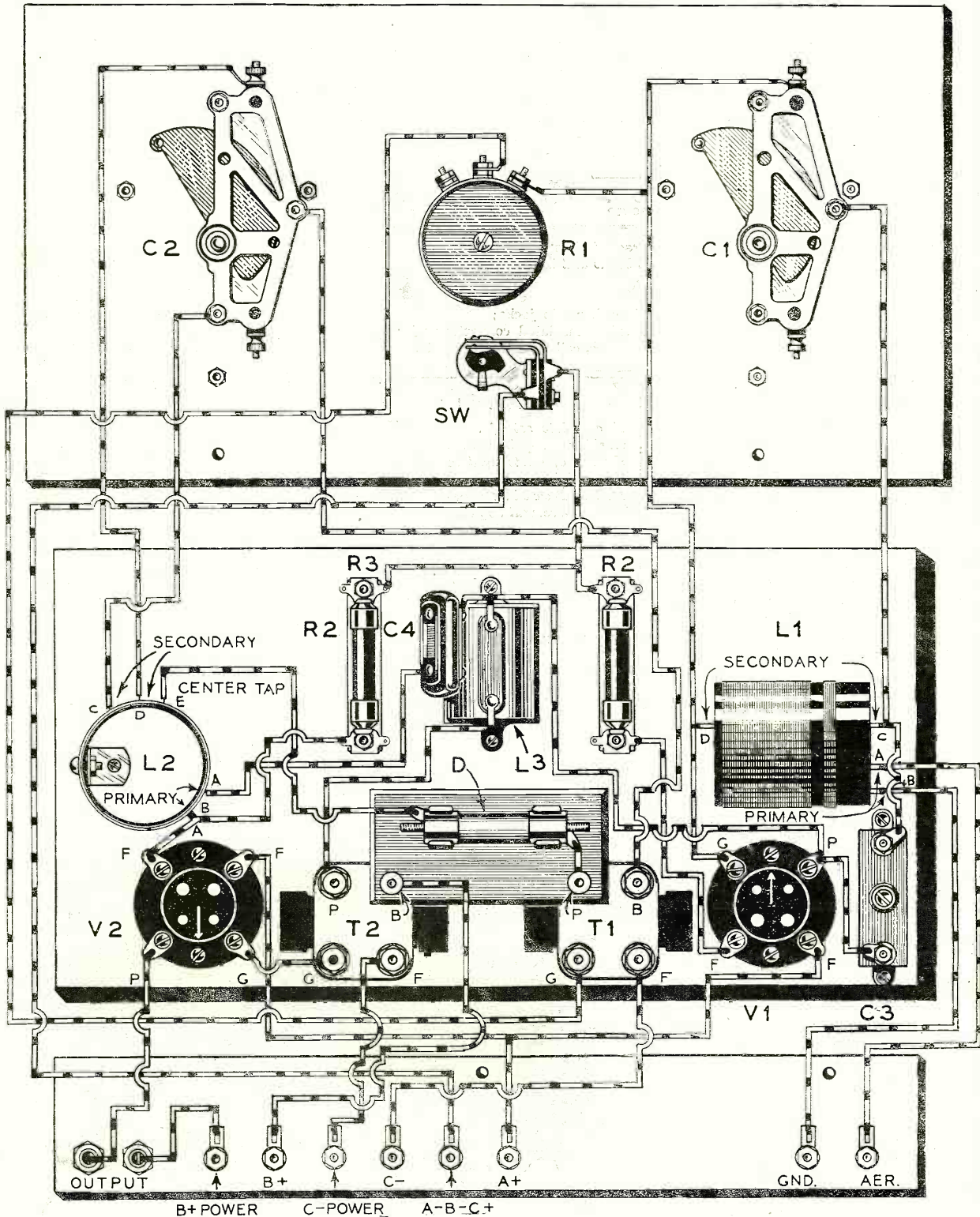

Fig. 2. Pictorial wiring diagram, showing front panel and baseboard of the Two-Tube Reflex. All wiring is in plain view. The small panel for the detector D is held by the binding posts B and P of the A.F. transformers.

# A Booster Unit for the Browning-Drake

Details of a Home-Made Device Incorporating One Stage of R. F. Amplification Which Will Add to the DX of this Excellent Receiver

By C. A. Oldroyd

**F**EW sets and circuits have enjoyed the great popularity of the Browning-Drake or Roberts type of receiver; and it looks as if sets of this design will win even more friends in years to come.

A well-made receiver using one stage of R.F. and a regenerative detector, with two stages of audio, is a remarkable distance-getter; and the DX fan whose purse is not long enough for an eight-tube "super-het" will find this set, which uses only half the number of tubes, an excellent substitute. Precision-made units make construction easy and certain for the beginner; the completed set need not fear comparison with high-grade factory-made receivers. On the other hand, the experienced radio constructor may build many of the parts easily.

The writer has been a Browning-Drake enthusiast for some time, since he is particularly interested in DX work and transatlantic reception (from the European side of the "pond") he finds the circuit hard to beat for this class of work. During the winter, even on nights when static was severe and code interference from ships most annoying, his "fouy-tuber" located in Barrow-on-Furness, England, regularly brought in American stations, usually at loud-speaker strength.

But, there were still some unresolved whistles which defied the operator and, to get still greater range, an experimental "booster" was rigged up. This consisted of one additional stage of R.F. amplification ahead of the receiver proper; it adds a tuning control, certainly, but tuning is not more difficult than with a standard three-dial neutrodyne, for instance. Also, it may be disconnected easily when not needed for DX work.

### A DX-BRINGER

The addition of the booster extended the range of the already very-sensitive set considerably, and DX work became a much more comfortable indoor sport than before. Without the booster, some weak signals had to be wrestled with for half-an-hour or more, before clear reception was possible; with the booster on the job such signals could be pulled in fairly easily.

The booster improves selectivity as well, and—last, but not least—it is easy to build and its cost is very moderate.

To give one or two examples of the sensitivity of the new set; on a roughly-made loop, stations over 300 miles away came in with good volume on the speaker. With an outdoor aerial, the set has, of course, a much greater range.

The original booster unit was completed late one night, and duly connected up. All English broadcast stations had by this time shut down, and even the Spanish stations with their late operatic programs were off the air. A healthy whistle showed that somewhere a radio station was busy; a few adjustments—and dance music came in with good volume on the speaker. At last the announcer—"Station WIOD, Miami, Florida." This station is well over four thousand

and miles from the writer's location, and its reception was a good omen for the possibilities of the booster unit.

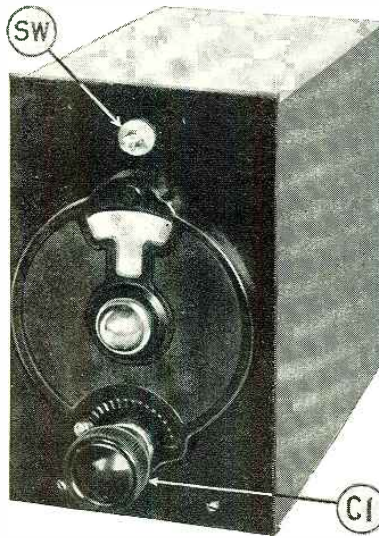

Fig. A. The booster unit, cased in a home-made shield, which prevents interaction with the set itself.

Many other American stations were brought in during the following nights, some of them with magnificent loud-speaker volume, especially WPG. The aerial used for these receptions was about twenty-five feet long and just under thirty feet high. (A word to skeptical fans; this is not stretching the truth, we have seen confirmations of reception from WIOD, WPG, WGY, KDKA, etc.—EDITOR.)

On one point the writer made up his mind from the very start; nothing must be altered in the original Browning-Drake design, so that the booster unit can be added or removed without any internal circuit changes.

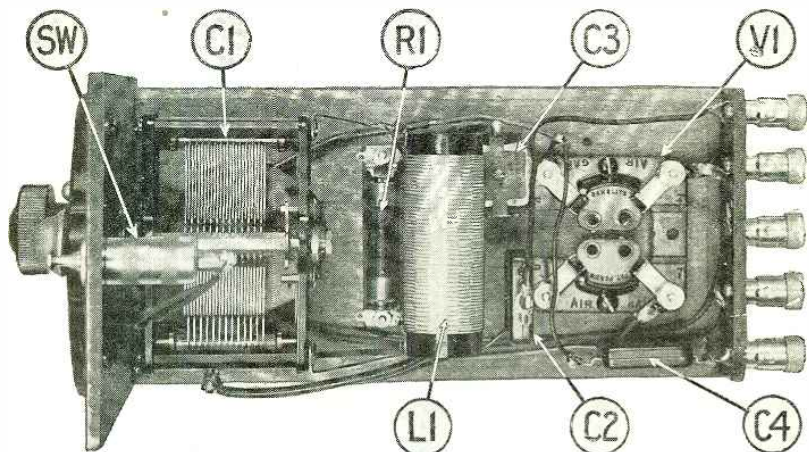

Fig. B. Top view of booster unit with shield removed, showing position of parts on sub-base. The tuning coil is home-made.

### EASY TO ATTACH

The circuit diagram of the complete booster unit is shown in Fig. 1, and from this drawing it may be seen how easily the device may be connected in front of the Browning-Drake, Roberts, or, in fact, any other type of tuned R.F. receiver. One "A" voltage and one "B" voltage are required for the operation of the unit, and these are obtained from the supply devices employed by the receiver, which may be either batteries or socket-power units. In addition to the three "A" and "B" wires, there are only two binding posts which must be connected in order to install the unit; the aerial post which connects with the lead-in, and the output binding post which connects to the aerial binding post of the receiver. The complete apparatus may be connected and placed in operation in five minutes' time.

Another interesting feature of this booster unit is that it may be disconnected easily and quickly. It will be noticed that the switch (SW1), which is shown in dotted lines between the aerial and output binding posts of the unit, connects the aerial directly to the receiver without affecting any of the circuits of the receiver in any way. It is a single-pole, single-throw switch which may be connected externally to the booster unit. Therefore, when this switch (SW1) is open and the battery switch (SW) of the booster unit is closed, the booster is ready for operation. Then, to remove the unit from service (SW1) is closed and the battery switch is opened. Under these conditions the booster tube is turned off and the receiver performs exactly as it would if the booster were not connected, i.e., only the dials in the receiver cabinet require adjustment for tuning. The ease with which the booster may be connected not only permits a saving of current when the unit is not required but simplifies tuning. The desired station may be located on the dials

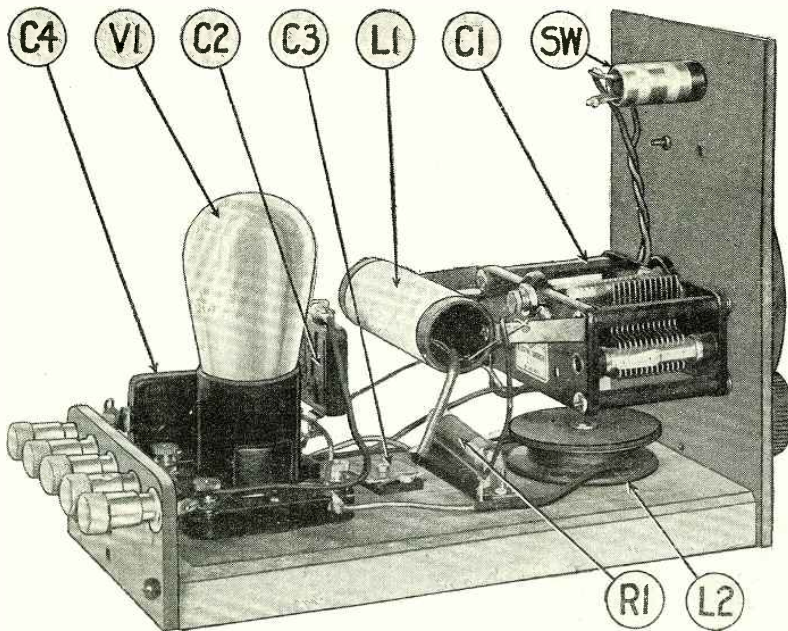

Fig. C. The method of mounting parts is shown clearly in this view of the booster unit. The condensers C2 and C4 are held in place by the wiring.

of the set with the booster unit out of the circuit, and then the booster may be connected for greater sensitivity. This method avoids the necessity of simultaneous adjustment of the three dials when receiving DX.

**CIRCUIT USED**

In circuit design the booster unit is the equivalent of a one-stage R.F. amplifier which is connected ahead of a Browning-Drake type receiver; thus converting the set into a two-stage tuned R.F. receiver with a regenerative detector. The booster circuit is neutralized and, because of this fact, the addition of the booster will not cause unstable operation with a receiver of this type.

In a previous paragraph it was stated that the booster could be connected in front of any standard tuned R.F. receiver, but

the results in all cases are not entirely satisfactory. Without very careful design it is difficult to build a three-stage R.F. receiver which is entirely stable in operation and, because of this fact, the addition of a booster unit to a receiver employing two or more stages of tuned radio-frequency amplification would be apt to cause the R.F. amplifier to oscillate, thus ruining reception. This is not true in all cases, but it frequently happens.

In the schematic wiring diagram (Fig. 1) it will be seen that the antenna circuit is coupled directly with the grid circuit. The aerial is connected with the antenna coil (L1) through a small fixed condenser (C2) having a capacity of .0001-mf., and the ground connection is made through the "A-" wire, which is grounded in the receiver. The antenna coil is tuned with a

.0005-mf. variable condenser (C1) connected in shunt. Also, the antenna coil (L1) is tapped at the midpoint for connection to the neutralizing condenser (C3) which is connected between the center-tap of the antenna coil and the plate of the booster tube (V1).

The plate circuit of the booster unit is of the shunt-feed type; a system in which an R.F. choke coil (L2) is connected between the plate of the tube and the positive terminal of the "B" battery, and the plate circuit is coupled to the next stage through a fixed condenser (C4) having a capacity of .006-mf. With this circuit the plate current reaches the tube by passing through the R.F. choke coil (L2) and the R.F. energy passes through the blocking condenser (C4) in order to go to the grid of the next tube.

In addition to the features of the booster unit already mentioned the only additional point of consideration is the filament control, which is taken care of automatically by a self-adjusting filament-ballast unit. This simplifies the construction of the unit considerably and reduces the number of required controls to one tuning dial and a battery switch.

**REDESIGNING THE UNIT**

The author's model of the booster unit is identical in circuit design with the device pictured in this article. However, as American-made apparatus was not available to him, he used parts of British manufacture. As a description of the original booster would be of little value to most of its readers, RADIO NEWS decided to duplicate the unit as nearly as possible with standard parts. The following paragraphs tell how to construct the device built in RADIO NEWS Laboratories.

A complete list of the parts needed for the construction of the booster unit is as follows:

- One variable condenser, .0005-mf. (C1);
- One mica fixed condenser, .0001-mf. (C2);
- One neutralizing condenser, 2 to 25 mmf. (C3);
- One mica fixed condenser, .006-mf. (C4);
- One aerial coil (homemade) (L1);
- One R.F. choke coil (homemade) (L2);
- One filament-ballast unit, 5-volt, ¼-ampere (R1);

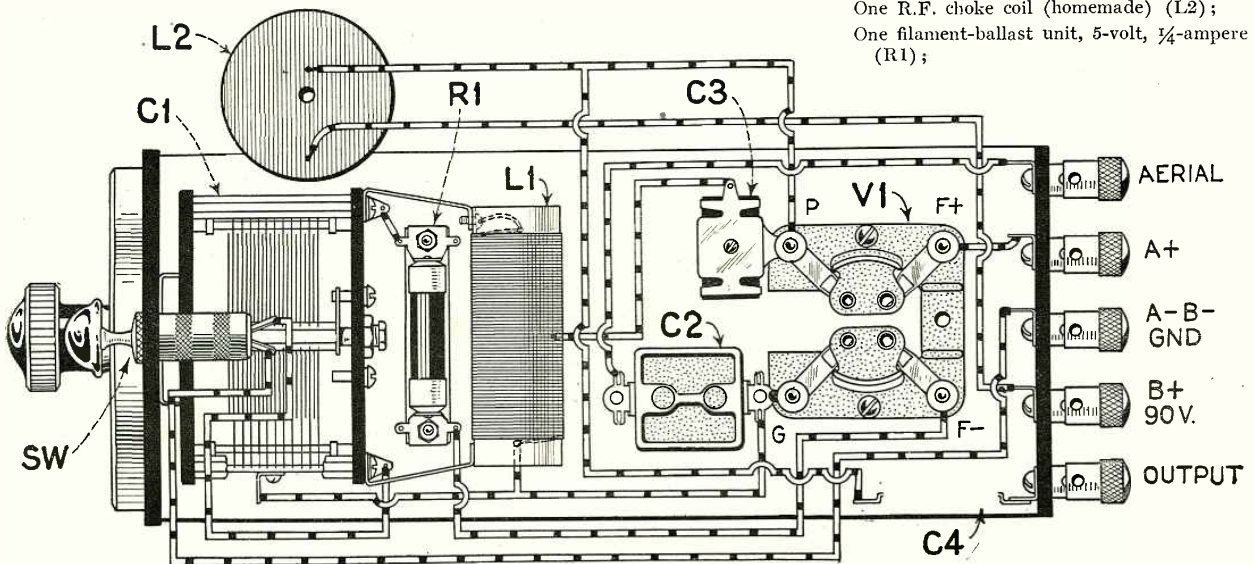

Fig. 2. In this pictorial diagram all connections are shown, though the parts have been shifted slightly for clearness.

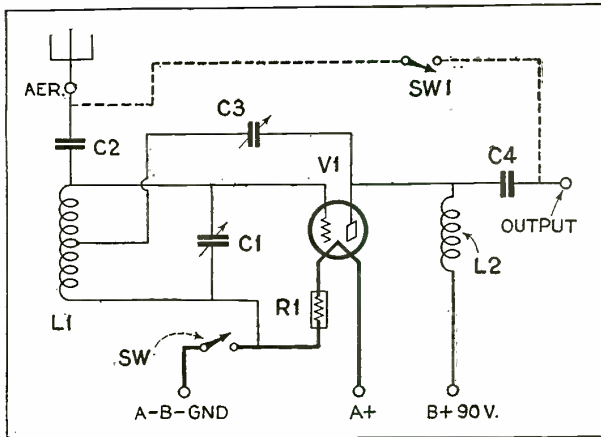

Fig. 1. This is the circuit of the unit as illustrated, with a 201A type tube. The lettering is that of the pictures and list of parts.

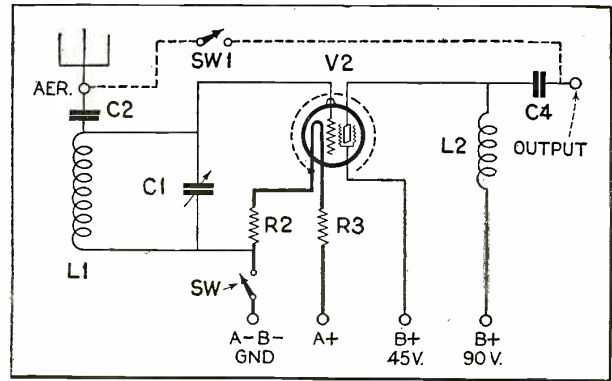

Fig. 6. The use of a screen-grid tube with the modified circuit shown above increases the amplification. For further details, see page 174.

- One battery switch (SW);
- One vacuum tube, 201A type (V1);
- One vernier dial;
- One tube socket, UX type;
- Five binding posts, push type;
- One front panel,  $4\frac{3}{8} \times 7 \times 3/16$  inches;
- One wooden baseboard,  $4\frac{1}{4} \times 8\frac{1}{4} \times 3/4$  inches;
- One binding-post panel,  $2 \times 4\frac{1}{4} \times 3/16$  inches;
- Copper sheet for shielding (See drawings);
- Connecting wire, screws, solder, etc., etc.

COIL DATA

After reading the above list of parts it

**No. 61**

**RADIO NEWS FREE BLUE PRINT ARTICLE**

*Large blueprints with full constructional details and the list of parts used in the booster unit here illustrated will be given or mailed free to anyone asking for them. Write your name and address clearly when applying by letter.*

*Ask for Blueprint No. 61.*

may be seen that the first step of construction should be winding the aerial coil (L1) and the R.F. choke coil (L2); both of these coils may be made easily by the constructor. The aerial coil is wound on a bakelite or cardboard tube 1 inch in diameter and 3 inches in length. The winding consists of 125 turns of No. 30 D.C.C. wire, and a tap is made at the 62nd turn (midpoint) for connection to the neutralizing condenser (C3). The R.F. choke coil is wound on any convenient wooden, bakelite or hard-rubber spool with a core  $\frac{1}{2}$ -inch in diameter; No. 36 S.S.C. or enameled wire is used for the

*(Continued on page 174)*

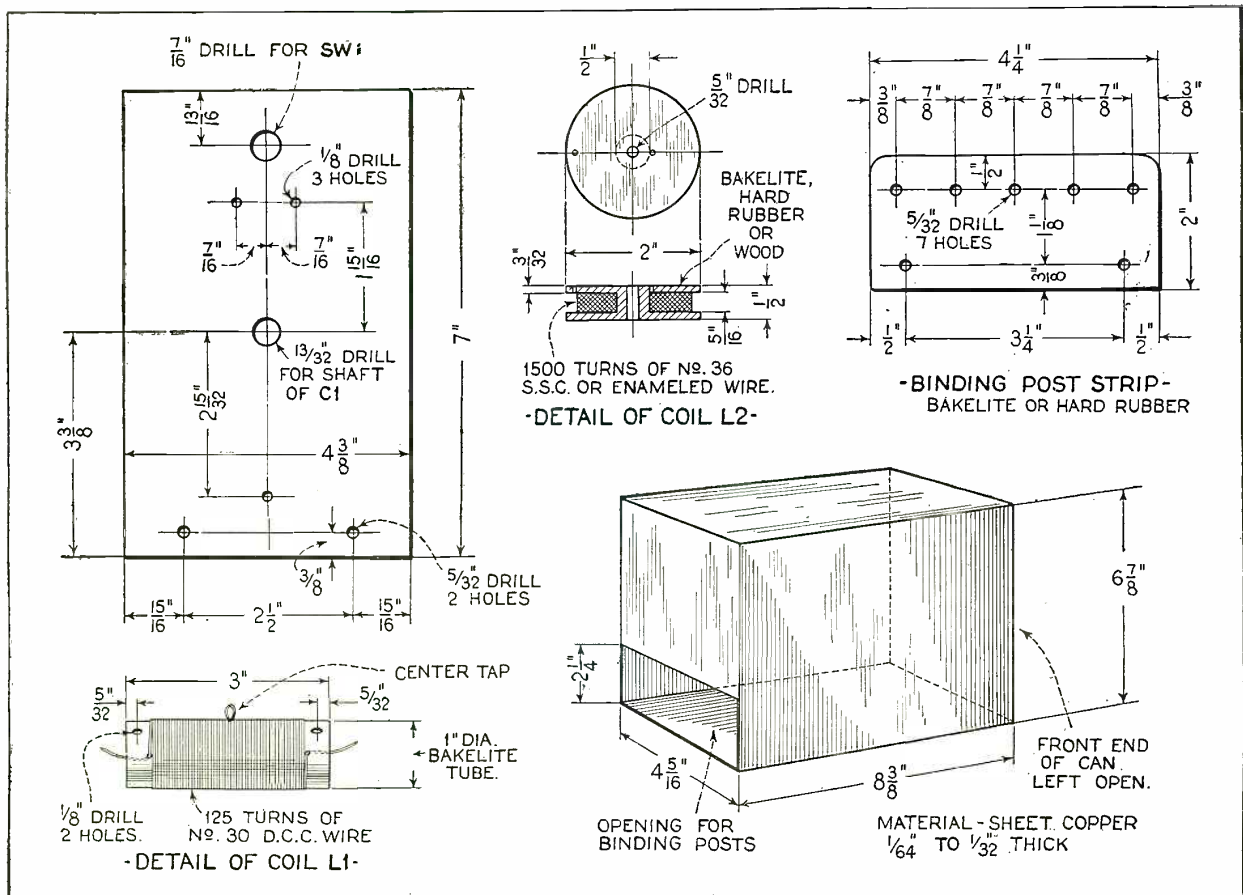

Fig. 4. Complete drilling and winding details for coils and panels, and dimensions of the shield for the booster unit.

# A Screen-Grid Short-Wave Receiver

A Three-Tube Set Employing the 222-Type Tube as an R. F. Amplifier at Ultra-High Frequencies

By Fred H. Canfield

**T**HE screen-grid short-wave receiver described in this article is entirely different from the usual short-wave receiver. Most of the short-wave sets which have been described heretofore in RADIO NEWS have been designed primarily for the experimenter who desires economy and maximum efficiency, rather than ease of control. As a result, the average short-wave set employs only two tubes and is rather complicated in its operation.

In this receiver an attempt has been made to simplify the construction and operation as much as possible, nevertheless retaining a high degree of sensitivity and selectivity. In other words, this set represents an endeavor on the part of the designers to build into a short-wave receiver the desirable characteristics of the usual broadcast receiver.

At this point it should be explained that there is a great difference between the efficiency of a receiver and the sensitivity of a receiver. Every efficient receiver must necessarily be sensitive; but it does not follow that a sensitive set must be efficient. For example, a correctly designed three-tube receiver, employing a regenerative detector and two audio stages, may be both highly efficient and very sensitive; whereas a carefully planned five-tube set, employing two R.F. stages, a non-regenerative detector and two A.F. stages, may be equally as sensitive, but not as efficient—because two extra tubes are required to do the same work.

From the example in the above paragraph it may be seen that high efficiency is not always a necessary, nor even a desirable characteristic; as a five-tube tuned R.F. receiver is much to be preferred over the three-tube regenerative, even though both sets are capable of providing practically the same results. The reason is that, by slightly lowering the efficiency of the tuned



Fig. A. This picture, taken in RADIO NEWS Laboratories while testing the Screen-Grid Short-Wave Receiver, clearly shows the neat, uncluttered appearance of the front panel. The coils for other wavebands are at the left.

R.F. receiver, the set possesses all the desirable features of the regenerative set and in addition becomes much simpler to operate and the circuits are much more stable.

## DESIGN OF THIS SET

The principle of design described above has been applied to this short-wave receiver. In building the set, sensitivity and selectivity were given the first consideration, stability and ease of operation second consideration and, then, the efficiency was made as high as possible. Of course, it would have been possible to increase the efficiency, but this increase would not have been desirable; as it is not needed, and it would complicate the operation of the set considerably. However, notwithstanding these facts, this receiver is more sensitive and produces greater volume than most short-wave sets of other designs.

The average short-wave set consists of

a regenerative detector followed by a stage of A.F. amplification, making a total of two tubes. It is seldom that a short-wave set using more than two tubes is constructed; as the addition of a tuned R.F. amplifier to a receiver of this type might complicate the set to such an extent that the added sensitivity would be of little value. On the other hand, if an untuned R.F. amplifier using a 201A-type tube were connected ahead of the detector, the gain in amplification would be practically negligible. Therefore, up to the present time, the set employing a regenerative detector with a one-stage A.F. amplifier has been considered the best possible combination for short-wave reception.

The screen-grid short-wave receiver has several advantages over the usual regenerative type. It employs a total of three tubes in a circuit consisting of one stage of R.F., a regenerative detector and one stage of A.F. amplification. The R.F. amplifier is of the untuned type and uses the screen-grid (222-type) tube. Therefore, it does not add a tuning control; but it does provide an appreciable gain in amplification, due to the fact that this tube is used. According to James Millen, the designer of the receiver, the amplification of the R.F. stage is between 3 and 4, depending upon the wavelength.

The addition of the R.F. stage has many other desirable effects upon the operation of the receiver. First, it makes the receiver much more stable in operation. Secondly, it prevents the detector tube from radiating energy into the aerial. Thirdly, it makes it possible to calibrate the tuning dial of the set; as the size of the aerial has no effect upon the tuning condenscr. Fourthly, the dead spots (points on the tuning dial where the set cannot be made to oscillate because of aerial characteristics) of the set are eliminated, by virtue of the fact that the aerial is not connected to the detector circuit of the set.

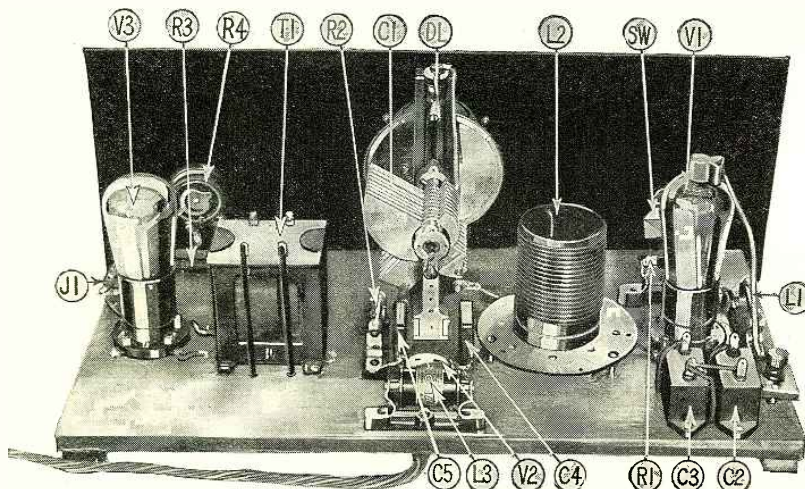

Fig. B. Ample space is available on the baseboard for mounting parts without crowding. This greatly increases the efficiency of the set, especially at the ultra-high frequencies.



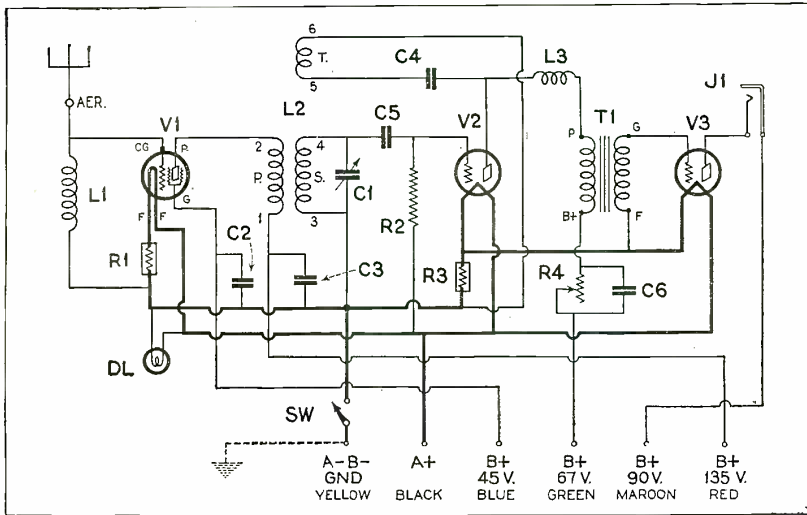

Fig. 1. The symbols used in this complete schematic wiring diagram of the Screen-Grid Short-Wave receiver correspond to those used in the text, list of parts and other illustrations.

The picture shown as Fig. A reveals the simplicity of this receiver as compared with other short-wave sets. In the center of the front panel there is an illuminated vernier dial, and this serves as the only tuning control for the entire receiver. The knob in the lower left corner of the panel controls the battery switch, and that in the lower right corner of the panel the volume-control resistor. These are the only controls; as all rheostats and coupling adjustments were avoided by the designer when building the receiver.

circuit of the screen-grid tube with the grid circuit of the regenerative-detector tube. The coupling between the various windings is fixed; P, the primary winding, is in the plate circuit of the screen-grid tube, S, the secondary winding, is in the grid circuit of the detector tube and T, the tickler winding, is in the plate circuit of the detector tube. The receiver is tuned

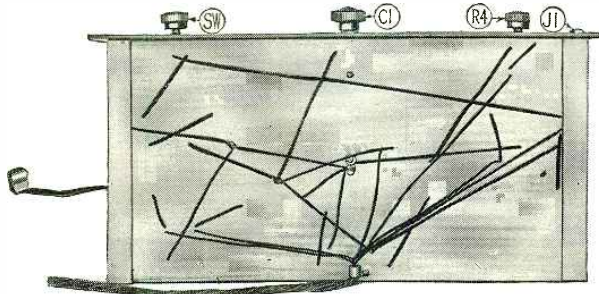

Fig. D. This bottom view of the baseboard shows that the battery leads are attached directly to the parts.

The pictures (Figs. B, C and D) show the simplicity of construction behind the panel and under the baseboard. With the exception of the three instruments mounted on the front panel, all parts of the set are fastened to the wooden baseboard and, in most cases, wood-screws are used for the purpose. Two wooden strips are fastened along the edges of the base on the under side and these make it possible to conceal most of the wiring under the baseboard.

The compactness of the receiver is another important feature. The front panel is 7 x 18 inches and the baseboard measures 9 x 17 inches. The total weight of the set is less than ten pounds.

FEATURES OF THE CIRCUIT

Fig. 1 shows the complete circuit of the receiver. V1 is the screen-grid R.F. amplifier tube, V2 is the detector tube and V3 is the A.F. amplifier tube. It will be noticed that the aerial circuit is untuned, and that an R.F. choke coil (L3), which is connected between the control-grid and the filament of the screen-grid tube V1, serves to couple the aerial circuit to the receiver without the necessity of a tuning control. L2 is a special plug-in R.F. transformer with three windings, which couples the plate

by C1, the variable condenser connected in shunt with the secondary winding. The A.F. circuit of the receiver is standard and employs the usual audio transformer (T1).

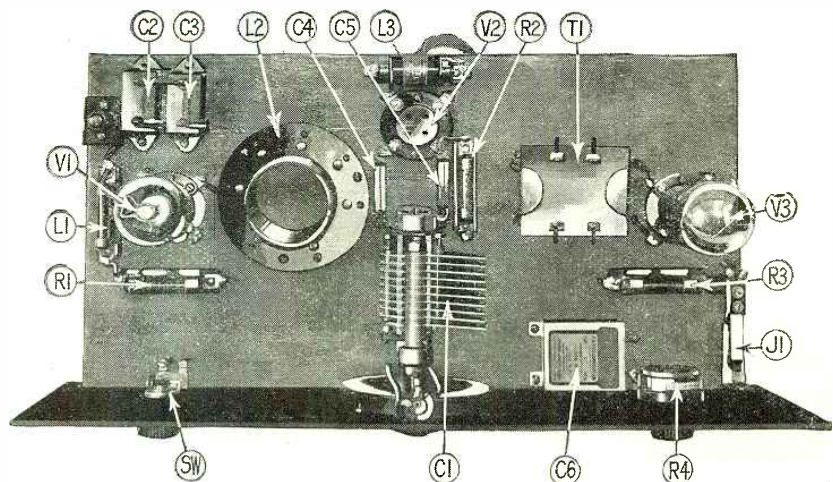

Fig. C. This top view of the receiver shows the exact arrangement of parts; and that on the upper side of the baseboard the wiring, brought through the holes seen in Fig. 1, is visible.

A close examination of the circuit will show that it possesses several unusual features and refinements. Automatic filament-ballast resistors (R1 and R2) are used in place of rheostats for controlling the filament current of the tubes. R1 regulates the filament current of the screen-grid tube and R2 controls that of the detector and A.F. tubes. The volume and regeneration of the receiver is regulated by a variable resistor in the plate circuit of the detector. This resistor (R4) varies the voltage applied to the detector tube, and it is shunted by a 1-mf. by-pass condenser (C6). An R.F. choke coil (L3) is connected between the plate terminal of the detector tube and the primary winding of the transformer, and this prevents R.F. current from entering the A.F. amplifier and also improves the control of regeneration.

PARTS REQUIRED

Another feature of the receiver which has not been mentioned previously is that the use of plug-in coils permits a wavelength range of 15 to 115 meters. Also, another coil may be obtained which permits the reception of stations in the broadcast wave band. Four coils are needed to cover the band of short waves mentioned above and these coils are used in the position of L2 in the circuit. They fit into a special six-contact socket and it is a simple matter to change from one coil to another.

A complete list of the apparatus required for the construction of the receiver is as follows:

- One variable condenser, double-spaced .000-125-mf. (C1);
- Two by-pass condensers, 0.5-mf. (C2 and C3);
- One fixed mica condenser, .001-mf. (C4);
- One fixed mica condenser, .00025-mf. (C5);
- One by-pass condenser, 1-mf. (C6);
- One special R.F. choke coil for antenna coupling (L1);
- One set of four plug-in coils, with socket (L2);
- One R.F. choke coil, short-wave type (L3);
- One filament-ballast unit, 222-type (R1);
- One grid leak, 6-megohm (R2);
- One filament-ballast unit, 112 type (R3);
- One volume-control rheostat, 0-500,000-ohm (R4);
- One A.F. transformer (T1);

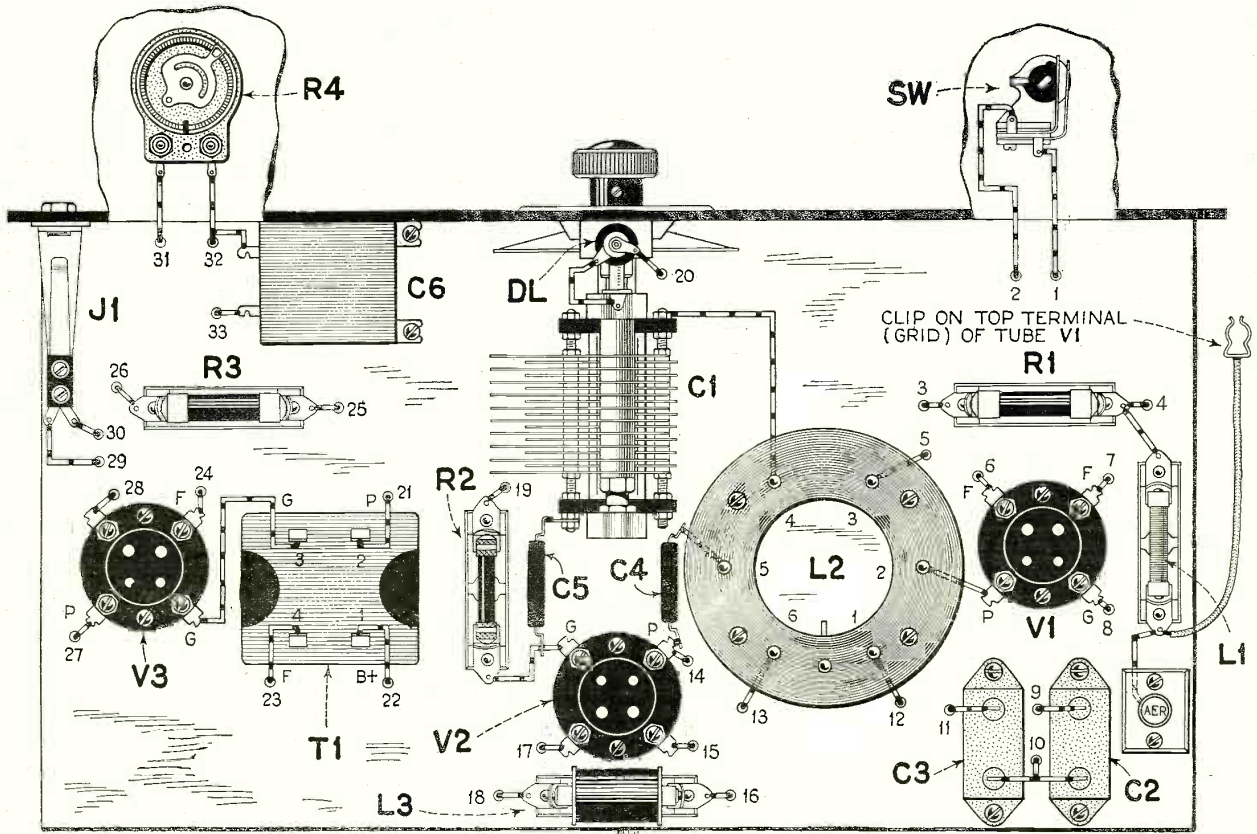

Fig. 3. Layout and upper wiring of the Screen-Grid Short-Wave Receiver.

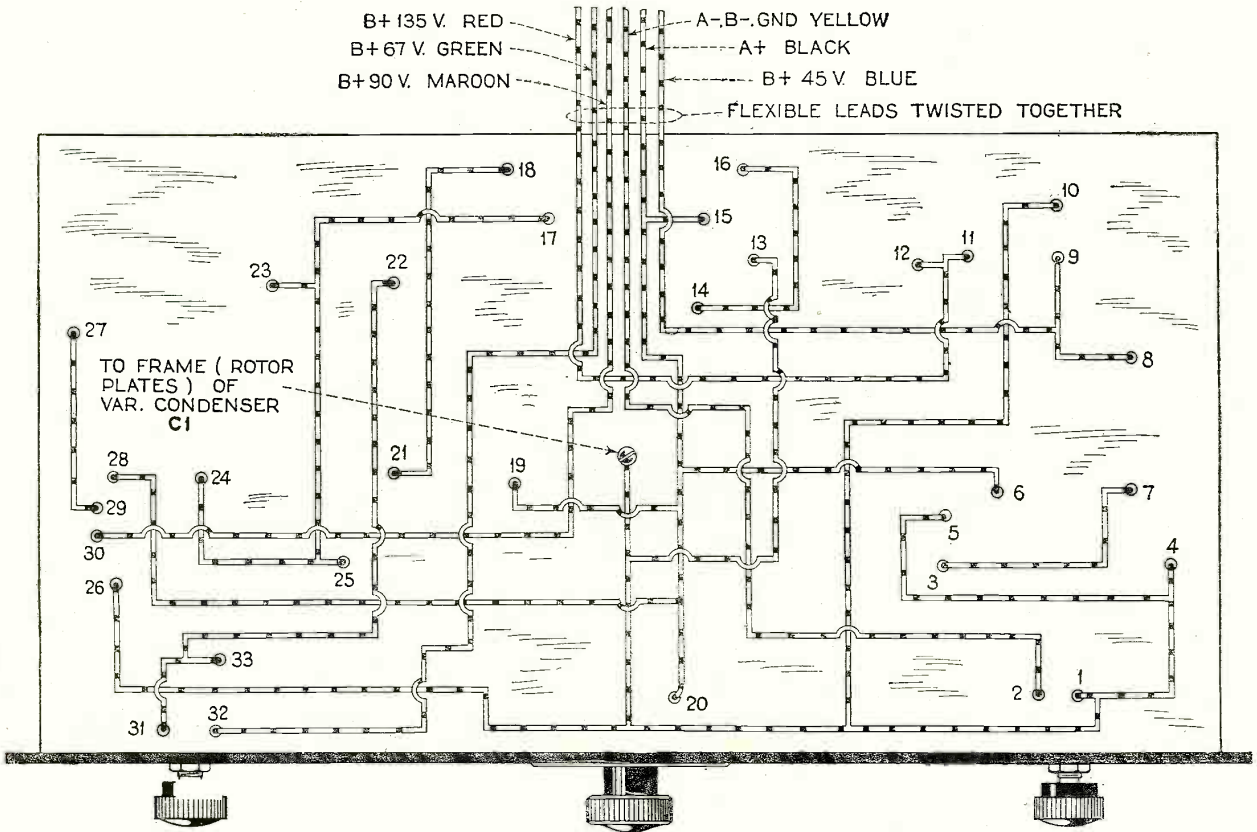

Fig. 4. Wiring below the baseboard. Each hole bears the same number here as in Fig. 3 above.

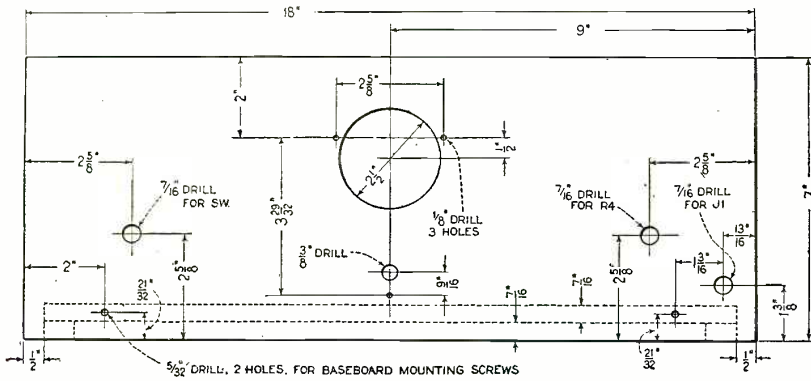

Fig. 5. This drilling layout shows the exact location of all holes required for mounting the various parts on the front panel of this receiver.

- One single-circuit jack (J1);
- One battery switch (SW);
- One vacuum tube, 222-type (V1);
- Two vacuum tubes, 201A-type (V2 and V3);
- Three tube sockets, UX-type;
- Two grid-leak clips for L1 and L3;
- One vernier dial, illuminated type;
- One front panel, 18 x 7 x 3/16 inches;
- One wooden baseboard, 19 x 9 x 1/2 inches;
- One battery cable, 7-wire type;
- One binding post;
- Connecting wire, screws, solder, etc.

Most of the parts mentioned in the above list are standard. However, the two R.F. choke coils require special mention. The R.F. choke coil L1 was especially designed for antenna coupling on short wavelengths, and is the only one of its kind which has ever been brought to the attention of the writer. It fits in a standard grid-leak clip

and has an inductance slightly less than 2 millihenries. It is much easier to buy this piece of apparatus than to attempt its construction; however, the fan who wishes to do so may find it interesting to experiment with coils of various sizes in this position. Also, a resistor might be substituted for the choke coil, but the results would not be quite as satisfactory. In order to determine the size of resistor which will give most satisfactory results, several units of less than 100,000 ohms should be experimented with. The choke coil which is used in the L3 position also fits in a grid-leak mounting, but this is a standard unit, and any short-wave R.F. choke coil may be substituted, if desired.

The tuning condenser specified has a capacity of .000125-mf. and is of the double-spaced type; this condenser is provided with pigtail connections and is of low-loss

design throughout. Therefore, it is ideally suited for short-wave reception, but any efficient condenser of this capacity may be used.

**COILS REQUIRED**

The four short-wave coils illustrated in this receiver are manufactured units; however, home-made coils may be used, if desired. The following directions tell how to build coils which duplicate electrically the ones shown in the illustrations:

Each of the four coils is wound on a piece of bakelite tubing 2 inches in diameter. The smallest coil requires a form 2 3/8 inches long, and this coil has a wavelength range of 15 to 25 meters. The next largest coil, with a wavelength range of 24 to 40 meters, requires a form 2 3/4 inches in length. The two largest coils, with wavelength ranges of 37.5 to 65 meters and

## No. 62

A set of large blue-prints and a list of the parts used in the construction of the Screen-Grid Short-Wave receiver illustrated here will be sent to any applicant. See that your name and address are written or printed legibly. Ask for Blueprint No. 62.

64 to 115 meters, respectively, are wound on forms 3 3/4 inches in length.

Each of the four coils has three separate windings. S, the secondary, is wound with spaced turns of heavy enameled copper wire. P, the primary, consists of turns of fine enameled wire wound between the turns  
(Continued on page 184)

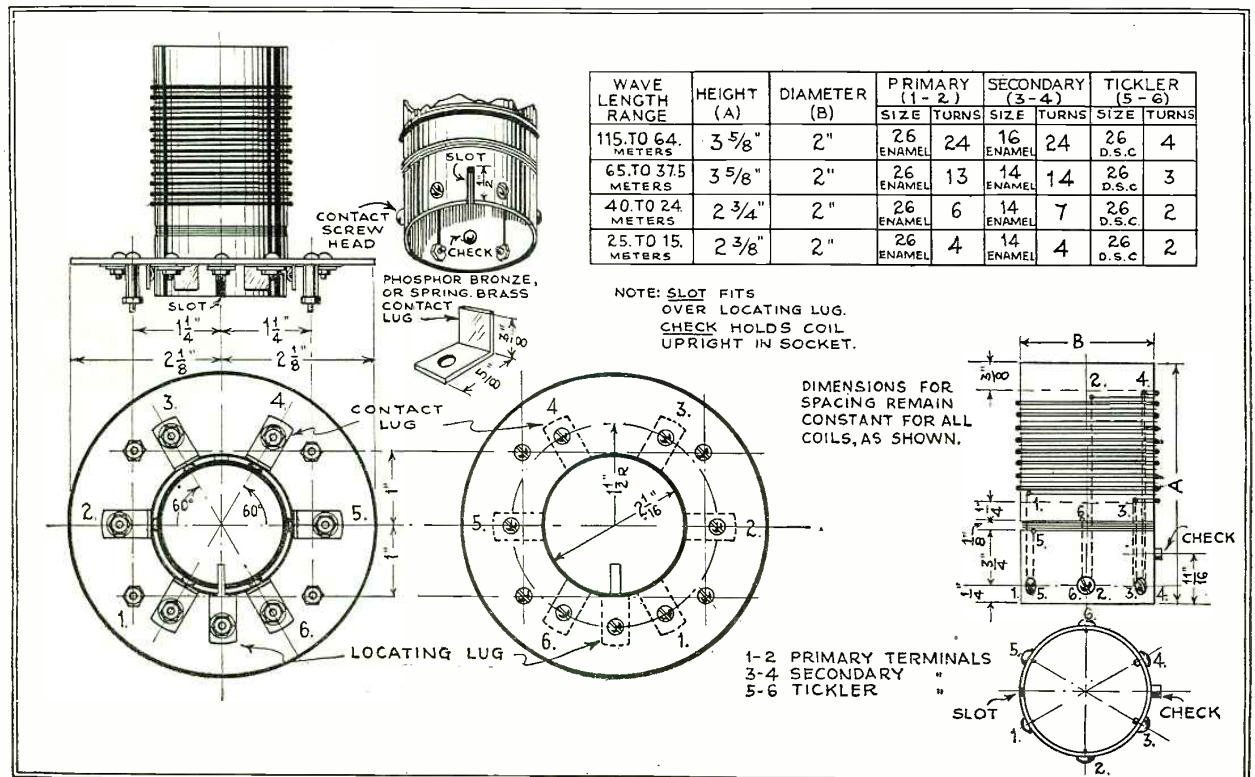

Fig. 2. This diagram gives details for making the four short-wave plug-in coils which are required, in order to cover the waveband of

15 to 115 meters with a 125-mmf. condenser, and also how to make the base receptacle, into which the coils are plugged.

# Better Direct-Coupled A. F. Amplifiers



Recent Results Obtained by Loftin and White from Experiments Directed to the Elimination of Distortion from Radio Reproduction

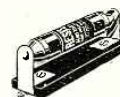

FEW radio fans are aware of the fact that there is a system of audio-frequency amplification which renders *theoretically distortionless reproduction*. It is true that amplifiers of this type are not common in broadcast receivers, but frequently they are used in laboratories by engineers when making precision measurements. It is possible to construct such a device with modern apparatus, the principles having been known to the radio world for years.

The type of apparatus referred to in the above paragraph is the direct-coupled amplifier. In circuit arrangement it is very simple; but in its usual form it has a number of very undesirable features which make it unsuited for use in the average receiver. It is rather difficult to adjust, and it is very large in size, due to the number of batteries which are required for its operation. However, it possesses one feature which is not found in other types of amplifiers; namely, when operated properly it does not cause appreciable distortion, and this feature makes it invaluable to engineers.

Recently there was announced a very interesting electrical development which may be applied to direct-coupled amplifiers. This development is a result of the research work of Edward H. Loftin and S. Young White, well-known for the now famous Loftin-White R.F. circuit. Their A.F. amplifier system provides a direct-coupled amplifier with its desirable features retained and its undesirable characteristics either eliminated or modified so that they no longer present a problem. Therefore, it is now practical for the broadcast listener to enjoy the performance of a direct-coupled amplifier.

### WHAT IS "DISTORTION?"

Before continuing further with this discussion, it is necessary to explain the meaning of the word *distortion*. In modern ra-

dio literature this word is used very freely, and the term *distortionless amplification* often is applied to the reproduction obtainable from any high-quality amplifier. However, it is probably safe to say that there is not a broadcast receiver in use today, outside a laboratory, which does not cause a measurable amount of distortion. Also,

amplifier practically all the causes of distortion have been removed. With man-made apparatus and adjustments, it is questionable whether distortion is ever completely eliminated, but, nevertheless, it may be reduced to such a low value that it is beyond detection by the human ear.

A comparison of the circuit diagrams of the various types of amplifiers in use shows clearly why all types of amplifiers, with the exception of the direct-coupled type, must cause some distortion, theoretically at least, Fig. 1 shows the essential circuits of three popular types of amplifiers, and Fig. 2 shows the simplified circuit of a direct-coupled amplifier. In Fig. 1, A is the circuit of a standard transformer-coupled amplifier, B is the circuit of a resistance-capacity-coupled amplifier and C is the circuit of an impedance-capacity-coupled amplifier. In each case, it will be noticed, some piece of apparatus is used to isolate the grid of the second tube from the plate battery of the first tube; and it is this apparatus which introduces the distortion. In A an audio-frequency transformer is used for the purpose; but it is a well-known fact that transformers do not respond uniformly at all audio frequencies. In B and C a fixed condenser (C) is employed; as this performs better on the high frequencies than on the low, it may be said to cause uneven amplification.

In Fig. 2 it will be seen that, in the direct-coupled amplifier, a battery is used to couple the plate and grid circuits of the two tubes. As a battery has practically no unfavorable frequency-response characteristics, this arrangement eliminates the main cause of amplifier distortion.

A complete theoretical description of the improved direct-coupled amplifier previously mentioned, was presented at a recent meeting of the Radio Club of America in a paper read by the inventors, Loftin and White. The following paragraphs contain the more pertinent parts of the paper from which they are quoted.

### PROBLEMS OF DIRECT COUPLING

The discussion embraces some practical considerations in the design of direct-coupled, three-electrode, vacuum-tube systems for audio amplification and detection with amplification to take advantage of the possibilities in such systems for overcoming limitations inherent in the several other systems of audio amplification with and without detection.

Audio-amplifying systems other than the direct-coupled type have undesirable frequency-characteristics, due to the reactances and connections used to isolate each grid from the high potential of the preceding plate circuit. The absence of such reactances in the direct-coupled system, and other advantageous features, would have led to its general adoption long ago, had it not been for certain heretofore-uncured peculiarities and economical drawbacks, briefly outlined in connection with Fig. 2.

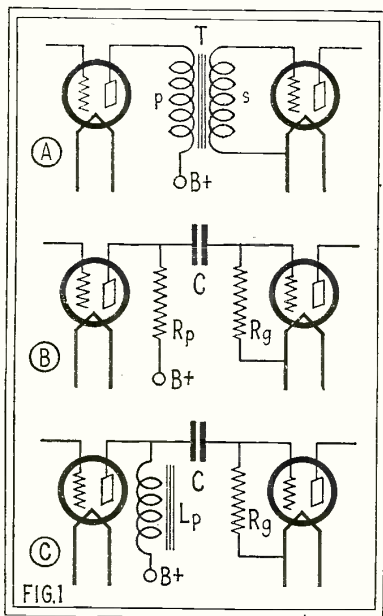

Essential circuits of three popular types of A.F. systems. A, transformer coupling; B, resistance-capacity coupling; C, impedance-capacity coupling.

even in the best broadcast stations the transmission is distorted to some extent before the programs are placed "on the air."

On the other hand, in the direct-coupled

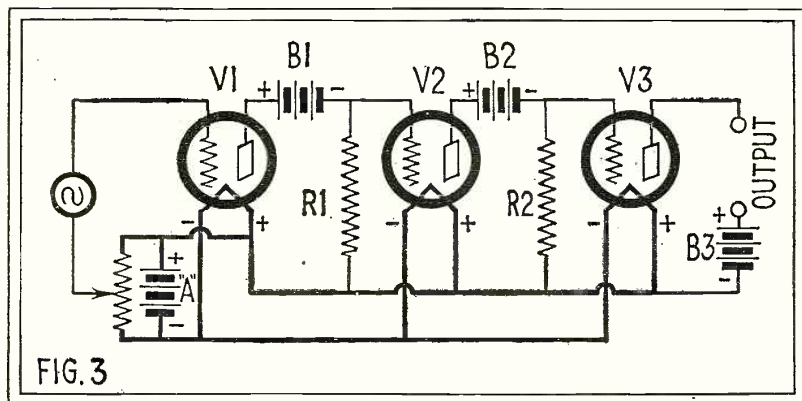
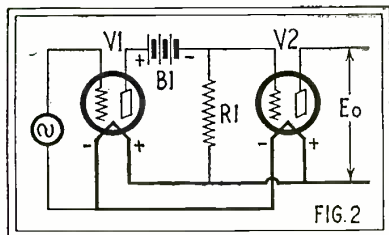

FIG. 3

This diagram illustrates the first steps taken by Loftin and White to bring into practical form the desirable characteristics of direct-coupled A.F. amplifiers. Except for the necessity of manual adjustment of the grid-bias potentiometer the circuit is very satisfactory.

This figure shows a simple system of two tubes, directly coupled through a battery B1, having a good frequency-characteristic of amplification, but a goodly share of the peculiarities and drawbacks heretofore experienced with such systems. Prior to our work, rather high voltages were usual; thus



Here a battery replaces the usual coupling device, which is the greatest cause of distortion in most amplifiers.

requiring undesirably large and expensive blocks of batteries for each stage, a drawback from both the economical and the weight-and-space standpoints.

Tubes of the same type and make vary considerably in filament-to-plate resistance and, since Fig. 2 shows clearly that the filament-to-plate resistance of tube V1 determines in large measure the biasing effect of battery B1 on the grid of tube V2, we can state with assurance that an adjustment for a given tube in the position of V1 which gives the cor-

Most efficient grid-bias regulation is obtained when the filament current of the 199-type tube V4 (see also Fig. 4) is 34 milliamperes. If the plate current of V3 is less than this value, the potentiometer R1 should be used to correct the condition.

rect operation of tube V2 may be so far wrong with a different tube in the position V1 as to saturate or block tube V2; a peculiarity affecting satisfactory operation to an undesirable degree.

Another difficulty in the system as shown in Fig. 2 is the effect of a high-frequency carrier-current impressed on the grid of tube V1, as must be done when the system is used as a combined detector-amplifier. Because of the normal rectifying properties of the tube, the high-frequency carrier-current changes the filament-to-plate resistance in proportion to the strength of the carrier or incoming signal; so that battery B1 alters the grid bias of V2 in proportion to the strength of the signal, thus altering the point of operation on the plate-current characteristic curve of tube V2; so much so for strong signals that the plate current of V2 may be blocked. This feature restricts the system of Fig. 2, if unmodified, for use as an audio amplifier; if employed for radio reception, it must be preceded by the usual detector system and some form of audio-reactive coupling, which arrangement would introduce in the input portion of the system precisely those undesirable frequency effects of other systems which we have avoided by our modified direct-coupled system.

VOLTAGES REQUIRED

Fig. 3 is used to point out the fundamental steps by which we proceed to bring into practical form the good points of the direct-coupled system. Using, for example, a 171-type tube at V3 in the output circuit of a three-tube system, we find that the potential of battery B2 must be of such value as to bring the plate current of V3 to below 5 milliamperes with the normal 180 volts of plate potential at B3; which voltage may be derived from a "B"-socket-power unit. Therefore, the potential of B2 is about 50% in excess of the normal grid bias of the tube being used, or about 67 volts for the 171-type tube, which normally requires 45 volts grid bias.

The resistance of R2 may be several megohms to keep at a low value the current drawn from B2. If the current is not allowed to exceed 50 microamperes, the commercial types of dry "B" batteries will have substantially "shelf-life" in this use. (See page 135 of this issue.)

The potential of battery B1 need not exceed 4½ volts. The resistance of R1 may be of the order of 1 megohm. Both R1 and R2 are connected to the positive side of the filament system. A potentiometer across the "A" battery is shown connected in the grid circuit of tube V1 for controlling the negative grid bias for this tube. Tubes

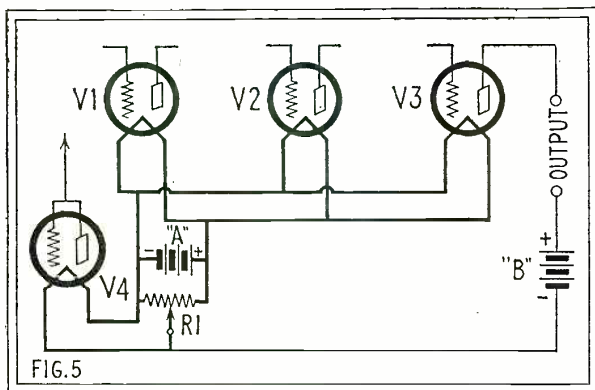

V1 and V2 should be of the high-mu type and the higher the mu, the better. We have

worked almost exclusively with the 240-type tubes in these positions, there being no higher mu tubes commercially available.

GRID-BIAS REGULATION

Except for the necessity for manual control of the grid-bias potentiometer to keep power tube V3 operating at the middle of the linear portion of the plate-current characteristic curve with different strengths of incoming signal carriers, the system of Fig. 3 is a practical and satisfactory combined detector-amplifier system. The normal use of the 171-type tube requires a 45-volt grid-biasing battery, and the potential of battery B2 is but slightly in excess of this normal requirement. All of the batteries have extremely small current drain, and can therefore be ordinary small dry-cell "B" and "C" batteries.

The potentiometer permits altering the grid bias of the first high-mu tube (V1) to alter the plate-to-filament resistance until the plate-current biases V2 in the right degree to cause in turn the right bias on the output tube to bring its operation at the correct point on its plate-current characteristic curve for any strength of signal carrier impressed upon the input of V1. A carrier of the order of several volts is sufficient to run the plate current of the last tube up to saturation. Adding negative grid bias to V1 will bring this excessive current down to the desired operating region. Also, if tubes in positions V1 or V2 are exchanged for others having different filament-to-plate resistances, the potentiometer can compensate for any difference in the adjustment of the system.

While potentiometer regulation is satisfactory to the skilled operator or for the laboratory, it does not constitute a desirable arrangement for popular types of commercial receivers. Here an automatic or self-regulating effect is desirable to the point of being essential, and fortunately the result can be had both simply and effectively.

AUTOMATIC ADJUSTMENT

Since the output or power tube is the sufferer from the carrier-current effect and, at the same time, has sufficient energy with which to do considerable work, it is only reasonable that it should be called upon for

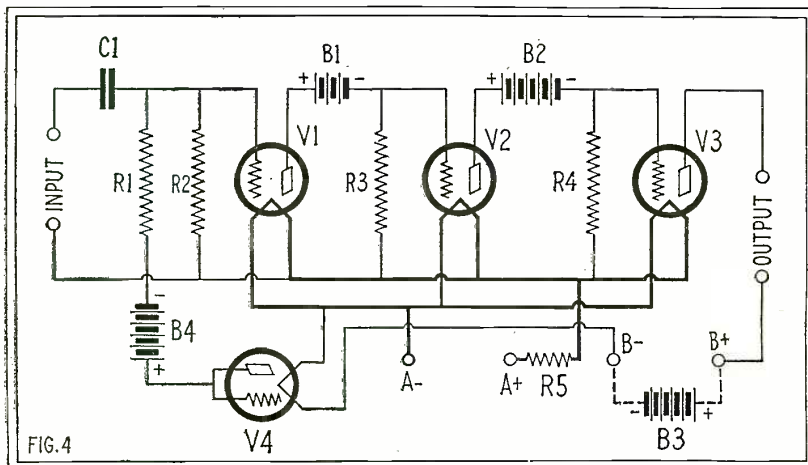

An entirely practical direct-coupled amplifier circuit in which the 199-type tube V4 automatically regulates the grid bias. V1 and V2, 240-type tubes; V3, 171-type tube; R1, 0.25 meg.; R2, 2 meg.; R3, 0.75 meg.; R4, 4 meg.; R5, 1 ohm; B1, 4.5 volts; B2, 67 volts; B3, 180 volts; B4, 22 volts; and C1, .002- to .006-mf.

aid. Quite a large negative bias on the first tube is required to overcome the biasing effect of a strong carrier; but the large plate current of the output tube is ideally adapted to aid in bringing about this compensating bias. However, this output-tube plate current must not be so used as to introduce an undesirable feed-back effect, either in the matter of desired signal currents or hum currents if a "B"-socket-power unit is used.

The arrangement shown in Fig. 4 is a most satisfactory solution of the desirable self-regulating feature, and seems to owe its success to the filament characteristics of the 199-type of tube used in position V4. The grid and plate electrodes of this tube are tied together to make it in effect a two-electrode tube. The filament is connected in series with the plate circuit of output tube V3, so that the filament is heated by the plate current. Battery B4 is connected in series with the filament-to-plate (and grid) path of V4 in order to bias, with the aid of resistances R1 and R2, the grid of V1 negatively. Obviously, the lower the filament-to-plate resistance of V4, the greater will be the negative biasing effect of B4 on V1; and, since this filament-to-plate resistance decreases with the increase of the temperature of the filament, and may vary between almost infinite value with a cold filament and a comparatively low value with a very hot filament, the desired self-regulation is possible by having the plate current of the output tube control the heating of the filament of V4.

The tube-space resistance varies inversely as the square of the filament current, and consequently changes greatly with small changes in plate current of the output tube. Therefore, carrier waves, or discrepancies in tube impedances, can be nicely compensated for, and the plate current of the output tube remains very close to its rated value.

Although, for general normal operation, the filament of the 199-type of tube operates at quite a high temperature, it effectively

operates in the system of Fig. 4 at such low temperature that its thermal inertia is sufficiently high not to follow even the lowest audio frequencies; as a result, we find no evidences of signal and hum-current feed-back whatsoever.

The over-all sensitivity of the system is excellent. The effect commonly known as detector overloading is not present even up to 20 volts of radio-frequency input; despite the fact that the first tube has only four volts of plate potential. Because of this low plate voltage, microphonic effects are not possible, and therefore acoustical feed-back howling is never encountered. Regenerative oscillation cannot take place.

VALUES OF RESISTORS

The types of tubes and values of electrical elements for a practical assembly of

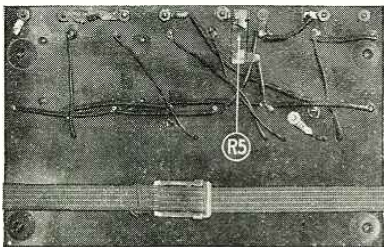

View of the wiring under the baseboard in Mr. White's direct-coupled amplifier, shown also below. R5 is a 1-ohm filament-ballast resistor.

the system of Fig. 4 are listed in the caption beneath this diagram. In assembling this apparatus, great care should be taken to keep distributed capacities low; because high frequency persists throughout the system and an excess of distributed capacity will attenuate the energy to an undesirable degree. The values of the resistors should be held within 10% of those given, which is a feature requiring special attention. The resistors are of high order. Heretofore there has been no need for particular accu-

racy in commercial high-value resistors, with the result that the actual values of purchased resistors may differ as much as 100% from the markings. Also, the actual values of resistance may vary widely with different current values through the devices. The resistors used should be measured in a way employing only a few microamperes of measuring current, as they are so used in the system.

The 199-type tube operates best for the purpose of regulation with a filament current of about 34 milliamperes. If the plate-supply current differs from this optimum current value, compensation is readily had by an arrangement shown in Fig. 5.

In this figure a high-resistance potentiometer (R1) is connected across the filament-supply system, with the slides so connected around the filament that adjustment permits of supplying additional heating current from the "A" battery if not enough plate current is available, and shunting away a portion of the plate current if it exceeds the desired amount.

ANOTHER ARRANGEMENT

Fig. 6 shows an interesting extension of the system, recommended potential and electrical constant values being as given in the caption. In this arrangement the 199-type tube, V4, is used in the dual capacity of regulator and input (detector) tube, being used as a three-electrode tube in the latter capacity. This arrangement is capable of a sensitivity considerably in excess of the ordinary grid-leak detector and two-stage, transformer-coupled audio system; probably a bit too much amplification for ordinary uses, but it is an easy matter to reduce the amplification to any desired degree.

In the arrangement of Fig. 6, the amount of plate current flowing through the filament of V4 determines the bias of battery B1 on tube V1 as before, and thus regulates the plate current of V3. Carrier-currents impressed upon the grid circuit of V4 have the previously-discussed tendency to change the initial bias of the system; so that regulation is still desirable. In this arrangement the filament current of the 199-type tube may range from 36 to 40 milliamperes, the average of 38 being preferable. Increasing the potential of battery B1 above the 9 volts indicated tends to bring in microphonic effects, which, with the aid of the very large amplification, may give acoustical feed-back howling. Because of the extreme sensitivity of the system, however, it is not necessary to go beyond this potential. In this modified arrangement the values of the resistors are not nearly so critical as in that of Fig. 4, and may differ from those given by as much as 100% or more.

If the grid circuit of V4 is connected to one side or the other of the filament system, the resistance of the filament acts as a feed-back element because of the plate current flowing there and, with the high amplification, considerable distortion may result. It is possible to overcome this in large measure by using a choke-and-condenser coupling (LC) to the loud speaker, as shown, to shunt and block out signal currents from the filament of V4. To make the system applicable to all forms of loud-speaker coupling, it is desirable to connect a fixed resistor R4 of about 1,000 ohms across the filament and connect the grid circuit to about the center of this resistance.

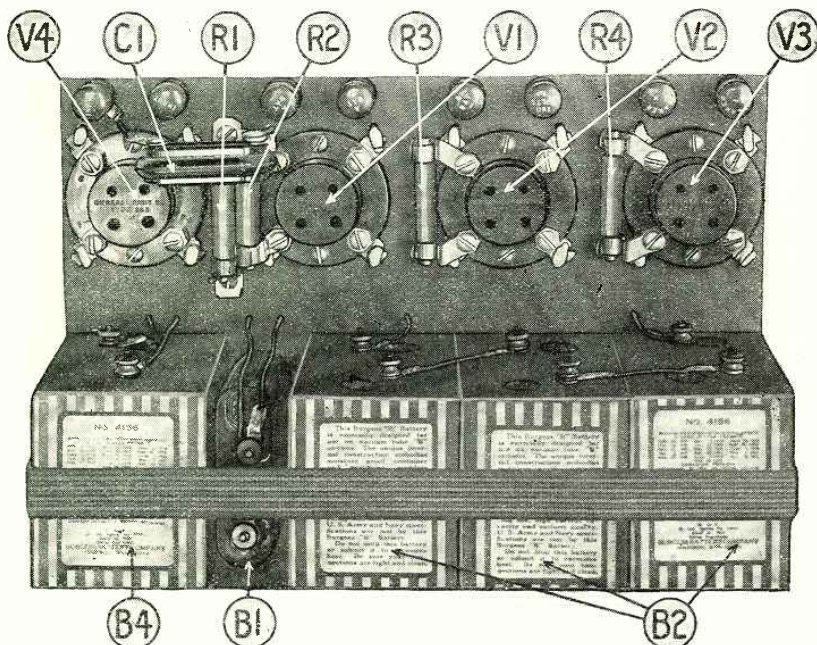

This direct-coupled amplifier, constructed by S. Young White, uses the circuit shown in Fig. 4. The parts have the same values as those specified in the caption of that illustration.

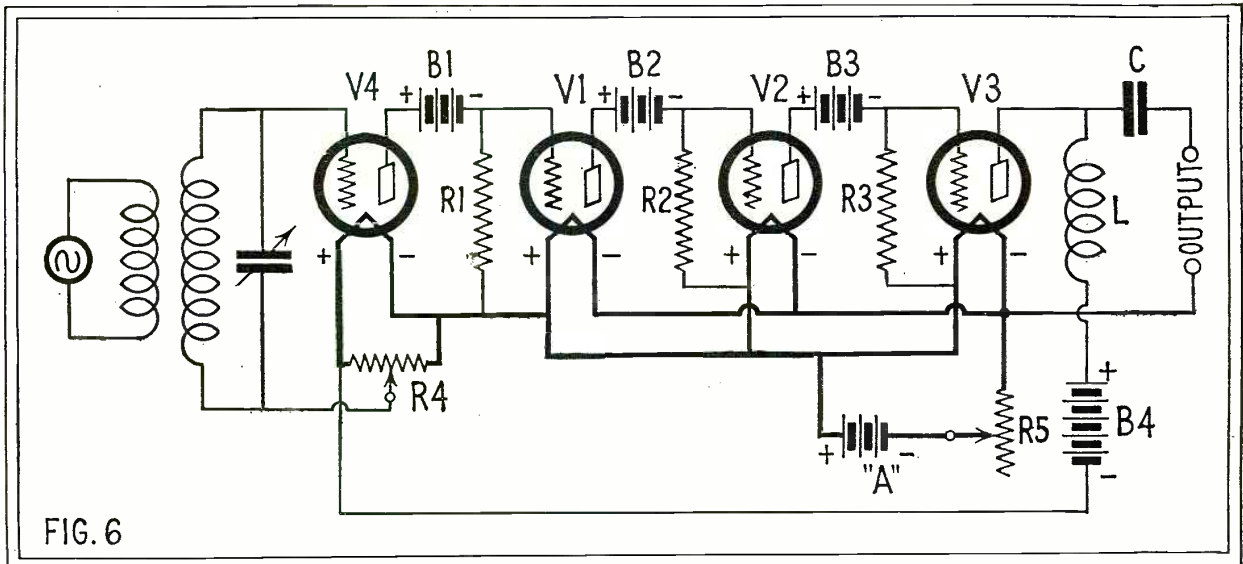

FIG. 6  
 In this direct-coupled amplifier circuit the 199-type tube V4 is used in the double capacity of grid-bias regulator and input (detector) tube. V1 and V2, 240-type tubes; V3, 171-type tube; R1 and R2, 2 meg.; R3, 4 meg.; R4, 1,000-ohm potentiometer; R5, filament rheostat; B1, 9 volts; B2, 22.5 volts; B3, 67 volts; B4, 180 volts; "A," 6 volts; L and C, output filter. It is very sensitive.

PHONOGRAPH APPLICATIONS

Any of the systems can be used as phonograph pick-up and other audio amplifiers, as well as detector-amplifiers for radio. The arrangement of Fig. 6 is a bit too sensitive for phonograph work; though in a combined radio and phonograph system the pick-up can be connected across the input of tube V1. The system of Fig. 6 has the further effect of acting as a signal-

limiting arrangement. If an excessive signal is encountered, it will not reproduce the signal in proportion to the input strength beyond a certain point, but will distort sufficiently to indicate that operation of the input volume control is needed.

The systems have been operated most satisfactorily with alternating-current supply throughout, using high-mu heater-type tubes. Since commercial high-mu alternating-current tubes are not available at the

present time, it does not seem opportune to go into this phase of operation; though it may be remarked that there are features of the system, co-related to the non-microphonic feature, which tend to lessen hum difficulties arising in other systems. Considering the high amplification of the systems at 60 cycles, the small hum encountered in work so far carried on has been most gratifying.

# The Capacity of a Condenser Combination Arrangement

By Leslie R. Jones

EVERY experimenter has around his workbench an assortment of condensers, both fixed and variable, which may oftentimes be utilized to advantage.

Many times during the process of experimenting, condensers of odd capacities may be required and, as a rule, a simple combination of one or more of these "extras," either in series or in parallel, will save the expense of new ones.

Also, as their use is usually but temporary, that is, only for an experimental test, this saving and convenience is worth while.

Condensers having capacities such as .0001, .00025, .0005, .001, .002, .005, .006-microfarad, are those used in standard hook-ups and, when special values are needed, these may easily be "built up" by combining those on hand according to the reference table on condenser combinations given here.

The formulas for working out these combinations are not difficult, but oftentimes our work will not permit enough time to be used for this calculation. Hence this reference table which gives readily, at a glance, the desired combinations needed. For any odd combinations not included here, this formula will be useful to compute the resultant capacity of any combination of series condensers:

$$\frac{1}{C} = \frac{1}{C_1} + \frac{1}{C_2} + \frac{1}{C_3} + \frac{1}{C_4} \dots$$

Where C = equivalent capacity of the combination, and C<sub>1</sub>, C<sub>2</sub>, C<sub>3</sub>, C<sub>4</sub> = the respective capacities of each of the series condensers. Obviously, if all the condensers are of the same capacity, the capacity of one divided by the number used gives the effective result in series connection.

On the other hand, for each parallel

arrangement, the capacities of each are simply added together, giving the resultant capacity.

$$C = C_1 + C_2 + C_3 + C_4 \dots$$

The following table shows the resultant of two capacities in both series and parallel arrangements.

Condenser capacities in microfarads	Resultant capacity (mf.)		Condenser capacities in microfarads	Resultant capacity (mf.)	
	Series	Parallel		Series	Parallel
.0001 and .00025	.000071	.00035	.0005 and .001	.00033	.0015
.0001 " .0005	.000083	.0006	.0005 " .002	.0004	.0025
.0001 " .001	.000090	.0011	.0005 " .005	.00045	.0055
.0001 " .002	.000095	.0021	.0005 " .006	.00046	.0065
.0001 " .005	.000098	.0051	.001 " .002	.00066	.003
.0001 " .006	.000098	.0061	.001 " .005	.00083	.006
.00025 " .0005	.00016	.00075	.001 " .006	.00085	.007
.00025 " .001	.0002	.00125	.002 " .005	.0014	.007
.00025 " .002	.00022	.00225	.002 " .006	.0015	.008
.00025 " .005	.00023	.00525	.005 " .006	.0027	.011
.00025 " .006	.00024	.00625			

The tables below give the resultant capacity for one, two, three and four con-

densers of the same capacity, in series and in parallel.

Capacity	2 condensers in:		3 condensers in:		4 condensers in:	
	Series	Parallel	Series	Parallel	Series	Parallel
.0001	.00005	.0002	.000033	.0003	.000025	.0004
.00025	.000125	.0005	.000083	.00075	.000062	.001
.0005	.00025	.001	.00016	.0015	.00012	.002
.001	.0005	.002	.00033	.003	.00025	.004
.002	.001	.004	.00066	.006	.0005	.008
.005	.0025	.010	.0016	.015	.00125	.020
.006	.003	.012	.002	.018	.0015	.024

# Radio Wrinkles

## Cutting In or Out the Last Audio Stage

THE above diagram presents a circuit for switching from one to two stages (or from two to three) of audio amplification, which may be applied to any standard receiver. A four-pole, double-throw jack switch is employed for the purpose, and every desired change, including that of controlling the filament of the last-stage tube, is accomplished with one movement.

A glance at the circuit diagram will show that the amplifier used to illustrate the switching system employs a standard two-stage, transformer-coupled A.F. circuit with a power tube and an output filter in the last stage. Rheostats are employed for adjusting the filament current of each tube; but this is not an essential part of the circuit, as filament-ballast units could be substituted without affecting the results.

When the switch is set in the lower position (No. 2), only one stage of amplification is connected. It will be noticed that the switch disconnects the primary of the second transformer, and connects the loud speaker in the plate circuit of the first tube. Also, the switch opens the filament circuit of the power tube, thus saving battery current when the last stage is not being used.

When set in the upper position (No. 1), the switch connects the last stage of amplification with the loud speaker. To do this, it performs three operations: first, it con-

nects the primary of the second transformer in the plate circuit of the first tube; second, it connects the filament of the power tube with the battery, and third, it disconnects the loud speaker from the first tube, and connects it to the output filter.

The use of a jack switch to control the operation of an audio amplifier has several advantages over the use of jacks, which is the most common method. When a switch is used, the loud speaker may be permanently connected to binding posts, and it is not necessary to change a plug from one jack to the next. Also, with a switch, the wiring is no more complicated, yet the mechanical arrangement is much more compact. Lastly, it is possible to change from one to two stages of amplification, or vice versa, much more easily and quickly; as it is necessary only to turn a knob mounted on the front panel of the receiver.

—Coleman Sutton.

## A Compact, Quickly-Erected Aerial for Tourists

AN excellent aerial for portable use is illustrated in the accompanying diagram. It is very compact to carry, yet it is an entirely practical arrangement. It may be erected almost anywhere in a very few minutes' time, and its length may be varied as desired.

The illustration shows that a fishing rod of standard design is used as a mast for the aerial, and that the aerial wire is coiled up on a fishing reel when not in use. The support for the other end of the aerial is provided by a hook, fastened to the end of

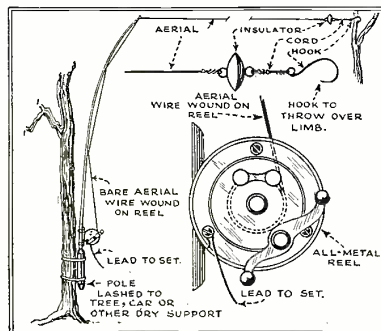

A stout fishing rod, a reel, copper wire and insulator are the essential parts of a simple portable aerial which is ideal for camping and automobile trips.

the wire. When erecting the aerial this hook may easily be caught over a projecting limb of a tree.

The parts required for this portable antenna are as follows:

- One wooden, jointed fishing rod of good length;
- One all-metal fishing reel;
- One hundred feet of No. 20 bare-copper wire;
- One aerial insulator;
- One wire hook;
- Cord to fasten hook and insulator, and to mount mast.

The fishing rod must be of wooden construction because it is used as an insulator at the lead-in end of the aerial. It should be, preferably, of the type used for salt-water fishing, as these rods are much stronger than the fresh-water type. An all-metal fishing reel is specified because contact is made to the frame of the reel, by the wire which connects the aerial with the receiver. If a wooden reel were used, it would be more difficult to connect the aerial with the set.

In preparing this aerial for use, the first step is to solder one end of the No. 20 bare-copper aerial wire to the spool of the fishing reel. Next, wind approximately 95 feet of the wire on the reel. The five feet of wire which is left over is used for a lead-in; and this is connected to the frame of the reel by loosening one of the set screws on the shell of the reel, inserting the wire under the head and then tightening the screw. A three-foot length of the cord may now be used to connect the aerial insulator with the wire hook. After this has been completed the aerial may be packed and it is ready to take on a motor trip, or to camp.

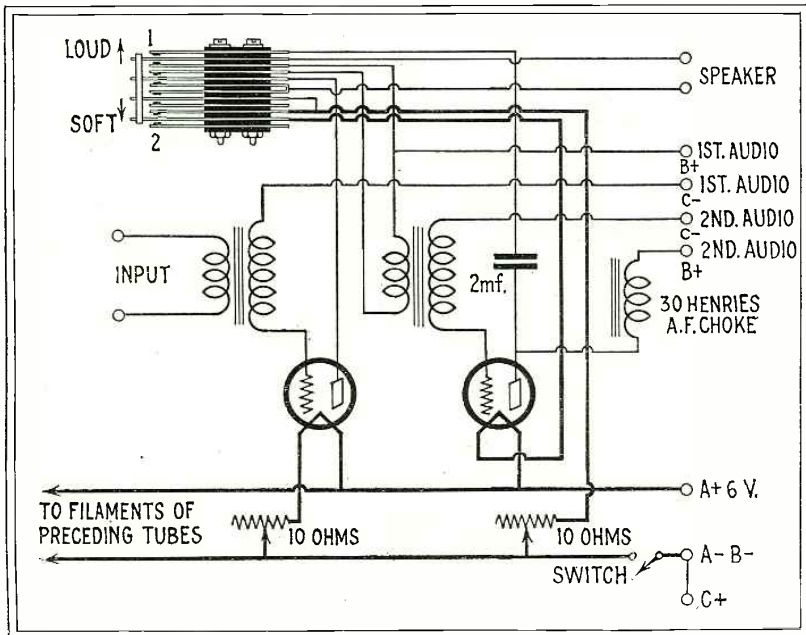

A four-pole, double-throw jack switch is ideal as a stage-control device for an audio amplifier. In the left position only one A.F. stage is in use; while turning the knob to the right connects the second stage.



When it is time to erect the aerial the assembly will be found very simple. First, stop the car at a distance, equal to the required length of the aerial, from some convenient tree or pole. Next, assemble the fishing rod, attach the reel and thread the wire through the leaders. The insulator may now be attached to the end of the wire and then the hook may be caught in position on the tree. The fishing pole may now be strapped to some part of the automobile, and the lead-in wire connected with the aerial post of the receiver.—*L. B. Robbins.*

### A Good Screen-Grid Clip

**M**AKING a connection to the control-grid terminal of a screen-grid tube often presents a problem to the home constructor. This terminal is a cap mounted

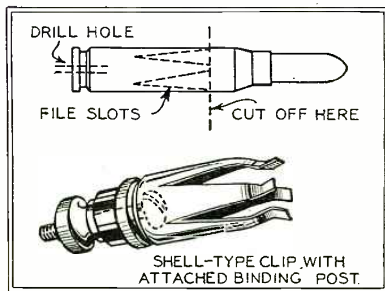

An excellent terminal clip for a 222-type (screen-grid) tube may be made from an empty cartridge shell, with the aid of a file and pliers.

on the top of the tube, and connection must be made to it with a clip. With many of the clips which are used for the purpose the tension is not great enough to insure good contact at all times, and often the set becomes noisy for this reason.

The accompanying drawing shows a simple way to make a good clip for screen-grid tubes from an empty cartridge shell. Any shell between 30 and 45 calibre may be used for the purpose; but the cartridge should be fired before any attempt is made to use the shell. First, saw or file off the shell about three-quarters of an inch from the primer (closed) end or base; and then file four slots at right angles, making four prongs. Next, with a pair of round-nose pliers, bend the tips of the prongs outward a slight distance. Slightly below this bend the prongs should be bent inward sufficiently to fit the terminal snugly. To complete the clip, enlarge the hole through the base to take the machine screw of a binding post.—*Joseph W. Wild.*

### Hints on Linen-Diaphragm Speaker Building

**M**OST of the linen used for the new linen-diaphragm loud speakers will stretch considerably after it has been "doped" and tightened on the frame. For this reason it is advisable to arrange some way of tightening it again without the necessity of rebalancing it, with relation to the driving rod of the unit. Most of the speakers are equipped with a bolt-and-nut arrangement which allows the two diaphragms to be separated in order to tighten them; but this method usually requires the

apex to be realigned so that the driving rod on the unit will not be bent.

For best operation the linen should be drawn as tight as possible without splitting it. The method illustrated here will provide a means of making adjustments without the bother of re-setting the unit. The large diaphragm is mounted rigidly on a strong wooden frame, as shown. The small diaphragm is mounted free and is fastened to the supporting frame by four long bolts. Wing nuts are provided on the back, or a screw driver is used to make adjustments. Each of the bolts should be turned the same distance, in order to keep the frames parallel. The unit is mounted on the frame supporting the small diaphragm. In this way, the relative positions of the unit and the apex of the small cone are kept the same, even though the position of the apex of the cone is changed.

When you make a speaker of this type, it is advisable to "dope" the linen on both sides. The linen is not equally absorbent at all points over its surface, and the use of "dope" on both sides tends to keep the entire coat even. This prevents, to a certain extent, the formation of ridges and bumps which mar the appearance of the speaker and also affect its operation.

The washers used to clamp the apexes of the two cones together often cut the linen at the point where the strain is greatest. This can be prevented, very often, by cor-

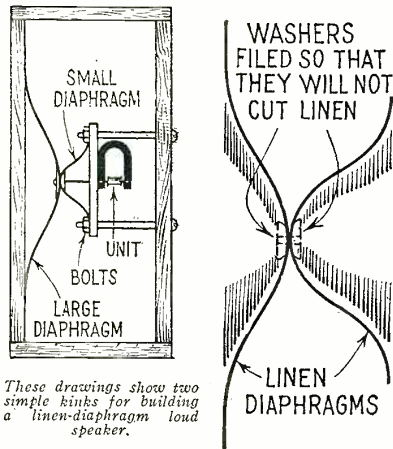

These drawings show two simple knots for building a linen-diaphragm loud speaker.

rectly shaping the washers. The accompanying illustration shows how these washers should be filed; the rounded surfaces prevent the linen from being cut, and the shape tends to enlarge the circle of strain, so that a greater amount of linen holds the weight.

The suggestions outlined above will often increase the volume and quality of a speaker of this kind to a remarkable degree;

**R**ADIO NEWS has received from readers so many letters and ballots requesting more "Wrinkles" that it has been decided to re-establish the department. A year's subscription to RADIO NEWS will be given in compensation for each accepted item. If the author of the wrinkle is already a subscriber, his subscription will be extended one year or he may accept a one year's subscription to Science and Invention or Amazing Stories, both published by the Experimenter Publishing Co.

since the tight diaphragm tends to vibrate over its entire surface, rather than at the apex. This naturally displaces more of the air in the room and, since the larger vibrating surface tends to reproduce the lower notes better, a general improvement is noticed.—*C. W. Palmer.*

### A Phone Cord Reel for DX Fans

**T**HERE are still a great many radio fans who use headphones for receiving short-wave programs as well as DX broadcasts, and a majority of these listeners still continue to register the old complaint regarding the use of phones; namely, that the phone cords are either twisted or in the way. The writer has been troubled by this many times and, as a result, he built a device which keeps the phone cord at minimum length at all times. The drawing on this page gives complete constructional details; and from these it may be seen that the window-shade roller which is located under the radio table reels up the cord when it is not in use, or provides exactly the length of cord required when receiving.

When constructing a phone-cord reel of this type, the first step is to remove the copper peg and washer from the solid end of the roller. Now cut the roller so that it is short enough to fit lengthwise under the radio table. In order to make contact with the phone cord when it is wound on the roller, a swivel bearing with a double contact is required; and for this purpose a radio jack and plug may be used. The plug selected for the purpose should have a large, hollow rubber cap, and the jack will be of the single-circuit type. In fastening the plug to the end of the roller, the copper peg and washer is used as illustrated. However, it is first necessary to drill a 1/4-inch

(Continued on page 178)

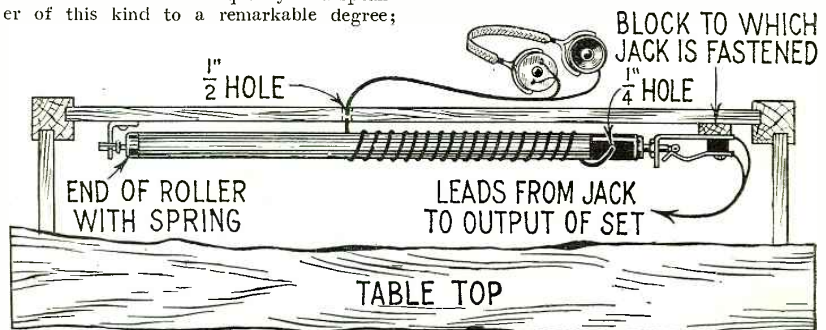

A window-shade roller, fastened under the radio table in the manner indicated above, will keep phone cords out of the way when not in use, yet they are easily pulled out when needed.

# The Zero-Reactance Plate Circuit

Discussion of a System for Obtaining Maximum Efficiency of Energy Transfer in a R. F. Amplifier over the Whole Wave-Band by the Use of Variable Condensers in the Primary Circuits



By Sylvan Harris

**A**LTHOUGH hardly anything has been written, at least in the popular radio journals, concerning the "zero-reactance plate circuit," thoughts on the subject have been in the minds of many radio engineers for a long time; and many of these engineers have tried again and again to find some means utilizing this principle in the radio-frequency amplifier.

The reason for the desire to employ in the R.F. amplifier a system such that the reactance in the plate circuits of the tubes is zero is quite evident to those who have any knowledge of the behavior of electron tubes. For technical information on the subject of the effect of plate load on the operation of the tube readers are referred to a paper by J. M. Miller (Scientific Paper No. 351, of the Bureau of Standards.) For those who do not wish to go into the theory of regeneration, it will be sufficient to state that there are three types of load which we might have in the plate circuits; and the action of each of these is different.

The first case is that of an *inductive* load—exactly the kind of load we always have in radio-frequency amplifiers. The primary of the radio-frequency transformer, aided by the effect of the secondary *via* the coupling, furnishes an inductance in the plate circuit. As a result the tube is caused to regenerate, by virtue of this inductive plate load; the tube *furnishes power* to the circuits and a feed-back current is established which aids in the amplification of the signals being received. (The reader must remember we are not considering circuits wherein a neutralizing scheme is employed.)

The second case is that in which there is no reactance at all in the plate circuits of the tubes. In this case there is no regeneration—the tube circuits *neither furnish nor absorb power*, and consequently the plate-circuit load produces no effect on the amplification, except so far as the voltage step-up in the R.F. transformer is concerned. This case is the subject of this article, so we will leave further details until later on.

The third case—that in which the load in the plate circuit is *capacitive*—is of no particular interest at this time; as the effect

of such a load is, not merely that it does not add to the amplification, but that it actually causes the circuits to *absorb power*.

## REDUCING INDUCTIVE REACTANCE

In the circuit to be described, a variable condenser is connected in series with the primary of the R.F. transformer and the plate of the R.F. amplifier tube, as shown in Fig. 1; and this condenser is controlled simultaneously with the tuning condenser of the succeeding stage. (In the figure the batteries and battery wiring have been omitted for simplicity.) The reason for the insertion of the condenser in the plate circuit has to do with the first case mentioned

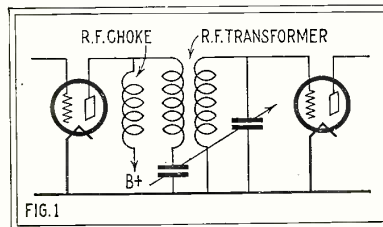

FIG. 1  
The fundamental circuit shown above controls the net reactance of the plate circuit simultaneously with that of the grid circuit.

above. When the inductive load in the plate circuit is great enough, there will not be merely regeneration, but oscillations will be established in the tube circuits. But by adding a capacitive reactance (in series) to an inductive reactance the *net* inductive reactance is reduced. So, by properly adjusting the constants of the plate circuit, the *net inductive reactance* can be kept slightly below the value required for oscillations to occur; and consequently great amplification can be obtained throughout the whole range of broadcasting frequencies.

In order to make this clearer—for we shall be very much concerned about it in all that follows—we may put the idea in the form of a formula; *viz.*:

Net reactance—inductive reactance = capacitive reactance.

The inductive reactance is furnished by

the transformer, and the capacitive reactance is furnished by the condenser. When the capacitive reactance is *less* than the inductive reactance, the *net reactance is inductive*; when the capacitive reactance is *equal* to the inductive reactance, the *net reactance is zero*; and when the capacitive reactance is *greater* than the inductive reactance, the *net reactance is capacitive*.

## R.F. TRANSFORMER DESIGN

There are several reasons for desiring to avoid regeneration which we will not discuss here, as they have been discussed quite lengthily at other times. (See page 1234 of *May RADIO NEWS*, "Regeneration".) But there is one reason which has not been heretofore brought out with any degree of emphasis, and this is that, on account of the tendency of the tube to oscillate, it was not thought possible to use very efficient R.F. transformers between stages.

It is well known that the amount of power which can be transferred from the primary to the secondary of an R.F. transformer becomes greater as we add to the primary turns. But, as we add to them, we also increase the primary inductance; and before long we have the circuits oscillating, which of course does not help out in our design. The interesting part of the matter is that experimenters *did not add enough turns*, as we shall see. Let us see first what happens to the primary inductance of an R.F. transformer as we increase the primary turns.

Suppose we start with a certain number of secondary turns on our transformer—just the right number to enable us to tune over the broadcasting range with a certain tuning condenser. Then let us wind turns on the primary. At first the self-inductance of the primary is small, and likewise the mutual inductance between the primary and secondary windings is also small; the primary will have little effect on the secondary, and *vice versa*. But, as we keep on winding turns on the primary coil, we find that its self-inductance increases steadily and likewise the mutual inductance increases. What happens to the secondary inductance?

The effect of the mutual inductance is to make the secondary act as if its self-inductance were less than it actually is; so that we should soon find, after winding enough turns on the primary, that we could no longer tune over the broadcasting range with our condenser. We would find that we could tune to the short waves well enough, but we would be shy on the longer waves. Then, if we tried to add turns to the secondary to bring us up to the longer waves, we would find that we could not tune down to the shorter waves. At any rate, you see that the tuning range would be cut down. This is an old, old story; as we all know that there have been many sets on the market that could not tune over the complete range of broadcast wavelengths.

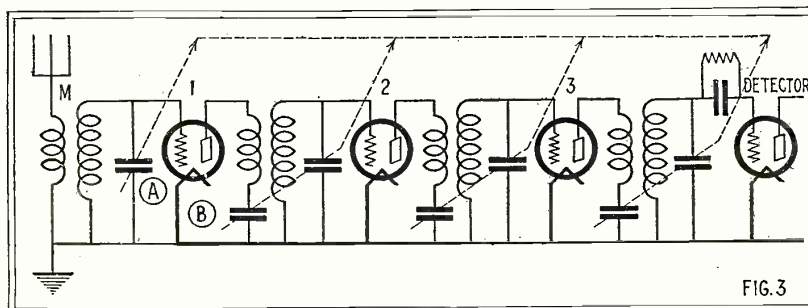

FIG. 3  
Schematic diagram of the R.F. and detector circuits of a two-control receiver embodying this principle. \* If A is out of tune with B, oscillation may result.

Now it must be understood that the secondary has a similar effect on the primary. If we should measure the inductance of the primary by itself, and then measure it when coupled to the secondary, we would find that its inductance in the second case is less than it is in the first case. In other words, the effect of the mutual inductance is to make the "apparent" inductance less than the actual inductance.

**PROBLEMS ENCOUNTERED**

However, as we add turns to the primary, thereby increasing the coupling, we find that our transformer becomes more efficient; i.e., it can transfer more power from the primary to the secondary as we increase the coupling. It would seem that, if we kept on adding turns, we might get to a point where the mutual inductance is equal to the self-inductance of the primary winding, and the apparent inductance of the primary would become zero, the condition for which we are looking. Unfortunately, however, the primary self-inductance increases more rapidly than the mutual inductance; so that this cannot be. However, what remains of the primary inductance can be nullified by a series condenser such as we have shown in Fig. 1.

As we keep on adding turns, however, we soon begin to encounter another effect—one which is well known to hams—and that is that we are soon able to tune in the same station at two different settings of the tuning condenser. This is known as the "double-resonance effect" of R.F. coupling circuits. At first the humps or resonances are close together, so that the set seems to tune broadly; but later on, as we increase the coupling, we can clearly distinguish the humps, and can make them as far apart as we please. In fact, the writer at one time constructed a receiver with such close coupling in the R.F. transformers that the receiver became automatically a double-range receiver, dividing the broadcasting band into two almost equal bands; so that a station of 250 meters wavelength would tune in at almost the same setting of the condenser as one of 500 meters. (Radio News for March, 1926, "An Automatic Double-Range Receiver.")

However, it is possible to make the coupling so close that one of these resonances is outside of the range of broadcast wavelengths. This is what happens in an auto-

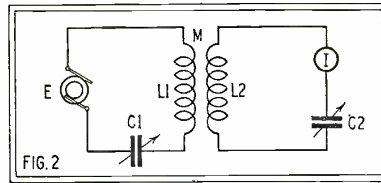

There will be a maximum of current flow, at any frequency, when L1 equals L2 and C1 equals C2.

transformer which has a coupling of 100 per cent; one resonance frequency occurs in the band where we want it to occur; the other resonance frequency is relegated to infinity (zero wavelength).

**DESIGN OF THE CIRCUIT**

We have now sufficient information to be able to understand how the zero-reactance plate circuit works out. In Fig. 2 we have a simple A.C. circuit, consisting of two tuned circuits coupled together. We have made the primary inductance L1 equal to the secondary inductance L2 and, likewise, the primary capacity C1 equal to the secondary capacity C2. Under such conditions, no matter what the frequency of the voltage E may be, we shall always have a maximum of current flowing through the current-measuring device I, located in the secondary. If either of the inductances or capacities should be changed, the secondary current would decrease. What have we done?

We have made the two inductances equal to each other, so that the *apparent* primary inductance is equal to the *apparent* secondary inductance. In other words:

$$L1 - M = L2 - M$$

Then the secondary capacity C2 nullifies the apparent secondary inductance, and the primary capacity nullifies the apparent primary inductance. The secondary circuit is therefore in resonance and the primary is also in resonance, simultaneously. The two capacities have to be always equal, so we must have two identical condensers rotating on the same shaft.

The mutual inductance is made as large as possible, so that one of the resonance humps will be as far as possible below the range to be covered. By employing such close coupling we are making our transformer a very efficient one. Moreover, since

the primary circuit is in resonance with the incoming signal frequency, its *net reactance to that frequency is zero*. In order to apply the principle to an R.F. amplifier, all that we have to do is to replace the generator E by the voltage at the plate of a tube, and to connect the condenser C2 across the input to another tube. We have done this in Fig. 3, which shows a three-stage amplifier and detector, with two controls. We have illustrated a two-control circuit in order to point out a very interesting matter,

**CIRCUIT PECULIARITIES**

It is clear, on comparing Fig. 2 with Fig. 3, that, when a signal of a certain frequency excites the antenna, and all or the condensers are tuned to resonance, the reactance in the plate circuit of each tube is zero. Take for instance the second stage: its plate circuit is always tuned to exactly the same frequency as its input circuit. Consequently, the reactance of the plate circuit to the frequency that could excite the input circuit would be zero. As a result, there would be no oscillations established in that stage, nor would there be any regeneration.

On the other hand, let us consider the first stage, which has its condenser independently controlled. Suppose we start out with this condenser tuned the same as the others. There would be no regeneration in the first stage. However, suppose we tune condenser A to a higher frequency (shorter wavelength) than the other condensers. The plate circuit B would then be tuned to a wavelength greater than that of a signal which could excite the tuned circuit A. In other words, there would be inductive reactance in the circuit B when A is tuned lower than B; and, as a matter of fact, oscillations will be established when A differs but slightly from B.

It is clear then, and this is very interesting, that when *all* the circuits are exactly in tune with each other, there is neither regeneration nor oscillation; but when any one of the circuits is *out of tune* we can have both regeneration and oscillation, depending on how far out of tune the circuit is. As was said before, the input circuit need not be out of tune with the output very much; as it has been found that the influence of the antenna circuit, through the loose coupling M, is sufficient to throw

(Continued on page 164)

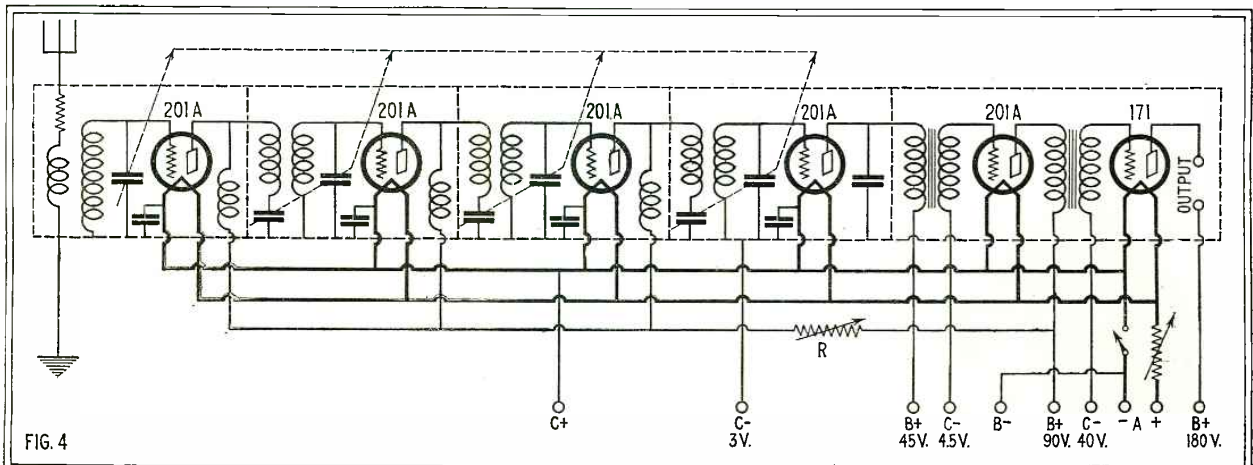

Diagram of a receiver designed by the author, in which the zero-reactance principle was employed in the three R.F. plate circuits, by the use of a seven-gang condenser. The primaries have the same number of turns as the secondaries, which are smaller than usual.

# Learning the Code Multiplies Radio Pleasures



Enjoyment of Short-Wave Reception is Increased a Hundredfold by a Few Lessons which Enable the Listener to Understand the Secrets of the Air



By C. Walter Palmer

**D**O you want to have more fun with that short-wave receiver? Has some of the thrill of listening to short-wave broadcast stations worn off? DX music on the short wavelengths is only a small part of the enjoyment that you should get with your set. In order to appreciate it fully, you must listen to everything that can be heard. Why not learn the code? It is not very difficult. In fact, you will be surprised how much progress you can make in a short time.

Everyone who has operated a short-wave set has heard the amateur and commercial code stations—and may have been annoyed by them. These signals, however, have an attraction that can be realized only by those who have listened to, and communicated with the operators of these stations. There are over 20,000 amateurs in the world at present and many of them can be heard at any time on the various short-wave bands allotted to them. It is true that a small percentage of these amateurs have equipped their transmitters with modulating systems so that they can transmit voice; but they are comparatively rare. The reason for this is that phone transmitters cannot be heard as far as continuous waves and the attraction is not nearly as great.

In order to get the greatest enjoyment from radio it is necessary to understand all that is going on. Broadcast reception covers only a very small part of this; since the thrill of hearing far-distant broadcasting soon gives way to a search for better quality, and it is usually only a matter of a few months or a year before the novelty wears off.

Another advantage of learning the code is that there are a number of stations which are controlled by quartz crystals and other devices, so that an absolutely constant frequency is maintained. This is of particular service in calibrating wavemeters and receivers; but it is necessary to know the

code in order to know which station is being received. It must be remembered that any change in the aerial, coils and other apparatus in the set will change the calibration and necessitate recalibrating.

## HOW TO BEGIN

The apparent difficulty in learning the code usually discourages fans; but those who "brave the storm" are usually surprised at the progress that can be attained by a few hours' concentration in memorizing the code letters and learning the sounds of the letters. There are several methods which may be followed in learning the code, although the easiest is probably that in which two or more persons practice together.

First you must memorize the code letters. Do this by pronouncing the symbols as "dit" and "darr" rather than "dot" and "dash," so that you will learn the *sound* of the signals rather than the way they look in print. Do not visualize the letters as "dash, dot, dot, dot" for "h," etc.; but associate the sound of the complete signal with the letter. Master a few of the letters every day by repeating the sound of the symbols until the complete alphabet is known.

Then get a friend to "review" you until you can give the correct symbol without hesitating. Practice until you know the sounds as letters without thinking of the dots and dashes. Do not expect to learn the complete code thoroughly in one day. Take your time and learn a few letters each day so that you will know every one. It is a good plan to review the signals you learned the previous day before continuing on new ones. As soon as you have memorized the code, you should put it to practical use. Make a buzzer practice set as shown on this page.

## PRACTICING

The complete outfit will not cost much

more than one dollar. Obtain a telegraph key, buzzer, a 4½-volt "C" battery and a .001-mf. fixed condenser. Obtain a key with rather heavy contacts and a good solid lever. One of the regular telegraph keys, which can be obtained for a very small amount, will be ideal for this purpose. A key of this type will help you to send evenly. Buy a buzzer with a high-pitched note if possible; since this will more nearly match the tones produced by continuous-wave transmitters than does the ordinary low-pitched buzzer. The only other apparatus necessary is a pair of headphones, which you probably already own.

If it is at all possible, get some amateur in the neighborhood to send to you at first;

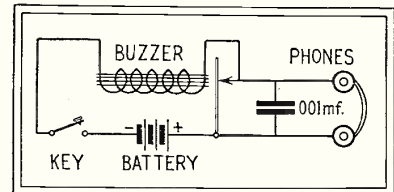

A simple circuit for code practice, which may be used as shown in the picture below.

so that you will get acquainted with the "swing" that is used in sending. However, there is another method equally effective if you do not know anyone who can send for you; this will be explained later. When sending slowly, make the letters clear-cut and use wide spacing between the letters to attain the slow rate. When practicing, do not try to send too fast, since this will cause the signals to be choppy and uneven.

## HOW TO SEND

When using a key, place it about eighteen inches from the edge of the table in a line with your arm. Adjust the spring on the key, so that there is a slight tension when it is pressed down. Leave a gap of about one-sixteenth of an inch to give a free swinging motion. Use rather heavy spring tension at first, so that the spacing will be kept steady. Hold the key lightly with the thumb resting on one side of the knob and the first and second fingers on the top. Bend these two fingers slightly and keep a light grip on the knob. Do not let the other two fingers touch the key. You will see the correct manner in the illustration reproduced here from a photograph. Use a steady wrist motion, so that your wrist and fingers will not become tired. The main thing to remember is to keep your fingers relaxed and not to squeeze the knob too tightly.

Leave a spacing equal to about *one dot* between parts of the same letter and use a spacing equal to three dots between letters and five dots between words. Make a dash about three times the length of a dot. Of course, the exact spacing between letters depends upon the rate of sending,

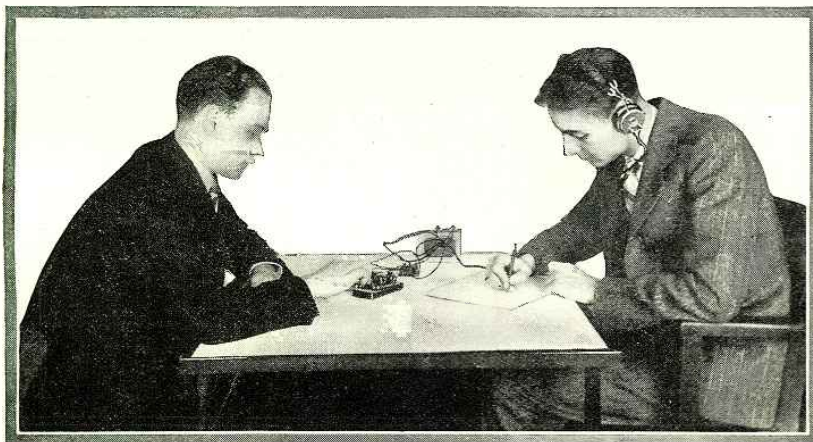

The best way to learn the code is to rig up the simple circuit shown above, and have a friend send to you. After a few lessons, short-wave reception will be far more interesting.

since you must make the letters clear and sharp cut when sending slow. It is not advisable to lengthen the dots and dashes, even though you are sending very slowly, since this tends to slur the transmission and makes it more difficult to receive.

**TAKING DOWN CODE**

If you cannot enlist an experienced operator, it is better to depend on slow signals received from the short-wave or long-wave stations. There are a number of commercial stations operating on short waves and some of them transmit quite slowly. Many of these stations use tape transmission and their signals are quite regular. The speed which they use depends upon the reception conditions and it is usually an easy matter to find one at about the desired speed for code practice.

At first you will be able to pick out only one or two letters, but do not let this discourage you. In a short time you will find that you can distinguish more of the letters. Use a paper and pencil and mark the letters down as they are received. Do not write the dots and dashes, as this will not help you to increase your speed and it will prevent you from reading letters instead of dots and dashes. Repeat this practice as often as possible for periods of about a half hour.

Learning the code by this method will probably seem more difficult than the use of a buzzer system. However, when listening with a radio set, you encounter the actual operating conditions, including interference and static, which are encountered whenever you are copying code signals. In this way, you become used to these interfering noises from the beginning and naturally you will encounter no difficulty with getting used to these noises and the irregularities of hand transmission.

**SOME ABBREVIATIONS**

You will soon find that operators do not always spell out the complete words but abbreviate a number of them in order to save time. Thus instead of sending the word working, it will be sent *wk/g*. You will be able to interpret most of the other abbreviations in the same manner. A list of some of them is given below.

- |                        |                      |
|------------------------|----------------------|
| ART—All right          | NM—No more           |
| CANS—Phones            | TT—That              |
| CP—Counterpoise        | WK—Work, weak, week, |
| ES—And                 | well-known           |
| FB—Fine business, very | WX—Weather           |
| good                   | XMTR—Transmitter     |
| FR—For                 | YL—Young lady        |
| GB—Good-by             | 73—Best regards      |
| GM—Good morning        | 88—Love and kisses   |
| III—Laughter, high     | 99—Keep out          |
| ND—Nothing doing       | 2DA—Today            |
| NIL—Nothing            |                      |

There are also several lists of official signals used by commercial and government stations and also employed to some extent by amateurs. Among these are the "Q" signals, employed primarily by ships at sea but used by amateurs; although the common usage by amateurs sometimes differs slightly from the official meaning. The "Z" are used by the U. S. Naval Communication Service; these signals have somewhat kindred meanings to the "Q" signals. These abbreviations are very seldom heard in amateur circles.

**SHORT CUTS**

From time to time, a number of short cuts to learning the code have been introduced. Some of these methods have good points but, when you get down to facts,

learning the code is a matter of practice and, although they may produce quicker results, it is still necessary to practice continually until you completely master the code. Automatic senders are of some assistance, especially since such instruments are used by the radio inspector when giving the operator's license tests.

When using the "listening" method you should try to pick out stations which are transmitting just a little faster than you can receive. In this way, you will always try to get the few letters which you miss and you will increase your reception speed. When writing down the message, try to make the separation between the words definite. It is a good plan to receive the complete word before starting to write it down; write the word while listening to the beginning of the succeeding word. A little practice in this matter will soon make it

easy to copy "behind" the incoming signals, and the results will be gratifying.

**FOREIGN STATIONS**

Besides the American stations which will be picked up on short waves, there are a number of amateurs transmitting in foreign countries. Because of the remarkable distances that can be covered on short waves, especially with continuous-wave transmitters, it is not by any means unusual to receive these foreign stations with considerable volume and clarity. These can be identified by the "intermediate signals," which were arranged by the International Amateur Radio Union, and are used throughout the world. Several years ago the letters "de" were used before signing the call letters of the station. Now the intermediate signal is used in place of this introduction.

*(Continued on page 183)*

International Morse Code		
[To be used for all general public-service radio communication.		
(1) A dash is equal to three dots; (2) the space between parts of the same letter is equal to one dot; (3) the space between two letters is equal to three dots; (4) the space between two words is equal to five dots.]		
A .—	Period .....	.. . .
B —...	Semicolon .....	— . — . — .
C —.—.	Comma .....	— . — . —
D —..	Colon .....	— — — . . .
E .	Interrogation .....	.. — — . .
F ..—.	Exclamation point .....	— . — . — —
G —.—.	Apostrophe .....	. — — — — .
H ....	Hyphen .....	— . . . . —
I ..	Bar indicating fraction .....	.. . . .
J —.— —	Parenthesis .....	— . — . — .
K —.—	Inverted commas .....	. — . . . .
L —...—	Underline .....	.. . . — —
M — —	Double dash .....	— . . . —
N — .	Distress call .....	.. . . . . . . . .
O — — —	Attention call to precede every transmission .....	— . — . — —
P — — . —	General inquiry call .....	— . — . — . — . — .
Q — — — —	Á (German)	.. . . .
R . — .	À or A (Spanish-Scandinavian)	— . . . .
S ...	CH (German-Spanish)	— . — . — .
T —	Ê (French)	.. . . .
U ..—	Ë (Spanish)	— . . . .
V ..— —	Ö (German)	— . . . .
W — — —	Ü (German)	.. . . .
X — . . .	1 . — — — —	Error .....
Y — . — —	2 — — — —	Received (O. K.) .....
Z — — . .	3 .. . — —	Position report (to precede all position messages) .....
	4 . . . . —	End of each message (cross) .....
	5 . . . . .	Transmission finished (end of work) (conclusion of correspondence) .....
	6 — . . . .	
	7 — . . . . .	
	8 — — . . . .	
	9 — — — . . .	
	0 — — — — .	

*The "dots and dashes" of the code, which, however, are never heard as such by the practical listener, to whom each letter and character has its highly-individual sound.*

# Letters from Home Radio Constructors

## HIGH-VOLTAGE INTERFERENCE

Editor, RADIO NEWS:

I am writing to you for the blueprint of the Short-Wave receiver. (Sorry, but you will have to come again with your street address. Los Angeles has grown in the past forty years.—EDITOR.) I intend to build it. Can this be put in boxes, so as to shield it? (There is no particular value in doing so, unless close to interference; very large cans would be needed.) I think it would help to clear up distance reception. Please tell what kind of aerial is best suited for it. (There is very little difference, so long as the antenna system is a good energy collector. Short-wave aerials have nowhere near the period of the signals they are receiving, and except for point-to-point reception, there would be no use in attempting to make one directional.

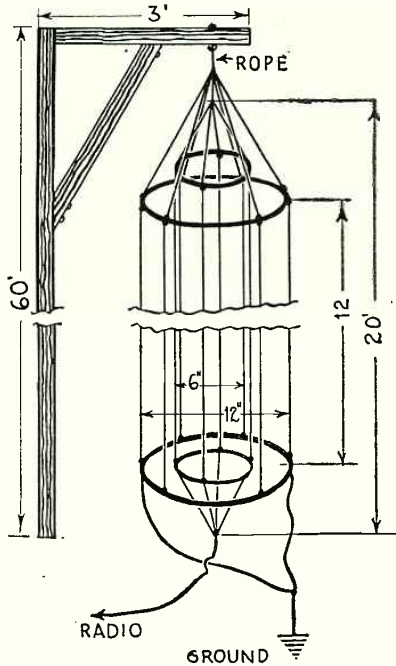

Mr. Morgan suspends two grounded rings outside his vertical cage aerial, to conduct away induced high voltages.

I am always glad to get your paper, which is not a catalog. I like Dr. Chase's letters and also that from Max Hamilton, of Porterville; I once ran a shop in Porterville. But a paper can't get on without advertisements. Good firms that produce real stuff are O. K., but your way of testing it out is best. Honesty is a nice thing to depend on when you read an "ad."

I have an aerial 60 feet high, with a vertical

5-wire cage 20 feet long, all enameled. My aerial is within 100 yards of a 60,000-volt line; so I had some trouble until I got two aluminum rings, 6 inches larger than the aerial, and hung one at the top and one near the bottom and grounded them. This improved matters so that I get good reception in the daytime. I got this idea from power engineers, who use this idea near their transmission lines, and it might be of some help to those who live close to high-tension lines.

HARRY MORGAN,  
Los Angeles, Calif.

## NO REASON TO DOUBT IT

Editor, RADIO NEWS:

Just a few words to let you know how good my Peridyne is.

Sunday morning, March 4, between 1.30 A. M. and 3.15 A. M., Eastern Standard Time, I tuned in the following Pacific Coast stations: KGO, Oakland; KPO, San Francisco; KFSD, San Diego; KFRC, San Francisco; KFI, Los Angeles; KGW, Portland, Oregon.

I tuned in KGW just before 3.00 o'clock, Eastern Standard Time. At the end of the program he announced it was 12.01, Pacific Time, announced the program for the next day, and signed off.

My Peridyne has three separate Amsco Condensers, using Marco Dials, because I had no gang condensers. I am also using three audio stages, using two National Impedaformers and one Thordarson transformer.

WEAF comes in on the dials at 95-95.96½; WGY on the dials at 78-78.81½. Monday evening, March 5, between 7 and 8 P. M., at 10-5 and 13 on the dials, I was listening to amateurs talking. Michigan calling CQ came in very loud and clear. I wonder if all Peridyne sets can tune in amateur stations. (Depends upon the coils used.—EDITOR.)

Wednesday morning, March 7, between 1.30 a. m. and 3.05, E.S.T., I tuned in the following Pacific Coast stations: KFRC, San Francisco (not very loud); KPO, San Francisco; KFI, Los Angeles; KGW, Portland, Oregon; KHQ, Spokane, Washington. I had KHQ from 2.25 a. m. to 3.05 a. m., when it signed off. Am sending program to KHQ to have it verified.

You may not believe this statement, but I received KFI eleven times in succession between Feb. 15 and Feb. 26. Some nights I could just hear it, and other nights it came in loud.

MARSHALL FOWLER,  
88 Main Street, Williamstown, Mass.

## A COMPLETE COMBINATION

Editor, RADIO NEWS:

I enclose pictures of a special radio combination built by myself that includes everything, and may hit close enough to be called an ideal combination, complete in one cabinet.

As the top view shows, in addition to a broadcast receiver, it contains a phonograph with electric pick-up and a short-wave set; the latter is controlled by the top dials on the panel. The regular broadcast set is operated by the lower dials; the round hole at the right, as will be seen from the inside view, is backed by a cone speaker. The clock at the right is wound by a dry-cell battery.

The grill in the wall at the right covers an 84-inch Racon air-column horn. On the panel is a double-throw jack switch which enables the operator to use either speaker at will. All leads are through receptacles in the wall.

A single power supply operates either the short-wave or the broadcast set; either may be connected in an instant by the double-throw switches. The former is an Aero-Dyne with Erla transformers, the latter a Bremer-Tully Counterphase with three autoformer stages. In both the first and second A.F. stages 112 tubes are used, and a 210 in the last. A Bakelite "A" unit and Thordarson 210 compact are used. The phonograph pick-up is provided with a double-circuit filament jack on the back of the cabinet to plug it in. This disconnects the R.F. and detector filaments at the same time.

JOE BENNETT,  
527 North Lincoln St., Bloomington, Ind.

## A DYNAMIC SPEAKER

Editor, RADIO NEWS:

Thinking that some other readers may be contemplating the construction of a dynamic speaker from an old R3 Magnavox unit, as described by Mr. Nichols in your May number, I enclose herewith photograph of such a speaker which I recently completed, together with a few suggestions.

LETTERS for this page should be as short as possible, for so many are received that all cannot be printed. Unless a set is made from a published description, a schematic sketch should be sent; photos can be used only to illustrate a novelty, and then only if large and very clear. Inquiries for information not given here should be sent to the constructor direct; but he should NOT be asked to furnish data already published, here or elsewhere.

This department is for free discussion to the extent that space permits; but RADIO NEWS accepts no responsibility for the opinions of readers as to the relative merits of apparatus and circuits.

For a cone support, instead of long brace rods to a baffle board, I secured a Ford headlight reflector, which is just about the right size and shape. This is made of soft brass, easily worked, and will not affect the field of your electromagnet. By cutting suitable holes in the sides to prevent the air "binding" at the back of the cone, and in the bottom to fit the part of the bridge which formerly supported the diaphragm, and soldering the two parts together, you have a very strong, rigid unit in which the cone is well protected.

Making this change necessitated supporting the rear end of the cone by some method other than that used by Mr. Nichols. This was done by soldering to the center pole of the electromagnet a small piece (taken from an old rheostat) ¼-inch in diameter and ¼-inch long. A disc-bridge arrangement, made from the same paper as the cone, was glued behind the cone, and can be secured in any position through a hole in the center

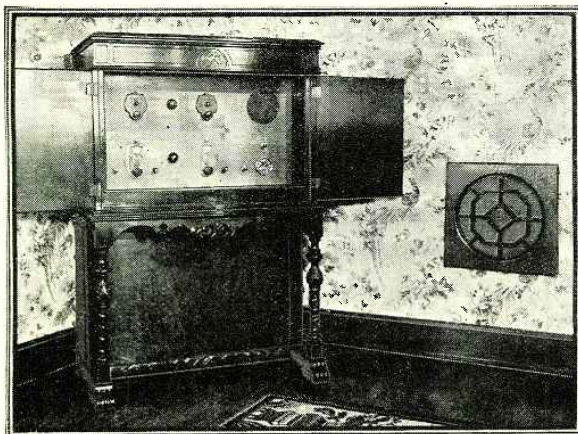

Mr. Bennett's combination covers everything; short and long waves and phonograph, with a choice of exponential horn (built into the wall) or cone speaker.

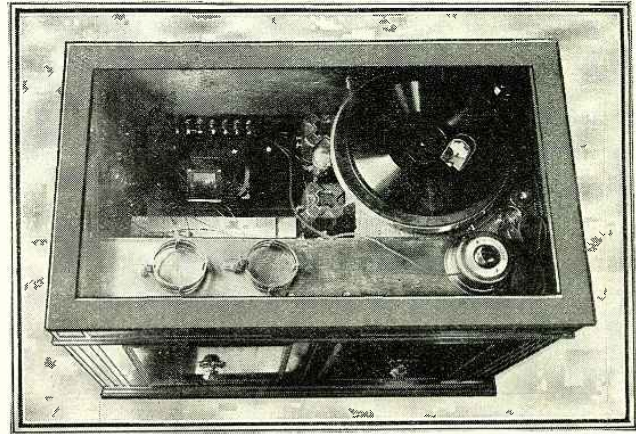

The short-wave coils are visible, in this view looking down into the cabinet, on an upper baseboard; the phonograph motorboard at the upper right. The broadcast receiver can be seen at the upper left.





HERE'S TO GOOD OLD ALE—

PROSIT! FOR TELEVISION



Television discovery in Popular Radio for May: "In this sort of scanning device, the holes are arranged on a belt which passes over two wheels, one of which supplies the DRINKING FORCE." This affords possibilities of making new discoveries in the coming radio art; but the problem of avoiding the well-known double-image effect may become serious.—E. Gibbs.

image effect may become serious.—E. Gibbs.

THAT'S REAL INSULATION

Thoroughness of the immobile East revealed by the price list of Messrs. Deva Dutta Sarangi & Son, Calcutta: "Insulating materials, leatheroid 10 MILES and 20 MILES, thick at Rs 1-5-6 per lb." The users of this stuff must be going in for safety first at any price; possibly have been reading about those 6 trillion volts of lightning.—C. M. Sweet (India).



NO SAHIB, THIS IS NOT THE CHINESE WALL WEREY A SMALL INSULATOR

REVENGE IS SWEET!

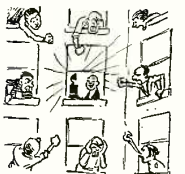

Interesting possibility in an ad in the Detroit News of April 22: "West-on Radio set, PESTER, \$50 cash." At first we hoped no one in our vicinity would get hold of it; there are too many radio pests around. Then we felt a fiendish temptation to acquire this instrument of retaliation and square up accounts with them.—Wm. G. Mortimer.

with them.—Wm. G. Mortimer.

BUT THEY MARRY TALL ONES

Matrimonial tendencies in the Dominion revealed in the Rochester Times-Union of March 13: "Canada demands increase in wave channels; ask increase of eight WIFE LENGTHS." This comes as a surprise to us, who had always pictured the gallant Canuck snuggling up to some petite, brunette beauty of the northern wilds.—John C. Heberger, SAEC.



THIS IS SO SUDDEN!  
AH-H MADEMOISELLE I LONG FOR ZEE LONG WIFE!

RELIEF EXPEDITION ADVISED

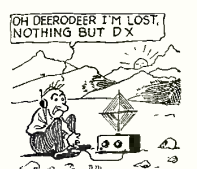

Perilous state of the "hams" revealed by the Portland Oregon Journal of April 29: "It has always been the LOST of the amateur to explore and develop new territory." Here is a great field for social workers and home missionaries among these poor souls, whose condition must fill any sympathetic soul with alarm.—B. A. Oscarson, 7ADT, 7LD.

alarm.—B. A. Oscarson, 7ADT, 7LD.

NO CLOSED SEASON

Sporting tip given by the New Orleans Times-Picayune of May 13: "Improvement in the sharpness of a superheterodyne may be had by HUNTING a .0005 variable condenser across the secondary of the filter transformer." A well-trained pack of condenser hounds, used to the tricks of the wily variables, and a good 20-gauge may be used.—H. A. Perez.



TEE HEE!

DIPLOMACY DE LUXE



A large part of our foreign representation will soon be obtained by the efficient use of radio, according to this announcement in the Regina (Sask.) Morning Leader of May 3: "Radio, CONSUL model, 5 tube, complete." In that case, as before, fidelity, harmony, sensitivity, quality, polish and non-radiation should govern an appointment.—Wilfred J. Burns.

govern an appointment.—Wilfred J. Burns.

WE'VE GOT A BASEBOARD ALREADY

Neglect of opportunities on the part of set owners, explained by the N. Z. Radio Record of March 2: "6W is usually passed over as a harmonic, and this is probably the reason why the TRANSFORMERS are received here by so few short-wave listeners." If we had the right sets of plug-in coils, could we receive our condensers and sockets too?—A. E. Ireland (New Zealand).

MARVELOUS!



sockets too?—A. E. Ireland (New Zealand).

WHAT QUAIN BOOSTING ZEAL



Civic pride, than which there is no whither, revealed in a Weirther, W Va., dispatch to the Steubenville Herald-Star of May 2: "The local station WQBZ broadcast with 2449.9 meters am 200 kilowatts." And, perhaps, 12,000 kilocycles, the inspired reporter had come down to that. To get this station, you just wind 1492 more turns of wire on each coil and plug in the loud speaker ahead of the detector.—Theodore J. Sohn.

wind 1492 more turns of wire on each coil and plug in the loud speaker ahead of the detector.—Theodore J. Sohn.

DIT-DIT-DIT, WENT THE HAMMER ON THE ANVIL

Praise of a fellow-townsmen in the Worcester (Mass.) Telegram of April 22—"Through his work as an 'IRON POUNDER,' Bates has caused the name of Worcester to sound from coast to coast"—will, we know, cause other "hams" to call right away for the dope from IGY as to how he gets that loud clear note.—Luther W. Eldridge.



AIN'T THEY CUNNING? (ONLY SIX)



Note from the capital of the movie world, enclosing cover of Radio Doings for April 8 with announcement of a "six-tube, self-contained, single station selector, using the new CUNNING AC tubes," inquires earnestly "If they are cunning now, what will they be when they grow up? (You tell 'em, Frank: we've got our girl friend along.—Frank S. Scott.

we've got our girl friend along.—Frank S. Scott.

NEIGH! NEIGH!!

Influence of Spring in the Golden State upon observers and typographers, noted in the Stockton (Calif.) Evening Record of April 20: "Wild-Horse RADIO to be staged this week-end." Oh, gee, gosh! We have heard radios that squealed like dogs and pigs, but is this to be worse? Or is it one of those sets that you need wild horses to drag a peep out of?—Stiles Martin.



drag a peep out of?—Stiles Martin.

WE WANT OURS BUTTERED



Welcome to the crew of the Bremen as characterized by the Detroit News of April 29: "The BROADCAST will begin at 9:15 a. m. McNamee will assume the task." This solves one important question; it was Graham bread thus cast upon the ether. But what we would like to ask Mac is, how many of the leaves have returned again?—Clarence W. Schneider.

have returned again?—Clarence W. Schneider.

THERE WERE GIANTS IN THOSE DAYS

Out into the Great West, where men are men and the ladies too are husky, Montgomery Ward & Co., sent their winter catalog offering "Bus Bar Wire 10 Ft. Square." Johnny Inkslinger writes us that Paul Bunyan bought some and wired up his set—losses were so low he got Uranus on it, but the only way to move it was to hitch Babe the Blue Ox to the baseboard.—Donald Courcy.

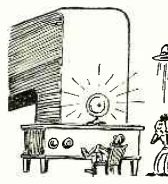

AN ALL-FIRED SIMPLE OUTFIT

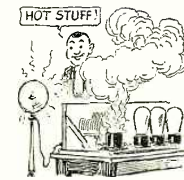

New engineering practice explained in Allen-Rogers-Madison's 1928 catalog, listing a short-wave kit: "The main unit, including socket is FIRED, insuring uniformity of range and greatly simplifying construction." Also bringing about red-hot reception on long-distance programs, though sometimes burning out tubes in that fired socket.—J. W. Myers.

out tubes in that fired socket.—J. W. Myers.

REMOTE CONTROL RECOMMENDED

New wrinkle from the Chi-Rad 1928 spring catalog, describing a well-known vernier dial which "is still one of the best and is now microphonic." We have been taught by hard-earned experience to keep the speaker off the cabinet, and now we will have to put the dials on the other side of the room from the panel. Something's always making more work on the set.—W. H. Balderston.

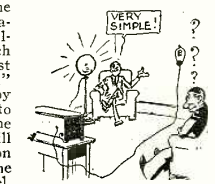

VERY SIMPLE!





# Radio News Laboratories



**RADIO** manufacturers are invited to send to RADIO NEWS LABORATORIES samples of their products for test. It does not matter whether or not they advertise in RADIO NEWS, the RADIO NEWS LABORATORIES being an independent organization, with the improvement of radio apparatus as its aim. If, after being tested, the instruments submitted prove to be built according to modern radio engineering practice, they will each be awarded a certificate of merit; and that apparatus which embodies novel, as well as meritorious features in design and operation, will be described in this department, or in the "What New in Radio" department, as its news value and general interest for our readers shall deserve. If the apparatus does not pass the Laboratory tests, it will be returned to the manufacturer with suggestions for improve-

ments. No "write-ups" sent by manufacturers are published in these pages, and only apparatus which has been tested in the Laboratories and found of good mechanical and electrical construction is given a certificate. As the service of the RADIO NEWS LABORATORIES is free to all manufacturers, whether they are advertisers or not, it is necessary that all goods to be tested be forwarded prepaid, otherwise they cannot be accepted. Apparatus ready for, or already on, the market will be tested for manufacturers free of charge. Apparatus in process of development will be tested at a charge of \$2.00 per hour required to do the work. Address all communications and all parcels to RADIO NEWS LABORATORIES, 230 Fifth Avenue, New York City. Readers will be informed on request if any article has been issued a Certificate of Merit.

## PHONOGRAPH PICK-UP

The "phone link" shown, submitted by The Phone Link Company, 490 Broome Street, New York City, is a phonograph pick-up of the variable air-gap type. The vibrating armature which carries the phonograph needle is hinged to one of the pole pieces and is held in position by pressure between a flat "U"-shaped spring, covered with soft rubber, and a thicker rubber strip. The air-gap between the vibrating armature and the pole pieces carrying the pick-up coil may be varied by means of a special screw, which presses on the rubber strip; a very exact volume control thus is obtained. This unit is housed in a light aluminum casing which is attached to a hinged arm pivoting upon a conical support, ordinarily placed on the motor-board of the phonograph. Two adapters, a UX and a UY type, make possible the connection of this instrument to a receiver with either a 4- or a 5-prong detector. Each adapter consists of a small bakelite plate with

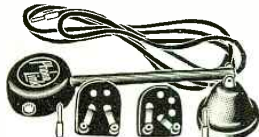

4 or 5 holes into which fit the prongs of the corresponding detector tube; two flat springs, partly engaged in the holes for the grid and cathode (or "A+") prongs are connected to two pin jacks mounted on the same plate, and into which are plugged the tips of the connecting cord. This pick-up is thus connected ahead of the detector tube, which is replaced in its socket. The device is very light and does not wear out the phonograph records as the heavier types do. The reproduction of speech and music is of very good quality, and large volume may be obtained with radio receivers having a good audio amplifier.

AWARDED THE RADIO NEWS LABORATORIES CERTIFICATE OF MERIT NO. 2362.

## A.C. WIRE KIT

The "Colorubber" A.C. wire kit, submitted by the Belden Mfg. Company, 2300 S. Western Ave., Chi-

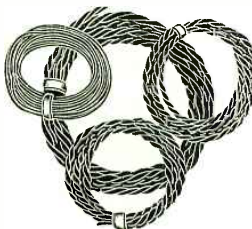

cago, Illinois, contains four coils of flexible rubber insulated wire, sufficient for the wiring of the average A.C.-operated radio receiver. There are 12 feet of black No. 14 twisted pair for the 1½-volt amplifier circuit; 6 feet of yellow No. 18 twisted pair for the 2½-volt detector circuit; 6 feet of red of the same gauge for the 5-volt power-tube circuit, and 25 feet of green No. 18 hook-up wire for the rest of the connections.

AWARDED THE RADIO NEWS LABORATORIES CERTIFICATE OF MERIT NO. 2363.

## FIXED CONDENSER

The "Tipon" vacuum mica condenser, submitted by the Tobe Deutschmann Company, 11 Windsor



Street, Cambridge, Mass., has its capacity elements sealed into an evacuated glass tube, and is thus protected from atmospheric influences. This condenser is the size of a standard grid-leak and, being equipped with two contact caps, fits in any standard grid-leak mounting. It is available in the most used capacity values; the tested units differ from the rated values less than 10%.

AWARDED THE RADIO NEWS LABORATORIES CERTIFICATE OF MERIT NO. 2364.

## CENTER-TAPPED RESISTORS

The resistor shown, submitted by the General Coil Company, 25 Sterling Street, Weymouth, Mass., is

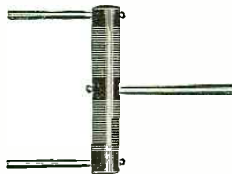

center-tapped and made for use across the filaments of vacuum tubes operating on raw A.C. The two sections of this resistor are wound in opposite directions on a fiber tube 1½ inches long and ¼-inch in diameter. The resistance value of this unit is approximately 65 ohms and the taps are so precisely located that the difference in resistance between the two halves has been found to be less than 0.3%.

AWARDED THE RADIO NEWS LABORATORIES CERTIFICATE OF MERIT NO. 2365.

## POWER TRANSFORMERS

The type T-2900 "B" power transformer, submitted by the Thor-



daron Elec. Mfg. Company, Chicago, Ill., operates on a 110-volt 50-60-cycle house-lighting line, and is designed to supply the "B" power necessary for satisfactory operation of a radio receiver employing a single power tube of the UX-250 type in the last stage. This transformer operates in conjunction with two half-wave rectifiers of the UX-281 type, and has three center-tapped windings. Two low-voltage windings, rated at 7½ volts, provide the heating current for the filaments of the rectifiers and the power tube. The high-voltage winding, for the plate supply, has been found to deliver approximately 2 x 670 volts under full load. The apparatus is well built, sturdy and compact, and easy to install.

AWARDED THE RADIO NEWS LABORATORIES CERTIFICATE OF MERIT NO. 2366.

The type T-2950 "D" power transformer, submitted by the same company, is similar in construction to

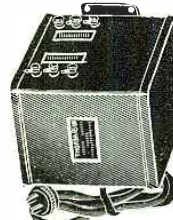

their type T-2900 described above. It has a higher output, and is intended for the "B" power supply of an amplifier using two power tubes of the UX-250 type (small public-address system). The high-voltage winding at full load has a potential of approximately 2 x 750 volts.

AWARDED THE RADIO NEWS LABORATORIES CERTIFICATE OF MERIT NO. 2367.

## VERNIER DIAL



The "Port" type vernier dial, submitted by the Kurz-Kasch Company, Dayton, Ohio, consists of two separate parts; the dial proper and the housing, with the vernier arrangement. The dial proper is 2¾ inches in diameter, made of a white translucent substance similar to galalith, and is calibrated 0-100-0 around its entire circumference. The housing, which is of black molded bakelite, has a very pleasing appearance; it is fastened to the panel with three screws after the dial proper has been mounted on the corresponding shaft. The vernier ratio is approximately 1:5. The translucency of the dial makes possible the use of a panel light behind it.

AWARDED THE RADIO NEWS LABORATORIES CERTIFICATE OF MERIT NO. 2368.

## AUDIO AMPLIFIER

The AP-10 power amplifier submitted by the American Transformer Company, 141 Emmet St., Newark,

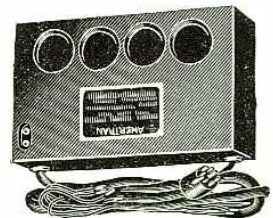

N. J., is a two-stage transformer-coupled audio amplifier, which is designed for connection to the detector stage of a radio receiver; it may be operated either from batteries or from an A.C. power supply system. The first stage is equipped with two sockets; one a standard UX four-prong type and the other a UY five-prong type; it is so wired up that either a 201A-, a 226- or a 227-type tube may be used. The last stage employs two tubes of the UX-210 type operating in a push-pull combination. There are 15 flexible leads which are braided into two cables; one contains two leads for the current supply of the first audio stage, when the four-prong socket is used, and two input leads for the detector. The other cable contains eleven leads, of which the seven supplying the "B" and "C" power are connected to a Yaxley pin plug. The four remaining leads supply filament current to the power tubes and to the first stage when a UY-227-type tube is used. The characteristics of this amplifier with regard to quality and volume of reproduction show a very high degree of perfection.

AWARDED THE RADIO NEWS LABORATORIES CERTIFICATE OF MERIT NO. 2369.

(Continued on page 185)



Conducted by C. W. Palmer

RADIO NEWS readers send in every month an average of 5000 letters asking information on every phase of radio theory, construction and operation. We can only print the five or six replies which are of widest general interest.

Other letters will be answered by mail, if inquirers observe these rules: BE BRIEF; TYPEWRITE OR WRITE LEGIBLY IN INK ON ONE SIDE OF THE SHEET ONLY; ENCLOSE A STAMPED ENVELOPE ADDRESSED TO YOURSELF. Many letters are not readable. Simple questions will be answered free;

those asking for sketches, diagrams, data, etc., should send TWENTY-FIVE CENTS FOR EACH QUESTION: failure to enclose this will cause delay. We cannot answer for this sum questions requiring original research, intricate calculation, or patent investigation; we cannot compare the merits of trademarked apparatus, or give constructional data on apparatus whose makers withhold it. We cannot undertake to answer more than THREE QUESTIONS in each letter. If you inquire concerning a circuit which is not a standard, published one, enclose a diagram to save delay.

**R.F. BOOSTER UNIT FOR A.C.**

(2291) Mr. R. A. Middleton, Seattle, Washington, writes:

(Q.) "In the article on the Booster Unit in the May issue of RADIO NEWS, you specify a plug to be connected to the socket of the detector tube in the set. In the Radiola 17, the detector tube has five prongs instead of four. For this reason, the plug that you specify cannot be used. How can this Booster Unit be connected to this set without rewiring the set, or how can a plug for the five-prong detector tube be made?"

(A.) We have received a great number of letters in reference to the Grimes R.F. Booster Unit. A number of fans desire to use this unit with superheterodyne receivers, and others with alternating-current sets. Naturally, since the Booster Unit is used either with the fundamental or on the "half-wave" or second harmonic of a signal, this Booster Unit cannot be used with the intermediate-frequency amplifier of a superheterodyne. The only way in which the unit can be used with a superheterodyne receiver is to connect it in the first-detector circuit. This method will work quite satisfactorily, especially if one or more stages of radio frequency amplification are employed before the first detector; although with a set of this type, in which a number of radio-frequency amplifier tubes are used, the gain is not very great.

When employing the Booster Unit with alternating-current sets of the tuned-radio-frequency type, it is necessary to use a heater-type (227) tube in the detector and Booster circuits. Fig. Q. 2291 shows the necessary changes in the diagram for employing this type of tube. As you will notice, the lettering and specifications of the apparatus employed are all the same as in the original unit, except for the tube sockets, tube, filament supply and grid return. The grid return is connected to the heater terminal instead of the filament. It will also be necessary to use five connecting wires and terminals because of the extra element in this type of tube.

The method of making the required plug is shown in Fig. Q. 2291A. If you have difficulty

in obtaining a five-prong socket which will fit into the tube base, it may be necessary to take a piece of bakelite or hard rubber and drill holes at suitable points. Prongs should be taken from an ordinary socket and fitted into the tube base to make the contact with the prongs on the tube.

It may be advisable, in some cases, to use a separate twisted lead for the A.C. filament connections; since the capacity between the filament

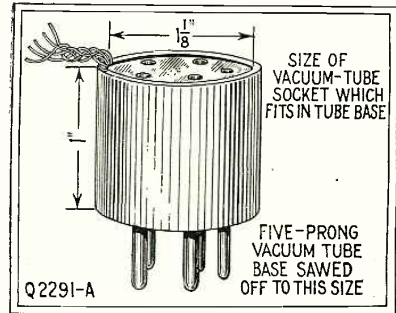

Detail of the 5-prong plug required to connect the Booster Unit with a UY socket.

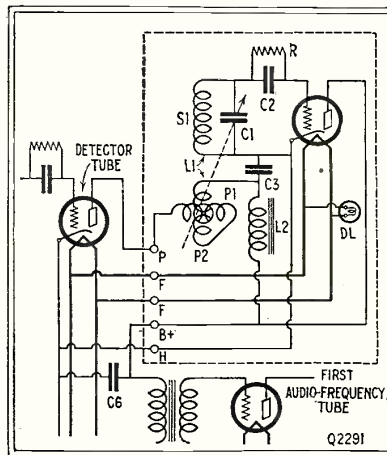

Connections of the Grimes R.F. Booster Unit when used with a 227-type detector tube.

should be twisted together and kept some distance away from the other twisted cable.

We would not suggest the use of the R.F. Booster Unit in A.C.-operated superheterodyne receivers; since the radio-frequency amplification gained by using this unit with a set of this type will not improve the operation to any great extent, and some trouble may be encountered in keeping the A.C. hum at a minimum. In tuned-radio-frequency receivers employing the 227- or a similar heater-type tube in the detector, or heater tubes throughout, it is entirely practical to use this unit if care is taken to keep the filament wires away from the grid and plate leads. The specification of all of the parts employed in this unit and the instructions for using it in a radio set will be found on page 1236 of our May, 1928, issue.

and grid wires may cause A.C. hum. In this case, the three wires marked "P," "B+" and "H" should be twisted together as described in the original article, and the two wires for the filaments

**UNDERGROUND AND UNDERWATER AERIALS**

(2292) Mr. C. Williams, Union, N. J. writes: (Q.) "I would like to obtain information in

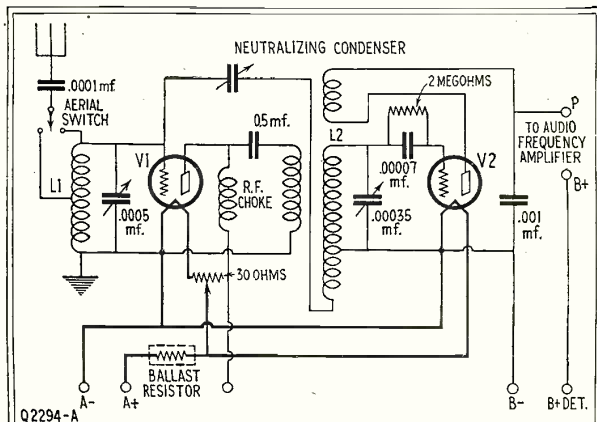

The Browning-Drake tuning unit, as designed for use with ordinary tubes. To use a screen-grid tube in the R.F. stage, it is rebuilt as shown at the right.

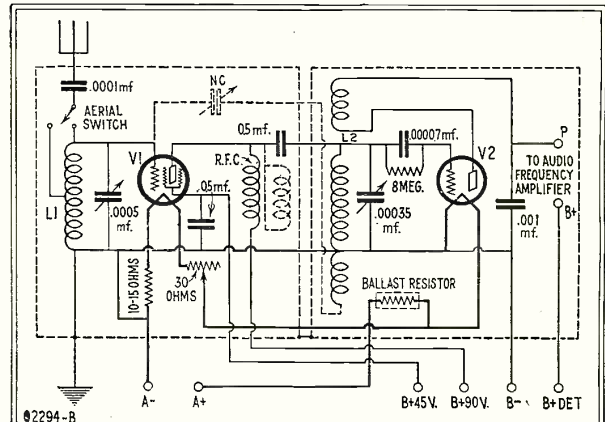

The screen-grid Browning-Drake must be shielded as indicated by the dotted lines above. (See page 189). The neutralizing condenser is eliminated, and the primary of the R.F. coupler unused.

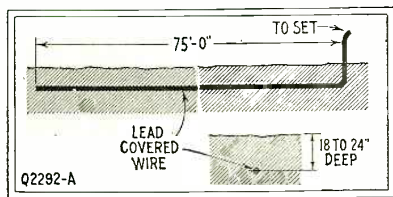

The most efficient form of underground aerial, a straight length, is directional.

reference to the operation and construction of underground and underwater "aerials." I have seen a number of advertisements in recent issues of the radio periodicals advertising antenna devices of this type to reduce static and increase the selectivity of a receiving set. There have been so many "static eliminators" advertised and exploited from time to time, all of which were failures, that I am rather skeptical about the results obtained with an aerial of this type.

(A.) The underground aerial is well known in radio circles and its advantages were proved quite conclusively by tests made during the war by the U. S. Navy Department and several individual experimenters, led by Dr. James Harris Rogers, whose laboratory is located at Hyattsville, Maryland. The tests made by these experimenters showed that the ratio of static and noise to the signal strength was much less than with the ordinary elevated type of aerial. Dr. Rogers arranged aerials of various lengths and depths in all directions around his laboratory, so that by means of switching systems combinations or individual aerials could be used at will. It was found that the underground aerial, when buried in a straight line, is more or less directional, in the plane of its length. It was found that the best wire for use with underground aerial experiments is one with heavy rubber insulation covered by a coating of lead. Seventy-five feet is usually considered about the correct length for an aerial to be used on wavelengths between 150 and 500 meters. Under average conditions, stranded or solid copper wire, about No. 14 gauge, with a good rubber insulation and coated with lead, will be found most suitable for this purpose. The wire should be buried in a shallow trench between 12 and 24 inches below the surface of the ground. An aerial of this type is shown in Fig. Q2292A.

Another type of underground aerial which has been used extensively is one consisting of a number of spirals of lead-sheathed wire buried in a pit about four feet deep and three feet in diameter. An aerial of this type is shown in Fig. Q2292B. The end of the wire should be insulated very carefully by pouring melted paraffin or sealing wax over it and then winding upon it rubber or friction tape to prevent the wax from breaking away. In this way, the end of the wire is made completely waterproof and there is no chance of moisture short-circuiting the wire to the sheath. The spirals should be made with the turns of wire 3 to 4 inches apart, and the smallest diameter should be about 6 inches. The lowest spiral should be placed about 3 feet below the surface of the ground, and a space of 6 to 8 inches should be left between each of the spirals.

The advantages of such an aerial over the first type mentioned are that it is not directional and is much easier to lay. The disadvantages are that the pick-up is much smaller and naturally it is

necessary to use a more sensitive receiver in order to obtain equally satisfactory results.

**Underwater Aerials**

In constructing underwater aerials, the same specifications should be followed for the type of wire, insulation of the end, and length. When the wire is placed in fresh water, it has been found that it can be submerged as deep as 60 feet without an appreciable decrease in signal strength. In salt water, however, it has been found that the signal strength drops off very rapidly when the wire is submerged to any great depth. In making an underwater aerial for operation in salt water, buoys should be fastened to the wire at intervals in order to keep it close to the surface. The underwater aerial is quite satisfactory for portable

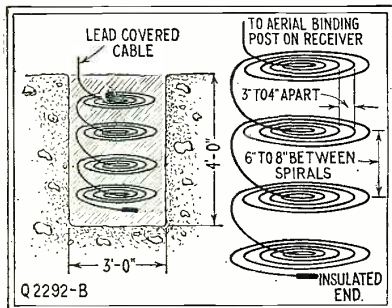

Where room is limited, the underground aerial may be wound in "pancake" layers separated by layers of earth, as shown above.

use, since camps are usually located near a lake or other water supply. If desired, a number of wires may be sunk in a fan-shaped area, and connected together at the lead-in, in order to increase the pick-up. In underwater aerials, it is extremely important that the end of the wire be made watertight; since, if, water enters through the insulation, the wire will be grounded and results obtained will be very poor.

The amount of signal energy received by the ground system is less than that obtained with the average elevated aerial, depending upon the type used, and for this reason it is necessary to use a set with several R.F. amplifier tubes in order to obtain satisfactory volume. The use of an aerial buried in a large circle or semi-circle will overcome the directional effects to some extent; while it has been found that the use of the ground aerial in combination with a "coil" (loop) aerial is of assistance in eliminating interference and strays, since under proper conditions, this combination forms a unidirectional aerial.

The official naval tests from time to time during the war showed some very interesting comparisons between the degree of signal strength as compared to the static when using underground aerials. At New Orleans, for example, it was found possible to carry on steady radio reception from a distant station, with the underground aerial, while a heavy electric storm was directly overhead. It is practically impossible to accomplish anything like this when using a regular elevated aerial, and it would be sometimes rather dangerous to attempt it.

**Types of Receivers**

One of the most important points to remember is that you will not reap the full benefits of static reduction with an aerial of this type, unless you are using a shielded set. If your receiving set does not already have shielded condensers and coils, the set can be shielded by placing aluminum or copper plates all around the inside of the cabinet and then grounding the metal lining. It is important to remember that the lead-sheathed cable must extend up to the set, and also that the ground wire must be a piece of lead-sheathed wire. It will be of advantage, in some cases, also to place the filament and plate supply in a metal-lined box with the lining well grounded. The wires between the power supply and the set, unless they are very short, should be lead-covered and, in any case, all lead sheathing on the wires must be connected to ground. In order to obtain the greatest ratio of signal strength to static, it is best to use batteries to supply the current to the filaments and plates, and to place them in a metal-lined box as mentioned before. (See Fig. Q2292C.)

If a "B" power unit operating from the 110-volt line is used, there is liable to be a feed-back of "strays" through the power unit. This is especially true in country districts where elevated electric-light feed wires branch off from the poles and then proceed to the house. In the city, where most of the electric-light wires are shielded and buried in the street, this effect is much less noticeable, and the "B" power unit can be used quite successfully.

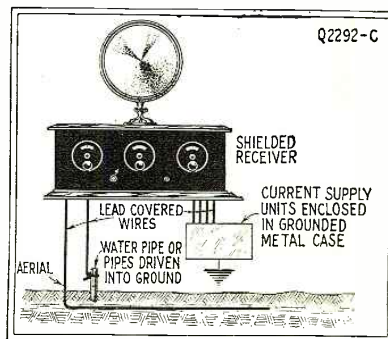

A fully shielded receiver with high amplification should be used, and the lead-in shielded all the way into the set.

**SELECTIVITY**

(2293) Mr. W. M. Butler, Cedar Rapids, Iowa, writes:

(Q.) "In reading articles on the subject of selectivity in radio sets, I have noticed that various authors have different ideas on the subject and very often they are conflicting. For instance, I noticed some time ago, a reference to the use of large condensers and small inductance coils to give the greatest selectivity. Recently, I noticed a statement which said that a large inductance coil and small capacity gave the greatest selectivity. Which is correct?"

(Continued on page 189)

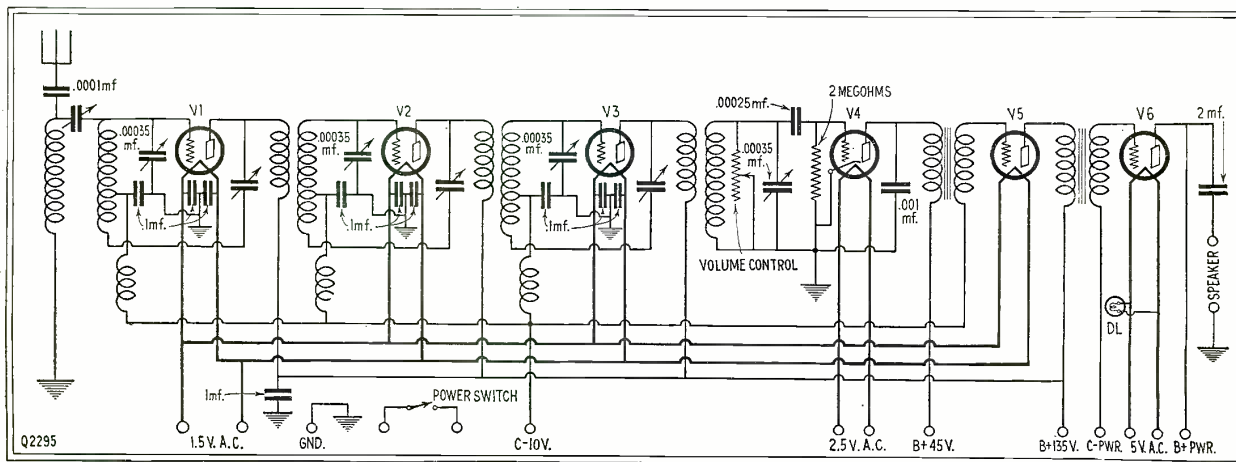

The schematic diagram of the All-American 6-tube electric receiver, showing its special balancing method.



# On the Short Waves

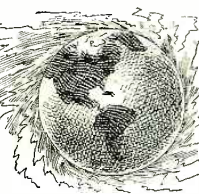

## SHORT-WAVE PHONE STATIONS

(Reported to the Department of Commerce)

Meters	Call
11.00 Nauen, Germany (Also 58 meters)	AGA, AGK, POF, AGB, AGC
14.00 Königswusterhausen, Germany, (Also 36 meters)	AFT, AFJ, AFU
17.40 Bandoeng and Malabar, Java (Saturday, 7:00 a. m. to noon, and as announced—Times reduced to E.S.T.)	ANE, ANH
16.00 Kootwijk, Netherlands, (Wednesday, 9:00 to 11:00 a. m., 40 kw.) (Also 60 meters and other wavelengths)	PCKK, PCLL, PCMM, PCPP, PCRR, PCTT
24.00 Chelmsford, England (8:30, 9:30 a. m., 2:30 p. m. on)	G5SW
28.50 Sydney, Australia (2ME, Sunday, 1:30 to 3:00 p. m.; 2FC week days, 1:30 to 3:30 p. m.)	A2ME, 2FC
29.80 Melbourne, Australia (Sunday, 1:30 to 3:30 p. m.)	A3LO
30.00 Norwegian SS. "Norwegia"	ARFS
30.20 Hilversum, Netherlands	PCJJ
32.00 Sydney, Australia	A2FC
32.00 Johannesburg, So. Africa	JB
32.00 Berne, Switzerland (Mon., Thu., Sat., 3:00 to 4:00 p. m.)	H90C
32.50 Caterham, England (Tues., Thu., Sat., Sun., 1:00 to 2:40 a. m., Sun., 11:00 a. m. to 1:00 p. m.)	G2NM
37.00 Paris, France "Radio Vitus" (Wed., Fri., Sun., 4:00 to 5:45 p. m.)	KAV
39.68 Norddeich, Germany	IIXAN
45.00 Rome, Italy	KCZ
53.16 Riga, Latvia	LL
60.00 Paris, France	LL
61.00 Paris, France	LL

A number of vessels are using phone on 150 to 280 meters: Danish ships on 150, German on 160 and 180, Canadian West Coast ships on 198.60, and numerous others on 200 and somewhat longer waves.

The above list varies somewhat from other detailed reports which have been received; and, of course, changes in their transmissions are frequently made by such stations.

We are glad to receive reports of any short-wave stations received, especially when the wave is determined, by announcement or by wavemeter; or when the locality and call letters are announced. There is, however, no possible way to answer a reader who writes in and asks what and where a station is, without being able to give the wavelength, nationality or location—as some have done.

## CHANGE BY PCJJ

Editor, RADIO NEWS:

Here is something that may interest some short-wave fans. In a letter dated May 17, 1928, received from PCJJ, Eindhoven, Holland, the following facts are given out.

"Our transmissions take place at present every Tuesday from 16—20 GMT, (11 to 3, E.S.T.) every Thursday from 16—20 GMT, (11 to 3, E.S.T.) every Friday from 23—2 GMT, (6 to 9, E.S.T.) every Saturday from 15—18 GMT, (10 to 1, E.S.T.)

"It would be very helpful for us, if you could send us a report now and then, in which kindly state the following:

- "1. Is there any difference in reception since the station's transfer from Eindhoven?"
- "2. Is fading experienced and if so, at what time?"
- "3. What are the signal strength and general qualities of the transmissions?"
- "4. Is the wavelength constant and state general reception conditions?"
- "5. At what time are strongest signals received?"

"Owing to the interference caused by telegraphy transmitters working on about the same wavelength as our station, we have altered our wavelength to 31.4 meters."

No doubt PCJJ will be hard to get now, as 2XAF transmits on 31.4 meters.

RAY C. PAYETTE,  
27 Broadway, Haverhill, Mass.

## AN ELABORATE SYSTEM

Editor, RADIO NEWS:

I am enclosing some pictures of a set that I don't think you ever saw before. I mounted the RADIO NEWS Short-Wave Special that way—each part on a hollow mica tube 8 inches long, to isolate them from each other.

This is how I have rigged up the primary of the antenna coil. On the baseboard I have a quadrant (from a steam gauge) to which the coil is connected by a celluloid rod; from the quadrant I have another celluloid rod to the front panel, with a button to move the coil nearer to or further away from the secondary. This gives a fine tuning combination, as I do not have to put my hand near the set.

I have put up a 50-foot pole and a 150-foot 4-

wire (12-gauge) aerial. Not being able to put a counterpoise the full length of the aerial, I have put in a 50-foot 12-wire one; and in the room where the set is, I have put in a double loop; the upper one 24 inches from the ceiling and 14 inches from the wall, composed of twelve 14-gauge wires spaced 4 inches, and in a horizontal position. The lower one has guides in each corner, so that I can raise it close to the upper one or lower it. There is 450 feet of wire in each one, and in the counterpoise out in the yard there is .600 feet of wire. I have a ground also of two copper cables of 350,000 mils each, down nine feet, and three copper tapes  $\frac{3}{4}$  x  $\frac{1}{32}$ -inch down five feet. Each of these grounds has its own hole, and all connections are soldered and come to a common lead-in,  $\frac{1}{2}$  feet from set to ground.

I have tried combinations of every possible hook-up of antenna system. Using the inside loops I get fine, clear, static-free reception, but not so much volume. Using the outside antenna, I can get reception on the RCA 100A loud speaker, but it does not fill the room with music by a long ways. Sitting three to five feet away, one can hear and understand very well.

Now, after all this, tell me why I can get only WGY on the short waves? There are several other broadcast stations, but all I get is the carrier waves. I am not kicking, but just asking if you know why.

PARKER P. BALDWIN,  
Casilla 115, Tocopilla, Chile.

(More favorably-situated fans will admire the determination and resourcefulness which led Mr. Baldwin, at the foot of the Andes Mountains, in a location evidently none too favorable, to go to such lengths in the endeavor to secure good radio reception. We believe that he will yet succeed, especially since short-wave broadcasts are increasing; and a location impenetrable from some directions may be reached from others by the right waves.—EDITOR.)

## STATION HARMONICS

Editor, RADIO NEWS:

Tonight at about 8:15 o'clock I received WGY on my short-wave set. As this is the first time that I have ever received a station over such a distance I am naturally a bit enthused.

I am using a home-constructed set of two tubes, one of them an audio amplifier. The circuit is regenerative, and uses a fixed tickler and condenser (variable) for oscillation control. This circuit appeared in THE EXPERIMENTER, but I got it out of the October issue of RADIO REVIEW for 1925.

Fading was very noticeable. At times the signal faded out entirely, but it always came back again. The volume was very good, considering that I am using 199 tubes with 45 volts of "B" battery. At first I thought I had a local station.

Although the day was warm, there was no static at all. Static has been bothering me a little, but there was no trace of it tonight.

I also received KSL at Salt Lake City on the same set. This station was not listed as having a short-wave broadcast outfit but they came in at about 33 meters on my set. I have written to the station but have not received a reply as yet. I shall be glad to give you any further data on short-wave stations that I receive.

LEWIS RAINS,  
R. R. 9, Seattle, Wash.

(In addition to the short-wave broadcasts deliberately planned, broadcast stations emit harmonics, though with energy comparatively feeble, which may be heard in short-wave receivers. Twelfth, thirteenth, and even higher harmonics may be heard at short distances; and the lower harmonics over a wide area, even when the fundamental carrier is not detectable. Mr. Rains may have heard the ninth harmonic of KSL at this distance.—EDITOR.)

## UNDER THE MIDNIGHT SUN

Editor, RADIO NEWS:

I wish to say a few things about short-wave or intercontinental broadcasting. I live in central Yukon Territory in Canada, next to Alaska, at 64  
(Continued on page 188)

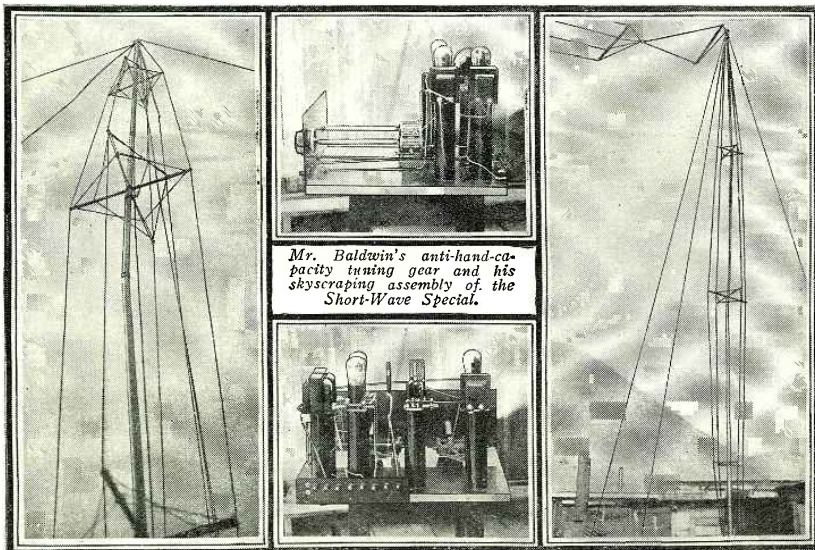

Mr. Baldwin's anti-hand-capacity tuning gear and his skyscraping assembly of the Short-Wave Special.

Mr. Baldwin's mast carries both a vertical and a horizontal aerial. Each wire is fully insulated from its supports; "I have gone to extremes," he writes, "in soldering and insulating."

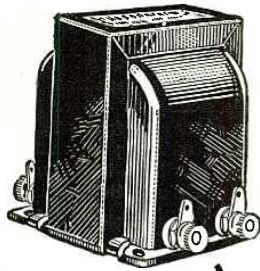

## In Most of The Better Radio Receivers

Watch dogs of tone quality safeguarding the musical reproduction of broadcast programs, Thordarson Audio Transformers do their part in making real musical instruments of hundreds of thousands of receiving sets annually.

Among leading set manufacturers, Thordarson transformers have long been recognized for their fidelity of reproduction. Today their use is so universal that it is difficult to find a dealer who does not sell at least one make of receiver so equipped.

Try this simple experiment. Ask your dealer for a demonstration of his receivers. Pick out the instrument with the most natural reproduction, and then look inside the cabinet. You will find, in the majority of cases, Thordarson amplifying and power supply transformers.

You will realize that it is wise to specify Thordarson amplification when buying your receiver, for the manufacturer who is far-seeing enough to equip his sets with Thordarson transformers, may be depended upon to have the balance of his instrument in keeping with this high standard.

*new!*



THORDARSON  
**R-300**  
AUDIO TRANSFORMER

A superior audio transformer that will satisfy the most critical musical ear. The high impedance windings of the R-300 are wound on a core of D-X Metal, a recent development of the Thordarson laboratory. This new core material has an exceedingly high A.C. permeability, and an inductance that is 50% greater than that of the highest grade silicon steel. In performance, this transformer responds exceptionally well to the lower frequencies and provides the same degree of amplification to the diapason of the grand organ as to the note of the flute. Ratio 3:1. Dimensions, 2½" x 2½" x 3" high. Weight, 2 lbs. Price, \$8.00.

# THORDARSON

RADIO TRANSFORMERS

*Supreme  
in  
musical performance*

**THORDARSON ELECTRIC MANUFACTURING CO.**  
*Transformer Specialists Since 1895*  
**WORLD'S OLDEST AND LARGEST EXCLUSIVE TRANSFORMER MAKERS**  
*Huron and Kingsbury Streets - Chicago, Ill. U.S.A.*

# Tone REPRODUCTION



## As you like it

### BUILD YOUR OWN LOUD SPEAKER

"How to Build MODERN LOUD SPEAKERS," by Clyde J. Fitch, is a complete history of Radio acoustics. Every phase of Loud Speaker design and construction is fully and accurately explained. The many and various methods of attaining true tone reproduction are treated in a clear and concise manner. All types of Loud Speakers, the Exponential Horn, the Cone, the Piezo Electric Speakers, Roll Type Speakers, in fact, every method that has been used to produce clear, audible signals is most thoroughly covered.

The good and bad points of each development are honestly and unbiasedly treated. This is unquestionably one of the most comprehensive treatises on the subject ever written.

#### BUILD YOUR OWN LOUD SPEAKER

This valuable book contains full constructional data and diagrams for the building of the Loud Speaker best fitted to give you maximum satisfaction with the particular receiving circuit that you employ.

52 pages—fully illustrated—6' x 9'

25c

THE COPY

ON ALL NEWSSTANDS OR WRITE DIRECT

THE CONSRAD CO., INC.

230 Fifth Ave. New York, N. Y.

CONSRAD COMPANY, INC.  
230 Fifth Ave., New York, N. Y.

Gentlemen: Enclosed find 25c. Kindly send me a copy of HOW TO BUILD MODERN LOUD SPEAKERS

Name.....

Address.....

City.....State.....

## Some Inside Facts About "B" Batteries

(Continued from page 135)

back to the days of the "voltaic pile," the original form of battery, which was composed of strips of alternating metals, separated by cloth wet with salt water. It is interesting to note that the radio adaptation of this battery is its first commercial use since its advent about 150 years ago!

This particular battery, instead of using the cylindrical cells usual in the others, has its elements arranged in tiers forming two cubes which, when housed within a

tween the two piles and the connections to the binding-post terminals on the outside.

The difficulty, of course, lies in the possibility of leakage from one cell to the next and of a resulting internal short circuit; but this has been taken care of satisfactorily by the adoption of a dam along the edges of the plates. This is also treated to prevent seepage.

In this type of cell, it is apparent that every particle of space is used and, since

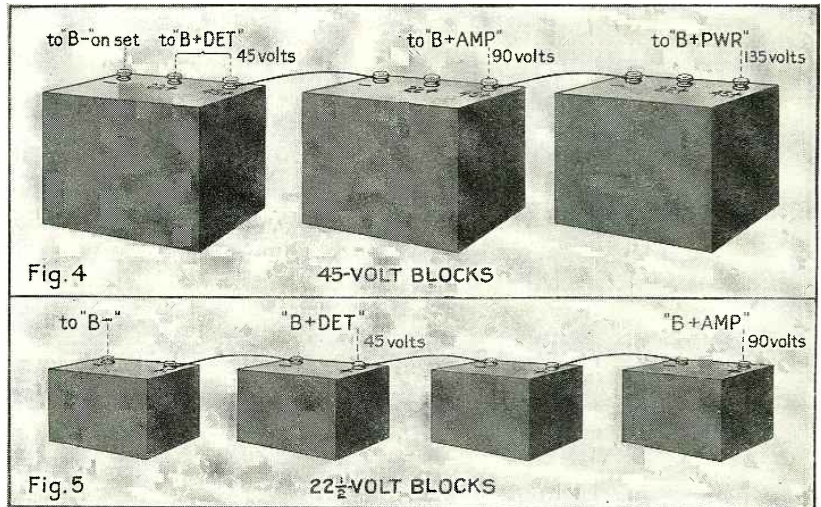

Batteries, whether in 22½- or in 45-volt blocks, are tapped in 22½-volt units of 15 cells each.

cardboard container, form a battery of standard size. See Figs. 2 and 3. The elements are of practically the same materials used in the ordinary battery, but are of different shape. The carbon element, for example, is painted in a thick layer upon the zinc. Next below comes a porous separator containing the electrolyte, and then the mixing block which comprises the manganese dioxide and other materials usually used at this point. Below this continues a series of similar carbon and zinc elements, until the entire assembly of the required number of plates is in place. This method of construction does away with all internal connections except three—that be-

the zinc no longer acts as a container, the battery will continue to render service even after the zinc is eaten to the appearance of old lace. The fact that interconnections are also eliminated adds to the reliability and length of life of such a cell.

With ordinary care, it will be found that good dry "B" batteries will stand up and last for a considerable length of time. The fact that all kinds of so-called "eliminators" are now available does not, necessarily, mean that radio batteries will pass out of the picture. In fact where first cost is the primary consideration, it is apparent that the humble dry battery is still supreme.

## The Zero-Reactance Plate Circuit

(Continued from page 153)

the circuits out of balance and produce oscillations. Locking all the condensers together, making a single-control set out of it, helped matters considerably, but did not entirely cure them. The slight tendency to oscillate that still remained could be damped out very easily by placing a few ohms of resistance in the antenna circuit. The trouble could also be cured very nicely by employing a neutralizing scheme in the first stage; but this, of course detracted from the simplicity of the arrangement.

#### DESIGN OF COILS

Before closing this article, it will be of interest to explain how the coils were made. There were two styles tried out; in both

cases ordinary bakelite tubing was used. In the one case we had a single-layer double-wound coil. The primary and secondary were wound at the same time, the first turn being a primary turn, the second a secondary turn, the third a primary turn, and so on. The main disadvantage of this style was the length of the coil. In the second case, the primary was first wound on the tubing, and then the secondary was wound directly on top of the primary. In each case, both the primary and secondary windings had the same number of turns; and it was interesting how much smaller the secondary was in comparison with the usual secondary employed in the ordinary circuits. This is because of the large mutual inductance.

# The Radio Book You Want! "MODERN RADIO RECEPTION"

By CHARLES R. LEUTZ

## A Complete Ready Reference Educator

250 ILLUSTRATIONS **\$3.00** MODERN RADIO RECEPTION 384 Pages—250 Illustrations Fully Bound—6 x 9 inches *Three Dollars Complete* 384 PAGES

### PRACTICAL HELPS IN HANDY FORM

Diagrams, charts, graphs, illustrations, tables, easily read text make difficult problems easy.

"Modern Radio Reception" is a good book, explaining all important subjects on radio reception and radio receivers, written in a clear manner easily understood by anyone. It is not too technical, and the mathematical examples are confined to simple problems.

Considerable information is given on the operation and care of radio receivers and accessories. The most powerful receiver for broadcast reception in the world, the Transoceanic Silver Ghost, is described in detail. Short Wave Reception is also covered, as this is one of the coming things in world-wide broadcast reception.

As this handy book covers the entire field of broadcast reception in such a clear and complete manner, it will prove

to be a practical daily help to both the student and professional worker, as well as the broadcast listener.

Professional and Student Radio Engineers find "Modern Radio Reception" a Time and Money Saver. The book that every Broadcast Listener should own.

Here is an up-to-date, quick ready reference and text book on radio reception. It is the only up-to-date book exclusively on radio reception. Such late improvements as A.C. Tubes, Shielded Grid Tubes, "A" Eliminators, Push Pull Power Amplifiers, 400-volt "B" Eliminators, etc., are covered in detail.

All the different important subjects relating to radio reception are covered in an interesting and clear manner. By reading this book you can probably save the price of the book many times, the suggestions will save you money and enable you to secure the best results in your radio receiving work.

### A RADIO EDUCATOR

This single volume contains all the practical up-to-date radio receiving information that the professional radio worker, broadcast listener, student, or amateur needs. "Modern Radio Reception" is fully bound, size 6 x 9 inches, 384 pages, over 250 illustrations, including many graphs and circuit diagrams. It is nicely bound, a book that will look well on your library table, furnishing the means of a thorough knowledge of radio reception by spare time reading and study.

### Some of the Subjects Covered

- |                          |                           |                                   |                          |
|--------------------------|---------------------------|-----------------------------------|--------------------------|
| Antennae                 | Meters                    | Tungar Chargers                   | List Short Wave Stations |
| Counterpoise             | Oscillators               | Coupling Methods                  | Universal Transoceanic   |
| Ground                   | Audibility Meter          | "A" Eliminators                   | Super-Heterodynes        |
| Condenser Plate Shapes   | Capacity Bridges          | "B-C" Eliminators                 | Consoles                 |
| Acoustic Chart           | Mechanical Oscillators    | Power Amplifiers                  | Universal Silver Ghost   |
| Transmission Units       | Ammeter                   | Western Electric Super-Heterodyne | Super-8                  |
| Dynamic Loud Speakers    | Beat Oscillator           | Grebe Synchrophase                | Universal Plio-6         |
| Cone Loud Speakers       | Amplifier Test Set        | Norden Hauck Super-10             | Wave Antenna             |
| Dynamotors               | Push Pull Amplifiers      | Frequency Changers                | Radio Servicing          |
| Inductances              | Vacuum Tube Bridge        | Vacuum Tubes                      | Tube Characteristics     |
| Condensers               | String Oscillograph       | Ballast Tubes                     | World Time Chart         |
| Shielding                | Piezo Electric Oscillator | A.C. Tubes                        | Overloading Tubes        |
| Resistors                | Synchronous Motor         | Radio Standards and Definitions   | Audio Amplifiers         |
| D.C. Battery Eliminators | Vacuum Tube Reactivation  | Radio Symbols                     | Shielded Grid Tubes      |
| Wavemeters               | Decade Bridge             | Short Wave Reception              | Radio Amplifiers         |

### FREE EXAMINATION

Effective immediately, free examination will be allowed. Your money refunded if the book is returned within 7 days. Postpaid to any address in the United States.

USE THE COUPON ATTACHED TO GET THIS FREE OFFER

C. R. LEUTZ, Inc., 195 Park Place, Long Island City, New York.

Gentlemen:

- Please send C.O.D. one copy 1928 Edition of Modern Radio Reception.
- I enclose \$3.00. Please send postpaid one copy Modern Radio Reception.

Note: In either case, I am allowed seven days Free Examination. If found unsatisfactory, full price of \$3.00 is to be refunded upon return of book.

Name.....  
Address.....  
City..... State.....

**Guaranteed**  
**Socket Power**  
**Unit—\$13.75**



**90-Day Guarantee**  
 An absolutely unequalled value! We want you to test the World "A" Socket Power Unit and compare it with any other of two or three times the price. Try for ten days at our risk. Then if you are not convinced that it is unsurpassed as to quality and wonderful results, purchase price will be refunded in full. Operates on 50 or 60 cycles at 110 volts A. C. Highest quality Westinghouse electrical equipment. No hum or noise. Approved by Radio News Laboratories and other leading Authorities.

**Send Order Today** Just write address on a slip of paper—pin a one dollar bill to it and mail today. We will ship same day order is received for \$12.75 C. O. D. 5% discount for cash with order. Remember you are the judge and are fully protected—so send order NOW.

**only \$1.00 Down Balance C.O.D.**

**WORLD BATTERY COMPANY**  
 1241 S. Michigan Avenue  
 Dept. 60 Chicago, Illinois

Station W. S. B. C., owned and operated by World Battery Company

It is hardly necessary to state the results obtained with this receiver, except that it was very sensitive and tuned very sharply. It was possible to use "C" battery bias on all the R.F. amplifier tubes (all of which were 201A's) and, when using a "C"-battery detector, the interesting diagram of Fig. 4 resulted.

The same bias was used for the R.F. amplifiers and the detector. Each stage was individually shielded and the shielding or ground was made 3 volts negative with respect to one leg of the filament by connecting this side of the filament to "C+" and the shield (or ground) to "C-3." The "B-," "A-" and "C+" were connected together, with 90 volts on the R.F. amplifier plates and 45 volts on the detector. The first audio stage was also worked on 90 volts plate. The leg of the filaments which was made "C+" was joined to ground through a 001-mf. by-pass condenser, as shown in Fig. 4. The plate voltages of the R.F. amplifier tubes were fed through R.F. choke coils—the familiar shunt-feed arrangement. No by-pass condensers were necessary in the plate circuits, as all of the tuned circuits were connected directly to ground.

As regards the selectivity of this receiver, it may be pointed out that there were seven tuned circuits; viz., four input circuits and three output circuits. Naturally, the output circuits tuned broadly on account of the large plate-to-filament resistances in series with the primary coil and condenser; but, nevertheless, this tuning contributed somewhat to the selectivity. The power output, as well as sharpness and sensitivity, was all that could be desired. The drain on the "B" supply was very small, not exceeding 26 milliamperes for the entire set. This was due to the bias on the R.F. tubes, as well as on the other tubes.

**BIG EUROPEAN STATIONS**

The super-power station at Lahti, Finland, recently illustrated in these pages, is operating on 1525 meters. Czechoslovakia is about to erect a new 50-kilowatt station near Prague.

**AMAZING STORIES** IN OUR AUGUST ISSUE:

**The Skylark of Space**, by Edward Elmer Smith, in collaboration with Lee Hawkins Garby. (A Serial in Three Parts) Part I. Much conjecturing has been done on the far-reaching effects and possibilities of the energy contained in an atom, if it ever could be released. The discovery of a method, very probably, will be accidental. The first instalment is chock-full of intense moments and thrilling detail.

**Armageddon—2419 A.D.**, by Philip Francis Nowlan. While enormous strides were made during the World War, both in the type of mechanical warfare and in the uses of poisonous gases, the limit has not been reached. In this story, the author tells some amazing things, which are scientifically correct. It contains a number of interesting prophecies, many of which are sure to come true.

**The Perambulating Home**, by Henry Hugh Simmons. This is the fourth of the series of "Hicks' Inventions with a Kick." It is funnier and more thrilling than the preceding stories and gives us some very startling new ideas.

**The Head**, by Joe Kleier. Recent experiments in Germany have proved that it is possible to decapitate insects and transplant the heads from one to another, with no obvious harm to the insects, after the wounds are healed. If it can be done with insects, why not with animals, and perhaps with human beings, sometime in the future?

**And Others.**

**WHAT SHOULD A RADIO DEALER READ?**

**W**HAT should a radio dealer read in order to keep informed of the growth inside the industry? Where can he obtain this information in a clear and concise manner that will answer authentically just what he desires to know and not cause him to waste his valuable time in wading through seemingly endless pages of inconsequential trade notices and announcements?

In plain words, where can a radio dealer find a trade paper that is a *trade paper* and not just a medium for FREE publicity. A cold analysis shows the following to be undeniably a fact.

**RADIO NEWS DEALERS PERSONAL EDITION** covers the radio trade like a blanket. It goes to over twenty-seven thousand hand-picked radio dealers located throughout the entire country.

**RADIO NEWS DEALERS PERSONAL EDITION** is bound under one cover with the foremost magazine of radio—**RADIO NEWS**. Thus the dealer obtains the leading consumer magazine at no cost, absolutely FREE.

**RADIO NEWS DEALERS PERSONAL EDITION** is edited by the entire radio trade. Every important trend is reviewed by those actively engaged in some phase of the industry, not by professional writers who must depend more on "a play on words" than actual experience in order to write with any degree of intelligence.

**RADIO NEWS DEALERS PERSONAL EDITION** carries no trade notices to the effect that "John Jones, formerly of Smith Radio, is now with the John Doe Co." Ours is a magazine for the whole trade and not for the individual.

**RADIO NEWS DEALERS PERSONAL EDITION** naturally inherits the background of **RADIO NEWS**, that of the leader.

Where else can a dealer find another paper that has all of these attributes? Speaking from the standpoint of experience and in full cognizance of the subject in question, we can honestly state—nowhere.

Wise dealers all over the country are filling in this coupon and returning it to us. Why not do likewise? By mailing in this coupon now you will obtain **RADIO NEWS DEALERS PERSONAL EDITION**, together with a free copy of **RADIO NEWS**, at the special subscription rate of \$1.50 for the year. (Regular rate \$2.50.) Mail this coupon NOW.

**EXPERIMENTER PUBLISHING CO. Inc.**  
 230 FIFTH AVE., NEW YORK, N. Y.

**ATTACH YOUR LETTERHEAD THIS IS IMPORTANT**

**EXPERIMENTER PUBLISHING CO., Inc.**  
 230 Fifth Avenue, New York, N. Y.

Gentlemen:  
 I desire to take advantage of your special subscription offer and am enclosing \$1.50. Kindly send me **RADIO NEWS DEALERS PERSONAL EDITION** for one year, beginning with the current issue

Name.....  
 Address.....  
 City.....State.....

**AMERTRAN PF-250**  
**Power Transformer**  
 for  
**UX 250 Power Tubes**

A husky transformer built for doing the job, not for looks. The PF-250 is rated at 1200-600 volts plate, 7½ volts power tube, 7½ volts rectifier tube filament. Center taps are provided on each of the filament windings. Continuous rated capacity of plate windings, 160 MA., continuous rated capacity of each 7½ volt winding, 3 Amperes. DC plate output with two UX 281's full wave, up to 450 volts with sufficient excess for "C" Bias.

Ask for Bulletin No. 1033 describing fully the PF-250.

Price, each—\$30.00  
 Slightly higher West of Rocky Mountains

**American Transformer Co.**  
 Transformer Builders for more than 28 Years  
 260 Emmet St., Newark, N. J.

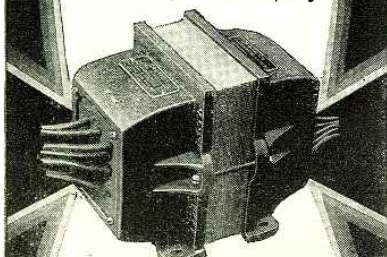



# WHOLESALE PRICES

for Dealers, Community Set Builders, General Repairmen and Agents!



New 75 HOOKUPS  
500 ILLUSTRATIONS

Be sure to get this great 144-page book with net prices to the radio trade.

Radio Specialty Company is radio's oldest radio parts mail order house in the country, and the new confidential prices on standard radio merchandise are the lowest of any radio house.

We are ready now to appoint additional agents in all parts of the country. If you are contemplating making big money in radio merchandise, be sure to get in touch with us at once.

## Television is here!

Radio Specialty, as usual, is first with all new things. Send at once for free booklet for lowest prices on all television parts which have been put on the market so far. (If you have Catalog No. 18, just ask for the Television Supplement.)

THIS 144 PAGE RADIO CATALOGUE FREE

### BUY from Radio's Oldest Mail Order House!

We are the oldest established, exclusive radio mail order house in the country. All orders are positively shipped within twenty-four hours; quick, prompt, courteous service. We carry a larger variety of radio parts, radio instruments, accessories and radio findings than any other radio house in the country.

### "RASCO" has it

ANYTHING IN RADIO

You will find in Catalog No. 18 the largest assortment of radio merchandise in this country. Radio Specialty carries more radio parts and radio material than any other house in the country. You will find in this catalog positively the largest variety of radio merchandise.

If you are in need of certain small radio parts that other radio and mail order houses do not bother to carry, get the Rasco Catalog and you will find the small parts there, anything from a screw to copper ribbon, telephone diaphragms, as well as thousands of other small radio findings. Just to mention a few:

Lugs, nuts, jacks, plugs, all kinds of knobs, cords, panels, screws, sliders, washers, selenium, tinfoil, switches, crystals, cap nuts, Litz wire, cord tips, brass rods, resistances, binding posts, switch parts, carbon balls, switch points, lock washers, carbon grains, ground clamps, metal pointers, insulated tubing, low melting metal, antenna connectors, as well as thousands of other articles. We carry the Largest Variety of Small Radio Parts in the World, BUT We also carry All Standard Radio Merchandise.



## Radio Specialty Co.



98W PARK PLACE, NEW YORK

# The Radio Beginner--A Two-Tube Reflex

(Continued from page 138)

## Build THE STROBODYNE

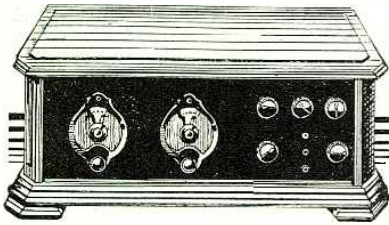

### The Greatest Super Heterodyne

A NEW and revolutionary principle is embodied in the Strobodyne. This new principle is based on what is known as the "Stroboscopic Phenomenon." It is the application of this phenomenon to the basic principles of Super-Heterodyne construction that has placed the STROBODYNE so far ahead of all other Super-Heterodynes. The STROBODYNE employs eight tubes and is a marvel from the standpoint of selectivity, accurate tone reproduction and as a DX set.

Of course CONSRAD, the oldest and original radio pattern publishers, were given the task of publishing complete instructions for the building of an efficient STROBODYNE RECEIVER. In designing the best and most comprehensive instruction material, they have excelled. The STROBODYNE PATTERN BY CONSRAD contains four full size blueprints and a special 16-page instruction booklet that answers fully every question on STROBODYNE construction.

Write today—Get a full set of STROBODYNE patterns from CONSRAD—You will be more than satisfied with the results that a STROBODYNE RECEIVER assures you.

Full constructional data

only **50c**

THE CONSRAD CO., Inc.  
230 FIFTH AVE., NEW YORK, N. Y.

THE CONSRAD CO., INC.,  
230 Fifth Ave., New York, N. Y.

Gentlemen: Kindly send me a full set of blueprints and all data required for building the efficient STROBODYNE RECEIVER. Enclosed find 50c. to cover.

Name.....

Address.....

City..... State.....

ened in place with wood-screws. The coils are mounted on opposite sides of the baseboard, 2 inches from the front and 1/4-inch from the edge. L1 is mounted in a horizontal position on the left side of the baseboard and L2 is placed in a vertical position on the right side. One tube socket is mounted in the rear of each coil. They are located one inch from the nearest edge and 1/4-inch from the rear of the board. The two A.F. transformers (T1 and T2) are mounted 1 1/4 inches apart and 1/2-inch from the rear of the base. When located in this position, each is adjacent to one of the tube sockets. The R.F. choke coil (L3) is mounted in the center of the base 2 3/4 inches from the front edge, and the filament-ballast resistors (R1 and R2) are mounted on each side. The last part to mount on the baseboard is the adjustable condenser (C3), which is placed on the left rear edge of the base. The pictorial wiring diagram shows the approximate position of the various pieces of apparatus, but their size has been reduced in some cases to show the wiring more clearly.

After the parts have been mounted on the baseboard, the front panel and binding-post panels may be screwed in place. Two wood-screws are used for the front panel and three screws for the binding-post panel. The panel for the crystal detector (D) may also be mounted at this time. It is held in

place by the binding posts of the A.F. transformers (T1 and T2), as shown.

#### WIRING INSTRUCTIONS

The wiring of the receiver is very simple. All wires are above the base, and flexible insulated wire is used for the purpose. If the builder is not proficient at soldering, the connections may be made with the binding posts on the various parts; but it is always more satisfactory to solder the wire direct to the soldering lug wherever possible.

It is always best to start with the filament wiring. First, one terminal of the battery switch (SW) should be connected by a wire to the binding post marked "A—B—C+" and the other terminal of the switch with one terminal of each of the filament-ballast units (R1 and R2). The other terminal of ballast unit R2 should be connected with the "A—" terminal (one of those marked "F") of the tube socket V1, and the free terminal of unit R3 with the "A—" terminal of the tube socket V2. To complete the filament wiring, the "A+" terminals of the tube sockets (V1 and V2) should be connected with the "A+" binding post. This part of the circuit may now be tested by inserting tubes in the two sockets and connecting a 6-volt "A" battery to the two "A" binding posts. The tubes should light when

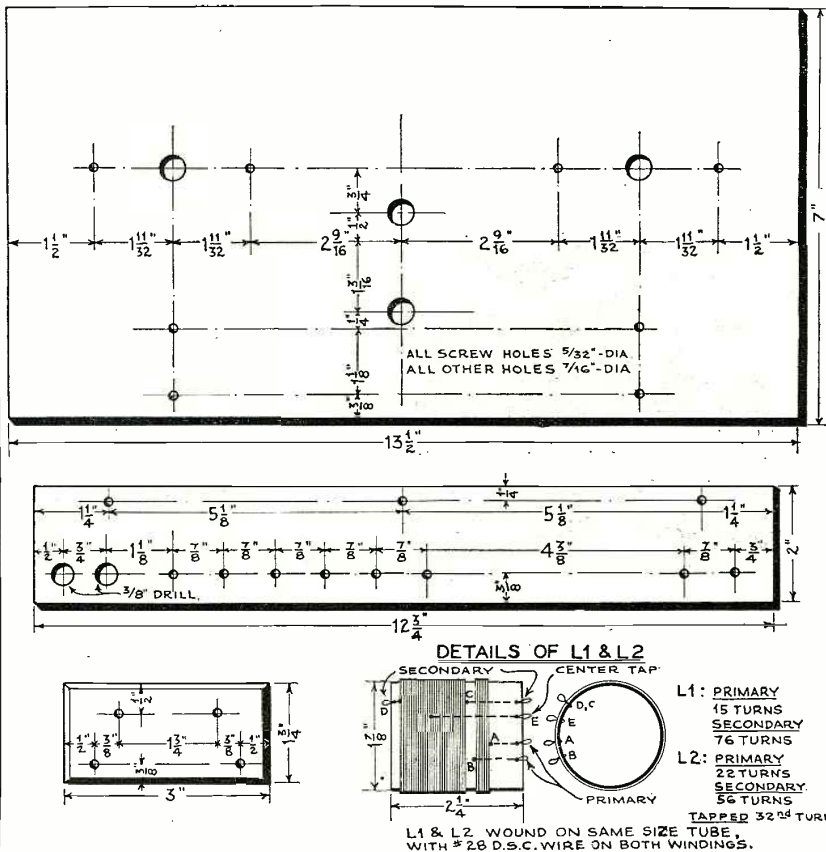
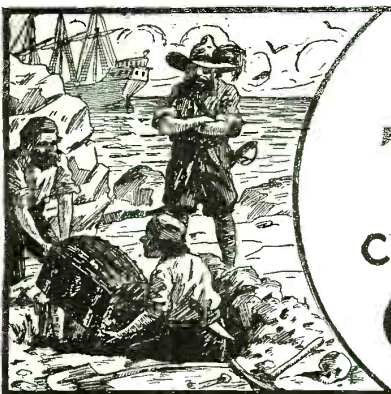

Fig. 3. Panel and coil details for the Two-Tube Reflex Receiver.



# BURIED TREASURE can still be found in CHEMISTRY



## Good Chemists Command High Salaries

You can make yourself independent for life by unearthing one of chemistry's yet undiscovered secrets.



**T. O'CONOR SLOANE, A.B., A.M., LL.D., Ph.D.**  
Noted Instructor, Lecturer and Author. Formerly Treasurer American Chemical Society and a practical chemist with many well-known achievements to his credit. Not only has Dr. Sloane taught chemistry for years, but he was for many years engaged in commercial chemistry work.

Do you remember how the tales of pirate gold used to fire your imagination and make you want to sail the uncharted seas in search of treasure and adventure? And then you would regret that such things were no longer done. But that is a mistake. They *are* done—today and everyday—not on desert islands, but in the chemical laboratories throughout your own country. Quietly, systematically, the chemist works. His work is difficult, but more adventurous than the blood-curdling deeds of the Spanish Main. Instead of meeting an early and violent death on some forgotten shore, he gathers wealth and honor through his invaluable contributions to humanity. Alfred Nobel, the Swedish chemist who invented dynamite, made so many millions that the income alone from his bequests provides five \$40,000 prizes every year for the advancement of science and peace. C. M. Hall, the chemist who discovered how to manufacture aluminum, made millions through this discovery. F. G. Cottrell, who devised a valuable process for recovering the waste from flue gases, James Gayley, who showed how to save enormous losses in steel manufacture, L. H. Bakeland, who invented Bakelite—these are only a few of the men to whom fortunes have come through their chemical achievements.

### What Some of Our Students Say of This Course!

I have not written since I received the big set. I can still say that it far exceeded my anticipations. Since I have been studying with your school I have been appointed chemist for the Seranton Coal Co., testing all the coal and ash by proximate analysis. The lessons are helping me wonderfully, and the interesting way in which they are written makes me wait patiently for each lesson.—**MORLAIS COUZENS.**

I wish to express my appreciation of your prompt reply to my letter and to the recommendation to the General Electric Co. I intend to start the student engineering course at the works. This is somewhat along electrical lines, but the fact that I had a recommendation from a reliable school no doubt had considerable influence in helping me to secure the job. **H. VAN BENTHUYSEN.**

So far I've been more than pleased with your course and am still doing nicely. I hope to be your honor graduate this year.—**J. M. NORRUS, JR.**

I find your course excellent and your instruction, truthfully, the clearest and best assembled I have ever taken, and yours is the fifth one I've studied.—**JAMES J. KELLY.**

From the time I was having Chemistry it has never been thus explained to me as it is now. I am recommending you highly to my friends, and urging them to become members of such an organization.—**CHARLES BENJAMIN.**

I shall always recommend your school to my friends and let them know how simple your lessons are.—**C. J. AMDAHL.**

I am more than pleased. You dig right in from the start. I am going to get somewhere with this course. I am so glad that I found you.—**A. A. CAMERON.**

I use your lessons constantly as I find it more thorough than most text books I can secure.—**W. M. H. TIBBS.**

Thanking you for your lessons, which I find not only clear and concise, but wonderfully interesting. I am.—**ROBT. H. TRAYLOR.**

I received employment in the Consolidated Gas Co. I appreciate very much the good service of the school when a recommendation was asked for.—**JOS. DECKER.**

## Now Is the Time to Study Chemistry

Not only are there boundless opportunities for amassing wealth in Chemistry, but the profession affords congenial employment at good salaries to hundreds of thousands who merely follow out its present applications. These applications are innumerable, touching intimately every business and every product in the world. The work of the chemist can hardly be called work at all. It is the keenest and most enjoyable kind of pleasure. The days in a chemical laboratory are filled with thrilling and delightful experimentation, with the alluring prospect of a discovery that may spell fortune always at hand to spur your enthusiasm.

### You Can Learn at Home

To qualify for this remarkable calling requires elaborate specialized training. Formerly it was necessary to attend a university for several years to acquire that training, but thanks to our highly perfected and thorough system of instruction, you can now stay at home, keep your position, and let us educate you in Chemistry during your spare time. Even with only common schooling you can take our course and equip yourself for immediate practical work in a chemical laboratory. Dr. Sloane gives every one of his students the same careful, personal supervision that made him celebrated throughout his long career as a college professor. Your instruction from the very beginning is made interesting and practical, and we supply you with apparatus and chemicals for performing the fascinating analyses and experimental work that plays such a large part in our method of teaching, and you are awarded the Institute's official diploma after you have satisfactorily completed the course.

### Easy Monthly Payments

You don't have to have even the small price of the course to start. You can pay for it in small monthly amounts—so small that you won't feel them. The cost of our course is very low, and includes everything, even the chemistry outfit—there are no extras to buy with our course. Our plan of monthly payments places a chemical education within the reach of everyone. Write us and let us explain our plan in full—give us the opportunity of showing you how you can qualify for a highly trained technical position without even giving up your present employment.

### MAIL COUPON FOR FREE BOOK

Your name and address on the coupon will bring you by return mail our interesting free book, "OPPORTUNITIES FOR CHEMISTS," and full particulars about the course and what it will do for you. You owe it to yourself to get this book. Send the coupon right now while it is fresh in your mind. Or just write your name and address on a postal and mail it to us. But whatever you do, act today!

**DON'T WAIT—MAIL COUPON NOW!**

NAME .....

ADDRESS .....

CITY .....

STATE .....



### Experimental Equipment Furnished to Every Student

We give to every student, without additional charge, this chemical equipment, including fifty-two pieces of laboratory apparatus and supplies, and fifty-two different chemicals and reagents. These comprise the apparatus and chemicals used for the experimental work of the course. The fitted heavy wooden box serves not only as a case for the outfit but also as a useful laboratory accessory for performing countless experiments.

## CHEMICAL INSTITUTE OF NEW YORK, Inc.

Home Extension Division 8  
16-18-R-E. 30th Street NEW YORK, N. Y.

**CHEMICAL INSTITUTE OF NEW YORK**  
Home Extension Division 8  
16-18-R-E. 30th St. NEW YORK, N. Y.

Please send me at once, without any obligation on my part, your free book "Opportunities for Chemists," and full particulars about the Experimental Equipment given to every student. Also please tell me about your plan of payment.

RN. AUG. '28.

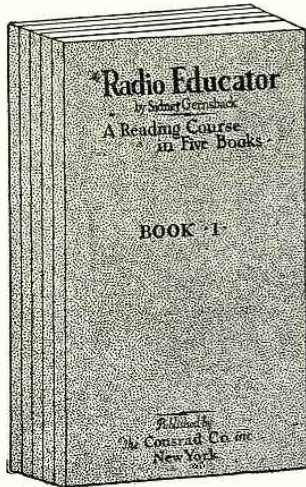

Price \$1.97

## A RADIO EDUCATION IN 5 VOLUMES "THE RADIO EDUCATOR"

Theory, Design, Construction,  
Operation and Maintenance

LEARN AT HOME

THESE five component parts of a complete Radio Instruction Course are outlined in five volumes that contain not merely the essentials as so many books do, but more, they contain all that any modern up-to-the-minute textbook on any subject would cover. They are in themselves a COMPLETE radio education teaching every possible portion of Radio science.

Size of each book 6 by 9 inches, handsomely bound and illustrated with charts, diagrams, descriptions of equipment, etc. Each volume 52 pages.

SEND NO MONEY for these books. Just forward your name and address. We send you the books at once. On receipt of same you pay the postman \$1.97 plus a few cents postage and then they are yours.

Distributed by

The Conrad Co.

Incorporated

230 Fifth Ave., New York, N. Y.

the switch (SW) is closed and should be off when the switch is opened.

Next, the antenna coil (L1) may be connected in the circuit. Terminal "A" of this coil connects with the "Aerial" binding post; terminal "B" connects with the "Ground" binding post; terminal "C" connects with the frame (rotor plates) of the condenser C1, and terminal "D" connects with the stator plates of C1. In addition, terminal "C" is connected to one terminal of the adjustable condenser (C3), and terminal "D" is connected to one terminal of the variable resistor R1, and the "G" terminal of vacuum tube socket V1.

In wiring the R.F. transformer in the circuit, terminal "A" is connected with one terminal of the fixed condenser (C4). This condenser has not been mounted on the baseboard, but is held in place with two wires; the other wire being that connecting the free terminal of the condenser with terminal "P" of the tube socket V1. Terminal "B" of the R.F. transformer connects with the "A—" terminal of V1; terminal "C" connects with the stator plates of C2 and the "B" terminal of the first A.F. transformer (T1); terminal "D" connects with the frame (rotor plates) of C2; and terminal "E" connects with one terminal of the crystal detector.

The next step in wiring should be to complete the connections to the binding posts. The "C—" binding post should be connected by wire to the "F" terminal of transformer T1. The "B+" binding post should be connected to terminal "B" of transformer T2, and the "F" terminal of this transformer should be connected to the binding post marked "C— Power." The binding post marked "B+ Power" should be connected to one of the tip jacks and the other tip jack should be connected to terminal "P" of the socket V2.

Six wires are now required to complete the receiver. First, connect the free terminal of the volume-control resistor R1 with the "G" terminal of transformer T1. Next, connect the "G" terminal of T2 with the "G" terminal of the tube socket V2. Connect terminal "P" of T1 with the free terminal of the crystal detector, and connect P of T2 with one terminal of the R.F. choke coil L3. Now connect the free terminal of the choke coil to terminal "P" of the tube socket V1, and run another wire from terminal "P" of the tube socket to the free terminal of the adjustable condenser.

#### TESTING AND ACCESSORIES

With the wiring of the receiver completed, the circuits should be carefully tested. To do this, insert tubes in the two sockets, connect one terminal of the "A" battery with the "A+" binding post and close the filament switch. Now connect a wire to the free terminal of the "A" battery and touch the free end of this wire to each of the free posts on the binding-post strip. The tubes should light when the wire is connected with the "A—" post; but they should not light when contact is made to the other posts. If the test does not prove that the circuits are correct, the wiring must be carefully tested until the error in wiring has been discovered.

After the set has been completed and tested it is ready for operation. It should be connected with an outside aerial approximately 100 feet in length, and the ground connection may be a wire firmly connected to a well-scraped spot on the nearest cold-water pipe. The tube in socket V1 should

be a 112A type, and the tube in the V2 position may be either a 112A or a 171A. A six-volt storage battery is used for providing filament current, 135 volts of "B" batteries are required for the plate supply, and 22½ volts of "C" batteries are needed for grid bias.

The 135-volt terminal of the batteries is connected to the post marked "B+ Power" and the 90-volt terminal to the "B—" binding post. The 22½-volt negative terminal of the "C" battery is connected to the binding post marked "C— Power," and the 3-volt negative terminal of this battery is connected to the binding post marked "C—."

The operation of the receiver requires no explanation. After the set has been turned on at the switch it is necessary only to adjust the dials (C1 and C2) until signals are heard at maximum strength, and then adjust the volume control until the desired signal strength is obtained.

## What's New in Radio

(Continued from page 125)

fixed by-pass condenser (C3) are used for the purpose. R1 and R2 are fixed filament resistors, but R1 produces also a voltage drop which is employed as a negative bias for the control grid.

In mechanical construction, the unit is very compact; it is housed in a metal cabinet 4½ x 6 x 7½ inches which serves also as a shield, and there are only two controls on the front panel, the tuning condenser (C1) and the battery switch (SW). At the rear of the unit will be found the exit hole for a four-wire battery cable (B) and the binding-post strip on which are mounted the two aerial posts and the output post.

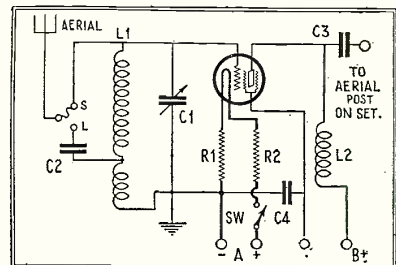

Circuit of the screen-grid booster unit. From 45 to 90 volts is used on the screen-grid, depending on the "B+" voltage of the amplifiers.

It is a very simple matter to connect the booster unit to any receiver. Usually the unit is placed at the left of the receiver so that it is convenient to tune the dial, connect the battery cable to the power supply used by the receiver, and run a wire from the unit to the aerial post of the set. All original connections to the receiver are left as they were except the aerial lead-in, which is connected to the proper post of the booster unit; then a wire is run from the output post of the latter to the aerial post of the receiver. After this has been accomplished, a 222-type (screen-grid) tube is placed in the socket of the booster unit and the installation is ready for operation. However, it must be remembered that, in order to operate the set, it is necessary to turn on the switch in the booster unit as well as that on the front panel of the receiver.

Manufacturer: Sterling Manufacturing Co., Cleveland, Ohio.

## Odd Uses for Tubes

(Continued from page 127)

any convenient frequency, says 1,000,000 cycles (300 meters). Then, if the oscillator detector is tuned near 1,000,000 cycles, a beat note will be heard in the telephone receivers. If we tune it exactly to 1,000,500 cycles, we shall hear a beat of 500 cycles. Or, if we tune the two oscillating circuits to any wavelength or frequency we please, if we make the difference between them equal to 1,000 cycles, we shall hear a 1,000-cycle note in the phones.

Now suppose we set our 1,000-cycle buzzer going. The 1,000-cycle current from this buzzer mixes with the beat note of the oscillators, and if the beat note of the oscillators is made exactly 1,000 cycles, we shall hear only one tone, since both tones are the same. But, if the beat note of the oscillators differs by even so little as a half a cycle per second from the 1,000-cycle buzzer, then we shall hear this beat in the phones. We shall still not be able to distinguish the two separate tones, for they differ too little to cause any perceptible change of musical pitch; but the beat note will be there, and is recognized as a rhythmic waxing and waning of the tone heard in the phones.

If it is desired, a crystal detector and a microammeter may be placed in series with the phones, and these beat notes can be seen, as the needle of the meter climbs up slowly and falls slowly, accompanying the waxing and waning of the note. These are secondary beats, and the phenomenon we have may be termed "beating of the beats." Of course we may make these secondary beats anything we please, and may vary them from perhaps two beats per second up to the audible limit, which is somewhere about 10,000 per second.

### ULTRA-DELICATE MEASUREMENTS

Now, if any of the constants of either oscillating circuit are changed, even in the minutest degree, the secondary beat note will change. So, if we want to measure a very small capacity, we may connect it across the terminals *ab*, of Fig. 5. Then we adjust the variable condenser *C* by a micrometer dial or screw so that the secondary beat is as near zero as possible. Next, disconnect the unknown condenser from the terminals *ab*. Secondary beat notes will be heard in the phones, or seen on the microammeter. In order to make the secondary beat again zero, condenser *C* must be decreased slightly; and the amount we have to decrease it is equal to the capacity we are trying to measure. Great care must be taken in making such measurements, for the apparatus is extremely sensitive. The capacity of a two-inch piece of bus-bar is easily and accurately measured, if condenser *C* is accurately calibrated.

To illustrate how the apparatus may be used to measure extremely small weights, the terminal *a* can be connected to the pan of a sensitive chemical balance and terminal *b* to a plate beneath the pan. The slight motion of the pan when a small weight is placed upon it is detected as a change of capacity (in the condenser formed by the pan and the plate beneath), which is measured exactly as described in the preceding paragraph.

By special arrangements of apparatus, it has been possible to measure a weight as

# Solve Your Radio Problems with Electrad Radio Controls

These resistances are backed by the highest reputation of quality. We must uphold that reputation. Therefore, only the most scientific designs and finest materials are used in their construction. To assure the highest order of performance and satisfaction, *insist on Electrad Controls.*

*Electrad specializes in a full line of Controls for all Radio Purposes*

## PHASATROL

Reg. U. S. Pat. Off.

### A TRUE BALANCING DEVICE FOR RADIO FREQUENCY AMPLIFIERS

You can solve the problem of R. F. oscillation noises by inserting a Phasatrol for each stage of R. F. amplification. After installation of Phasatrol, it is possible to adjust its variable resistance to a permanent value for an amplifying tube so that no further chance of oscillations breaking out is experienced. Very easy to install in the circuit. Price \$2.75 each.

## TONATROL

Trade-mark

### A COMPLETE LINE OF VOLUME CONTROLS

Smooth, gradual control of intensity under all conditions will be your reward if you incorporate the Tonatrol Volume Control in your receiver. Tonatrols are variable resistors of the famous Royalty type, especially designed with the requirements of different circuits in mind. Furnished in standard types or with battery switch or power switch attached. From \$1.50 to \$3.00.

## ROYALTY

### VARIABLE HIGH RESISTANCES

A standard resistance widely recommended for its accuracy and dependability wherever variable high resistances are required in high frequency circuits. There is a type for every radio purpose—11 in all, designated Type A to Type L. Potentiometer types, \$2.00. All others, \$1.50.

Please send me descriptive circulars on the following products and put me on your mailing list for similar literature: General Circular; Tonatrol Volume Controls; Phasatrols; Royalty Variable Resistors; Truvolt Divider Manual (enclose 10c. for mailing); Electrad Control Manual (enclose 10c. for mailing); What B. Eliminator Shall I Build? (enclose 10c. for mailing). I am particularly interested in.....

**Mail Coupon for full information**

Name.....  
Address.....  
City..... State.....

# ELECTRAD Inc.



**IDEAS!** A handy manual of 36 illustrations—over 20,000 words—practical—concise—understandable—prepared by Austin C. Loscarboura and our engineering staff. That's "The Gateway to Better Radio"—yours for 25c., from your dealer or direct from us.

**American Mechanical Labs., Inc.**  
Specialists in Variable Resistors.  
285-7 N. Sixth St., Brooklyn, N. Y.

## AIRPLANE CLOTH SPEAKERS

Send for Free Catalog

It contains many bargains in all types of Cone Speakers. Units, complete parts to build all types of cone speakers. Also the latest parts of the New AIRPLANE Cone Speaker. Accessories.

ACCUSTI-CONE, 1 No. 7th St., Phila., Pa.

## Tyrman '70'

Shielded Grid Amplimax

USING SHIELDPLATE TUBES TYPE SP122

Absolutely New and Different

The fastest selling kit on the market. Has been acclaimed "America's Greatest Receiving Set" by Radio Engineers, Designers, Editors, and Jobbers. Set Builders have been astounded by the revolutionary performance of this receiver. Write for details or ask your dealer today.

**TYRMAN ELECTRIC CORPORATION**  
314 W. Superior Street Chicago, Ill.

## SEND FOR FREE CATALOG

From Chicago's Oldest Radio Jobbers. The most valuable Radio Catalog. Write for your copy today—IT'S FREE!

**TELEPHONE MAINTENANCE CO.**  
123-5 S. Wells St., Dept. 87 Chicago, Ill.

Insure your copy reaching you each month. Subscribe to Radio News—\$2.50 a year. Experimenter Publishing Co., 230 Fifth Avenue, New York City.

## BUILD A DAVEN TELEVISION RECEIVER

COMPLETE ESSENTIAL KIT—\$45.00

The first complete Kit enabling anyone to build his own Television Receiver—and sponsored by Daven! The Kit consists of a Daven 21-aperture scanning disc for receiving WGY, Daven Motor, Bushing, Daven Television Tube, Three complete stages of Daven Television Amplification and Instructions for Building.

## DAVEN 2-STAGE POWER ESSENTIAL KIT—\$10.00

For use with 210 tubes—2 stages of Daven Power Television Amplification complete with Daven Super Davohms and Instructions for Building.

## DAVEN TELEVISION APPARATUS

	Each
Daven Television Scanning Disc, 24 apertures for WGY	\$5.00
Daven Television Scanning Disc, 36 apertures for WRNY	6.00
Daven Television Scanning Disc, 48 apertures	7.00
Daven Special Television Amplifier (3-T)	12.50
Daven Television Tubes, 20 to 30 milliamperes, striking voltage 150, Plate 1½x1½ in.	12.50
Daven Television Motor	15.00
Daven Bushing to fit ¼, ⅜ and ½-in. motor shafts	1.00
Daven Television Photo Electric Cell	25.00
Daven Television Resisto-Couplers (stages 1, 2 and 3) for stages 4 and 5	1.25
Daven Mu-20 Tubes for Amplifier Stages	4.65
Daven AC-71 Tubes for output tube in series with Television Lamp	2.25
Daven AC-10 Tubes for output tube in series with Television Lamp	3.50
	9.00

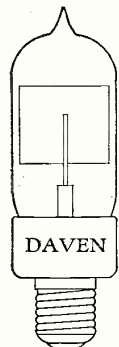

Write for Television Booklet  
**THE DAVEN CORPORATION**  
 Amplification Specialists Newark, N. J.

small as one thirty-thousandth of an ounce, and a change of distance between two plates of only one three-millionth of an inch has been detected by this method!

The zero-shunt ultra-micrometer is used in a similar manner. It is shown in Fig. 6 and is seen to consist of a simple oscillator. In the plate circuit of the oscillator is placed a resistor, and across this are connected in series a battery, a microammeter or galvanometer, and another variable resistor. The purpose of this latter shunt circuit is to enable us to use the most sensitive electrical measuring instrument known to science, the galvanometer; hence the name of the system.

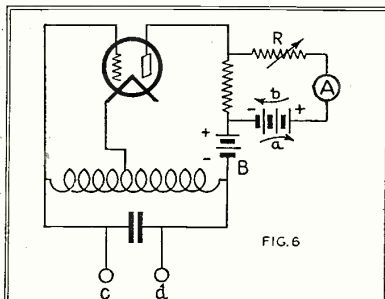

The "zero-shunt" ultra-micrometer circuit is sensitive to the smallest capacity changes.

The polarity of the batteries is arranged so that, whereas the "B" battery tends to send current around the shunt circuit through the galvanometer in the direction of the arrow *a*, the other battery opposes this, trying to send current through the galvanometer in the direction of the arrow *b*. By properly adjusting the resistor *R*, the two may be made equal; so that we have a net zero current flowing through the galvanometer circuit. Hence the name "zero shunt."

The plate current of an oscillator is very sensitive to changes of inductance or capacity. Consequently, suppose we start our oscillator going and add a very small capacity to the terminals *cd*. A change in the value of the plate current will take place. If, before we add the capacity to the terminals *cd*, we adjust the resistor *R* so that the galvanometer reads zero, then on adding the unknown capacity to *cd*, the change of plate current will produce a deflection of the galvanometer. This system is almost as sensitive as that previously described.

Before closing this article, it will be well to remind the reader that we have by no means exhausted the list of applications of the vacuum tube. We have not touched upon the multi-grid tubes, which have a number of applications. We have not mentioned the application of vacuum tubes to systems employing photoelectric cells. Indeed, it was the vacuum tube that made it possible to use the photoelectric cell effectively, on account of the amplifying properties of the former. We have not touched upon the various relays and remote control systems made possible through the use of the vacuum tube as a detector and amplifier of very weak impulses. Radiodynamics, or control at a distance by means of radiations of various kinds, has profited greatly by the vacuum tube. And last, but by no means the least, we have the oscillators, speech amplifiers, modulators, regulators, in broadcast stations.

## S. GERNSBACK'S RADIO ENCYCLOPEDIA



S. GERNSBACK'S RADIO ENCYCLOPEDIA is the first radio encyclopedia ever compiled. The many-sided labor of research involved in collecting the vast amount of information required to make this work a complete, dependable, and accurate guide, can best be realized from the fact that it took over two and one-half years to gather the material that it contains.

Every known circuit, each and every hook-up, every modern development in radio and electricity, every person of renown in the radio world, every word used in radio practice—this is what you will find in S. GERNSBACK'S RADIO ENCYCLOPEDIA.

But you will find it much more than just a dictionary of these terms. This pioneer radio encyclopedia is a manual of applied information, a working guide and instructor and an endlessly useful reference aid. There are 1,930 detailed definitions, 549 photographs, diagrams of circuits and drawings. A complete cross-index is just one of the many features of this remarkable book.

### S. GERNSBACK'S RADIO ENCYCLOPEDIA can be had in either of two beautiful bindings.

The luxurious limp suede edition (\$5.00 a copy) was made to meet the demand for a more handsomely bound volume, after the usefulness of the book had been demonstrated by its extraordinary popular success in its plain first dress. This edition, designed for those connoisseurs who admit only choicely covered volumes to their libraries, is a masterpiece of *de luxe* binding.

The keratol-bound edition of this master Radio Encyclopedia can still be had for the original price of \$2.00. This is a neat, sturdy, workman-like book, offering precisely the same text, on equally attractive type pages.

Both editions are of the large 9" x 12" size, printed in clear, legible, large type. Both are adorned with gold-embossed cover titles.

More than 25,000 copies of the keratol-cover edition have already been sold, and are now being used, day in and day out, by that number of actual workers and students of radio, in colleges, schools, and public libraries, and special radio and other scientific institutions in every state in the country.

Mail this coupon now. No radio enthusiast can afford to be without this authentic guide, convenient and attractive in form, unfailingly serviceable in content—S. GERNSBACK'S RADIO ENCYCLOPEDIA.

S. GERNSBACK'S RADIO ENCYCLOPEDIA  
 Limp Suede Bound Edition . . . . . \$5.00  
 Keratol Leather Stiff Binding . . . . . 2.00

### S. GERNSBACK

230 FIFTH AVE., NEW YORK, N. Y.

S. GERNSBACK,  
 230 Fifth Ave., New York, N. Y.  
 Kindly send me one copy of THE RADIO ENCYCLOPEDIA. I will pay postman.  
 Limp suede leather binding—\$5.00 plus postage.  
 Keratol leather binding—\$2.00 plus postage.  
 (check which binding you want)

Name.....  
 Address.....  
 City..... State.....

# CARTER

## New Outlet Plate

FOR AERIAL-GROUND AND POWER RECEPTACLE FOR A. C. SETS

Finished in  
 Satin Brass... \$1.00  
 Brown Bakelite..... 1.25  
 Etched  
 Bronze..... 2.25

Folder on complete wiring of house furnished on request

MEMBER RMA

**Carter Radio Co.**  
 CHICAGO

# M&H

## Radio's largest kit supply house

ESTABLISHED 30 YEARS

We Have Complete Kits For All Circuits  
 Now appearing or which have appeared in "Radio News" and other publications.  
 Send for Circuit Booklet & Catalog

M. & H. Sporting Goods Co.  
 512 Market St. Phila., Pa.

6-TUBE RADIO COMPLETE  
 \$34.75 to \$66.66  
 Licensed R.C.A. Circuits. Shielded. One Dial  
 Write for catalog. Big discounts to agents  
 Consumers Radio Co., Dep. 148-4721 Lincoln Av. Chicago

## Radio Movies

(Continued from page 118)

outer drum upon the mirror. The light thus produced on the mirror follows the shading of the images on the original film, so that a picture is built up in the mirror. This may be observed through the magnifying mirror.

A complete picture of 48 lines (corresponding to the rate of transmission) is built up on the mirror with every four revolutions of the drum. At the beginning of the second revolution, the contact brushes turn to the next segment of the switching ring (because of the gearing) and the second target of the neon tube is illuminated. The third and fourth quarters of the picture are similarly built up from targets 3 and 4, and the cycle then begins again with No. 1 and the first spiral of holes. During one second the drum turns 60 times; since four revolutions create one picture, 60 revolutions create 15 pictures. This gives us the speed of 15 pictures per second mentioned in the early part of this article.

Of course, it is necessary to maintain perfect synchronism between the transmitting and receiving motors, as in all systems of

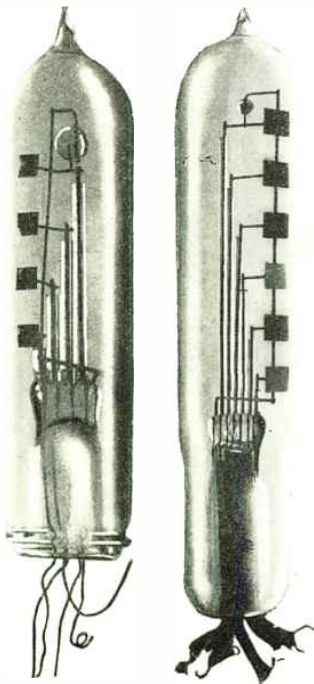

Left: A four-target neon tube, used in the radio-movies receiver. Right: an experimental six-plate lamp.

television and radio photography. In the Washington demonstrations the transmitter and the receivers were on the same power line, so little difficulty was experienced in keeping the pictures steady.

The pictures, as they appear through the magnifying lens at a distance of about ten feet, are clean-cut black silhouettes against the characteristic reddish glow of the neon tube. They possess no fine shading; as such refinement is not possible without the use of a very wide band of frequencies at the transmitting end.

# HAMMARLUND Presents a New Knob-Control DRUM DIAL

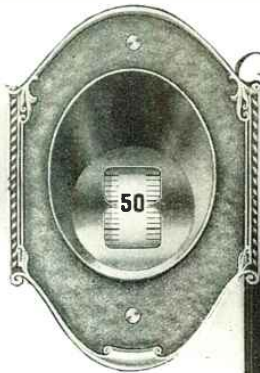

A richly embossed oxidized bronze escutcheon of exclusive design and graceful proportions. Figures and graduations are illuminated from the back.

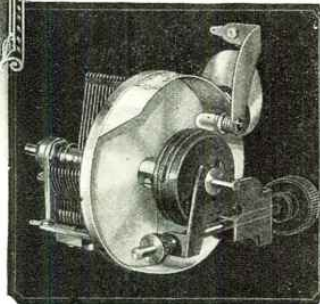

Back View

Note position of the Control Knob. By using a Condenser Shaft of suitable length, the Control Knob may be placed at any desired distance from the dial, thus giving a pleasing balance to the front of the panel.

**H**AMMARLUND now offers a new illuminated drum dial of unusual beauty, rugged design, and distinctive mechanical features.

It is controlled by a knob, cleverly planned to be placed in any position on the panel, desirable for attractive balance.

The driving mechanism utilizes an exceptionally strong silk and linen cord, gripping a drum, snubber fashion. It cannot slip—absolutely no back-lash or lost motion.

Thoroughly tested for wear under actual working conditions, this cord withstood 36,600 full-range movements of a large multiple condenser without stretching, fraying or breaking. It will never receive similar treatment in average use.

The original Hammarlund two-finger-control Drum Dial, introduced last season, will be supplied for those preferring that type.

If your Dealer can't supply you, write direct to us. Ask for Hammarlund literature.

HAMMARLUND  
MANUFACTURING  
COMPANY

424-438 W. 33rd Street  
New York

For Better Radio  
**Hammarlund**  
PRECISION  
PRODUCTS

## ANOTHER SPECIAL OFFER!



### UNI-RECTRON POWER AMPLIFIERS

Model AP-935



As the Uni-Rectron stands it is a super power amplifier, which can be used in connection with any radio set and loud speaker. Binding posts are provided for input to the Uni-Rectron and output to the speaker. Requires no batteries for its operation. It obtains its power from the 110 volt, 60 cycle alternating current lighting circuit of your house.



List Price \$88.50  
(Without tubes)

**Special \$19.75 ea.**

Every one new and packed in original factory carton

AMERICAN SALES CO., 19-21 WARREN ST., NEW YORK CITY

The UX-210 super power amplifying tube and the UX-216B or 281 rectifying tube are used with this amplifier, which cannot overload. From the faintest whisper to the loudest crash of sound—R. C. A. Uni-Rectron amplifies each note at its true value. High and low notes are all treated alike. The volume and quantity delivered will be a revelation.

# The RADIO NEWS AMATEURS HANDIBOOK

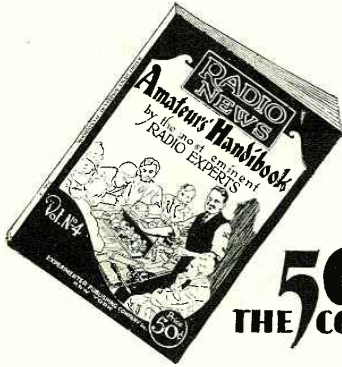

**50¢  
THE COPY**

for **TECHNICAL  
RADIO FANS**

**EVERY WORTHWHILE  
DEVELOPMENT**

**NEW CIRCUITS  
AMPLIFIERS  
SHORT-WAVE SETS  
TRANSMITTERS  
THEORIES &  
PRACTICES**

Every worthwhile development of radio can be found reflected somewhere within the pages of this great collection of circuits. The latest and approved methods of amplification, new and tried receiving circuits, transmitters—everything of interest to the experimenting fan is accurately and unbiasedly treated in this amazing Handibook. The RADIO NEWS AMATEURS' HANDIBOOK might be truly said to contain authentic data on every important event that has taken place since the beginning of radio as an industry.

For the fan who loves to tinker with radio, the "Handibook" should prove a great help. Get your copy now. Fill in the coupon. There is a complete radio education in the pages of the RADIO NEWS AMATEURS' HANDIBOOK.

*Over 116 pages—fully illustrated—  
Replete with circuits on every  
worthwhile development. Me  
this coupon now*

**EXPERIMENTER PUBLISHING CO., Inc.**  
230 Fifth Ave. New York, N. Y.

**EXPERIMENTER PUBLISHING CO., INC.**  
230 Fifth Ave., New York, N. Y.

Gentlemen:  
Enclosed find 50c., for which please send me a copy  
of the RADIO NEWS AMATEURS' HANDIBOOK.

Name.....  
Address.....  
City..... State.....

## A Booster Unit for the Browning-Drake

(Continued from page 141)

winding and approximately 1,500 turns are needed. The drawing (Fig. 4) gives full details of the coils used in this unit.

Fans who do not wish to wind their coils may use standard apparatus. As a choke coil, a standard 85-millihenry choke is entirely satisfactory, and the secondary of an R.F. transformer may be used for the aerial coil after the primary winding has been removed. However, it is important to make sure that the transformer has been designed for use with a .0005-mf. tuning condenser.

### ASSEMBLY

The construction of the unit is so simple that little need be said regarding the method to be followed. The panels are drilled

and tested, a shield should be made before the unit is permanently installed. This shield may be constructed from sheet copper 1/64- to 1/32-inch thick. The shield is 6 7/8 inches high, 8 3/4 inches deep and 4 5/16 inches wide. The front end of the shield is left open for the front panel, and a hole 2 1/4 inches high is cut in the rear of the shield at the base for the binding-post panel. In making the shield, solder is used to hold the edges together.

### USE A SCREEN-GRID TUBE

In the letters received after the publication of a constructional article in this magazine, many requests are always found for data telling how to adapt the receiver to the new screen-grid tubes. In anticipation

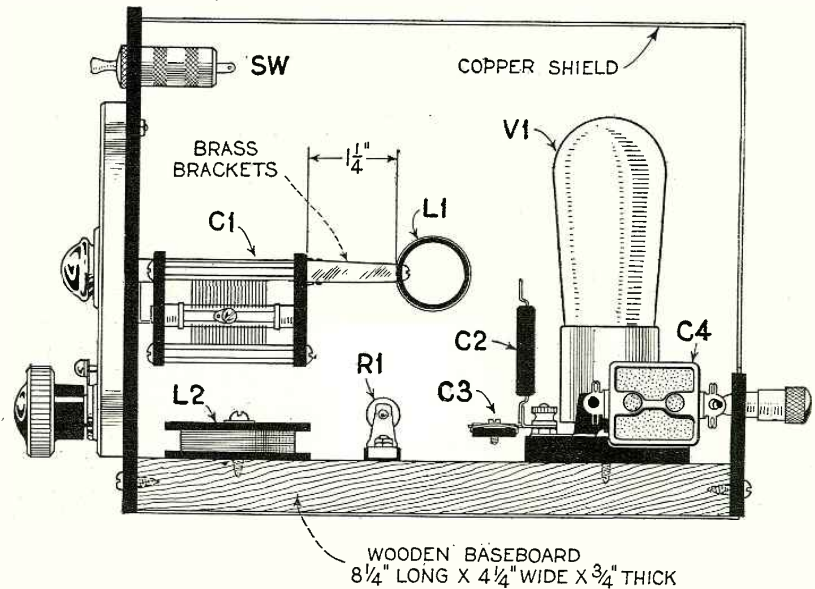

Fig. 5. This cross-sectional view of the Booster Unit shows the placement of the assembled parts, and the position of the shielding when it is placed over the unit.

according to the layout given in the accompanying diagrams. Five binding posts are mounted on the small panel and this may then be fastened to the rear of the baseboard with wood screws. The variable condenser (C1) is mounted in the center of the large panel and the battery switch is mounted above the condenser. After the condenser has been mounted the aerial coil (L1) should be fastened in place with brackets as shown in the drawing.

Before fastening the front panel to the baseboard three parts should be mounted on the latter; they are the R.F. choke coil (L2), the filament-ballast unit (R1), and the tube socket. The remaining parts include only the fixed condensers which are held in place by the wiring.

There is nothing of particular importance to mention with regard to the wiring or testing of the unit, as everything is so simple that it is difficult to make a mistake. Flexible insulated wire should be used for the purpose and all connections should be soldered.

After the booster has been constructed

of this demand the circuit diagram of this booster unit wired for operation with a 222-type tube has been prepared and will be found in Fig. 6. From this diagram it may be seen that very few changes have to be made. First, the filament-ballast unit is removed and the resistors R2 and R3 are substituted. These resistors should have a total resistance of 17 ohms and should be divided in such a way as to provide the grid of the tube with the proper bias. If the voltages suggested by the tube manufacturer are used, the total resistance may be placed in R2, and then R3 would be eliminated. However, if lower voltages are used, R2 should be made smaller and R3 proportionally larger. An arrangement which usually gives satisfaction gives R2 a resistance of 11 ohms when R3 is a 6-ohm resistor.

The second change is the elimination of the neutralizing condenser (C3), and the third change is the substitution of a shielded socket for the standard UX-type socket. Also, an extra binding post is required for the screen-grid voltage. (See Fig. 6).



# Rain, Rays and Radio

(Continued from page 113)

a hastily-scribbled message to his chief.

"Return at once to Hollywood to pick up fluoroscope. (Signed) Wynn."

"Right!" nodded Dare. He handed the message to the pilot, who nodded, swung his controls, and headed the ship swiftly about in the opposite direction.

\* \* \*

"What do you believe," demanded Harold Dare, as an hour later they were approaching the range of peaks behind which lay Health Valley, "to be the cause of the strange phenomenon which Dr. von Stüeck reports?"

"It could have been but one thing," replied the great Scott. "A fluoroscope, as you know, merely converts light of a frequency so high as to be invisible, into light which can be detected by the human eye. Evidently there is in the atmosphere a display of some radiation higher in frequency than the extreme violet. It might be anything between ultra-violet light and gamma rays—or even the cosmic ray."

Scott raised his fluoroscope to his eyes and stared steadily toward the dark masses of cloud on the distant horizon, while Dare peered ahead through a pair of binoculars. Only under the black pile of clouds did streaks of yellow light show that rain was falling.

Swiftly they drew near, and as beyond the nearest rim of mountains appeared rain-drenched Health Valley, the earth beneath them was hidden in a low-hanging floor of cloud. A bright flash of light illumined the fluoroscope; and to the radio operator at his set came a strange shock; for in a hissing of static, the signals of WROT at Hollywood vanished, and instead through the turmoil, sharply shrilled the piping note of WROU at Health Valley!

Now Scott saw that the bright streamers were beams, as of a circle of searchlights concentrated on a spot in the center of the bank of clouds. He drew out his watch, removed its crystal, and held it up in front of the fluoroscope. A round shadow showed that the radiation did not penetrate the glass.

"Ultra-violet!" exclaimed Scott.

At last the solution of the mystery lay clear in his mind.

"Land at Health Valley!" he directed. "We shall catch the conspirators red-handed!"

The rest of the story belongs to history: how the Dare forces, under the courageous leadership of Harold Dare himself, went out into the surrounding hills, surrounded and captured Dandy Diavolo and his henchmen; and how they found cleverly concealed in the underbrush a dozen huge mercury-vapor arcs for the production of beams of ultra-violet light.

"And yet," demanded Harold Dare, after his prisoners had been safely manacled and hustled back to Hollywood by a convoy of armed guards, "there are a few points which are not clear in my mind. Just how did Diavolo produce rain by the use of ultra-violet radiation?"

"Well," replied Scott, "the purpose of the ultra-violet searchlights was to break the atoms of the atmosphere into ions—

# Carefree Reception

With a **TOWNSEND "B" Socket Power**

A.C.-D.C. Any Cycle

Delivers up to 100 volts on any set. Full cone. Clarity, Volume, Distance.

## Logs 380 Stations From CUBA to CANADA!

Never in the history of Radio has there been anything that gets such sensational results at this astounding low price. Just read this letter received April 26th, 1928: "Your Townsend does its work, and more besides. I have it working about six or seven hours every day. I have tuned in 380 Stations all over the country, and Canadian, Cuban, Mexican, and Haiti Stations—all on a 5-tube Atwater Kent. And besides, only a 60-foot Antenna. Yes sir, it is a dandy! Nobody can beat it."

(Signed) WM. SCHULTZ,

72 Seventh Ave., N., Tonawanda, N. Y.

Just plug a Townsend "B" Power into light socket and get your share of these radio thrills.

### SEND ONLY \$1.00

Simply fill out coupon and slip it into an envelope with only \$1.00 and mail at once. Your Townsend "B" Socket Power Unit will be sent promptly. Deposit only \$5.85 plus postage with the postman. Try out 10 days—then if not more than pleased return it, and purchase price will be refunded.

## TOWNSEND LABORATORIES

713 Townsend Street Dept. 25

CHICAGO, ILL.

Money Back Guarantee

Approved and passed by the rigid laboratory tests of Popular Radio and Radio News

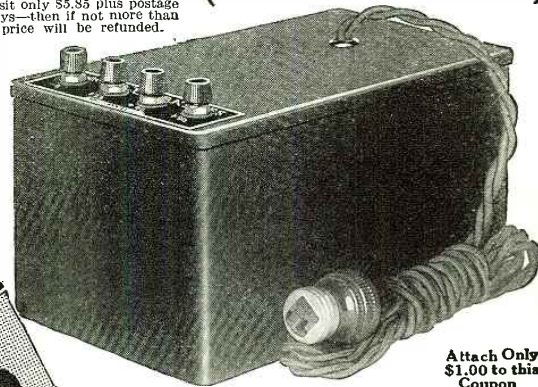

Attach Only \$1.00 to this Coupon

Complete \$6.85 \$1.00 Down Balance C.O.D.

10 Days' FREE TRIAL

Send for Literature

TOWNSEND LABORATORIES - 8-28  
713 Townsend St., Dept. 25 Chicago, Ill.  
Gentlemen: Attached find \$1.00. Kindly send at once Townsend "B" Socket Power Unit, C.O.D. for \$5.85, plus postage, on guaranteed 10-day free trial.

Name .....

Address .....

City..... State.....

# Balkite Radio

**BIG New SUMMER RADIO CATALOGUE**

DEALERS—SET BUILDERS—AGENTS

Write for this Catalog. New Summer and Fall Book. Save money on newest booklets, sets, kits, parts, accessories at lowest prices.

The "Big, Friendly Radio House"

WESTERN RADIO MANUFACTURING CO.  
126 West Lake Street, Dept. 18 Chicago, Illinois

## New DYNAMIC Speaker

Operates on electro-inductive principle

Write for particulars.

ALSO

DYNATONE ELECTROMAGNETIC POWER SPEAKER UNITS

FANSPEAKER RADIO COMPANY

74 Dey Street - - - New York, N. Y.

# MUTER

Dependable Radio Products

The Complete Quality Popular Priced Line—  
Send for Comprehensive Catalog

LESLIE F. MUTER CO.  
76th and Greenwood Dept. 827-L Chicago

## CONSIDER FIRST— The Volume Control

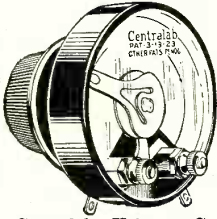

Care must be taken to choose Volume Controls that give longest trouble-free service—a type that will not introduce noise to interfere with quality of reception after a short period of service.

Centralab Volume Controls have a patented rocking disc contact that eliminates all wear on the resistance material. This feature adds to the smoothness of operation, because a spring pressure arm rides smoothly on the disc and NOT on the resistance. Bushing and shaft are thoroughly insulated from the current-carrying parts. This simplifies mounting on metal panel or sub-base and eliminates any hand capacity when the volume control is in a critical circuit. Full variation of resistance is obtained in a single turn of the knob.

Centralab has carefully studied every volume control circuit and has built-up tapers of resistance that for each application assure a control that smoothly and gradually varies volume from whisper to maximum.

The specific circuit in which each of these units is used, is outlined in a folder. Write for it.

CENTRAL RADIO LABORATORIES  
19 KEEFE AVE. MILWAUKEE, WIS.

**Centralab**

## XL Products



Used in Every High Grade Circuit or Receiver Today!

X-L NEW BAKELITE INSULATED BINDING POSTS

The perfect binding post at last! Convenient, simple, permanent connections. You don't have to remember to tighten them. Push down the X-L, insert wire, remove pressure. Connection is tight and will STAY tight. No vibrations can loosen. Release instantly. Engraved in all standard markings. Price each, 15 cents.

FREE Big new up-to-date book of wiring diagrams of all leading circuits. Write today for copy.

**XL Radio Laboratories**

Dept. A, 1224 Belmont Ave., Chicago, Ill.

## FREE RADIO CATALOGUE

To Dealers—New illustrated 1928 Wholesale Radio Catalogues lowest prices on accessories, kits, packs, parts and sets. Features master-built single control radio sets for both battery and all-electric operation. Full showing of "A" and "B" eliminators and thousands of other great values. Write on business letter-head for this free book today.  
**HAMILTON-CARR RADIO CORPORATION**  
711 West Lake St., Dept. 396, Chicago, Ill.

## Amplipack Makes Your Set a Modern A.C. Power Receiver

AT ALL LEADING DEALERS CAN BE ASSEMBLED IN ONE EVENING

**FREE BOOKLET** The latest word on Power Amplification and A.C. Conversion. Send for it.  
**TRANSFORMER CORPORATION OF AMERICA**  
1428-1432 Orleans Street Chicago, Ill.

that is, into free electrons and protons, or nuclei. Rain is often formed by moisture collecting on particles of dust or charged particles existing as a result of ionization. Diavolo chose a time when a good deal of moisture was present in the atmosphere. This moisture then settled on the ions formed by the ultra-violet rays, and gradually grew into drops large enough to fall to earth.

"To illustrate the electrical action, think of two spherical drops of moisture, each containing a positive charge. When the two combined, they would form a larger sphere. But the charge on a sphere is proportional to the radius, and the radius of the larger sphere is certainly not twice that of the two small ones. Therefore the potential of the new sphere would rise, and in this manner clouds formed by this process would accumulate a high potential. Other clouds would be negative with respect to these which were more highly charged, and would be attracted, so that the clouds would grow larger and heavier. By the same process, the earth, also negative with respect to the highly-charged cloud, would attract the moisture drops, and a heavy precipitation would result."

"But how would this affect radio communication?" inquired Dare.

"Because any substance containing free electrons, any substance easily ionized, is a good conductor of electricity. Now these beams of ultra-violet light were arranged in a circle about Health Valley. Any radio wave coming from the outside would meet one of these beams and be conducted directly to earth. The same thing would be true of signals originating in the valley itself. The circle of beams formed a shield, just as a sheet of metal placed about a radio coil shields the coil from outside influences."

"So," mused Harold Dare, "if an accident had not intervened, if Dr. von Stück had not looked up through his fluoroscope just at the right time, our whole plan for the development of a great health resort and model city would have been ruined, and we would have lost the confidence of the entire world. The long arm of coincidence has saved us."

"Yes," agreed Scott; "as Dandy Diavolo should have learned long since that, in real life just as truly as in reel life, the long arm of coincidence invariably reaches out to protect the virtuous from the machinations of wrong. If Dandy Diavolo would not extend his career of villainy to life beyond the camera, he would not meet with disaster and retribution."

However (he added to himself), then there would have been no story.

### Power Tubes Get Hot

RADIO tubes of the 199 and 201A varieties do not develop much heat, even after they have been in operation for several hours; but power-amplifier bulbs of the 171 and 210 types get quite hot.

Therefore, before touching these latter tubes after they have been in use for more than five minutes, turn them off and give them a chance to cool, otherwise you may acquire a few small but painful blisters. The heat generated by these tubes is a normal part of their operation; it is nothing to worry about.

The same remarks apply to "B" rectifier tubes, only more so, as these tubes handle considerably more power than amplifiers.

# YOUR BODY

KNOW THYSELF  
*A Quarterly Magazine*

NOT A "HEALTH" MAGAZINE

POPULAR PRACTICAL KNOWLEDGE ABOUT THE MECHANISM OF THE ORGANS OF THE HUMAN BODY

SEXOLOGY PHYSIOLOGY MEDICINE ANATOMY ON ALL NEWSSTANDS 50¢ A COPY

DEVOTED TO THE WELFARE OF THE HUMAN BODY

EXPERIMENTER PUBLISHING CO.  
230 FIFTH AVE.  
NEW YORK CITY

## Weather Affects Radio

(Continued from page 121)

in the transmitted wave are similar to power variations; and the result is that the received signal will vary in intensity. This form of fading is slight compared to that produced through other natural phenomena.

Much has been said about the effect of weather on the intensity of radio signals. It seems to be true that this occurs; but the correlation is generally associated with temperature more than with air pressure, except that pressure and temperature always are directly related. In other words, reception is best, and reaches over greater distances, during clear cold weather, and is not so satisfactory, relatively, in warm and stormy weather. Regardless of the time of year, temperature is higher during cloudy and stormy periods and lower when the weather is clear and the air pressure higher. Clearing weather is associated with a fall in temperature, and is decidedly more favorable to the best radio reception and freedom from static.

### THE WEATHER MAP AND RADIO

Some investigators have found that, when two different weather areas, or centers of differing air pressure, are indicated on a weather map, reception will be best along a line drawn connecting the centers of the two pressure areas. Such a line will then cross the "isobars," which are lines connecting points of equal air pressure. There is no sound reason for this theory. Certainly there is nothing known to meteorology to justify it, yet on the face it is quite obvious. However, exceptions to the rule are such that the theory cannot be accepted as conclusive.

In this case, we might best consider temperature lines or "isotherms," which are lines connecting points of equal temperature, and their relation to air pressure. Isotherms and isobars are seldom parallel; the former being mostly at right angles to the latter. Therefore, if we are to say that reception is best along a direction which is across the isobars, it is then best in a direction mostly parallel to the isotherms, or at least through an area of equal temperature. While the continuity of isotherms is often broken, due to local temperature conditions, elevation, etc., the writer holds that reception is best through an area of equal temperature, which may or may not be across the isobars.

Summing up the meteorological effects which stand out as the most obvious, we have:

### SOURCES OF RADIO TROUBLE

Static produced by drifting, and irregular densities, of charged atmospheric gases coming in contact with the antenna.

Static produced through wave effects created by electrical discharges between the differing potentials of charged masses of gas, clouds, and the earth's surface below (lightning).

Static produced through surges of earth currents due to attraction of overhead atmospheric and cloud charges.

Static produced through induction in the antenna and receiver because of passing overhead cloud and atmospheric charges.

Fading produced by great drifting ionized masses in the atmosphere, which alter

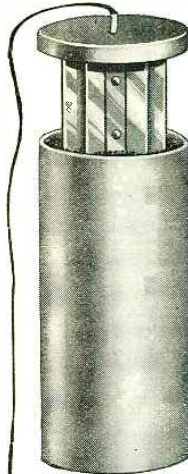

INSTALLED  
IN A FEW  
MINUTES



# Ground Out Stat'c with SUB-AERIAL

Let Ground Waves Bring You Amazing Distance, Crystal Clear Tone Quality, and Greater Volume and Selectivity without Distortion.

SUB-AERIAL has brought a new epoch in Radio. No need longer to bother with troublesome overhead Aerials. Why risk breaking your neck to put up roof aerials only to have the first storm blow them down? Forget your Aerial troubles. Why not use the whole earth as a static and noise filter with Sub-Aerial?

### COSTS NO MORE THAN AN OVERHEAD OR LOOP AERIAL

and less than many. Hook your set on to the newly discovered Ground Waves that bring practically static-free reception. Don't stand for the squawks and tin-pan reception you get from Air Waves when you can step right out and leave that stuff.

If you don't believe us, try it yourself. If you do not find we're right—absolutely right—you don't pay us a cent for the test.

## TRY IT FREE!

We know so well the surprising results you'll get that we'll let you put in a Sub-Aerial entirely at our Risk.

Don't take down your overhead Aerial. Pick a summer night when static and noise interference on your old Aerial are "Just Terrible." If Sub-Aerial doesn't Sell Itself to You Right Then on Performance—you needn't pay us a cent. Send for "all the Dope on Sub-Aerial." You'll be surprised. Do it NOW.

### Underground Aerial Systems

St. Clair Bldg., Dept. 9-L.  
Cor. St. Clair and Erie Sts.,  
Chicago, Ill.  
Mail Coupon NOW

UNDERGROUND AERIAL SYSTEMS, Dept. 9-L,  
St. Clair Bldg., cor. St. Clair and Erie Sts., Chicago, Ill.  
Send me complete information on Sub-Aerial, Proof and Free Trial Offer. No obligation.  
Name \_\_\_\_\_ Address \_\_\_\_\_ City \_\_\_\_\_ State \_\_\_\_\_

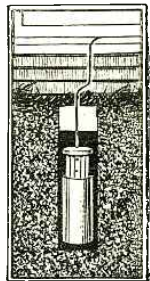

## Golden Bear AIR COLUMN SPEAKER

### THE SOUL OF RADIO

GOLDEN BEAR SPEAKERS embody the most advanced principle of air column construction. They reproduce both music and voice with full and natural tone values. They afford greater amplification without distortion and have the full range of reproduction. Made especially for manufacturers, being very compact, with long tone travel. Write for catalogue. Manufactured by M. J. CARLS, 1929 South Los Angeles St., Los Angeles, Calif.



### VICTOREEN Super Coils

Send for Folder and our Blue Print of the new A. C. circuit.

Geo. W. Walker Co.

2825 Chester Avenue

Dept. B Cleveland, Ohio

## FREE RADIO GUIDE

BIG NEW 1928 CATALOG—4000 items Shows the latest A-C circuits, the newest ideas in radio at startling low prices. Get the sets and parts you want here. Save money. The best in parts, kits, complete factory-built sets and sundries. Orders filled same day received. Write for free copy now.

Standard discounts to dealers, set builders, agents. Barawik Co., 129 N. Jefferson St., Dept. 808B, Chicago, U.S.A.

# "Ionized Helium"



List Price \$4.50

RAYTHEON TYPE BH

## THE SECRET OF THE STANDARD REPLACEMENT TUBE for B' ELIMINATORS

The use of Ionized Helium gives to the Raytheon "BH" Tube a superior ruggedness, a far longer life and a sustained voltage. Be sure you get a Raytheon "BH" for your eliminator when the tube needs replacing which is generally every nine to twelve months.

**Raytheon**  
LONG LIFE RECTIFYING TUBE

# TRY SUBANTENNA FREE

Enjoy Louder, Clearer Better DX at Our Risk

Why listen-in on weak, noisy, scratchy, squealy air waves when ground waves are clean, smooth and strong? Why listen to fading, jumbled-up distant reception when you can bring it in loud, sharp, and clear, like local? The New Improved SUBANTENNA—the first and only satisfactory device to pick up ground waves, completely does away with the old style "aerial" and enables any set to get distant stations that it never could get before.

### STATIC BANISHED

Ground waves are far less affected by static than air waves. Subantenna receives these practically static-free ground waves and transmits every note pure and audible. And with Subantenna you have no roof climbing as with an aerial and no risk from lightning.

Approved by Thousands of Fans and Leading Engineers John White, of Brooklyn, N. Y., plainly received both Melbourne and Sydney, Australia, on a six-tube set with a SUBANTENNA—a distance of 10,144 miles, when an "aerial" brought in nothing but noise. W. C. F. of Chicago got Havana, Cuba and Buenos Aires, S. A., on a Subantenna. Radio News, Radio Age, Radio Digest and other leading laboratories approve and recommend Subantenna. Easily and quickly installed. Never needs attention. Write at once for particulars of FREE TRIAL GUARANTEE OFFER which permits you to test the New Improved SUBANTENNA on your set entirely at our risk. Write today.

**CLOVERLEAF MFG. CO.**

2714X Canal Street

Chicago, Ill.



**TOBE**

TOBE A FILTER with any good two-ampere charge eliminates the BATTERY

Send for pamphlet for full details

TOBE DEUTSCHMANN CO., Cambridge, Mass.

the normal conductivity of the air and prevent all of the power of the emitted wave from passing on up toward the Heaviside Layer.

Fading produced by ionized areas interfering with the deflected portion of the received wave as it comes down from the Heaviside Layer.

Fading produced by earth currents and surges up the ground wire in opposition to, or partial neutralization of, the radio wave because of the attraction of passing overhead atmospheric and cloud charges.

### GOOD RADIO WEATHER

Good reception will be noted during clear and cold weather with little static disturbance.

Poor reception, as a rule, during warm and cloudy weather with much static interference. Even when distant reception is good, the noise level is too great for good reception.

Good reception, as a rule, when the direction is through an area of equal temperature, parallel to *isotherms*, or across *isobars*.

## Radio Wrinkles

(Continued from page 151)

hole for the phone cord in the side of the plug cap.

After following the directions given in the above paragraph, attach the cord to the plug and wind the cord on the roller. The roller may now be mounted under the table; the spring end is mounted in the same way as when used for a window shade; and a radio jack mounted on a wooden block constitutes the bearing for the other end. The tension is regulated in the same way as that of a window shade.—Walter Dean, Jr.

### Cuff Buttons Good Clips

THE experimenter who tries first one circuit, and then another, often finds binding posts a great inconvenience when making frequent changes of connections.

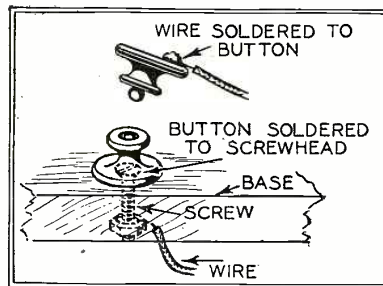

These snap-on cuff buttons make very convenient and satisfactory test connections.

A device of the type illustrated above provides a very simple solution to the problem. An old discarded pair of snap-type cuff buttons is used for the purpose, and one-half of each button is fastened to the baseboard of the set while the other half connects with a wire of the battery cable. By snapping the two halves together a good electrical connection is made, and by pulling them apart the circuit is broken. For fastening the button to the baseboard the head of a screw is soldered to the back. The back of the other half of the button is soldered to the desired lead.—J. W. Satterwhite.

# Learn ALL ABOUT AVIATION

EVERYBODY'S AVIATION GUIDE is a complete discourse on practical aviation, by MAJOR VICTOR W. PAGE, one of the leading men in the field. Unlike most books of instruction, EVERYBODY'S AVIATION GUIDE is written in a unique question and answer fashion, which makes the subject far easier to study and a great deal more attractive as an instruction course.

This book was recently published and is absolutely up-to-date in every way. It has had very favorable criticism throughout country-wide aviation circles and has been highly recommended by all those in a position to pass judgment.

We list here the contents in order that you may see for yourself how completely the field of Aviation is covered.

### Contents:

- Early Aeronautic History—First Flying Machines—The Atmosphere
- Forms of Aircraft—Airplanes and Airships
- Lighter-Than-Air Craft—Balloons and Dirigibles
- How An Airplane Flies—Elementary Aerodynamics
- Airplane Parts and Their Functions
- Fuselage Forms and Landing Gears
- Wing Arrangement and Construction
- Power Requirements, Engine Types and Engine Location
- Aircraft Propellers, Design and Application
- Airplane Equilibrium and Control
- Official World and American Air Records

Price  \$2.00

Over 248 pages  
Beautiful red cloth binding—Title in gold  
Replete with illustrations

WRITE DIRECT TO

**CONSRAD CO., Inc.**

230 Fifth Ave.

New York, N. Y.

CONSRAD COMPANY, Inc.  
230 Fifth Ave., New York, N. Y.  
Gentlemen: Kindly send me one copy of your book, EVERYBODY'S AVIATION GUIDE Enclosed find \$2.00.

Name.....

Address.....

City..... State.....

# The Listener Speaks

(Continued from page 114)

and whine, hums from chargers, leaky A.C. lines, roars from violet rays, frying noises (similar to potatoes being thrown in hot fat) from motors of different types and arcs from trolleys—and yet, *the people who want better reception are the cause of 60% of the interference.* They seem to want the penny and the candy too.

mixture is faulty with poor ignition. A good circuit is no good with poor tubes and a poor circuit will work good with good tubes.

I enclose a picture of my World's Record super; I used the loop and tight-coupled aerial for this reception. Over 3,000 miles daylight reception would seem to repay me

for an extra outlay in tubes. Let the chains broadcast all they want to; I know only one spot where it is impossible to get anything else sometimes. That is from

.....  
*Mr. Cox will meet with more envy than sympathy in his story of the joys and woes of reception.*  
 .....

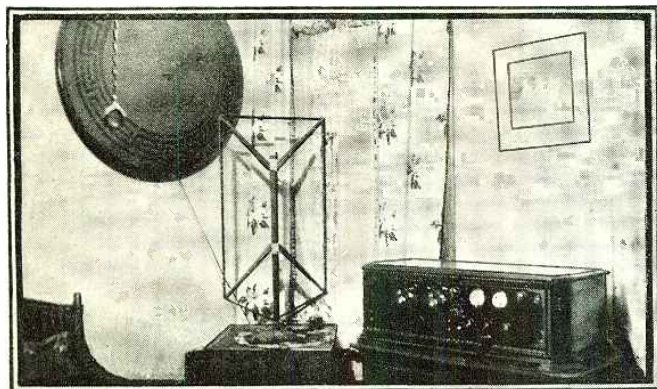

I have something, I think, that will cause a lot of 'how-come' letters; it is a verification from 2LO, London (*enclosed*) for reception at 12:44 p. m., E.S.T., and at a time which does not fall in the schedule of 5SW, its short-wave rebroadcast. To me, there is no kick in short-wave reception.

Everybody knows that a good motor is very poor with poor carburetion, and a good

WEAF, 610 kc., to WCAE, 650 kc. Try and get rid of local interference; then we can have radio.

A good many homes never see a radio magazine, and articles printed under the programs in the newspapers would be the only possible way of informing such owners of the faults of their appliances. Try and get your newspaper to run such an article. HERBERT COX, 1936 Perry St., Easton, Pa.

# What Is A Good Loud Speaker?

(Continued from page 133)

reproduction of these speakers could be greatly improved by increasing the diameter of the paper cone. Speakers of this type 36 inches in diameter were found to produce excellent results; but these were generally considered too large for home use. At present, a 24-inch speaker is being presented as a compromise between the small 16- and 18-inch sizes and the three-foot size; and it is very satisfactory. In the cone speaker, however, there are so many factors to consider that it is difficult to explain the difference between a good and a poor instrument. The quality of the paper, the design of the driving unit, the length of the driving rod, etc., all have an effect on the reproduction; and, therefore, the only way to determine the quality of a cone is by a demonstration. Fig. 8 and Fig. C clearly illustrate the construction of this type of speaker.

The free-edge cone speaker is another type which has been greatly improved recently. Such a speaker has a single cone which is attached to a "baffleboard," but not rigidly, with chamois, and is capable of excellent reproduction if correctly designed. Free-edge cone speakers need not have a large cone in order to provide good results, but they must be attached to a large baffle; as the size of the baffleboard determines the cut-off frequency. Speakers of this type set up air waves simultaneously from the front and the back of the cone, and these waves would alternately neutralize and re-

inforce each other, and seriously affect the sound, if it were not for the baffle. Therefore, as the size of the baffle is increased, the cut-off frequency is reduced.

From a theoretical viewpoint a baffleboard six feet or more across would be required in order to reproduce the lowest notes which are broadcast. However, for a cut-off frequency of 100 cycles, a much smaller baffle may be used, and this cut-off frequency is entirely satisfactory for home reception. Also, by use of a box-shaped baffle the size of these speakers may be greatly reduced. From a practical viewpoint, the free-edge cone speakers are no larger than a double fixed-edge cone which provides the equivalent in quality of reproduction.

Speakers of the free-edge cone type have several advantages not possessed by the fixed-edge type. First, they are ideally suited for mounting inside a radio cabinet; and, secondly, a short driving rod is possible and this helps to reduce distortion. Also, if correctly designed, they provide practically uniform amplification over a very wide band of frequencies. Fig. 9 illustrates the construction of two free-edge cones.

### THE TENSE-DIAPHRAGM TYPE

The linen-diaphragm speaker is one of the latest developments; and this is gaining wide popularity, because of the excellent reproduction it is capable of providing, and because it is more sensitive to weak signals

# Take the Advice of Leading Radio Service Organizations — Play Safe with PARVOLTS!

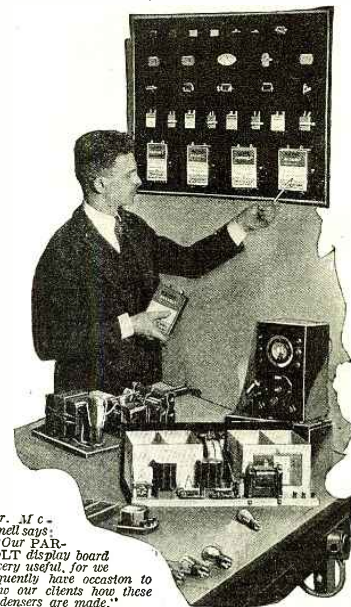

Mr. M c - Donnell says: "Our PAR-VOLT display board is very useful, for we frequently have occasion to show our clients how these condensers are made."

If you want the real truth about condensers, go to an organization that builds, services, and repairs every type of radio receiver and power supply unit.

Mr. Frank McDonell, of Rossiter, Tyler & McDonell, says:

"We think so well of ACME PARVOLT Condensers that we have samples constantly on display for all clients to see. Those of our customers who know radio also know that PARVOLTS are thoroughly reliable. We like our clients to realize that we use the best in radio."

Should a condenser blow out, many dollars would be lost in ruined tubes, transformers, chokes, and other parts. The experience of the nationally known house of Rossiter, Tyler & McDonell should be a good guide for other builders and service men to follow. Don't take any chances with condenser breakdown. Play safe with ACME PARVOLTS.



ACME PARVOLT FILTER CONDENSERS—Supplied in all standard mfd. capacities for 200, 300, 600, 1000, and 1500 Volt D. C. requirements. Uniform height and width for easy stacking. Supplied singly or in complete housed blocks for the important power supply units such as Thordarson, Samson and others.  
 ACME PARVOLT BY-PASS CONDENSERS are supplied in all standard mfd. capacities and for all required working voltages.

## ACME PARVOLT CONDENSERS Made by the Manufacturers of ACME CELATSITE HOOK-UP WIRE

Celatsite Flexible and Solid, Battery and Power Supply Cables, Spaghetti Tubing, Stranded and Solid Antenna Wire, A. C. Celatsite Wire, Loop Aerial Wire, "Pushbak" Wire, Window Lead-ins.

THE ACME WIRE CO., New Haven, Conn.

# 90 Volt Power Unit :: \$12.75

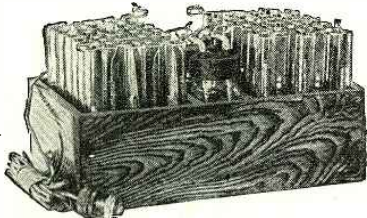

Hums, line noises, etc., positively impossible with this new advanced unit. Plug in and forget. Non-acid and noiseless. All detector and intermediate voltages plainly marked. Simpler to hook up than dry cells. Operates any type set 1 to 12 tubes. Greater volume and clearness guaranteed. If not thoroughly satisfied return after using 30 days for complete refund. Guaranteed further 2 years. For 110-120 volts A.C. 25 to 60 cycle current, 90 volts, \$12.75; 112½, \$15.25; 135, \$17.50; 157½, \$19.50; 180, \$24.00; 202½, \$26.00. Also built for D.C. current 110 and 32 volts at only \$3.00 additional, any size above. Ample stocks—same day shipments. Simply say—ship C.O.D. or write for my interesting literature, testimonials, etc.

## B. HAWLEY SMITH

334 Washington Ave. Danbury, Conn., U. S. A.

### Your Set Can Now Get Short Waves

Sent anywhere in the U. S. post paid upon receipt of price. Canada and Foreign, 50c additional. Money order only. Also sent C. O. D. plus postage in U. S. if \$1.00 accompanies order to insure carrying charges. In ordering be sure to name set and tubes used, such as UV199, UX199, WD11, 291A, UX228 or UY227. Price \$15.00 or \$17.50 for A. C. Sets.

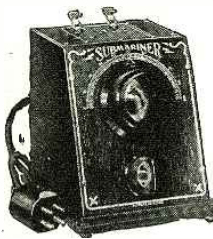

### The SUBMARINER

will convert your regular set into a short-wave receiver by simply inserting a plug in place of one of the tubes. This takes but a few seconds. With "Submariner" it will enable you to tune between 26 and 68 meters.

This device operates with all sets, such as T.R.F., Neutrodyne, Super-Heterodyne and others A.C. or D.C. operated. No additional tubes, batteries, or coils required. If set operates a speaker it will do so with "Submariner" attached. Operates a wave changer with Super-Heterodyne and as detector unit with others.

### SHORT-WAVE RECEPTION

is practical, and especially in summer, as they penetrate better and there is less static. The "Submariner" waveband includes practically all Powerful Stations which Broadcast Programs. You may also listen to amateurs from all parts of the world who transmit code messages. You will have one of the most efficient short-wave receivers when the "Submariner" is attached to your set. Get a "Submariner" so you may have command of the short-wave activities as well as the broadcast band. If your Dealer does not carry

### ORDER TODAY DIRECT

This device has been nationally advertised, and sold in all parts of the world for the past two years

J-M-P MANUFACTURING CO., INC.  
Department 53 Milwaukee, Wis., U. S. A.

## NEW SHIELDED SUPER-10

5 Screen Grid R. F. Amplifiers  
4 Stage Power A. F. Amplifier  
Illustrated literature gratis  
Complete Constructional Blue Prints,  
\$2.00, postpaid

### NORDEN-HAUCK, INC.

Builders of Highest Class Radio Apparatus in the World  
Marine Bldg., Philadelphia, Pa.  
Cable Address "NORHAUCK"

## PATENTS

As one of the oldest patent firms in America we give inventors at lowest consistent charge, a service noted for results, evidenced by many well known Patents of extraordinary value. Book Patent-Sense, free.  
Lacey & Lacey, 631 F St., Washington, D. C. Estab. 1869

than many other types of reproducers. These speakers resemble a drum more nearly than any other instrument. They consist of two square diaphragms of stretched linen on parallel wooden frames, with the centers of the diaphragms drawn together and connected to a loud-speaker unit at this point. The frames are usually mounted about eight inches apart and their usual size is twenty-four inches square. The diagram in Fig. 10 clearly illustrates the construction.

Speakers of this type possess several important mechanical features. Because the two diaphragms are perfectly balanced, the slightest vibration of the loud-speaker unit will produce an audible sound. Also, the fact that the diaphragms are balanced improves the quality of reproduction; as the load on the driving rod of the speaker unit is equal in both directions. Another interesting fact is that the highly-taut diaphragms make it almost impossible to overload the speaker, even with a large power amplifier; and this avoids the rattling which is so frequently experienced with cone-type speakers.

### THE ELECTRODYNAMIC SPEAKER

The electrodynamic-cone speaker is another type of speaker which is now gaining rapid popularity. This speaker has been designed especially to enable fans to realize the full advantages of power amplification. Fig. 11 and Fig. D show the construction.

The difference between the electrodynamic speaker and the more familiar free-edge cone speaker is not in the construction of the cone; for these are of identical design, but in the construction of the loud-speaker unit. The electrodynamic loud-speaker unit operates on a different principle from the permanent-magnet type which is used in all of the other speakers discussed in this article. These speaker units possess valuable characteristics found only in this type of reproducer, and they avoid many of the faults of the permanent-magnet type of units.

In electrodynamic speaker units there is a large field coil, which must be excited by an external source of direct current in order to produce the necessary magnetic force. A moving coil is freely suspended in the field of this coil and the moving coil is attached directly to a small free-edge cone. The audio-frequency currents pass through this coil and cause it to vibrate. This method of construction provides a number of advantages.

In the first place, the magnetic field in which the moving coil is suspended is of great strength and constancy, and the forces acting on the coil, which produce the sound, are dependent entirely upon the current in the coil and not upon the position of the coil in the field; also, there is no armature to over-saturate. These features result in almost complete freedom from distortion introduced by the speaker unit itself. In addition, there are other merits: the drive is applied directly to the cone, thus eliminating the necessity of a driving rod, which is a frequent cause of distortion. The speaker offers almost a pure resistance load on the power tube, as the inductance of the moving coil is very low. This results in a high "power-factor" and an impedance which varies but slightly with the frequency. Also, the motion of the coil is across the air gap and, as a result, there is no danger of its hitting the pole pieces when loud signals are being received.



-in all its phases!

Complete instruction course in three volumes. Every point of aviation efficiently and thoroughly treated. Subjects covered in these volumes—

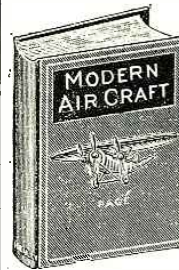

### MODERN AIR CRAFT

700 Pages  
500 Illustrations

Contents of each chapter—  
I. Aircraft Types. II. Lighter-than-Air Craft. III. Early Airplane Designs. General Design Considerations. IV. Design and Construction of Aerofoils. V. Arrangement, Fabrication and Bracing of Airplane Wings. VI. Airplane Fuselage and Landing Gear Construction. VII. Airplane Power Plant Types and Installation. VIII. Aviation Engine Design and Construction. Air-Cooled Engines. IX. Aviation Engine Design and Construction. Water-Cooled Engines. X. Aviation Engine Auxiliaries. XI. Aircraft Propeller Construction and Action. XII. Airplane Equilibrium and Control Principles. XIII. Uncrating, Setting Up and Aligning Airplane. XIV. Inspection and Maintenance of Airplanes and Engines. XV. Details of Modern Airships and Airplanes. XVI. Seaplanes, Flying Boats, Amphibians and Other Aircraft. XVII. Some Aspects of Commercial Aviation. XVIII. Aircraft Instruments and Aerial Navigation. XIX. Standard Nomenclature for Aeronautics Report No. 240, Part I.

This book is written in simple, understandable language.

PRICE \$5.00

### AVIATION ENGINES

This treatise, written by a recognized authority on all of the practical aspects of internal combustion engine construction, maintenance, and repair, fills the need as no other book does. The matter is logically arranged; all descriptive matter is simply expressed and copiously illustrated, so that anyone can understand airplane engine operation and repair even if without previous mechanical training. This work is invaluable for anyone desiring to become an aviator or aviator mechanic.

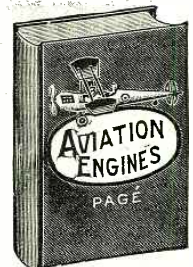

274 PAGES

PRICE \$1.25

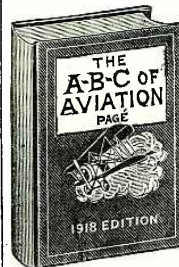

### A. B. C. OF AVIATION

This book describes the basic principles of aviation, tells how a balloon, or dirigible is made, and why it floats in the air. Describes how an airplane flies. It shows in detail the different parts of an airplane, what they are, and what they do. Describes all types of airplanes and how they differ in construction, as well as detailing the advantages and disadvantages of different types of aircraft. It includes a complete dictionary of aviation terms and clear drawings of leading airplanes.

PRICE \$1.25

Remit by cash, stamps, check, or money order  
No C.O.D.'s

We Pay Postage On All Books

CONSRAD COMPANY, Inc.  
230 FIFTH AVENUE NEW YORK

## EXCELLO Radio Consoles

A new console designed for  
RADIOLA MODEL 18  
or other receivers, either A.C. or D.C.



Excello Console  
Model R 43

Receiver compartment is a sliding drawer 29 in. x 9 1/4 in. x 12 in. deep. Ample room in speaker compartment for cone speaker and eliminator. Cabinet, walnut throughout, with fancy butt walnut veneer doors. At your Dealers, or write for complete catalog of full line.

EXCELLO PRODUCTS CORP.  
4832 W. 16th St., Cicero, Ill. (Suburb of Chicago)  
Pacific Coast representative—Pacifie Sales Corporation,  
426 Larkin Street, San Francisco, Calif.

### DEPENDABLE "B" BATTERY POWER

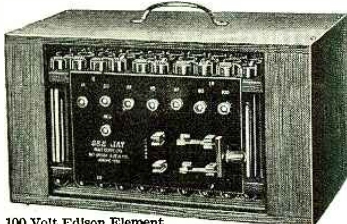

100 Volt Edison Element.  
Non Destructive, Rechargeable "B" Battery with  
charger. Shipped dry with solution, \$12. 140 Volt with  
charger, \$17. 180 Volt Power Unit with Trickle  
Charger, \$24.00. Free sample cell. See how it  
operates.

SEND NO MONEY—PAY EXPRESSMAN  
Write for our Free Illustrated 24-page Booklet  
SEE JAY BATTERY CO., 915 Brook Ave., New York

## LEARN CODE

Quickly and easily at home with the TELEPLEX Code  
Instructor. No experience necessary. Simply listen  
to expert operators send messages, radiograms, etc.—  
regular code—traffic as sent on the air. Provides practice  
when, where, and how you want it. Endorsed by  
U. S. Navy and leading schools. Complete course of in-  
structions (Wireless or Morse) for beginners and ad-  
vanced students furnished. Learn code and enjoy the  
thrill of real DX. Write for booklet NRS.

TELEPLEX COMPANY  
76 Cortlandt St. New York, N. Y.

**AEROVOX** of high  
quality  
resistors and  
condensers that are  
Built Better—to endure.  
Write for The Research Worker.  
A free monthly publication.  
AEROVOX WIRELESS CORPORATION  
68 Washington Street Brooklyn, N. Y.

**AMRAD**  
MERSHON CONDENSERS  
For full information address Department RN.

## Circuit Changes on the Neutroheterodyne

SINCE publishing a series of three ar-  
ticles describing the theory, construc-  
tion and operation of the Reich Neutro-  
heterodyne receiver and its power unit (in  
the May, June and July numbers), RADIO  
NEWS has received a considerable number of  
letters from readers who desire further in-  
formation on the circuit. Many of these  
contained simple questions about the con-  
struction of the set, but others suggested  
changes and improvements and requested  
our opinion on revised arrangements. There-  
fore, this article will consider the most  
popular queries received, for the benefit of  
those who are interested in the set but did  
not write in. Also, it will describe a cir-  
cuit improvement perfected by Mr. Reich  
since the publication of his article.

### SCREEN-GRID TUBES NOT ADVISED

Probably the question most frequently  
asked us regarding the Neutroheterodyne  
receiver is this: "Is it advisable to redesign  
the set to permit the use of 222-type  
(screen-grid) tubes in the intermediate-  
frequency amplifier stages?" In this con-  
nection it may be explained that the use of  
screen-grid tubes in place of 201A-type  
tubes in the intermediate stages of a re-  
ceiver may result in one of two possible ad-  
vantages: either an increase of amplifica-  
tion, or a decrease in the number of tubes.  
On the other hand, when used with 201A-  
type tubes, the Neutroheterodyne, as now  
designed, at all times gives more than ample  
sensitivity and volume. Gaining additional  
sensitivity per stage, by use of 222-type  
tubes, in order to make possible the elimi-  
nation of one intermediate stage without re-  
ducing the range of the receiver, is not en-  
tirely satisfactory; as the selectivity of the  
receiver would be impaired to an undesir-  
able point. There would, therefore, be no  
real advantage in the use of 222-type tubes,  
and their use would introduce a number of  
needless complications. These tubes, also,  
tend to be very microphonic.

### 199-TYPE OSCILLATOR

The type of the tube used in the oscil-  
lator stage also attracted some attention.  
In the text and list of parts in the second  
installment of the article, it was stated that  
either the 201A- or 199-type tube may be  
used satisfactorily in this position; and sev-  
eral experimenters have found that better  
results are obtained with the 201A-type. It  
is true that the coils of the set were de-  
signed especially for a circuit using a 201A-  
type tube and, when a 199-type tube is used  
in the oscillator stage, there is some reduc-  
tion in signal strength on long-wave sta-  
tions. Also, the dials do not remain per-  
fectly synchronized on all waves.

If it is desired to use a tube of the 199-  
type permanently in the oscillator stage, it  
will be best to reconstruct the oscillator  
coupler. Adding five turns of wire to each  
winding of the coupler will make it possible  
to obtain the same efficiency with a 199-type  
tube as from a 201A-type with the original  
coil. Also, the use of a 199-type tube in  
this position effects a reduction in the fla-  
ment current required for the receiver.

When building the power unit for the re-  
ceiver, it may be found necessary to reduce  
its size slightly in order to fit it into a con-

# For Better, Clearer Radio Reception



CECO  
PRONOUNCED  
SEE-CO  
RADIO  
TUBES

# CECO Radio Tubes

AGAIN CeCo blazes the  
trail in radio engineering  
achievement by introducing  
the popular Screen Grid Tube  
in an A.C. type:—the AC22.

The CeCo line of A.C. tubes  
is most complete, embracing  
practically every existing type

CeCo Tubes are carried in stock  
by dealers everywhere. Write  
us for unusual and interesting  
booklet entitled "Getting the  
most out of your Radio."

**CeCo MANUFACTURING Co. Inc.**  
PROVIDENCE, R. I.

**AMAZING STORIES  
QUARTERLY**

AMAZING STORIES QUARTERLY, a big, intensely interesting magazine of truly remarkable tales, is on the newsstands ready for the public to grasp and enjoy. AMAZING STORIES QUARTERLY is a book full of tales of interplanetary communication—not foolish impossible fiction, but "scientifiction"—fiction with a plausible scientific background. Tales of other worlds—of strange people—of weird happenings—of the future—this is what AMAZING STORIES QUARTERLY brings its readers. Only those who have read it can fully appreciate the value of this remarkable magazine. Words fall far short in describing, with the smallest degree of accuracy, the true nature of AMAZING STORIES QUARTERLY.

Stories by some of the best-known authors of the day—gripping narratives well worth reading. You will not want to miss this outstanding quarterly issue of AMAZING STORIES. There are many hours of pleasant reading awaiting you.

**AMAZING STORIES QUARTERLY**  
Over 144 pages—fully illustrated  
Large 9-in. x 12-in. size  
AT ALL NEWSSTANDS OR WRITE DIRECT

THE **50c** COPY

Experimenter Publishing Co.  
230 FIFTH AVENUE  
NEW YORK, N. Y.

sole cabinet. It is possible to make the power unit somewhat smaller by removing two of the parts and placing them in the receiver. The first-detector "B" choke may be mounted above the first audio transformer in the receiver, instead of in the power unit, and this arrangement will not affect the efficiency of the circuit in any way. In addition, if preferred, the output choke coil may be mounted in the receiver, over the second audio transformer. Because of the limited space, it will be necessary, however, to use a choke coil having smaller mechanical dimensions. A choke of the type used in the first-detector "B" circuit may be employed for the purpose.

In operating the receiver, with the first-detector "B" choke mounted in the power unit, if a fairly loud 60-cycle hum is heard at all times in the loud speaker, it probably is caused by stray fields from the power transformer, which are picked up by the choke coil. In order to eliminate this hum the choke coil should be turned about until best results are secured. If it is found impossible to eliminate the hum entirely, it may be necessary to place the choke coil in the receiver as described in the preceding paragraph. Also, the power unit should be placed at least three feet from the receiver wherever possible.

**ADJUSTMENT OF I.F. TUNING**

An important operating kink has to do with the connections to the adjustable condensers which are used to tune the intermediate-frequency transformers of the receiver. One terminal of each condenser makes electrical contact with the adjusting screw; to prevent detuning during adjustment, it is essential that this terminal be connected to the transformer terminal R, and not to G. Also, it will be noticed that these condensers change slightly in capacity with their temperature. It is, therefore, best to adjust the receiver carefully after the set has been in operation for several hours, and has warmed up completely. Also, it is well to check this tuning occasionally.

**A RECOMMENDED CHANGE**

Since the publication of his article on the Neutroheterodyne in the June issue of RADIO NEWS the designer of the set found that a considerable improvement can be made by a slight alteration of the circuit. In the original circuit, the oscillator pick-up coil, which is in the secondary circuit of the first detector, is not included in the tuned portion of that circuit, and therefore responds to its own natural frequency. It may happen very readily that this frequency corresponds to that of a short-wave transmitter; and in this case a small amount of energy from an undesired station will be superimposed upon the carrier of the desired station. Harmonics from the oscillator may heterodyne an undesired station to the intermediate frequency, resulting in an audio-frequency heterodyne whistle. This trouble may be prevented entirely by including the coupling coil in the tuned portion of the detector secondary circuit; so that it will respond only to the frequency of the desired station, and not to its own natural frequency.

It is a very simple matter to make this change, as only one connection is altered in the actual wiring. The frame (rotor plates) of the first-detector tuning condenser is connected to the shielding instead of to the terminal R of the first-detector transformer; while R connects to the O termi-

**Use Your Radio More!**

THOUSANDS of homes get more use of their radio because of the exceptional economy and dependability of our "B" and "AB" equipment. A safe investment in tone quality, selectivity, extreme dependability and economy. For heavy duty service on all types of receivers. Write for free trial offer and guarantee. Made for all power lines, including farm plants. WRITE!

**KIMLEY ELECTRIC CO.**  
441 East Ferry St. Buffalo, N. Y.

Natural Tone

**Majestic Cone**

Designed for use with or without power tubes  
Reproduces music or voice exactly as it comes from the broadcasting station. A full, rich, pure tone, free from distortion.

A beautiful cone, 16 in. in diameter, ruggedly constructed, laminated wood frame and metal base, with sensitive, adjustable unit, finished in rich mahogany. Packed individually in fibre air-cushion cartons. Standard package of 6.

PRICE, EACH \$2.75

Write for Other Special Bargains Now to  
**SPIEGEL RADIO COMPANY**  
135 Liberty Street New York City, U. S. A.

**TERMS:** 2% Discount Allowed on C.O.D.  
3% Discount If Cash Is Sent With Order

Quality Apparatus  
Our latest bulletin No. 929 describing our complete line of quality apparatus is yours for the asking. Write for it today.  
**GENERAL RADIO CO.**  
30 State St., Cambridge, Mass.

**6 TUBE SUPERPHONIC RADIO—\$16.95**  
FREE—Six tubes, tested and matched  
An amazing value that can't be beat! Latest 6-tube tuned radio frequency circuit. Metal chassis, shielded. Extremely selective. Long-distance reception. Send for complete descriptive circular. Value \$60, our price \$16.95. Write today.  
**Radio Equipment Co., D. 12H 545 S. Wells St., Chicago, Ill.**



nal of the oscillator coil, as before. See page 1339 of the June issue of RADIO NEWS. With this arrangement, it is obviously unnecessary to insulate the variable condenser from the panel shield or to substitute a bakelite shaft for the regular brass condenser shaft. It is necessary, however, to reduce the number of secondary turns from 70 to 60.

## Learning the Code

(Continued from page 155)

We are listing a number of the most widely-used intermediates.

AI—India	NM—Mexico
AJ—Japan	NO—Cuba
EI—Denmark	NU—United States of America
EE—Spain	OA—Australia
EF—France	OD—Dutch East Indies
EG—Great Britain	OI—Hawaiian Islands
EI—Italy	OP—Philippine Islands
EM—Sweden	OZ—New Zealand
EN—The Netherlands	SA—Argentina
ES—Finland	SB—Brazil
EU—U.S.S.R. (Russia)	SC—Chile
FO—Union of South Africa	SL—Colombia
NA—Alaska	SP—Peru
NC—Canada, Newfoundland	SU—Uruguay
	SV—Venezuela

These intermediate signals are used as follows: British station INJ when calling U. S. station 2BV would send: "2BV 2BV 2BV nucg 1NJ 1NJ 1NJ." The American station answers: "1NJ 1NJ 1NJ egnu 2BV 2BV 2BV." When two stations in the same country are communicating, the following system is used: "6ABD 6ABD 6ABD nu 1BR 1BR 1BR."

The call letters of the amateur stations in the United States are all prefixed by numbers. The United States is divided into nine radio districts, each in charge of a radio inspector of the Department of Commerce. These numbers indicate the district and, therefore, the part of the country in which a station is located. The first, second, third and fourth districts are on the Atlantic coast. The fifth, eighth and ninth are in the Central states and the sixth and seventh on the West coast. These divisions are of great assistance to the beginner when listening in since, even though the complete call is not understood, the number indicates the approximate position of the station.

### SECRECY

Section 27 of the Radio Act of 1927 provides:

"No person not being authorized by the sender shall intercept any message and divulge or publish the contents, substance, purport, effect or meaning of such intercepted message to any person; and no person having received such intercepted radio communication or having become acquainted with the contents, substance, purport, effect or meaning of the same or any part thereof, knowing that such information was so obtained, shall divulge or publish the same or any part thereof, or use the same or any information therein contained for his own benefit or for the benefit of another not entitled thereto; *Provided*, that this section shall not apply to the receiving, divulging, publishing or utilizing the contents of any radio communication broadcast or transmitted by amateurs or others for the use of the general public or relating to ships in distress."

The penalties provided in the Act for

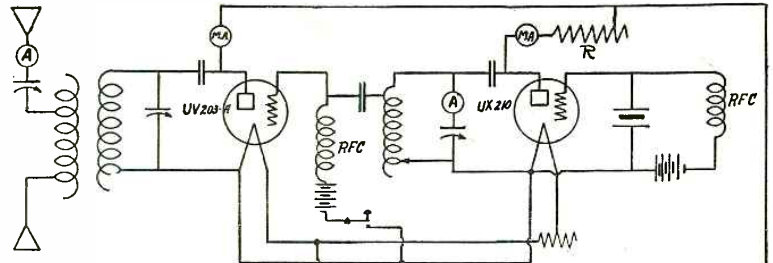

THIS shows a medium power crystal controlled transmitter using UX210 crystal controlled tube feeding a UV203-A power amplifier. Filament and plate voltages are to be obtained from Item 34, operating from either DC or AC house mains. The voltage to the filament of the tubes is variable, either by the field resistor in the filament generator circuit (not shown) or by the resistance in the filament circuit of the UX210 tube. Keying is done in the bias circuit of the 203-A power amplifier. As the amplifier is NOT neutralized, the power amplifier must work on some harmonic of the crystal tube [preferably the second], for all operations in the 20, 40 or 80 meter bands. A crystal having a fundamental of 160 meters will allow operation in all bands with best output in the 80 meter one. An 80 meter crystal is best for 40 meter operation and in like manner the 40 meter crystal would be best for 20 meter operation. Forty meter crystals are hard to get and blow up easily, so for 20 meters the 80 meter crystal is used again. Both tubes obtain plate supply from the plate end of Item 34, the UX210 being supplied with not over 350 volts through resistance R, and the 203-A taking the full 1000 volts.

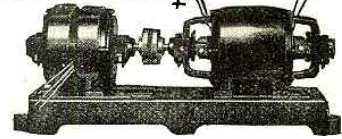

## ELECTRIC SPECIALTY COMPANY

211 South Street TRADE "ESCO" MARK Stamford, Conn., U.S.A.  
Manufacturers of Motors, Generators, Motor-Generators, Dynamotors and Rotary Converters for Radio and other purposes

## A NEW and BETTER SHORT WAVE RECEIVER THE AERO INTERNATIONAL FOUR

THIS new Aero Receiver embodies many noteworthy improvements. Uses latest design Aero Interchangeable Coils that provide increased efficiency of operation. Sensitivity has been increased, control made easier, noises eliminated. Particularly adapted to musical broadcast.

### Uses New Kit

The coils illustrated are the L.W.T., 10 Kit, price \$10.50. Designed for use with special foundation unit which includes mounting base. These new coils are only 2 in. in diameter, insuring smaller external field and better performance.

### Get Literature

Investigate this set today. Write for complete descriptive literature NOW. Address:

**Aero Products, Inc.**  
Dept. 105  
1772 Wilson Ave. Chicago, Ill.

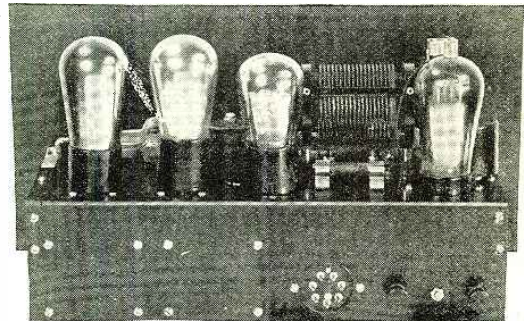

(Rear Panel View)

### NOTICE

We can furnish all parts for this new receiver, including foundation unit, direct from factory. Write for information and complete kit price list.

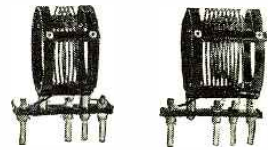

## DOLLAR SPEAKER FILTER

Relieves speaker of plate DC (180 to 250 volts). Complete Protection. One dollar postpaid.

Craftsman Radio Products  
9 Orchard St., Newark, N. J.

## A-C FILAMENT TRANSFORMER

Supplies stepped down current from 110 volt 50-60 cycle lines for six type 226 tubes, two type 227 tubes, and two type 71 tubes. Guaranteed. Only \$4.87. Order today. Money back if not satisfied.

Illinois Transformer Co. 223 W. Elm St. Dept. 105, Chicago

## EVERYTHING IN RADIO

AT ATTRACTIVE PRICES. SETS OR PARTS. Orders shipped exactly as ordered. Prompt Service. Write for Prices. Mail Order Only. Send Your Address. ALL RADIO COMPANY, 417 North Clark St. Chicago.

## SET BUILDERS BIG DISCOUNTS

Big New 1928 Catalog — Shows latest A-C circuits, newest ideas. 4000 leader. Get sets and parts you want here. Save money. Parts, kits, complete factory-built sets, supplies. Quick service. Write for free copy. Standard discounts to dealers, set builders, etc. Barawik Co., 129 N. Jefferson St., Dept. 808, Chicago, USA.



E.C.A. "A" Eliminator, 60 cycle, 110 v. output 2½ amps. 6 v. No Battery—SILENT—\$16.00; "B" Eliminators, 150 v. 40 mills, 4 taps, with 280 bulb, \$10.00; Model KW, 180 volts, 60 mills, 5 taps, 280 bulb, \$11.75; 5-v. taps for power tube filaments. "ABC" Eliminator, one unit, 2½ amps., 6 v. "A" side, 180 v., 5 taps, 60 mills "B." 4.5 v. 40 volts "C." Complete, \$20.00; 2-amp. "Z" metal electrolytic charger, \$6.50; trickle charger, \$2.75; 2-amp. screw base DRT rectifier, \$2.25; Speaker output filter—protects speaker—\$1.50; Under-ground aeriels, \$2.75. Dealers wanted. ELECTRO-CHEMICAL COMPANY OF AMERICA, Indianapolis, Indiana.

## FORMICA KIT PANELS

Drilled and decorated for leading kit sets are available through leading jobbers everywhere.

THE FORMICA INSULATION COMPANY

4614 Spring Grove Avenue, Cincinnati, Ohio



# AMAZING STORIES

## Tales of Interplanetary Communication

A big fine collection of "SCIENTIFCTION"—fiction with a plausible scientific background—can be found each month of the year in this intensely interesting book, **AMAZING STORIES**. These stories, written by such well-known authors as Jules Verne, H. G. Wells, Miles J. Breuer, Earl L. Bell, and many others equally famous, form an agreeable change from the more or less cut-and-dried literature of the day.

Tales of interplanetary communication, exciting, vivid stories that pique the imagination and carry one away to distant realms and strange people. Read about the future—about other planets and their inhabitants. Let **AMAZING STORIES** carry you through many adventures. You will be able to live these stories. You will find yourself actually playing a part in each adventure.

*Don't neglect to get your copy.*

Over 100 pages—fully illustrated. Large size magazine.  
 AT ALL NEWSSTANDS OR WRITE DIRECT  
**EXPERIMENTER PUBLISHING CO.**  
 230 FIFTH AVE. NEW YORK CITY, N. Y.

# 25c

THE COPY

violation of any provision are a maximum fine of \$5,000 or imprisonment for not more than five years, or both.

Because of the above provisions of the Radio Act, it is necessary to be very careful in the matter of telling others of messages heard with a radio receiving set. Of course, most amateur messages are more or less of a personal nature and really do not interest other people except in the matter of hearing both sides of the conversation. When listening to commercial stations or, especially, those of the government, absolute secrecy must be maintained.

As a review of the system used for learning the code, it is necessary: first, to memorize the letters making up the code in the way they sound, rather than the way they appear. In other words, use the "dit, darr" system. It is then necessary to practice receiving slow messages in order to increase the reception speed until any message can be understood. Next learn the various abbreviations and signs used in transmission and, finally, sit back in your chair and thoroughly enjoy all of the activity on the short-wave bands.

### A Screen-Grid Short-Wave Receiver

*(Continued from page 145)*

of the secondary coil. The tickler winding T consists of a few turns of wire wound 1/4-inch below the end of the primary winding. This method of construction is clearly illustrated in Fig. 2.

In constructing home-made coils provision may be made for using the same type of socket receptacle if desired. This socket consists of a bakelite disc with a maximum diameter of 4 1/4 inches. A circular hole, 2 1/16 inches in diameter, is cut in the center of this disc, for the coils to fit into. Six contact springs of phosphor bronze or spring brass are mounted at equal distances apart around the circumference of the smaller circle, and these springs make contact with the contact screws of the plug-in coils. Also, a locating lug, which fits into a slot of each plug-in coil, is mounted on the base to insure that the coils shall be inserted in the socket in the proper manner. The method of constructing the base is clearly shown in the constructional drawings.

Before winding the coils, it is necessary to drill six holes at one end of each of the coil forms. These holes are for the connecting screws which are the means of providing contacts between the coil and the coil socket. They are spaced equally on the circumference of the coil form, and 1/4-inch from the end of the tube. After the holes have been drilled, machine screws should be fitted into them, with the head of the screw on the outside of the coil form and a nut on the inside to hold the screw in place. Now, place a number alongside each screw, starting with 1 and continuing in a clockwise direction until the last screw is numbered 6. Next, between screw terminals numbers 1 and 6, cut a slot 1/2-inch long and 1/8-inch wide in the tube. This slot fits over the locating lug of the coil socket. Also, as a further precaution, a check may be located between the terminals 3 and 4 to support the tube on the other side. This check may be a short machine screw.

In winding the 15-meter coil, the second-

## "CHI-RAD"

*Write for special proposition on*

**Madison-Moore AC One-Spot  
 Nine-in-Line-Super  
 Remler 115 KC Super  
 and the Tyrman 70**

Complete parts in stock. Dealers and set builders write for discounts.

### NEW SHORT-WAVE COILS

Specially built by "Chi-Rad." Write for descriptive bulletin and catalog. Dealers and set builders please use business letterhead when writing for discounts.

**Chicago Radio Apparatus Co.**  
 415 S. Dearborn St., Dept. RN, Chicago

## \$75 to \$125 Weekly

### Charging Batteries Starts You



Let me show you how to make big money right from the start. I've prepared a **FREE** book explaining all details. First week's profit pays for all equipment. You can get all the battery charging business in your community with my Service Station Charger—it's years ahead of ordinary chargers—handles 50% to 70% more batteries. I explain everything—start you in a business of your own and put you on the way to big money. Write for **FREE BOOK**.

**C. F. HOLMES, Chief Engineer, Dept. R.N.**  
 Independent Electric Works  
 5116 Ravenswood Ave. Chicago, Ill.

## FREE BOOK—Just Out

**Big Profits**

ary winding should consist of 4 turns of No. 14 enameled wire spaced the equivalent of one turn apart. The primary coil consists of 4 turns of No. 26 enameled wire, wound between the turns of the secondary winding. The tickler coil is wound  $\frac{1}{4}$ -inch below the secondary winding and consists of 2 turns of No. 26 D.S.C. wire. All coils are wound in the same direction.

The other coils are of similar construction to the 15-meter coil described above. The 40-meter coil has 7 turns of No. 14 enameled wire on the secondary, 6 turns of No. 26 enameled wire on the primary and 2 turns of No. 26 D.S.C. wire on the tickler. The 65-meter coil has 14 turns of No. 14 enameled wire on the secondary, 13 turns of No. 26 enameled wire on the primary and 3 turns of No. 26 enameled wire on the tickler. The 115-meter coil has 24 turns of No. 16 enameled wire on the secondary, 24 turns of No. 26 enameled wire on the secondary and 4 turns of No. 26 D.S.C. wire on the tickler.

After the four coils have been wound, connections should be made between the ends of the coil and the contact screws mounted at the base of the coil form. Terminal No. 1 connects with the beginning of the primary winding, that is, the end of the winding nearest the base of the coil form; terminal 2 connects with the other end of the primary; terminal 3 connects with the beginning of the secondary winding which is adjacent to the beginning of the primary winding, and terminal 4 connects with the end of the secondary winding. Terminals 5 and 6 connect with the tickler winding; terminal 5 with the end of the winding which is nearest the base, and terminal 6 with the end nearest to the primary and secondary windings.

**WIRING SIMPLE**

The arrangement of parts on the base-board is shown clearly in Fig. 3 and Figs. B and C. This placement of parts is probably the simplest from the wiring viewpoint, but it is not essential that it be followed

exactly. Good results may be obtained from any arrangement of parts which does not greatly lengthen the wiring required in the R.F. circuits. All of the parts are held in place with wood-screws, with the exception of the variable condenser (C1) which is secured in place by two machine screws which pass through the base.

Binding posts are not used in the power circuit of the set, but the wires of the battery cable are connected directly to the proper terminals in the set. This method greatly facilitates connecting the set to the batteries. In the pictorial and schematic wiring diagrams, a color code is given for the battery cable; but any other code will be just as satisfactory. Also, if the cable has more than the six required wires, three wires may be soldered together in order to provide separate leads for the "A-," "B-" and "Ground" connections.

Ability to obtain good results from the receiver may be gained only by practice in tuning the set. Until the operator has had a little experience it might be well to practice adjusting the coils for the short-wave program of KDKA, which is broadcast on a wavelength of 62.5 meters. This station will be received when using the 37.5-to-65-meter coil. Probably the simplest way to tune in a telephone station is to make the detector tube oscillate by adjusting the volume-control resistor (R4); and then the carrier wave of the station will be received when the variable condenser (C1) is set at the correct position. After the carrier-wave has been located, a slight adjustment of the two knobs should bring in the station. However, it should be remembered that the tuning of a short-wave receiver is much more critical than that of a standard broadcast receiver and, unless care is exercised, the novice is likely to pass right by a station when turning the dial.

**Radio News Laboratories**

(Continued from page 159)

**POWER TUBES**

The "L.S. 171A" vacuum tube, submitted by the La Salle Radio Corp., 149 W. Austin Ave., Chicago, Ill., is of the power type, and designed to be used in the last stage of an audio-frequency amplifier. It has a coated filament which operates normally at dull red heat, and requires  $\frac{1}{4}$ -ampere at 5 volts. The static characteristics of this tube are



of standard type. Its dynamic characteristics, with 90 volts on the plate and a bias of -6 volts, are as follows:

- Amplification constant—3.19
- Plate impedance—2,000 ohms
- Mutual conductance—1,600 micromhos.

The normal plate operating voltage is between 90 and 180, and a grid-bias up to minus 40 volts is required. This tube is equipped with a standard UX base.

AWARDED THE RADIO NEWS LABORATORIES CERTIFICATE OF MERIT NO. 2370.

The "L.S. 112-A" vacuum tube, submitted by the same company, is of the power output type, and equipped with a standard UX base. Its dynamic and static characteristics are those of standard tubes of the same type. Like the "L.S. 171A" type, this tube has a coated filament which is normally operated with a  $\frac{1}{4}$ -ampere at 5 volts. Its dynamic characteristics (average of three tubes) with 90 volts on the plate and -3 on the grid, have been found to be:

- Amplification constant—7.14

**SKINDERVIKEN Transmitter Units**

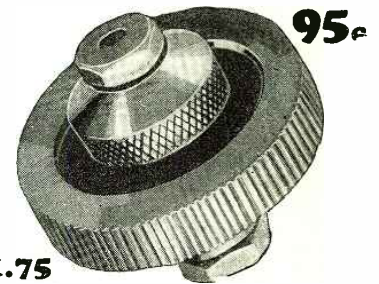

Two for \$1.75

Have hundreds of uses. Every amateur should have two or three of these amplifiers in his laboratory.

**A FEW USES FOR THESE UNITS**

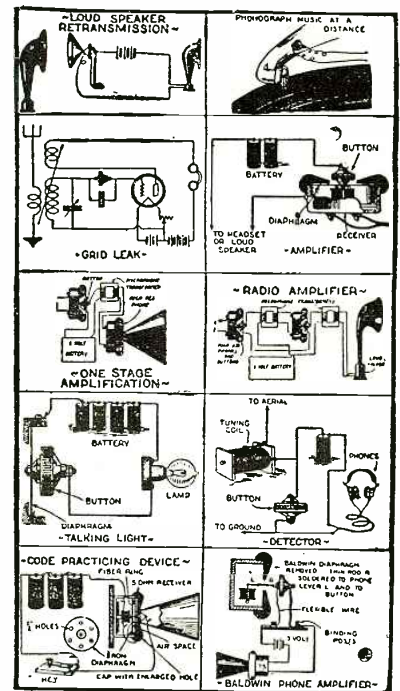

12 PAGE INSTRUCTION BOOKLET containing suggestions and diagrams for innumerable uses, furnished with each unit.

**WE PAY \$5.00 IN CASH**

for every new use developed for this unit and accepted and published by us.

**P. G. MICROPHONE TRANSFORMER**

A Modulation Transformer specially designed for use with the Skinderviken Transmitter Unit. Has many other uses. Primary resistance  $1\frac{1}{4}$  ohms. **\$2**

**FOR SALE AT LEADING DEALERS**

Or Order Direct, Using Coupon Below

**SEND NO MONEY**

When the postman delivers your order you pay him for whatever you have ordered, plus a few cents postage.

PRESS GUILD, INC. 16-18-R—East 30th St., New York, N. Y. R-8-28

Please mail me at once as many of the following items as I have indicated.  
 ..Skinderviken Transmitter Units at 95c. for 1; \$1.75 for 2; \$2.50 for 3; \$3.20 for 4.  
 ... P. G. Microphone Transformers at \$2.  
 When delivered I will pay the postman the cost of the items specified plus postage.

Name.....

Address.....

City.....State.....

**40 Non-Technical Radio Articles**

every month for the beginner, the layman and those who like radio from the non-technical side.

SCIENCE AND INVENTION, which can be bought at any newsstand, contains the largest and most interesting section of radio articles of any non-radio magazine in existence.

Plenty of "How to Make It" radio articles and plenty of simplified hook-ups for the layman and experimenter. The radio section of SCIENCE AND INVENTION is so good that many RADIO NEWS readers buy it solely for this feature.

**Radio Articles Appearing in August Science and Invention Magazine**

- RADIO BEACON GUIDES PLANES
- SUMMER PORTABLE RECEIVERS
- ALL ABOUT LOUD SPEAKERS
- NEW RADIO DEVICES
- RADIO ORACLE
- RADIO WRINKLES
- LATEST RADIO PATENTS

# 8 POPULAR MODERN MOVIE NOVELS \$1.00

## GREATEST OFFER EVER MADE

Take Advantage of This Amazing Bargain

Eight full size books for one dollar. Never before has an offer of this kind been made. Only quantity production permits us to make this astounding offer now. Take advantage of it while you have the opportunity. Needless to say these modern up-to-date movie hits cannot last long at this tremendous bargain price. Each book contains at least two color "stills" of an actual scene from the photoplay. Don't hesitate. Mail this coupon now. Every story based on an actual moving picture triumph. The greatest book bargain of the age.

Titles of This Tremendous Bargain Offer

1. New York
2. The Campus Flirt
3. Almost a Lady
10. Sensation Seekers
11. The Rambling Rangers
12. Don't Tell the Wife
14. Tracked by the Police
15. Tell It to the Marines
19. Irresistible Lovers
20. The Cohens and Kellys In Paris
21. The Divine Woman
22. Jazz Mad
23. The Crimson City
24. You Can't Beat the Law
25. Tillie's Punctured Romance
26. Forbidden Hours

8 BOOKS FOR \$1.00  
Your Choice

An Addition To Your Library

These books will be a worthwhile addition to your library. You will find many hours of truly enjoyable reading in each beautiful volume. Printed on fine paper with large clear type. Beautiful colored covers of flexible durable material. These books are undoubtedly one of the greatest values ever offered at this amazingly low price.

Write Now! Don't Wait! This bargain cannot last long at this price

CONSRAD COMPANY, INC.

230 FIFTH AVENUE

NEW YORK, N. Y.

CONSRAD COMPANY, INC., 230 Fifth Avenue, New York, N. Y.

Gentlemen: Enclosed find \$1.00. Kindly send me the books listed by number herewith:

Numbers.....

Name.....

Address.....

City.....State.....



**HOOK-UP BOOK FREE**

Improve your reception with **CARBORUNDUM Stabilizing Detector Units, Grid Leaks and Resistors**

THE CARBORUNDUM COMPANY  
DEPT. D-1, NIAGARA FALLS, N. Y.

**RADIO PANELS BAKELITE—HARD RUBBER**

Cut, drilled, and engraved to order. Send rough sketch for estimate. Our Complete Catalog on Panels. Tubes and Rods—all of genuine Bakelite or Hard Rubber—mailed on request.

STARRETT MFG. CO.  
520 S. GREEN STREET - CHICAGO

**BIG DISCOUNTS TO SET BUILDERS**

Big New 1928 Catalog—4000 Bargains—Latest A-C circuits, newest ideas in radio, at startling low prices. The sets and parts you want. Save money. Best parts, kits, complete factory-built sets, supplies. Orders filled same day. Write for free copy. Standard discounts to dealers, set builders, agents. Dept. 888A, Barawick Co., 129 N. Jefferson St., Chicago, U.S.A.

**The ELECTRIC Radio Freshman EQUAPHASE**

at All Authorized Dealers

Plate impedance—4,400 ohms  
Mutual conductance—1,750

The normal operating voltages are: Plate voltage, 22½ to 160; grid bias, up to — 10 volts.

AWARDED THE RADIO NEWS LABORATORIES CERTIFICATE OF MERIT NO. 2371.

**VOLTAGE REGULATOR**

The voltage regulator submitted by the Central Radio Laboratories, 16 Keefe Avenue, Milwaukee, Wis., is designed to keep the input power voltage of an A.C.-operated receiver as close as possible to its rated value. Because of fluctuations of the line voltage, often very considerable at different hours, the filaments of the tubes of an A.C. receiver many times operate at higher voltages than rated, and lose very quickly their efficiency or their emissive power.

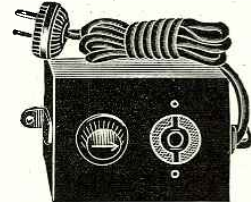

This regulator remedies this evil; it consists of a sturdy large-dimensioned air-cooled rheostat which is placed in series with the A.C. power input circuit of the receiver. The resistance value of the rheostat is approximately 65 ohms, which secures a maximum drop of approximately 15 to 20 volts. The rheostat, with an additional socket, is built into a metal box 4 x 3 x 1½ inches. A five-foot cable serves to connect this regulator to the lighting receptacle.

AWARDED THE RADIO NEWS LABORATORIES CERTIFICATE OF MERIT NO. 2372.

**HIGH-RESISTANCE POTENTIOMETER**

The type 2882 high-resistance potentiometer, submitted by Herbert H. Frost, Inc., 160 North La Salle St., Chicago, Ill., is of the roller-contact type, and similar in construction and operation to their type 1890, described in the April issue of RADIO NEWS, to which Certificate of Merit No. 2286 was

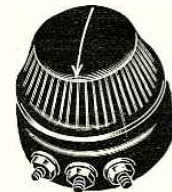

issued. This potentiometer is smaller in dimensions (1½ inches in diameter), and has a housing of black molded bakelite, instead of nickel-plated brass, like the previous model.

AWARDED THE RADIO NEWS LABORATORIES CERTIFICATE OF MERIT NO. 2373.

**RESISTORS**

The "Megite" ("Ohmite") resistors shown, submitted by the Graham-Farish Manufacturing Co., 17, Masons Hill, Bromley, Kent, England, are molded of a highly-resistant composition. The resistivity of this compound varies within wide limits and, therefore, resistors from 10,000 ohms up to several megohms are obtained with the same physical dimensions. Two "Megite" resistors, having nominal values of 3 and 0.25 megohms, have been tested with different voltages varying from 1 up to 80. The variation of their resistance values has been found to be very small, less than 1 per cent.



A 10,000-ohm unit ("Ohmite") was tested and showed a maximum variation of 7 per cent. This type of resistor is equipped with screws and nuts and fits in any standard ¼-inch grid-leak mounting.

AWARDED THE RADIO NEWS LABORATORIES CERTIFICATE OF MERIT NO. 2374.

**TUBE TESTER**

The "Yankee" tube tester and rejuvenator, Model S-550, submitted by the Lundquist Tool & Mfg. Co., 144 Green St., Worcester, Mass., is a very useful instrument for dealers in radio apparatus, and professional set builders. It does not serve to obtain the static and dynamic characteristics of a radio tube; but makes it possible to check

quickly whether a given tube has the efficiency of a tube of the same type accepted as a standard. The device operates from the 110-volt 50-60-cycle supply line, and does not require any batteries for its operation. Two sockets, a UX and a UV type, and three special binding posts adopt this instrument for testing various types of tubes; UX or UV types, tubes with special connections for the heater (Sovereign type) or with special grid connections (screen-grid). An autotransformer with a sliding contact on the secondary secures the necessary filament heating voltage, and a milliammeter in the plate circuit gives the reference readings.

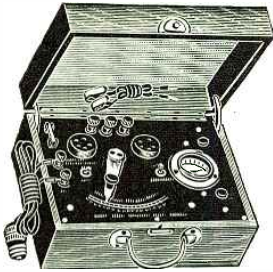

The operation of this instrument consists of applying a low-voltage raw A.C. to the heater while 110 volts raw A.C. is applied to the plate; the grid is either opened or connected to one end of the low-voltage section of the autotransformer. The principle of this instrument is the fact that tubes of the same type and the same efficiency will give identical respective readings on the plate milliammeter, whether the grid circuits is open or closed.

Rejuvenation of a "weak" tube is effected by applying for a short while to the filament an excessive voltage, approximately three times normal, while a special switch keeps the plate circuit open. This operation gives satisfactory results only with tubes having thoriated-tungsten filaments.

AWARDED THE RADIO NEWS LABORATORIES CERTIFICATE OF MERIT NO. 2375.

**R.F. CHOKE**

The R.F. choke shown, submitted by the Leslie F. Muter Company, 76th St. and Greenwood Ave., Chicago, Ill., is a multi-layer self-supporting coil, made of D.C.C. wire. The winding is approximately 1 inch long and has an exterior diameter of 1 3/8 inches, with a 1/4-inch central opening. Its resistance value is approximately 142 ohms, and it has an inductance value of 51 millihenries (measured at 1,000 cycles). The distributed capacity is

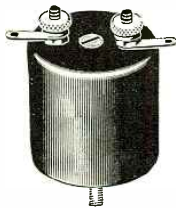

extremely low (below 2 mmf.). This coil is housed in a black molded bakelite housing 1 3/8 inches in diameter, provided with binding posts. It may be mounted on the panel or sub-panel with one screw.

AWARDED THE RADIO NEWS LABORATORIES CERTIFICATE OF MERIT NO. 2376.

**Letters from Constructors**

(Continued from page 157)

by Mr. Nichols in the May issue, and included some improvements which make for easier adjustment.

I could get only 3/16-inch square brass locally and, as you see, I slipped the brass between the bridge and the iron plate that covers the field coil; fastening the iron plate to the brass strips by means of four flat-head bolts. Then I assembled the entire outfit except the field magnet; you can easily assemble the movable coil in the hole in the iron plate, and then fasten the field coil in place afterwards. It worked without loosening a screw afterward. I used the bellows board of an old organ for my baffle and some of the fine bellows leather ("zephyr skin") used in player pianos for the support of the "free edge." I'll be glad to furnish further details if desired.

BYRON E. DICKENSHEETS,  
Otterbein Home, Lebanon, Ohio.

**Like a Magic Hand  
Grasping the Clear, Powerful  
GROUND WAVES**

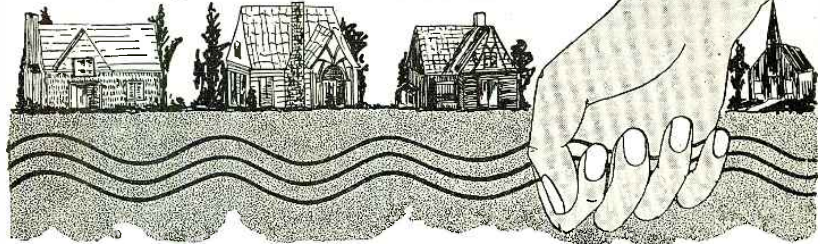

Like a magic hand reaching below the earth's surface, VIAGROUND brings to your radio the smooth impulses of ground waves. This means greater freedom from static even in mid-summer, and the most distant stations heard with clarity and volume.

**VIAGROUND**

**The Invention of a Great  
Radio Scientist**

VIAGROUND is one of the achievements of Earl Hanson, inventor of the Piloting Cable System used in the harbors of New York, Southampton, Cherbourg and Brest for the guidance of ocean liners; also inventor of the Radio Cable System for guiding air planes and of the Vactuphone and a pioneer in Television. The Electrola and Panatropo also are based in all major respects on Hanson patents and applications. Viaground is installed underground

(the work of a few minutes) and thus instead of tapping a vast reservoir of static as you do with an aerial, you get intensive, practically unbroken radio wave energy. It actually puts you "in tune with Mother Earth."

**DEALERS**  
We have an interesting proposition for you. Write for information.

With our highly efficient manufacturing facilities we can produce VIAGROUND to sell at a price which is no more than the cost of installing a roof aerial—and you can buy it on 30-Days Trial. Test it on your own set.

Ask your Dealer or send for Circular

**GENERAL ANTENNA CO.**  
4508-10 Drexel Blvd. Chicago

**Radio's Finest Book of Hookups**

WHAT more could you ask?—150 of the very finest, selected hookups most popular today. Each one completely explained and fully illustrated so that a complete receiver can be constructed from the information. No out-of-date hookups—all the finest and best in common

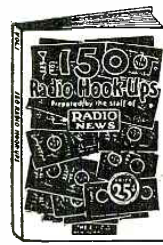

use today. 64 pages, illustrated. Large size, 6 x 9 in. Don't miss this opportunity—All Radio and news dealers have fresh copies Now. If there is no dealer near you write us direct, enclosing 25c.

**25c**

THE COPY

If your dealer cannot supply you, write direct

**THE CONRAD CO., INC., 230 Fifth Ave., New York City**

## Protects A-C Tubes— Improves reception!

Excessive voltage burns out A-C tubes, filters and step-down transformers. They are built to operate on 110 volts. In many cities the normal line voltage is from 112 to 118 volts. In most cities, too, the voltage varies with the time of the day. These "surges" burn out tubes, and harm sets.

### Wirt A-C Voltage Regulator No. 211

prevents these troubles. It will protect your set and tubes. It eliminates A-C "hum." At the same time, it enhances the tonal quality of your set and gives truer reproduction of music and the speaking voice.

Costs only \$2.25. If your dealer cannot supply you, send direct. Get yours today!

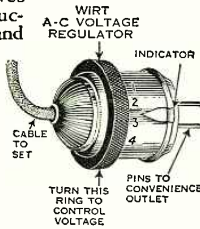

**WIRT COMPANY**  
5221 Greene St., Philadelphia, Pa.  
Makers of "Dim-a-lite" and "Dim-a-lamp"



### RADIO CONVENIENCE OUTLETS

Know the greater convenience of a home wired for radio. Every connection to loud speaker, aerial and ground, A. C. outlet and batteries taken care of in a neat, efficient way. Fit any standard switch box.



- No. 135—For Loud Speaker.....\$1.00
- 137—For Battery Connections. 2.50
- 136—For Aerial and Ground... 1.00
- 138—For A. C. Outlet..... 1.00

With Bakelite Plates Rich satin-brown Bakelite plate, with beautiful markings to harmonize, at 25 cents extra. See illustration.

At Your Dealers

**YAXLEY MFG. CO.**  
Dept. N, 9 So. Clinton St.  
Chicago, Ill.

## NEW! LACAULT'S CALIBRATED

### Short Wave Set

Blueprint and Construction data 50c

R. E. LACAULT  
1931 Broadway Suite 405 New York

Headquarters for

## STROBODYNE

and the latest

R-E-L. 9

Quick Shipment—All Parts

Insure your copy reaching you each month. Subscribe to RADIO NEWS—\$2.50 a year. Experimenter Publishing Co., 230 Fifth Ave., N. Y. C.

## On the Short Waves

(Continued from page 162)

degrees north and one hour west of Pacific Time. This territory of 200,000 square miles has not a single broadcast station. The nearest stations of consequence are over 1,000 miles away. From this you will see that DX is the only kind we have and as it is daylight all the summer nights enough is said.

By use of a 10-tube Mercury Superheterodyne in winter we have U. S. A., Hawaii, Australia, Japan and even Europe (over the North Pole) but they are erratic visitors. Imagine our delight when we find a new radio world developing before our ears and in the full glare of the sub-arctic sunlight. This is what has happened when the short-wave telephones got below 35 meters. No need to sit up nights now nor even to strain your ears as I can produce deafening reception on a loud-speaker network. Current events in London and New York are known here almost before they happen.

I have been listening in for more than two years and find the following stations to have arrived here with loud-speaker volume regularly: 2XAF and 2XAD wonderful; 3SW, London, very good; PCJJ good at times. 3XM (WJZ) just found, but good; CF, Canadian Marconi, very good last year; KDKA generally mushy; 2XAL heard once so that with much strain could get announcement, very weak.

This is all of them and one wonders why, after looking at the lists published. I venture to guess that it is sheer power radiated that counts. I have an aerial wire 1,000 feet long and use a five-tube receiver, largely audio end, which leaves little to be desired in the way of reception. I also use the Mercury Super with plug-in coils for short waves.

In closing I will say that above 35 meters the stations act same as on the broadcast band, and with less than 20 kw. they don't enter the picture. Here's hoping to burn out the detector tube on 2XAL when it gets to a hundred K.W.

A. K. SCHELLINGER,  
Wernecke, Yukon Territory, Canada.

### WISHES CORRESPONDENTS

Editor, RADIO NEWS:

I am writing to ask you if you would be good enough to ask some of the readers on your side of the Atlantic who are interested in European transmissions to get into communication with me, as I should like to exchange ideas. I am thinking of building the short-wave receiver described in the April issue, but do not know what kind of tube to use; as American tubes are not easy to get in this country. I think yours the best radio paper published, and wish it luck in its new policy.

JOSEPH H. GOUGH,  
47, Church Street, Southwell, Notts., England.

Editor, RADIO NEWS:

I am a short-wave enthusiast, and would like to exchange letters with experimenters all over the world, especially with French amateurs.

HOWARD BAILEY, 9AKR,  
Route 2, Senath, Missouri.

Neil C. Gilchrist, Camaru, New Zealand, has had excellent results. He writes as follows: "I made up the short-wave receiver described on page 348 of the October, 1927 issue of RADIO NEWS and, among others, have heard the following stations: PCJJ; PCTT; PCMM; PCPP; PCRR; PCUU; GDGV; JAN; LGN; ANH; 2XAD; GBH; HVA; FSI; and HJG."

L. O. Lumley of London, England, has had considerable success in receiving American short-wave broadcast stations, according to his letter, which lists 2XAL, (Radio News); WLW; KDKA; 2XG; 2XAD; 2XAF and KDKA. "Stations 2XAF and KDKA are received with good volume at about 11 P. M. while 2XAD is received well at 7 P. M. but fades away about 9 P. M. A four-tube set is used here."

The best reception of KDKA's short wave is reported on the Pacific Coast. In the territory between Pittsburgh and the western states however, the short-wave signals are scarcely audible.

While maintaining transmission on 27, 42.95 and 62.5 meters, KDKA has abandoned the wavelength of 2.5 meters, as it is considered too low to be of any practical value at this time. All transmitters used at this station are crystal-controlled.

The schedule announced for this year states that the short-wave transmitters will be used nightly (except Sundays) between 8 and 10 o'clock on 27 and 62.5 meters and, occasionally, on 42.95 meters; however, these transmissions are of an experimental nature and this schedule is subject to frequent changes.

# ALL ABOUT TELEVISION

INCLUDING  
EXPERIMENTS  
BY  
H. Winfield Secor & Joseph H. Kraus

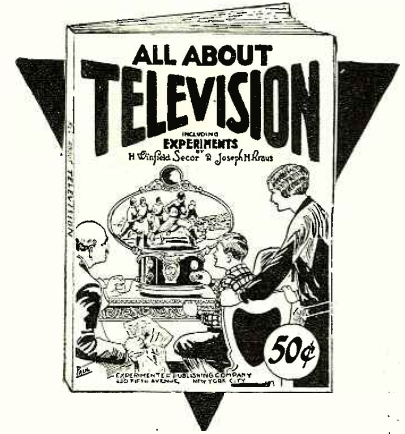

This book is one of the most complete treatises ever written on this all-grossing subject. Its entire contents was prepared by the editor of SCIENCE AND INVENTION, Mr. H. W. Secor and the Field editor, Mr. Jos. Kraus. Many months of tireless research were spent in collecting the vast amount of information that it contains. Every known step in the development of Television has been fully and understandingly covered. All methods used to transmit and reproduce moving scenes are fully explained. But, TELEVISION gives you more than this. There are complete instructions for building an

### EXPERIMENTAL TELEVISION OUTFIT

A modern method for constructing an experimental Television outfit is explained in detail in this remarkable discourse. With this set the "fan" can carry on his own experiments just as he did with radio a few short years ago. Do not fail to get a copy of this remarkable book.

Over 116 pages—Fully illustrated—Complete instructions for building an experimental set

THE **50c** COPY

AT ALL NEWSSTANDS OR  
WRITE DIRECT TO

Experimenter Publishing Co., Inc.  
230 Fifth Ave., New York, N. Y.

EXPERIMENTER PUBLISHING CO., Inc.  
230 Fifth Ave., New York, N. Y.

Gentlemen: Kindly send me a copy of TELEVISION. Enclosed find 50c.

Name.....

Address.....

City.....State.....

# I Want to Know

(Continued from page 161)

(A.) There are several points which must be considered when discussing the subject of selectivity. Considering an oscillatory circuit, in which we assume that the resistance remains comparatively constant over its complete tuning band, it would probably be better to use a large inductance and small tuning condenser; since this type of circuit gives a higher radio-frequency voltage than one employing a small tuning coil and large condenser. This fact can be proved both mathematically and by laboratory tests with various type of coils.

However, in most oscillatory circuits, the resistance does not remain constant, but varies considerably at different points of the band. The resistance of the coil is usually much higher than the resistance of the condenser, and the resistance of the condenser remains almost constant except at the low end of the capacity scale. From this standpoint, it would be better to employ an oscillatory circuit with a small coil and large tuning condenser; since a circuit is much sharper when the resistance is low than when it is high.

**Station**  
**WRNY**  
**NEW YORK**  
326 METERS — 920 KILOCYCLES  
and 2XAL, 30.91 METERS

*is owned and operated by the  
publishers of this magazine  
Our Editors will talk to you  
several times every week—  
see your Newspaper  
for details*

**TUNE IN ON  
WRNY**

In general practice, however, there is a nominal value in which both the resistance and voltage are considered. In this way, by balancing the values of resistance and voltage in the circuit, a value will be found in which neither the voltage nor resistance is at the best point, but the complete oscillatory circuit supplies best results. Of course, this involves a different condenser value for each type of coil considered; and for this reason, no particular condenser can be recommended to give the best selectivity.

### BROWNING-DRAKE RECEIVER WITH SCREEN-GRID TUBE

(2294) Mr. G. A. Deering, Providence, R. I. writes:

(Q.) "I am enclosing a diagram of my two-tube Browning-Drake tuning unit, in which I would like to use a screen-grid tube. I believe that the use of one of these tubes in the radio-frequency stage will increase the amplification and improve the results that I am obtaining. Can you give me the necessary details for making this change?"

(A.) We are publishing the diagram of the original receiver and the new diagram showing a 222-type tube used in the radio-frequency amplifier circuit. (Figs. Q2294A and B.) As you will notice in Fig. 2294B, the original primary of the detector coupling coil has been left out of the circuit. It will be desirable to shield both the radio-frequency stage and the detector, in order to obtain the best results from the screen-grid tube. The radio-frequency stage is capacity-coupled to the detector by a 1/2-mf. condenser between the radio-frequency tube plate and the coil of the detector coupler. A radio-frequency choke coil is also placed in the "B+" lead to keep the radio-frequency current in the correct channel. It may also be necessary to connect a 15-mmf. condenser across the tuning condenser.

The filament current of the screen-grid tube is

controlled by a 10- to 15-ohm fixed resistor and a 30-ohm rheostat. Both of the tubes are connected to the "A" battery through a filament ballast resistor of 1/4-ampere capacity.

### Adjusting the Receiver

When these changes have been made, the set may be tuned in the usual manner. The screen-grid tube requires no neutralization, so the original neutralizing condenser may be dispensed with.

The use of the screen-grid tube should increase the radio-frequency amplification to a great extent; we believe that very good results will be obtained when using it in place of the 201A. The voltage on the screen-grid is rather critical and must be very carefully adjusted, and the shields must be made very carefully in order to have the tube operating correctly. The parts should be laid out approximately in the same positions that they occupy in the original set, but with the addition of the extra by-pass condensers, etc. The control-grid lead should be kept as short as possible and preferably should be placed in a length of copper or brass tubing. The tubing should be grounded to the shield.

A description of a new Browning-Drake tuning unit designed especially for the screen-grid tube will be found in the "What's New in Radio" department of this number of RADIO NEWS.

### A.C. RECEIVER DIAGRAM

(2295) Mr. G. C. Edwards, Tarrytown, New York, writes:

(Q.) "I have one of the All-American 6-tube A.C. receivers. The receiver is working perfectly satisfactory, but I would like to know just what type of circuit is employed in this set. Can you publish the diagram for me? This should be of interest to a number of radio fans who own these sets.

(A.) We are showing the requested diagram as Fig. Q2295. As you will notice, a system similar to the Rice method of balancing is employed. In this system, the voltages fed back through the internal capacity of the tube, from the plate to the grid, enter the secondary winding and pass down through part of the secondary coil to the filament. The voltages fed through the balancing condenser enter the winding at the opposite end and pass up through the winding to the filament. The voltages in these two circuits are made equal by adjusting the balancing condenser. Since the two halves of the secondary winding are in opposition, the two voltages balance each other and any tendency to oscillation is suppressed.

A number of by-pass condensers are employed to pass the radio-frequency currents and to obtain the zero-potential points in the filament circuits of the A.C. tubes. The aerial is coupled to the first tube through a variable condenser, which controls the selectivity of the receiver to some extent.

### AERIAL WITH LOOP SET

(2296) Mr. R. N. Langley, Lakeland, Fla., writes:

(Q.) "I have been using a portable receiver which operates from a built-in loop aerial, and I believe I could get better results with an outside aerial. I do not wish to make any changes in the receiver, however, and since the loop aerial is built in I would not like to remove it. Is there any way in which an aerial can be used with my set?"

(A.) There are several methods which could be used for connecting an aerial and ground to a portable set operated from a loop aerial. Some receivers are so constructed that either a loop or outside aerial can be used; the loop being cut out

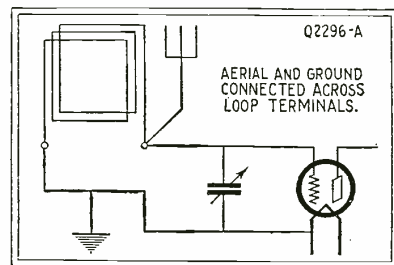

The loop shown above corresponds to the ordinary tuned aerial-coupler coil. The characteristics of the antenna combine those of loop and aerial.

while the aerial system is being used. However, there is another way to use an outside aerial with a loop receiver. The loop can be used as the secondary or tuning inductance and the aerial and ground connected to the two ends of it. This method is shown in Fig. Q2296A.

# Ach eve SUCCESS in Radio

New course gives finest instruction obtainable

You Can Learn at Home!



R.L. DUNCAN, Director, Radio Institute of America and author of several volumes in radio.

Good pay from the start, rapid advancement, and phenomenal success—a life profession of fascinating brain-work—that is what Radio holds for the man who knows his subject thoroughly. Since 1909 Radio Institute of America has trained thousands to become successful in the many branches of Radio. Are you going to plod along at a thirty-five dollar a week job when REAL MONEY is waiting for you in radio?

### New Course Finest Ever

Prominent radio men have enthusiastically greeted RIA's new course as the finest and most complete radio instruction offered today. It starts with the very fundamentals and takes you through every phase of radio—right through television, photoradiograms, and airplane radio equipment.

The instruction is the work of radio experts and its clearness and simplicity are such that you can master every point with ease. You take examinations and your papers are corrected by men with years of radio experience. All your questions are answered and you are in contact with the Institute at all times.

### A-1 Equipment

Radio Institute of America's students must have the best. So we provide, without charge, all the first-quality material you need (except tubes) to make twelve different radio circuits—as well as the Peerless Signagraph and key and buzzer set for code instruction.

### RIA Sponsored by RCA, G-E, and Westinghouse

You get all the benefits of instruction conducted by RCA and sponsored by RCA's associates, G-E and Westinghouse. Our employment department is at the service of graduates.

### Study at Home!

Moreover you can STUDY AT HOME—when you please and as long as you please. This new booklet describing the course is just off the press. If you want to learn more about the well-paying positions in this fascinating profession send the coupon now for your copy.



RADIO INSTITUTE OF AMERICA  
Dept. A-8 326 Broadway, New York City

RADIO INSTITUTE OF AMERICA, Dept. A-8  
326 Broadway, New York City

Dear Mr. Duncan:  
Please send me your new catalog. I want to know more about your new radio course.

Name.....  
Address.....

# OPPORTUNITY AD-LETS

Follow these advertisements every month. Reliable advertisers from all over the country offer their most attractive specials in these columns.

Classified advertising rate twenty-two cents a word for each insertion. Ten per cent discount for 6 issues, 20 per cent discount for 12 issues. Names and addresses must be included at the above rate. Cash should accompany all classified advertisements unless placed by an accredited advertising agency. No advertisements for less than 10 words accepted.

Objectionable or misleading advertisements not accepted. Advertisements for the October issue must reach us not later than August 1st.

**CIRCULATION LARGER THAN THAT OF ANY OTHER RADIO PUBLICATION**

EXPERIMENTER PUBLISHING CO., INC., 230 Fifth Avenue, New York, N. Y.

## Agents Wanted

**Big Money and fast sales.** Every owner buys gold initials for his auto. You charge \$1.50; make \$1.35. Ten orders daily easy. Write for particulars and free samples. American Monogram Co., Dept. 133, East Orange, N. J.

**Agents—We start you in business and help you succeed.** No capital or experience needed. Spare or full time. You can earn \$50-\$100 weekly. Write Madison Products, 560 Broadway, New York.

**Guaranteed Genuine Gold Leaf Letters** anyone can put on store windows. Large profits, enormous demand. Free samples. Metallic Letter Co., 422 N. Clark, Chicago.

**Sell subscriptions to magazines known the world over.** Steady monthly income with absolutely no investment required. Hundreds of selling arguments every month. Start now. Full information sent free, no obligation. Agency Division, Experimenter Publishing Co., 230 Fifth Avenue, New York.

**Get Our Free Outfit Offer.** Wonderful line 350 fast-selling household necessities. Every home buys; \$15 a day sure; car furnished. American Products Company, 1906 Monmouth, Cincinnati, Ohio.

**Sell Bright, Beautiful Embossed Signs** to Merchants Everywhere. Sample and particulars free. Synogra, 235 Douglas Bldg., Los Angeles, California.

**Tired of working for other people?** Without experience, training or capital I'll show you how you can become financially independent. Easy, pleasant work. \$100 profit every week. Free automobile. Write today for particulars. Albert Mills, Mgr., 1507 Monmouth, Cincinnati, Ohio.

## Books

**Books, Magazines, Art Publications** in French, Spanish English. Photo novelties, samples, lists, etc., 20 cents stamps. Villaverde Co., Dept. 211, Box 1329, Havana, Cuba.

## Business Opportunities

**Inventions Commercialized.** Patented or Unpatented. Write Adam Fisher Mfg. Co., 278 Enright, St. Louis, Mo.

**Free Book.** Start Little Mail Order business. Hadwil, 5A-74 Cortland Street, N. Y.

**67 Ways to Increase Income.** 96-page book "Spare-time Money Handbook" contains 67 practical and complete plans to operate sparetime business. For everyone who wants more money. Price only 50c. Conrad Company, Inc., 230 Fifth Avenue, New York.

## Chemistry

**Learn Chemistry at Home.** Dr. T. O'Connor Sloane, noted educator and scientific authority, will teach you. Our home study correspondence course fits you to take a position as chemist. See our full-page ad on page 169 of this issue. Chemical Institute of New York, 16 E. 30th Street, New York City.

## Correspondence Courses

**Used correspondence school courses** sold on repurchase basis. Also rented and exchanged. Money-back guarantee. Catalog free. (Courses bought). Lee Mountain, Pisgah, Alabama.

## Distributors Wanted

**New—A Loudspeaker Chandelier.** Radio News Merit No. 2354. Want National or Local Distributors. Standard Compo Works, 409 12th St., Milwaukee, Wis.

## Electricity

**Electric Fun!** Seventy stunts, 110 volts, \$1. Cooperco, Campbell, Calif.

## For Inventors

**Inventions Commercialized.** Patented or Unpatented. Write Adam Fisher Mfg. Co., 278 Enright, St. Louis, Mo.

## Help Wanted

**National Publisher,** needs agents, boys and shops to help sell great national magazines. No investment required. Big profits, sparetime work very successful. Write Agency Division, Experimenter Publishing Co., 230 Fifth Avenue, New York.

## Instruction

**Learn Chemistry at Home.** Dr. T. O'Connor Sloane, noted educator and scientific authority, will teach you. Our home study correspondence course fits you to take a position as chemist. See our full-page ad on page 169 of this issue. Chemical Institute of New York, 16 E. 30th Street, New York City.

**Men—Qualify** for railway postal clerk, internal revenue, mail carrier and outdoor positions; steady work; particulars free. Write Mokane Inst., Dept. B-32, Denver, Colo.

# Read!

## Opportunity Ad-Lets

Who knows but that the opportunity of your lifetime may be hidden in one of them. Read them each month—they can easily be turned to earning dollars and cents for you.

## Miscellaneous

**Inventions Commercialized.** Patented or Unpatented. Write Adam Fisher Mfg. Co., 278 Enright, St. Louis, Mo.

**Save Money at Home.** You can build many home necessities yourself, such as furniture, kitchen utensils, decorative material, etc., thus saving many dollars. All constructional information on hundreds of things given in 116-page book "How to Make It." Price 50c. Experimenter Publishing Co., Inc., 230 Fifth Avenue, New York.

**Forms to Cast Lead Soldiers, Indians, Marines, Trappers, Animals,** 151 kinds. Send 10c for illustrated Catalogue. H. C. Schiercke, 1034 72nd St., Brooklyn, N. Y.

**Capital Bulletin M,** containing information of priceless value to responsible parties, yours upon request. Free analysis and advice cheerfully given. Moderate rates. Morris, Financing Specialist, 3608 Warren St., Philadelphia.

## Musical Instruments

**Cornetists—Trombonists—Saxophonists—Clarinetists.** Send for "Free Pointers." Mention instrument. Virtuoso School, Buffalo, 70, N. Y.

## Patent Attorneys

**Patents—Send for form "Evidence of Conception"** to be signed and witnessed. Form, fee schedule, information free. Lancaster and Allwine, Registered Patent Attorneys in United States and Canada, 269 Outray Bldg., Washington, D. C.

**Patents—Send drawing or model of your invention** for examination and instructions. Advice and booklet free. Highest references. Best results. Promptness assured. Watson C. Coleman, Patent Lawyer, 724 9th Street, N.W., Washington, D. C.

**Patent Sense—Valuable book free.** See Lacey's ad, page 180. Lacey & Lacey, 631 F. St., Washington, D. C. Established 1869.

**Patents—Time counts** in applying for patents. Don't risk delay in protecting your ideas. Send sketch of model for instructions or write for free book, "How to Obtain a Patent" and "Record of Invention" form. No charge for information on how to proceed. Communications strictly confidential. Prompt, careful, efficient service. Clarence A. O'Brien, Registered Patent Attorney, 309 Security Bank Building (directly across street from Patent Office), Washington, D. C.

**Patents procured** at reasonable rates with time to pay. Sales negotiated. Staff of registered attorneys and engineers. A complete service for inventors. Write for particulars. Inventors Service Bureau, Box 1648, Washington, D. C.

## Patents

**Inventions Commercialized.** Patented or unpatented. Write Adam Fisher Mfg. Co., 278 Enright, St. Louis, Mo.

## Printing, Engraving and Multigraphing

**Multigraphing,** two dollars thousand. Miscellaneous Printing. Mayer Rey Corporation, Monmouth, Illinois.

**200 Letterheads and 100 Envelopes,** \$1.10, postpaid. Oberman Company, Box 1268, Chicago.

## Radio

**Buy Your B. Power Devices Direct From Factory.** Send for particulars. D. L. & G. Mfg. Co., 2941 W. Lake, Dept. 9, Chicago.

**Write about our efficient power devices.** KIMLEY ELECTRIC CO., 441 E. Ferry, Buffalo, N. Y.

## Scenery to Rent

**World's Most Beautiful settings** for operas, plays, minstrels. Amelia Grain, Philadelphia.

## Song Poem Writers

**Song Poem Writers address,** Hibbeler, D7X, 2104 N. Keystone Ave., Chicago.

## Telegraphy

**Telegraphy—Both Morse and Wireless** taught thoroughly. Big salaries. Wonderful opportunities. Expenses low, chance to earn part. School established fifty years. Catalog free. Dodge's Institute, Cour St., Valparaiso, Ind.

## Wanted to Buy

**Full Value Paid for Old Gold, Jewelry, Watches, Diamonds, crowns, bridges, dental gold, silver, platinum, gold or silver ore; magneto points, old false teeth.** Packages returned if our offer is not satisfactory. United States Smelting Works (The Old Reliable), 39 So. State St., Dept. 18, Chicago, Ill.



As you will notice, the aerial and ground connections are simply made to the two ends of the loop aerial. When making these connections, the end of the loop which is connected to the filament circuit of the receiver should be connected to the ground and the grid end to the aerial. This method will increase the signal strength, but will also reduce to some extent the selectivity of the receiver. The selectivity can be increased by making a tap on the loop aerial, two or three turns from the ground end, and connecting the aerial to this tap.

Another method is to wind two or three additional turns of wire on the loop frame, placing them near that end of the loop which connects to the filament circuit of the receiver. One end of

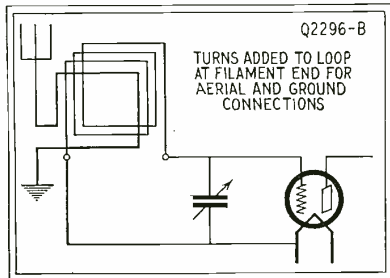

The loop used in this fashion becomes the secondary of an aerial-coupling R.F. transformer. The coupling may be made variable.

this new coil connects to the aerial and the other end to the ground. This method is shown in Fig. Q2296B.

It is possible also to arrange a small loop inside of the regular loop used in the set, in such a manner that it can be rotated within the larger one. This allows a variable coupling, so that the correct device of selectivity can be obtained. An increase of signal strength can be obtained also by simply connecting the filament end of the loop in your set to ground. No aerial is used with this connection.

All of the methods described above will increase the sensitivity and volume of a loop set at the expense of the selectivity. By careful manipulation, however, a system can be found which supplies sufficient selectivity with an increase in signal strength.

**A.C. RECEIVER DATA**

(2297) Mr. C. Lund of Seattle, Wash., writes: (Q.) "I have several questions which I would like to have answered in the 'I Want to Know' columns of RADIO NEWS.

"Kindly explain why the A.C. sets do not require rheostats in the filament circuits, to facilitate receiving close and distant stations?"

"Which filament circuit in an A.C. set is the best to make connections with a pilot or dial light?"

(A. 1.) The reason why rheostats are not commonly used in alternating-current receivers is because the filaments in these tubes are not sensitive to slight changes in temperature. In other words, the electronic emission of the filament remains about the same although the filament temperature is not constant. In the heated-cathode tubes, this is due to the fact that the electrons are emitted by a small cylinder which is indirectly heated by the filament. Naturally, when the cylinder becomes hot, a slight change in the temperature of the filament will not immediately change the temperature of the cylinder. In the direct-filament A.C. tubes, a very low voltage and a high current are employed on the filament. This also tends to keep a steady emission, even though the filament voltage is changed.

However, the life of alternating-current tubes is reduced to a considerable extent when the filament voltage is increased over the rated value. For this reason, it is desirable to place a rheostat in each filament circuit so that the applied voltage can be controlled even though the line voltage changes. In this way, by operating the filaments of the tubes at a value slightly lower than that specified, the life of the tubes will be increased and the operation will not be affected.

(A. 2.) The pilot lights employed in an A.C. set can be connected to any of the filament circuits with equal results. However, since the bulbs supplied with these lights are usually designed for a five-volt supply, it is usually advisable to connect the dial lights to the power tube; since this tube is usually operated from a five-volt filament supply. Of course, it is an easy matter to change the bulb to one which will operate from the lower voltages usually supplied to A.C. tubes; so that no difficulty will be encountered in this matter.

**"In No Way Connected"**

Editor, RADIO NEWS:

We wish to call your attention to the article published in the June issue of your magazine, entitled "Shoppers Should Beware of the Radio 'Gyp,'" page 1315. This article refers to a Parker Radio Store.

Although we know that the article refers to a Parker Radio Store of Philadelphia, many of our customers have connected our store with that of the Philadelphia one. Our customers even mentioned that the picture of the store, as printed on page 1315, is that of our own. (Wrong!—Error.) It is necessary to read through the article before the reader knows that it is the Parker Radio Store of Philadelphia.

Many of our customers are readers of your magazine; in fact, we have it for sale. When they asked us about this article, we told them that we have no connection with any other store. How they took our explanation, we don't know. However, we feel certain that if they read it in your magazine, it would remove all wrong impressions which your June article has made.

In justice to ourselves, and your desire to disseminate the proper information to the radio public, may we ask that you insert in your next issue a line or two to the effect that we are in no way connected with any other concern of similar or any other name?

We will appreciate anything you will do in compliance with our request.

PARKER RADIO STORES, INC.

406 Lexington Ave., New York City.

(In justice to the Parker Radio Stores, Inc., of 406 Lexington Avenue, New York City, we are glad to print its statement that it is in no way connected with the Parker Radio Store of Philadelphia, whose policy was the subject of an article in our June number.—Error.)

**Radio Study in Denmark**

Editor, RADIO NEWS:

I am a "R. N." reader and a pupil in a Danish cathedral school, where we have a radio club (established 1926) with plenty of members. We have a meeting every Thursday with a lecture, experiments, and so forth. Before it was started, we had a four-tube set which wasn't good. Then we built a new one with a "B" power unit. Before summer, we will build a short-wave transmitter. I have a self-made three-tube all-electric set, with stick coils for 200-600 and 600-2,000 meters and plug-in coils for bands from 10 to 200 meters.

In Denmark we have a very good broadcast station, Kalundborg, on 1,150 meters and 7,500 watts, and several others. Kalundborg has been heard on the loud speaker with a five-tube set at Godhavn in Greenland. The American stations are heard very well in Denmark, and I should like to know if Kalundborg can be heard in America. I enclose a local program.

MOGENS BANG,  
Saxkjöbing, Denmark.

(Unfortunately, the time difference works against American listeners, especially during the summer, and few American sets have the plug-in coils to reach the European long-wave band. There would be a greater chance, therefore, of our listeners hearing the same program from Copenhagen (Köbenhavn) on 337 meters from a lower-power transmitter.—Error.)

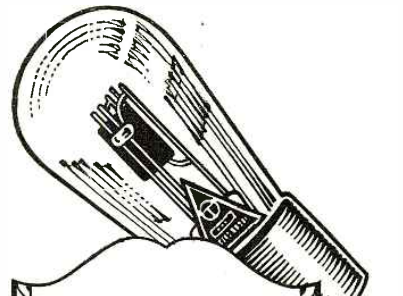

For velvet-like tone and performance, use Televocal Quality Tubes. All standard types. Ask for them at your dealers.

**Televocal Corporation**

Televocal Building

Dept. A-1

588 12th Street

West New York, N. J.

**Televocal Quality Tubes**

**Self-Adjusting!**

For best performance your tubes require a variable filament control to supply the definite current they need, despite "A" battery variations. AMPERITE is the only self-adjusting and automatic filament tube control that does this. Takes the "guess," inconvenience and unsightliness out of panel rheostats. Simplifies wiring, panel design, and tuning. Prolongs tube life. Order by name. Accept nothing else. Price \$1.10 mounted (in U. S. A.) For sale by all dealers. Write for FREE "AMPERITE BOOK" of season's best circuits and latest construction data. Address Dept. R. N.—53

**RADIALL COMPANY**  
50 Franklin St., New York

**AMPERITE**  
The "SELF-ADJUSTING" Rheostat

**FREE! 30 DAY TRIAL!**

**Powerful 6-7 or 8 Tube Guaranteed RADIO**

Radio's most amazing bargain, direct from big, reliable maker (8th successful year). All Electric or Battery sets. Consoles or table cabinets. Don't buy unless 30 days trial proves Miraco unbeatable at 2 to 4 times the price for selectivity, distance, volume and rich, Cathedral tone. Turn 1 dial for all stations. Complete or assembled, fully guaranteed set!

**Free literature, users' testimony and BIG SPECIAL OFFER!**

**MIDWEST RADIO CORPORATION**  
Pioneer Builders of Sets  
404 Miraco Bldg., Cincinnati, O.

**RETAIL \$36.75 TO \$69.75**

# THESE

# 2

# MAGAZINES

# for

# THE PRICE

# OF

# 1

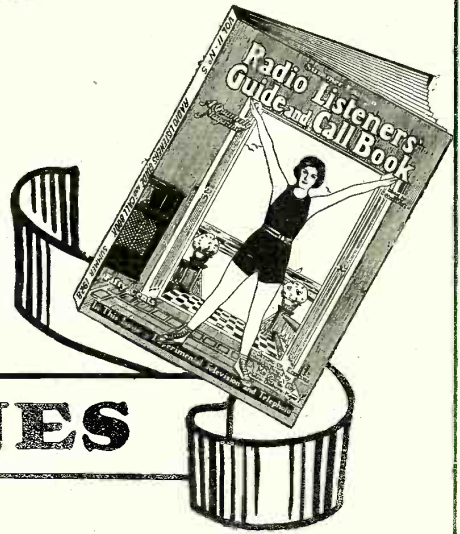

A year's subscription to these two popular magazines for the price of Radio News—alone. If you were to buy Radio News and Radio Listeners' Guide and Call Book individually for one year they would cost you \$5.00. By our special combination yearly subscription rate you can get both of these foremost radio periodicals at the tremendous bargain price of \$3.00. In order to keep up with the latest developments of Radio, to know the newest sets and how to build them, to find every radio broadcasting station you must read these leading periodicals of radio.

The RADIO LISTENERS' GUIDE AND CALL BOOK is the foremost quarterly magazine in the field. A special feature of this remarkable magazine is the up-to-the-minute log of every station in this country,

Canada and in Europe. This list of call letters is carefully checked and corrected in each quarterly edition.

RADIO NEWS is read each month by more radio enthusiasts than any other publication in the field. It contains the latest developments and the most modern circuits of the radio world. Honest, unbiased opinions on every subject of interest—this is what RADIO NEWS gives you.

Write today—insure your receiving each issue of RADIO LISTENERS' GUIDE and CALL BOOK and RADIO NEWS. Take advantage of this special subscription offer—Two magazines for the price of one.

Special Combination Yearly Subscription Rate

## \$3.00

For the Radio Listeners' Guide and Call Book and Radio News

### EXPERIMENTER PUBLISHING COMPANY

230 5th AVE., NEW YORK CITY, N. Y.

EXPERIMENTER PUBLISHING COMPANY  
230 5th AVE., NEW YORK, N. Y.

Gentlemen:—Enclosed find \$3.00 for which please send me the RADIO LISTENERS' GUIDE and CALL BOOK, and RADIO NEWS for one year beginning with the next issue. It is understood there will be no further payments of any kind.

Name .....  
Address .....  
City .....  
State .....

# Don't Let Summer Static Spoil your Radio Fun

Get tones as full and clear in summer as in winter. All you need is the simple but wonderful device, invented by Dr. J. Harris Rogers, eminent radio scientist, which has put the aerial out of date. Can be installed in just a few minutes. Use it with any set.

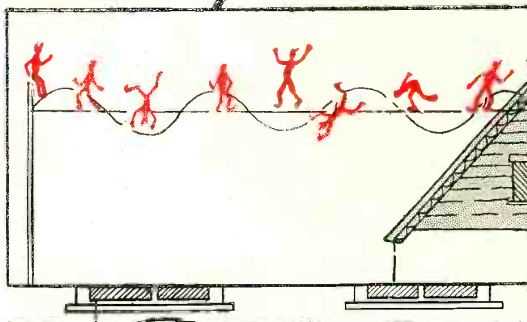

Installed in a  
Few Minutes  
Underground

## Get Distance

Loud and Clear Under All Conditions  
with the Patented, Perfected

# ROGERS Underground ANTENNA

Amazing results obtained. Even in mid-summer when static is worst—when electric storms are raging—and in blizzardy winter weather—which conditions make listening actually impossible with the aerial—this wonderful *underground* antenna delivers DX in full force.

## A Scientist's Invention that Baffles the Weather by Using Ground Waves

You get faulty reception now because you are using aerial waves—the waves that static most easily disturbs. Dr. Rogers' invention utilizes *ground* waves which are less affected by static. That's the reason why the most particular radio fans are discarding their aerials and using the Rogers Patented Underground Antenna. They want service all the time.

And here's another point—*safety*. When you install the Rogers device, you are through with roof climbing to make repairs on an aerial. And you get rid of the outside wire that invites lightning to strike and which would carry the current into the house. No lightning danger when you have a Rogers Underground Antenna—and *always* loud, clear DX.

## FREE TRIAL on Your Own Set

It costs you nothing to find out what Dr. Rogers' invention will do for you. Install it (that takes only a few minutes). Then compare results with those you get from your aerial. Make

the test under trying conditions. Switch from one to the other. Then you will know. If you don't find that the Rogers Underground Antenna is all we claim the test costs you nothing.

**THE UNDERGROUND ANTENNA CO.**  
4207-W Cottage Grove Ave., Chicago

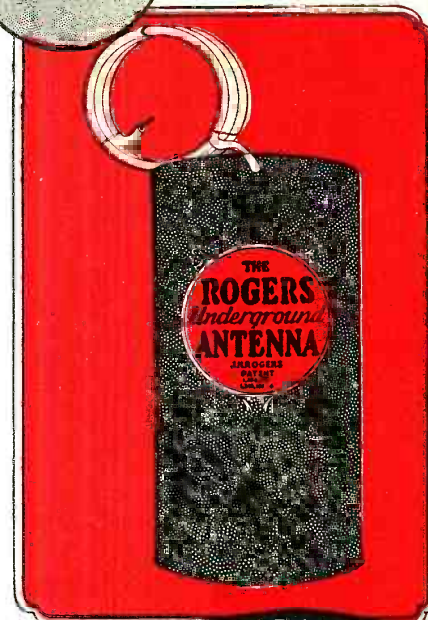

## SEND COUPON

Send the coupon now and get all the facts about our free trial offer. You will find this a very interesting proposition—and there's not a penny's risk. Send today.

**THE UNDERGROUND ANTENNA CO.**  
4207-W Cottage Grove Ave., Chicago

Send me the facts about the Rogers Patented Underground Antenna and particulars of your FREE TRIAL offer and GUARANTEE.

Name.....

Address.....

.....

# Abox



*Slightly higher on  
West Coast*

As the name implies, the Abox A. C. Converter is a device that converts a set using ordinary tubes into an A. C. receiver. The change can be made in a few minutes without tools and without changing set wiring or tubes.

With Abox and any good "B" unit, all the convenience of the electric radio set is yours. In addition, you can use the most sensitive and dependable tubes. Better reception is the result.

The new Abox A. C. Converter consists of a rectifier and a filter. No battery is used. It converts ordinary house lighting current to smooth

direct current. No hum is audible. The Abox works only when the set is in operation and no current is accumulated. The output, large enough for eight-tube sets, does not fluctuate even though the line voltage may vary.

A receptacle for the "B" unit and a master control switch are included in this new model.

For converting Radiola Receivers, the model 44 Abox A. C. Converter is available at \$27.50.

Write today for free descriptive circulars and learn how you can enjoy true electric operation with a minimum investment.

## The ABOX Company

215 N. Michigan Avenue • Chicago

