

RADIO NEWS

REG. U.S. PAT. OFF.

JULY
25 Cents

Over 200
Illustrations



Edited by HUGO GERNSBACK

\$250⁰⁰
FOR THE BEST
TITLE OF
THIS
PICTURE
See Page 20

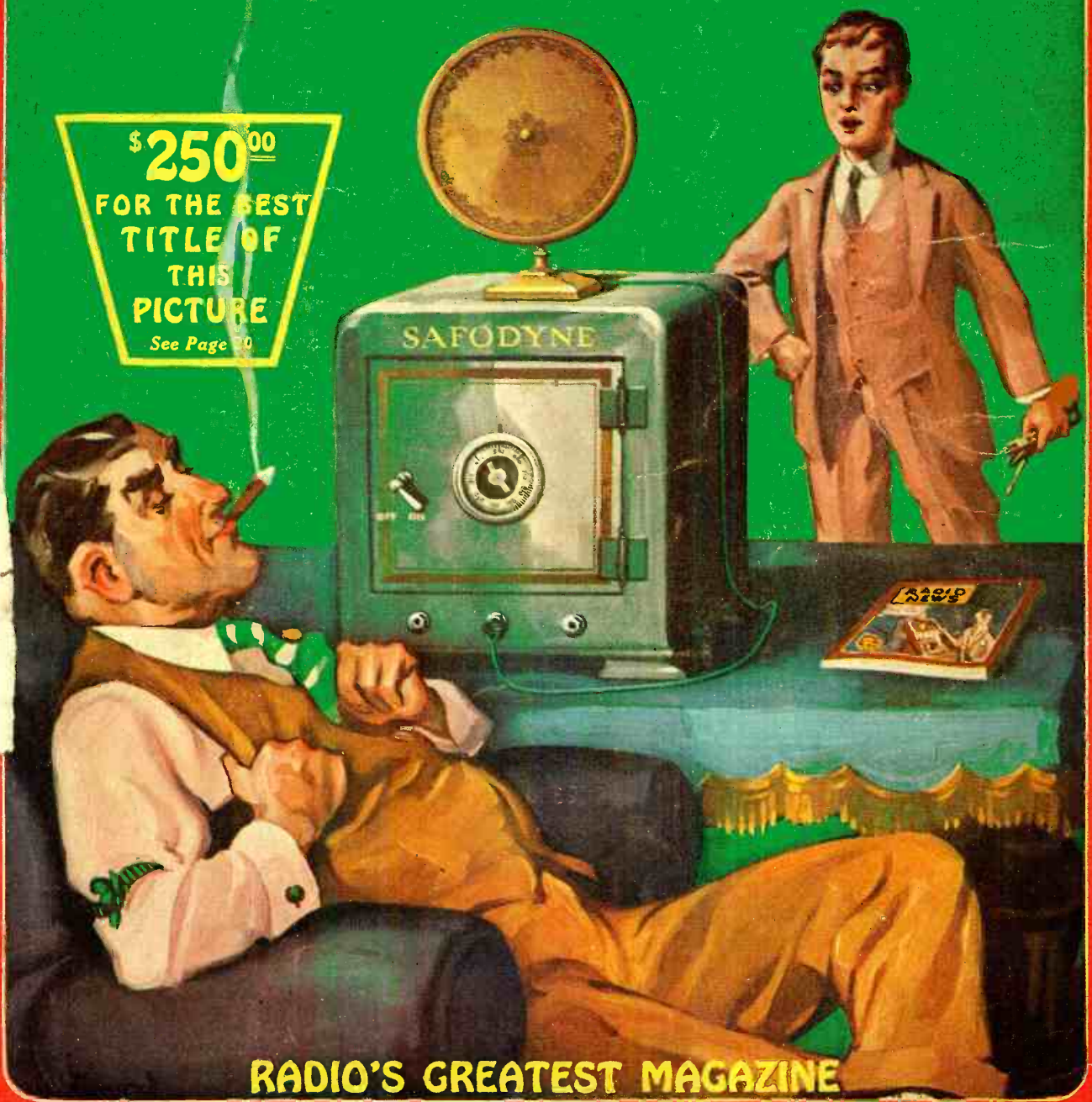

RADIO'S GREATEST MAGAZINE

EXPERIMENTER PUBLISHING COMPANY, NEW YORK, PUBLISHERS OF
RADIO NEWS - SCIENCE & INVENTION - RADIO LISTENERS' GUIDE - AMAZING STORIES - SPARE-TIME MONEY MAKING - RADIO PROGRAM WEEKLY



Cunningham RADIO TUBES

For Resistance and Impedance--- Coupled Audio Frequency Amplification



**CX
340**

**Price
\$2.25**

Operating Characteristics

Amplification factor (mu)	30	
Filament Operating Voltage	5 volts	
Filament Current Consumption	.25 amp.	
Recommended Plate Voltage	135 to 180 volts	
Plate Resistance (at 135 to 180 volts, under operating conditions; not at zero grid bias)	150,000 ohms	
Recommended Plate Resistor (250,000 ohms)	.25 meg.	
Recommended grid resistor (grid leak)	1 to 2 meg.	
Recommended coupling (blocking) condenser	.005 to .05 mfd.	
PLATE AND GRID VOLTAGE VALUES		
"B" volt.	Grid bias volts neg.	Plate Resistor megohms
135	1 to 1.5	.25
180	3	.25
above 180	3 to 4.5	.5 to 1

The secret of success in resistance or impedance-coupled audio frequency amplification lies in the use of properly designed high mu tubes.

The new Cunningham CX 340 high mu tube brings to resistance and impedance-coupled audio frequency amplification efficiency heretofore unattainable with previously existing types of tubes.

A new tube, for a new need, the CX 340 completes, for present needs, the Cunningham line of 16 Special Purpose Tubes. Each type of tube is designed to perform a definite and particular task in radio receivers.

Whenever a new type of tube is needed, Cunningham will produce it, but not before it is practical and has passed the laboratory stage of its development.

Consult your radio dealer. He will tell you the right combination of Cunningham Radio Tubes for your receiver.

CX 340 and fifteen other types in the orange and blue carton.

E. T. CUNNINGHAM, Inc.

New York

Chicago

San Francisco



... See Us ...
at the
CHICAGO
RADIO TRADE SHOW



BOOTH
55

Tower



TOWER MANUFACTURING CO.
BOSTON - - MASSACHUSETTS

RADIO NEWS

Published by EXPERIMENTER PUBLISHING COMPANY, Inc., Publishers of "Radio News," "Science and Invention," "Radio Program Weekly," "Radio Listeners' Guide," "Spare-Time Money Making" and "Amazing Stories."

H. GERNSBACK, President. S. GERNSBACK, Treasurer. R. W. DEMOTT, Secretary.

Member: Audit Bureau of Circulations Radio Magazine Publishers Association

Editorial and General Offices: - - 230 Fifth Avenue, New York City

VOLUME 9

JULY, 1927

NUMBER 1

Contents of This Issue:

Wired vs. Space Radio, By Hugo Gernsback	11	How Motor Patrol Wars with Bloopers, The Acme "D"-Coil Receiver, By Joseph Riley	37 38
The Service Area of a Broadcast Station, By S. R. Winters	12	A Simple Roll-type Loud Speaker, By E. M. Yarbrough	41
Radio News of the Month, Illustrated, By George Wall	14	The "Ham's Own" Short-Wave Receiver, By John L. Reinartz	42
The Fly in the Ointment, By Nellie Barnard Parker	15	A Compact Traveler's Set, By Herman F. Swartz	44
What's New in Radio	16	Building a Remote-Speaker Cabinet, By Herbert C. McKay	47
\$250 Prize Contest—What is the Best Title You Can Suggest for Our Cover Illustration?	20	Short Waves Round the Earth	49
Stereophonic Hearing	20	A New Electron Tube, By Sylvan Harris	50
Radio News of the Month	21	How the Deaf Hear Radio	51
He Bloops to Conquer, By Robert Francis Smith	22	The Effects of Shielding, By Harold A. Zahl	52
The Time Chime at WRNY, By Hugo Gernsback	24	Correspondence from Readers	53
Loud-Speaker Coupling Devices, By I. F. Jackowski	25	Letters from Home Radio Set Constructors	54
Some Aspects of High-Quality Reproduc- tion (Part I), By Paul Traugott	26	Radiotics	55
The Strobodine Circuit, a New Frequency- Changer (Part I), By Lucien Chrétien	28	Radio Wrinkles—Awards of \$50 Prize Contest	56
What Can You Do With Burnt-Out Tubes? \$100 Prize Contest,	30	RADIO NEWS LABORATORIES	58
An Effective Method of Regeneration Con- trol, By Thomas L. McKay	31	Short-Wave Experiments with Ultra-Violet Rays, By A. Riechers	59
Light-Sensitive Crystals, By G. C. B. Rowe	32	Progress in Radio	60
An 18- to 1500-Meter Receiver, By L. W. Hatry	34	I Want to Know, By Joseph Goldstein	61
		Radio Jingles	72
		Hours for DX Work, By A. B. Marshall	85
		New QRAs—Calls Heard	86
		Current Radio Articles	91
		Book Reviews	93

In Forthcoming Issues:

THE STROBODINE RECEIVER

A set utilizing this, the outstanding circuit of the year, will be described in the August issue, with full constructional details.

SHORT-WAVE CONVERTER FOR A BROADCAST RECEIVER

With this two-tube unit in front of your regular receiver, it will be possible for you to pick up stations operating on low wavelengths.

A DOUBLE-IMPEDANCE A.F. AMPLIFIER

One of the greatest advances that have been made in A.F. amplifiers will be illustrated in the constructional article on this unit, which was developed by E. E. Hilier.

RADIO NEWS is published on the 10th of each preceding month. There are 12 numbers per year. Subscription price is \$2.50 a year in U. S. and possessions. Canada and foreign countries, \$3.00 per year. U. S. Coin as well as U. S. Stamps accepted (no foreign coins or stamps). Single copies, 25 cents each. Checks and money orders should be drawn to order of EXPERIMENTER PUBLISHING CO., INC.

All communications and contributions to this journal should be addressed to Editor, RADIO NEWS, 230 Fifth Ave., New York, N. Y. Unaccepted contributions cannot be returned unless full postage has been included. All accepted contributions are paid for on publication. A special rate is paid for novel experiments; good photographs accompanying them are highly desirable.

RADIO NEWS, Monthly. Entered as second class matter, July 12, 1924, at the Post Office at New York, N. Y., under the Act of March 3, 1879. Additional entry at Long Island City, N. Y., and San Francisco, Calif. Title registered U. S. Patent Office. Copyright, 1927, by The Experimenter Publishing Co., Inc., 230 Fifth Ave., New York. The Contents of this magazine are copyrighted and must not be reproduced in the United States without giving full credit to the publication. Translation into foreign languages must not be made unless permission is obtained from the publishers. Copyrighted in Germany. Reproduction of articles in Germany is reserved for Radio, Berlin 42.

RADIO NEWS is for sale at all newsstands in the United States and Canada, and at Brentano's, Ave. de l'Opera, Paris, France. European agents: S. J. Wise & Co., 40 Place Verte, Antwerp, Belgium.

HOW TO SUBSCRIBE FOR RADIO NEWS. Send your name, address and remittance to Experimenter Publishing Co., 230 Fifth Ave., New York. Mention the name of the magazine you are ordering. We also publish SCIENCE AND INVENTION, RADIO PROGRAM WEEKLY, RADIO LISTENERS' GUIDE, SPARE-TIME MONEY MAKING and AMAZING STORIES. Write clearly.

RATES AND TERMS. The subscription rate for RADIO NEWS is \$2.50 per year (12 numbers). When remitting do so by check, money order, or registered letter if cash is enclosed. Avoid sending cash through the mail if possible. Subscriptions for less than one year are not accepted. Subscription may be made in combination with SCIENCE & INVENTION, RADIO PROGRAM WEEKLY, RADIO LISTENERS' GUIDE, SPARE-TIME MONEY MAKING and AMAZING STORIES.

POSTAGE. We prepay postage in all parts of the United States, Mexico and island possessions. For foreign or Canadian subscriptions we require 50 cents in addition to the subscription price for additional postage charge.

CHANGE OF ADDRESS. Notify us as far in advance as possible. It requires several weeks to make an address change on our records. Always write clearly.

General Advertising Dept., 230 Fifth Avenue, New York City

ADVERTISING REPRESENTATIVES

L. F. McCLURE, 720 Cass Street, Chicago, Ill.
DAVIES, DILLON & KELLY, 15 West 10th St., Kansas City, Mo.
T. F. MAGRANE, Park Square Bldg., Boston, Mass.

HARRY E. HYDE, 548 Drexel Building, Philadelphia, Pa.
A. J. NORRIS HILL CO., 5 Third St., San Francisco, Calif.
412 West 6th St., Los Angeles, Calif.

Drum notes not only heard — but identified

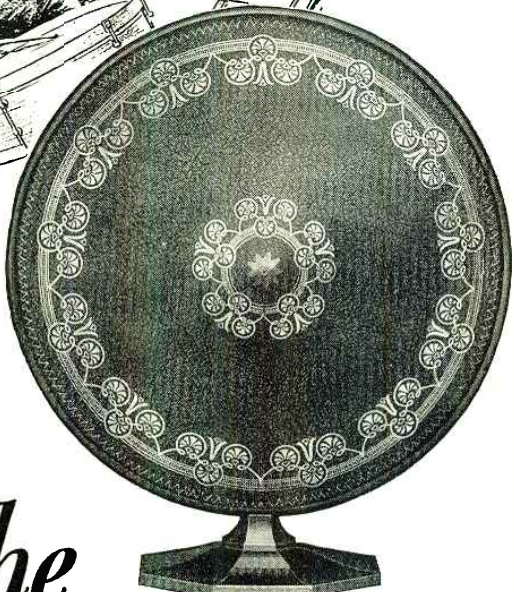
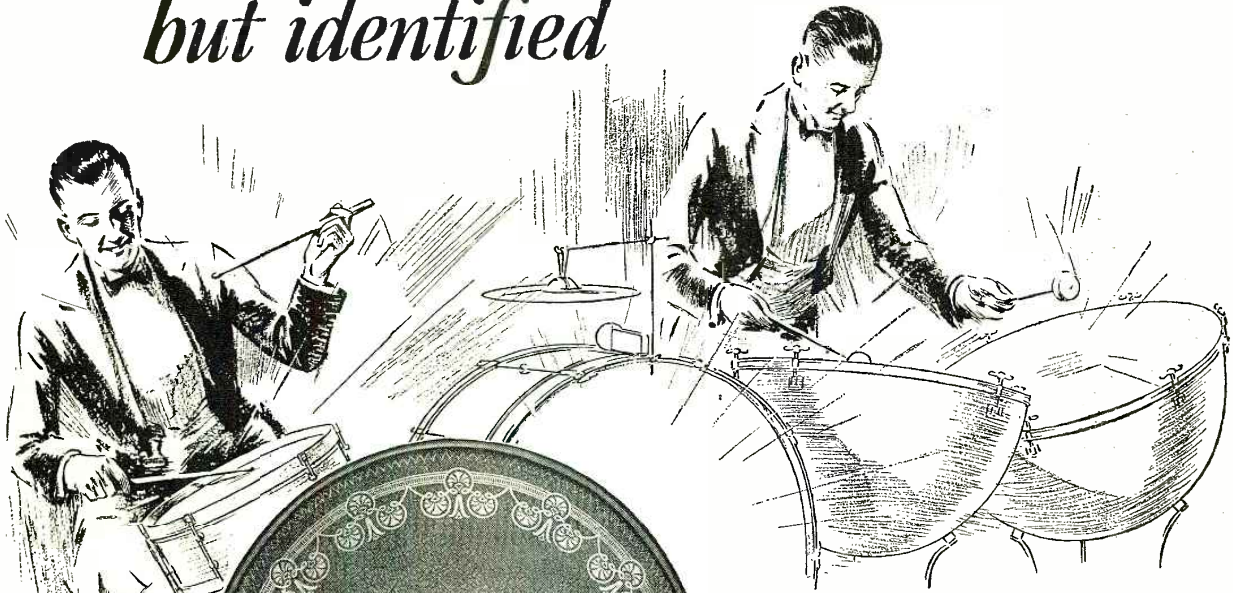

THOUSANDS of radio listeners will now realize for the first time that radio orchestras have drums when they hook up this new, improved Crosley Musicone.

As originally produced the Musicone startled the radio world, eclipsing the old type horn and squeaky speaker.

Today, the new Musicone with its latest refinements and improvements correspondingly leads its host of imitators.

Prepare for a real surprise when you hear this amazing device with its beauty and fidelity of treble reproduction—clarity and breathless reality in middle tones—richness and resonance of bass. Today—ininitely bettered and superlatively developed, the Musicone is the world's finest loud speaker—and, at such extremely low prices, it's the world's greatest radio value.

The Crosley patented actuating unit (and *not* the cone) is the secret. There's nothing else like it.

Write Dept. 22 for descriptive literature.

The improved

CROSLEY MUSICONE

SUPER-MUSICONE
16 inch Cone
\$14.75

THE CROSLEY RADIO CORP.

Powel Crosley,
Jr., Pres.



Cincinnati,
Ohio.

Prices slightly higher west of the Rocky Mts.

ULTRA-MUSICONE
12 inch Cone
\$9.75



“MEN! Here's the 'dope' you've been looking for

HOW TO GET INTO THE RADIO BUSINESS”

J.E.S.

EARN BIG MONEY in Work That is Almost Romance

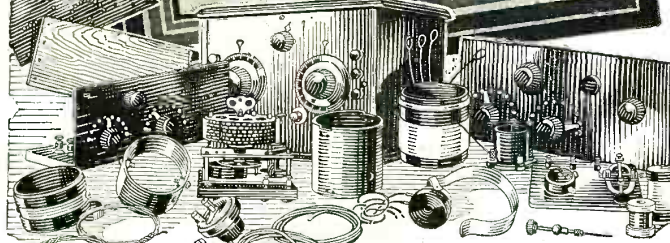

BIG RECEIVING OUTFIT INCLUDED IN COURSE



J. E. SMITH
President

Instruments shown here and others—sent to our students free of extra cost.

Clip coupon now—find out all about this big unequalled offer while you still have time to take advantage of it. Our training is intensely practical—these instruments help you learn to do the practical work. Receiving sets, from simplest kind to thousand-mile receiver. Many other big features.

My Radio Training Is the Famous “Course That Pays for Itself”

Spare time earnings are easy in Radio when you know it the way we teach you. Increase your income almost from the start of your course thru practical knowledge we give you. We show you how to hold the job, then our Employment Department helps you get one. Free book “Rich Rewards in Radio” tells how.

Howard B. Luce of Friedens, Pa., made \$320 in 7 weeks during his spare time. D. H. Suitt of Newport, Ark., writes, “While taking the course I earned in spare time work approximately \$900.” Earl Wright of Omaha, reports making \$400 in a short time while taking his course—working at Radio in his spare time only. Sylvester Senso, 207 Elm Street, Kaukauna, Wis., made \$500.

And when your training is completed you're ready to step into a real big Radio job like C. C. Gielow, Chief Operator of the Great Lakes Radio Telegraph Company; E. W. Novy, Chief Operator of Station WRNY; Edward Stanko, Chief Operator of Station WGR; and hundreds of other N. R. I. Trained men. The National Radio Institute, originators of Radio Home-Study Training, established 1911, today offers you the same opportunities these men had, under a contract that pledges you full satisfaction or money refunded on completing our training. It's your big chance to get into Radio—mail coupon for FREE Book and proof.

If you're earning a penny less than \$50 a week, clip coupon now for FREE BOOK! New Book, 64 pages, profusely illustrated, tells all about the Radio profession, thousands of opportunities—in work that is almost romance! YOU can learn quickly and easily at home, through our tested, improved methods, to take advantage of these great opportunities! Why go along at \$25 or \$35 or \$45 a week, when you can pleasantly and in a comparatively short time learn to be a Radio Expert, capable of holding the big pay jobs?

Clip Coupon for Free Book

Don't envy the other fellow who's pulling down the big cash! Our proven home-study training methods make it possible for you, too, to get ready for a better job, to earn enough money so you can enjoy the good things of life. One of the most valuable books ever written on Radio tells how—interesting facts about this great field, and how we can prepare you, quickly and easily in your spare time at home, to step into a big-pay Radio job. You can do what others have done through our training. GET THIS NEW FREE BOOK. SEND COUPON TODAY.

J. E. SMITH, President
NATIONAL RADIO INSTITUTE
Dept. GB-9 WASHINGTON, D. C.

Coupon Brings Free Book Mail It NOW!



National Radio Institute
Dept. GB-9
Washington, D. C.

Dear Mr. Smith: Without obligating me in any way, send me your FREE BOOK, “Rich Rewards in Radio,” and all information about your practical, home-study Radio Course.

Name.....

Address.....

Town State.....

SEND THIS COUPON TODAY

BOSCH

The New Bosch Radio Models are built, not only for customer satisfaction but for dealer profit as well. They are "transportation proof". So strongly are they constructed that they may be delivered to the customer with the original factory settings—without adjustment by the dealer. To be convinced of Bosch Superiority, examine the steel chassis, the condenser unit assembly with its three point mounting, the short solid connections, the locked assembly and the elimination of solder operations. All models have Single Station Selector—electrically lighted—Bosch—RFL circuits—are armored and shielded and are priced for volume sale. The new cabinets present a new beauty in design, craftsmanship, selection and finish of fine woods. Appearance and performance are so ably handled and the price range so attractive that Bosch is the outstanding dealer line this year. The Bosch Dealer Policy is liberal and it is strongly supported. It offers unusual possibilities to Radio Dealers who are in business to stay. It is well worth investigating. Tell us in confidence about yourself, business standing financial strength and plans regardless of the lines you now carry. We will be glad to tell you of our plans for your locality.

AMERICAN BOSCH MAGNETO CORP.
 MAIN OFFICE AND WORKS: SPRINGFIELD, MASS.
 BRANCHES: NEW YORK CHICAGO DETROIT SAN FRANCISCO



AMERICAN BOSCH MAGNETO CORPORATION

Manufactured under patent applications of the American Bosch Magneto Corporation and licensed also under applications of the Radio Frequency Laboratories, Inc.

RADIO



Model 76—Six tubes, Bosch RFL circuit—single station selector, Bosch Line O'Lite tuning, wired for battery or socket power operation armored and shielded, spacious power unit compartment, solid walnut cabinet beautifully finished with and without built-in reproducer. With built-in reproducer . . . \$195.00
Without built-in reproducer . . . \$175.00



Model 57—Seven tubes, Bosch RFL circuit efficient built-in loop, built-in 18 in. reproducer, walnut cabinet with selected pattern woods, spacious power unit compartment. Single station selector, electrically lighted dial, Bosch Line O'Lite tuning, armored and shielded, wired for battery or socket power operation and operates on loop or wire antenna from two to two hundred feet. Price with built-in loop, built-in reproducer . . . \$340.00



Model 66—Six tubes, Bosch RFL circuit—single station selector, electrically lighted dial, Bosch Line O'Lite tuning, armored and shielded, wired for battery or socket power operation, solid walnut cabinet—beautifully finished Ideal table type receiver, price . . . \$99.50

THE BOSCH NOBATTERY "A" POWER UNIT

—for converting house current into "A" power for radio receiver operation. Typically Bosch, its construction, both mechanical and electrical is of highest grade and its performance is a revelation. The outstanding features of the Bosch Nobattery "A" are:

- Constant voltage
- Unvarying power
- Quiet
- Instantaneous—no heating delay
- No harm if left "On"
- Nothing to boil over
- No chemicals to add
- Economical in current draw
- No power dissipated in heat—uses power efficiently as power
- Receiver does not need to be rewired
- Small in size—can be put in radio cabinet like a battery

The Bosch Nobattery "A" is a perfect companion to the famous Bosch Nobattery "B". These two units form an ideal combination for supplying "A" and "B" current and retail for \$100.00.

Bosch Radio—the Complete Dealer Line

Model 57—Seven-tube Receiver, Single Dial, cabinet type, loop operated—built-in reproducer—wired for battery or socket power operation . . . \$340.00

Model 76—Six-tube Receiver, Single Dial, cabinet type—wired for battery or socket power. With built-in speaker . . . \$195.00

Without the built-in speaker . . . \$175.00

Model 66—Six-tube Receiver, Single Dial, table type, wired for battery or socket power . . . \$99.50

Ambotone Reproducer—Cone Type, Table Reproducer, with years of recognition for its perfect tonal reproduction . . . \$27.50

Nobattery—"A"—An ideal socket power device, supplying "A" current for all sets up to ten tubes—no acids, no moving parts, no hum, no trouble, no heating delay. . . . \$58.00

Nobattery "B"—Famous Bosch Nobattery for supplying "B" Power for all sets up to ten tubes—no acids, no hum, long lived . . . \$42.00

Powertrol—Prevents direct current passing from radio receiver into reproducer with consequent damage. Prevents distortion and destruction in speaker. Should be sold to every power tube user \$8.00.

Recreator—A truly successful three unit device for providing electric reproduction of phonograph records—utilizes any style phonograph and reproduces through a radio receiver and loudspeaker \$20.00.

All these Bosch Radio Models—ready for Bosch Socket Power Units—the Nobattery "A" and the Nobattery "B"—both totaling \$100.

All prices slightly higher, Colorado and west, and in Canada.



Mechanics—in the "Ole Swimmin' Hole"!

all in the
JULY
ISSUE

NOW
READY

25¢
the Copy



WANT to make the old swimming hole a real place of recreation? Learn how to build your own new fashioned spring, a catapult that's a duplicate of those used on Uncle Sam's Warships—on a small scale, and even a water merry-go-round. The biggest novelty of the season. All these can be made at home— from the complete instructions given in the July issue of **SCIENCE and INVENTION**. Don't miss it.

AERIAL FIRE FIGHTERS

As the great buildings go up 20, 30, 40, 50 stories or more the problem of fire fighting becomes acute. **SCIENCE and INVENTION** has some very novel and practical solutions, including the use of aeroplanes. Every line of this article is intensely interesting.

NEW PICTURE TRANSMISSION

The new invention of Captain Ranger, the famous expert, is described in the July issue of **SCIENCE and INVENTION**. It includes a very much improved system of picture transmission by Radio or land wires that permits enlargements or pictures en route. It is a truly marvelous article. No one can afford to miss it.

100 PAGES OF ARTICLES

There are 100 pages or more of similar articles in this issue. All illustrated. Many Radio Features, too, and new circuits and accessories. **SCIENCE and INVENTION** is the magazine of the World Progress.

25c THE COPY EVERYWHERE

EXPERIMENTER PUBLISHING CO., Inc., 230 FIFTH AVE., N. Y.

Subscriptions
\$2.50 the year.
Send in your subscriptions **NOW**.

8 BIG AMAZING STORIES

--featuring--

—THE OTHERS—

- The Ethership of Oltor
By S. Maxwell Coder
- The Voice from the Inner World
By A. Hyatt Verrill
- The Gravimobile
By D. B. MacRae

RADIO MATES

By BENJAMIN WITWER

"Think of it! A twist of a switch and the living, breathing animal is slowly dissolved before your eyes and vanished along a pair of wires to a radio whence it is transferred as a set of waves in the ether to the receiving apparatus—there to reincarnate into the living organism once more, alive and breathing, unharmed by its extraordinary journey!"

The inventor of the above apparatus then decides to transmit his long loved mate by the same phenomenal manner as were the animals, but—why spoil the terrible climax. Read it in the big July issue of **AMAZING STORIES**.

- The Moon Pool
By A. Merritt
- The Lost Continent
By Cecil B. White
- The Plattner Story
By H. G. Wells
- Von Kempelen and His Discovery
By Edgar Allan Poe

- Editorial
By H. Gernsback
- Readers' Department
For Discussions



July Issue---On Sale Everywhere

25c THE COPY — \$2.50 THE YEAR

If your dealer cannot supply you, order direct

EXPERIMENTER PUBLISHING CO., Inc.,—230 5th Ave., New York

SUCCESS

from

CHEMICAL INSTITUTE OF NEW YORK
16 East 30th Street, New York City.

Mountoursville, Pa.

Gentlemen: I must tell you the success I have had since taking your chemistry course. My salary has been increased several times, and different industrial plants are coming to me for a little advice on different things, netting me a fair side income.

I am only sorry that I did not make My whole life study of the wonderful science.

(signed) *M. E. Van Sickle.*

CHEMISTRY

NOW
is the Time to Study
Chemistry

Not only are there boundless opportunities for amassing wealth in Chemistry, but the profession affords congenial employment at good salaries to hundreds of thousands who merely follow out its present applications. These applications are innumerable, touching intimately every business and every product in the world. The work of the chemist can hardly be called work at all. It is the keenest and most enjoyable kind of pleasure. The days in a chemical laboratory are filled with thrilling and delightful experimentation, with the alluring prospect of a discovery that may spell fortune always at hand to spur your enthusiasm.

Easy Monthly Payments

You don't have to have even the small price of the course to start. You can pay for it in small monthly amounts—so small that you won't feel them. The cost of our course is very low, and includes everything, even the chemistry outfit—there are no extras to buy with our course. Our plan of monthly payments places a chemical education within the reach of everyone. Write us and let us explain our plan in full—give us the opportunity of showing you how you can qualify for a highly trained technical position without even giving up your present employment.

CHEMISTRY has no equal as a profession in the modern world. There is mystery, romance and fortune awaiting the man in the laboratory.

Millions have been made by the discoverers of the chemical formula of dynamite, bakelite and many other world known chemical products.

Opportunities in the chemical profession abound on every hand—and as modern business and competition progresses the chemist will play an important part.

Profit by the experience of Mr. Van Sickle and many others, resolve to study chemistry NOW.

YOU CAN LEARN AT HOME

To qualify for this remarkable calling requires elaborate specialized training. Formerly it was necessary to attend a university for several years to acquire that training, but thanks to our highly perfected and thorough system of instruction, you can now stay at home, keep your position, and let us educate you in Chemistry during your spare time. Even with only common schooling you can take our course and equip yourself for immediate practical work in a chemical laboratory. Dr. Sloane gives every one of his students the same careful, personal supervision that made him celebrated throughout his long career as a college professor. Your instruction from the very beginning is made interesting and practical, and we supply you with apparatus and chemicals for performing the fascinating analyses and experimental work that plays such a large part in our method of teaching, and you are awarded the Institute's official diploma after you have satisfactorily completed the course.

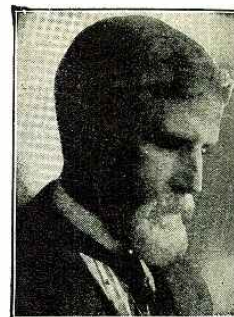

T. O'CONOR SLOANE,
A.B., A.M., LL.D., Ph.D.

Noted Instructor, Lecturer and Author. Formerly Treasurer American Chemical Society and a practical chemist with many well known achievements to his credit. Not only has Dr. Sloane taught chemistry for years but he was for many years engaged in commercial chemistry work.

Special 30 Day Offer

Besides furnishing the student with his Experimental Equipment, we are making an additional special offer for a short while only. You owe it to yourself to find out about it. Write today for full information and free book "Opportunities for Chemists." Send the coupon right now while it is fresh in your mind. Or just write your name and address on a postal and mail it to us. But whatever you do, act today before this offer is withdrawn.

DON'T WAIT—MAIL COUPON NOW!

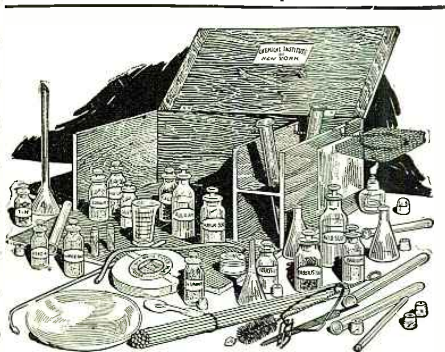

EXPERIMENTAL EQUIPMENT FURNISHED TO EVERY STUDENT

We give to every student without additional charge this chemical equipment, including forty-nine pieces of laboratory apparatus and supplies, and forty different chemicals and reagents. These comprise the apparatus and chemicals used for the experimental work of the course. The fitted heavy wooden box serves not only as a case for the outfit but also as a useful laboratory accessory for performing countless experiments.

Chemical Institute of New York

Home Extension
Division 7
16-R- East 30th St.
New York, N. Y.

CHEMICAL INSTITUTE OF NEW YORK
Home Extension, Division 7
16-R—East 30th Street, New York City.

Please send me at once, without any obligation on my part, your free Book "Opportunities for Chemists," and full particulars about the Experimental Equipment given to every student. Also please tell me about your plan of payment and your special 30 day offer.

NAME

ADDRESS

CITY STATE

R.N. July, '27

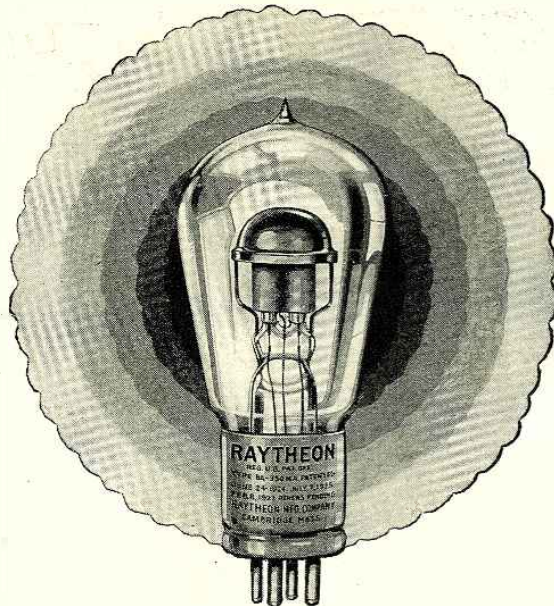

BA

350 MILLIAMPERES

Complete Battery Elimination!

THIS one tube—the latest Raytheon achievement—provides noiseless, dependable ABC power from any light socket. The radio constructor can build a first class receiver using any of the standard radio circuits and incorporating this tube (with transformer, filter, etc.) to furnish *all* the power. Its 350 m.a. and 200 volts is more than adequate for the largest receiver, using power amplification.

Manufacturers of receivers and eliminators employing the BA

tube will announce their new developments in the near future. If they bear the Raytheon seal of approval you are assured of design and construction that has successfully met Raytheon's rigid standards.

Complete technical information on design and operation of series filament receivers using this remarkable tube will be sent free by our Technical Service Bureau on request. Ask for Radio Power Bulletin SF-1. You may obtain the tube and approved parts at your dealer's. Tube Price—\$7.50.



TYPE BH—85 m.a.

RAYTHEON BH—85 m.a. is designed for heavy duty applications of light socket power. Its introduction made possible the remarkable developments of power amplifiers and complete A. C. operated receivers using 199 tubes connected in series.

Rating: 85 m. a. output at 200 volts.



RAYTHEON A
2½ Amperes

The Last Word in High Current, Low Voltage Rectification

A new type of rectifier, revolutionary in principal—appearance—performance. It is compact and simple, contains no liquids or filaments, and is enclosed in an unbreakable metal casing. The size and ability of Raytheon A makes possible the *smallest and most efficient* battery charges and A power units. Leading radio manufacturers are designing apparatus to make full use of this new discovery.

RAYTHEON MANUFACTURING COMPANY
Cambridge, Massachusetts



TYPE B—60 m.a.

RAYTHEON B—60 m.a. is the recognized standard for most of the B-power units now in use. Within the service for which it is rated, this rectifier is not surpassed by any rectifier made.

Rating: 60 m.a. output at 150 volts.

Raytheon

THE HEART OF RELIABLE RADIO POWER



RADIO NEWS

HUGO GERNSBACK,
Editor and Publisher

Editorial and General Offices, 230 Fifth Avenue, New York

Vol. 9

JULY, 1927

No. 1

WIRED US. SPACE RADIO

By HUGO GERNSBACK

WHEN broadcasting was established in this country, the universal opinion was that the service would always be free. No one in America has ever seriously considered broadcasting for pay from the listeners. This is in distinct contrast to the European system, whereby every radio set is taxed by the government anywhere from 25 cents a month upwards to pay the broadcasters. This is the custom that prevails in most countries of the world with some few exceptions. Of course, even in the United States, some one foots the bill—that some one being usually the public. But this is indirect taxation, whereas the European system is one of direct taxation on each set.

In America the broadcasters expect to get back, through the returns from good-will programs or indirect advertising, their outlay for broadcasting—in which effort, it may be said, they have been fairly successful. Not every station, however, operates at a profit, nor will probably do so for some time to come. In general, the principle has been recognized in this country that radio should be free for all, so that any one by buying a set can listen in to his heart's content, year in and year out. This is the prevailing system of space radio.

There is, however, another system which may shortly go into operation in the eastern part of the United States, and which is known under the name of *wired radio*. There is nothing new about this, for it is not a new invention by any means.

General G. O. Squier took out patents on wired radio many years ago, but so far the system has not met with much success or encouragement in application to broadcasting; although this can be accomplished by wired radio over any existing lines, be they telephone or telegraph, electric-light or power. It is understood that, for the time being at least, the telephone interests will have none of wired radio. On the other hand, one of the largest electric light and power corporations in the country, with networks extending throughout the east, definitely intends to go "on the wire" with wired broadcasting in the near future, probably within six or eight months.

Many technical difficulties had to be overcome to make this possible, but officials of the company sponsoring wired radio now believe that the difficulties have been smoothed out, and that a real service can actually start very soon. Somewhere in the east there will be studios where three different programs will be broadcast simultaneously on different wavelengths over existing wire systems.

By means of a simple switch on a special receiving set, it is promised, the listener renting the instrument from the wired-radio company will be able to select any one of the three programs being fed to the electric-light wires, and this program will issue from a loud speaker. Two models of receivers are planned. One will use a crystal detector, and is intended primarily for headphone reception. The other will include a regular audio amplifier and a loud speaker, all "A," "B" and "C" power being derived from the power line. No aerial and ground will be used, as the receiver picks the programs directly off the power wires.

If one already owns a radio receiver, he can rent the crystal receiver and connect it to his set in such a manner that the audio amplifier in the latter will amplify the signals; the radio loud speaker will then reproduce them as it does space-radio impulses. This is just an outline of the proposal, from the advance information at hand.

Interesting as are the possibilities of wired radio, however, I per-

sonally do not believe that it will prove a formidable competitor of space radio.

It may be said, as a matter of fact, that the so-called wired radio really should not be called radio at all, although it uses radio instrumentalities throughout. In any event, wired radio certainly takes the romance and thrill out of radio broadcast reception, unless you are satisfied with one or two local stations. With space radio even a mediocre set has no trouble tuning in any evening at least forty or fifty stations; and if the set is a really good one, as many as a hundred stations can be logged.

This does not mean, of course, that you can enjoy a hundred different programs during that evening, because the time limitation is against this. But the argument remains in favor of space radio; for the simple reason that, if you wish to stay with any one on the programs, you can do so by tuning in the station you wish to listen to and, unless it is an exceptionally bad night, when much static prevails, there is not much difficulty in staying with the station selected. If I do not wish to know what is going on in Chicago, I can listen to Washington or to New York, or to Atlanta. That is, with space radio. With wired radio it would seem that there must be limitation to a very few programs. The fact is, you will have to take what you get. This seems to be a serious disadvantage, and only time will tell whether it can be successfully overcome.

On the other hand, it may be said that, with wired radio, you do not have to contend with static and uncertainties, but you may be assured of a program at all times. How this choice will strike the average listener it is, of course, impossible to predict.

Then comes the most important point under consideration; and that is, *wired radio will not be free*. The apparatus will not be sold, but leased at a certain monthly rental per instrument.

Just how many people will avail themselves of such a service, when general radio entertainment always has been free, remains as yet to be seen. While there can be no doubt that wired radio will in all probability never supplant space radio, it is possible that it will prove an interesting adjunct to space radio. The parallel to this may be found in space radio and the phonograph.

When radio first came into vogue it was freely predicted that the phonograph would speedily be relegated to the scrap heap. I predicted editorially in *RADIO NEWS*, early in 1921, when broadcasting first started, that nothing of the kind was apt to happen, and rather that the phonograph would be helped by radio. This indeed proved to be the case, for there are more phonographs and more records being sold today than there were at any time.

I do not believe that it will be at all practicable, as suggested, for the wired-radio companies to establish a method of secret transmission over their lines, so that only the apparatus rented from them will be capable of receiving their programs; because, the moment apparatus is installed and the nature of the device becomes public, every radio constructor will surely try to build a set by means of which he can tune in on the wired radio.

It is in the nature of every radio fan to investigate and the prediction is freely made that, if wired radio comes into universal use, the parts business will take a sudden leap. Every radio fan and every set builder will no doubt try, at one time or another, to build a radio receiving set that will bring in the wired-radio programs. It seems that the wired-radio interests will be powerless to prevent this; because there is no law on the subject, and because the "boot-leg" listener would be stealing nothing.

In which the Editor discusses the American system of free broadcasting and its alternatives—and the possibilities of the proposed "wired radio"—which is coming soon—and doubts that the latter can supersede DX radio reception in the favor of true fans—and expresses the opinion that wired radio will be an immediate challenge to the well-known ingenuity of myriad radio constructors—why there is room for both services to the great radio public.

Mr. Hugo Gernsback speaks every Monday night at 9 P. M. from station WRNY on various radio and scientific subjects.

The Service Area of a Broadcast Station

Uncle Sam Makes Tests on Signal Strength and the Effects of Steel Buildings

By S. R. WINTERS

WHILE broadcast stations have been heard nearly half-way around the world, the area in which every listener can absolutely depend on getting a certain one with full volume and perfect quality is very much smaller than you might think. The government has been making some tests along these lines; and some surprising facts about local interference and absorption are set forth in this article.—EDITOR.

THE age-old analogy of a pebble, thrown into a pond, producing ripples spreading equally in all directions, and a like disturbance caused in the ether by a radio wave from a

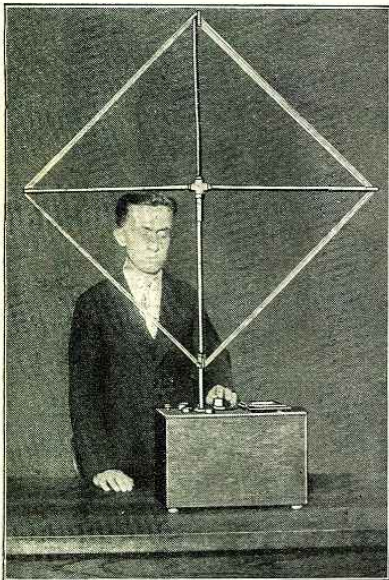

Mr. Edwards with a testing equipment, measuring signal strength from a nearby station.

broadcast station is subject to revision. For schoolroom or laboratory demonstration purposes, the analogy is sufficiently accurate to stand, but in actual conditions the splash of a wave in the area around a transmitting station does not always produce a circular disturbance. Steel buildings and electric-wire networks may intervene and cause irregularities of wave radiation so marked as to border on deformity.

Strikingly illustrative of this is the result of the measurements of signal strength of WTAM, a broadcast station of Cleveland, Ohio. In an easterly direction, along the lake shore, the signals may be heard with remarkable clarity and dependability up to a distance of 30 miles. In a westerly direction, however, signals of a like intensity are not received over a greater distance than 10½ miles. Another example of the dwarfed formation of radio waves: WSB, a broadcast station of Atlanta, is hedged in from one direction by so formidable a group of steel structures that the effective radius of its powerful transmitter is restricted to a few miles in a circle, taking into account all of the adverse reception conditions of day and night, winter and summer.

These fragmentary reports, as well as complete detailed information on the effective radiating capacity of four broadcast stations, located in different sections of the country, are included in results of investigations made by S. W. Edwards, radio supervisor at Detroit, Michigan. Using his \$4,000 radio test car—a complete radio transmitting and receiving station on wheels—Mr. Edwards has done some pioneer work in establishing radio-reception zones, which have been termed “complete service areas.” The Secretary of Commerce, Herbert Hoover, has defined these areas as being “the territory within which the average receiving set can depend upon getting clear, understandable and enjoyable service from the station day or night, summer or winter.” He adds, “I do not include radio golf around the edges of these areas in our conception of public service; that game is an exercise of skill and the efficiency of your set plus a gamble on the radio weather.”

The field intensity measurements of Mr. Edwards covered four broadcasting stations: WRC of Washington, D. C.; WTAM of Cleveland, Ohio; WSB of Atlanta, Georgia, and WGHP of Detroit, Michigan. Observations on two or three of these stations extended over a period of several months, thus noting the adverse as well as favorable conditions for radio reception. The tests were made during daylight and in establishing these “complete service areas” the restricted carrying capacity of waves entered into the calculations, as well as such primary natural obstacles as static and fading of signals. In radio engineering terms, Mr. Edwards used the working standard of 10,000 or more microvolts per meter intensity. In simple terms, this means that if the signals registered this intensity they were of sufficient strength to override noise levels—static, electrical disturbances, etc.

Three major factors were studied as influential conditions around the transmitting stations in determining the “complete service

area” at the receiving stations. These were: steel structures and electrical networks, the

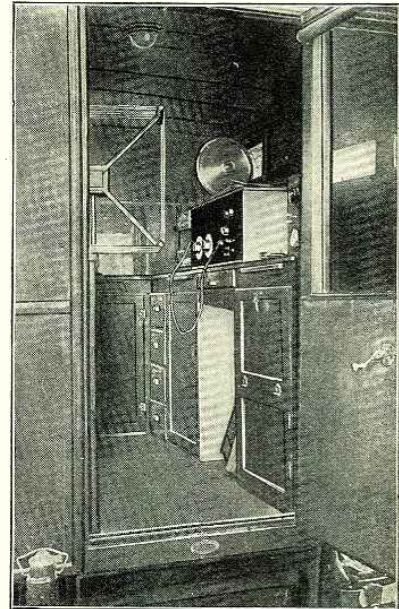

The interior of the radio inspector's automobile receiving station, with a glimpse of some of its elaborate equipment.

aerial, and the ground system. The latter took into account the terrain in the vicinity of the broadcasting station and the location of any bodies of water in its vicinity. Generally speaking, steel structures in our large cities, when contiguous to broadcast stations, are determining factors in reducing the strength of signals in certain directions. Mr. Edwards uses a pleasing simile to demonstrate this point. He says, “Shadowing a radio station with tall buildings means that it becomes an exact analogy of a lamp with some object placed near it to throw a shadow.” Results of these investigations corroborate previous conclusions to the effect that radio waves have a greater carrying capacity over water than when traveling over land; lakes, rivers, and oceans seem to have a tonic effect on the waves, as it were. Faulty antenna systems and poor ground conditions at the broadcast stations, no less than at the receiving stations, limit the effective radius of the propagated waves.

The field strength of WRC, a station operated in Washington, takes the strange form of a spherical triangle; the three angles of the triangle following the water courses of the three divisions of the Potomac River. Transmission is slightly better in a southerly direction, but the wave radiates with reasonable uniformity in all directions. This would seem to indicate that the disturbance produced in the ether by the wave of this station is more analogous to the ripple created by a stone thrown into a pond than the waves of many broadcast stations. That is, it is little affected by shadowing and absorptive effects, so common with most stations in metropolitan areas. These field intensity measurements did not take into consideration the poor tonal quality of the transmission of this station. The modulation has become so inferior that local radio fans are vociferous in their complaints.

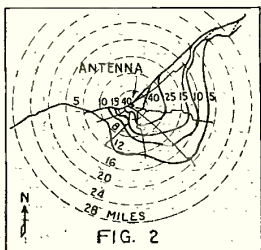

FIG. 2

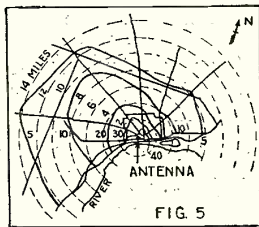

FIG. 5

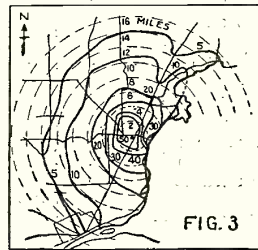
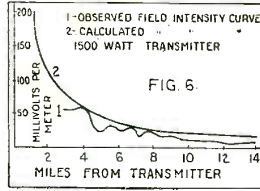
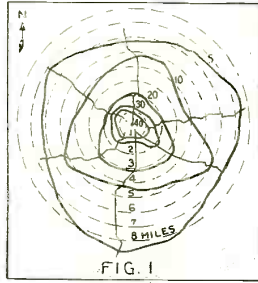

FIG. 3

Fig. 2 is the field of a Cleveland station, showing how much better is the reception along the lake shore. Fig. 5 is the field of a station in Detroit itself, and Fig. 3 that of another well outside the city limits, showing how much less the latter is hampered by building interference. Yet the absorption caused by public-utility lines in a N.E.-S.W. direction is clearly indicated.



Illustrations of station-intensity fields from the Radio Service Bulletin of the Department of Commerce.

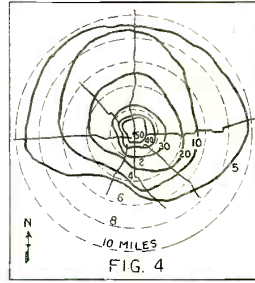

Fig. 1 shows the comparatively even distribution of signal strength in Washington, a city of few high steel buildings. Fig. 4 shows conditions in Atlanta, with the "shading" caused by its business district. Fig. 6 shows the normal curve of decreasing signal strength. The heavy lines on these diagrams are contours of equal signal strength, measured in millivolts per meter. 10 millivolts (10,000 microvolts) the 10-line in these figures, outlines the 100%-service area as estimated by the Department of Commerce in this published survey.

WTAM, a Cleveland broadcast station, radiates signals that are heard clearly and consistently over a reasonably wide area. Exacting field intensity measurements afford results in agreement with this statement. This station is located on the 20th floor of the Union Trust Company Building and the power used approximates 5,000 watts. Subject to the rigid standard of the so-called "complete service area," signals of this station may be heard in certain directions and at all times over an area of 259 square miles. The transmission in westerly and southerly directions is considered very poor and the Government investigators compare the results of this 5,000-watt station in those directions to the effectiveness of a 500-watt station. Signals traveling along the lake shore have great carrying capacity, and are heard at considerable distances with dependable regularity.

Station WGHP, of Detroit, demonstrated a reliable reception area of 228.3 square miles in these field intensity measurements. The power used is 1,500 watts. After making measurements in many directions, Mr. Edwards stated that the transmission of this station established "a good service area." In defining his standard of measurement, he stated: "It is believed that at the present time that the signal strengths of 10,000 microvolts per meter and above are those which furnish absolutely reliable, high quality reception, of a standard comparable to a musical instrument in that the signal is so much stronger than the ordinary noise level of reception that reproduction is clear, loud and dependable."

WSB, of Atlanta, Georgia, under favorable night time reception conditions radiates signals that are heard across the continent and even in foreign countries. And, yet, a group of tall steel buildings located in the southern part of the city serves as such an effective barricade to radio waves that the effective radius of the signals of this station during the daytime and under adverse conditions is restricted to a few miles. In fact, the "complete service area" is so limited—from 3.5 to 9 miles—that the results of these measurements are almost incredible. Instead of applying to a 1,000-watt station, this "service area" might in other locations fit the results of a 250-watt station. The mass of steel structures in southern Atlanta and the location of the antenna system are held responsible for the relatively poor showing of the effective radius signals of this station in the daytime and under all manner of adverse conditions. Necessarily, there is poor signal field coverage in a southerly direction.

In the reallocation of wavelengths, in the limitation of power, and in any zone reclassification of broadcast stations, the Federal Radio Commission will find the results of these field intensity measurements of invaluable service. In a measure, this radio test car is defining the geographical area of different stations, studying the effects of variations in power, variations in wavelengths,

and determining the causes for signals radiating with greater strength in one direction than in another. Secretary of Commerce Hoover does not overestimate the worth of this work when he places the following valuation upon it:

"Our experience during the year has somewhat more clearly defined the geographical area within which a single broadcast station can give complete service. And 'by complete

service area' I mean the territory within which the average set can depend upon getting clear, understandable and enjoyable service from the station day or night, summer or winter. I do not include radio golf around the edge of these areas in our conception of public service—that game is an exercise of skill and the efficiency of your set plus a gamble on the radio weather. Actual operation of high-powered stations has proven advantageous in broadening the 'complete service area,' but this area is much more limited than many expected. Subjected to the test of positive and reliable service at all times and all weathers it will be found that the real effectiveness of a station falls within a comparatively small zone.

'For some reason or other, the area is not always a circle, as you know, and it varies in different parts of the country for the same power. The Department of Commerce is undertaking the important task of determining these service areas. I am in hopes that we can secure the resources this year to continue the study further. It will give us information on which to base more efficient allocation of wavelengths. In any event, it is obvious that, barring revolutionary discoveries, it is certain that the country must continue to be served by local stations.'

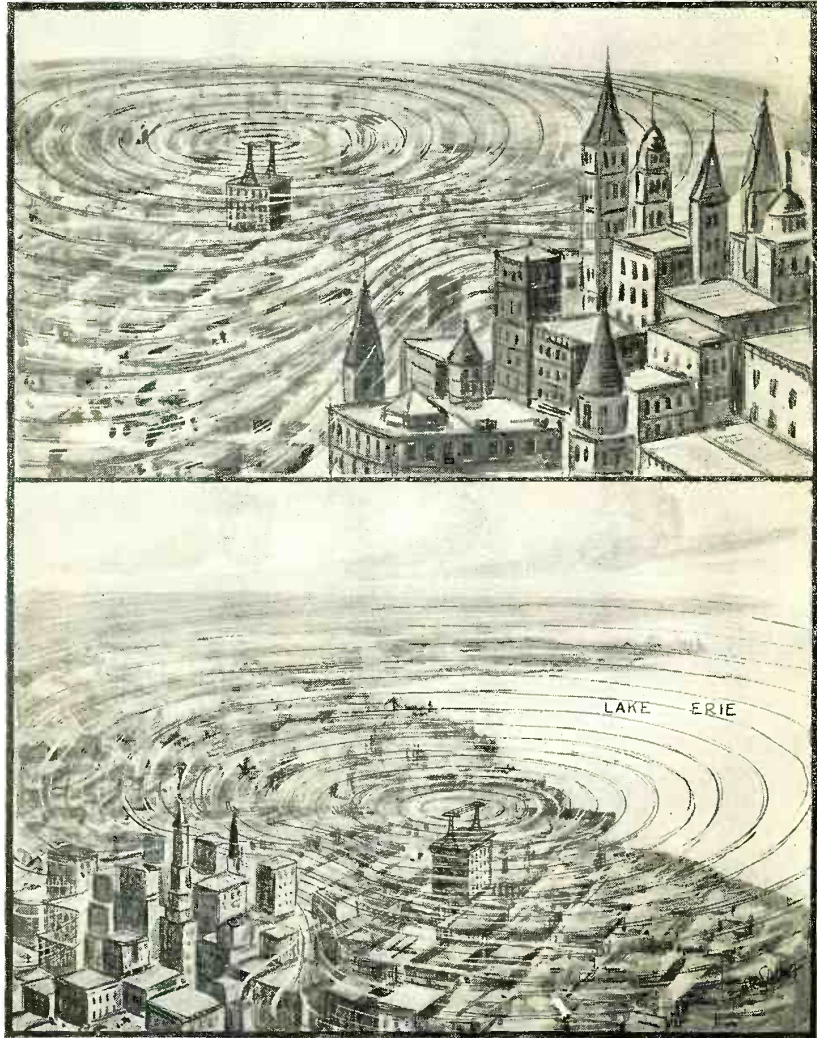

This illustration is an endeavor to present the appearance of the radio waves as they would seem if they were visible to the eye. The great steel buildings turn them aside, as cliffs do sea waves, so that reception beyond these is greatly enfeebled. This is one of the reasons why the tendency to locate transmitters in the open country is growing rapidly; the other being the "shocking" effect of high-power signals on nearby receivers.

Radio News of the Month Illustrated

By GEORGE WALL



Recent tests at Cornell University indicate the possibility of timing races, to 1/2000th of a second, by means of a radio device, the results being preserved in permanent form. The small metal badge worn by the runner causes a deviation in the balanced oscillating circuit as he passes; this causes a deflection of the spot of light in a galvanometer, on which a camera with a moving sensitized film is focused; the passage of the runner is thus indicated, with his exact time. It is the invention of an English scientist, Prof. A. V. Hill.

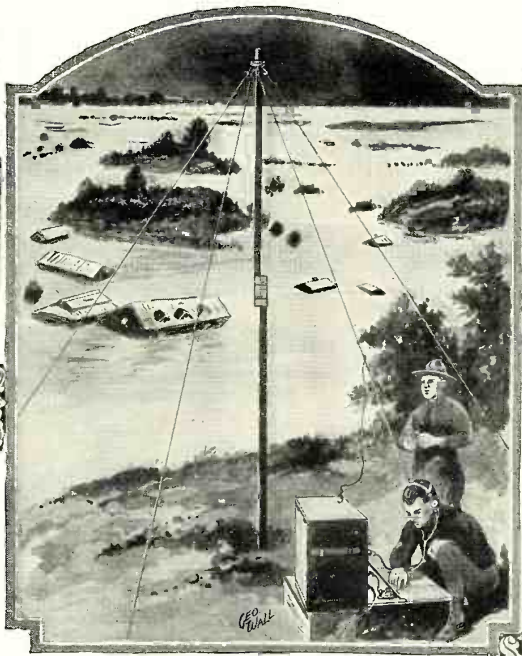

Dispatches from London indicate that penny-in-the-slot radio is to be commercialized, having been authorized by the postmaster-general, who is the czar of British radio. With what enthusiasm it will be received is to be seen. Presumably only one program will be available, from 2LO.



The famous cafe life of Vienna found the attraction of the radio a vigorous competitor, and the enterprising proprietors of resorts decided to capture the enemy's position. The experiment of installing headphones at each table was so successful that the restaurateurs are petitioning for bigger and better programs.

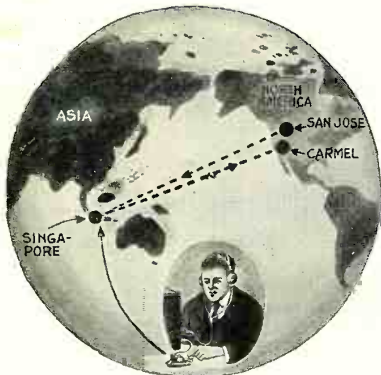

The ultra-short waves used in amateur communication are temperamental; for a signal from a low-power transmitter heard half-way round the earth may be impossible to detect a few miles away. A striking example of this was given recently, when a "ham" at San Jose, Calif., found it easiest to communicate with a friend at Carmel, fifty miles away, by sending his call through an amateur in Singapore, on the Malay peninsula in Southeastern Asia. The message and answer covered 32,000 miles in four laps.

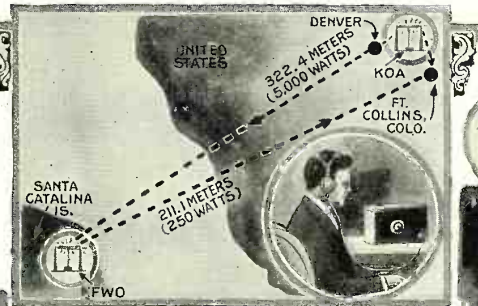

A Fort Collins, Colo., DX listener, J. Thomas Scott, hears his nearest station, KOA, over an 1800-mile path with a two-tube set, by getting the short-wave rebroadcasts from KFWO in California. An interesting experiment for the owner of two sets would be to compare a rebroadcast with the original program for the time difference.

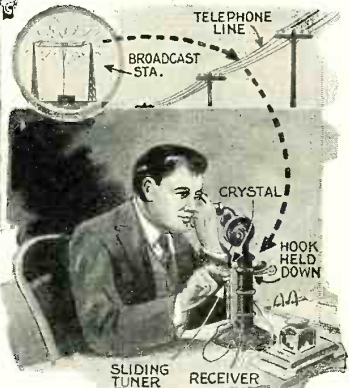

A radio addition to the telephone has been invented by a Washington fan; it utilizes the usual receiver as a headphone for a simple crystal set, which is tapped in to the receiver cord. The tuner is a coil wound on a tube which is clamped to the transmitter standard; and a clamp holds down the hook when the receiver is being used for radio purposes; the telephone wires provide the aerial. A very small tube set may also be used; however, the apparatus has not been approved by the telephone companies.

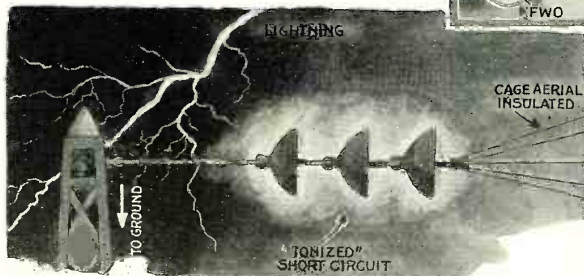

Lightning can interfere with a radio program, not only as static, but also as a short circuit, as shown by a recent experience at the great Bound Brook, N. J., station, WJZ. The aerial is insulated from its supporting towers; but the lightning playing around the latter "ionizes" the air, making it conductive; and the result is a momentary short-circuit to ground, like the closing of a switch, shutting off the transmission until the effect ceases.





The Fly in the Ointment

Presenting the Case of Those Who Entertain the Radio Audience---Gratis

By NELLIE BARNARD PARKER



IN a dance hall of early western days there was tacked above the one-piece orchestra a placard which read, "Don't shoot the fiddler; he is doing the best he can." That kindly and thoughtful request should be snapped up to date by changing "fiddler" to "announcer," and hung over every radio receiver.

There should be etiquette of the air; and the fact that you can't see your host is no excuse for being rude or unkind or thoughtless and sending in messages designed to prick the bouncing bubble of joy at the radio station. People sit before their expensive radio or with their ears neatly pinned back with crystal-set earmuffs, and pose as super-critics of the air; overlooking the fact that at last they are getting something for nothing and, if the gift horse hasn't the proper number of teeth, the dentistry hasn't reduced their bank roll or caused them one ache. Back of the mechanical apparatus which sends forth every kind of a wave but a "permanent," there are human beings—red-blooded men who are endeavoring to give you pleasure; and they are just human enough to appreciate at least the ABCs of courtesy when they give you "play by play, blow by blow or note by note."

Grand opera was recently broadcast over KFI, Los Angeles and KPO, San Francisco through the courtesy of a certain petroleum corporation. It cost many shekels to play host at this musical feast and everyone connected with the effort was pleasantly aglow with justified pride and hospitality, and purring like cats before the fire-place as appreciative telegrams poured into the station. The announcer, in the fullness of

joy, read between acts several of these, which were positively thrilling.

For instance: a ship 700 miles at sea sent word that grand opera was thrilling all on board; a lonely aviator, 5,000 feet in the air, caught the strains of *La Traviata* as he droned through the night; from 1,000 feet below the ground in the damp recesses of a mine, came word that the miners were swinging wicked picks to Alfred's *We'll Drink to the Beauty*; on battleships at San Pedro the sailors' hornpipe was stilled and grand opera occupied the center of the ear-drum; hospital patients wired grateful messages; convicts at lonely mountain road camps sent an appreciative message; from a northwestern sheep camp, eleven sheep herders sent word that the opera blended beautifully with the bleating of thousands of sheep and the howl of coyotes, who, disturbed by the unusual music, pointed their noses towards the moon and sung high, staccato notes with all the ease and feeling of a prima donna.

TAKING THE JOY OUT

Oh, it was a glorious night and the announcer read telegrams from high and low, fat and thin, young and old and "her" and "him." Some praised the sponsors and their product, and the announcer gave credit where credit was due. And then, right out of the sky, came the fly in the ointment! A man wired in: "We are enjoying the program but can't the announcer be choked off and let us have opera without telegrams and advertising?" And pretty soon another "guest" wired his objections against being "sprayed with petroleum" while he listened. Clever, yes, but it struck one lis-

tener at least that, when a company has spent thousands of dollars to broadcast a program, it has bought the right to let you know who your host is and what it has to sell.

Most programs are paid for by some concern which gives you great slabs of delicious cake put together with a very thin spread of its product, whether it be sleepy-time mattresses, chewing gum, never-run hosiery or petroleum. If you were dining out and your host's pet story bored you and you weren't interested in his account of what a good product he handled, you wouldn't tell him to close the muffler and pass the chicken. That isn't done by people who know their *I-thank yous* and *Beg-your-pardons*. Yet the men who broadcast these programs are just as surely your hosts as if you sat at their tables—with this difference: if you don't like their stuff you turn a dial and cease to be a guest and your abrupt departure leaves no aching void. You are free to steer your airship where you please, casting out your line selectively, knowing there are just as good tunes on the air as ever were caught. Such being the case, why send in thoughtless messages to mar the perfect pleasure of your host? Let him sing his little solo without having the anvil chorus crab the act!

THE ANNOUNCER'S PART

It is the business of the announcer to hold an unseen audience which possesses tastes and intellects—if any—that run the gamut from the original protoplast to Mencken. He mentally hops around like pop-corn in a popper and sometimes his

(Continued on page 75)

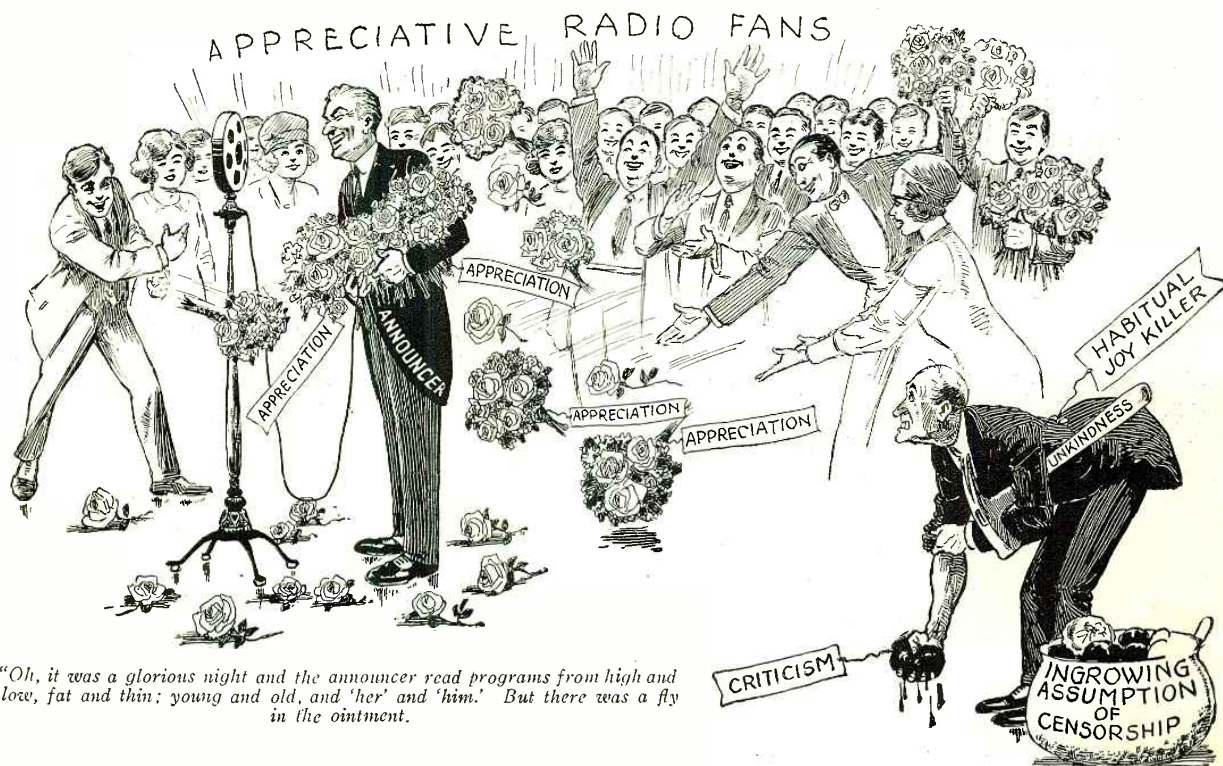

"Oh, it was a glorious night and the announcer read programs from high and low, fat and thin; young and old, and 'her' and 'him.' But there was a fly in the ointment."



What's New in Radio



VENTILATED RHEOSTAT HAS BUILT-IN SWITCH

A NEW combination filament rheostat and switch, of simple but excellent construction, has been brought out by a well-known parts manufacturer. It is of the one-hole mounting type, and can be obtained in the standard rheostat resistance-ranges.

The frame F of the instrument is a single piece of molded bakelite, formed in such a manner that the resistance-wire strip W rests on a series of thin ribs which give the frame the appearance of an ordinary gear. This construction allows plenty of air to circulate under the resistance-wire strip, as well as over the exposed outer surface, so that the possibility of abnormal overheating and possible burn-out is to a great extent overcome.

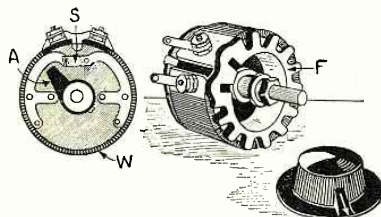

Left: end view of the rheostat, showing the switch. Right: general view of the instrument.

Illustration courtesy Herbert H. Frost, Inc.

The switch portion of this rheostat is built upon the back of the frame. A separate thin disc of bakelite holds two arch-shaped springs S, whose ends close together at the spot to which the letter S on the accompanying drawing points. A small bakelite arm A is fastened by means of a collar and set-screw to the end of the rheostat shaft, in such a way that, when the contact arm is entirely off the resistance wire at the "off" position, the bakelite arm spreads the contact springs apart and thereby opens the circuit in which the latter are connected. The operation is simple and positive.

POWER-AMPLIFIER UNIT HELPS WEAK RADIO SETS

RADIO set owners, who are not fully satisfied with the volume they are obtaining, will find in a new power amplifying unit a satisfactory and inexpensive means of increasing the output of their loud speakers. This unit is connected simply to the pres-

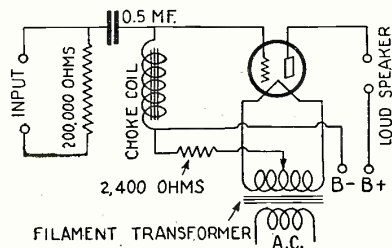

Hook-up of the power-amplifier unit.

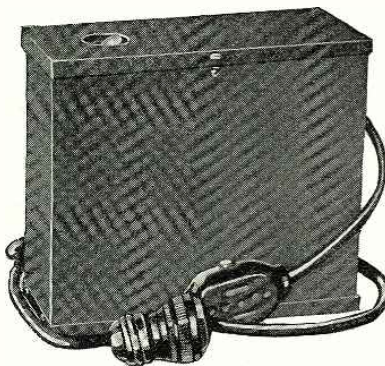

General view of the power amplifier in its case. Illustration courtesy Acme Apparatus Co.

ent loud-speaker terminals of the receiver, and acts as an additional stage of audio-frequency amplification. It uses a single power tube, of either the 112 or 171 type, which obtains its filament current directly from a transformer contained in the unit and working off the 110-volt, 60-cycle A.C. house line. The "B" voltage must be supplied by an external source; the existing "B" batteries or "B" socket-power unit may be used if the voltage is sufficiently high for the particular amplifier tube selected for the unit. Electrically, the power amplifier consists

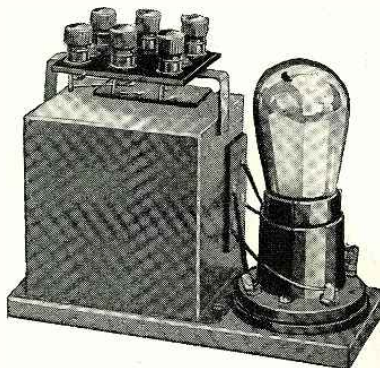

The components of the amplifier are sealed in the case at the left of the tube socket.

of a single stage of resistance-capacity coupled amplification, with a high-impedance grid choke. Grid-bias voltage is furnished automatically, no external "C" batteries being necessary. The highly advantageous characteristics of the resistance-coupled amplifier need no exposition here.

The filament-lighting transformer, grid-coupling condenser and the two fixed resistors are contained within a sealed case, from which connecting wires lead to six binding posts on a little insulated sub-panel above it. This case and the tube socket are mounted on a wood base, the entire assembly fitting in a neat metal box 6 3/4 x 6 x 3 inches over all. The top of this box is removable.

A flexible cord, fitted with a standard attachment plug and a switch, is provided for connecting the unit to the lamp socket.

FIXED CONDENSER IS MOLDED IN BAKELITE

A NEW fixed condenser, using mica as the dielectric, is molded in solid bakelite. The capacity of the actual condenser unit is determined by test and the elements are impregnated with sealing compound before the bakelite case is molded around it. The rated capacity of the completed condenser can thus be kept within the limit of 10 per cent. variation claimed for it; units which test outside this limit being rejected before they are permanently enclosed in the bakelite.

The D.C. resistance across the terminals ranges from 2,500 to 5,000 megohms at 650 volts D.C., according to tests made by the manufacturers. These values correspond to

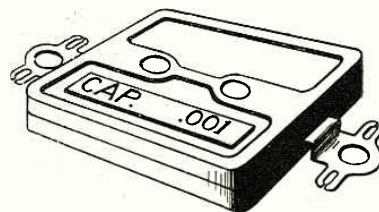

The new molded-bakelite fixed condenser. Illustration courtesy Aerovox Wireless Corp.

practically infinite resistance. The device is available in all the standard capacities.

The mounting lugs of the condenser have split "ears," which can be bent back easily to allow the ends of stranded wire to be twisted securely around them. The confinement of these strands prevents them from touching other parts of a set and causing possible short circuits.

CONNECTOR ALLOWS USE OF POWER AMPLIFIER TUBE

IN many of the radio sets manufactured a year or more ago present-day amplifier tubes of the power type cannot be used unless changes are made in the battery wiring. Owners of such sets who lack either the inclination or the ability to perform the rewiring operation, but who want to use power tubes, will find in a new power-tube-connector, recently placed on the market, a cheap and simple solution of their problem.

The connector consists simply of a plug made exactly like the base of a tube and a separate tube socket, together with several flexible wires that connect the plug to the socket and permit the attachment of leads for the extra "B" and "C" voltages

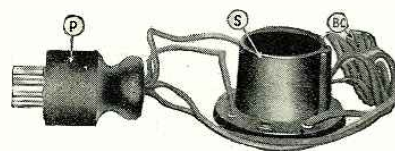

P, plug which fits in the final A.F. socket in the set; S, socket for power tube; BC, wires for additional batteries.

Illustration courtesy Alden Mfg. Co.

required by power tubes. The plug is inserted in the last amplifier socket and the power tube is then placed in the receptacle; nothing in the set itself is disturbed. The wires are long enough to permit the additional socket to be mounted conveniently inside the receiver.

PORTABLE RECEIVER WEIGHS ONLY 25 POUNDS

ONE of the lightest, and most truly portable, "portable" radio receivers that has ever come into the RADIO NEWS Laboratories is that illustrated on this page. Packed for carrying, the whole outfit is 12½ inches long, 10 inches high and 8½ inches deep; and, complete with tubes, batteries and loud speaker, it weighs only twenty-four pounds. It is smaller than an ordinary handbag, and can be handled just as easily as that article on trips.

Practically every available cubic inch of space in the little containing box is occupied by a piece of radio apparatus. The front of the case, which is completely removable, acts as a frame for the wires of the aerial, which is of the loop type; the

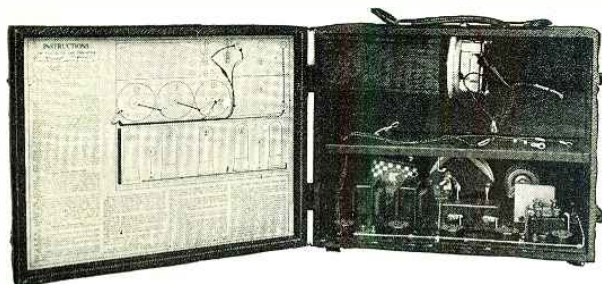

four cleats shown in the corners of the front (in the view of the set erected for operation) hold the turns of wire in place and prevent them from fouling the instruments on the tuning panel.

The latter occupies the lower section of the set's front, and holds a variable condenser for tuning, a rheostat, a potentiometer, a battery switch, and a phone jack. The condenser dial is fitted with a friction "vernier" for fine tuning. Directly above the dial are two tip jacks, which accommodate the flexible wires connected to the ends of the loop aerial. When the set is folded up, these wires are fastened in two little catches on the inside of the set front.

The top section of the case is devoted to a condensed loud-speaker tone chamber, spreading into a rectangular opening in the front, which is covered by a protective grillwork. The loud-speaker unit is located just beneath the carrying strap on the top of the cabinet.

Three standard No. 6 dry cells and two 22½-volt "B" battery blocks are required to operate the five 199-type tubes in the receiver. These slide into place horizontally on a shelf located midway between the top and bottom of the case. The radio instruments proper are beneath this shelf, resting on an insulated sub-panel. The back of the case is hinged, and can be swung open to reveal the "works" of the set.

The complete circuit diagram of this portable receiver is given herewith, showing that the first three tubes (the third being the detector) are arranged in a combination tuned and untuned R.F. circuit, the last two acting as straight audio-frequency amplifiers. The grid circuit of the first tube, which includes the loop aerial, is tuned by the variable condenser C, this stage being stabilized by the potentiometer P; the latter is represented on the panel by a knob marked "volume control."

The coupling devices between the first

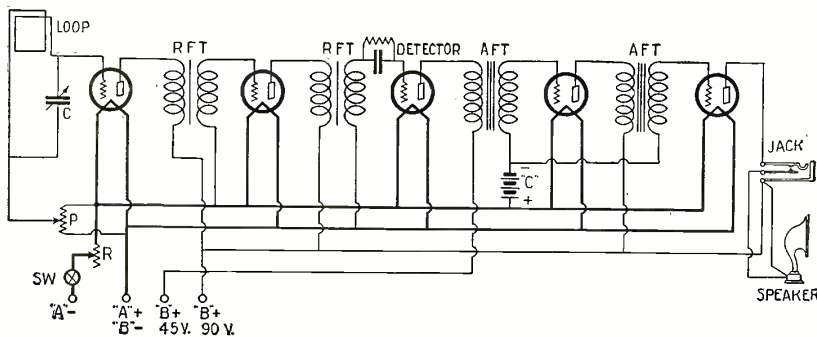

Schematic wiring diagram of the five-tube portable receiver. With the phone jack empty, the loud speaker delivers the full output of the set.

and second, and the second and third tubes are fixed radio-frequency transformers, marked RFT. The audio system is of conventional design; the transformers are indicated as AFT. A "C" battery is used in the usual position. The jack in the last stage allows the use of phones, if desired. Normally, when it is empty, the speaker

is parable to that of the high-priced talking machines of the new and improved type. The only limiting factor is the actual quality of the audio amplifier and the loud speaker of the radio set. With any good outfit the reproduction afforded by the system is a revelation of clarity and fidelity to the phonograph-owner who has grown accustomed to the normal output of the machine.

The attachment will be found useful also by radio set owners who want to play phonograph records occasionally, but do not desire to buy an expensive machine to gratify their desires. They can simply purchase an inexpensive turntable (with or without a regular phonograph horn) and then use the "recreator" as the permanent pick-up, to operate through the radio set and its loud speaker in the manner outlined here. The change from radio to phonograph-record reproduction is very quickly made and requires no skill.

The "recreator" consists of three principal parts (see illustration): an electromagnetic generator or "pick-up" PU which carries a needle in the same manner as the regular phonograph tone-arm, and is fastened to a swinging arm and a supporting base; a volume control V, the adjustment of which provides smooth graduation of the musical output's intensity from full volume to absolute silence; and a special plug P, which fits in the detector-tube socket of the radio receiver.

The device is easily installed, and in-

The "A" and "B" batteries rest on the shelf which runs through the center of the case. The loud-speaker unit is the white object just below the carrying strap.

is directly connected to the full output of the receiver.

The rheostat R controls the current to the filaments of all the tubes.

"RECREATOR" MODERNIZES OLD MODEL PHONOGRAPHS

A NEW "recreating" device, which from an ordinary phonograph reproduces music electrically through any radio receiver using a loud speaker, has been recently placed on the market by a New England firm. With its aid an old phonograph of the short-horned variety can be changed into an instrument of a quality fully com-

Right: the portable receiver up all set ready for use. The wires which form the loop aerial are held in place by the four cleats shown in the corners of the upright member. Below: the receiver closed for carrying. No wires can be seen.

Illustrations courtesy Trav-Ler Mfg. Corp.

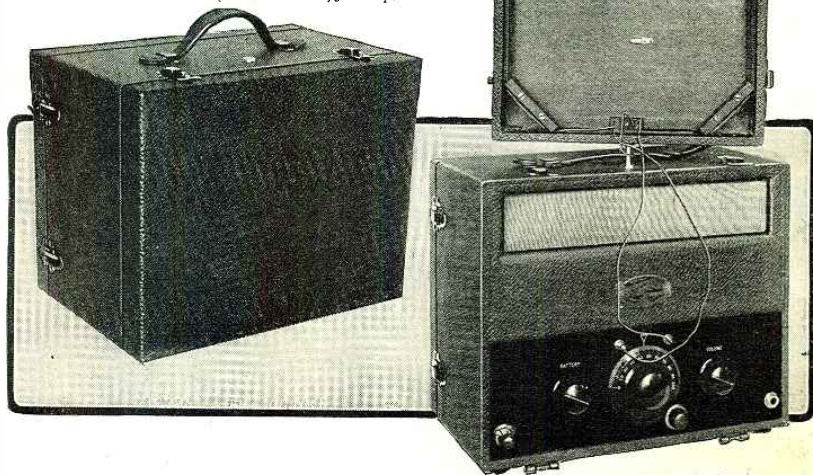

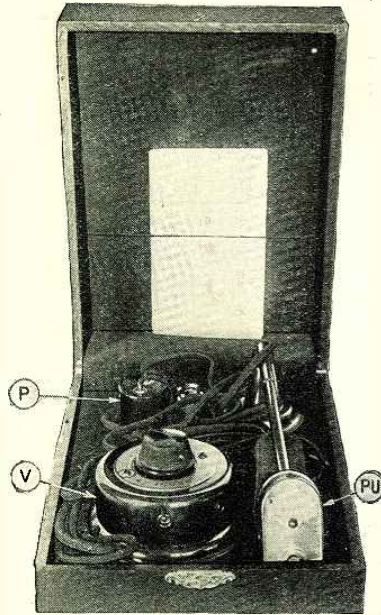

The parts of the "recreator" as they appear in their carrying case. PU, magnetic pick-up; V, volume control; P, plug.

volves no changes in either the phonograph or the radio receiver. The regular tone-arm of the phonograph is simply turned upward and out of the way; then the heavy base carrying the pick-up and its arm is set in a position near the edge of the turn-table so that the pick-up will traverse the record just as the regular tone arm does. The detector tube is removed from the radio set and the special plug P inserted in its place. The set switch is snapped on and the turntable started, the loud speaker will then deliver music.

If desired, the magnetic pick-up unit can be attached permanently to the neck of the phonograph tone-arm, and the additional arm and stand thus obviated. The tone-arm then serves merely as a mechanical support for the pick-up, the existing horn in the phonograph being kept entirely idle.

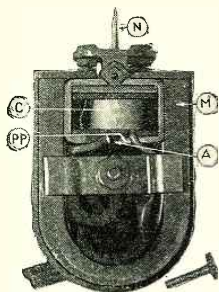

Close-up of the magnetic pick-up, which is connected to the audio amplifier of the radio receiver.

Illustrations courtesy American Bosch Magneto Corp.

A close-up of the pick-up device itself is shown. It consists of a strong permanent magnet M, the magnetic field of which terminates at the small pole-pieces PP. Between the latter is a soft-iron armature A, which runs through the center of the coil C and terminates in the needle-holding mechanism N. This mechanism is hinged just above the upper end of the coil, so that the "wiggling" of the needle in the grooves of the phonograph record causes the armature end A to vibrate accordingly. This movement, varying the magnetic flux of the permanent magnet, results in the generation of a modulated current in the coil

C, which is connected to the audio amplifier of the radio set. This current, carrying the effect of the music on the record, is varying at audio frequencies, and is amplified in the radio set just as if it were a detected radio signal supplied by the detector tube.

The three units of this phonograph attachment are attractively finished in statuary bronze. They are furnished in a neat leather case, which can be slid into a record compartment of the phonograph when the latter is functioning in the usual way.

AUTOMATIC CHARGER RELAYS IN "A" POWER UNIT

IN a new "A" socket-power unit which employs a regular storage battery and a charger, a uniform and dependable source of "A" current is assured by the use of a relay-switch arrangement different from that usually associated with battery-and-charger combinations. Two control switches, one of which is operated by the on-off switch on the front panel of the radio receiver and the other by the battery itself, are so constructed and connected that the former turns on the charger when the set control is in the "off" position, while the latter automatically cuts it off (with the set switch still "off") when it has charged the battery fully. The charger itself, instead of being of the "trickle" type that feeds a fraction of an ampere to the battery whenever the set is idle, is one of two-ampere capacity; so that it is capable of re-energizing in quick order a battery that has been depleted by an extended period of continuous service.

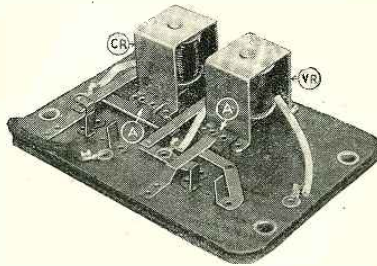

Close-up of the relay switches. CR is in series with one battery lead to the set; VR is directly across the battery; A-A indicate contact armatures.

The first-mentioned relay performs the additional function of turning on the 110-volt alternating current to the "B" power device when the receiver is snapped on. A convenient standard receptacle to accommodate the "B" unit connector plug is provided on the side of the "A" unit case.

The two relays, of which a close-up is shown, are of simple design. The one operated by the set switch consists essentially of an electromagnet with a winding of but a fraction of an ohm resistance, connected directly in series with one of the leads running from the storage battery to the "A" binding posts on the receiver. This

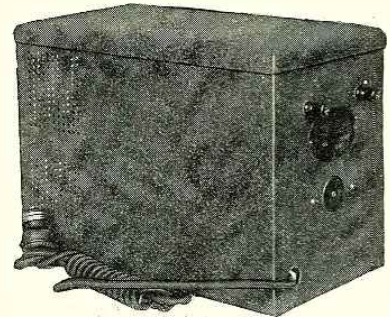

The simplicity of the "A" supply unit is evident from this illustration.

magnet (CR) operates a double-contact switch, the movable blade of which is part of the armature resting near the pole pieces. With the set switch off (and the winding therefore unenergized), the position of the switch is such that the house-lighting A.C. is passed to the charger, which in turn charges the battery. When the set is turned on, the current drawn by the tube filaments passes through the electromagnet, energizes it, and causes it to pick up the contact blade. This movement transfers the A.C. from the charger to the "B" power unit.

The second relay is of almost identical construction mechanically. However, its winding is of comparatively high resistance (about 127 ohms), it is connected without interruption to the battery terminals; its armature switch is a simple S.P.S.T. one. This latter switch is in the A.C. circuit between the first relay switch and the charger transformer. Thus, when the battery has been fully charged and develops its full rated voltage, it energizes the high-resistance electromagnet sufficiently to cause the latter to pick up its armature and thereby to open the charger line. The current consumption is negligible.

The accompanying illustrations show the appearance of the complete "A" socket-power unit. In the inside view T is the charger transformer, S the socket for the rectifier tube, B the battery, and RS the relay switches. These instruments are enclosed in an iron case 12 inches long, 9 inches high and 6½ inches deep, nicely finished in a brownish-red color. The only external fittings are a cord and plug for the alternating current, two output binding posts, and a receptacle for the "B" unit plug.

FOUR MEASURING RANGES IN RADIO SET TESTERS

A RADIO set tester, intended for the special use of the radio service man and the radio dealers, has been developed by a well-known electrical instrument firm. It is a versatile device, and can be used as well by the radio experimenter who is desirous of making accurate current measurements in his ordinary experimental and constructional

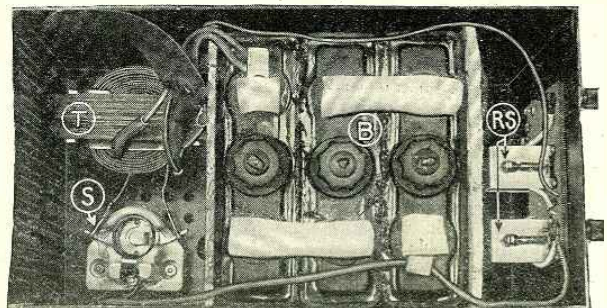

Inside view of the "A" socket-power unit, showing, from left to right, the charger, the storage battery and the relay switches.

Illustrations courtesy the Stewart Battery Co.

work, but cannot afford to invest in three or four separate meters.

This tester measures, both at the battery terminals and at the tube sockets, the various "A," "B" and "C" voltages used in practically any radio receiver. It can be used to determine the continuity of circuits, and to test the D.C. characteristics of the vacuum tubes under the same conditions that exist when the bulbs are in their sockets in the set. In performing these functions it employs the regular batteries or socket-power units ordinarily attached to the receiver; no auxiliary sources of current are required.

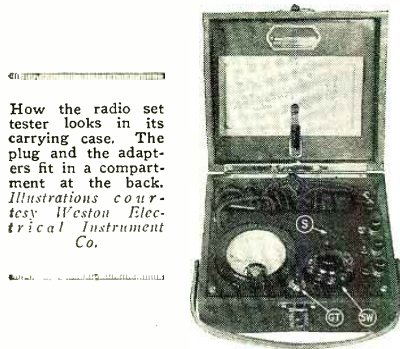

How the radio set tester looks in its carrying case. The plug and the adapters fit in a compartment at the back. Illustrations courtesy Weston Electrical Instrument Co.

The device consists of a single meter, having three voltage-ranges of 300, 80 and 8 volts, and a single current-range of 20 milliamperes; this is mounted in a sturdy wood carrying case along with a rotary switch, a tube socket and a test plug for connection to the radio receiver proper. The meter is made to act in its four different capacities by means of the switch SW. In one position, the switch connects the meter direct to the three binding posts on the right-side of the panel; the instrument is then an ordinary double-range voltmeter, and with the aid of two flexible test cords which are fastened to the binding posts, may be used for all the purposes for which a straight voltmeter is required.

The voltage ranges have a resistance of 1,000 ohms per volt, which means that full-scale deflection is produced with a current of only one milliampere. This high resistance makes the test set suitable for reading the voltages of "B" socket-power units, a purpose for which ordinary meters are worthless.

When a tube is to be tested, it is removed from the receiver, placed in the receptacle S on the panel of the tester, and the plug P inserted in the socket in the receiver. The adapters D1 and D2 permit the testing of tubes with the old-style UV bases.

As the switch knob is turned, the meter will indicate plate voltage, plate current,

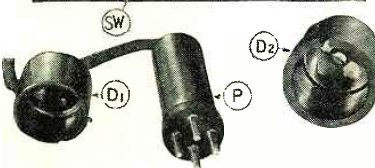
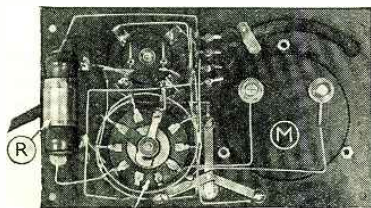

Back view of the meter panel: M. meter; SW, changeover switch; R, protective resistor. Below: P, plug; D1, D2, adapters.

filament voltage and grid-bias voltage, respectively. Defects in either the plate, filament or grid circuit are immediately evident on the meter. The condition of the tube under test as an amplifier may be determined roughly by means of the little switch GT, which throws the "C" battery (or other means of bias) in or out of the circuit.

The complete tester weighs three pounds. It is exceptionally well built, and seems fully capable of withstanding the strain of portable service.

UNUSUAL CONSTRUCTION MARKS NINE-TUBE RECEIVER

THE nine-tube receiver shown in the two accompanying illustrations is one of the most spectacular commercial sets in existence. It is made of smooth, natural-finish aluminum; the entire containing cabinet, as well as the individual shields between the R.F. amplifier compartments, being of this metal. The front-panel fit-

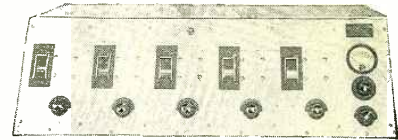

Front-panel view of the nine-tube receiver. The case is made entirely of aluminum. Illustrations courtesy Golden-Leitz, Inc.

when all five condensers are coupled together to turn as one.

The R.F. transformers are of the plug-in type. With the correct coils, the receiver will tune from 35 meters all the way up to 3,600 meters. Either a regular outside aerial or an indoor loop may be used, as conditions require. Provisions are made for the connection of either.

The components of each R.F. amplifier stage are enclosed in a completely shielded compartment, most of which is formed by the front, bottom, back and top of the all-

Inside view of the set. The R.F. transformers are removable. The compartment on the right houses the audio amplifier. Note the shields between the R.F. sections.

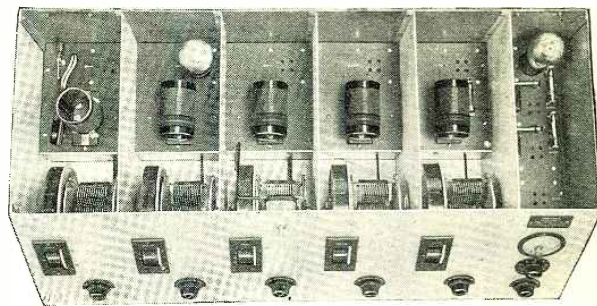

tings are finished in black, this color contrasting markedly against the light gray of the aluminum.

Electrically, this set represents some of the most advanced ideas in broadcast receiver design. Its circuit incorporates four stages of tuned radio-frequency amplification, fully shielded, a non-regenerative detector, and four stages of audio amplification. Of the latter, the first (following the detector) is transformer-coupled, the next two resistance-capacity-coupled, and the fourth transformer-coupled. The heavy output of this system is fed to the loud-

speaker through a filter consisting of a large choke coil and a fixed condenser.

The actual circuit of this nine-tube receiver is shown. It is not recommended that the radio fan try this hook-up merely as an experiment; for, unless the special methods applied to the factory product are duplicated, the system will be uncontrollable.

The set overall is 27 inches long, 8½ high and 13 deep. The front panel is in-

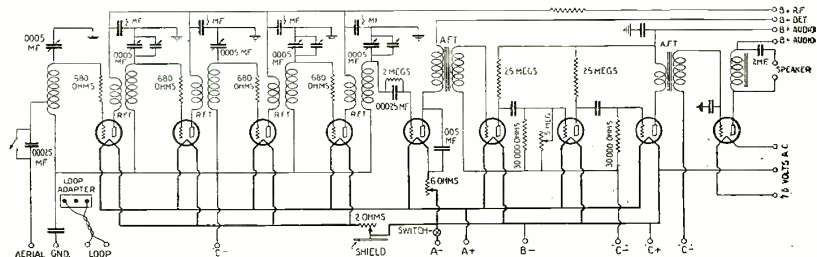

Hook-up of the nine-tube receiver. Four stages of tuned R.F. and four stages of A. F. are used.

speaker through a filter consisting of a large choke coil and a fixed condenser.

The five variable condensers which tune the R. F. circuits are mounted in a line parallel to the front panel. Each is fitted with an individual dial of the vertical type, but they may be grouped together, or "ganged," to simplify the tuning operation. Small couplings between the condensers are simply tightened down with a screwdriver to accomplish this "ganging" in any desired combination. Small "vernier" or midget condensers are connected across the second, fourth and fifth main condensers to allow compensation of these respective instruments

clined about ten degrees from the perpendicular, so that the operator may rest his hands on the dials comfortably while tuning. This panel holds, in addition to the condenser dials, six small knobs for the various rheostats and compensating condensers, and another for switching the panel meter to various positions in the circuit to read the "A," "B" and "C" voltages.

For this receiver the manufacturer makes also a special "B" socket-power unit capable of supplying the heavy current demanded by the nine tubes. This unit is housed in an aluminum case, which matches that of the set proper.

\$250 PRIZE CONTEST

What Is the Best Title You Can Suggest for Our Cover Illustration?

If you are an alert (?) reader, you will have noticed that every month we have a picture adorning the front cover of RADIO NEWS. If you have been still more alert,—in other words, if you belong in the Sherlock Holmes class—you cannot have failed to notice that for every other month we have a so-called "human interest" picture, while in alternate months there is a technical picture on our front cover. True—Very true.

There is, of course, no good and sufficient reason for this beautiful arrangement at all, except that we have been doing it for many years, and evidently are afraid, now, to change. Why there should be a picture on the front cover, at all, we ourselves have never understood, and probably never will. One of these days a smart and courageous editor will start the fad of printing nothing but the title of the publication, leaving blank the rest of the page; whereby the children may have an opportunity to do a little scribbling, or whereon you can write down telephone numbers, or draw radio hook-ups. So far, we admit we haven't had the courage to try such a revolutionary improvement; but, if you say the word, we'll try and do it.

THE EDITORIAL WOES

In the meanwhile, every month there is a grand battle in the editorial offices, as to what or what not is to adorn the cover. Usually a number of editors, artists, and others, are grouped about the table, all perspiring profusely and trying to hatch out a good idea. Sometimes there must be a compromise, because one group will insist on this, and the other group will insist on that; so that, if the group is evenly divided, the RADIO NEWS Cover Illustration Committee will naturally come to loggerheads. This was the case last month, when one group suggested that the reformed safecracker should have a radio set all of his own, one that would make him feel at home. The other group, with equal votes, wanted to show a young man in the act of "borrowing" something from dad's radio set—both good suggestions, and both worthy of a cover illustration. Each group thought its idea best, and would not budge one kilocycle. The spokesmen for each group had such good arguments that it was impossible to get them together; and so things stood when the time limit, 5 o'clock of the afternoon, drew close, and the artist really had to start to submit his sketches.

A HAPPY THOUGHT!

At this juncture, by one of those lucky incidents that sometimes will break even in an overworked editorial office, who should come marching in but Fips, Chief Office Boy? He was immediately appointed as an arbitrator, to bring the two warring factions together; and, with his usual deep insight into affairs human, as well as inhuman, he took his verbal sword and delivered an Alexandrian verdict, by cutting the Gordian Knot in two. His verdict was that, as long

THE old-fashioned stereoscope, which adorned so many front parlors during the Mauve Decade, gave perspective to photographs by imposing on the eyes simultaneously separate pictures taken with two cameras spread apart. One well-known pair of photographs showed the moon's disk as an obvious hemisphere; the views correspond-

\$250 PRIZE CONTEST Cash Prizes

First Prize	\$75.00
Second Prize	50.00
Third Prize	35.00
Fourth Prize	25.00
Fifth Prize	15.00
Sixth Prize	10.00
7th, 8th, 9th, 10th Prizes at \$7.50 each	30.00
11th and 12th Prizes at \$5 each	10.00
	\$250.00

as the two warring factions could not possibly get together, the two should combine, and that the two ideas should be harmonized into a single cover.

Needless to say, the Committee voted enthusiastically for the idea, and finished it by embracing dear Fips. A resolution was also drawn, to prevail upon the powers that be, that he should get at least 50 cents increase in his weekly salary.

So there you are, and here is the compro-

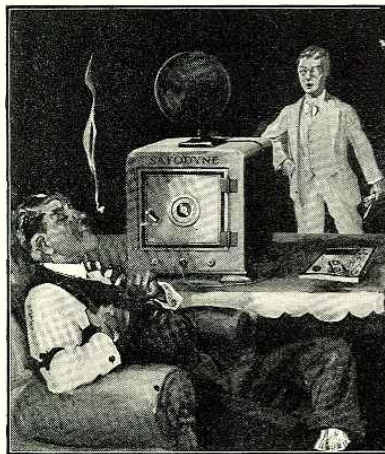

What title can you suggest for the above portrait of a "gent" and his son and heir, both keenly interested in radio?

mise cover. We might state that when Fips was asked what the title for the illustration should be, he suddenly vanished by crawling underneath a desk and out of sight. The Committee, tired out, attempted for a few minutes to solve the puzzle, but finally gave it up as a bad job. So it was decided, as usual, to put the burden upon the readers and "let George do it." Anyhow, the Committee said it would be worth \$250.00 to find out what kind of a title could possibly

"STEREOPHONIC" HEARING

ing to those from cameras thousands of miles apart.

A corresponding feat in producing "stereophonic" hearing has been again demonstrated by Capt. Rounds, a British radio engineer, who placed microphones on opposite sides of a stage during a program; each mike led to a separate amplifier, and each

be suggested. They also thought that the prize would be cheap under the circumstances.

IT'S UP TO YOU!

Now, then, since you have been let into the secrets of the inner conclave, it is up to you to take your paper and pencil and figure out what the cover is all about, and what it stands for. That is all there is to it. Just study the picture carefully and see what it can suggest to you—and don't forget that this is a radio magazine, and the title really must have something to do with radio. The cleverer the title is, the better your chances will be to win the first prize.

Of course the Committee suggested a few names, such as "Safety First", "Safe at Last", "A Safe Radio", and similar titles; which, however, were thought to be too obvious and not so good nor clever enough.

Of course we know that our readers can do much better, but please do not jump to conclusions about the nature of the contest. *Read the rules carefully*, to make sure that your entry, whatever it is, will not be disqualified for lack of compliance with them.

CONDITIONS AND RULES OF THE \$250 COVER PRIZE CONTEST

- (1) No title may contain more than 10 words.
- (2) Contestants may submit as many titles as they care to. There is no limit to the number.
- (3) Every title must be clearly typewritten or printed with a pen, (not written in longhand), on a separate sheet of paper (or card). Not more than one title is to be written on each sheet of paper, or each card.
- (4) Each sheet of paper or card must bear the name and address of the contestant submitting the entry; which name and address should be typed or printed on the same page. No other matter should be included. Do not write on the reverse side of the sheet.
- (5) Pencil matter must not be entered in this contest.
- (6) All entries must be submitted on flat sheets of paper or cards, of such size that it is not necessary to fold them into the envelope. No folders or rolled heavy paper will be admitted to the contest; a government postal card, however, may be used if desired, instead of enclosing the entry in an envelope.
- (7) Any one is eligible to enter this contest, with the exception of employees of the Experimenter Publishing Company and their relatives.
- (8) This contest closes August 20, 1927, at noon; by which time all entries must have been received at this office. Announcement of the prize winners will be made in the November, 1927, issue of RADIO NEWS, upon the publication of which the prizes will be awarded.
- (9) Do not enclose the entries with any other communications to the Editorial or other departments of the Experimenter Publishing Company. This may result in the delay or loss of one, or both.
- (10) The editors can not send individual acknowledgments of entries, or enter into correspondence regarding them or the terms of the contest, which are given plainly here. Entries can not be returned to the senders.
- (11) The prizes of this contest will be awarded to those submitting, in the opinion of the judges, the cleverest titles.
- (12) The judges of this contest will be a board composed of the Editors of RADIO NEWS, whose findings will be final.
- (13) Should two or more persons submit the identical title considered best, second best, etc., each will be awarded the prize tied for.
- (14) Address all entries to Editor, Cover Title Contest, RADIO NEWS, 230 Fifth Avenue, New York City.

amplifier to a separate earphone on the head of each listener. The sense of direction of the audience was marvelously magnified as to sounds between their "electric ears."

While using this principle in broadcasting would require two receivers, and two carrier waves, or a double modulation of one, it suggests very interesting possibilities.

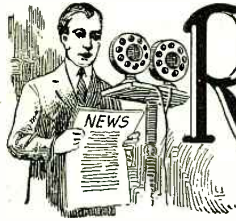

Radio News of the Month



REACHING LIMIT OF DX?

CONFIRMATION of reception of 2LO, London, on Christmas Eve last, with a single-tube regenerative set, has been obtained by G. J. Williams of Camberwell, Melbourne, Australia. This distance is 12,000 miles, and accomplished in the Australian midsummer, at 10 p. m., when it was about noon of the same day in London.

—Arthur R. Goode.

Short-wave experience suggests that signals increase in intensity as the antipodes are approached, where waves converge from several paths. For this reason, points exactly opposite would constitute a radio "whispering gallery."

ANTI-BLOOPER ORDINANCE

MINNEAPOLIS has led the way to elimination of a radio nuisance by an ordinance providing imprisonment, or a fine of not more than \$100 nor less than \$15, for the operation of a receiver which radiates in such a manner as to cause interference. The operation of any electrical apparatus, such as battery chargers, which may cause interference, is forbidden from 6 p. m. until midnight.

DUTCH SHORT-WAVE BROADCASTS

SEVERAL readers of RADIO NEWS have reported hearing experimental programs which they took to be from Holland, on very short waves. This would appear to be FCJJ, the experimental station of the N. V. Philips Radio Co., at Eindhoven, Holland. Transmissions of this station on 30.2 meters were recently rebroadcast by 2BL, Sydney, Australia.

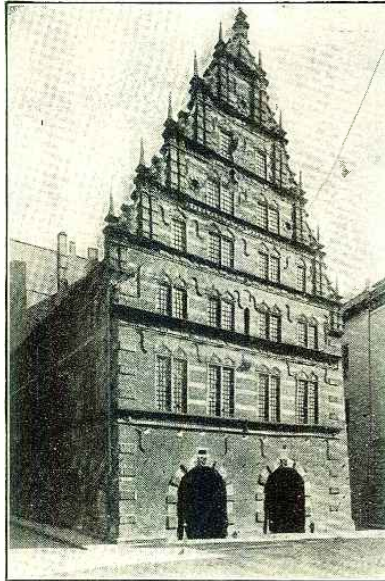

OLDEST BROADCAST STATION

THIS venerable pile, the Alte Stadwage, or Old Weighhouse of Bremen, Germany, will be the future home of the city's broadcast transmitter, studios and manager's residence. Riveted with iron clamps into its facade is the date of its erection, 1587. The adaptation to modern scientific needs will not be allowed to mar its architecture, which is a mixture of Gothic and Renaissance. The station, operated by the Nordische Rundfunk Gesellschaft, relays Hamburg with 700 watts power on 400 meters, at the present time.—Frank A. Gibson.

(Continued on page 87)

SENDING WITHOUT AERIALS ON SHORT WAVES

THE U. S. Navy announces two-way short-wave communication between NKF, Washington, and 4XE, Winter Park, Florida, without the use of an aerial on either transmitter, the helical inductances of the antenna circuits alone being used. The distance covered is about 900 miles; the frequency used was 13,940 kc., or 21.51 meters. Very little difference in the signal strength was observed when the transmitting aerials were discontinued. While this feat has been performed before, it is believed that the distance covered sets a record.

DOMINION JUBILEE BY RADIO

CANADA'S sixtieth birthday will be observed on July 1 with broadcasting along an international chain, extended to both sides of the Atlantic. The chimes at Ottawa and a message by King George V will be carried over British and Dominion land-lines linked by the transatlantic beam. They will be heard as well on the Continent of Europe and in the United States.

RADIO CONTROL DEMONSTRATION

SENATORS and members of the chamber of the Japanese parliament were official guests March 13 of the successful demonstration of the radio "telemechanic," the invention of Captain Nagayama, of the army, at Toyamahara, Tokyo. This device was shown to be capable of distant control of an automobile, airplane or ship by radio waves.

—T. Yamada.

A Prediction—and Its Fulfillment

EDITORIAL—"RADIO TELEVISION," By Hugo Gernsback
(From RADIO NEWS, May, 1926.)

Through the future application of Television, it is quite logical that while a station is broadcasting a song, you will be able to see the face of the singer at the same time, through a transmission on the same wave to which you are tuned in, for the following simple reason.

The range of acoustical frequencies is really very narrow, and does not take in a wide band; the human ear responds to no vibrations above a frequency of 23,000 per second. That is the reason why the so-called radio "carrier" is inaudible. To the non-technical reader it may be explained that the "carrier" is the fundamental wave emitted by a broadcast station, which is on the air at all times when the station is transmitting. When no one is speaking or singing at the broadcast studio, you hear nothing but a faint rushing sound in your receiving instrument. The vibrations of this carrier run into millions per second, and that is why we cannot hear them directly.

If, however, Television is perfected (as it almost surely will be during the next two years, or perhaps sooner) it will be possible to impress the Television impulses upon this same "carrier" which brings the sound impulses to your set. The Television impulses, being of a frequency too high to be audible, will not interfere with your loud speaker; and the Television picture for the same reason, will not be mixed up with the speech, any more than a violin or a piano, both of which you can readily distinguish with your ear. This is an inadequate comparison, because the separation between the acoustical band or audio frequencies and the radio frequency band is enormously wider than that between any two audible notes of music; and it will therefore be practically impossible for the "sight" waves and sound waves to interfere with each other.

TELEVISION BY RADIO

ENTERS NEW PHASE
Test in Transmitting Sound and Image on One Wavelength Reported a Success.

(From The New York Times, April 20, 1927.)

Transmission of sound and image on a single wavelength, a new chapter in the history of television, was announced yesterday by the Bell Telephone Laboratories through the Associated Press.

In experiments, images were transmitted, simultaneously with speech, from station 3XN, at Whippany, N. J., to New York. The experiment was pronounced a success by Dr. Herbert E. Ives and E. L. Nelson, who directed it.

The first public demonstration of television was made April 7, when speech and images were transmitted from Washington and Whippany to New York. The speech and images from Washington were transmitted by separate wires; those from Whippany by radio on separate wavelengths.

In experiments announced yesterday both speech and image were carried on single wavelengths by radio. It was said that transmission over a single wire also was feasible, in view of the experiment with radio.

Transmission was by a single radio set of a band of frequencies equal to that of several telephone conversations, without distortion or cross-modulation of the various frequencies within the band. A band of 20,000 cycles was used for forming the images and one of 5,000 cycles for speech.

He Bloops to Conquer

By ROBERT FRANCIS SMITH

BACK in the dark ages of radio the delicate art of pounding a little berserk electricity into the atmosphere was indulged in by the hotsy-totsy few, who had time to spare, cash to eliminate, and the inclination to fuss and putter around with eleven miles of number twenty-six copper wire wound on a seven-foot section of vertical pasteboard tubing. Those were the days when a fellow had to write a letter to the nearest "ham" station, fifty miles or so away, and warn the proprietor to keep his single headset on between nine and ten p. m. on Friday, the thirteenth, in order not to miss the dit-dah clicked by the party of the first spark.

Today, radio stations are so crowded that statistics show them to be next to speak-easies in number, and miles ahead of 'em in noise and nerve. And so the old-timers are wont to sit back, give an expert twist to the dial of the new nine-tube mystery, and vent a long sigh for the dead era when the ether was free and you could use a Ford coil or a vacuum cleaner without ruining a bedtime story on some butter-and-egg-man's regenerative hook-up. But all they can do is sigh, and they know it.

The principal excuse for this outburst of senile sentiment is due to The Master—Gerard Lawson, if you believe the census taker. Jerry's an old timer if ever there was one; he began monkeying with that new wireless dingus along back in 1913, and is still at it fourteen years later—and how! It's a Thursday noon in late spring when I drop into his juice joint and discover him in this reminiscent mood.

"H'lo," I says, parking on whatever hap-

pens to be handy. "Why so glum? Income tax or toothache?"

"Oh, hello, Joe!" greets The Master, abstracted: "I feel out of sorts today. Things seem to have gone all wrong."

"Such as?"

"I guess I'm growing absent-minded," confesses Jerry. "I set up a lot of apparatus out in this room before I remembered that I'll have to use that Tesla coil over there."

He points to an immense high-frequency outfit in one corner—quite capable of throwing a thirty-inch spark—and I see the point.

"Why didn't you set it up in the insulated room?" I asks. This latter isn't really insulated; more properly, it's grounded, the room being walled, roofed and floored with sheet steel, creating a fairly static-proof box wherein Jerry sets up stuff he doesn't want to have annoy the outside world.

"I should have," replies The Master. "I just forgot. Now I'll have to do all of that wiring over again, and I had the leads just right. If I use that Tesla coil in here the static it dispenses will ruin any radio reception for miles around. Oh, it's getting worse and worse, every day!"

"What is?"

Jerry flops down into his antediluvian Morris chair. "Radio," he says, briefly. "Even as late as five years ago, one could do almost anything in the line of electrical experimenting without causing the least annoyance. Today, if you start a large motor or an arc, somebody is bound to complain that you're filling their program

with static. And they're right. At present there's no law against my line of work, but I anticipate legislation daily, as these reformers are continually revoking constitutional liberties. Even without a law, they can make it unpleasant for you by social ostracism, particularly in a small town like Brightmere. So far, the folks here have been too kind to remonstrate, but strangers are moving in, since the recent land boom, and frankly, I'm in a quandary."

I nods. "Ain't it the truth?" The town's population has doubled during the last year.

"I saw it coming last summer, when the realtors launched a campaign on the beauties and comforts of our little harbor village. At that time, before I had these new quarters erected, I seriously considered moving out into the desert, or possibly purchasing a remote island in the South Seas, miles from any interference. But one loses so much by not being in immediate contact with the world's developments that I decided to remain here. I have taken all the precautions that I have ever heard of, or can personally conceive, and now I've reached the end of my rope, so to speak."

It's unusual to hear The Master talk so long about himself and his worries. Jerry'll gab for hours about some technical subject, but as to himself he's usually quieter than a radio set with a disconnected battery. I see he's in one of his moods, so I let him ramble.

"Certain experiments requiring unduly excessive input, or which produce interference in too large quantities to be overlooked, I perform on my yacht at sea, as you know." The Master's got a 250-foot sea-going replica of the *Leviathan*, all fitted up like his joint at home. Also, I might add, he's the proprietor of a private railway car, a flock of five-figure automobiles, airplanes of every type, and an income which allows him to devote all of his time to radio and such.

"For a second he stands, sort of paralyzed; then he runs into the laboratory and over to the big Tesla coil and throws in the power."

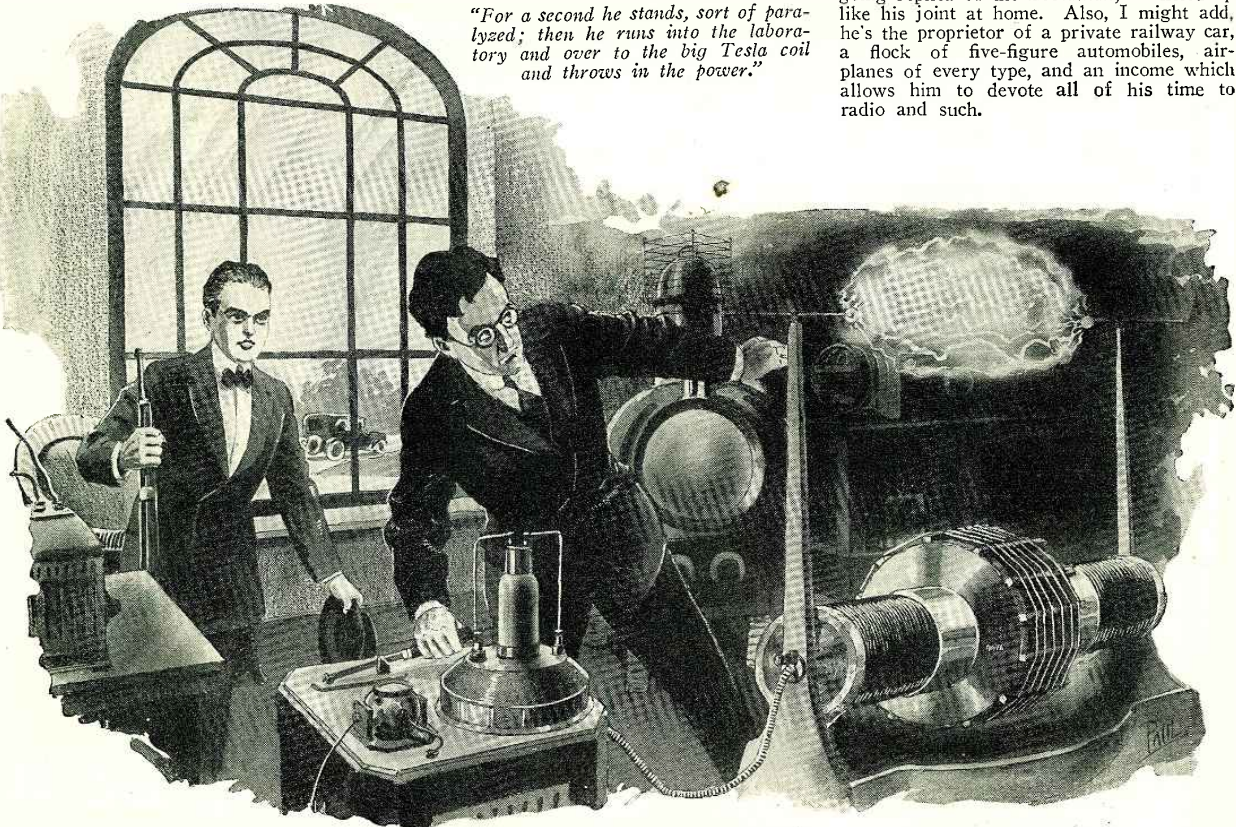

Jerry's in the middle twenties, tall, dark, with less native humor than a fried oyster and better intentions than a drunk on his first wagon. As a scientist he's a marvel, although all of his ideas don't follow the plans with any too meticulous care; still, The Master's a respected figure in the world of science, and has numerous patents and formulas to his credit. Incidentally Jerry is our leading citizen down here in Brightmere-on-the-Deep, Long Island. So far he's single, and has been the season's catch for so long that the local *femmes* have run out of bait. But it doesn't bother him; only once did he fall for a frill. But that faded out when he adjusted his mental dial, so he's normal once more.

"Have you ever tried to eliminate static?" I query, innocently. I ought to have asked the President if he'd ever signed a bill; Jerry eyes me, his jaw almost dropping.

"Have I—Good Lord!"

"I suppose I sounded foolish, but I just wondered—what success have you had?"

The Master gets up from his chair, and paces the floor. "Fully a quarter of the time I have spent on radio has been devoted to the possible subordination of static. I've attempted everything—wave traps, shielding, grounds, and some means I have never made public, with no particular avail.

"The difficulty with static is that it comes from so many divergent sources," continues Jerry, warmed up on his subject. "Static coming from regenerative sets can be eliminated with comparative ease; the manufacture of such sets could, if necessary, be totally forbidden by statute. However, static resulting from motors and arc lamps is quite another matter. Possibly, when small condensers are shunted across motors, even much of this type of interference can be done away with. But the greatest source of static—nature—will always be with us. To remove natural interference one would of necessity have to remove also the radio waves themselves, both being identical in principle. Static is the nemesis of radio, has been, and I am afraid always will be. I cannot say one solitary good thing for static. It is a noxious parasite, nothing more nor less."

I agreed: "You said it—still, what poetic goof was it that yelped about there being some good in everything, if we only looked hard enough?"

The Master grunts. "Poets are never practical," he states. "There is no possible, legitimate use for static, in any form. And I believe I have had sufficient experience in such matters to constitute myself an authority on the subject."

By which he inferred he don't mean maybe, so I let it lay.

About two o'clock the third assistant flunky to the guy that opens Jerry's front door on the afternoon shift comes up the steps with the mail and papers. As usual, The Master's daily ton of begging letters have been opened and dispensed with by his secretary in the house; the *bona fide* mail Jerry gets direct to the laboratory, including magazines and similar stuff. I pick up the first evening edition of Jerry's pet paper, and heave a gasp at the headlines.

"Boy!" I exclaim. "There's been a big bank robbery up the island at Willomere—\$50,000 cash!"

The Master takes the sheet from my hand. "Let me see," he says, reading. "At eleven-thirty this morning—four men, with black beards, in an expensive imported car—no trace of them—hm?"

"No clues at all," I says. "Odd, ain't it?"

Jerry continues to read. "The car was traced up to the crossroads a mile east of Harkey; between that point and Harkey, the automobile completely vanished."

I grin: "Can't these hick dicks even find



What we see is four black-bearded men . . . jump into an auto and tear out towards New York.

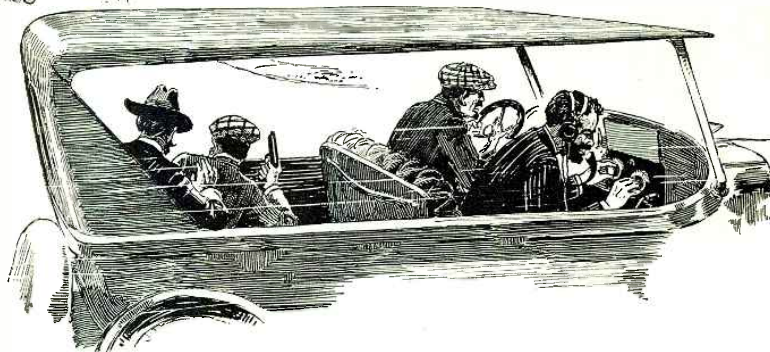

a loose car?" I asks, sarcastic. "Seems like the thing's too good to be true."

"Just too good to make it enticing for us," states Jerry. "Suppose we find the car?"

"We?" I repeats. "Are you kidding?"

"Indeed not. Since this seems to be an off day for me, why shouldn't we amuse ourselves by tracking down these criminals?"

"Cute," I grins. "I'm with you. Have we got time to run up to Willomere before I hit the asphalt for the bright lights?" Pardon my oversight; I'm Joe Hammerstein, dancer, at present with the long-run *Inanities* on Broadway, the confidence man's paradise. Also, the wife is a toe-stubber, being little Joe's partner on and off the rostrum.

Jerry glances at the chronometer on the bench. "It's not two-thirty yet," he says. "Surely we've time to run up twenty miles and look the situation over while it's warm. I'm interested in seeing where and why an automobile could vanish so successfully."

So we jump into The Master's Wop roadster and breeze up the isle at about forty-five—the cops are respectful when Jerry's at the helm—and soon we hit the corner grocery masquerading as the town of Harky. Jerry gets out and asks a few questions, but it takes time, so we've only long enough to drive up and back the given mile.

The section in question winds through what pass for hills, along the center ridge of the island. It's wooded, sort of Sleepy-Hollowish, with the road winding about through small gullies and over rustic bridges. The highway today is crowded with villagers out car-hunting, so we don't delay long, beyond failing to see any feasible hiding place for an automobile; nor is there any place where a car could be turned from the road and be run through the woods. Everything is being inspected by everybody, it seems, so we rush back home so's I can drive the frau into town in time to do the Black Bottom for the visiting firemen.

All the way home Jerry's silent, and I know the signs by this time. The Master is involved in deep thought. I don't press inquiries, but I get sorta' curious. When we arrive at Brightmere I finally breaks the ice and ask what's what.

"I suppose it's all none of our business," muses Jerry, "but nevertheless I'm wondering how that car was spirited away. Shall we go back tomorrow?"

That day being a Friday, with no other calls on my time, I agree. When I gets back to the love nest Doris, the sardine specialist, slips me the first torture on the regular evening inquisition.

"Whereya been?" she snaps.

"Out joy-riding with The Master," I replies, cheerful. "Why? Need help to open a can of beans?"

"Don't get tepid," advises the house committee. "Hurry up and eat dinner—if there's another traffic jam like the one last night we'll be late for the show."

There ain't, which is pure good luck, and thus deprives Doris of what looked like material for a week's bawling-outs. So she's peevisht and sullen, and won't speak to me, except on the stage, where she smiles radiantly and feeds me my lines. At home she hangs me with them.

Early next morning—no kidding—I'm over to Jerry's, and we take the trip again, this time going carefully over the ground. About half the population's already done the same, and the car ain't been found.

First The Master goes to the crossroads at the astern end of the mile stretch; said crossroads consisting of a filling station and hot-dog stand. The proprietor vividly remembers four strangers, bearded, stopping at his place for gas.

"They crabbed something fierce about the price," he says. "It's no higher here than any place else, either. Sounded fishy to me."

Back we go to Harkey, and interview most of the sitting populace, including the constable, whom we'd missed seeing on our first trip. The Master is a consulting engineer, or scientific expert, for a large well-known international detective agency; his badge opens the law's lips *pronto*.

Willomere lies fifteen miles east of Harkey, on a gravelled road. Jerry and I listen to the constable's story, and then The Master asks a few questions.

"Much travel on this road?"

"Some," drawls the cop. "Not heavy though, this early in the year. We get a big week-end draw, but other times there ain't more'n fifteen or twenty cars an hour."

"By any chance, do you recall any unusual traffic on the day in question, bound either way?"

The law scratches his head. "Some of the boys seen the black car go through towards Willomere, and told me about it," he says, slow. "Even that wasn't what you'd call out of the way—there's a lot of foreign cars on the island—and I wouldn't of thought much of it, if the robbery hadn't occurred."

Jerry pauses, meditating. "Were the men bearded?"

"No," says the officer. "We'd have noticed that immediately."

(Continued on page 77)

The Time Chime At WRNY

Automatic Time Signal Every Hour on the Hour

By HUGO GERNSBACH

RECENTLY there has been installed at Station WRNY, New York, a new time instrument which now broadcasts the exact Western Union time in a fashion wholly automatic. The advent of the device was announced in the press during February this year; but, because of the labor involved, as well as the testing and perfecting of the automatic feature, the Time Chime was not actually put into commission until the first part of May.

In designing the Time Chime, I had in mind an automatic clock which would give the public the exact time every hour on the hour, or as near this as is feasible. At the present time, time signals are sent out from Arlington, Virginia, by Station NAA, giving Naval Observatory time. Here every tick of the clock is broadcast, starting a little before noon and a little before 10 P. M., E. S. T. The exact hour is usually designated by a long dash. A number of broadcast stations are retransmitting these time signals. While this is an excellent service, I always have felt that a more complete service is needed; that is, if possible, we should transmit exact time signals each and every hour.

The Time Chime is the result of this thought. Many technical difficulties had to be overcome in the design of the Time Chime; but, after it has been installed and operated for some weeks, it can now be said that the results are quite successful.

Just at the stroke of the hour, the apparatus automatically sounds a melodious Westminster Chime note; so exact is the time that it does not vary more than one-fourth second at any time. Radio listeners may therefore set their watches more exactly than has been possible heretofore. The only time signals of equal accuracy are those transmitted from Arlington, Virginia, through NAA, by the Government station at that point.

IN THE STUDIO

Several innovations have been made, among them the following: 12 seconds before the Time Chime goes on the air, a red warning light flashes in the studio of WRNY. If no program is on the air at the time, the announcer pushes a switch and says:

"The Electric Time Chime will now give you the exact Naval Observatory Time by Western Union. It is now —, Eastern Daylight Saving Time," then, immediately afterwards, the Time Chime sounds. If, as happens at times, there is a program going on which runs over the hour, the Time Chime is allowed to sound without the preliminary announcement, as its single clear note does not interfere with the program. This accurate signal may therefore be expected by the listener at the beginning of every hour while WRNY is transmitting.

All of the contact arrangements, such as the flashing of the warning light twelve seconds before the Time Chime is sounded, and the actual sounding of the Chime, are made

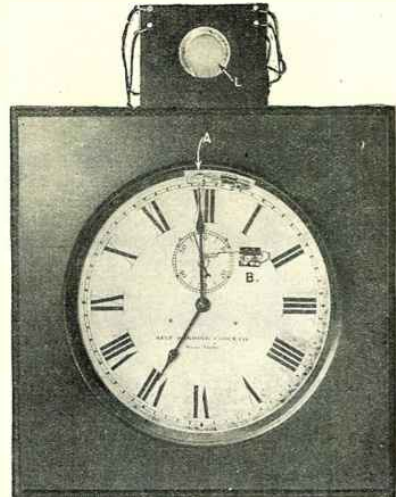

Above, the face of the Time Chime just before the signal; the minute hand has closed a switch, A, as shown in the diagram below. Twelve seconds before the signal, the second hand closes another and the pilot lamp, L, lights. The announcement is then made to the radio audience, and the Western Union signal strikes the chime, which goes out through WRNY's transmitter.

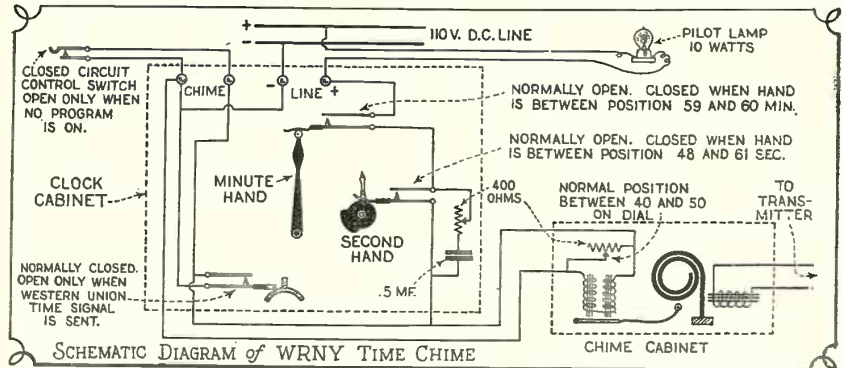

Below is the interior of the Time Chime mechanism, removed from the cabinet. At the back of the panel, on which is mounted the rheostat H to vary the intensity of the sound. C is the Westminster Chime gong, energized by the rubber-tipped clapper H mounted on the armature of the electric sounder M. When the clock establishes the contact, the armature M is drawn sharply inwards, thus making H strike the gong C. The sound of the chime is broadcast, not by microphone, but by an electro-magnetic pick-up, which is nothing but a special telephone receiver, shown at T. The screw R serves to regulate the distance of the armature, attached to the gong, in relation to the receiver T, in such a way that it insures the best transmission of the sounds possible.

by the clock itself. No human hands interfere or adjust anything.

One of the most intricate problems which had to be solved was caused by the correcting signal sent out by the Western Union Telegraph Company every hour. The clock used is governed by a pendulum, and might lose or gain a half a second during the hour. The Western Union Telegraph Company sends out a signal, which corrects the clock at the end of each hour. So the electrical contact arrangement of the Time Chime had to be arranged in such a manner that, when the correcting signal comes, it is a part of the normal operation of the Time Chime.

CIRCUIT USED

This problem was finally solved in an interesting manner. The accompanying sketch gives the schematic diagram of the Time Chime, from which all the technical details can be readily seen. The Time Chime uses no batteries at all, it being my idea to have an electromagnetic pick-up located about an eighth of an inch away from the "gong" chime. The latter is a square piece of steel wire carefully tuned and mounted on a heavy piece of brass. Such a chime can be bought from large clock makers; it is the identical "gong" used in some of the better "grandfather" clocks.

The telephone receiver, T, in the illustration, is placed in such a way that it comes quite close to the "gong" chime; and the vibrations set up when the clapper strikes the wire are picked up by the telephone receiver. This eliminates batteries and microphones,

(Continued on page 80)

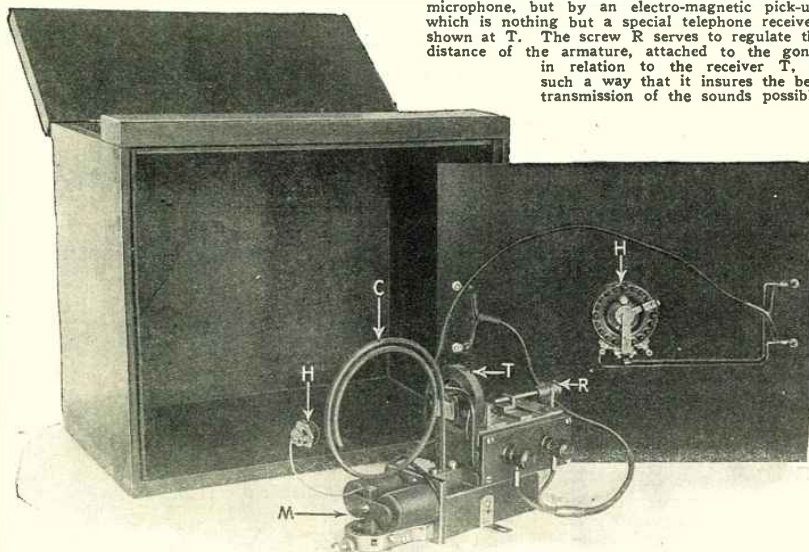

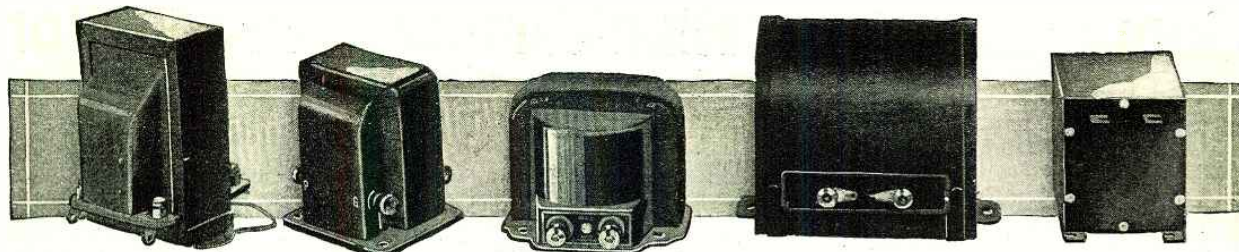

Above are shown typical loud-speaker coupling devices. The first two, at the left, are output transformers; the next two are straight choke coils, which must be used with a large fixed condenser like that at the extreme right.
Illustrations courtesy the Pacent Electric Co., the All-American Radio Corp., Acme Apparatus Co., and Tobo-Deuschmann Co.

Why Loud-Speaker Coupling Devices are Necessary

An Explanation of How These Important Instruments Improve Reproduction

By I. F. JACKOWSKI

SINCE the initial entrance of power amplifying tubes into radio reception, loud-speaker coupling devices and output transformers have found wide employment. When power tubes are used, heavy currents are amplified. These range from 5 to 25 milliamperes, depending on the type of power tube in use. Loud-speaker coils are not designed to carry heavy currents, so some form of protection must be provided to protect the loud speaker from burning out.

A loud speaker is made on the order of a pair of headphones. It consists of one or more coils wound on a permanent magnet, or else located directly in the field of said magnet. Upon the application of a current to the coils, the loud-speaker diaphragm will move once, causing a click to be emitted from the speaker. This effect can be observed by connecting the terminals of a loud speaker across a source of voltage (a dry cell or storage battery). You will find that, upon making a circuit, a click is heard in the loud speaker. However, no other action will take place, because the current flowing in the coils is a direct current, and this smooth current has not the power to actuate the diaphragm steadily.

INTERMITTENT ACTION

Only by the making and breaking of the circuit will the diaphragm be actuated. If you disconnect the speaker terminals from the battery, you will find that the loud speaker produces a click. Sound is caused also by a modulation of the flow of current, or a sudden variation of voltage. To verify this effect of modulation, put the speaker directly across a source of alternating current (a 110-volt, 60-cycle house line is suitable) for a few seconds. You will hear a clear alternating-current hum as a result of the reciprocating movement of the diaphragm. The steady actuation of the diaphragm is caused by the continual reversals of the alternating current. During the reception of broadcast signals, the diaphragm of the loud speaker is actuated by the reciprocating action (modulation) of the transmitted voice or music.

DOUBLE NATURE OF CURRENT

In the actual reception of programs, a current consisting of two different components flows through the loud-speaker coils. The first of these components performs no desirable function, so far as the loud speaker itself is concerned. The second is the beneficial one, and responsible for the reproduction of the transmitted voice and music. The undesirable component is the direct current furnished by the "B" batteries or socket-power unit, whichever the supply source may

be. This direct current starts flowing through the speaker windings as soon as the filament-plate circuit is closed (i. e., when the filament switch is pulled out and the rheostats turned on) and flows as long as the filament switch remains closed. The opening of the latter stops the flow of all current through the speaker windings.

If the speaker is improperly connected this direct current will have a tendency to demagnetize the loud-speaker magnets, thereby weakening the instrument. If the direction of the D.C. is such as to aid the magnetic effect, a heavy current from a power tube may cause the magnets to hold the diaphragm down and make it "chatter" when music is received.

The second component is the alternating-current wave which represents the transmit-

only the alternating-current component, which represents the actual transmitted voice and music. This may easily be accomplished by employing one of the three methods here described. The diagrams of connections are given in Figs. 1, 2 and 3.

EXPLANATION OF COUPLING CIRCUITS

Fig. 1 shows a choke coil of about 100 henries value connected between the positive terminal of the "B" battery and the plate of the last audio tube. A fixed condenser of from 2- to 20-mf. capacity is placed between the plate lead and one loud-speaker terminal, the other terminal going to the bottom end of the choke coil.

Fig. 2 is practically the same as Fig. 3, both giving equally good results. The fixed condenser shown across the loud-speaker terminals is not required unless the tone quality is harsh. The condenser, if used, can be from .01- to .1-mf. capacity. Condensers of between .001- and .01-mf. capacity connected across the primaries of the audio transformers will serve the same purpose. In these arrangements, the direct-current component of the entire plate current circulates through the choke coil rather than through the loud speaker, because it cannot get through the large fixed condenser. However, the alternating-current component, which represents the transmitted voice and music, can readily pass through the large fixed condenser and into the loud speaker, where it is reproduced as actual sound.

The method shown in Fig. 3 is also very effective. It makes use of a transformer which is designed especially for this purpose. Here the primary of the coupling transformer, in which the direct-current component is circulating, takes the place of the loud-speaker coils. Since the transformers operate only on alternating current, the A.C. component which represents the modulating voice and music only is induced into the secondary of the coupling transformer, and the loud speaker responds audibly.

ACTION OF THE SPEAKER

The loud speaker is connected to the secondary of the transformer as shown in Fig. 3. It emits no sound unless the receiving set is tuned to some transmitting station.

The alternating current in the secondary circuit of the transformer actuates the diaphragm of the loud speaker to correspond to the variations of the transmitted voice or music.

To make this action more clear to the layman, further explanation is in order regarding the induction of current into the secondary of a coupling transformer.

(Continued on page 68)

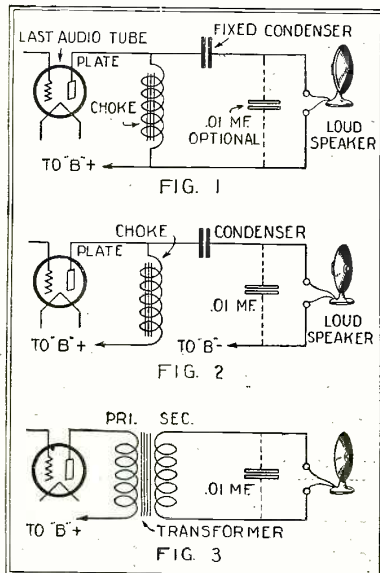

Three methods of coupling the loud speaker to the last amplifier tube are shown above. Figs. 1 and 2 are very much alike; in Fig. 3 an output transformer is indicated, instead of the choke and condenser.

ted voice or music. It is this component which performs the desirable function of diaphragm actuation. As the direct current performs no desirable function in the loud speaker as far as reproduction of music is concerned, it is desirable to eliminate this entirely and to feed the loud speaker with

Some Aspects of High-Quality Reproduction

How It Is Furthered in Radio Receiver Design by Suitable Circuit Values

By PAUL TRAUGOTT

THIS article is in two parts, the first dealing with the R.F. and detector, and (in superheterodynes) the intermediate-frequency and second detector stages. The second part, appearing next month in RADIO NEWS, will be devoted to the A.F. amplifier and loud speaker. It will well repay reading by the constructor who is interested (and who is not?) in obtaining a better quality of output, here defined as fidelity to the original program in both low and high tones, as well as the intermediate. —EDITOR.

IN recent months various products of the art of electrical sound-transmission have been brought to the attention of the general public. The Vitaphone, the new phonographs, public-address systems, good broadcast stations and good broadcast receivers, all make use of what are known as "high-quality" reproducing or transmission systems.

The term "high-quality" is in itself somewhat arbitrary; for the best of high-quality amplifying systems may not always transmit and reproduce a quality of music or speech that is in itself very high. In any event, the estimation of the quality of what emerges from such a system is dependent to a large degree upon individual taste. Properly speaking, the above designation refers to the equipment in the system rather than to what it is required to transmit and reproduce; "high-fidelity" amplifier might be a more definite nomenclature. Nevertheless, in this discussion the more popular term will be used.

A high-quality reproducing system may be defined as one that transmits and reproduces, with the highest degree of perfection and fidelity, sounds or groups of sounds, originating at some point outside of the system itself. The system so arranged is electro-mechanical, electro-physical, or electro-acoustic; either of these terms describes it fairly well. The electrical part, of course, usually comprises the associated vacuum-tube amplifiers and the loud-speaker drive mechanism; the mechanical, physical, or acoustical part being in the final vibrating member of the loud speaker or reproducer. Though much in the way of instruction and advice has recently been written on the subject, it is not quite true

that true high-quality reproduction is always favorably received by listeners to radio broadcast entertainment.

SOLVING THE PROBLEMS

High-quality transmission and reproduction probably began, in this country at least, in the laboratories of the telephone engineers. The art was given its first great impetus when two telephone engineers developed the condenser microphone, or condenser pick-up. Since the pick-up is the first step in any electrical sound-transmission system, the advent of this device inaugurated a new era in practical high-quality apparatus. There had been so-called public-address systems prior to the invention of the condenser transmitter; but they were pretty sad affairs, producing great quantities of noise, with almost zero intelligibility in speech and terrible distortion in music. Other perfections rapidly followed the new microphone, for the great majority of which credit is also due to telephone engineers.

It is now common knowledge that electrical sound-transmission and reproduction resolves itself into the problems of producing and amplifying a group of electrical impulses having frequencies related to the sounds which originally produced them, and then of re-converting these electrical currents into sound waves. For the most perfect reproduction, the band of frequencies which must be provided is very wide. In the ideal case it is necessary to transmit equally through the system all frequencies from 16 cycles per second to at least 10,000 cycles per second.

A PRACTICAL PROBLEM

At present, without the complications introduced by radio transmission, it is probably possible to accomplish this ideal in a well-equipped laboratory. But such perfection, though scientifically and aesthetically desirable, is not entirely necessary. For practical purposes, a system that transmits equally from 30 to 7,000 cycles, and delivers these frequencies with wave-forms unchanged, and at the proper intensity level, as sound waves from the loud speaker, is a very high-quality system. The transmission of a band from 50 to 5,000 cycles provides excellent quality and a high degree of naturalness in the sound output. Even if all the frequencies between 100 and 4,000 are passed equally the quality is still very good.

Variations of as much as ten per cent in the equal amplification of these frequencies

are probably allowable. The wave-forms of the currents must remain substantially unchanged. The most elementary reasons why the original wave-forms must not be disturbed are: first, the absolute quality of a sound is determined largely by the form of the wave it produces, or which produces it; second, distortion of wave forms causes the production of harmonic currents, which are reproduced finally as tones that were not present in the original music, speech, or whatever it was. In music, the interaction of such locally-generated harmonic currents with the normal currents results in dissonance.

Though at the present the most prevalent use of amplifying and reproducing appara-

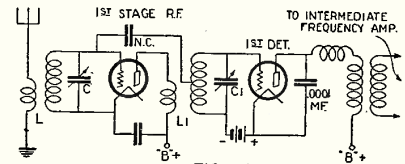

FIG. 1-A

Showing how a tuned R.F. stage is placed before the first detector in a superheterodyne.

tus is, of course, in radio broadcast reception, nevertheless, the later day phonographs are interesting examples of sound-transmission engineering. Mr. Edison recently expressed the opinion that phonographs gave better reproduction than radio sets. He received, for his temerity, vituperation from whole assemblies of radio experts. Yet Mr. Edison's remarks were not altogether unsound (though it may be *lese majeste* for a radio man to admit so much). But the fact is that the new phonographs, panatropes, orthophones, and so on transmit well all frequencies from about 100 cycles up to and above 4,500. Even greater ranges are claimed, and probably justly, for some of the machines. Also, the new records are cut with frequencies covering a still wider band of tones, though with probable slight deficiencies at the very high and very low extremities of the scale. As before indicated, such transmission systems give very high quality. Now the majority of present-day radio receiving sets (Mr. Edison probably referred to the generality of radio sets) do not, as a matter of sober physical fact, do so well. And, though it is possible to design a radio receiver to do as well and even considerably better, there are special complications which militate against this and, in the case of long-distance reception probably make it impossible. One factor alone—and one which is entirely beyond the control of both the transmitting and receiving engineer—that is sufficient, with the present-day type of radio transmission, to render reliable high-quality reception of distant stations difficult, is the fading of the sidebands in the radiated wave; this causes distortion of quality sometimes to a considerable degree. Static and other extraneous noises are always to be reckoned with. The range over which high-quality radio reception is at all times possible is rather limited; it has been put, by one authority recently, at about thirty miles for a five-kilowatt broadcast transmitter.

The difficulties attendant upon high-quality broadcast transmission have, at the

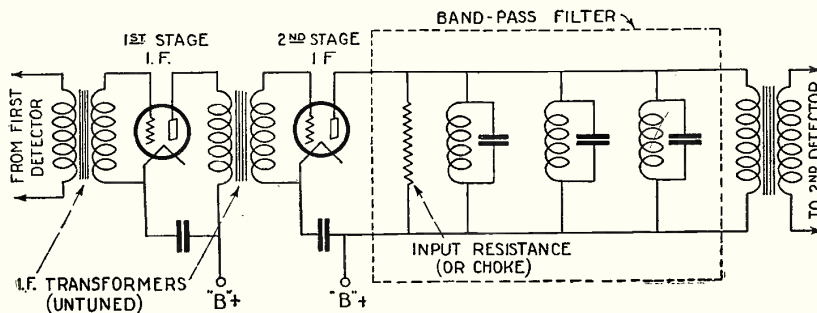

FIG. 2

Here is shown a band-pass filter, located in the output of the I.F. amplifier of a superheterodyne, for the elimination of distortion.

broadcast-station end, been pretty well overcome; the transmission from a first-rate broadcast station is of very high-quality. But at the receiving end new troubles begin. The nature of some of these will be considered.

HIGHER TONES REDUCED

It is probable that the outputs of most existing radio sets, with their associated loud speakers, are quite deficient in the higher frequencies—from 3,000 cycles up. In addition, many of them discriminate strongly against the very low frequencies. In recent receiver design, stress has been placed on low-note reproduction, for the presence of low tones in the output results in a much more pleasant musical effect. Great improvements have thus been made in low-note transmission. But the difficulties especially attendant upon radio reception and reproduction are mostly of such a nature that the high frequencies are reduced. And, to get real high-quality reproduction, this must be corrected.

A radio set of necessity usually has some kind of radio-frequency amplifying system.

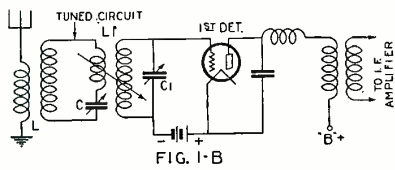

FIG. 1-B

This diagram illustrates how the circuits may be arranged without the addition of an R.F. tube.

Consider first the superheterodyne. This arrangement can be engineered into one of the best of radio receivers; it has at least one special advantage which makes its development worthwhile. A superheterodyne, in order to perform well in crowded radio districts, must have its input circuit made fairly selective. For if more than one radio frequency from outside gets into the first detector, double beats and resultant heterodyne whistles will usually result. Especially is this likely to occur if a desirable intermediate frequency is chosen for further amplification.

REARRANGING THE SUPERHET

The simplest way to eliminate this difficulty is to put a stage of signal-frequency amplification before the first detector; this provides two tuned circuits instead of one and, if properly built, will ordinarily give the requisite input selectivity.

Fig. 1A shows the conventional arrangement. Fig. 1B shows how two tuning circuits may be arranged without the requirement of an additional tube. This latter arrangement is simple and cheap; but of course the first method gives an additional stage of amplification and so greater sensitiveness. (It is not always desirable, however, to have amplification at this point; it is better utilized in the I.F. system).

In this superheterodyne circuit, considered up to the output of the second detector (the audio system will be considered in the second article), frequency distortion, in the form of discrimination against the higher frequencies, occurs as follows: first, in the two tuned circuits forming the input of the detector, it is not likely to be serious if excessive regeneration does not occur, but it is usually not entirely negligible; secondly, in the intermediate-frequency amplifier, with the usual circuit arrangements frequency distortion at this point is likely to be serious. In the efforts to gain selectivity the tuning of the output or filter transformer is usually made quite sharp, and at the frequency or wavelength therein being amplified, the upper com-

ponents of the audio sidebands are considerably reduced.

The third serious decrease in the upper audio frequencies occurs in the second detector circuits; in this place it is due to the combination of the grid condenser and high-resistance leak. Under certain incorrect conditions of by-passing, further depression of the high frequencies may occur in the output of the second detector. It has been assumed that the first detector is arranged for straight rectification, which method is in general most satisfactory. But this connection increases the output impedance of the first detector, which often results in instability of the I.F. amplifier; for which reason a grid-leak-condenser arrangement might be preferred for the first detector.

CORRECTION OF DISTORTION

By proper design, much of the frequency distortion as noted in the foregoing can be obviated. The not very serious effect of the first two tuned circuits can, if the very highest degree of precision be desired, be corrected by merely increasing the damping of the tuning circuits; high-resistance coils, shunt resistors, etc., will do this easily.

Correction for frequency distortion in the I.F. amplifier is not so readily accomplished. If the tuned filter stage or stages are highly damped, the selectivity of the receiver as a whole will largely vanish. A rather high intermediate frequency may be of some advantage. But the only first-rate method is to include somewhere in the I.F. amplifying system a band-pass filter, to pass equally a band of frequencies at least ten thousand cycles wide or, with certain other methods of operation, at least five thousand cycles wide. With the use of this device the highest selectivity commensurate with high-quality reproduction is obtained.

Band-pass filters are not easy to build, and patents probably preclude the more extensive commercial distribution of them. Hence the usual superheterodyne intermediate frequency amplifier is built for high selectivity and whatever quality can get through it in spite of the selectivity. Fig. 2 shows the band-pass filter in the output of the I.F. amplifier.

IN THE SECOND DETECTOR

The frequency distortion due to the second detector can be avoided by one of two simple expedients; both of which, however, reduce the sensitiveness of the receiver. The first method uses the plain-

rectifier principle in the second detector; this scheme is variously known as plate-rectification detection and grid-bias detection. The detector-tube grid is merely biased negatively to such an extent that it functions as a simple rectifier. The audio frequencies get through equally or are produced equally, and the frequency distortion is therefore absent. Unfortunately, with this arrangement, the output impedance of the detector tube is higher than is desirable, a disadvantage that will be mentioned later.

The second arrangement provides merely for the use of a rather low grid-condenser capacity instead of the usual .00025-mf. About .0001-mf. gives some improvement. But the lower value of this capacity also reduces the radio-frequency voltage reaching the detector grid, and so the signal strength falls. Such small grid-condenser capacity also keeps the detector grid pretty well at free potential for all audio frequencies; which, unless the grid leak be lowered in value, is not always desirable. In this second method the output impedance of the tube is very much lower than in the case of the grid-bias detector.

Before leaving the subject of superheterodynes it might be stated that the double-detection circuit has, for distant reception, the marked advantage that its first detector output varies linearly with input voltage. Thus it performs well on weak signals. The ordinary non-regenerative or non-heterodyned detector works on the input-squared law, and so gives relatively higher outputs from moderate and strong signals than from weak ones.

TUNED-RADIO-FREQUENCY SETS

Another popular form of R.F. amplifying system is that known as tuned-radio frequency, or T.R.F. The usual form of this consists of two, three, or four stages of R.F. amplification, followed by some form of detector and audio-amplifying system. By properly balancing and stabilizing the system and providing a sufficient number of stages of amplification, the over-all voltage amplification available in such an arrangement can be made to equal, or even to exceed, that of the ordinary superheterodyne; though it has not the advantage of the linear first detector.

In the T.R.F. circuit, frequency distortion is primarily a function of the damping of the individual tuned stages; the lower the damping, the greater the depreciation of the highly modulated frequencies before

(Continued on page 68)

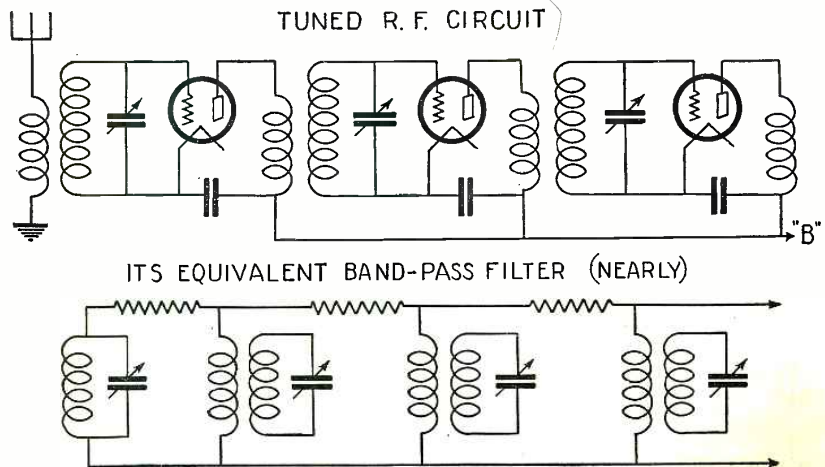
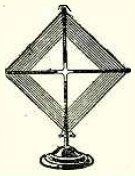

FIG. 3

The lower circuit is approximately the equivalent of the upper one, which means that there is in it practically negligible distortion.



The Strobodyne Circuit

A New Frequency Changer
By LUCIEN CHRÉTIEN (Paris, France)
Part I

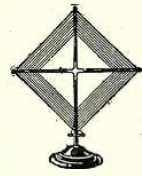

HERE is another circuit with a "dyne" ending! True, there are many "dynes" already, but the only way to distinguish something new from something already existing is to christen it. The name "Strobodyne" was coined because the system employed is somewhat similar in operation to the Stroboscopic phenomenon, which is explained in this article, and to distinguish it from other circuits derived from the superheterodyne.

The main characteristic of the superheterodyne, tropadyne, second-harmonic "super" and the like is the interference of the incoming signal with local oscillations, the intermediate frequency being produced after the resulting beat note is detected. The detection may be obtained by any standard method, such as grid condenser and leak, operation on the bend in the tube's grid voltage-plate current characteristic, crystal, etc. In the ultradyne there is no detection as generally understood; there is modulation. Modulation is accomplished also with the double-grid tube, but the actual functioning is different.

1A), when the motor turns at a speed of say 1,500 revolutions per minute, the line becomes invisible. Now suppose that the electric light in the room is turned on and off 1,499 times a minute. You will then see the black line turn slowly around the disc at the speed of one turn a minute, like the second hand on a clock (Fig. 1B). This effect may be accomplished either by using as the source of light, a neon tube supplied with alternating current of the proper frequency, or by placing between the observer and the disc a rotary shutter revolving at the proper speed.

The "frequency" of rotation of the disc in this case is 1,500 r.p.m., that of the light 1,499, and the resulting frequency 1,500 minus 1,499, or 1. This explanation should make the stroboscopic (from the Greek "twisting of vision") phenomenon clear.

If the black line on the disc is as shown at A (Fig. 1), when the motor starts one may see it. The light goes out during 1/1499 of a minute, then goes on again; during this time the disc will have revolved one turn plus 1/1500 of a turn. When the

will greatly help the reader to understand the operation of the Strobodyne, so we shall review it here briefly.

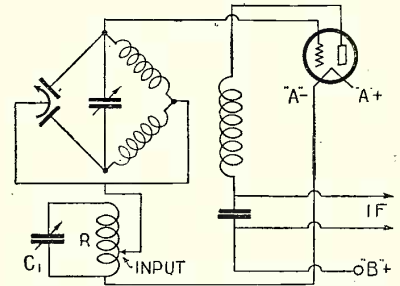

FIG. 5

This circuit tunes sharper, with louder signals, than the one in Fig. 4.

For instance, to determine if a 50-cycle A.C. generator produces harmonics, the Ondograph is connected to it. It is com-

THE YEAR'S GREATEST RADIO CIRCUIT

THE study of a well-known optical principle has led to the device by M. Chrétien of an entirely new circuit in which is utilized an analogous electrical principle. The Strobodyne operates, not by causing two frequencies to beat; but by providing a conductive path for the signal only during the phases of suitable polarity in the oscillating circuit which operates in the fre-

quency changer. It results in the production of a receiver of rare sensitivity.

In this article the inventor explains his system in simple fashion; in the next of the series, to appear in August RADIO NEWS, constructional details will be given for the building of an eight-tube Strobodyne with American apparatus; and, in the third and last article, in

our September issue, practical advice on the operation of the Strobodyne.

The appearance of the Strobodyne, in our opinion, marks a new epoch in superheterodyne construction; and we are confident that constructors will find this exceedingly sensitive and powerful receiver a very interesting and satisfactory one.—EDITOR.

THE STROBOSCOPIC PHENOMENON

If a black line is painted on a white disc mounted on the shaft of a motor (Fig.

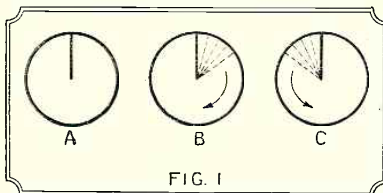

FIG. 1

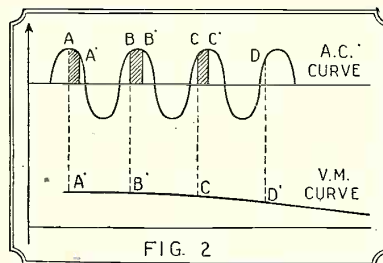

FIG. 2

Fig. 1 illustrates the apparent slow rotation of the line, known as the stroboscopic phenomenon. Fig. 2 shows the electrical variations as measured by the ondograph.

light goes on again the observer will see the line a little further towards the right (supposing that the motor turns in clockwise direction). As this action takes place rapidly, it seems that the black line is moving around the white disc like the hand of a clock. If the light were turned on and off 1,500 times a minute, the black line would appear to be motionless (as in Fig. 1A) although the disc would actually be revolving at 1,500 r.p.m. If the light is turned on and off at a slightly greater speed, the black line will appear to turn backward (Fig. 1C).

This same effect is obtained in numerous cases wherever there is a periodic motion. For instance, one may observe the action of an automobile engine running at 3,000 r.p.m. by means of a light turned on and off 2,999 times a minute. The engine would appear to turn at 1 r.p.m. and the action of the pistons, valves, etc., could be observed as if seen in a slow-motion picture.

AN ELECTRICAL ANALOGY

The Strobodyne circuit, which is now presented here for the first time, is based upon the same principle, except that electric actions take place instead of optical ones. A similar system is used in the "Ondograph," a French instrument designed to register the waveform of alternating power currents. The explanation of its operation

posed of a small synchronous motor (whose speed is regulated by the frequency of the current) operating a commutator through a train of gears designed to rotate it 49 times while the motor revolves 50 times. This commutator connects in the circuit a condenser, the voltage across which is measured by a registering voltmeter. The operation may be better understood by referring to Fig. 2. If the commutator closes the circuit at the point A on the A.C. curve, the condenser becomes charged and discharges through the voltmeter, which indicates the voltage A' (V.M. curve). During the next cycle the commutator again closes the circuit, but 1/50 of a turn later, on account of its rotating more slowly than the motor. At B the condenser is charged again, and the voltmeter registers as shown at B', indicating a slightly lower voltage. Since the voltmeter is highly damped and does not fluctuate between successive readings it indicates the various values of voltage every 1/49 of a second; and one may see the variations of a 50-cycle alternating current registered at the speed of 1 cycle a second. This apparatus, in other words, is a true frequency changer.

THE STROBODYNE PRINCIPLE

Now suppose that, instead of low-frequency alternating current, radio frequencies are used. We replace the condenser-voltmeter system by a circuit

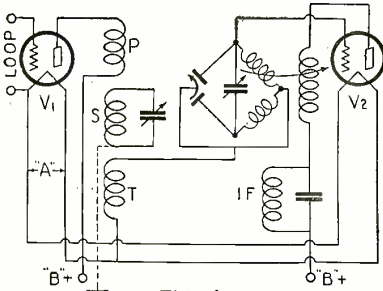

FIG. 6

A further improvement on the circuit shown in Fig. 5, having the R.F. transformer in three sections.

containing inductance and capacity, forming an oscillating circuit, and if it is tuned to the intermediate frequency a current will flow through it every time a beat note is produced. At any given instant the oscillations through the circuit will have an amplitude which is in direct ratio to that of the applied ones. This means that if the applied oscillations are modulated, the intermediate frequency will also be modulated. When there is resonance between the oscillating circuit and the successive impulses passing through the commutator, each impulse is applied in phase with those already flowing through the circuit. This is the principle used in the Strobodyne. The only thing to find is the commutator to operate at radio frequencies. In the Ondograph, alternating currents of 50 cycles or so are used, but now high-frequency currents of the order of 1,000,000 cycles and more are to be handled.

One may readily understand that it would be impossible to build a mechanical commutator to operate at these frequencies. However, thanks to modern physicists, the smallest known particles of matter, electrons, are now domesticated and the vacuum tube supplies the commutator which we shall use.

THE TUBE COMMUTATOR

When a vacuum tube oscillates at a wavelength of 300 meters, corresponding to 1,000,000 cycles per second, the grid becomes alternately negative and positive 1,000,000 times a second. When it goes positive a current flows through the grid-filament circuit and the grid-filament space-resistance decreases. It decreases so much, in fact, that as far as radio frequencies are concerned, a circuit connected to the grid is practically short-circuited. On the contrary, when the grid goes negative, the grid-filament resistance becomes practically infinite. It can therefore be seen that a circuit connected between the grid and filament may be considered as being short-circuited 1,000,000 times a second. This action provides the automatic commutation required.

THE STROBODYNE CIRCUIT

Using the foregoing explanations, we may now show in detail the functioning of the Strobodyne. See Fig. 3. R is the tuning circuit through which the received oscillations, the frequency of which is to be lowered, are applied to the tube. This circuit is coupled either inductively (or capacitively as shown by the dotted lines) to the circuit, IF, tuned to the intermediate frequency. G is a circuit tuned to the frequency of the local oscillation to be generated by means of the feed-back coil, P. This simple diagram will allow us to show, among other things, that there is in this case neither modulation nor detection.

One of the main advantages of the system is that the tube is used not only as an oscillator-controlling bulb, but also as an amplifier. This is probably why, for a

given number of tubes, the Strobodyne is generally more sensitive than other "supers."

The diagram shown in Fig. 3 is practicable, but its operation is not quite as explained in the description of the Ondograph (Fig. 2). In the case of the latter, the commutator acts during a very short time, this being even reduced in the diagram to mere points (A, B, C, D, etc.). But it is easy to show that the same phenomenon occurs if the time of operation is longer, so long as it does not extend over exactly a full cycle or one of its harmonics.

If one assembled the circuit shown in Fig. 3, several difficulties would appear at once. The oscillations through circuit G would stop for some settings of the tuning condenser, C1, because the local oscillations would be close in frequency to the received ones. It is, therefore, necessary to use some form of circuit in which the tuning of one circuit does not affect the other; in other words a system similar to that used in the tropadyne. However, note that in the Strobodyne no instrument such as a grid condenser or grid leak for detecting is employed.

AN IMPROVEMENT

After a great many tests the circuit shown in Fig. 4 was developed. The diagram shows the typical Wheatstone-bridge arrangement. The tuning and oscillating circuits, R and G, have been transposed, but this does not change the operation of the circuit. In this hook-up the center of the coil, M, is connected to the center of the capacity, C2; but, since it is not possible to get to the center of the dielectric

THE STROBODYNE CIRCUIT

BY arrangement with Lucien Chrétien, the inventor, all articles on this circuit for this country have been copyrighted by RADIO NEWS in the United States, and must not be republished without permission of the publishers.—EDITOR.

(unless a double condenser is used), a tap is made between two small capacities (C3 and C4), which may consist of a compensating condenser having one rotor and two stators. Since this capacity is in parallel with that of the variable condenser, it should be as small as possible, in order not to reduce the tuning range of C2.

This arrangement has the advantage that, if the point, M, is not exactly in the center of the coil, the circuit may be balanced by adjusting the compensating capacities, C3 and C4.

CONDITIONS REQUIRED FOR STABLE OPERATION

How should the Strobodyne tube work? During the half-cycles when the grid is positive the signal should be suppressed. Circuit R should be short-circuited by the low grid-filament resistance. This takes place with a fairly high potential on the grid; from which it follows that oscillations produced through the oscillating circuit, G, should be fairly strong. During the half cycles when the grid is negative the tube should amplify. This amplifying effect would be suppressed if the grid were made too negative (in which case the plate current would fall to zero) or even if the operating point were brought below the lower bend of the characteristic curve of the tube. It is therefore necessary that the amplitude of the local oscillations should be not too great.

These two conditions limit the amplitude of the oscillations, which control the sensitivity of the system. To adjust the amplitude of the generated oscillations we may, for instance, vary the plate voltage

or the coupling between the plate and grid coils of the oscillating circuit. In practice we have used both of these methods, as will be explained later.

OBTAINING SELECTIVITY

The main feature of all novelties is that there are always some surprises which spring up when least expected. This new circuit did not fail to conform to the rule and we found that, although the sensitivity was great, the selectivity was practically non-existent.

Condenser C2 would have barely any effect on the tuning. This was, of course, an unwelcome fact, but it tended to show how different the system is from the standard circuits. However, after looking it over, one may see that this lack of selectivity may be easily explained: the tuning circuit is practically short-circuited half the time and this damping effect is the cause of the very broad tuning.

To overcome these defects various methods could be used. For instance, a part only of the tuning circuit could be inserted in the common grid circuit (Fig. 5). The damping effect in this case varies with the autocoupling between the two circuits. However, if the tuning circuit were so connected, one might think that only part of the signal voltage would be applied to the grid of the tube; this, naturally, would be a waste of precious energy.

This would be true if there was a certain fixed amount, but since the voltage developed across the circuit depends upon its damping, it is evident that the less the damping produced by the local oscillations, the greater the signal voltage received. This is proved experimentally, because the circuit of Fig. 5 tunes sharper and the signals are louder than with that of Fig. 4. Before proceeding further, we may say that the arrangement of Fig. 5 is that used in the complete receiver. It allows the writer, who is located in Paris (France), to hear most of the European stations after four o'clock in the afternoon, using a loop only one foot square.

REMARKABLE SENSITIVITY

The secret of the great sensitiveness obtainable with this circuit lies, we believe, in the fact that the tube amplifies, while in standard superheterodynes the tube used as

(Continued on page 70)

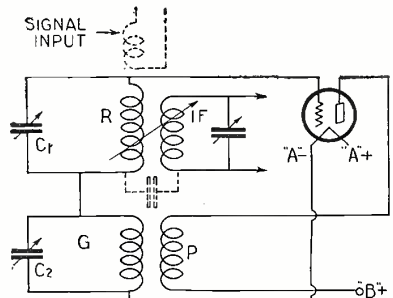

FIG. 3

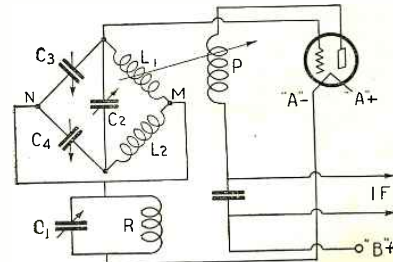

FIG. 4

By the circuit in Fig. 3 it can be shown there is neither modulation nor rectification in the tube. Fig. 4 shows a Wheatstone Bridge circuit incorporated in the hook-up.



\$100.00 PRIZE CONTEST



What Can You Do with Burnt-Out Vacuum Tubes?

SEVERAL years ago RADIO NEWS' sister publication, SCIENCE AND INVENTION, ran a prize contest entitled "What Can You Do With Burnt-Out Incandescent Lamps?" Hundreds of excellent suggestions were sent in to the editors, and the contest was a great success. Stimulated, very likely, by that idea, *Popular Wireless*, of London, published recently an article on ingenious uses for burnt-out vacuum tubes. Some of the suggestions given by the author, Mr. O. J. Rankin, are published here, for the benefit of the readers of RADIO NEWS.

The editors believe, however, that our American readers will know of many more ways to utilize burnt-out or old discarded tubes than those illustrated here. Accordingly, we are offering \$100.00 in prizes for the best suggestions; and we know we shall

\$100.00 Prize Contest

18 CASH PRIZES

First Prize	\$25.00
Second Prize	15.00
Third Prize	10.00
Fourth to Eighth Prizes, inclusive, at \$5.00 each.....	25.00
Ninth to Eighteenth Prizes, inclusive, at \$2.50 each.....	25.00
	\$100.00

erest, as well as the most useful suggestions concerning burnt-out or discarded vacuum tubes.

(9) From this contest are excluded all employees of the Experimenter Publishing Company and their relatives.

(10) In the event of a tie, two or more contestants submitting identical prize-winning entries, identical prizes will be awarded to those so tying for the prizes.

(11) This contest closes at noon August 20, 1927. Names of prize winners will be announced in our November issue.

(12) Descriptions should be not more than 200 words, typewritten or legibly written in ink on one side of the sheet only. Name and address of entrant should be printed on each sheet of entry.

(13) Models submitted in this contest must be very carefully packed to avoid breakage in transit. We cannot accept responsibility for loss or damage in the mails.

(14) Address all entries to Editor, Burnt-Out Vacuum Tube Contest, c/o RADIO NEWS, 230 Fifth Avenue, New York City.

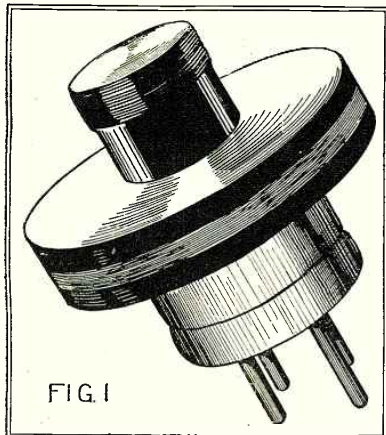

A R.F. transformer, mounted on a tube base.

be overwhelmed with discoveries of new uses to which burnt-out vacuum tubes can be put.

It is not necessary to send in the actual article; although the editors would like to see it, in order to judge the entry more intelligently than can be done by inspecting a sketch. Please note the following conditions:

RULES TO FOLLOW

(1) As many models as desired may be entered in this contest.

(2) If models are sent in, they must be carefully tagged with the name of the owner.

(3) When it is not practical to send the article itself, a good photograph (5x8 inches) should be taken, and a separate pen and ink sketch submitted as well.

(4) Each photograph and each sketch, also each page of description, must bear the entrant's name and address.

(5) Models will be returned as soon as the contest is closed.

(6) While the editors prefer the article itself, this is not essential for the acceptance of entry. Good pen and ink sketches will do, with the description.

(7) It is not necessary that the burnt-out vacuum tube be used for radio or electrical purposes. Any utilitarian, decorative, or other purpose to which the tube can be put will be eligible for consideration in this contest.

(8) Prizes will be awarded for the cleverest, as well as the most useful suggestions concerning burnt-out or discarded vacuum tubes.

or other it may prove to be a very useful gadget. It may be, to some, a painful reminder of a certain hectic moment, but the live experimenter does not regard it as a monument to his folly; he finds some practical use for it, and thus the tragic past is soon forgotten. There is something almost inhuman about the base of a broken tube; bury it amongst other debris in the scrap-box, and it will always come to the top, imploring you to make some further use of it. That new gadget of yours, and the problem of mounting it; glance in the direction of the tube base and you can almost see the four legs struggling in an effort to help you.

MANY DIFFERENT USES

I have discovered, from time to time,

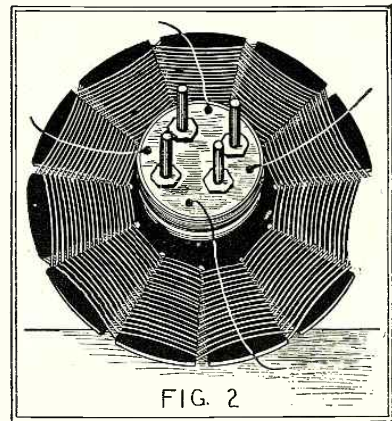

Method of bringing out the wires for transformer of Fig. 1.

UTILIZING BURNT-OUT TUBES

By O. J. RANKIN

THE base of a broken tube—a mere cap with four accurately spaced pins—is well worth saving, for at some time

many different uses for these idle legs, and for the benefit of all experimenters I present a selection of ideas which may be helpful. Owing to the liberal use of illustrations, details of the various devices are somewhat brief.

The idea, of course, is to make some useful component, utilizing all four pins, and mount it on the base so that it can be plugged into a standard socket. The first thing which suggests itself is an R.F. plug-in transformer; this may be wound on a grooved disc, on a slotted card, or arranged as two small basket coils. A piece of a bone knitting needle is threaded at both ends (with an adjustable die, taking at least six cuts) and screwed into the exact centre of the base to form a stud. The transformer is then clamped to the top of the cup by means of a knob (see Fig. 1), the ends of the windings being taken down inside the cup, passed through small holes in the base, and clamped firmly under the shoulders of the pins.

APERIODIC COUPLING

The method of bringing out the wires is shown in Fig. 2, where the cup is fitted with two closely coupled card inductances. Fig. 3 shows an aperiodic R.F. transformer, the resistance wire (one turn per meter of wavelength for both primary and secondary) being wound on a round wooden form, about 4 inches long, which is attached to the inside of the cup by means of wood screws. In this case the connections to the

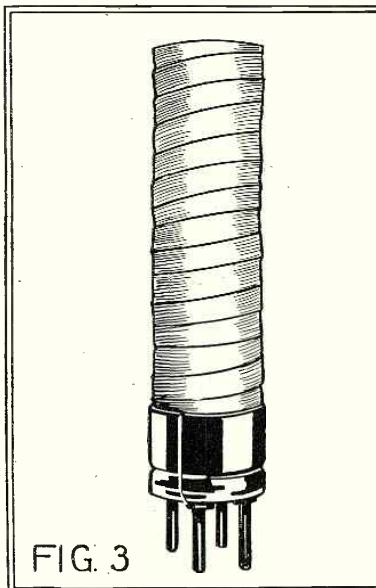

Another type of R.F. transformer.

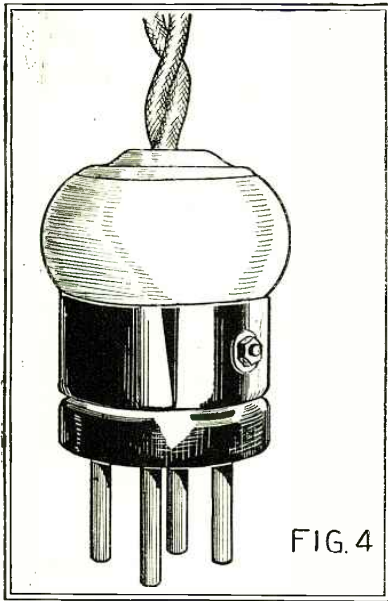

A switch made from a tube base and part of a lamp plug.

pins are, of course, brought down over the outside of the cup. Cover the winding with Empire tape. Connections are shown at A (Fig. 7).

A HANDY SWITCH

Switching arrangements are somewhat limited, owing to the fact that the pins can only be placed in one definite position. The examples shown may be found worth while. Connect the two filament pins together, also the plate and grid pins, and wire the holder as at B (Fig. 7). The result is a simple plug switch for controlling the "A" and "B" battery current. Connect the plate and grid pins together, join a length of twin insulated wires to the filament pins and connect the phones to the other end of the flex. Wire the holder as at C, and we get a combined 'phone plug and battery switch, the battery current being switched on simultaneously with the plugging in of the 'phones.

Take great care in making the connections, and use indicating tags as shown. To

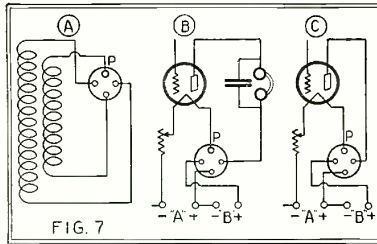

Circuits of a R.F. transformer and change switches, utilizing tube bases.

make a neat job pass a length of rubber tubing over the four leads. Fig. 4 shows the plug wired for this arrangement. The top portion is an ordinary hardwood lamp socket plug, minus pins and body, the threaded part being cut off and screwed to a wooden disc fitting the cup.

Another R.F. transformer is shown in Fig. 5; it consists of two large ebonite knobs, and a length of threaded bone rod,

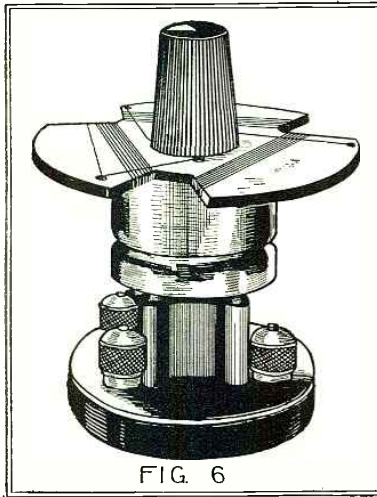

A triple resistor for a three-tube set.

one knob being drilled through the centre and driven on to the rod, and the other screwed firmly to one end of the rod so that

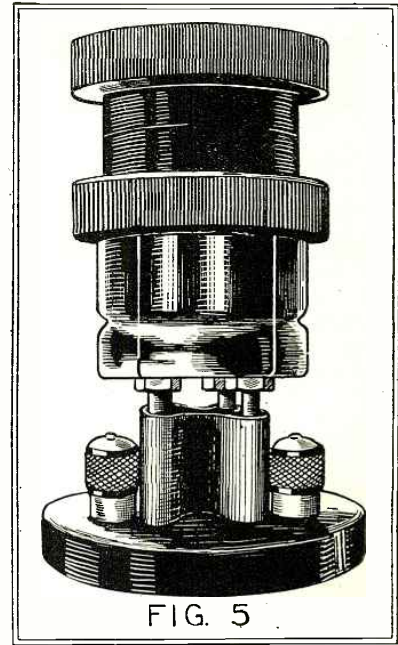

A R.F. transformer in which two bakelite knobs are used with a tube base.

both lugs meet. The other end of the rod is then screwed well into the base of the cup, and the ends of the windings connected as shown in Fig. 3. Should it be desired to pass the connecting wires down inside the cup, the two knobs must be otherwise attached, and the rod arranged as an independent stud.

A USEFUL RESISTOR

Fig. 6 is a side view of a triple resistor for a three-tube set, requiring all three resistances in the "A" circuit. The resistance wire is wound on a disc of sheet fiber, about 2½ inches in diameter and ¼-inch thick, in which three recesses have been cut, as may be seen. It is similarly drilled in the center for a threaded bone stud, and for small holes to pass the wire. A rough diagram of the pin connections should always be made, and kept as a wiring guide.

—Popular Wireless.

An Effective Method of Regeneration Control

By THOMAS L. MCKAY

THE application of regeneration in the proper place increases the sensitivity and volume of practically any set. The greatest difficulty in its use is its effective control. It is easy enough to apply an enormous amount of regeneration to the circuit, but the actual control should be simple to operate and should be non-critical.

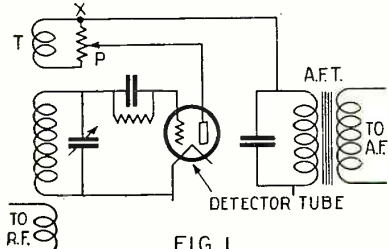

An easily-controlled method of regeneration which is uncritical.

Use of the rotary type of tickler enables the application of plenty of regeneration; but the setting of the tickler coil for any particular wavelength is usually very critical. Several of the condenser-coupled types of regeneration control are quite effective and some of these are not too critical to allow an easy adjustment.

USE OF A POTENTIOMETER

Fig. 1 shows the application of a system of regeneration control which is not critical and still allows any desired amount of regeneration. The tickler coil T is wound on the grid end of the last radio-frequency transformer, that connected just before the detector tube. This winding should be spaced about ¼-inch from the grid winding, and should contain about 10 to 15 turns of No. 24 double-silk-covered wire. The potentiometer, P, should have a resistance of 1,800 to 2,000 ohms. Its outside terminals are connected directly across the tickler coil,

while the arm is connected to the plate of the detector tube.

The lead to the secondary of the first audio transformer should be connected to one of the outside points of the potentiometer. In case the set does not regenerate, simply reverse the leads to the tickler.

(Continued on page 83)

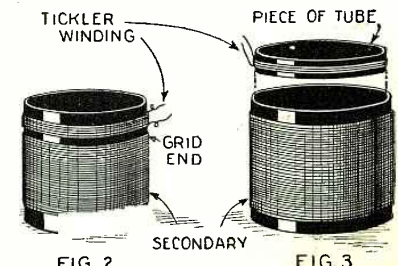

Showing the proper positions for the tickler coils.

Light-Sensitive Crystals

Some Suggestions for the Experimenter with Home-Made Photoelectric Cells

By G. C. B. ROWE

ONE of the most interesting fields for experimentation is light-sensitive cells. It has been thought heretofore that these cells were for the most part expensive and out of reach of the average experimenter. However, there are a number of cells that can be made and the experiments that can be performed with them are numerous.—EDITOR.

LATELY there has been shown a great deal of interest in photoelectric cells, due to the fact that television has been successfully demonstrated in this country, as described in the June issue of RADIO NEWS. Most of the apparatus employed in that demonstration is far beyond the reach of the average experimenter; yet there are several types of light-sensitive cells, which any interested amateur can make and with which he can perform experiments.

EARLY DISCOVERIES

As far back as 1839 Becquerel, a French chemist, discovered that an electric current passed between two silver plates coated with chloride of silver and immersed in dilute sulphuric acid, if one were exposed to sunlight. Later on, measurements of the intensity of light were made with standard photographic film, which depends for its sensitivity on silver salts. But the first real development of the possibilities of registering the impact of light came with the discovery of the photoelectric properties of selenium.

This element, which belongs chemically in the "sulphur group," was discovered in 1817 by the Swedish chemist Berzelius, while analyzing the material found in lead chambers used for the manufacture of sulphuric acid from pyrites. Because of its close resemblance to tellurium (named for the Earth, in Greek *Tellus*) he named it

selenium (from the Greek *Selene*, the Moon). It has a high resistance to electricity, falling with the temperature until it melts, when it suddenly becomes less conductive. In 1873 it was used by Willoughby Smith as a resistance medium in making measurements on telegraph cables; and the discovery was then made that the resistance of selenium, particularly in the "metallic" (crystalline) form, decreases very greatly under the influence of light.

This caused experiments on selenium itself, and Siemens found that the effect of light increases the conductivity of selenium as much as fifteen times. Bell, then developing the telephone, soon took advantage of the discoveries; and produced the "photophone" and later the "spectrophone." With the former he demonstrated in 1880 the transmission of speech over nearly 700 feet by means of a beam of light, modulated by the voice (it was reflected from a flexible diaphragm vibrated by speech), and received by a selenium cell in circuit with a telephone receiver.

The spectrophone was employed to test the effect of the different light bands in the visible spectrum, and in the ultra-violet and infra-red regions beyond (see RADIO NEWS for June, page 1422). Bell found the latter most sensitive, but obtained negative results in the further portion of the visible violet. It was also found that other materials, such as lampblack, are photoelectric; but until the recent discoveries of electron emission, selenium remained the most generally-used substance for work of this kind. It is not, however, the only one, as this article will explain; and the experimenter can readily construct a cell which will respond electrically to the influence of light, as shown by a galvanometer, or an amplifying circuit with phones.

Selenium which can be made into an efficient photoelectric cell is not very difficult to procure, but the process of making one of these cells from the element is one in which a great amount of care must be taken. On the other hand, for the experimenter who wishes to try his luck with light-sensitive crystals, there are a number of substitutes with which to work.

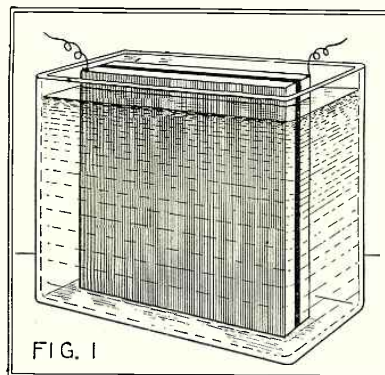

FIG. 1
Two metallic plates, separated by an insulator, and immersed in a metallic-salt solution, will assume light-sensitive properties in about a week.

A SIMPLE CELL

If two similar metallic sheets, separated from one another by a thin sheet of some insulating material (such as bakelite, mica, etc.) are allowed to remain in a solution of a salt of the metal for a few days, in the dark, the metallic surfaces will develop light-sensitive properties. For example, take two small sheets of any common metal, such as copper, iron or zinc, having between them one of the insulators mentioned above, and tie them tightly together with string. Place this bundle in a glass container in which there is a weak solution of a metallic salt of the same metal of which the sheets are composed. That is, if copper has been used, the solution should be a weak one of copper sulphate or any other copper salt. If zinc sheets have been selected, zinc sulphate can be used. The sheets are allowed to remain undisturbed in this solution, in a dark place, for at least a week. After this time the surface of the sheets will have become sensitive to light and experiments thereafter should be conducted in a darkened room.

Fig. 1 shows an apparatus consisting of two metal plates, with an insulating separator, immersed in a metallic-salt solution. If a beam of light from an ordinary electric lamp, or in some cases even an oil lamp, is permitted to fall on the surface of the cell, a current will be indicated on a galvanometer which is in series with the two plates. Moreover, the flow of current can be maintained for quite an appreciable length of time before the cell becomes "fatigued."

Here we are dealing with the phenomenon connected with the light-sensitivity of certain crystals. During the time that the metallic sheets are in the solution, a microscopic crystalline deposit is formed on them; and it is to the minute particles in this crust that these properties of light sensitivity are due.

Certain natural crystals also possess light-sensitive properties. It has been found that the mineral with the greatest sensitivity to light is *argentite*, a native sulphide of silver. Unfortunately, this mineral is very rare and so are most of the other ones which have this property in which we are interested.

A MOLYBDENITE CELL

However, the mineral crystal *molybdenite* has been found to act as a quite efficient converter of light into electrical energy.

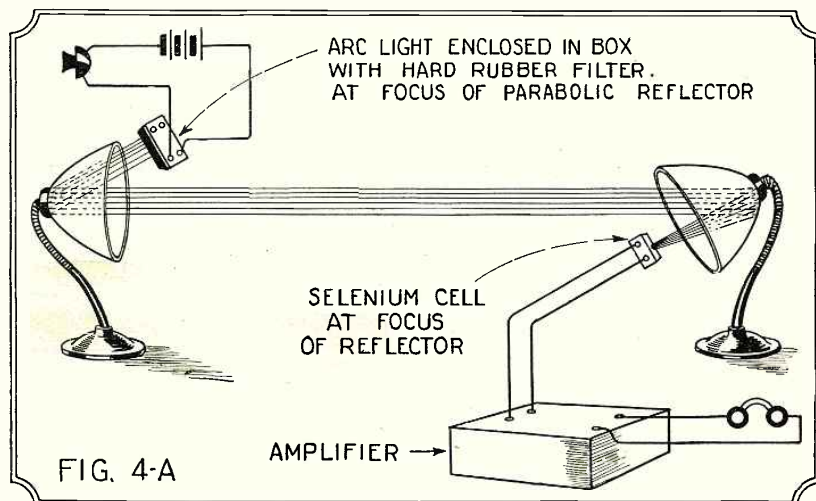

Diagram of connections for a "talking" light-beam. It is important that the arc and the cell be at the foci of the reflectors. It is there that the rays are concentrated.

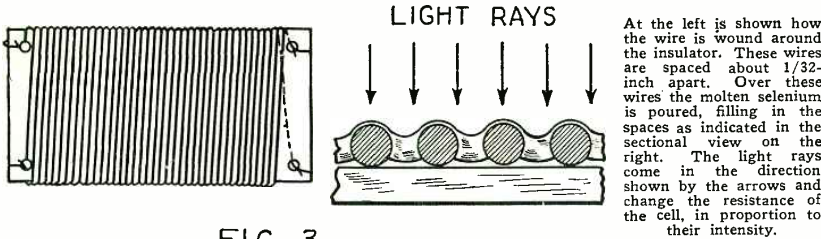

FIG. 3

This mineral can be obtained from chemical firms at a relatively small cost. In appearance molybdenite is rather like galena, with which almost every radio experimenter is familiar. Unlike the latter, though, molybdenite generally takes the form of flat plates, which can be peeled like mica.

The construction of a molybdenite cell is far from difficult and the results possible are satisfactory. Two thin plates of glass of the type employed in microscopes, one by three inches, are used. One of these slides is covered with black paper, such as photographic plates or films are wrapped in, and in which a slit about $\frac{1}{8}$ inch wide is cut in the middle of the paper (see Fig. 2). A sheet of molybdenite, having a wire connected to each end of the mineral, is then placed on the other glass slide. The two slides are then bound together tightly with string.

If the leads from such a cell are connected to a microammeter or a sensitive galvanometer and a light is held before the narrow slit in the black paper, a reading should be indicated on the meter, showing that the crystal has generated an electric current under the influence of the light rays. An oil lamp will produce readings of the order of 2 to 7 microamperes. If greater currents are desired, more powerful lights are needed; one of the most powerful being obtained by burning magnesium ribbon before the slit.

It might be well to bring up here the point that, unless an extremely sensitive meter is employed, unsatisfactory results will be obtained. When dealing with such minute current as a few microamperes, it is easily seen that the ordinary milliammeter will not suffice. However, if the experimenter wishes to go a little further, he can build a vacuum-tube amplifier which will step up these small currents so that greater readings are obtained on the indicating device.

CONSTRUCTION OF A SELENIUM CELL

A selenium cell is a bit more difficult to construct than the cells already mentioned. However, as selenium may be obtained from chemical firms at a comparatively small cost and as the experiments which can be performed with it are very interesting and varied, the details for building such a cell are included here.

There are many different types of cells using this element, but the one named after the man who developed it, is the Bildwell cell, perhaps the best-known one. It is made by winding on a sheet of slate or mica two bare wires of copper, brass, German silver or platinum, spaced about $\frac{1}{32}$ inch apart. The insulator should be about one by two inches, and for a plate of this size No. 28 wire will be found convenient (see Fig. 3).

The selenium is applied to the form by melting it over the wires, and this is the point where a great deal of care must be exercised. The best way of getting the selenium on properly is to place the wire-wound mica on a mica-covered copper plate supported over a bunsen burner. The temperature of the cell is raised to the point where a stick of selenium (which looks like black sealing-wax) melts, when touched to the surface. The entire surface of the cell

is coated with the selenium in a very thin layer, smoothing out the lumps with a steel knife or a stiff sheet of mica. The temperature of the burner is very important. If this is too low, the selenium turns gray and added heat is necessary to melt it; while if it is too high the selenium collects in drops caused by surface tension and is as difficult to spread as mercury. The proper state is a semi-fluid condition which it attains at 220° C. (428° F.), when it can be easily handled.

When a satisfactory surface has been obtained the cell is transferred to a copper plate to cool while the bunsen burner is turned down to give a temperature of 120° C. (248° F.). When cool the cell is replaced on the hot copper plate and heated again. In a little while the entire surface will turn gray, indicating the crystallization



BLACK PAPER WITH $\frac{1}{8}$ " SLIT

FIG. 2

This shows the position of the slit in the black paper for a molybdenite cell.

of the selenium. The temperature is slowly increased until the selenium shows signs of melting, which will be indicated by the edges turning black. The burner is at once removed and the edges allowed to recrystallize. The burner is then turned down a trifle and replaced under the hot plate. The cell must be watched carefully for signs of melting and, if none appear, it is allowed to stand over the heat for three or four hours. The temperature of the burner should be so adjusted that it is just under the melting point of the selenium. The cell

is cooled off by turning the burner lower and lower for the period of about an hour. This method of gradual heating and cooling is called annealing.

The cell, when cooled, is ready for mounting. The usual method is to place the cell in a small wooden box in which there is a glass window admitting the light; leads from the electrodes being connected to two binding posts on the box. This will protect the cell from dust and moisture. The main thing to remember is to get a layer of selenium as thin as possible over the wires.

APPLICATIONS

Numerous applications to which this cell can be adapted are within the realm of the experimenter, but there is space here for only a few. One of the uses for a light-sensitive cell is as an indicator of fire. A very simple alarm can be made by putting on a cheap voltmeter two contacts at points on the scale which will be the positions of the needle when the light is off and on the cell. It might be said here that the resistance of the cell varies *inversely* as the amount of light falling upon it; i. e., the more light, the lower the resistance.

Such a device can be easily constructed and the current consumption will be very small. A voltmeter is connected across the cell when there is no light shining upon the latter; that is, when the resistance of the cell is high. This point is noted, and also the lower point of the reading when light is directed upon the cell. The needle can be made to close an electrical circuit in which there is some sort of an alarm when it is at this lower point.

The same principle can be applied to many different types of simply-made apparatus. For instance, the filament-circuit switch of a radio receiver could be connected to one of the contacts mentioned above and the turning on of the light in a room would be sufficient to switch on the set. Selenium cells have long been used to light lamps, as, for instance, in a lighthouse, when it becomes dark. Many other unique applications will doubtless suggest themselves to the experimenter.

TALKING OVER LIGHT RAYS

Another interesting experiment, which may be made with the use of a selenium cell, is talking over a light ray. This has been done in many different ways heretofore, but the simplest is to construct an electric-light circuit to which is inductively coupled a microphone. This light is directed by a parabolic reflector, which projects par-

(Continued on page 77)

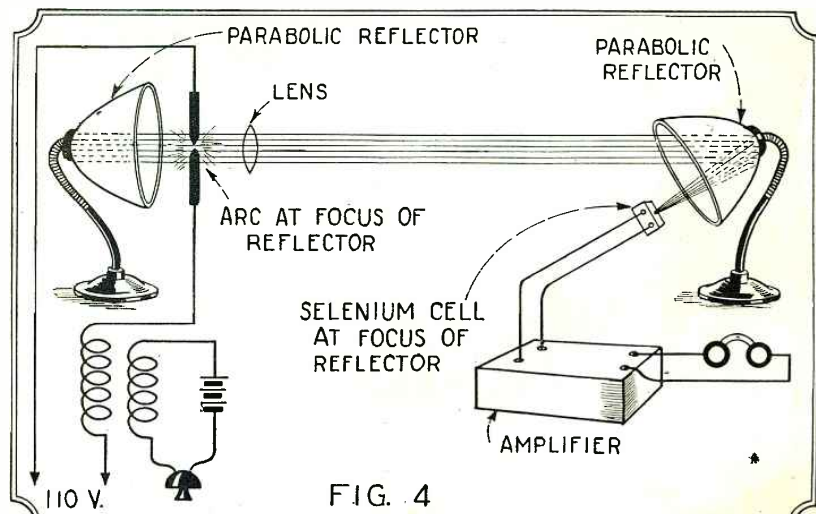

FIG. 4

By enclosing the source of light (whether arc or powerful lamp) behind a suitable filter, infra-red rays may be separated and used as a means of invisible communication, as shown above.

An 18- to 1500-Meter Receiver*

Description of an Easily-Constructed Set with Plug-In Coils

By L. W. HATRY

THE amateur set constructor who can read radio code will find this receiver a most delightful one to operate. If he is listening to broadcast music and suddenly feels the urge to hear amateur or ship stations, he can satisfy the feeling instantly by merely lifting out one coil and replacing it by another. He can cover the whole sweep of wavelengths from 18 to 1,500 meters in this manner and is certain of finding something interesting to listen to. The receiver is extremely sensitive on the broadcast band, and will bring in many distant stations without trouble. It is just the thing for the man who wants one set and no more.—EDITOR.

THE plug-in coil idea, which assumed importance with the birth several years ago of the "honey-comb" type of coil-winding, has proved the most satisfactory solution of the problem of constructing a general-purpose radio receiver covering a great frequency range. For such a set, in which the several circuits—antenna, grid and plate,—require individual windings, it is desirable, if convenience is to be considered, that these three be on a single plug-in form.

In the set constructed by the writer and illustrated here, the coil forms have six contacts and are designed to fit a keyed circular socket with six spring contacts. The keying makes certain that the coil-form will fit the socket in only one way. With these six contacts and a little ingenuity it is possible to devise upwards of twenty-five different coil arrangements for different purposes.

The circuit used is conventional. For the

shorter wavelengths, below 200 meters, it is the well-known one of Fig. 1; and, for those which are longer, it is the equally well-known one of Fig. 2. A very slight difference exists due to the presence of the condenser C1, which is not used with the primary coil (L1). The primary is on, or rather in, the coil-form for the higher waves and plugs into the circuit automatically when the proper coil is used. The short-wave forms carry only two windings: secondary and tickler (L2 and L3).

The complete circuit, including the audio amplifier, is shown schematically in Fig. 3.

CHOICE OF CONDENSERS

To avoid multiplicity of coils and to provide overlap of the tuning ranges, the author has chosen for these standard coil units a tuning condenser of .00014-microfarad maximum, with a minimum in the order of .000015 microfarad. This value of the minimum is due partly to the tube and its associated wiring. This condenser value is suitable for the higher frequencies, represented by waves of 200 meters and less. A higher maximum capacity and greater capacity range is needed to tune to the lower frequencies (higher wavelengths). For the wavelengths above 200 meters the coils are designed for use with .00035-mf. as the maximum capacity, with practically the same minimum as before. To get these two capacity ranges, necessary to cover the waves from 18 to 1,500 meters, a simple switch and a series-condenser arrangement is used in conjunction with a standard .00035-mf. (maximum) variable condenser.

A straight-line-frequency variable condenser is desirable for two reasons; it makes tuning easy and accurate, and it conforms with logic. One is necessary in an arrangement such as that used in this set, since a series capacity enters into the design considerations. In Fig. 4 are shown several curves, all plotted against frequency and

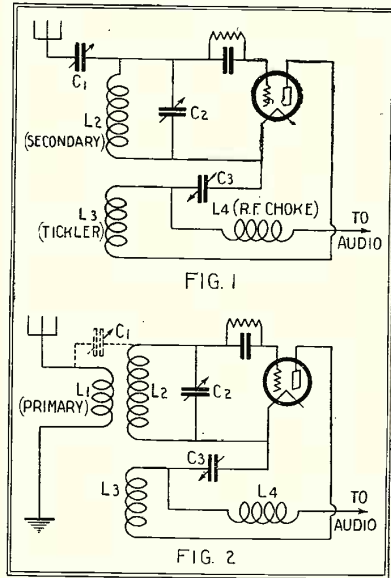

In Fig. 1 is shown the receiving circuit used for short waves, and in Fig. 2 that for wavelengths up to 1,500 meters.

dial-settings; the usual arbitrary 100-division, half-circle range being considered as standard. Curve "C" is that of a variable condenser with semi-circular plates, whose curve of capacity-increase against dial settings is a straight line. The curve "C" shows how badly the frequencies at the lower dial settings are crowded and how they are spread out at the higher.

If it is desirable to make the tuning curve plotted in Fig. 4 straight, both "C" and "B" would be unsatisfactory. Curve "B" indicates the need for a condenser whose plate design will give nearer a straight-frequency line. Curve "A" is a straight-frequency line such as would result from the use of the proper variable condenser, and "D" shows the alteration in the same curve resulting from the use of a series capacity. For tuning convenience it is decidedly inadvisable that the tuning condenser (C2) used in Fig. 3 be other than one whose plate-design is intended to give a straight-frequency-line. Of course, if the "curve" is not straight, the electrical efficiency of the set will not be altered, but the tuning convenience will.

The detector-tube socket is on the underside of the coil-socket shelf, to assure short leads and the consequent wiring simplicity that results. The coil-socket shelf is of decided utility; the coil socket is thus located where one can put in the coil without hunting behind the panel and without rising, if one is sitting before the set. The detector tube hangs nose down.

The back edge of the coil-socket shelf, as shown, is supported by a plain stick of wood, which may be a length of half-inch dowel stick.

SMALL-CAPACITY GRID CONDENSER

After several comparative tests the writer has for a long time used a .00005-mf. grid condenser in his broadcast receiver; it does not, apparently, reduce volume sufficiently to bother the ear, and the improvement in quality is evident.

This set, tuning down to 18 meters, could afford a smaller grid condenser at the short-

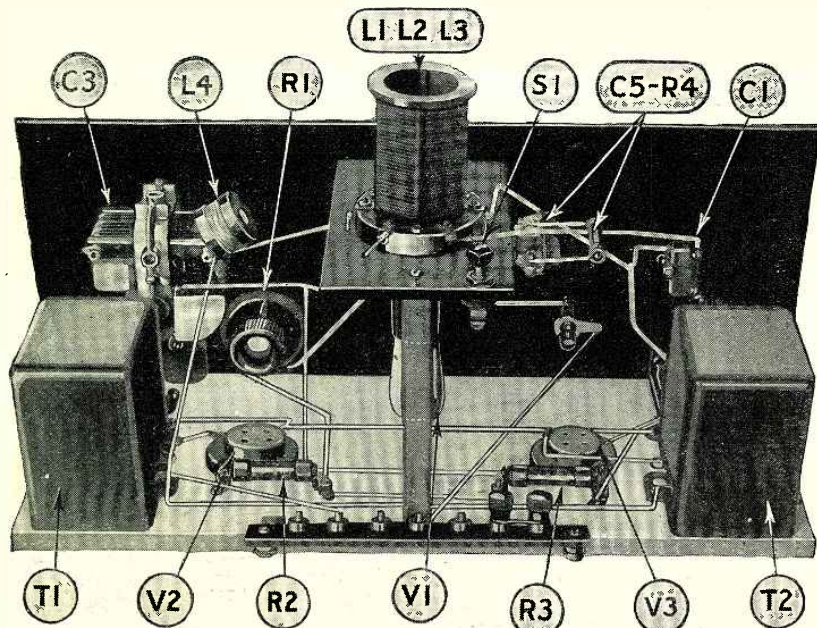

L1, L2 and L3, plug-in inductor; C1, midget condenser; C3, variable condenser; C5, grid condenser; R1, 60-ohm rheostat; R2 and R3, ballast resistors; L4, R.F. choke; R4, grid-leak; S1, wave-changing switch.

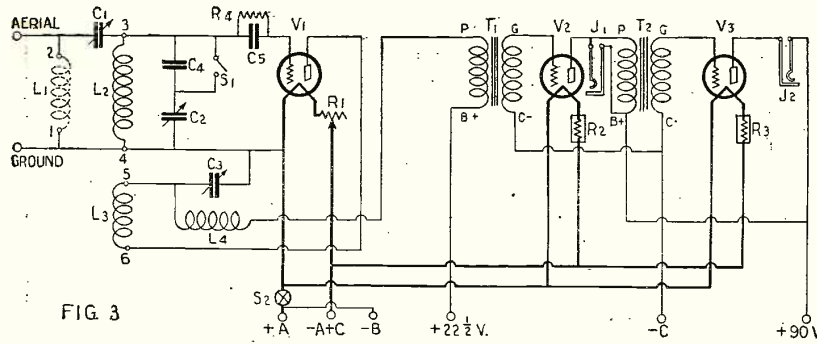

FIG. 3

The schematic diagram of the 18-1500 meter receiver. The switch, S1, is used for shorting the condenser, C4. It is left open on the short waves, and closed for the high.

For instance, the 18-meter minimum is a trifle high, although not much lower may be obtained.

The utility of the double capacity range is obvious. With the switch, S1 (Fig. 3) open, the tuning capacity maximum (C2 and C4 in series) is .00014-mf.; any wavelength range in the .00014-mf. column (table) with the correct coil, can be obtained. With the same coil, and the switch closed, the wavelength range is extended to that obtained from the .00035-mf. maximum. When using the 18-meter coil, in other words, it is possible to chase up to 40 meters quickly to see if anything is going on, by merely closing the switch and without changing coils. Tuning will be easier and signal strength slightly better when the proper coil and capacity for the proper wavelength ranges are used, however.

A feature to interest the 600-meter commercial man, it seems to me, is the largest coil and its 490-900-meter wavelength range, with .00014-mf.; because with this coil and capacity values, he can cover the entire useful 600-traffic zone with nicely spread-out tuning. I have enjoyed tuning up there on that account.

The R.F. choke coil is not a small choke; it is one-millihenry and the style specified for wavelengths on the order of 2000 meters. With capacity regeneration control such a



The small letters at the ends of the wires coincide with those shown at the ends of the loose wires on the picture diagram found on page 35. The tube socket V1 is screwed bottom up to the under side of the sub-panel. Its four posts are lettered F. F. G. P.

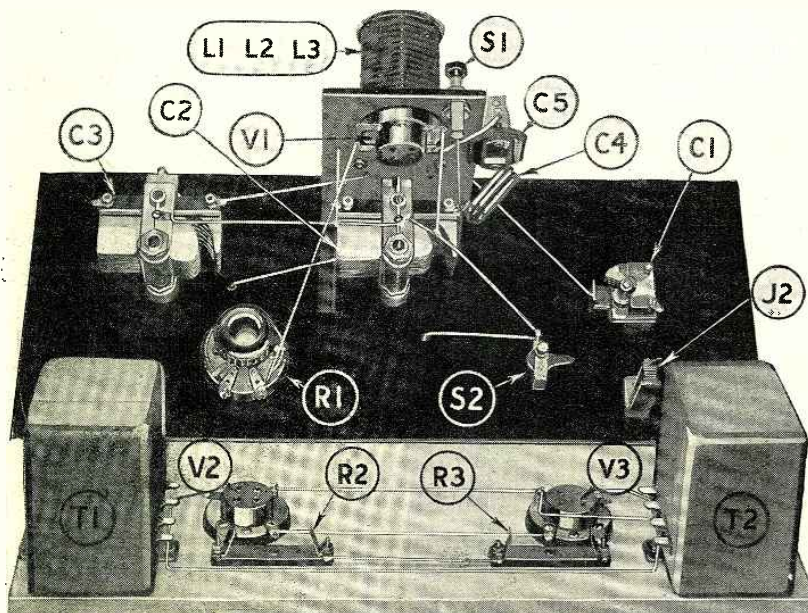
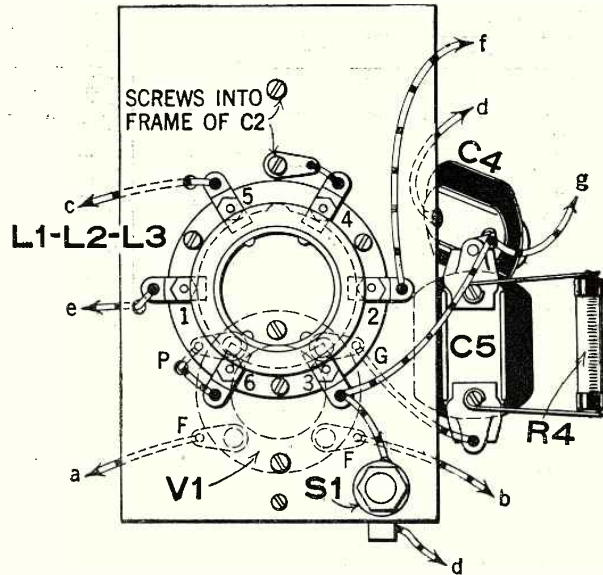

C2, variable condenser; S2, battery switch; T1 and T2, A.F. transformers; J2, jack. The rest of the apparatus is numbered as in the other illustrations. The set is shown here half assembled.

choke is necessary generally to insure good results. Otherwise the tube oscillates continuously on wavelengths from 200 to 1,500 meters when the ticklers are of the right size to cover the range. This seems to me, after check-up with small and large audio transformers, to be due to the distributed capacity of the A.F.T. primary, which takes effect and nullifies the use of the variable condenser which is the controller of regeneration. When the choke is put in oscillation stops immediately (if the control condenser is set to minimum) and starts up under control of this condenser, C3. No R.F. choke is needed between 200 and 18 meters; the primary of the A.F.T. seems to offer enough opposition.

OBTAINING BEST RESULTS

After having carefully picked out a fairly respectable, non-distorting size of grid condenser and its shunt resistance, it would be silly for the constructor to put poor audio

transformers in this little set. For broadcast reception high-grade transformers are necessary. For telegraph reception it is equally important; for many of the amateur C.W. tones are A.C. at frequencies between 32 and 240 cycles, all of which are out of the reach of poor audio transformers whose amplifying effectiveness is gone at 250 cycles or whose optimum range is limited definitely between 400 to 1000 cycles. Both the short-wave fan and the broadcast fan want a transformer whose amplifying ability is good all the way down to 60 cycles. The only person who could be served by a transformer amplifying best between 400 and 1000 cycles is the commercial operator on shipboard, who uses 500-cycle tones most often. The utility of a selective audio amplifier on 600 meters is high. But on a set covering such a very broad band of wavelengths, and intended for so many purposes as this 18- to 1,500-meter outfit, good audio transformers are desirable.

The tuning of the set is not difficult. The midget condenser, C1, is set over to the left, or minimum, before starting up with the short-wave coils. Then the filament rheostat and the regeneration control tell one how the detector is operating for regeneration. After that an adjustment of the midget to permit fair regeneration control and good signal strength leaves the rest of the adjustments up to the tuning dial and the regeneration control. When the two coils having primary windings are plugged in, the midget is left at minimum setting and the angle of the primary winding is adjusted to give fair volume and selectivity, and

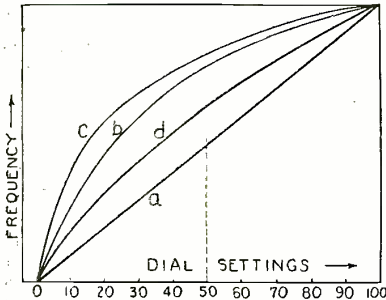

FIG. 4

A family of curves: (a) S.L.F. condenser. Half the frequency range is confined, to half the scale, causing even frequency tuning. (b) S.L.W. condenser. Two-thirds of the frequency range is confined below 50 on the dial, and only one-third shows in the upper half of the scale. (c) S.L.C. condenser (old-style semi-circular plates). Four-fifths of tuning range is confined to lower half of dial. (d) S.L.F. with series condenser, showing how curve (a) is altered to crowd a somewhat higher percentage of the tuning range below 50 on the dial. This effect would be worse if the alteration occurred in the (b) or (c) curve.

left there. The set is regenerative and tunes like others of the class.

At wavelengths below the broadcast band, reception of amateurs all over the world is its regular performance, for the writer, living in Hartford, Conn. He has heard South Africa, England, France, Germany, Italy, Australia and New Zealand, and thus it goes. In the broadcast band the set is a three-tuber, and no imagination can make it otherwise. For ship traffic it is especially good, and the writer enjoys listening to the crisp cross-talk a great deal. Ships are heard on both coasts and far off into the Gulf of Mexico.

(The layout for drilling the panel will be found on page 64.)

SYMBOL	Quantity	NAME OF PART	REMARKS	MANUFACTURER *
L1, L2, L3	4	Plug-in coils	Wavelength range 18-150 meters with	1
L1, L2, L3	1	Plug-in coil	Wavelength range 150-350 meters (.00014	1
L1, L2, L3	1	Plug-in coil	Wavelength range 450-900 meters mf.	1
C2, C3	2	Variable condensers	0.00035 mf.	1 11, 12, 13, 14, 15, 16, 17, 18, 19, 20, 43
T1, T2	2	A. F. transformers		1 4, 17, 21, 22, 23, 24, 25, 26, 54
S1, S2	2	Battery switches		2 15, 23, 27, 28, 29, 30, 31, 54, 54
	3	Tube sockets	IX 199 type	1 4, 13, 16, 17, 21, 28, 29, 32, 33, 34
C1	1	Variable condenser	Midget .000025 mf. or smaller	1 11, 19, 57
L4	1	R. F. choke coil	1 millihenry	1 7, 14, 16, 17, 24, 30, 26, 37, 38, 39
R1	1	Rheostat	60 ohms	2 4, 29, 23, 31, 33, 11, 42, 43, 56
C5	1	Grid Condenser	.00005 mf. or .0001 mf.	3 2, 28, 26, 39, 10, 44, 45, 46
C4	1	Fixed condenser	.00025 mf.	3 2, 28, 26, 39, 40, 44, 45, 46
R4	1	Grid leak	2 megohms	2 10, 23, 43, 44, 46, 47, 48, 49, 56, 58
J1, J2	2	Jacks	open circuit	4 2, 13, 19, 23, 26, 29, 30, 31, 47
R2, R3	2	Ballast Resistors	for 199 tubes	5 55, 56
	1	Vernier Dial		6 7, 8, 17, 21, 22, 24, 32, 34, 47
	1	Binding Post Strip	1" X 7" X 1/8"	7 34, 48, 50, 53
	8	Binding Posts		8 7, 34, 43, 53, 54
	1	Panel	7" X 18" X 3/16"	7 34, 48, 50
	1	Baseboard	wood 6 1/2" X 17" X 1/2"	7 34, 48, 50
	1	Coil Shelf	6" X 3 1/2" X 3/16"	7 34, 48, 50
V1, V2, V3	3	Vacuum Tubes	199 type	9 51, 52

NUMBERS IN LAST COLUMN REFER TO CODE NUMBERS BELOW.

1 Silver-Marshall, Inc.	2 Electrad, Inc.	3 Sangamo Electric Co.
4 Patent Electric Co.	5 Radiall Company (Amprite)	6 National Company
7 Micarta Fabricators, Inc.	8 H. H. Eby Mfg. Co.	9 C. F. Mfg. Co.
10 Daven Radio Corp.	11 Hammarlund Mfg. Co.	12 Hartman Mfg. Co.
13 Alton Mfg. Co. (Na-Aid)	14 Ambassador Sales Co. Inc.	15 Walbert Mfg. Co.
16 Gray & Denison Mfg. Co. (Remier)	17 All American Radio Co.	18 Wirt Co.
19 Chelton Elec. Co.	20 Radio Condenser Co.	21 Brewer-Tully Mfg. Co.
22 Bruno Radio Corp.	23 Federal Radio Corp.	24 Samson Elec. Co.
25 High Frequency Labs.	26 Stromberg-Carlson Tel. Mfg. Co.	27 Bryant Elec. Co.
28 Outler-Hemmer Mfg. Co.	29 Saturn Mfg. & Sales Co. Inc.	30 Millimeter Machine Works, Inc.
31 H. H. Frost, Inc.	32 General Industries Co.	33 Kleonar Radio Corp.
34 F. W. Morse Co.	35 F. W. Sibley Co.	36 Ma-Red Radio Corp.
37 General Wiring Co.	38 Globe Radio Equipment Co.	39 Radio Receptor Co.
40 Kellogg Switchboard & Supply Co.	41 Central Radio Labs.	42 General Instrument Corp.
43 Amaco Products, Inc.	44 Miscold Radio Corp.	45 Toho-Deutschmann Co.
46 Dubilier Condenser Corp.	47 Martin-Copeland Co. (Mar-Co)	48 Steintec Laboratories
49 International Res. Co. Inc. (Durham)	50 American Hard Rubber Co. (Radion)	51 Northern Mfg. Co.
52 Schleierling Products Corp.	53 X.L. Radio Labs.	54 Conn. Tel. & Elec. Co.
55 Langwin-Kaufman Mfg. Co.	56 E. S. Brach Mfg. Co.	57 General Radio Co.
58 Allen Bradley Co.		

* THE FIGURES IN THE FIRST COLUMN OF MANUFACTURERS INDICATE THE MAKERS OF THE PARTS USED IN THE ORIGINAL EQUIPMENT DESCRIBED HERE.

If you use alternate parts instead of those listed in the first column of manufacturers, be careful to allow for any possible difference in size from those originally used in laying out and drilling the panel and sub-base.

HOW THE MOTOR PATROL WARS WITH BLOOPERS

British Government Car Built to Fight Radiating Sets



THE motor equipment here illustrated was built for the use of the British post office, which has jurisdiction over radio, as well as all telephone and telegraph service in the United Kingdom; and is now being utilized to detect oscillating sets, which are prohibited by law.

Whenever a report is received that such a set is causing trouble in a neighborhood, the car with its crew of two operators and a driver is dispatched to the seat of the trouble. The house from which the trouble is emanat-

ing is quickly identified. An investigation is made of the sets, and the owner of the cause of the offense is informed of the trouble, and of the measures to be used to correct it. Should he fail to do so he is subject to revocation of his license and to a fine.

As will be seen by the illustration, a double loop is mounted on the top of the car, and one operator rotates it by the use of a hand-wheel, while the other observes the signal strength on a sensitive 3-tube set and notes the variation. In the vicinity of an oscillating set, the loop clearly indicates its direction; and a galvanometer shows the signal strength and the effect of interference. Even a movement of a yard creates a visible effect. It is thus possible to locate exactly the nuisance.



Above, at left, one of the operators of the British Post Office's detective car, taking the bearings of an oscillating radio receiver; at right, another adjusting the loop aerial on the car's roof before starting out.

Wide World Photos.

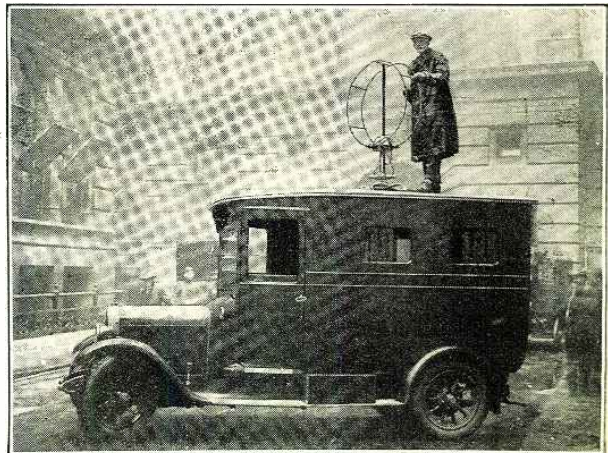

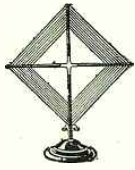

The Acme "D" Coil Receiver*

Combination of Tuned and Untuned R. F. Amplification Works with Loop Aerial

By JOSEPH RILEY

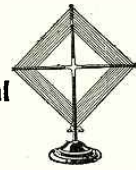

WE can especially recommend the "D" coil receiver to our readers, because it is easy to build and because the results it gives are so satisfactory. No problem of balancing or neutralizing enters into its electrical adjustment; the special construction of the "D" coil, and the use of two fixed R.F. transformers obviate the necessity for critical and uncertain balancing circuits. The quality of reproduction is of the highest order, and will satisfy the musically-inclined listener.—EDITOR.

IN this six-tube receiver, designed to cover the broadcast wavelength band from 200 to 550 meters, an unusual combination of tuned- and untuned-radio-frequency amplification is used. A total of three stages of R.F. is employed, the first two being the tuned ones. The coupling devices between the second and third tubes and the third and fourth (the detector) are two special fixed R.F. transformers, whose frequency-response curves overlap in such a manner that the instruments provide acceptably uniform coupling over the specified wavelength range.

The R.F. coupler between the first and second tubes is a special variable inductor, known as a "D" coil because of the shape of its windings. The latter are impressed in flat molded bakelite forms, one of which is fixed on a frame; the other turns directly against it through a half circle. The instrument is attached to, or rather is part of a special variable condenser. The construction is such that the coupling between the rotor and stator coils increases as the condenser capacity is increased, the rate of increase being so adjusted that the maximum interstage coupling, and therefore the greatest signal strength, is obtained at all times.

In the various accompanying illustrations this coil-condenser unit can be seen occupying the left section of the receiver, the coil being marked L and the condenser C. The condenser itself is of the straight-line-wavelength type, enclosed in a case to protect it from dust.

The "D" coil receiver is sufficiently sensitive to allow the use of a convenient loop

aerial. This device enhances the selectivity of the set, because of its directional properties. It also increases the signal-static ratio, a feature which especially recommends the receiver for summer use.

ELEMENTS OF THE CIRCUIT

The schematic wiring diagram reveals the exact electrical nature of the set: The loop aerial is connected directly across the grid circuit of the first tube, V, and tuned by the variable condenser C, which is part of the L-C combination. The "D" coil is placed between the first tube V and the second, V1, one set of windings acting as primary and the other as secondary. The secondary portion, it should be noted particu-

larly, and one resistance-capacity with impedance leak. An impedance instead of a resistor is provided in this last position to prevent the "motor-boating" trouble common to so many amplifiers of this type when they are operated with "B" socket-power devices.

The resistors R4 and R5 and the condenser C4 are one unit, the resistor clips being fastened directly to the body of the condenser and insulated in the proper manner. Likewise, the coupling components between the last two tubes are contained in one case, the instrument being marked T1. In appearance it is very much like the transformer T.

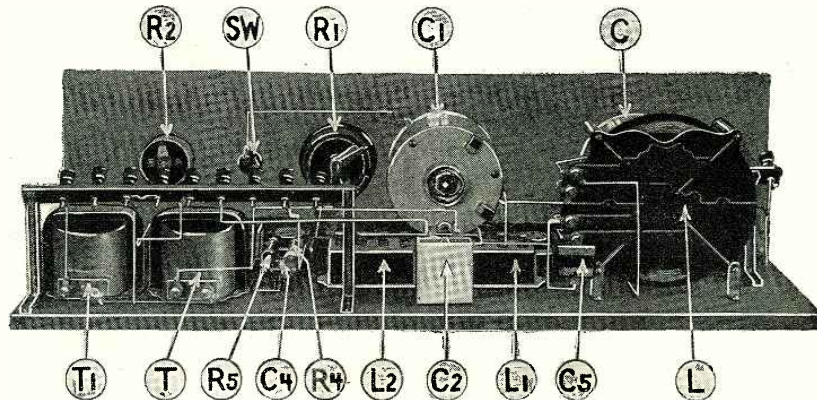

Back view of the receiver. The variable inductor L hides the variable condenser C, to whose end it is attached. R1 is the combination rheostat-potentiometer, R2 the rheostat which controls the current to the filament of the last tube. This illustration shows how the binding-post strip at the left is raised above the tops of the transformer T and the resistance-capacity-impedance unit T1.

larly, is tuned by a separate variable condenser, C1, which is mounted on the front panel to the right of the L-C unit. The "D" coil is *not* tuned by the variable condenser to which it is attached, the purpose of the mechanical combination being to provide an automatic variation of the V-V1 interstage coupling.

The fixed R.F. transformers are designated as L1 and L2, and are wired simply between V1 and V2, and V2 and V3.

The detector is not regenerative. It feeds into a three-stage audio-frequency amplifier consisting of one stage of straight resistance-capacity coupled, one straight trans-

former, and one resistance-capacity with impedance leak. An impedance instead of a resistor is provided in this last position to prevent the "motor-boating" trouble common to so many amplifiers of this type when they are operated with "B" socket-power devices.

PROCEDURE OF ASSEMBLY

Mechanically, the "D" coil receiver presents no particular problem to the radio fan of average constructional ability. The L-C tuning unit, the variable condenser C1, the rheostat-potentiometer R1, the battery switch SW and the rheostat R2 (for the last audio amplifier tube) are mounted on a front panel 7x26x $\frac{1}{8}$ -inch, in the positions shown in the accompanying scaled drawing. The other components are placed on a mahogany (or other wood) baseboard eight inches wide, a half inch thick and one inch shorter than the front panel, or 25 inches long. The front panel is screwed against its edge by means of four nickel-plated, round-head wood screws.

In assembling this receiver, mark out the front panel first, drill it, and mount the aforementioned parts on it. Now screw it to the baseboard temporarily, with one or two screws, and lay out the tube sockets, transformers, binding posts, etc., on the baseboard. Mark their positions with a pencil; then remove the front panel and screw everything down. Use ordinary round-head screws for this work.

No detailed dimensioned layout of the

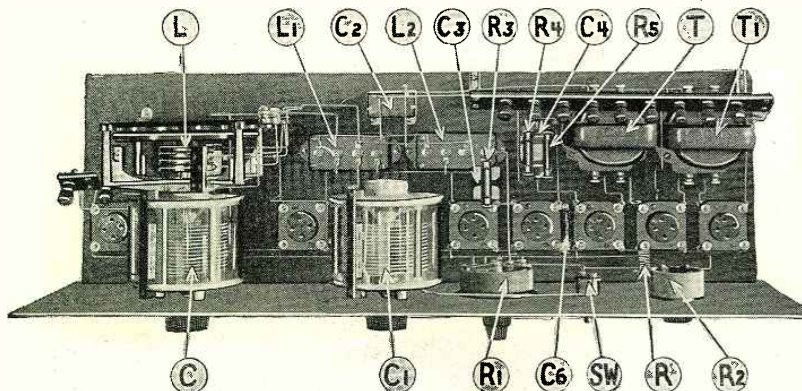

Top view of the set, showing how the parts are lined up evenly along the wooden baseboard. The by-pass condenser C2 is screwed down just in back of the two fixed R.F. transformers, L1 and L2. The tube sockets are arranged in the same order as the tubes indicated in the schematic diagram on page 40; that is, R.F. on the left, detector and A.F. on the right.

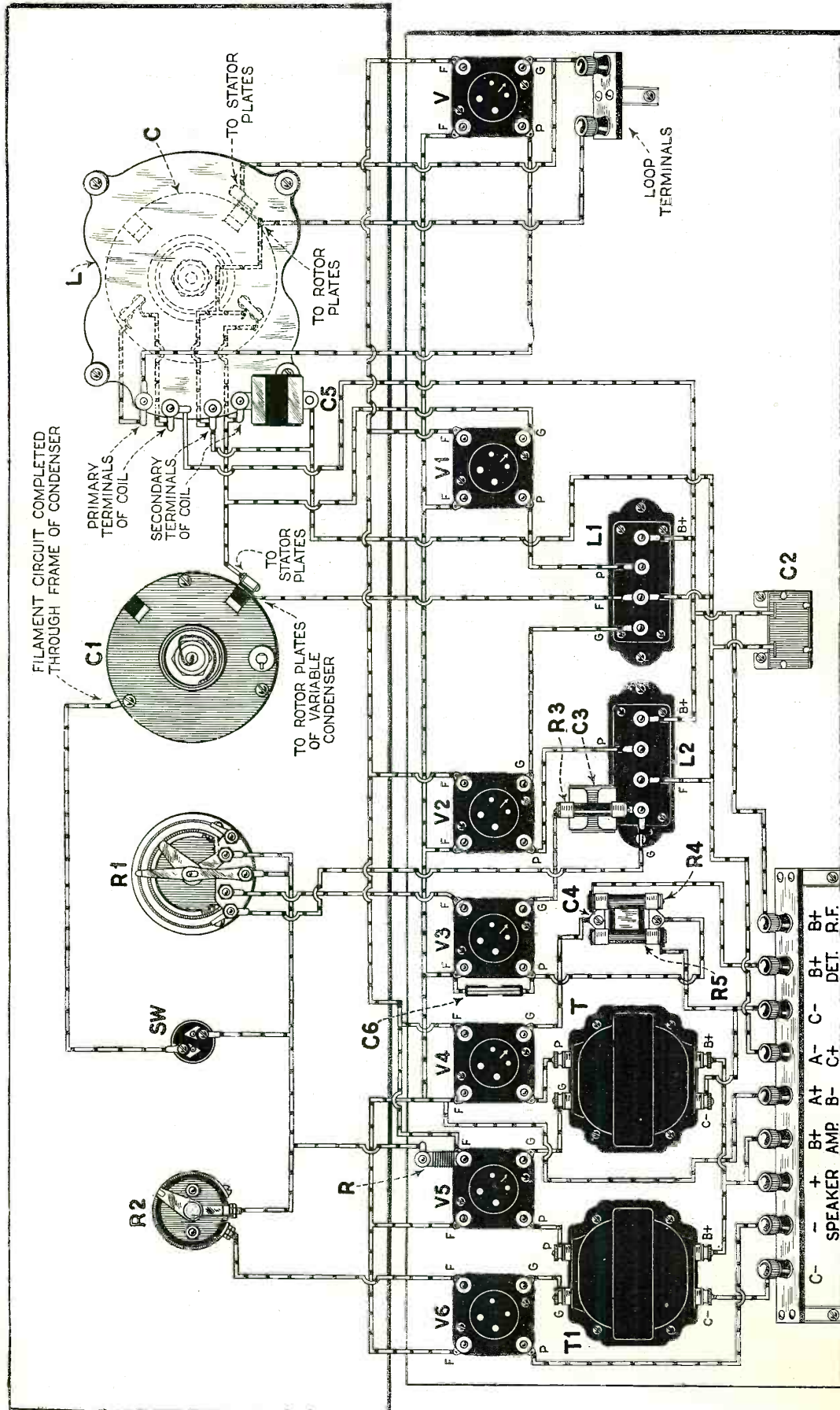

This pictorial wiring diagram shows every connection in the Acme "D" Coil Receiver, with the exception of the two wires which lead from the loop aerial to the two binding posts at the extreme right marked "Loop Terminals." The various parts have been drawn slightly smaller than they would appear in a scaled drawing, so that the constructor will be able to follow the wires more easily. As you solder each wire in place, draw a heavy pencil mark along the corresponding line on the drawing above. When all the lines have been completed the wiring of the receiver.

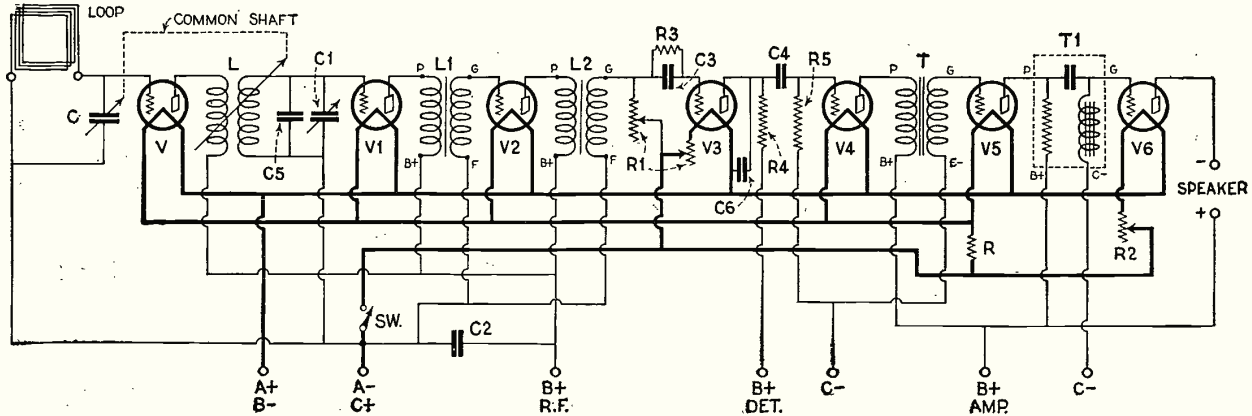

Complete schematic wiring diagram of the "D" Coil Receiver. This corresponds to the picture diagram on page 39; and may be used to advantage in conjunction with the latter, when the set is being wired. The fixed condenser indicated as C5 is supported from the back of the variable inductor L by means of its own connecting wires; it is shown in the picture diagram and in the back view of the receiver on page 38.

baseboard is given; because it is easier to "spot" the locations of the parts on the wood board and to screw the instruments down a few minutes later. No drilling is necessary, as the short wood screws can be turned in with a little pressure on the screwdriver. The half-tone illustrations and the picture wiring diagram show everything plainly. If the constructor will simply duplicate this layout he will experience no trouble of any kind.

tipped over a little to make easier the soldering of connecting wires to them. This construction will be greatly appreciated by any radio fan who has attempted to push a soldering iron between a baseboard and the

This is done to allow the set to slide into a cabinet.

Two wiring diagrams, one in picture and the other in schematic form, are given to aid the constructor in connecting up the re-

RADIO ON THE UPSWING

JULY usually is the low point of the year in the radio industry. This year, however, is an exception. The feeling in the trade is more optimistic than it has been for years during the same period. An opinion that is backed by actual cash may usually be taken as a true opinion. This year, for instance, RADIO NEWS shows a rather heavy increase in advertising over the preceding year. These are the figures:

July, 1926, advertising lineage	11,582
July, 1927, advertising lineage	13,134

This is an excellent barometer to show the actual condition in the trade, which may be said to be, right now, not only healthy, but better than for several years.

EASE OF CONNECTING

Two binding-post strips are used in the set; the smaller one, holding two posts for the loop terminals, is mounted at the left end of the baseboard, directly behind the socket for tube V. The other, 10½ inches long, holds nine posts for the various "A," "B" and "C" batteries and for the loud-speaker terminals. Both are raised several inches above the level of the baseboard by means of bent brackets.

The binding-post strips themselves are

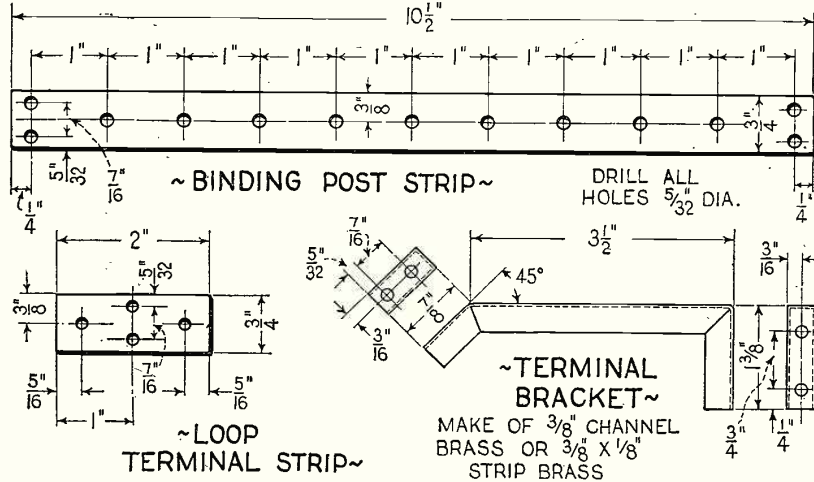
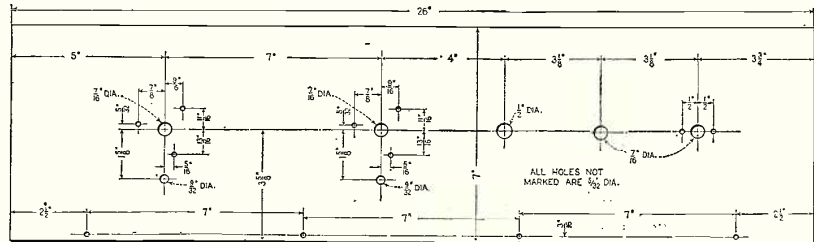

Top—Drilling layout for the front panel. Mark out all the holes with a hard, sharp pencil, and then make dents in the panel with a center punch wherever a hole is to be made. Do not attempt to drill without first doing this. Center—Layout of the long binding-post strip. Bottom—Details of the loop terminal strip and the supporting brackets; three of the latter are required.

bottom of a strip only half an inch or so above it.

Observe that the baseboard is centered on the bottom edge of the panel, so that the ends of the latter overlap it a half inch.

ceiver. If you follow the former, draw a heavy pencil line through each line on the drawing as you solder in place the wire represented by that line. Then, when you find that the whole diagram is blacked out, you can be certain that you have wired the set correctly.

In doing the wiring, solder the joints to soldering lugs wherever the latter are found on the various instruments. In many places entirely satisfactory connections can be made by means of screw binding posts.

TUBE RECOMMENDATIONS

For the R.F. amplifier positions, either regular 201A-type tubes or special R.F. tubes
(Continued on page 64)

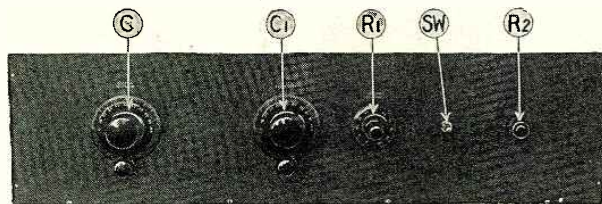

How the front of the panel appears. The loop aerial is not shown, being kept either next to the receiver on the table, or on top of its cabinet.

A Simple Roll-Type Loud Speaker

Easy and Inexpensive to Construct and Capable of Great Volume

By E. M. YARBROUGH

THE construction of this double-semi-cylinder loud speaker is simplicity itself, as a moment's consideration will show; and the cost of its materials is practically nothing, outside of the unit. It should make an immediate hit with a good many of our readers.—
EDITOR.

OF all loud speakers the writer has ever heard, the double-cylindrical diaphragm now to be described, built on the principle of Dr. de Forest's Audalon, is the most nearly perfect in reproduction. It is also, in contrast with most other paper-diaphragm devices, highly efficient, and absurdly cheap and simple to construct.

Briefly, this reproducer consists of a sheet of heavy paper folded in the middle, with the two halves rolled into semi-cylindrical shape so that the end view is like an "m"; the outer edges being supported, while the center of the crease floats on the diaphragm of a loud-speaker unit. This construction results in a quality of tone realized only by

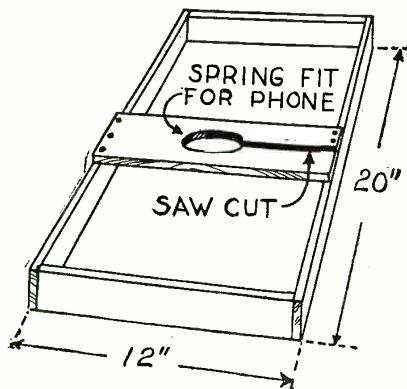

Fig. 2-A. The simple framework upon which the loud speaker is assembled.

the best free-edge cones, with a slight increase in actual volume over horn-type reproduction.

The only materials essential to its construction are a high-grade telephone unit, a cork, and a sheet of heavy art paper, about 20 x 30 inches, such as used for the covers of advertising pamphlets and programs. The latter may be obtained in several shades at any stationery store, or at the local print-shop, for about fifteen cents.

CONSTRUCTION IS EASY

Art paper comes with a colored parchment finish on one side. Fold the sheet in the middle by placing one end true with the other and creasing the fold, being sure that the parchment finish is on the *inside*. Fasten the edges together with wire paper-clips about two inches up from each end of the crease, in order to stiffen the crease. Mark the center of the crease and insert it into a knife slit in one end of a long, narrow cork. (See Fig. 1). This cork should be long enough to rest on the diaphragm of the phone without allowing the paper to touch the cap. Cork, being of nearly the same density as paper, makes a much better acoustic link than metal.

Make a light, rectangular, wooden frame, about a foot wide and the length of the crease. (See Fig. 2-A). In the center of the frame, fasten crosspiece to which the phone is to be attached. Mount the phone exactly in the center, using the method of fastening best adapted to the unit. Now tack the free ends of the paper to the side-pieces and set the cork link on the center of the diaphragm. (See Fig. 2-B). The instrument may now be used in a horizontal position with good results.

If it is desired to use the speaker in a vertical position, by standing it on end or hanging it on the wall, the crease must be supported from the end-pieces by light rubber bands, both to give the cork a proper contact with the diaphragm and to prevent sagging of the crease. The diagram makes this clear. If a drop of glue is used to stick the cork to the diaphragm, the tension on the bands need not be great.

FINISHING THE SPEAKER

The ornamentation of the finished product may be as simple or as elaborate as the constructor desires. However, if the result is to be in good taste, it is best to follow the old rule that construction should be ornamental in itself, and ornamentation constructional. Perhaps the best treatment would be to leave the two columns of paper unadorned, thus accenting the beauty of the parchment, and to provide at each end artistic guard rails, as illustrated, matching the style of furniture in the room in which the instrument is to be used. These rails should not touch the membrane. If the paper is used alone, a neat row of inked swastikas may be used at each end.

In order to get the best possible tone from the speaker (assuming of course that the output of the radio amplifier is distortionless) we must eliminate, as far as possible, the distortion arising from the use of a stretched metal diaphragm in the phone unit. The best low-priced units are those in which

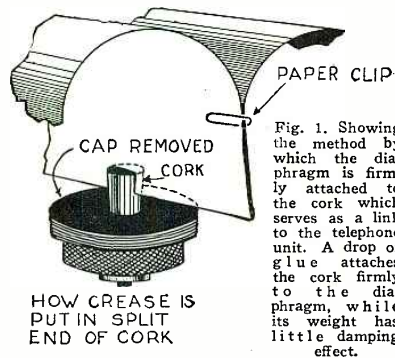
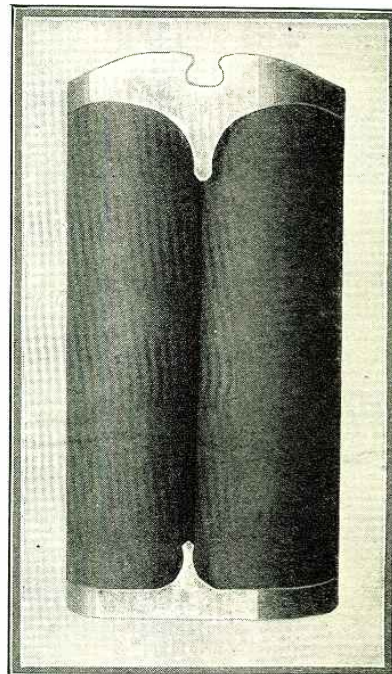

Fig. 1. Showing the method by which the diaphragm is firmly attached to the cork which serves as a link to the telephone unit. A drop of glue attaches the cork firmly to the diaphragm, while its weight has little damping effect.

a large diaphragm is supported between resilient washers, and in which the distance between the magnets and the diaphragm is adjustable. Simply unscrew the cap altogether and adjust the magnets until good tone and volume is had. The cork can now be made very short, resulting in better linkage, and may, if desired, be set on various parts of the diaphragm until the best point is found.

POWERFUL AND COMPACT

The efficiency of conversion by this speaker, of electrical energy into sound energy, is attested by the fact that the resultant sound is as loud and distinct all



One form of decoration by the use of an ornamental guard rail at each end of the diaphragm, if so desired. A very neat effect is thus obtained.

over the room as it is an inch from the membrane. As a result, excessively powerful signals are not necessary for good volume. The writer uses only 66 volts on three "bootleg" 199's in a Roberts Reflex, with a choke coil for the last step. But to hear this outfit talk, you would think that five hundred miles were five, and that "twenty bits" were "twenty bones."

The rectangular construction of this loudspeaker is admirably adapted for portable receivers, for the paper may be made removable from the sides, and folded flat, so that the whole may be packed in the lid of a suitcase. Another stunt is to use a single horizontal cylinder as a combination speaker and dust cover for an open-built

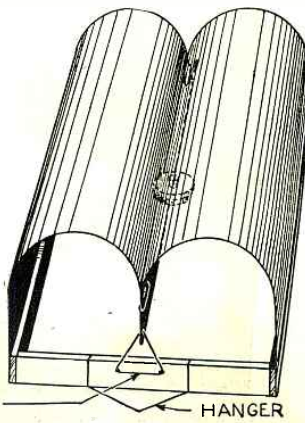

Fig. 2-B. The completed loud speaker, arranged for use on the wall, as viewed from the top. The position of the unit is indicated.

(Continued on page 91)

The "Ham's Own" Short-Wave Receiver

A Constructional Article on a Good DX Set for Amateurs
By JOHN L. REINARTZ

IN this, the second of his series of articles on short-wave apparatus, Mr. Reinartz describes the construction of a receiver of his own design, which can be used for receiving stations operating on wavelengths from 15 to 500 meters. The construction is novel in that all the apparatus is mounted on the front panel, no baseboard being used.

With an antenna stretched across a room this receiver has brought in amateur stations all over the country. For those "hams" who are on the look-out for a set which will give satisfaction in all ways, we heartily recommend this one. Further articles from Mr. Reinartz will appear in forthcoming issues of RADIO NEWS, the next being on the subject of wavemeters.

—EDITOR.

IN the June issue of RADIO NEWS the writer described the transmitter which he has found most efficient in short-wave work. This article describes a receiver which can be easily built by the average "ham" and which will be found to bring stations in not only the amateur band, but the broadcast band as well.

In designing this receiving set simplicity was the goal. As may be seen from the illustrations, no baseboard is used; all the apparatus being mounted on the panel, which is held in an upright position by two L-shaped brackets attached to the variable condensers. In this way connections between the different pieces of apparatus were shortened, and the whole construction made much simpler than is otherwise possible.

The circuit diagram which is shown at the right is that used in the short-wave receiver designed by Mr. Reinartz. As explained in the accompanying text, the coil D is not used when waves of 40 meters and below are being received. When this coil is out of the circuit the variable condenser, C3, is in series with the antenna and the coils A, B and C. The audio-frequency transformer, AFT, should have a ratio of 6:1, in order to get maximum amplification from the single stage. The tubes may be of either the 199 or the usual 6-volt type.

As may be seen from the schematic diagram, the receiver employs only two tubes, 201A and 112 types (or even two 199's); one a detector and the other an audio-frequency

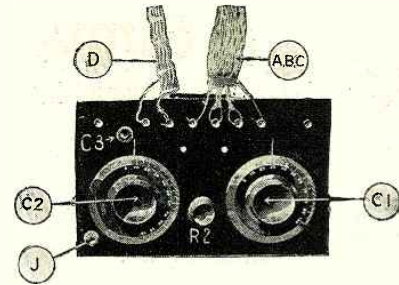

Panel view of the short-wave receiver.

amplifier. The circuit is designed for head-phone reception, so there is only one stage of audio-frequency amplification, which is quite sufficient for all work.

NOVEL CIRCUIT

First let us consider the circuit which is

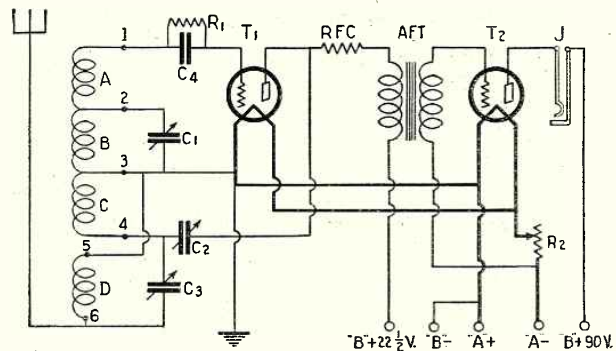
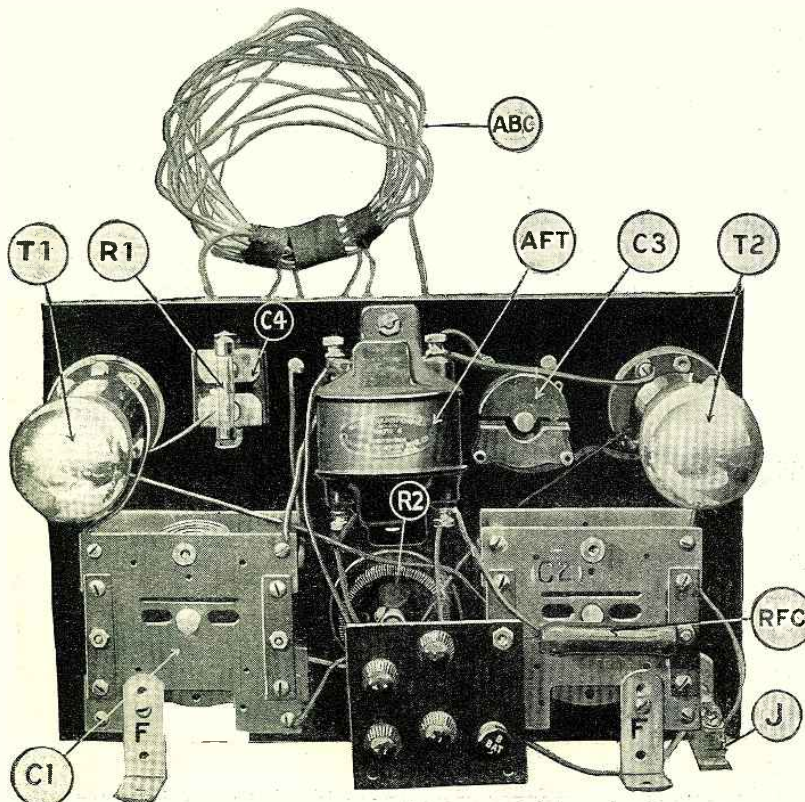

FIG. 1

used in this short-wave receiver (Fig. 1). It will be noticed that there are four inductances, A, B, C and D. As may be seen from the illustrations, these coils are bunch-wound, being wrapped together at the bottom with tape and the opposite sides being spread apart toroid fashion. Across the coil B is shunted a variable condenser C1, which has a capacity of 250 mmf. (.0025-mf.).

This method is used instead of shunting a small-capacity condenser across both coils, A and B, for several reasons. In the first place, if we have just a few turns in a coil shunted by a large capacity, even though there is a smaller voltage impressed on the grid of the detector tube, there is a comparatively small resistance (that of the condenser) in parallel with the coil. Now, if we have a coil composed of more turns and shunted with a smaller capacity, even though we have a greater voltage impressed on the grid, yet there is a much greater condenser resistance shunted across these same number of turns. In order to obtain a compromise between these two conditions, we shunt only part of the coil with a relatively large condenser, which has less resistance. We get the advantage of a greater voltage impressed on the grid of the detector tube, and the stations spread out over the whole range of the dial, instead of being grouped and crowded in spots. In short, it is well to use as large a condenser for tuning as is convenient and shunt that number of turns which will tune in the desired range of frequencies.

Just as in the transmitting end of the game, a short aerial should be used for the reception of waves under one hundred meters. This would necessitate using two aerials if broadcast stations were received also, but in the receiver here described this is automatically taken care of in this manner. It will be noticed that in the aerial side of the coil D is a small variable condenser C3 which has a value of 55 mmf.



As may be seen from the above illustration, all the apparatus of the receiver is mounted on the front panel. The feet, F, are attached to the rear of the variable condensers.

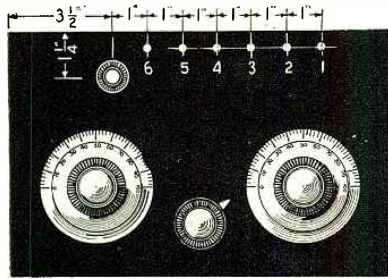

FIG. 2

The location of the binding posts, to which the coils are attached, are here shown.

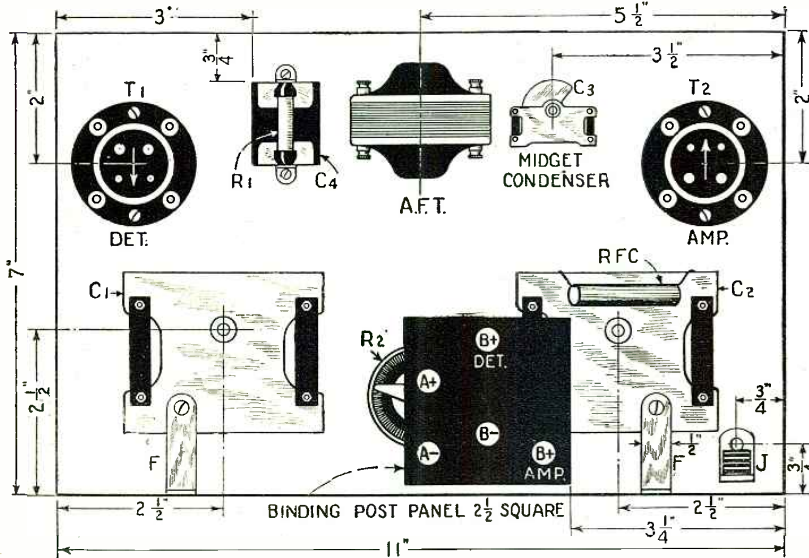

FIG. 3

The layout of the apparatus on the panel is given above, with the necessary dimensions.

Now, in the coil specifications for use on the 20- and 40-meter bands, this coil D is not specified because it is not used. Therefore, only the coils, A, B and C being in the circuit, the condenser C3 is in series with the antenna and the C coil. This has the desired effect of shortening the length of the antenna; so that the one used for broadcast reception can be used on this set with equally good results.

COIL SPECIFICATIONS

Following are the specifications for the different sets of bunch-wound coils to cover a wavelength range from 20 to 500 meters.

Wavelength	Coils—A	B	C	D
20 meters	4	2	2	—
40 meters	8	4	4	—
80 meters	16	8	8	4
150-200 meters	16	16	8	8
200-500 meters	32	16	8	8

These coils may be either wound on a form 3 inches in diameter or bunch-wound as suggested above. No. 16 D.C.C. wire is used throughout. If the coils are wound on a 3-inch form, the turns must be spaced for the wavelength ranges under 80 meters, the spacing being equal to the diameter of the wire. For the higher wavelength ranges the turns may be placed next to each other.

In the case of bunch-wound coils, which the writer uses in his receiver, the coils are all of the same diameter, 3 inches. They are fastened together at the bottom with tape and the leads to the binding posts on the front of the panel are spread out. The top sides of the turns are then spread apart, giving them a semi-toroid appearance.

It is very important that these coils be carefully prepared, so that there is a minimum of losses in their make-up. If it is desired to use any means, other than binding posts, of connecting these coils to the circuit it may be done; yet the system illustrated is the easiest to build and insures practically no contact resistance, which is sometimes considerable with other types of mountings.

REGENERATION CONTROL

It is highly desirable that the oscillation of the detector tube should at all times be completely under the control of the operator. To insure the set going into oscillation smoothly and without the usual "plop," a large grid leak is employed, 7 megohms. This value is not fixed, however, and

should be checked by the constructor. The condenser C2, which controls the oscillations, should be of a high grade, having the smallest possible minimum capacity. If a condenser of inferior workmanship is used in this position, the additional capacity, when the plates are all out, might necessitate that some turns be removed from C.

As another aid to the control of regeneration, there is inserted in the plate circuit of the detector tube a special radio-frequency choke coil, RFC. This choke can be obtained at any supply store and has a resistance of 1,000 ohms. Naturally the coil must be inductive.

This coil aids in regeneration control, because it brings the output circuit of the tube nearer in value to the internal impedance of the tube, which is about 8,000 ohms. The primary winding of the audio-frequency transformer is about 6,000 or 7,000 ohms. This is a rule that might be well followed by designers; i.e., to have the output of a circuit as nearly as possible equal in resistance or impedance to the generating part.

As mentioned previously, all the apparatus is mounted on the front panel, which is relatively small—7 by 11 inches. In the two upper corners of the panel are mounted the two UX-type vacuum-tube sockets; one with the filament holes at the lower side and the other with these holes toward the top of the panel. This is for ease in wiring.

In the center of the panel near the top is placed the 6:1 audio-frequency transformer, A.F.T. To the right of this, looking at the panel from the back, is the 55-mm. condenser C3 and the socket for the semi-power vacuum tube, these being on the secondary side of the transformer. Above the variable condenser C2 is mounted the radio-frequency choke coil RFC; and in the lower right corner of the panel is the single-circuit jack J. In this way all the output apparatus, if we may call it such, is grouped together, making short connections possible.

As no baseboard is used, some means must be provided to keep the panel in an (Continued on page 85.)

SYMBOL	Quantity	NAME OF PART	REMARKS	MANUFACTURER ★
C1, C2	2	Variable Condensers	.00025 mf.	1 9, 13, 14, 15, 17, 18, 19, 20, 21, 22
C3	1	Variable Condenser	55 mmf. (midget)	2 17, 18, 19, 20
AFT	1	A. F. Transformer	Ratio 6:1	3 9, 12, 18, 26, 27, 28, 29
C4	1	Fixed Condenser	.0005 mf. with grid leak mounting	4 10, 14, 30, 31, 33
R1	1	Grid leak	7 megohms	5 4, 10, 14, 24, 25, 30, 31, 32, 34, 35
R2	1	Rheostat	6 ohms	6 3, 9, 14, 15, 18, 20, 24, 26, 31, 34
	2	Sockets	UX type	7 9, 14, 18, 19, 20, 22, 23, 34, 36, 37
	11	Binding Posts		8 3, 14, 16, 34, 37, 38
	1	Panel	7 X 11 X 3/16 inches	54 39, 40, 41, 42, 43
	1	Binding Post Panel	2 1/2 X 2 - X 3/16 inches	54 39, 40, 41, 42, 43
		Wire for Coils	No. 16 D.C.C.	44 45, 46, 47, 48, 49
T1	1	Vacuum Tube	Type 20L-A	11 50, 51, 52, 53
T2	1	Vacuum Tube	Type 112	11 50, 51, 52, 58
	1	Jack	Single Circuit	38 9, 3
RF	1	R.F. Resistor	1000 ohms choke	55

NUMBERS IN LAST COLUMN REFER TO CODE NUMBERS BELOW.

1 National Co.	2 Precise Mfg. Co.	3 Hart & Hegeman Mfg. Co.
4 Dubilier Condenser Corp.	5 Deven Radio Corp.	6 F.A.D. Andrea, Inc. (Fada)
7 Alden Mfg. Co.	8 H. H. Eby Company	9 Pacent Electric Co.
10 Aerovox Wireless Corporation	11 Radio Corp. of America	12 Semon Elec. Co.
13 Heath Radio & Electric Mfg. Co.	14 Pilot Electric Co.	15 United Scientific Lab. (U S L)
16 A.L. Radio Lab.	17 Hammarlund Mfg. Co.	18 General Radio Co.
19 Silver-Marshall, Inc.	20 Chelton Electric Co.	21 Thompson-Levering Co.
22 Benjamin Electric Co.	23 Air-Sea Products Co.	24 Allen-Bradley Co.
25 International Resistance Co. (Durham)	26 General Instrument Corp.	27 Amer. Transformer Co. (Amertren)
28 Thordarson Electric Mfg. Co.	29 Jefferson Electric Mfg. Co.	30 Leslie F. Water Co.
31 De Jur Products Co.	32 Arthur H. Lynch, Inc.	33 Sprague Specialties Co.
34 Amco Products, Inc.	35 C. E. Munkford	36 Bremer-Tully Mfg. Co.
37 C. R. Lewis, Inc.	38 Yaxley Mfg. Co.	39 Crearadio Corp.
40 Formica Insulation Co.	41 American Hard Rubber Co. (Radion)	42 Fibroc Insulating Co.
43 Spaulding Fibre Co.	44 Cornish Wire Co.	45 Balden Mfg. Co.
46 Rose Wire Co.	47 Ross Wire Co.	48 L. S. Brach Mfg. Co.
49 Alpha Radio Supply Co.	50 Magnavox Co.	51 Ken-Rad Corp.
52 Zetka Laboratories, Inc.	53 C. E. Mfg. Co. (Ceco)	54 Bakelite, Corp.
55 Ward Leonard Elec. Co.		

★ THE FIGURES IN THE FIRST COLUMN OF MANUFACTURERS INDICATE THE MAKERS OF THE PARTS USED IN THE ORIGINAL EQUIPMENT DESCRIBED HERE.

If you use alternate parts instead of those listed in the first column of manufacturers, be careful to allow for any possible difference in size from those originally used in laying out and drilling the panel and sub-base.



A Compact Traveler's Set*

A Portable Which May be Tucked Away in One Corner of Your Bag

By HERMAN F. SWARTZ



"THE Man on the Road" will be delighted with this set, lighter and compacter many times over than the ordinary portable. It may be easily tucked, with its batteries, into a corner of his suit case; and is ready for use in his hotel room in a minute. The set illustrated serves the writer to bring in, night after night, not only locals, but stations of moderate power several hundred miles away. It is easy to build and very inexpensive, as will be seen. To the camper, also, it will be a boon this summer.

—EDITOR.

THE writer travels much, and like many other men of the road, he has longingly dreamed of a comfortably portable radio receiver. Many "portable" outfits have been described from time to time, but they are usually of a size suitable only for automobile transportation, and much too massive to be tossed into one corner of a hand-bag.

For a "really, truly" portable, the conditions and specifications run about thus: it must operate on a light-socket antenna for locals; cover a radius of at least five hundred miles on a good average antenna; pick out the little locals from the big ones; weigh not over three pounds exclusive of battery (battery should weigh no more than the receiver) be of small bulk; be strongly built to stand the hazards of travel; and finally, cost not over ten dollars.

This is an exacting bill of particulars, but we have fully met each requirement, with some additional advantages.

After much cogitation the choice of circuits was reduced to either a three-circuit regenerative or a reflex. Since distance was not so much desired as satisfactory reproduction with a comfortable volume of sound, the choice finally rested on the reflex. The hook-up is therefore a Harkness with slight modifications. Probably no other cir-

cuit will do more juggling with the incoming waves with so little apparatus.

ONE TUBE AND CRYSTAL

The circuit has often been published, but it is shown again for convenience in Fig. 1.

The theory of this circuit provides for the operation of the tube at a point just below oscillation, this being accomplished by feed-back through the plate-to-grid capacity of the tube. When a 201 A-type tube is used, as often is the case, there is so much capacity coupling through it that losses must be introduced in the circuit to prevent squealing. The 199-type tubes, however, have so much less inter-element capacity that the problem is to get enough feedback. Furthermore, since our coils have been designed for the maximum of efficiency compatible with small dimensions, we have reduced the capacity interaction between primaries and secondaries by the use of slot-winding. It is therefore important to give the R.F.-circuit as little unnecessary resistance as possible. While the ordinary Harkness circuit does not use a condenser across the phones, we have found a .001-mf. fixed condenser a great help, especially as the tube approaches oscillation.

The writer finds no other control of oscillation is needed, besides changing the pressure of the catwhisker. The builder can easily tell whether the set is properly regenerating by lifting the catwhisker. It should then squeal, or at least click, as resonance is reached at any point of the scale. At the longer wave-settings there may be no squeal unless the set is tuned to some station actually broadcasting on such longer waves. Then the carrier wave will be heard to squeal. If, then, the catwhisker is adjusted lightly in place, good clear reception will be enjoyed.

A BARGAIN CABINET

The container threatened to be a real problem, when the happy idea occurred to try one of the common card-catalog boxes. They are made of the best of oak, the workmanship is of the finest, they are both light and strong; and, not least important, all stationers carry them in stock. Trial revealed that a box for one hundred 4x6 cards would exactly meet the requirements, and at the surprisingly low cost of only

seventy-five cents. The inside measurements of the box used by the writer are 6 3/16"x3 3/4"x4 7/8".

Furthermore, no insulating panel is necessary, as the variable condensers, having grounded rotors, can be mounted on the bare wood without loss. The connections for the antenna and batteries, which should be well insulated, are carried on a small strip of insulating material described later.

There is one important caution to be observed when buying the box; if possible get one with a shallow lid and a deep, solid front to carry the condensers. Some of the best makes have a lid about 1 1/2 inches deep in front. Side-strap hinges are also better for our purpose than the ordinary type of back hinge, as the latter

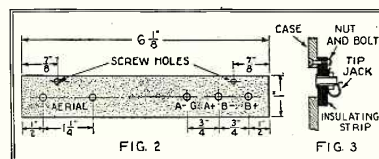

Fig. 2 shows the bakelite strip in which the tip jacks, shown in detail in Fig. 3, are installed.

thrusts the front of the lid forward when opening. To hold the lid shut, get a small flat brass hook, which will engage a 1/2-inch round-headed screw. The writer has placed this fastening at the right end of the box, where it interferes with nothing else.

The next serious puzzle is the variable condensers. Two of .00035 mf. capacity, are needed (see list of parts), and must be very small and compact.

The audio transformer is another "weighty" matter. Although only one is used, it might easily weigh almost as much as the rest of the outfit. However, fortune is again good to us, as there is a diminutive transformer which just suits the purpose. One is surprised at its output, both as to volume and quality.

The detector is a crystal. The writer has tried a half dozen kinds, fixed, semi-fixed, and fully adjustable, and of various substances. The answer is, use the very best grade of galena with an adjustable catwhisker. The detector is placed in a

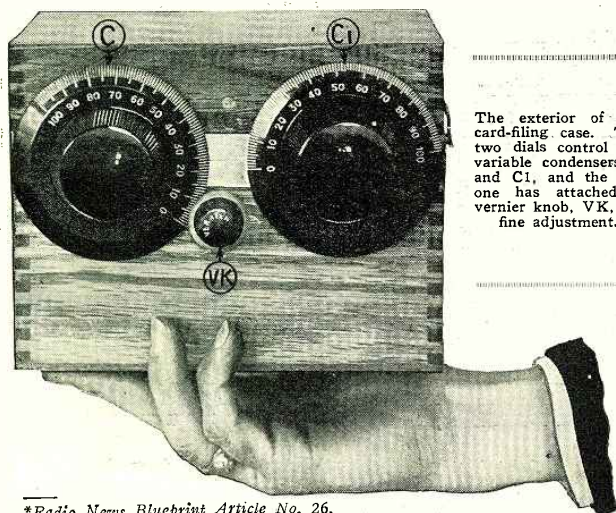

The exterior of the card-filing case. The two dials control the variable condensers, C and C1, and the left one has attached a vernier knob, VK, for fine adjustment.

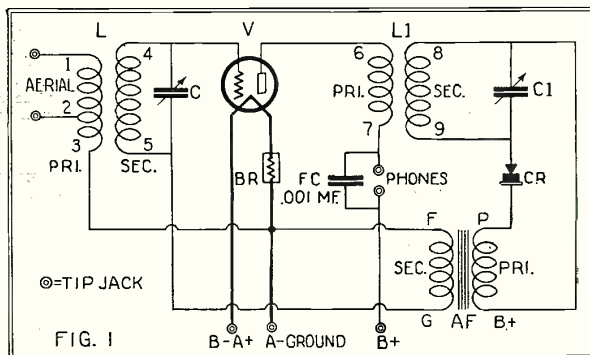

Above, in Fig. 1, is shown the schematic diagram of the one-tube reflex circuit used in this portable set.

most accessible position, and hence is easily adjustable. The writer has not been able to find any other detector device at once so sensitive, inexpensive, weighing so little and obtainable everywhere.

The tube is a 199. The socket must be of light weight and 1 1/2 inches in diameter. The filament control is a ballast resistor.

*Radio News Blueprint Article No. 26.

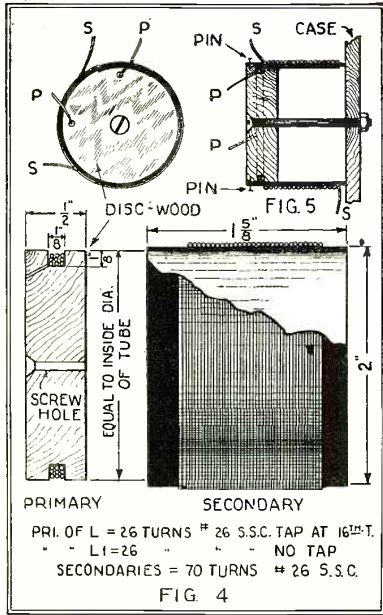

Above are given the directions for winding the R.F. coils.

CONNECTIONS

Instead of binding posts, tip jacks are used for aerial, ground, phone, and battery connections. They are lighter and more convenient for the making of connections so often required in the use of a portable. All these jacks, except the two for the telephone tips, are mounted on a strip of hard rubber or bakelite 6/8x1x3/16 inch. The jacks are arranged as shown in Fig. 2.

Drill five holes for jacks and two for 6/32 machine screws to attach the strip. It is placed on the *inside* of the box with the center line of the holes parallel to and 3 inches above the bottom, inside measure. Opposite each jack bore through the wood of the box a hole large enough to prevent the metal of the jacks from touching the wood anywhere. (See Fig. 3, also Fig. 6 for view of tip jacks on the back of carrying case.) Two phone jacks are mounted, one above the other, directly in the wood at the right end of the box. The upper jack is placed 1 inch from the back and level with the center of the bakelite strip carrying the battery connections. The other jack is 3/4 inch directly below.

MAKING THE COILS

Now we come to the coils. Secure two pieces of bakelite or hard rubber tubing 2 inches in outside diameter and 1 3/8 inches long. These are for the secondaries: 3/16 inch from one end mark a ring. With a very fine drill, say about No. 60, drill two holes in this ring, about 1/4 inch apart. These holes hold the wire at the beginning of the coil.

Drill two similar holes near the other end of the coil and 1 5/16 inches from the first pair. Wind exactly seventy turns of No. 26 S.S.C. wire, leaving about 4 inches of free wire at each end for connections.

We come now to the primary coils. They need a word of consideration.

A traveling set is subject to one uncertainty which a permanent installation escapes. This is the continually changing antenna, which must characterize its use, because of the "one night stand." Tonight the house wiring works admirably, but tomorrow night possibly the best collector will be the bed spring; while a third night may find the set on the tenth floor, which will

permit dropping an insulated wire out of the window. Such a variety of aerials necessitates an adjustable primary for the antenna coil.

A series of taps would doubtless be best, were we not doing all we can to insure compactness.

Considerable experiment has shown that sufficient accuracy of adjustment can be secured by winding this primary with twenty-six turns, taking out a tap at the sixteenth turn. This can be connected to the antenna most readily by using separate terminal jacks for the tap and for the full coil.

The writer, also, always carries with him a little fixed condenser of .0001-mf. capacity, which sometimes greatly improves selectivity if connected in series in the antenna line.

It may be suggested that there would be no structural difficulty in taking off two taps instead of one, these being at turns 16 and 22, and using 28 in all.

SLOT-WOUND PRIMARIES

The primaries are the only part of the construction which cannot easily be made without special tools, but the difficulty can be overcome for half a dollar at most. They require two discs of hardwood, 1/2-inch thick and of a diameter to fit snugly into the tubes of the secondaries. Any wood turner will make them for a few cents. These discs serve also to attach the coils to the box. On the tread of each disc have turned a slot 3/8-inch wide and 1/8-inch deep. This is to hold the primary coil. Drill from the bottom of the slot to the face of the disc through the 3/16-inch flange. This is

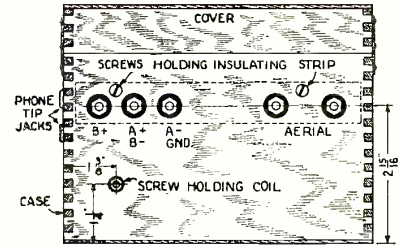
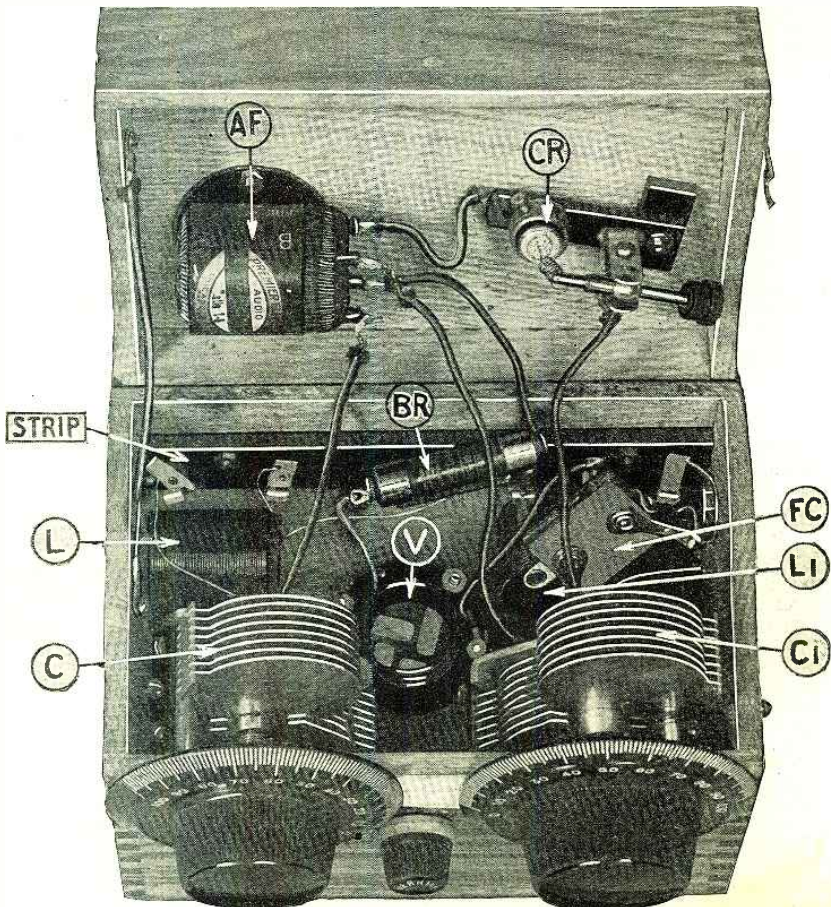

FIG. 6
 Rear of the cabinet, showing dimensions and location of jacks.

for the wire at the commencement of the coil. Make a notch in the same rim for the other end of the wire. Wind in each slot, jumble fashion, 26 turns of No. 26 S.S.C. wire; with a tap at the 16th turn of the antenna coil.

All coils are wound in the same direction. These coils will tune up to 550 meters with .00035-mf. condensers. (See Fig. 4.) Through the center of each disc bore a hole to pass a 6/32 machine screw to attach the coil to the box.

The primaries are then inserted inside the secondaries, so that the slot-wound coil comes under the very first turns of the secondary. With the No. 60 drill bore three equidistant holes through the free edge of the secondary tube into the wooden flange of the primary. Drive common brass pins, the kind the laundryman so generously supplies, into these holes, cutting off projections. (See Fig. 5.)



The interior of the receiver. C and C1 are clockwise and counter-clockwise condensers; L and L1, the R.F. coils; V, vacuum tube socket; FC, .001-mf. condenser; BR, filament-ballast resistor; AF, audio transformer, and CR, crystal detector.

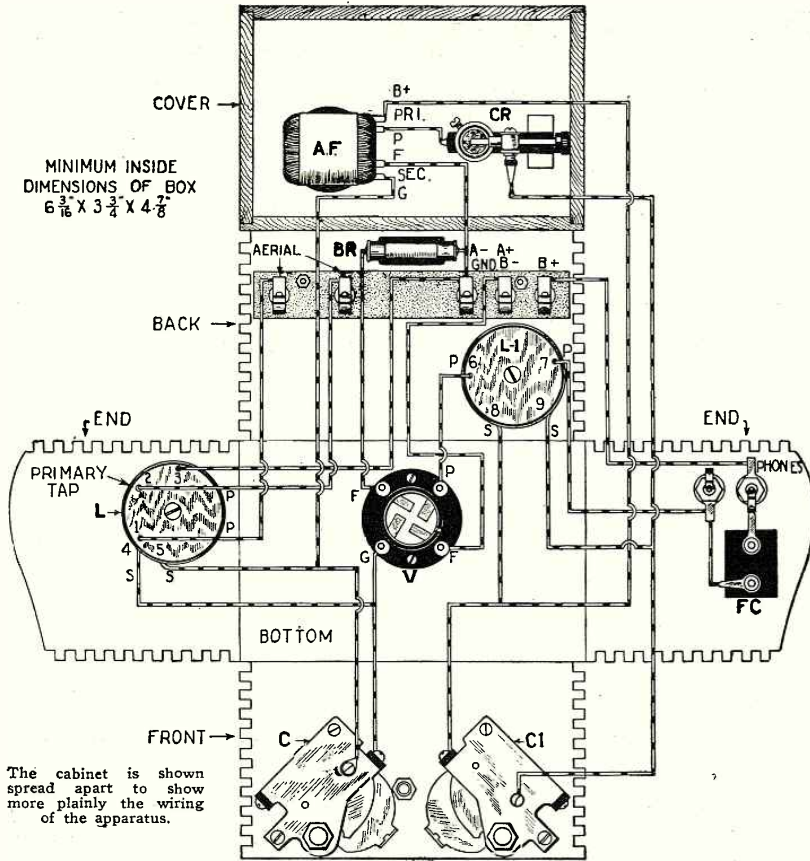

MINIMUM INSIDE DIMENSIONS OF BOX
6 3/16" X 3 3/4" X 4 7/8"

The cabinet is shown spread apart to show more plainly the wiring of the apparatus.

ASSEMBLY

First attach the binding post strip as already described. Next put in the socket. It does not sit in the middle of the bottom; but place its center 2 7/8 inches from the left-hand side and 1 1/8 inches from the back. Looking down on the socket, have the "G" post on the left front and the "P" post on the right rear. Connect the filament ballast mounting to the rear "F" post and solder the other end of the mounting to the "A—" tip jack. Run an insulated flexible lead from the other "F" post to the "A+" tip jack. This is all there is to the filament circuit.

Now mount the coils. The antenna coil, L, is fastened in the left rear corner. Bore and countersink a hole for a 6/32 machine bolt in the left end 1 1/8 inches above the bottom and 1 1/8 inches in front of the back wall, inside measurement. Mount the coil assembly by running a 2-inch machine screw through the box and the primary coil disc. The open end of the coil presses against the side of the box. Drawing up the nut securely anchors the coils and prevents the wires from touching the box at any point.

In like manner, the radio-frequency coil, L1, is mounted in the other rear corner with the plane of the winding parallel to the back of the box. Thus the magnetic fields of the coils are kept separated as far as possible and at right angles to each other.

The variable condensers should be the next consideration. If the builder uses the same apparatus employed by the writer, these will have to be placed with care, to avoid contact with the coils and with each other, yet permit the use of 3-inch dials.

The shaft centers are exactly 3 1/4 inches from the bottom and 1 1/8 inches from each end, inside measurement. Because the wood is 1/4-inch thick, single-hole mounting will not suffice. Two holes are provided in the

end plate for machine screws. Make a template and carefully locate these holes, countersinking for the screw heads.

The condenser sits at an angle such that the bottom edges, nearest the ends of the box, clear the wood by about 1/8-inch. This

will follow if one mounting screw is carefully located 11/16-inch below the center of the shaft hole and 5/16-inch toward the end. This is the only exact measurement required in the whole assembling.

WIRING HINTS

Now wire up the coils, condensers, socket, and tip jacks as shown. The projecting wires from the coils will serve for most of the connections thus far. Solder directly to the jacks, but use lugs wherever screw connections are made. Some of this work is a bit close, but none of it is really bothersome. A good bright iron is the key to comfort as well as to success.

The transformer is attached to the left inside of the lid in such a position as to permit the closing of the box without hitting either the left variable condenser or the tube. The long axis runs parallel with the back of the box. The crystal mounting goes in a similar position at the right end of the lid.

All connections between the apparatus in the lid and the equipment in the body of the box must be made in stranded insulated wire, for both flexibility and protection. The writer used the sort of wire generally employed for loops. Solder to the transformer terminals and tip jacks and use lugs for the other connections.

Take a 3-inch piece of the same kind of flexible wire, solder a lug securely on each end, and screw one lug on the inside of the lid, and the other on the inside of the box at the left end, in such a position as to permit the lid to open sufficiently and there stop—with the strain on this wire and not on the set wiring.

Attach the dials to the condensers. These are numbered in opposite directions to match the swing of the rotors. A piece of ruled paper serves as an indicator. See the front view of the set. A vernier button on the left dial is a convenience.

ACCESSORIES

What is the use of planning to save every ounce of weight and then sacrificing all the gain by toting around a lot of heavy batteries? The tube needs 4 1/2 volts of "A" (Continued on page 70)

SYMBOL	Quantity	NAME OF PART	REMARKS	MANUFACTURER*
C, C1	2	Variable Condensers	.00035 mf.	1 36
AF	1	A.F. Transformer	4:1 ratio	2
V	1	Socket	199 type	3 11, 13, 14, 15, 16, 17, 18, 22
	7	Tip Jacks		4 3, 47, 48
CR	1	Crystal Detector		5 28, 49, 50
BR	1	Ballast Resistor	199 type	6 43, 44, 45
FC	1	Fixed Condenser	.001 mf.	7 1, 18, 19, 20, 21, 22, 23, 24
	1	Vacuum Tube	199 type	8 25, 26, 27, 28, 29, 30, 31
L	1	Antenna Coupler	Specially wound	
L1	1	R.F. Transformer	Specially wound	
	1	Card filing case	6 3/16" X 3 3/4" X 4 7/8" (inside)	
VK	1	Vernier Knob		5 3, 24, 40
	2	Dials	3 inch diameter	10 14, 22, 32, 38, 39, 40, 41, 42
	1	Connector Strip	6 1/8" X 1" X 3/16"	32 11, 22, 33, 34, 35, 36, 37
	1	Telephone Receiver		47 9, 12, 40, 51, 52, 53, 54

NUMBERS IN LAST COLUMN REFER TO CODE NUMBERS BELOW.

1 United Scientific Laboratories, Inc.	2 Premier Elec. Co.	3 Alden Mfg. Co.
4 Carter Radio Co.	5 Radio Specialty Company	6 Radial Co.
7 Aerovox Wireless Corp.	8 Radio Corporation of America	9 Kellogg Switchboard & Supply Co.
10 Kurz-Knoch Company	11 American Hard Rubber Co. (Radion)	12 Conn. Tel. & Elec. Co.
13 Insulating Co. of America, Inc.	14 General Insulators Co.	15 Circle F Mfg. Co.
16 Benjamin Elec. Mfg. Co.	17 American Insulator Corp.	18 Electrical Research Labs. (Eria)
19 Argus Radio Corp.	20 Electrodyns Co. Inc.	21 Chae. Freshman Co. Inc.
22 Pilot Elec. Co. Inc.	23 Revolian Radio Corp.	24 De Jur Products Co.
25 Comover Electric Lab.	26 Gable Supply Co., Inc.	27 Gem Tube Co.
28 Tectron Radio Corp.	29 Emerson Radval Corp.	30 Sylvania Products Co.
31 Van Horne Co., Inc.	32 Insulating Company of America	33 Cresradio Corp.
34 Spaulding Fibre Co.	35 Vulcanized Rubber Co.	36 Starratt Mfg. Co.
37 Formica Insulation Co.	38 Valley Elec. Co.	39 Crowe Name Plate & Mfg. Co.
40 Hart & Hegeman Mfg. Co.	41 Karas Elec. Co.	42 S & S Radio Co.
43 Doven Radio Corp.	44 Langwin-Kaufman Radio Co.	45 L. S. Beach Mfg. Co.
46 Arma Radio Laboratories	47 H. Prost, Inc.	48 Varley Mfg. Co.
49 Steinitz Laboratories	50 L. H. Bunnell & Co.	51 Nathaniel Baldwin, Inc.
52 Ambassador Sales Co.	53 Trimm Radio Mfg. Co.	54 Federal Radio Corp.

* THE FIGURES IN THE FIRST COLUMN OF MANUFACTURERS INDICATE THE MAKERS OF THE PARTS USED IN THE ORIGINAL EQUIPMENT DESCRIBED HERE.

If you use alternate parts instead of those listed in the first column of manufacturers, be careful to allow for any possible difference in size from those originally used in laying out and drilling the panel and sub-base.

Building a Remote-Speaker Cabinet

Excellent Quality May Be Obtained Through the Use of This Horn and Cone Combination

By HERBERT C. MCKAY

IN this constructional article Mr. McKay has given full details for building a cabinet in which can be placed one or two loud speakers. Sometimes the disposition of these very necessary instruments is a real problem, from not only an acoustical point of view, but also from the aesthetic side. This cabinet has openings in the doors which can be easily lined with some thin fabric, and thus made to harmonize with any surroundings. A selector switch and a high resistor in the front panel give complete control of the speakers within.—EDITOR.

IN these days, when quality is the aim of all radio fans, nothing should be overlooked to attain this goal. It is well known that too close an association between set, speaker and batteries will

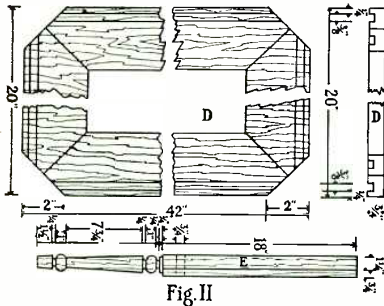

Fig. 2. Details for the legs and corners of the cabinet and the shelf members are given herewith.

result in pick-ups which interfere with quality. In view of this fact, these accessories should be removed from the immediate vicinity of the set. This may be done by placing the speaker upon a table at some distance and relegating the batteries to the basement, but such a method has its disadvantages.

In the first place, many fans object to the appearance of the exposed horn or cone, and with reason. Again, the basement is not the most convenient location for batteries. To overcome these objections, yet gain the advantage of a remote speaker and battery accommodation, this speaker cabinet was built.

Briefly, the cabinet consists of a low console, of a height which will make it convenient for use as a table. Inside this console there is space for two speakers—a horn and a cone. On the front panel is located a selective switch which will enable the operator to secure both speakers in series or in parallel, either speaker alone or both off. (See Figs. 7 and 8.) Below this switch, in the horn circuit, is a high resistance, in the order of 200,000 ohms, which will act as a balancer between the two speakers. There is also ample space for "A" battery, charger and "B" socket-power unit.

MATERIALS REQUIRED

As will be seen from Fig. 3, the overall dimensions are 31½ x 44 inches. The extreme depth is 21½ inches. The materials

needed are the following pieces of suitable wood:

- Four 2x2x30 in. (legs);
- Two 1x3x42 in. (shelf members);
- Two 1x3x20 in. (shelf members);
- Two 1x3x21½ in. (lid members);
- Two 1x3x44 in. (lid members);
- One 1x3½x16 in. (mid-panel);
- Two ¾x16¼x17¾ in. (front panels);

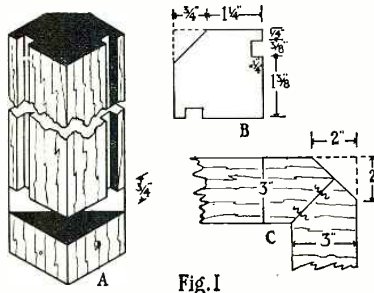

Fig. 1

Details are shown above for the construction of the legs of the cabinet, if a lathe is not available.

- Two ¾x16¼x16¼ in. (end panels);
- One ¾x16¼x38½ in. (rear panel);
- One ¾x19¼x41¼ in. (shelf);
- One ¾x17½x40 in. (lid panel);
- One 1x2x38 in. (rear stretcher);
- Two 1x2x16 in. (end stretchers).

In addition there are needed two hinges and two hinged braces for the lid, screws, brads, corrugated fasteners, plastic wood, stain, shellac and wax.

CONSTRUCTION

The legs may be made in any desired form; that shown at E (Fig. 2) was used by the writer. The corner was ripped from the leg pieces. Then a circle was drawn upon the end for use as a guide in turning, and the lower part of the leg turned as shown. In case a lathe is not available, the legs may be left square and tapered as shown in Fig. 3.

After turning or tapering, a notch ¾ inch wide is cut across the leg from corner to corner, diagonally as shown at A (Fig. 1).

This notch receives the corner of the shelf. The top of this notch is sixteen inches from the top of the leg, fixing the height of the shelf. When this is done, two dadoes ¾ inch wide are cut as shown at A (Fig. 1). These dadoes are ¼ inch deep, and receive the ¾-inch, three-ply panels. This completes the legs.

The shelf is made by mitering the shelf members and fastening with three corrugated fasteners at each corner, two on the lower side and one on the upper. When this is done, the corners are cut off as shown at C (Fig. 1) and D (Fig. 2). (B in Fig. 1 shows the leg section.)

Dadoes are cut in the top of the shelf ¼ inch from the edge, ¼ inch deep and ¾ inch wide, to correspond with the dadoes in the legs. This may be done either before or after assembling the shelf. Using a small power saw with a dado head, it is easy to do this after the assembly, making a closer job.

The shelf is now fitted to the legs by in-

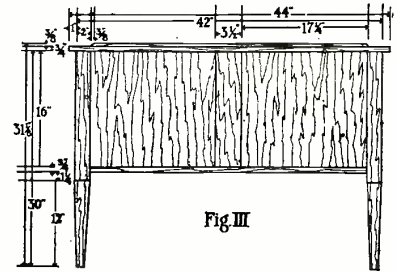
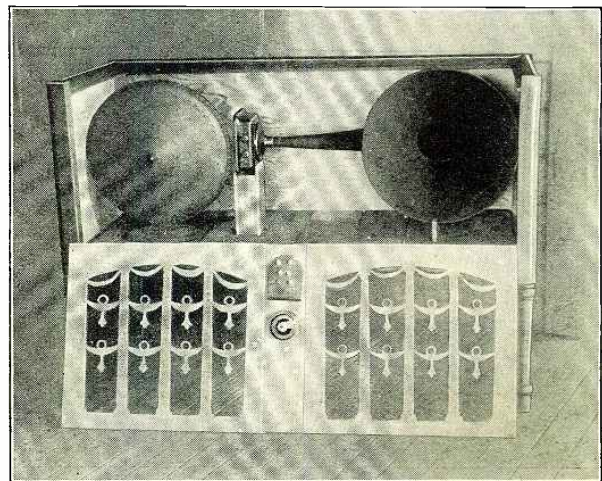
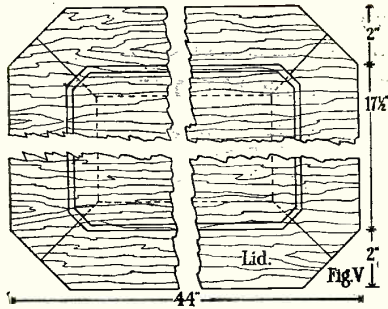

Fig. 3. Here are given the principal dimensions of the loud-speaker cabinet.

serting the corners of the shelf in the notches cut in the legs. Be sure that a good fit is made and that the edges of shelf and legs match exactly. This will entail some chiselling and hand-fitting. When a good fit is secured, remove the legs, paint a liberal quantity of good glue in the notch, replace the shelf and secure by driving two 1½-inch brads into the shelf from the two outside faces of each leg. Now toenail the inside faces of the legs to the shelf.

At the right is shown the finished remote loud-speaker cabinet. As mentioned in the accompanying text, it is found that two loud speakers, one of the horn and one of the cone type, give the best reproduction. The decorative front piece of the cabinet is lowered in order that the disposition of the two speakers may be clearly shown. The instructions for this mounting are given in the accompanying text. In the center of the front panel will be seen the selector switch and a resistor for controlling the volume of the output. The details for making this switch will be found on page 49.





Notch the shelf panel, and lay it in place. True up the assembly with a square and secure the panel with 3/4-inch screws placed about every four inches around all sides. This will brace the assembly.

Try end and rear panels for fit. If they fit snugly, remove them, paint the dadoses with glue, replace the end and rear panels, and secure with a 1-inch brad through each top corner, from the outside.

Place stretchers between the tops of the legs, inside, on ends and at rear. Secure these with a 1-inch brad every six inches, from the outside, 1/2 inch from the top of the panel. Secure to legs by 1 1/2-inch screws placed diagonally.

DECORATIVE DESIGN

The front panels are then cut out with a fret saw as shown in Fig. 4. The opening is outlined first according to dimensions shown. The bases and capitals of the pillars are drawn, each 1/4 inch deep. The pillars are 1 inch wide at the bottom and 3/4 inch wide at the top. When the pillars are drawn, draw the four lines C-D, E-F, G-H and J-K. Place these according to dimensions shown.

Set your dividers at a 2-inch radius. Then, from points "b" as centers; and from the intersection of lines E-F and J-K with edges of the pillars as centers draw intersecting arcs to determine points B. With these as centers, draw the arcs shown. Then, with a 3 1/2-inch radius, follow the same procedure; using points "a" and the intersection of lines C-D and G-H with edges of pillars as centers. This locates points A. Using these in turn as centers draw the flatter arcs. The arc which determines the top of the entire opening is drawn with a 24-inch radius.

This locates pillars and garlands. Now draw center lines in each of the four spaces. Where lines C-D and G-H intersect these center lines, draw two concentric circles whose radii are 1/4 and 3/8 inch, respectively. Finally draw the ornamental drops as shown in the right lower portion of Fig. 4.

At the right is Fig. 4, in which are provided the details for cutting out the front panels with a fret saw. Although these decorations may seem not altogether necessary, yet there must be an opening of some shape in the front panels, so that there will be no impediment to the egress of the sound from the loud speakers. If it is desired to have a plainer opening, one more simple can doubtless be devised by the ingenious constructor. At the left is Fig. 5, which gives the dimensions of the lid and its general shape.

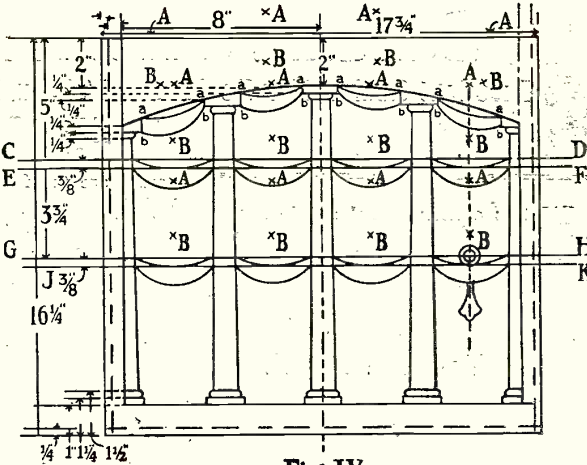

Fig. IV

Only one circle and drop is shown, to preserve the clarity of the drawing.

The first step is to cut the openings in

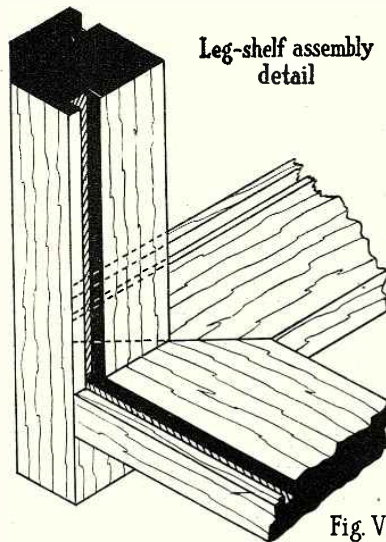

Fig. VI

Fig. 6.—Here is shown the method used in joining the legs to the shelf of the cabinet.

the small circles, using a 1/2-inch bit for the purpose. This is done first to prevent tearing the wood, as would result if the

outer circle were cut first. Then cut out the rest of the design in the usual way.

Cut dadoses in the edge of the mid-panel. Set it in place and mark the notch necessary to be cut in the front edge of the shelf panel to receive this mid-panel. Cut this out with a chisel.

Mount the switch and resistance upon the mid-panel, set it in place and secure with two 2-inch screws from beneath, passing through the front shelf member. Now glue the dadoses and insert the front panels as has been described.

The lid is made just as the shelf was. If the legs have the corners cut off, the corners of the lid will also be cut off as shown; but if the legs are left square-cornered, the lid will also be left square. The lid panel is cut 2 inches smaller on all sides (4 inches less on each dimension) and the edges bevelled at 45°. The lid panel is placed in position and secured with two 1-inch brads at each corner. The lid is then reversed and the panel secured with a 1-inch screw every four inches around all edges. The 1-inch screw will not quite pass through both pieces.

The lid is hinged to the legs with good steel butts and the brackets are put in place. These brackets allow the lid to be raised and hold it up a little past the center. They prevent strain upon the hinges. Such braces can be purchased for about twenty-five cents a pair at any hardware or radio supply store.

FINISHING

The entire cabinet is then carefully scraped and sanded and a coat of spirit- or oil-stain applied. If a two-tone effect is desired, draw the pattern, cut the pattern into the wood for about 1/16 inch with a sharp knife. This prevents the stain and filler from spreading. Now rub into the portions which are to be light, a good wood filler. When the stain is applied, the portions thus treated will not take nearly so much of the stain and will give a good two-tone effect. A very good color is obtained by mixing walnut and mahogany stains. The walnut alone tends to give a dead, blackish color in soft wood, without the brownish cast of true walnut.

When this stain is thoroughly dry, the cabinet is given a coat of shellac. When this is dry, the wax is applied and rubbed in thoroughly. Two coats of wax are advised at intervals of about twenty-four hours.

When this is done, thin silk of any appropriate shade is carefully glued to the front panels, on the rear side, of course. This silk is stretched tightly and left to dry. When it is dry the cabinet is complete.

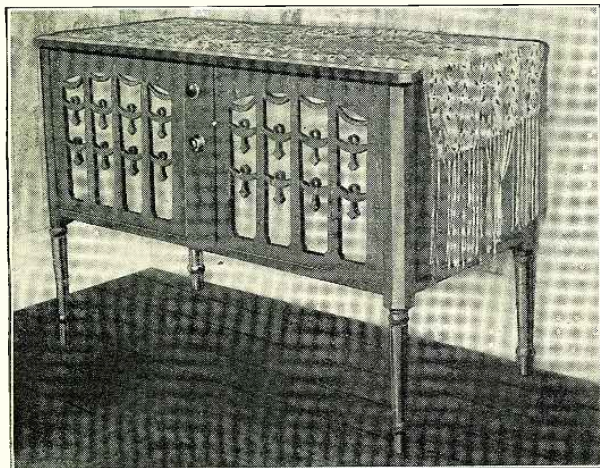

At the left is shown the completed loud speaker cabinet. As explained in the accompanying text, if the open-work front panels are lined with thin cloth a very harmonious combination may be made with the existing color scheme of the room in which the cabinet is to be installed. Another very advantageous use to which this cabinet can be put during the summer months, is to place it on the porch where it will furnish radio entertainment to the family and, at the same time, be a useful piece of furniture.

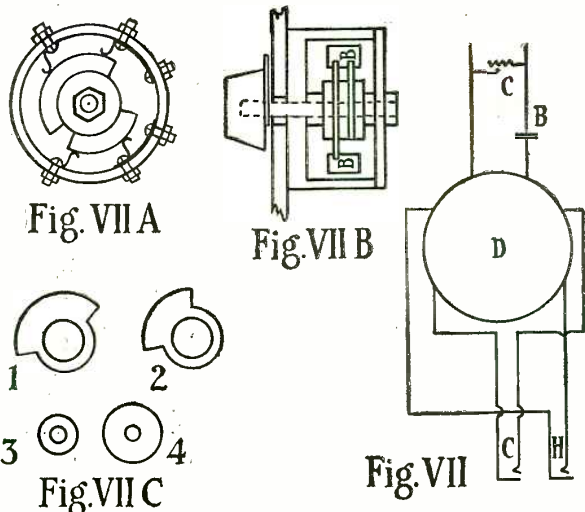

In Fig. 7, at the left, are shown the details of the selector switch and in Fig. 8, at the right, are the switch positions, as enumerated at the end of the article.

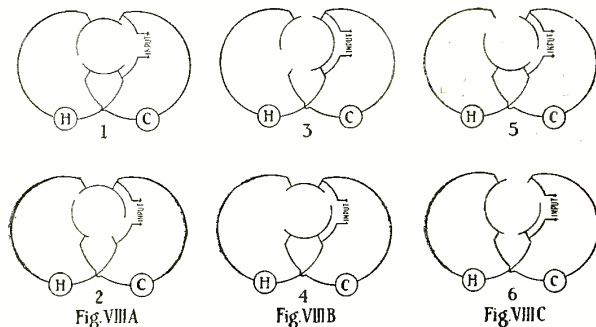

MOUNTING THE SPEAKERS
 In the case of larger horns, the horn will probably have to be laid upon its side. This requires three cradles for support; one at the base, one at the edge of the bell, and one midway along the gooseneck. The batteries, etc., may be placed in any convenient spaces.

In setting up, a series of 1/4-inch holes bored in the back panel will admit the necessary connecting cords.

In use, it may often be convenient to house the set in a table cabinet, provided with handles at the ends. The set is placed upon this speaker cabinet when not in use. When in use it may be placed upon any convenient table six feet or more from the speakers. This gives all of the quality of the remote speakers without crowding two consoles into a room which may be small.

CONTROL FOR SPEAKERS

The two knobs on the central panel of the cabinet provide full control of the speakers. The upper knob is connected to a six-point selector switch and the lower knob is connected to a high resistance, which may be a heavy resistor of the conventional type.

Reference to Fig. 7 will plainly show how the selector switch is made. The frame is an old receiver shell, and the other parts will be found in any experimenter's "junk" box. Fig. 7A is a plan view of the assembly and 7B is a section. It will be seen that four wiping contacts have been secured to the inside of the receiver shell by means of machine screws, size 6-32. The nuts provide connection on the outside of the shell. It will also be seen that one upper and one lower contact are connected to two extra binding posts. This is the input circuit.

If the switch be divided by a horizontal line we have on each side, one input, one horn and one cone connection.

The switch blades are made of 1/16-inch brass. They are sectors of 95° and 135°, respectively, bored large to take an insulating bushing. These are assembled upon a 3/16-inch shaft, pieces of 1/8-inch hard rubber being used for separators. Such rubber can be found in old storage-battery jars. The assembly of sectors and shaft is slipped into the shell. Holes drilled in the rear of the shell provide mounting. A strip of hard rubber, 1/8x1/2 inch, is secured across the open end of the shell; it has a hole drilled to take the free end of the shaft with a nut or collar to hold the shaft in place. The dial anchors the other end of the shaft.

This is the simplest form for this switch. The switch shown in the illustration is identical in action; but the sectors are riveted to a flat disc and the contacts are sidwiping, thus forming a two-disc switch. It is more difficult to secure good contact in the disc type of switch than in the

type just described. The receiver switch has been substituted for the disc switch in the speaker console described.

In case the set is not provided with an output unit, one such may be placed in the speaker cabinet, or a good A.F. choke and by-pass condenser may be mounted on the



At the right, the interior of the partially-assembled loud-speaker cabinet.

SHORT WAVES ROUND THE EARTH

THE curvature of the earth's surface, which is not shown upon maps, often leads to mistaken ideas about the shortest path of radio signals. Amateurs and DX listeners often make erroneous claims in perfect good faith. Apart from this, it is possible that the course of waves, especially short ones, may depart from the "great-circle" course which marks the shortest line on the earth's surface.

So amateurs have claimed 16,000-mile reception, on the assumption that signals could not cross a daylight zone between their stations; somewhat oblivious of the facts, that a true direct course may lead through the regions of polar darkness, and that the longer path (in the opposite directions) involves as much of daylight as the shorter one, in addition to the darkened semicircle.

But it appears from recent measurements

made at Geltow, in Germany, that 26,000-mile reception on short waves may be a fact. In other words, that sufficiently powerful signals may travel a distance *exceeding the circumference of the surface of the earth*. This is based on the observation that when signals are received on 15 meters from Nauen (only 25 miles away) the wave has something in the nature of an echo at an interval of one-seventh of a second, a period corresponding to a little more than a 26,000-mile journey of the magnetic waves. This is equal to a circular course round the world at a height of about 220 miles, and is probably caused by successive reflections from higher and lower strata. Between Geltow and New York a doubling of signals on 16.2 meters has also been noted, with an interval of one-tenth of a second; indicating a difference of about 18,000 miles,

in the distances traveled by different impulses; or that between the longer and shorter arcs of the great circle passing through the two stations. These effects were noted upon automatic recorders, and thus very accurately measured.

The increasing vogue of beam transmission should produce further valuable data.

HEIGHT AND SPEED OF WAVES

However, the estimate above given for the height of the globe-circling waves is challenged by a British radio engineer, G. W. O. Howe, who comments that it is based on the assumption that the waves are traveling in a vacuum with the velocity of light. "Since the waves travel in an ionized medium," he maintains, "they have a phase velocity higher and a group velocity lower

(Continued on page 76)



A New Electron Tube

Furnishing at Radio Frequencies an Amplification of 40 Per Stage

By SYLVAN HARRIS



EVER since the great development of radio began, that is, within the last fifteen or twenty years, there has been a crying need for an electron tube which would enable us to amplify small voltages at radio frequencies, without having to battle that ever-present difficulty known as regeneration. It is well known that regeneration in radio-frequency amplifiers is due to a feed-back of energy, from the plate circuits of these amplifiers to the grid circuits, through the inter-element capacities within the tubes.

The small capacities existing within the tubes, that is, between the grid and plate, between the grid and filament, and between the plate and filament, although very small in actual magnitude (being about 10 micro-microfarads or thereabouts in the 201A type of tube) have a considerable effect on the operation of radio-frequency amplifiers, especially at frequencies above, say, 750 kilocycles per second (400 meters). To be exact, the feed-back of energy depends upon the reactance of these small condensers in the tubes; and, as the frequency becomes higher and higher (that is, the wavelength becomes shorter and shorter), this reactance becomes less and less.

On account of this, the small capacities within the tubes can pass quite a large feed-back current at the higher frequencies, with the result that the regenerative effects are very pronounced at these frequencies, and sometimes difficult to control.

CONTROL OF REGENERATION

The regeneration in an electron-tube circuit depends upon five important factors, viz.: the capacities between the electrodes in the tube (principally between the grid and the plate); the inductance in the plate circuit of the tube; the internal plate-resistance of the tube; the frequency of the signal voltages to be amplified; and the resistance of the tuned circuits.

In order to keep the regeneration below the critical point at which self-oscillation occurs, it is necessary to introduce into

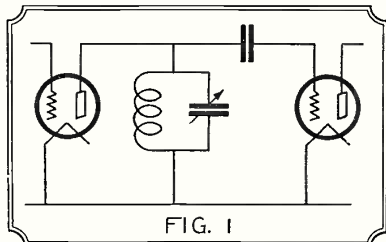

In a simple circuit like the above, regenerative effects are the drawback of high-amplification tubes.

the circuits means of controlling these factors:

(a) First, we might eliminate the effect of the grid-plate capacity of the tube by balancing it out in a bridge network, or by some other neutralizing scheme.

(b) Although we may not be able to eliminate successfully the inductance in the plate circuits of the tubes, we might eliminate its effect, which leads us to the so-called "zero-reactance plate circuit." Nothing concerning this form of circuit has as yet appeared in print, but the writer has in preparation an article on this subject which he hopes to publish soon.

(c) The "B" voltages impressed on the plates of the tubes may be kept small; when this is done the tubes are operated under such conditions that their plate resistances are high. This means a considerable reduction of the efficiency of the circuit.

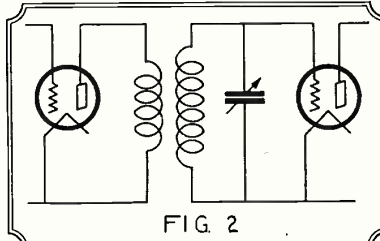

Another familiar circuit, in which unwanted regeneration is a governing factor.

(d) The tuned circuits may be made very inefficient, having in them plenty of resistance or other losses. This applies also to the interstage coupling transformers, which are generally very inefficient because of the very small mutual inductance between the two windings.

Now, it is clear that, by doing any or all of these things except perhaps the first, we are impairing the efficiency of the amplifier. As concerns neutralizing the tube capacities, we cannot discuss this very much here; it is well known, however, that these neutralizing schemes have limitations which militate against designing radio receivers to give amplifications per stage of more than perhaps 15, or in some cases perhaps 20. Many of the bridge circuits do not balance perfectly over the whole range of broadcast frequencies; and those for which it is claimed they do, have other limitations.

METHODS OF COUPLING

Suppose we consider a simple circuit like that shown in Fig. 1. We can design the tuned circuits between the tubes to have very little resistance; and so, when tuned to the frequency of the impressed signal voltage, they would give us a coupling impedance which would be extremely great. Under such conditions there would be little or no loss of amplification in the couplings between the tubes and, if it were not for the regenerative effects which we would encounter, we could build the tubes to give any amount of voltage amplification we desire, even perhaps a hundred or more.

But, as you know, when we try a circuit like this, we have to use a potentiometer or some other means to control the tendency to oscillate; for we have in the plate circuits a large inductive reactance and we also have the capacities within the tubes.

Or, let us consider the circuit in Fig. 2, with which most of us are acquainted. If we could simply go ahead and increase the mutual inductance between the primary and secondary windings to any amount we please, or make it as great as we can, we could get a lot of amplification out of this system, perhaps almost as much as we could get out of that in Fig. 1. But here again we run into the snag of regeneration and self-oscillation; so we have to stop adding turns to the primary long before we have a resonance transformer whose efficiency is worth talking about.

In recognition of these failings of radio-frequency amplifiers, hundreds of methods of controlling regeneration and oscillation have been devised, but they are all more or less alike in the results they produce. Manufacturers of tubes have tried for a long time to build tubes with small internal capacities. But they found that, when they tried to reduce the intra-electrode capacities, they had to reduce the amplification factor at the same time, or raise the internal plate-resistance; so that it became a matter of "six of one and a half a dozen of the other."

THE "SHIELDED GRID"

Lately, Dr. A. W. Hull, of the General Electric Company, has devised an electron tube in which the capacity between the grid and plate is so small that it cannot be detected and measured by the most sensitive means. The means by which this was done were originally devised by Dr. Schottky, a German scientist. Instead of trying to remove this capacity actually from the tube (which, of course, would be impossible, since electrodes are required in the tube to make it operate) the effect of this capacity was eliminated by using what is known as the "shielded grid" principle.

The idea of this is to prevent, as far as possible, any of the electrostatic lines of force (which we always have between the plates of a charged condenser) from passing from the plate or any of its connecting wires to the grid or any of its connecting wires. This is done by placing between the grid and plate an electrostatic shield, which is given a certain bias and cuts off these electrostatic lines. At the same time this shield must be so arranged that it does not appreciably block the electrons as they flow from the filament to the plate; for it is upon the flow of these electrons that the operation of the tube depends.

There are two parts to the shielding. First, the grid itself must be shielded from

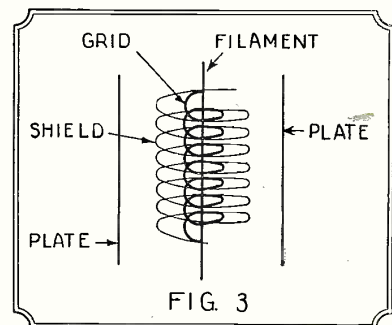

The principle of Dr. Hull's new tube, showing the position of the shield relative to the other elements.

the plate by an interposed shield. This shield may consist of a wire wound around the grid, the latter being of the coil type, and which is so placed that at every point the two coils of wire are opposite. This idea is illustrated in Fig. 3, which does not show the actual construction, but only the idea. Measurements made by Dr. Hull, however, showed that this type of shielding is not sufficient; as the wires must be so close together in order to obtain sufficient shielding that they intercept a considerable

proportion of the electrons flowing from the filament to the plate.

On account of this, the shield was made of thin, wide slats, placed edge-on toward the filament. In this way the shielding could be made very effective, without blocking any appreciable part of the electron flow.

LATEST IMPROVEMENTS

Next the supporting wires and the lead-in wires of the grid had to be shielded effectually from the plate and its supporting and lead-in wires. To accomplish this the grid was supported from the top of the tube. But, in spite of this, there are still some electrostatic lines of force which pass through space from the grid to the plate, and are likely to result in trouble. In order to intercept these the tube was covered by a grounded metal cylinder, fitting the tube closely; and finally a metal disc was attached to the top of the "screen-grid" and connected to the grounded cylinder. The accompanying Fig. 5 (taken from the *Physical Review*, in which Dr. Hull reports

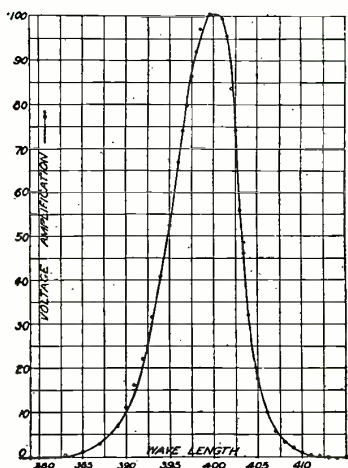

Selectivity curve of a 4-stage amplifier with input untuned, at 1,000 kc.

his work) shows the construction of the tube.

The static characteristics of these tubes are different from those of the ordinary tubes with which we are acquainted; but we will not go into these here, excepting to say that they differ mainly in the plate resistance. The effective capacity between the plate and the grid of one of these tubes was found by Dr. Hull to be 0.0278 micro-microfarad, contrasted with about 10 to 15 for the ordinary 201A type of tube. This amounts to a reduction of the grid plate capacity to about one five-hundredth of what we have in the 201A type of tube.

In testing out these tubes, the circuit shown in Fig. 4 was used. The screen-grids were maintained at 60 volts and the plates of the tubes at 110 volts. The output voltage of this radio-frequency amplifier

was measured by a calibrated detector tube.

The small voltage required at the input of the amplifier was obtained by connecting the input across a short piece of wire which was surrounded by a concentric return conductor. The input voltage was then equal to the reactance of this short copper rod multiplied by the current through it, which was measured by means of a thermocouple.

In making these measurements, Dr. Hull found that no advantage was gained by using any kind of a step-up transformer arrangement for coupling the tubes together. This is on account of the high plate-resistance of the tubes, which enables them to work efficiently into very high impedances, such as the type shown in Fig. 1; which was finally used, as the circuit of Fig. 4 shows. This diagram shows the complete connections of Dr. Hull's amplifier and measuring equipment.

ENORMOUS AMPLIFICATION

Some measurements made at 50 kilocycles, or 6,000 meters, showed that it was possible to obtain amplification of 200 per tube. When tested at medium frequencies, around

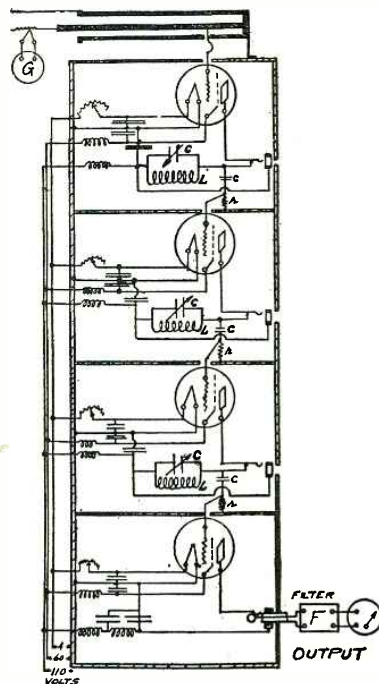

Fig. 4: Diagram of cascade amplifier used for tests at 1,000 and 10,000 kc. Input at upper left.

1,000 kilocycles, or 300 meters, they gave voltage amplifications between 40 and 45 when operated singly. When operated in cascade, two tubes were found to give an amplification of 1,700, and three tubes, of 75,000. In other words, at these frequencies an amplification of about 40 to 45 per tube

could be counted on. It is interesting to contrast this with the gain in our ordinary radio-frequency amplifiers, where we obtain not more than fifteenfold amplification.

As for the actual effects of such tubes on an audio amplifier, if we were to use them in a regular receiver, we must not forget that the detector operates according to a square law. That is, if we have a voltage e impressed on the detector, the output voltage of the latter is e^2 proportional to e^2 . Let us suppose that, in a very sensitive receiver of the ordinary kind, we can obtain a gain of 10 per stage. In Dr. Hull's receiver, a gain of 40 per stage can be obtained at 1,000 kilocycles. This is four times as great per stage. Suppose we consider three radio-frequency amplifier stages. This means an amplification 64 times that of our ordinary good receiver. And finally squaring this in the detector, we have an output from the detector which is 64×64 , or about 4,000, times as great as the output of the detector in the ordinary good receiver. And this means, that, barring static and other disturbances, it would be possible to detect signals 1/4000th as strong!

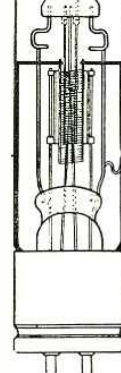

Fig. 5: Sketch of Dr. Hull's new tube, showing method of shielding the control grid from the plate.

Illustrations on this page courtesy of *The Physical Review*.

might have done if better filtering or by-passing of the R.F. had been obtained in the various stages.

At high frequencies, it is not possible to obtain such great amplification, since the resistance and dielectric losses are so large. This makes it difficult to obtain high impedance by resonance. At 30 meters (10,000 kilocycles), however, several tests were carried out, and a total amplification of 250 was obtained with five tubes. In another test, using special low-loss coils made of copper tubing, and other losses reduced considerably, the voltage amplification per stage was raised from three to seven; and it was found possible to obtain an overall amplification of between 10,000 and 15,000, using five tubes.

Tubes of this type, however, according to Dr. Hull's paper in the *Physical Review*, are not being manufactured, nor is their immediate production contemplated.

HOW THE DEAF HEAR RADIO

AT the International Psychological Congress recently held at Groningen, Holland, Professor Katz, of Rostock, read a paper asserting that the sense of touch is not a single sense, but consists of two distinct senses, one being a sense of pressure, and the other a "sense of vibration." The latter, he says, is the more primitive of the two, and probably older than the sense of hearing. That it is different from the sense of mere contact is proved by the fact that if we take a rod in our hand and use it to touch a piece of rubber or glass or metal,

we can distinguish between those substances without touching them directly.

Professor Katz describes some interesting experiments with a small cube of wood, to which he could impart a silent vibration of musical frequency. Anyone who touched the wood found it impossible to believe that he was not hearing a note, though if he did, it could only be by a sort of generalized hearing disseminated all over the skin. Experiments made with Sudermeister, a deaf mute of Berne, showed that he could "hear" music through his spinal column.

Some forms of music, and some particular notes and chords, convey a definite "shock," which we have probably all experienced at some time or other, says Dr. E. E. Fournier d'Albe. Some savages plant their legs apart when they want to judge the direction of a sound coming through the ground. The two legs in an appropriate position receive the impulse at different times, and a difference of even a thousandth of a second suffices to give the impression required to judge the direction of a sound.

The Effects of Shielding

A Study of the Electrical Changes Produced in R.F. Circuits by Metal Shields

By HAROLD A. ZAHL



ONE of the greatest changes that we see in radio construction is the increasing vogue of complete shielding of the high-frequency units. One by one the manufacturers are falling in line, while few people any longer consider building a receiver without shielding. The theory of shielding is not very complex. Those familiar in any way with the theory of electromagnetic waves are well

reduced to somewhat less than 90% of its original value. This drop may be considered negligible but, as the shield is brought closer, the absorption increases rapidly. Closer than one inch the effect is a great reduction of efficiency. Fig. 2 shows the average curve obtained using a tuned intermediate transformer. This curve is quite similar to that of Fig. 1, but the drop is not quite so rapid.

The differences in the settings of the different condensers, providing the condensers are matched, are directly proportional to the drops in voltage transmitted. This may also be remedied by shifting the shield sufficiently (the direction to be determined by experiment) to bring the dial settings together.

CAPACITY CHANGES

The creation of eddy currents is not the only effect of shielding. A shield in the field of an R.F. transformer may give the effect of a series capacity, which raises the resonance-frequency of the unit. Thus the placing of a shield close to the transformer, in its field, may completely alter the natural resonance-frequency of the condenser-coil unit. This shifting of the resonance-frequency is first noticed from the reduction of the voltage transmitted, and increases as the shield is brought closer to the transformer.

If the shields are too close to the windings, in the case of tuned intermediate transformers, the entire cascade may be thrown out of tune and poor signal transmission will result. The effect is the same as though the intermediate-transformer unit was not matched. Strangely enough, this same phenomenon may be made use of in

PROPER PLACEMENT OF SHIELDS

In the case of both radio and intermediate transformers, if the units are pre-

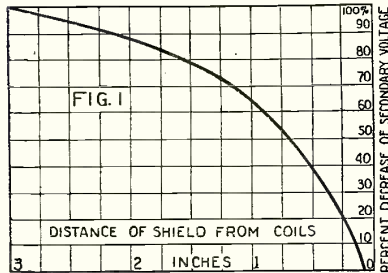

Curve showing the absorption effects at different distances, when a shield is introduced perpendicular to the magnetic field of a R.F. transformer.

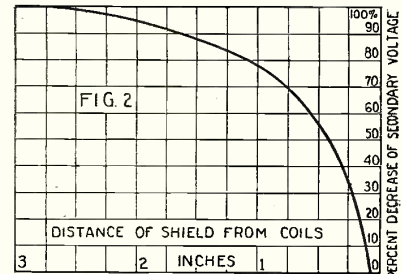

Curve showing decrease of secondary voltage with increasing proximity of a shield to the end of an I.F. transformer.

acquainted with the fact that two waves of different radio frequencies, in combining, produce a resultant wave which often interferes with the proper operation of a receiver. Suppose the receiver is tuned to a frequency of 1,000,000 cycles (per second) which corresponds to a wavelength of 300 meters. A second wave of 995,000, or 1,005,000 cycles, if impressed upon the wave of 1,000,000 cycles, will give a beat-frequency of 5,000 cycles, which is well within the audible range and will be heard in the loud speaker as a squeal.

This second, or interfering wave may be due either to internal oscillations within the set itself or to a second broadcast station. While shielding has to do in great part with eliminating the interference due to external sources, it can also be used to prevent interstage coupling in a tuned R.F. receiver.

LOSSES CAUSED BY SHIELDING

It is frequently the case that a constructor, in shielding his set, fails to realize that shielding may be harmful as well as beneficial. Grounded shields in the field of a radio-frequency transformer, if too close to the end of the coils, show an absorption effect and greatly diminish the current transmitted. The cause of this effect is that the grounded shield acts as a closed conductor in which small voltages of different values are induced in different parts of the alternating field, giving rise to eddy currents. Energy thus consumed by these induced currents is wasted in heating the shield, thus reducing the efficiency of the unit.

Fig. 1 shows graphically the absorption effect as the grounded shield is brought towards a radio-frequency transformer, the shield being at right angles to the field. Different transformers with different windings produce slightly different curves; but the curve in Fig. 1 shows a close approximation to the curves of the average transformer. Thus we see that a shield three inches from the windings does not appreciably reduce the voltage transmitted; but, at two inches distance, the voltage is

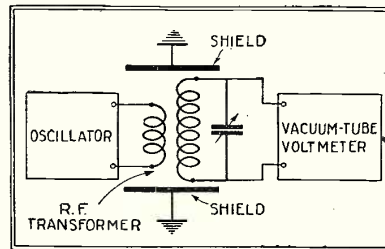

A general layout of the apparatus used to obtain the curves shown in Figs. 1 and 2.

matching intermediate transformers. Proper adjustment of the shield in the field of the faulty transformer will often result in so changing its frequency as to correspond with the average frequency transmitted by the rest of the transformers.

In the case of radio-frequency transformers, the effect is essentially the same, but is noticed in the non-synchronization of

viously matched, this adjustment will not be necessary if the shields are kept the proper distance from the coil windings. In no case should a shield be closer to the windings than two inches. Shields not in the direct field of the transformer show an absorption effect directly proportional to the amount of surface exposed to the magnetic field. A shield lying in a plane parallel to the core shows practically no absorption effect. If the primary and secondary windings are separated some distance, the voltage drop will be practically the same as shown by the curves. But the resonance-frequency will not change appreciably as the shield is brought towards the primary winding.

METHODS OF MEASUREMENT

In obtaining the curves shown herewith, the following instruments were used: vacuum-tube voltmeter, wavemeter, radio-frequency and intermediate-frequency oscillators. The transformers used in obtaining characteristics were selected to cover several features, which different commercial transformers possess, pertaining to cores and windings. No particular type of trans-

(Continued on page 66)

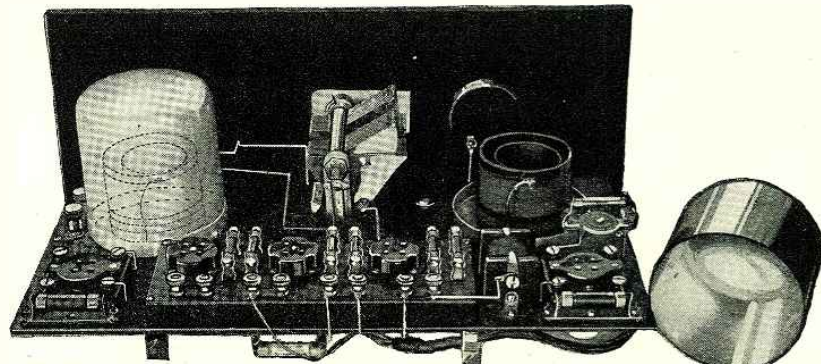

An R.F. transformer is shown in phantom view within the shield at the left, to illustrate the proper proportions between coil and shield; at the right, the cover removed from coil.



Correspondence from Readers



EFFECTS OF THE AURORA

Editor, RADIO NEWS:

Just a word about the Northern Lights (aurora borealis). It seems to me there are two kinds. They come right over my house and as a rule form a centre about midnight, then slowly fall back, as far as the eye can see east and west. This display does not affect reception very much, to my mind. Now, the one that does is the low, bank-like kind which stretches only half-way from east to west.

About the tenth of March a neighbor's radio set was electrified by what appears to have been an "electric shower." He went to tune in and got a shock. Thinking the batteries might have been shorted, he disconnected the leads, first from the set and then from the batteries. He then took off the ground, and the sparks continued until he took off the aerial.

There was no lightning arrester on the set. The thermometer was near zero, with a clear sky. The phenomena lasted fifteen minutes or more.

W. J. GATLEY,

Austin, Manitoba, Canada.

(The aurora is more pronounced in northern latitudes; and displays of atmospheric electricity in cold, dry air. An insulated aerial, which forms one plate of a condenser (the other being the ground), will charge to a high degree with positive electricity, when the atmosphere is dry and especially non-conductive.—EDITOR)

COMPARISONS OF RECEPTION

Editor, RADIO NEWS:

It is not the purpose of the writer to "cold shower" any person's enthusiasm for his pet hook-up; but a recent letter in the Home Set Constructors' column for May, on the "Mystery" circuit, reminds him of trying it out, without much to boast about.

When we feel like raving about the distance-getting qualities of our pet hook-up, there is something else to consider: first, the atmospheric conditions which will permit your getting stations 1,500 miles distant one night, while stations of the same power 500 miles away cannot be heard on the next, or for a week or more.

Secondly, so many stations have increased their power that any single-tube regenerative set with a good aerial will give fair headphone volume from at least 25 stations east of the Mississippi River on an average of five nights a week from a central location such as this.

The winter of 1925-6, the writer with a one-tube (199) set could pick up Jacksonville and Clearwater, Fla., Chicago, St. Louis, Springfield, Mass., only one or two stations in New York, and many others almost any night. Florida kept coming in clear until the middle of May.

A great hook-up is one that will perform exceptionally well on good nights and relatively well on poor ones; soldered joints, tight connections and reasonable care in insulation will do the trick. When considering how good a hook-up is, make comparisons on stations of like power, like distance, under like weather conditions. It may be found that it is not a "phenom" at all, but "just another," which the "Mystery 127" proved to be when the writer tried it out about a year and a half ago.

W. C. GORDON,

1068 Market St., Wheeling, W. Va.

LIST OF BROADCAST STATIONS

SHORT-TERM licenses have been issued by the Radio Commission to about 700 broadcast stations, to permit their operation while the permanent allocation of frequencies and maximum power is being determined. To publish this list would be misleading, however, as it will be altered considerably before this magazine reaches its readers. It is believed, however, that the great majority of the permanent licenses will be granted by June 15; and RADIO NEWS hopes in its August issue to give its readers a reference list of station calls, wavelengths, and power which will be subject to little further change.

SCIENTIFIC HYPOTHESES

Editor, RADIO NEWS:

It is really a pleasure to me to read the highly interesting articles that appear in RADIO NEWS, which, it can be said, are the last word concerning radio; and in countries like this, which follow, we can say, entirely the American standards, are the handbooks of many Argentine set designers. Having declared what, in my opinion, is only just to say, I turn to the motive of this letter.

In an article entitled "Visible Radio Waves" (January, 1927), Mr. Clyde J. Fitch opens fire thus: "During the process of evolution, man has acquired a few highly-developed senses by which his limited knowledge of the external world has been gleaned—those of sight, sound, touch, smell and taste." Well, coming down to brass tacks, that sentence is written as though evolution were a universally-recognized fact, which is by no means the case. If Mr. Fitch is a believer in that theory, everybody else is not. In my opinion, if Mr. Fitch desired to say or discuss anything on the subject, he would do well to do it in a book, or if he preferred it so, in a review or magazine that goes in for that kind of stuff—not in RADIO NEWS, which has no concern but with radio material.

CHARLES A. J. ROGERS,
Buenos Aires, Argentina.

(While the theory of evolution cannot be said to be proved in the sense, for instance, that that of gravitation has been, it is nevertheless the one most generally accepted, with various modifications, by scientific men; although, as our correspondent observes, it is not especially germane to the article. It may be of interest to remark that the

OUR worldwide army of readers sends in many letters daily, all of which RADIO NEWS is glad to receive; but few of them can be printed on this page. In making a selection, preference is given to those containing novel information; and then to those most concisely presenting opinions on various phases of questions of general interest, reflecting different points of view, without regard to whether or not they are those entertained by the editors. All letters should contain the writer's complete address, that they may be acknowledged or answered, if not published.

article was based upon another theory which is still open to the influence of opposing observations—that of "ether waves." There is evidence, of a strong positive nature, which has not been yet explained away, against the undulatory theory of magnetic radiation; while that against evolution is purely negative. Yet we speak familiarly of "wavelengths," and reckon by them in practical affairs, until a more satisfactory explanation is available, notwithstanding our doubts as to the correctness of the illustration.—EDITOR.)

FROM A SCEPTIC

Editor, RADIO NEWS:

I always thought I was the biggest liar in the world; but, after reading letters from DX fans in the May issue, I pass—that's all there is to it, I pass!

But I am not going to lie down and give up the ghost without a struggle; so here goes a bona-fide open challenge to the whole blamed world, if you care to print it.

I have built everything from a crystal set to an eight-tube superheterodyne (Victoreen) I am now using; and I have not been able to tune in Japan, China, nor heaven, as a lot of these birds do regularly. I here and now offer to deposit a certified check for \$500.00 in any bank in the city, payable to the fellow who can show me any set that will outperform this in distance, volume, selectivity and quality.

Now, all of you, including Mr. T. G. Mann of this city, who had one of these pipe dreams published in that issue, either produce or stay within the bounds of reason.

F. C. STAVES,
331 52nd St., Des Moines, Iowa.
(Drake 8257W)

(The contest proposed by Mr. Staves should be an interesting one; perhaps some of his DX-getting neighbors will be willing to take him up. We await the returns.—EDITOR.)

LICENSES FOR RADIO SERVICE MEN?

Editor, RADIO NEWS:

My work is service, and I cannot help but laugh at the way some readers slam the service man. Yet we must admit that a lot of good money is spent by the fan for service that he does not get. Why? Chances are he has hired one of the so-called "kitchen-sink mechanics": then the whole radio service profession is cursed.

The radio jobber or wholesaler can do much to overcome this menace by refusing to furnish parts to these "pirates." Another way would be to have a radio service men's union and require all repairmen to join or go back selling washing machines again. The customer can do his share also by allowing only certified radiotricians to work on his set. Also, why not have the dealer hire only first-class men for service work? A little teamwork will help everyone concerned.

GEORGE LUCKEY,
6250 So. Halsted St., Chicago, Ill.

(A number of letters have presented the same problem—how is the set owner to be assured that his set is in competent hands? Some have suggested that the Radio Commission examine and license repairers—

(Continued on page 79)



Letters from Radio Home Set Constructors



SEVENTEEN TUBES IN THIS SET

Editor, RADIO NEWS:

I think other experimenters may be interested in this set, which newspaper men in this section pronounce one of the most powerful in use. It is a superheterodyne, five feet long and 30 inches deep (I do not believe in crowding parts, especially in a large set), completely shielded, and operates from 110-volt A.C. There are two "B" and one "A" power units. The weight of the outfit approximates 200 pounds. It is designed to cover the waveband from 35 to 1,000 meters, and is very selective. I use an aerial 300 feet long and 60 feet high. Including the rectifier tubes and the three power tubes, which are built into the Western Electric loud speaker (separate from the set) there are 17 tubes.

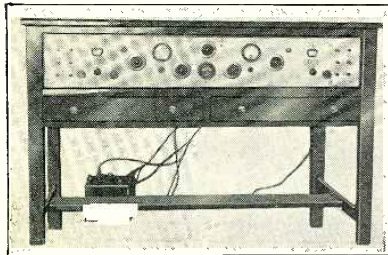

This receiver is five feet long. The illustration shows the numerous controls, but fails to bring out the beauty of the ivory, gold and black panel array.

I enclose the diagram. The instruments used are not standard, so I will furnish values to anyone who is really interested, so far as I can—some I do not know myself.

All A.C. wires run in metal tubing, which does away with all hum. The aerial circuit is tuned by a single condenser, and the other R.F. and first detector circuits by a three-gang instrument. All these controls have proper verniers and compensators. The coils are of the plug-in type. As the photograph shows, the set is provided with an elaborate system of control; by means of switches it may be changed from a regenerative to a T.R.F. or a superhet, using from four tubes up. Though it may seem strange, 135 volts "B" is used on the plates of the R.F. tubes. Lighting is provided at the rear of the set in making adjustments, as well as panel lights. While this set is too complicated for use of the average listener, when I hear the average set perform, I cannot but feel that it would be worth anyone's time to build and learn to operate such a receiver as this. The speaker has that pleasing tone for which the new Orthophonics are noted, and can be controlled from a whisper to a roar loud enough to be heard half a mile away; its

rule, the stronger the incoming signal, the greater the distortion. In other words, Mr. Schnell is getting nearly as much distortion in the output of the second detector as most six-tube sets do in the output of the second A.F., where three A.F. are used. This is taking it for granted that the three A.F. stages in question are practically free from distortion.

The question of distortion in audio amplifiers is something else again. My choice is three stages of resistance-coupled with a bias battery on each grid. The grid must not become positive at any time and the plate current must not be reduced to zero at any time. These requirements apply to any type of amplifier made; personally I think they include R.F. as well as A.F., although distortion is less noticed in the R.F.

Transformers and impedances are made so that there is little distortion present in them. But the tubes and batteries must be suited to the voltages which occur when the strongest signal is received. Otherwise distortion.

Yours truly,

HARRY S. BIXBY,
Gowanda, N. Y.

A MAN'S-SIZED PORTABLE

Editor, RADIO NEWS:

I have read with interest about every portable set that I have seen described in print; and resolved to build the most powerful, sensitive and compact receiver that I could. I settled on a standard hook-up, Gerald M. Best's improved 45-ke. superheterodyne, described in the Radio News Superheterodyne Book; using CX-299 tubes except in the last stage, where I found a CX-220 power tube more satisfactory. The total "A" consumption is just a fraction over half an amp.—think of that.

I found a plain suit case that met my requirements; it is lined with wood, inside dimensions 8 inches deep, 12 3/4 inches high, and takes a panel 7x23 3/4 inches. I removed the lid and ordered from the firm two draw fasteners like those on top. These were placed near the bottom at each end. I raised the base board and used only 5 inches for the receiver; this gave more room in the bottom for the batteries, as well as the loud speaker, which has a Utah unit. Six or eight dry cells are used for "A" batteries, 3 45-volt "B" batteries, and the power tube is biased with another. I can use a storage battery to light the filaments by throwing a small D.P. D.T. switch on the left end of the panel.

On the panel is a voltmeter, and directly under it a Bradleystat, which controls the filaments. Remler parts were used throughout and Universal sockets.

I built a loop and fitted it nicely in the lid; it worked, but I discarded it for a signal loop, which collapses and fits nicely in the lid when closed. However, with the built-in loop, I could tune in a station, walk up the street, and the station would come in as long as the loop pointed toward it. Living in southern Kentucky, near the Tennessee

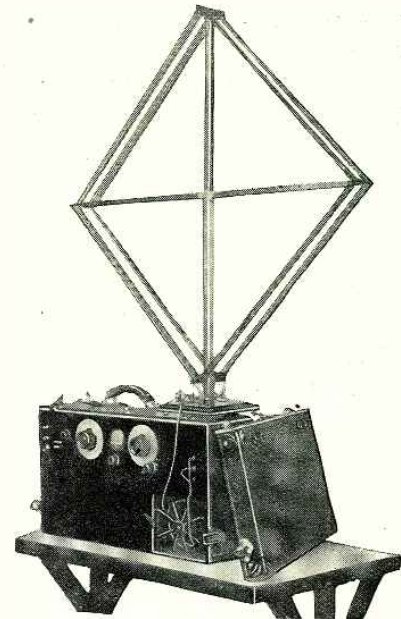

All builders of portables are not as ambitious as Dr. Gray, who has constructed the largest portable of which he has heard—and carries it himself. It weighs 51 pounds!

line, I am able to tune in KSD every hour for the market reports, as well as KYW, WLW, WHO and other stations in daylight. While the receiver is no better than those built up in other styles of cabinets, it is powerful, compact and sturdily built, completely self-contained and portable. A feature I like about it is that it is less conspicuous, as it has the same appearance as other luggage.

J. G. GRAY, M. D.,
Franklin, Kentucky.

INTERMEDIATE AMPLIFICATION

Editor, RADIO NEWS:

I wish to call particular attention to the second paragraph of the article in the May issue of (Continued on page 80)

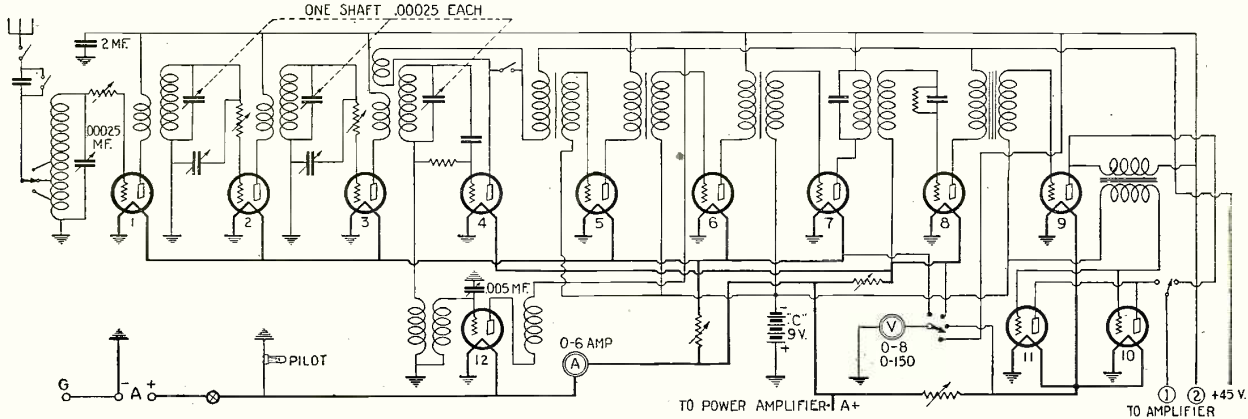

Circuit of Mr. Utz' big receiver, with the power amplifier at lower right. The power unit with the two rectifier tubes is omitted.

tone holds those who hear it for the first time speechless with wonder. If any readers do not find this description sufficient for them, I will attempt to answer all letters.

WILLIAM C. UTZ,
93 Liberty St., Westminster, Md.

AVOIDING DISTORTION

Editor, RADIO NEWS:

It was with great interest that I read the article on "Are Audio Amplifiers Too Numerous?" by E. A. Schnell in the February issue of RADIO NEWS. I do not quite agree with all Mr. Schnell says.

Looking at the characteristic curve of a detector tube, it can be seen that the plate current does not vary evenly with the grid voltage. As a

LETTERS for this page should be as short as possible, for so many are received that all cannot be printed. Unless a set is made from a published description, a schematic sketch should be sent; photos can be used only to illustrate a novelty, and then only if large and very clear. Inquiries for information not given here should be sent to the constructor direct. This page is for free discussion to the extent that space permits; but RADIO NEWS accepts no responsibility for the opinions of readers as to the relative merits of apparatus and circuits.

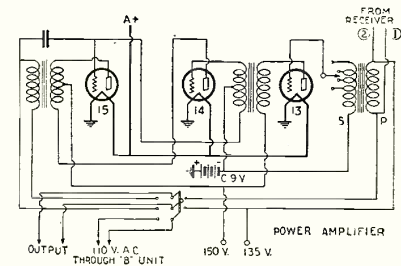

Radiotics

SOME FEEDING

This from the March, 1927, issue of *Broadcasting Magazine*: "The second bag contains 'A' and 'B' batteries TO FEED THE AMPLIFIER, THREE MICROPHONES, HEADPHONES, MIKE EXTENSION CORDS, WIRE AND TOOLS." We didn't know that it was necessary to cater for the latter articles. Live and learn.

Contributed by Wm. Lemkin.



WHAT NEXT?!

From the *New York Telegram* of March 29: "Broadcasting from radio stations in the vicinity of New York and along the are blamed for the FALLING BIRTHRATE of night from 11:30 to 12:19" We have heard radio blamed for a lot of things, but this is a new one on us.

Contributed by John Pristas.



MORE PROGRESS

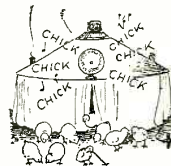

Further accomplishments of radio engineers are told in the March *Engineering Works Review*: "Incubator: For sale or trade a Hot Air Incubator, 130-egg capacity complete with instructions for a radio." Mike of the investigation department went out on this job and reported that the radio waves caused the eggs to hatch more quickly than nature's method. Ain't science wonderful?

Contributed by Roland R. Smith.

A REAL CHAISE LONGUE

In describing hook-ups of several Canadian stations, the *Syracuse Herald* of April 7 announces that "the CHAIR reaches from coast to coast." We can't imagine what a seat of these dimensions can be good for, unless the flaming youth of Canada has outgrown the back seats of automobiles.

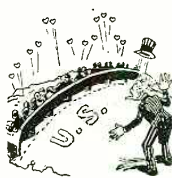

Contributed by K. W. Schwartz.

TELEVISION OUTDONE

On March 20 the *Boston Herald* made this statement: "At a small investment any PHOTOGRAPH may be converted into an instrument of new musical results." What a splendid use for the old family album with all the speaking likenesses! Imagine Uncle Zeph and Aunt Hepzy in the Angel's Serenade! The dear departed can no longer rest in peace.

Contributed by L. W. Newell.



TOUGH ON THE LISTENERS

The *Radio Dealer* of March says, in regard to the necessary rearrangement of broadcast stations: "It will require some PATIENTS on the part of listeners while the Commissioner works out the problem." We don't doubt that some of the tangles of the radio waves have made a lot of people awfully sick.

Contributed by W. A. Jones.

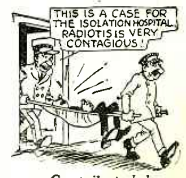

MEOW!

Feline gesture from the *Detroit News* of April 6: "BROADCAST range to remain same." Mike of the Investigation Department telegraphs from Washington that the Radio Commission is to allow the back-fence melodies to remain unchanged and uncensored. Tough, ain't it?

Contributed by Gerald Covell.



If you happen to see any humorous misprints in the press we shall be glad to have you clip them out and send to us. No **RADIOTIC** will be accepted unless the printed original giving the name of the newspaper or magazine is submitted with date and page on which it appeared. We will pay \$1.00 for each **RADIOTIC** accepted and printed here. A few humorous lines from each correspondent should accompany each **RADIOTIC**. The most humorous ones will be printed. Address all **RADIOTICS** to

Editor **RADIOTIC DEPARTMENT**,
c/o Radio News.

JUNK THE SOLDERING IRON



From a testimonial letter sent out by a manufacturer: "Just recently I had the opportunity of seeing one of the **BLUE-PRINTS** on the Super-10 and also **HEARING** one and was favorably impressed with the **CLEARNESS** and **TONE** quality." What's the use of taking the trouble to build sets, when you can hook-up the blue-print of the circuit to the loud speaker and get the same results?

Contributed by Harry McLatchy.

AID FOR THE AUTOIST

A gem from the *Jackson (Mich.) Citizen Patriot* of April 1: "Loud speakers \$6.95. FOR ALL CARS, ACTS AS MUFFLER OR CUT-OUT." Maybe you can put a loud speaker in series with the exhaust of your car, and it will improve the tone of your driver.

Contributed by R. E. Wheaton.



NEW ELECTRICAL INDUSTRY

From an announcement in the *Bay City (Mich.) Times Tribune* of March 13 of a new radio tube it appears that "the tube is being manufactured in the **LAMB** works of the General Electric Company." Now we know why the sets using tubes like this make such funny noises.

Contributed by Clarence DeBats.

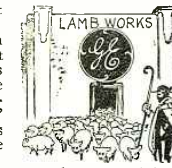

FORTY-THOUSAND LUNG-POWER

Interesting data on quality of reproduction compiled by "What Set Shall I Buy?" concerning a lamp-socket operated receiver: "Overall **DIMENSIONS** receiver length 27 inches." This should be just the set to tune in with on a big-league game; you would get the full effect of the crowd's enthusiasm when Babe socked one on the trademark.

Contributed by T. L. Doran.



TOUGH ON THE BATTERY

In the *New York Sun* of April 9, under the head of advice on charging the battery it is explained that the operator "may **BLOAT** the battery on the line at all times." Our idea of anything fat or bloated is something which is incapable of much exertion. However, the owners of some batteries may be too big-hearted and under-exercise their apparatus.

Contributed by Paul V. Heine.



NOT FEMALE STATIONS

Exposure in the *Free Press* *Prairie Farmer* of Winnipeg, Manitoba, of March 9: "A number of low **POWDERED** radiophone transmitters have been installed in British Columbia." From this it seems that the Canadian stations are distinctly of the stronger sex, since they disdain the use of excessive beautifiers. However, you never can tell, nowadays.

Contributed by Cornelius C. Enns.



YES, WE HAVE 'EM TODAY

Note on set building in *Popular Wireless* (London) of March 5: "Many of us found that two stages of A.F. gave the loud speaker what the Americans call **'BANANAS'**." We have started Mike, our faithful investigator, out on the fastest boat to get the full details; radio may yet make us indifferent to the daily political rotations in the banana belt, if this scheme works out.

Contributed by F. L. Erickson.

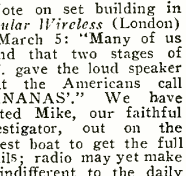

ATTENTION, CHEFS!

From the *Poughkeepsie (New York) Sunday Courier* of April 3rd, we glean this advertisement: "For sale, **FRIED** Eiseman radio in console cabinet." We can't help but wonder if this particular set is fried on both sides, and if it would be a good buy for the hard-boiled radio fan.

Contributed by Carrie T. Briggs.



RAISE YOU FIVE

Radio applied to the popular American indoor sport, as revealed in *Radio Doings* of March 12th: ". . . may have the set revived so that the new power amplifier tube and the socket **POKER** equipment may be used." This seems about the safest way to play poker, so as not to lose any money; that is, by the absent treatment.

Contributed by D. J. Cunningham.

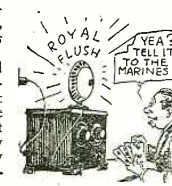

A PERFECT TRAINING

The *New Haven Register* of March 13 printed the following information concerning the education of a prominent announcer: "At college he took honors in oratory besides **SPEALIZING** in languages." What better course could an announcer take than in speaking? (Colleges please take notice.)

Contributed by S. L. Cooke.





First Prize

SET CONNECTOR

By W. T. R. PRICE

WITH this multiple plug the radio set may be disconnected or connected as easily as an electric flatiron, and with no possibility of making a mistake.

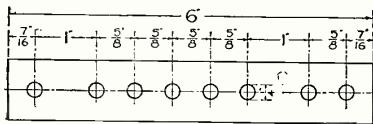

FIG. 1

Drilling details for the bakelite strips, shown in Fig. 3.

Procure two strips of 3/16- or 1/4-inch bakelite, 1 inch wide and long enough to carry the desired number of tip jacks of the type illustrated. The writer used eight jacks in a strip six inches long. After laying off the centers on one of the strips, as shown in Fig. 1, place the two strips together and clamp in a vise in such a position that all

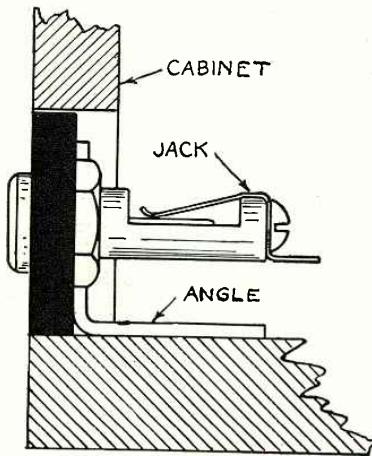

FIG. 2

The method of mounting the strip, using angle brass.

holes may be drilled in both strips without removing from the vise. Drill through all the centers first, with a No. 34 or 36 drill for a pilot, and follow this with an accurate 1/4-inch drill. Now remove the strips from the vise and redrill one of them with a 3/8-inch drill. This method will give perfect alignment of holes, which is essential. Now remove the knurled nuts "B" (Fig. 3) and force the tips, point first into the 1/4-inch holes as far as the knurling at the end of the tip. The jacks are then assembled in the other strip in the regular way. Turn the nuts up snug, with flat sides toward each other to give more clearance between nuts.

Prize Winners

First Prize \$25
A SET CONNECTOR
 By W. T. R. PRICE
 Scarborough, N. Y.

Second Prize \$15
LOUD-SPEAKER SWITCH
 By MARION HARTLEY
 No. 41, R.F.D., Gasport, N. Y.

Third Prize \$10
RADIO DIALS FOR THE BLIND
 By FRED W. MORRIS
 124 Sherman Ave., New York, N. Y.

All published Wrinkles, not winning prizes, will be paid for at the rate of two dollars each.
 The next list of prize winners will be published in the September issue.

It now remains to attach the jack strip to the base board of the set by means of two

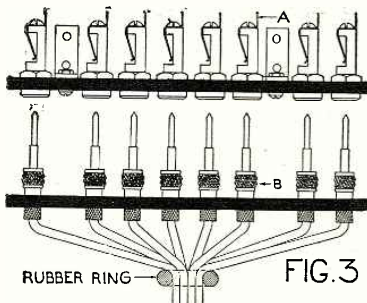

The strips supporting the plugs and jacks are here shown. By spacing unevenly the end plugs it is made impossible to insert them the wrong way.

brass angles, as shown in Figs. 2 and 3. These are unevenly spaced to prevent insertion of the tip strip wrong end to. The lugs "A" (Fig. 3), are now soldered to their respective terminals in the set, and the tips are connected to batteries, antenna and ground by means of flexible lamp cord of suitable length, which may be cabled or not as desired.

Second Prize

LOUD-SPEAKER SWITCH

By MARION HARTLEY

FOR easy comparison of the quality of loud speakers, this switch permits instantaneous change over from one to the other. The contrast at once impresses the ear.

The parts required are four Fahnestock

connectors, two switch points, a piece of hard rubber about 2 1/2 x 1 inch, cut from an

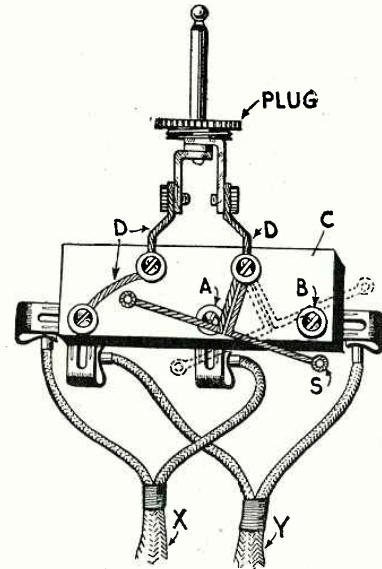

By throwing the bus-bar switch, S, from A to B (switchpoints) a second speaker can be heard almost instantaneously. C, insulating panel; D, bus-bar; and X and Y, speaker connections.

old panel, three screws and nuts, washers, an old plug and a short piece of bus bar. The construction is simple and the connections can be seen readily from the diagram.

Third Prize

RADIO DIALS FOR THE BLIND

By FRED W. MORRIS

A RADIO broadcast receiver is an especial blessing to blind people, who can obtain amusement and diversion by few other means. However, it is often difficult for such persons to handle the dials on their sets, as they cannot see the markings.

If you have any blind friends experiencing trouble from this source, you can easily fix their dials in such a manner that they will be able to "read" the settings with their fingers. The idea is simply to drill tiny holes at the "tens" divisions and to push in the heads of ordinary pins in the arrangement indicated in the drawing. The ends of the pins, protruding through the backs of the dials, are cut off flush, so that they will not interfere with the rotation of the latter.

The pin markings illustrated read: 0-1-2-3-4-5-6-7-8-9-0, according to the New York point system for finger reading. (See top of next page.)

BROADCASTING AT HOME

AFTER listening to a radio concert for a few hours, no doubt it has occurred to many to ask themselves the question, "I wonder how my voice would sound over the radio?" but, having no particular talent to

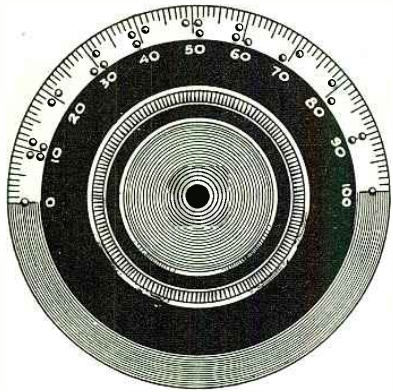

A tuning dial for blind persons can be easily made by inserting common pins at each number as shown. (Third prize.)

offer, we are forbidden the opportunity of broadcasting. But, if you are the owner of a cone loud speaker, or a pair of Baldwin earphones, it will not be a difficult thing to hear yourself as others would hear you over your radio receiver.

Of course, there are many ways of connecting a regular microphone to the audio amplifier of your set, and thus hearing your voice on the loud speaker; but a broadcasting "mike" costs about eighty dollars, and a telephone "mike" is unsatisfactory because of its poor modulation, so we see such methods are prohibitive to the average pocket-book. However, we need not be discouraged; for we may obtain modulation as flawless as that of the best broadcasting stations without any apparatus other than comprised in most every radio receiver—namely, two stages of audio amplification and a cone speaker (or Baldwin unit).

The connections are simple, and no wires whatever need be changed in the set. Merely connect one terminal of the cone

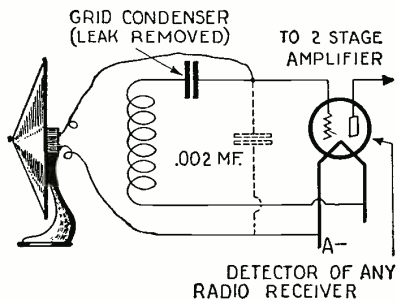

By inserting a loud speaker, as shown above, it is possible to amplify your own voice, and other sounds in your home, through your receiver.

speaker directly to the grid terminal on the detector socket, remove the grid leak and connect the other terminal of the cone speaker to the "A-." Probably it will be necessary to replace the soft detector tube by a 201A type; in which case the detector "B" voltage should be increased to 45 volts or more. If the earphones are now plugged in the last stage and the set is turned on, the cone speaker will pick up any sound in the room and it will be

heard amplified clearly and without distortion in the earphones.

The volume is sufficient to operate a loud speaker, but if this is done, the cone speaker must be in another room from the loud speaker reproducing the voice or music. If a 60-cycle hum is picked up by the cord running to the cone, it may be eliminated by using double twisted wire, and connecting a fixed condenser of about .002-mf. across the terminals of the cone (as shown in dotted lines). The same result is obtained with an earphone, but, unlike the cone which will pick up any sound within the room, it will necessary to speak directly into the phone.

The aerial wire should be disconnected from the set to prevent any radiation, which, of course, could take place only in a regenerative set.

—Contributed by Donald Sheets.

STORAGE BATTERY CARRIER

A HANDY battery carrier can be made from a bundle carrier and two of the brackets used to support window shade rollers. The brackets should be placed upon an iron pipe and the right-angled bend beaten into a round shoulder, so that the handle of the storage battery will rest firmly in the bend. The attachment of the luggage or bundle carrier to the lugs thus formed can be made with heavy wire. The transporting of the storage battery is thus

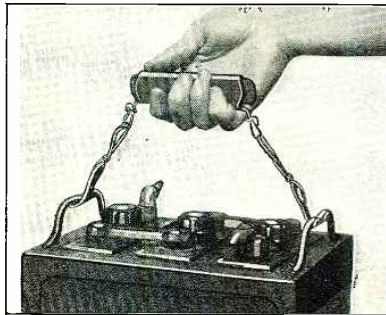

An easily made carrier for a storage battery is illustrated above.

changed from a very difficult task to a one-handed affair.

Contributed by Raymond B. Wailes.

HEATING SOLDERING IRON

WHILE a gasoline blow-torch is the easiest and best method of heating a soldering iron, it often happens that this cannot be procured at a time when a job of soldering is to be done. The usual method of heating an iron on the farm is to put it in the stove, where it soon becomes quite hot enough; but not until a harmful brittle scale is formed, making it difficult to do a good job.

A very convenient method of getting around this difficulty is to cut a short piece of iron pipe, of sufficient diameter to take a soldering iron, to a length of about eight inches. A threaded cap is fitted on one end of this tube. It may now be thrust into the fire and coals heaped around the closed end, with the open end inclined

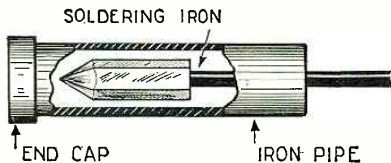

If you place your soldering tool in an iron pipe like the above, scale will not form on the iron as when heated in an open fire.

toward the door of the stove. Now, when the iron is thrust into the pipe it is quickly heated, without the formation of the heavy scale which results if the copper comes in direct contact with the coals.

Repeated heatings require only that the iron be thrust into the pipe for a moment, as the pipe holds a red heat which is quickly imparted to the iron.

—Contributed by Floyd A. Meek.

TEST CLIP

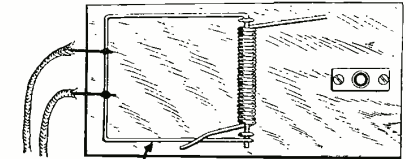

The copper wire of a mouse trap makes a good gang connector.

A COMMON mouse trap makes a good laboratory test clip. It is sufficiently large to hold a dozen wires at one time, if desired.

—Contributed by L. A. Collins.

REMOTE SET CONTROL

IT is often convenient to be able to listen to radio programs by means of an extension cord to the bedside or other part of the house; but its disadvantage is that one has to go down to the set to turn it off. This trouble can be overcome by means of a four-wire extension cord, having one end connected to a double-circuit filament-control jack, which may be screwed to the side of the cabinet or radio table, and at the other end a single-circuit filament control jack with connections as shown in the diagram. The set can then be turned on or off by pulling out the loud-speaker plug, which should be of the volume-control type.

When the set is to be used in the ordinary way (without the extension) and the filament circuit happens to be turned off at

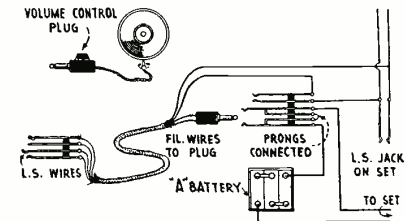

How the filament circuit can be controlled from a distant point.

the far end of the extension cord, it may be turned on again by pulling out the extension plug at the set. The wires should be heavy-gauge and the rheostats turned full on to make up for resistance in the filament circuit.

—Contributed by R. Dove.

A HANDY COIL WINDER

ACCURATE space-wound coils can be made by the experimenter or home builder with very little more trouble than with the usual close-wound type.

The thin sides, "A" and "B," of the small wooden frame press lightly against the spools to create the desired tension when winding. Heavy button thread is about right for spacing, but the size of thread or string used may be varied to give any spacing desired. When the coil is wound and the wire secured against loosening, the thread is removed. With no winding apparatus at hand the experimenter

(Continued on page 83)



Radio News Laboratories

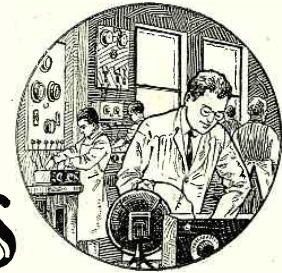

RADIO manufacturers are invited to send to RADIO NEWS LABORATORIES, samples of their products for test. It does not matter whether or not they advertise in RADIO NEWS, the RADIO NEWS LABORATORIES being an independent organization, with the improvement of radio apparatus as its aim. If, after being tested, the instruments submitted prove to be built according to modern radio engineering practice, they will each be awarded a certificate of merit, and a "write-up" such as those given below will appear in this department of RADIO NEWS. If the apparatus does not pass the Laboratory tests, it will be returned to the manufacturer with suggestions for improvements. No "write-ups" sent by manufacturers are published on these pages, and only apparatus which has been tested by the Laboratories and found to be of good mechanical and electrical construction is described. Inasmuch as the service of the RADIO NEWS LABORATORIES is free to all manufacturers whether they are advertisers or not, it is necessary that all goods to be tested be forwarded prepaid, otherwise they cannot be accepted by the Laboratories. Apparatus ready for the market or already on the market will be tested for manufacturers, as heretofore, free of charge. Apparatus in process of development will be tested at a charge of \$2.00 per hour required to do the work. Address all communications and all parcels to RADIO NEWS LABORATORIES, 230 Fifth Avenue, New York City.

VACUUM TUBE

The "Keen Tone X-112" tube shown, submitted by the K T Products Co., 68 William St., New York City, is of the power type, to be used in the last audio stage. It is equipped with a duplex base and may be used in any radio receiver. The correct "B" and "C" voltages may be obtained by connecting ad-



ditional batteries to the binding posts on the rim of the tube. AWARDED THE RADIO NEWS LABORATORIES CERTIFICATE OF MERIT NO. 1995.

FIXED CONDENSER

The "Dubilier" condenser (Type PL-381 shown), submitted by the Dubilier Condenser & Radio Corp., 4377 Bronx Blvd., New York City, is of the paper type and intended to be used in "B" socket-power units using rectifiers of the Ray-



theon type. This block has a total capacity of 14 mf., and is provided with taps at 2, 2, 4, 4, 1, 1 mf., which represent the different capacities needed for the filter circuit. The continuous-operating D.C. voltage is rated at 400.

AWARDED THE RADIO NEWS LABORATORIES CERTIFICATE OF MERIT NO. 1996.

DIAL LIGHT

The "Mar-Co" dial light (No. 230 shown) submitted by the Martin-Opland Company, Providence, R. I., is a very efficient device for illuminating the scales of the dials and can be easily installed on any radio receiver. It is provided with



a lamp switch and a thin flat clamping spring, which slips between dial or housing and the panel. The device is held in the required position by pressure or clamped to the panel

with a screw and nut. The little bulb operates either from the "A" battery or from a separate dry cell of the "C" type.

AWARDED THE RADIO NEWS LABORATORIES CERTIFICATE OF MERIT NO. 1997.

VARIABLE CONDENSERS

The "Precision" variable condenser shown, submitted by Jackson Bros., 8 Poland St.-Oxford St., London, W. 1, England, is of the low-loss S.L.F. type. It has a maximum capacity of 473 mmf. (rated .0005 mf.), and a minimum of 15 mmf. This instrument is very neat in appearance and is well designed electrically and mechanically. A molded bakelite dial is supplied with it.

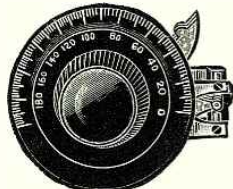

The "Precision" Condenser Vernier shown, in its main features identical in construction to the plain-type condenser described above. It differs only in that it is equipped with a vernier arrangement of the friction type, having a ratio of 39:1, and that there is a pigtail connection between the rotor and end plates. Both condensers are of the one-hole mounting type.



AWARDED THE RADIO NEWS LABORATORIES CERTIFICATE OF MERIT NO. 1998.

RESISTOR

The "Vitrohm" resistor (type 50-62 shown), submitted by the Ward Leonard Electric Co., Mount Vernon, N. Y., is designed to be used in an "A-B-C" power-supply unit, using the new Raytheon tube of 350-



400 milliampere output. This unit is formed of two separate resistor strips mounted on the same brackets. One of those strips has a resistance of 600 ohms and is intended for the plate-voltage supply; while the other, of 4,160 ohms, is intended for the "A" and "C" voltages. Both strips are tapped and connected in series. The first makes possible seven dif-

ferent plate voltages and the second three different grid-biasing voltages. The unit is compact and rigidly built.

AWARDED THE RADIO NEWS LABORATORIES CERTIFICATE OF MERIT NO. 2000.

BATTERY TESTER

The "Beede Test-A-Bar" shown, submitted by the Beede Instrument

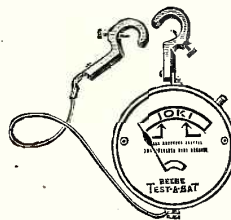

Co., Penacook, N. H., is of the plunger-type current indicator. By pressing a special button the circuit of the coil is closed, and the instrument operates. As the device is used only during a very short time it does no harm when a relatively heavy current (somewhat over four amperes) is passing through the coil. The operation is satisfactory and the indications are correct. The instrument is designed to be permanently attached to the "A" battery.

AWARDED THE RADIO NEWS LABORATORIES CERTIFICATE OF MERIT NO. 2001.

VARIABLE CONDENSER

The "Pilot Centraline Capacigrad" variable condenser shown, submitted by the Pilot Electric Manufacturing

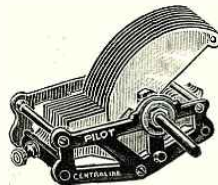

Company, Inc., 323 Berry Street, Brooklyn, New York, is of the low-loss, one-hole-mounting type. This seventeen-plate condenser has a minimum capacity of 12 mmf. The plates are so shaped that a very even distribution of the broadcast stations along the dial periphery is obtained. This instrument is neatly and efficiently built.

AWARDED THE RADIO NEWS LABORATORIES CERTIFICATE OF MERIT NO. 2002.

DIAL

The "Pilot" vernier dial ("De-Luxe Model shown"), submitted by the Pilot Electric Manufacturing Company, Inc., 323 Berry St., Brooklyn, N. Y., has a very neat molded bakelite shell and can be easily installed on any receiver. This tuning device is provided with two

calibrations, so that it may be adapted to either clockwise or counter-clockwise condensers. The vernier ratio is approximately 13 $\frac{1}{2}$:1.



AWARDED THE RADIO NEWS LABORATORIES CERTIFICATE OF MERIT NO. 2003.

VACUUM TUBE

The "Magnatron" tube (type DC 240 shown), submitted by the Con-



newey Electric Laboratories, 406 Jefferson St., Hoboken, N. J., is of the UX type. The amplification constant and the impedance are unusually high, a feature which makes this tube very suitable for use in resistance-coupled amplifiers or as a detector operating in connection with a resistance-coupled amplifier.

AWARDED THE RADIO NEWS LABORATORIES CERTIFICATE OF MERIT NO. 2004.

A.F. TRANSFORMER

The "Transfolina" transformer (type 116 shown), submitted by Societe Belge Radioelectrique, Brussels,



Belgium, has been found to have very good amplification characteristics, within the limits of the most used audio frequencies, and permits very fine reproduction of speech and music when used in a audio-amplification stage.

AWARDED THE RADIO NEWS LABORATORIES CERTIFICATE OF MERIT NO. 2005.

RESISTORS

The "Kroblak" fixed resistor shown, submitted by C. E. Mountford, 465-467 Greenwich St., New

York City, is of the wire-wound type. The resistance wire is wound on a porcelain tube, $\frac{3}{8}$ -inch in diameter, and is covered with black



enamel, which protects it from mechanical injury and corrosion. The submitted units had their measured resistance close to the rated values of 10,000 and 50,000 ohms.

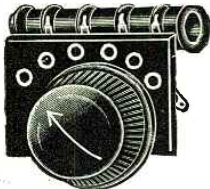

The tapped fixed resistor shown is similar in construction to the unit described above. It has a total resistance of approximately 33,000 ohms and is tapped every 6,500 ohms. The taps are connected to a built-in switch, which makes the unit very suitable for use in a "B" power unit.

AWARDED THE RADIO NEWS LABORATORIES CERTIFICATE OF MERIT NOS. 2006 and 2007.

TUNING ATTACHMENT

The "Station Separator" shown, submitted by the Klossner Radio Corporation, 1022 East 178th Street, New York City, is designed to overcome the crowding of broadcasting stations by increasing the selectivity of the average receiver using a cus-



tomary antenna. It consists of a coil, approximately 300 mhenries,

having its windings in the two grooves of a wooden form. The housing is of molded bakelite and provided with two binding posts and a knife switch, which, when closed, shorts the coil, thus eliminating it from the antenna circuit.

AWARDED THE RADIO NEWS LABORATORIES CERTIFICATE OF MERIT NO. 2008.

FIXED CONDENSER

The fixed condenser shown, submitted by John E. Fast & Co., 3982 Barry Ave., Chicago, Ill., is of the



paper type. It is very compact, enclosed in a sturdy metal shell, and can be used efficiently as a by-pass condenser. It is available in different capacities.

AWARDED THE RADIO NEWS LABORATORIES CERTIFICATE OF MERIT NO. 2010.

VACUUM TUBE

The "Vogue Nonpareil" radio tube



(type 201A shown), submitted by the Allan Manufacturing Co., Arlington, N. J., is of the UX type and has the characteristics of a good 201A-type tube. It operates very well either as amplifier or detector.

AWARDED THE RADIO NEWS LABORATORIES CERTIFICATE OF MERIT NO. 2011.

FILAMENT RESISTOR

The semi-adjustable resistance unit shown, submitted by the BCM-Deckorem Radio Products, London, England, is designed for baseboard mounting in order to eliminate panel control. It is adjustable over its whole range to insure best working conditions for the vacuum tube. The element, which is made of resistance

wire wound on a bakelite block $2\frac{1}{2} \times \frac{1}{2}$ -inch, can be easily removed and exchanged. These removable cartridges are available in different resistance values.

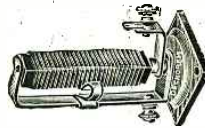

AWARDED THE RADIO NEWS LABORATORIES CERTIFICATE OF MERIT NO. 2014.

HIGH RESISTOR

The "Aerovox" resistance shown, submitted by the Aerovox Wireless Corp., 70 Washington St., Brook-



lyn, N. Y., is of extremely fine resistance wire, wound on a porcelain tube and covered with a protecting vitreous enamel. As very good cooling is insured, the unit can stand a relatively high load. It is designed to be used mostly in "B" power-supply units, and is available in different sizes and resistance values.

AWARDED THE RADIO NEWS LABORATORIES CERTIFICATE OF MERIT NO. 2015.

GROUND ANTENNA

The "Inducto Radio Ground" shown, submitted by the Radio Devices Co., Bethel, Berks County, Pa., consists of rubber-covered fixture wire wound in one layer on a $\frac{3}{8}$ -inch iron rod, 13 inches long. The coil so formed is covered with



several layers of thin cardboard. The iron rod is insulated from the winding, one end of which is open while the other is connected to a binding post to which the ground lead of the receiver is attached. This device has been found to operate satisfactorily when shoved a few feet into the damp ground.

AWARDED THE RADIO NEWS LABORATORIES CERTIFICATE OF MERIT NO. 2016.

REPRODUCER

The "Musicoila" loud speaker shown, submitted by C. A. Vanderwell and Co., Ltd., Wargle Way, Acton, London W. 3, England, is of the cone type. The edges of the paper diaphragm are tightened between two metallic rings. The driving rod is attached to the center of an iron vibrating strip $1/16$ -inch

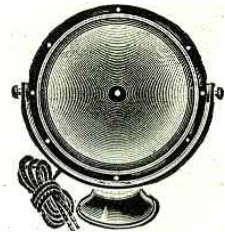

thick, in front of the electro-magnet. The cone with the unit is suspended in such a way that it can be given different inclinations with regard to the stand. This instrument has been found to afford very fine reproduction with regard to quality and volume.

AWARDED THE RADIO NEWS LABORATORIES CERTIFICATE OF MERIT NO. 2017.

VACUUM TUBE

The detector tube (type 150D shown), submitted by the Magnavox Co., 2726 East 14th St., Oakland,



Calif., is of the duplex-grid type and similar in construction to other Magnavox tubes. It is designed especially to afford very fine quality of reproduction and good volume on local stations, although it operates successfully on distance too.

AWARDED THE RADIO NEWS LABORATORIES CERTIFICATE OF MERIT NO. 2018.

SHORT-WAVE EXPERIMENTS WITH ULTRA-VIOLET RAYS

By ENGINEER A. RIECHERS, (Coburg, Germany)

ONE of the earliest experiments conducted with ultra-violet radiation, in the nature of communication, was the modulation of a beam of these rays which was directed at a light-sensitive cell. The voice of a speaker at the transmitting end could be detected by means of a head-set connected across the cell at the receiver. This experiment can be performed also with a beam of ordinary or infra-red rays.

The latest experiments with ultra-violet rays in the communication field have been made by the writer (in Germany) utilizing a beam of these invisible rays as a receiving antenna for short-wave reception. It is a well-known fact that electrical oscillations can be set up in gaseous, as well as in metallic circuits; but in these, conditions are widely different. In a gaseous conductor (which air is, especially when ultra-violet rays are present) the high resistance and the characteristic absorption of the atmosphere must be taken into consideration. The experiments heretofore conducted, using a beam of ultra-violet rays as a receiving antenna, have led to no very definite results, because of the expense of maintaining such an antenna and also the complexity of the connections to the receiving set.

The experiments in using an ultra-violet beam for a receiving antenna are rather difficult, and many observations must be taken to arrive at a conclusion which excludes a

disturbing factor, the influence of the ultra-violet rays themselves; as these come into the calculations because they are a conductor

for short waves and capable of introducing oscillations. This is only one of many errors that might creep into the results and throw them out. It is well known that short waves, because of their high frequency, require but a very short antenna and they are sometimes picked up by a receiver without either aerial or ground connection. In other words, it is extremely difficult to determine whether impulses are being received solely through the medium of the antenna. Even though the set be shielded, there are in the neighborhood of the set wires connecting the batteries, or metal objects which may have some effect upon the circuit.

For the generation of the ultra-violet beam, which must be a powerful one, a special projector, or searchlight with an arc lamp and a concave reflector, is employed. In order to obtain a beam whose rays are not diverging, but parallel, the arc is located at the exact focus of the reflector. Directly in front of the lamp is a condensing lens made of "Uvioglas," which is filled with a blue liquid that allows only the ultra rays to pass. This lens must not be of ordinary glass, as that will effectively stop the rays which are here used. Before the lens just mentioned there is placed a wire-net-work or grid which is connected to the antenna binding post of the receiver by a short lead. The receiver is carefully insulated from the

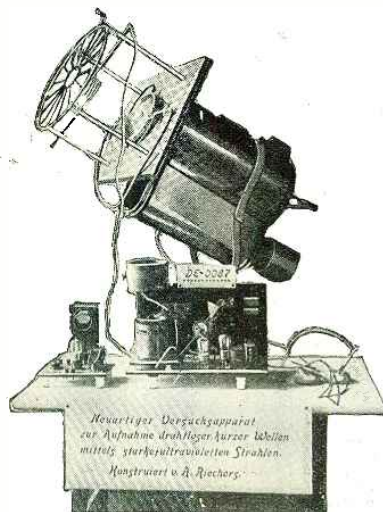

Herr Riecher's receiver with the searchlight whose beam is his aerial.

(Continued on page 74)

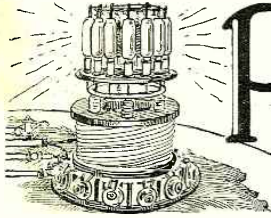

Progress in Radio

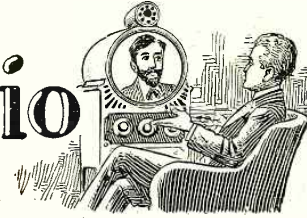

NEW GERMAN RELAY USE OF NEON LAMP

SINCE the very beginning of the telegraph industry, the need for a suitable relay has always been of paramount importance. With the advent of radio telegraphy, the demand for such an instrument has become, if anything, still greater, especially for the purpose of reception by automatic recording devices.

For this requirement, briefly put, is some device which can be "triggered" by the extremely weak electrical impulses set up in a receiving aerial by the incoming signals; thereby causing them to control the relatively large amounts of electrical power which are required to operate the recording instruments.

From time to time various devices have made their appearance, until, with the development of the modern thermionic tube, radiotelegraph engineers were given a device whose sensitivity far surpassed all others. Research work is still carried on, however, and the latest development in relay devices comes from Germany, where, at a recent meeting of the Association of German Scientists and Doctors at Düsseldorf, Doctors Richter and Geffken, of Leipzig, described a new type of relay which is remarkable for its extreme sensitivity in the reception of radio signals.

The principle employed is not new, for the relay makes use of a well-known property of the neon lamp, whereby a certain minimum threshold value of the applied voltage is necessary in order to start the discharge.

DETAILS OF THE RELAY

A sketch of the device is given in Fig. 1. It consists of a glass tube, or bulb, filled with neon gas, and enclosing three electrodes in the form of rectangular plates, all arranged parallel to one another. The two outer electrodes, which serve as anode and cathode, are connected to the screw-socket base. Mounted between the anode and cathode is the third, which acts as the intermediate "igniting" electrode, and this is connected to the terminal at the top of the tube.

The principle of its action is illustrated in Fig. 2, where P is the anode, K the cathode, and Z the "igniting" electrode. Neglecting the igniting electrode for a moment, a glow discharge will occur between the anode and cathode when a certain exactly-definite potential is applied between them.

At a slightly lower potential this glow discharge will not start; but it can be made to do so if a certain potential is applied to the intermediate electrode Z. Quantitative measurement shows that there are two dif-

ferent limiting values for the potential which must be applied to the intermediate electrode before the discharge commences.

The discharge current through the tube reaches a maximum value of 30 to 50 milliamperes, depending upon the size of the electrodes; but the current necessary to charge the electrode Z can be infinitesimally small. It has been determined that, on an

W1, while another resistance, W2, is connected in the lead to the igniting electrode of the glow discharge relay. A condenser C is connected between the igniting electrode and the cathode.

The resistances must be chosen so that when there are no radio signals arriving, the tube does not glow, but at the instant when weak signals arrive the adjustment must be such that the igniting electrode becomes sufficiently charged to cause response.

The procedure is that the incoming signals cause the grid of the thermionic tube to become negatively charged, whereby the plate current of the tube is reduced. The potential drop across the resistance W1 is also reduced, while the drop across the thermionic tube is increased. The potential of the igniting electrode is thereby correspondingly changed, so that the glow discharge through the neon tube commences. In this manner an extremely simple recording receiver is obtained.

Using the arrangement illustrated in Fig. 3, and employing only one thermionic tube, it has been found possible to record time signals from Nauen (Germany) at Leipzig (a distance of about 300 miles) with an accuracy, as established by the Leipzig observatory, of one hundredth of a second.

There would appear to be a very useful future ahead for this new relay, for the number of ways in which it could be applied to radio reception is almost unlimited. Perhaps its greatest sphere of usefulness may be in connection with the remote control of ships, airplanes, torpedoes, etc., by means of radio impulses, or it might be used as a simple call-device.—A. Dinsdale.

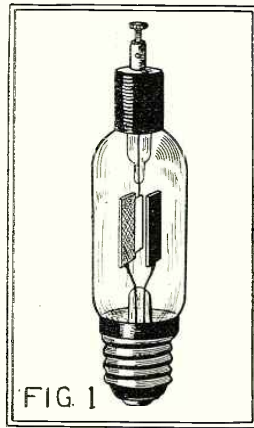

FIG. 1
A new ultra-sensitive German relay tube, which is filled with neon gas.

average, a current of 10^{-10} (one ten-billionth) ampere is amply sufficient for this purpose.

Thus, by means of this glow discharge, such minute currents can be made to actuate relatively heavy mechanical relays, for which a current of 10 milliamperes is quite sufficient.

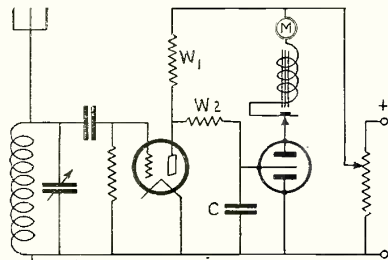

FIG. 3

A radio circuit in which is incorporated the neon relay tube for automatic recording.

APPLICATION TO WIRELESS RECEIVING CIRCUITS

The discharge, once started by the trigger action of the igniting electrode, does not extinguish itself again. In this respect it is similar to a coherer. The relay can be made self-restoring, however, by the interposition of an interrupter somewhere in the anode circuit.

In Fig. 3 is shown a radio receiving circuit which illustrates how the relay can be adapted for use with an automatic recording device.

In the plate-circuit of the ordinary thermionic tube there is connected a resistance

CONSTANT REGENERATION

A RECEIVER employing constant regeneration control is described in a British patent by M. A. Robinson. The idea of the invention is to include a resistance in series with the aerial lead and suitably arrange the circuit, so that regeneration is fairly constant over the whole condenser range. In the illustration the receiver comprises an ordinary tuned input circuit, consisting of an inductance L1 tuned by a variable condenser C1, connected between the grid and filament of the tube, the usual grid condenser being provided for detection purposes. The plate circuit contains a tickler coil L2, which is coupled in fixed relationship to the inductance L1. The aerial is not connected directly to the end

(Continued on page 75)

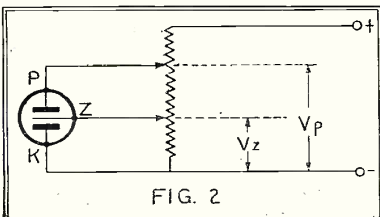
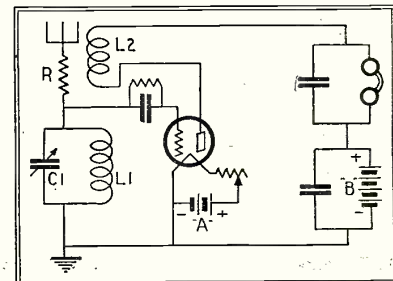

FIG. 2

P is the anode; K, the cathode and Z, the "igniting" element of the new neon-tube relay.



A British receiving circuit for which the claim is made that constant regeneration is obtained.



Conducted by Joseph Goldstein

THIS Department is conducted for the benefit of our Radio Experimenters. We shall be glad to answer here questions for the benefit of all, but we can publish only such matter as is of sufficient interest to all.

1. This Department cannot answer more than three questions for each correspondent. Please make these questions brief.
2. Only one side of the sheet should be written upon; all matter should be typewritten or else written in ink. No attention paid to penciled matter.
3. Sketches, diagrams, etc., must be on separate sheets. This Department does not answer questions by mail free of charge.
4. Our Editors will be glad to answer any letter, at the rate of 25c. for each question. If, however, questions entail considerable research work, intricate calculations, patent research, etc., a special charge will be made. Before we answer such questions, correspondents will be informed as to the price charge.

SHORT-WAVE TRANSMISSION

(Q. 2218) Mr. L. Donald, Sacramento, Calif., asks:

Q. 1. I am contemplating the construction of a short-wave receiver of the plug-in type, to cover the wavelengths from 20 to 100 meters. Will you please inform me as to whether there are any broadcasting stations operating on these wavelengths, and also what wavelengths are used by amateur transmitting stations?

A. 1. According to our latest available information, there are only four such broadcast stations operating regularly on these short waves. They are KDKA, at East Pittsburgh, Pa., which operates almost nightly on wavelengths of 63 and 14 meters; Station WGY (2XAD and 2XAF) at Schenectady, N. Y., which transmits on 22.6, 26.2 and 32.8 meters with a rebroadcast of the regular transmission of WGY on 380 meters. Both of these stations come through with tremendous volume on these waves, being considerably louder than on their normal wavelength. WLW, Cincinnati, now broadcasts all its programs on 52.02 meters, and WABC, New York, on 64 meters.

The transmissions of KDKA and WGY have been heard repeatedly in Australia and South Africa, a fact which demonstrates the tremendous carrying power of high frequencies.

The wavelengths now most used by amateur transmitting stations are the so-called 40- and 80-meter bands. The former, to be exact, includes the wavelengths between 37.5 meters and 42.5 meters; while the higher band, used principally for phone work, includes those from 75 to 85 meters.

MAKESHIFT ANTENNA

(Q. 2219) Mr. Clarence Seid, Brooklyn, N. Y., asks:

Q. 1. Will you kindly describe in your columns a makeshift method to be employed when the regular aerial is down?

A. 1. As an emergency measure, when the regular aerial is "down," connect the input circuit of the receiver as shown in the accompanying diagram; it may be found satisfactory for both local and distant reception.

In effect, the aerial is replaced with the ground-condenser combination shown. The ground, G1, should be one other than the regular ground to the receiver. This combination will often be found very satisfactory in apartment houses where G is the water pipe and G1 a radiator. The condenser, C, should be as large as possible. However, the lower this capacity, the less the pickup through this means and the greater the selectivity.

POWER-UNIT REGULATION

(Q. 2220) Mr. D. Robert, Sea Cliff, L. I., asks: Q. 1. I am using a superheterodyne with a "B" power unit, with the 45-volt tap used to supply the detectors and intermediate stages. I do not obtain satisfactory reception and upon measuring the voltage across this tap I find it registers only 28 volts. Could you suggest some way, whereby I could maintain the voltage of this tap at 45?

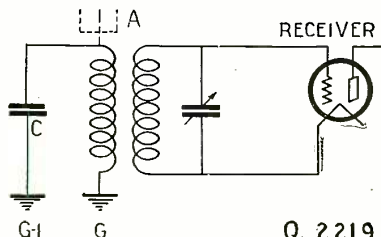

Q. 2219 This diagram illustrates the use of a separate ground connection as a temporary substitute for the aerial.

A. 1. Very often the drain from the 45-volt tap on a "B" power unit is in excess of that provided for in the design of the device, with the result that the voltage is below normal. This is particularly true with superheterodyne receivers. In these instances five or six tubes are supplied from one tap, resulting in an excessive drain.

By connecting a variable resistor between the 45- and 90-volt taps, the voltage at the 45-volt tap can be raised to the desired figure. The position of this resistor is shown in Fig. Q.2220. Its selection is governed by the current-carrying capacity of the unit. It should at all times be capable of carrying at least twice or three times the actual current flow.

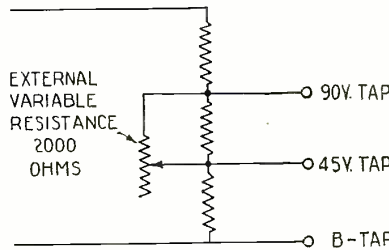

Q. 2220

Showing the use of a separate resistor to stabilize the output from a "B"-power unit.

WAVELENGTH CALCULATION FORMULAS

(Q. 2221) Mr. A. Cadot, Ossining, N. Y., asks: Q. 1. Could you furnish me with some simple formulas for the calculation of the wavelength of a coil and condenser combination, when the capacity and inductance are known, and the approximate inductance of a toroid coil?

A. 1. The following are several formulae from which the wavelength or frequency of a coil and condenser circuit can be determined with fair accuracy:

$$\text{Wavelength } (\lambda) = 1884 \sqrt{LC}$$

To find the frequency (in kilocycles) of a circuit consisting of a coil and condenser use the following formula:

$$\text{Frequency } (f) = \frac{159.2}{\sqrt{LC}}$$

In both cases L is the inductance of the coil expressed in microhenries, and "C" the capacity of the condenser in microfarads.

To find roughly the inductance of a coil of the toroid type, the following formula is employed:

$$L = .01257 N^2 (R - \sqrt{R^2 - A^2})$$

In this instance R is the radius of the toroid from the center of the doughnut to the center of winding, A is the radius of the turns of the winding, and N is the number of turns.

BATTERYLESS LABORATORY OSCILLATOR

(Q. 2222) Mr. J. Walthier, Redlands, Calif., asks:

Q. 1. I would like to construct an oscillator for use in my experiments. I have heard that such an apparatus can be constructed without using "A," "B" or "C" batteries, using the line supply as a source of power. Could you give me a diagram and any other information relative to this device?

A. 1. The suggestion of an oscillator hook-up on a power line without "A," "B" or "C" batteries is one which will appeal to all experimenters. The added advantage of being adaptable to either A.C. or D.C. circuits makes it universal in character. Of course, A.C. has advantages, and in this case the tube is supposed to do whatever rectifying action may be necessary. With D.C. the author of the circuit relies on the commutator ripple found on any D.C. line.

The accompanying diagram (Fig. Q.2222) is self-explanatory, except that the connections of plate return and grid return are to opposite sides of the filament, on the theory that in this way the grid will be minus when the plate is positive. The resistor can be anything, but a simple 25-watt lamp is suggested where the line voltage is 110. The frequencies through which the oscillator will work are determined by the size of coils and condensers, as in any radio set. Plate and grid coils are of equal size. Coupling is kept close, by winding both coils on the same tube.

"C" SOCKET-POWER UNIT

(Q. 2223) Mr. L. Miller, Amundale, N. J., asks:

Q. 1. I have constructed a power unit, using a resistor and condenser to obtain the necessary "C" bias. However, I have not been obtaining very satisfactory results, and I think the trouble lies in the method of obtaining the "C" voltage. Is the resistor and condenser method of obtaining negative bias satisfactory, or should the ordinary type of "C" battery be used instead?

A. 1. A series of experiments carried out by Mr. R. P. Clarkson upon "B" power units, which also supplied the "C" bias necessary for the power tube in the audio amplifier, has brought the conclusion that in altogether too many instances trouble encountered with "B" supply devices can be attributed to the "C"-bias resistor and condenser.

"The utilization of the 'C'-bias resistor and condenser in a 'B' or 'C' unit was found to be the cause for 'motor boating' with some power-transformer-coupled audio amplifiers." Mr. Clarkson

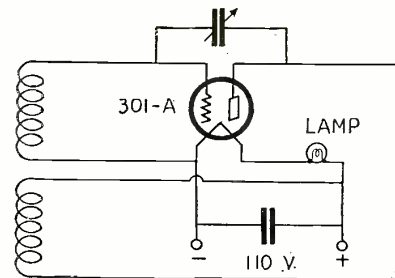

Q. 2222

An experimental oscillator utilizing the power line for its "A" and "B" supply.

states, in an article of recent date in the *New York Sun*. "With the normal 'C' arrangement, consisting of a resistor of approximately 1,100 ohms to supply the bias for a 171-type power tube, and a by-pass condenser of 1-mf. for this resistance, there was pronounced 'motor boating' with a transformer-coupled audio amplifier, when the amplification was adjusted to maximum. But when the 'C'-bias arrangement was removed from the unit and the 'C'-bias obtained from a battery, the trouble was immediately removed. Now, with the original 'C' biasing arrangement in the circuit, it was found that the use of a higher value of by-pass capacity for the 'C'-bias resistance was necessary if the

'motor boating' was to be removed. To all intents the by-pass condenser of 1-mf. was insufficient.

"The value of the 'C'-bias by-pass capacity brings into discussion the item of cost. Judging from the experiments, a capacity of at least 4-mf. is necessary across the 'C' biasing resistor. The cost of such a capacity and the proper resistor is equal to, if not greater than that of a 'B' battery unit utilized as a 'C' block.

"Constructors of 'B' power units would do well to heed the following advice: Build your 'B' supply and omit the 'C' biasing resistor. Utilize a separate 'C' battery for the purpose. This can be carried out with perfect satisfaction whether D.C. or A.C. is supplied to the filaments. Experimental work carried out over a period of six months seems to show that the 'C'-bias arrangement in socket-power units is a cause for all sorts of noises in the receiver as heard in the speaker.

"From an angle of economy and efficiency a separate battery for 'C'-bias is more satisfactory. This is particularly true when the average 'B' supply unit is applied to the average radio receiver. Excessive hum in the output circuit of the receiver was found to be due to the 'C'-bias arrangement. The removal of the 'C'-bias resistor and the use of a separate 'C' battery in several cases reduced the hum to almost inaudibility.

"The statements in the preceding paragraphs should not be construed as signifying that all 'C' battery arrangements in use at present are deficient in operation. Many are satisfactory, as are many supply units; but it is also true that many are unsatisfactory. For the constructor the advice is to use a battery for the source of 'C' voltage."

These conclusions may be endorsed, unless the constructor is working with very high-grade material, and a plan and specifications which have been worked out satisfactorily and approved by radio engineers.

A QUALITY SUPERHETERODYNE

(Q. 2224) Mr. Geo. Taber, Cornwall, N. Y., asks:

Q. 1. I am desirous of constructing a superheterodyne combining the latest type of R.F. amplification with an audio amplifier designed for quality reproduction. Could you supply me with complete information and schematic wiring diagram of such a receiver, employing preferably 9 tubes, with push-pull amplification in the last stage?

A. 1. As we all know, a superheterodyne is considered the most sensitive set yet developed, and, if good results are to be obtained, it must be so designed that it is not encumbered with internal parasitic noises. Then, again, a set of this type must possess unusual selectivity to overcome the terrific congestion on the present-day broadcast waveband. Another drawback, due to the exceptional sensitivity of a good superheterodyne, is that the input energy of the audio amplifier is excessive when receiving local stations. Nearly all audio amplifiers, and even the second detectors in these sets, are incapable of holding such a great amount of energy without serious distortion. These are but the few of the problems which have come up in relation to superheterodyne receivers.

The superheterodyne we are about to describe was designed by Mr. A. E. Poté and originally described by him in the *New York Herald Tribune*. In this receiver an entirely new form of I.F. amplification is employed. Reference to the schematic diagram will show that the I.F. amplifier is of the choke coil-impedance-coupled type, very similar to an ordinary impedance-coupled audio amplifier, R.F. chokes having a value of 500 millihenries are used in the plate circuits of the three I.F. tubes V2, V3 and V4 and the first detector tube V1. Standard-type resistors R1, R2 and R3 are used in the grid circuits.

This particular I.F. amplifier is not peaked at any one frequency; in other words, it is perfectly impartial to all frequencies and will amplify one equally as well as another. To put it in another way, this type of amplifier has no selectivity what-

soever. It would seem that we are losing efficiency and selectivity here; however, here is where the band-pass filter or filter transformer comes into play. This filter, indicated as L5 in the diagram, is tuned to 45 kc. and allows a 10,000-cycle band of frequencies to pass. This includes just the normal audio frequency band which we desire to get through and no more. The filter is connected in the usual manner in the input circuit of the second detector tube V5.

Referring to the schematic wiring diagram (Fig. Q. 2224), the antenna circuit is tuned to a signal and the oscillator circuit adjusted to produce a beat-frequency of 45 kc. This frequency is passed through the first detector tube V1 and amplified in the I.F. amplifier; but this will amplify any other intermediate frequency just about as well as 45 kc. As mentioned above, there is no selectivity whatsoever present in these stages. The band-pass filter now separates the 45 kc. from all the rest of the frequencies and lets it pass through, with 10,000 cycles on each side of it, to take care of speech and music. In this manner all of the selectivity is gained by the use of the band-pass filter, without any of the usual troubles experienced when employing tuned or untuned transformers which are hard to stabilize.

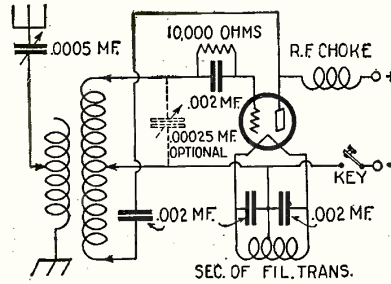

Q. 2225

Diagram of an extremely efficient short-wave transmitter employing the Hartley circuit.

No potentiometer or other form of oscillation control is used for stabilizing the I.F. amplifier; nothing of this sort is necessary, since the tubes are operated at maximum efficiency at all times and work with a negative bias on the grids. As stated before, the band-pass filter is tuned to a frequency of 45 kc. This was found to be about the best point of operation, but it is obvious that, since the choke-coupled amplifier itself is not tuned to any definite intermediate frequency and amplifies one band as well as the next, the band-pass filter can be tuned to some other frequency if it is found desirable. This can easily be done by altering the values of the fixed condensers C9 and C10, which in this particular case are .001-mf.

The A.F. circuit is rather unique. This superheterodyne is so sensitive that it was found necessary to employ plate rectification in the second detector tube V5 in order to eliminate distortion due to overloading. Consequently the grid leak and condenser were dispensed with and the grid return of this tube run to a 'C' battery having a negative value of 4½ volts. Incidentally, the same 'C' battery is used to bias the grids of the I.F. tubes. The audio amplifier consists of one stage of transformer coupling and a push-pull stage using two power tubes of the 171 type. The reason for this arrangement is the fact that, when not more than one stage of transformer amplification is used, distortion is practically eliminated without decreasing the volume perceptibly. Semi-power tubes of the 112 type could be used

in the push-pull stage of this receiver, but they are not large enough electrically to handle the load. The 171 tubes, however, are perfectly satisfactory; the two of them used in this manner are equal to a power tube of the 210 type and will require only 180 volts of "B" battery. It will be noted from the diagram that a push-pull impedance T2 is used at the output, rather than another push-pull transformer. This is by far the best method; this is the first time it has been employed in an audio amplifier. It takes the place of the usual type of output impedance or output filter and, in one sense, it is a cheaper arrangement, as no blocking condenser is required.

All the tube filaments are controlled by a single power rheostat R5, as there is no necessity for critical filament adjustments. The volume is controlled by a 500,000-ohm variable resistor R4 connected across the grid resistor of the first I.F. tube V2. Since the choke-coil I.F. amplifier is capable of amplifying high frequencies, an R.F. choke L2 having a value of 85 millihenries is connected in the plate circuit of the first tube to keep the R.F. currents out of the amplifier circuits.

A choke of 85 millihenries is also connected in the oscillator "B" battery lead, to keep the oscillator currents out of the common battery circuit. Two more chokes L4 of 500 millihenries are used in the common plate and grid leads of the intermediate amplifier to keep any of the I.F. currents from leaking into the battery circuit; also two A.F. chokes, L7 and L8, to keep the A.F. currents where they belong.

The following is the list of parts necessary for the construction of this receiver:

- 1 antenna coupler, L;
- 1 double-wound oscillator coupler;
- 3 I.F. impedances, L3;
- 2 chokes, 500-millihenry, L4;
- 2 chokes, 85-millihenry, L2;
- 1 band-pass filter, 45 kc., L5;
- 1 R.F. choke, 250-millihenry, L6;
- 1 A.F. choke, 30-henry, L7;
- 1 A.F. choke, 3.5-henry, L8;
- 2 variable condensers, .0005-mf., C, C1;
- 1 neutralizing condenser, 45-mmf., C2;
- 2 by-pass condensers, .001-mf., C3, C12;
- 4 fixed condensers, .002-mf., C6, C7, C8, C11;
- 2 fixed condensers, .001-mf., C9, C10;
- 1 by-pass condenser, 1-mf., C13;
- 1 by-pass condenser, 4-mf., C14;
- 1 by-pass condenser, 2-mf., C15;
- 3 resistors with mountings, .05-megohm, R1, R2, R3;
- 1 volume control, 500,000-ohm, R4;
- 1 power rheostat, 2-ohm, R5;
- 1 audio transformer, T;
- 1 push-pull transformer, T1;
- 1 push-pull impedance, T2;
- 1 voltmeter, 0-8 volts;
- 1 switch, D.P.S.T.;
- 7 vacuum tubes, type 201-A, V, V1, V2, V3, V4, V5, V6;
- 2 vacuum tubes type 171, V7, V8;
- 9 sockets, UX;
- 1 seven-wire battery cable and plug;
- 2 tip jacks for loud-speaker connection;
- 2 binding posts (antenna and ground);
- 2 vernier dials;
- 1 bakelite panel, 8x24;
- 1 sub-base panel, 11x23;
- 2 mounting brackets;
- 1 roll of flexible hook-up wire.

A 40-METER TRANSMITTER

(Q. 2225) Mr. K. Boyd, Schenectady, N. Y., asks:

Q. 1. Please publish the circuit diagram of a low-power short-wave transmitter employing the (Continued on page 72)

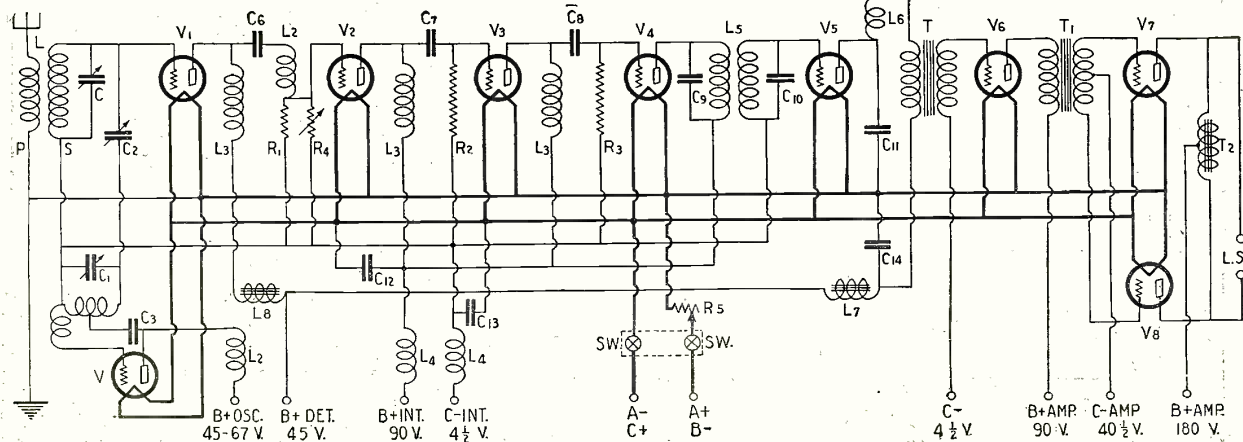

Q. 2224

Circuit of an improved superheterodyne which employs impedance-coupled intermediate-frequency amplifiers and a push-pull audio amplifier.

LEUTZ

UNIVERSAL TRANSOCEANIC

9 TUBES

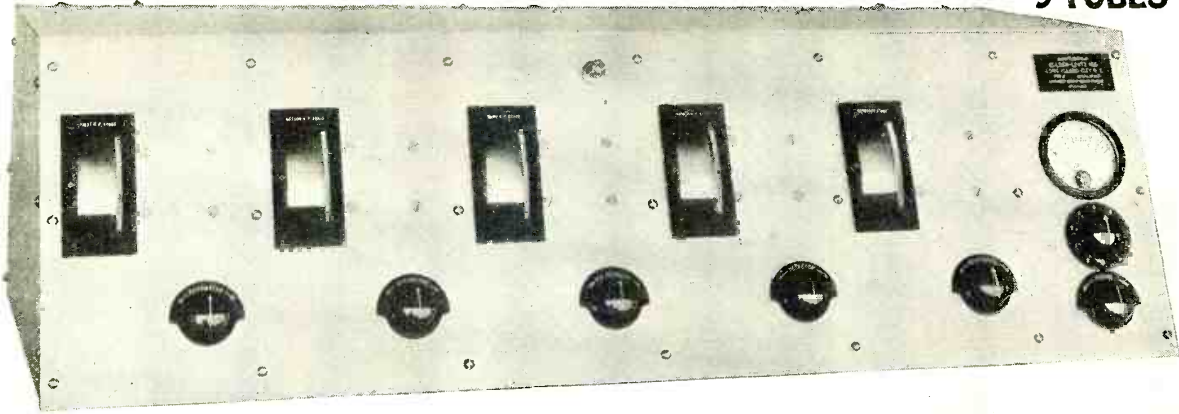

TRUE SELECTIVE POWERFUL

NEVER before has any radio ever provided at so low a price, so many QUALITIES and exclusive features. Modern to the minute in design, offering True distinction in appearance, built of fine materials, master workmanship,—the “UNIVERSAL TRANSOCEANIC” is the outstanding triumph of the most favorably known builders of powerful radio receivers.

Write For Our New Literature Today.

C. R. LEUTZ, Inc.

Sixth and Washington Aves., Long Island City, N. Y.

NOW

\$150

DIRECT

FROM OUR FACTORY

TO YOU

QUALITY AT LOW COST

Thousands Use These Ingenious TRANSMITTER UNITS

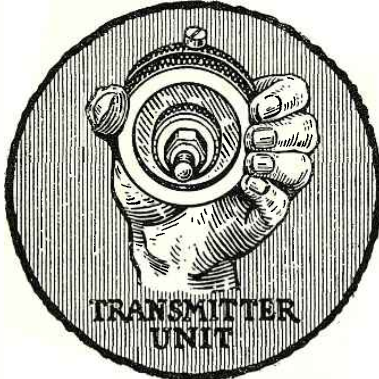

Here's a marvel of engineering design—a practical miniature transmitter, used by thousands of radio fans and experimenters for amplification purposes. It is a most novel unit, having hundreds of uses. Every amateur should have two or three of these amplifiers in his laboratory.

A FEW USES FOR THESE UNITS

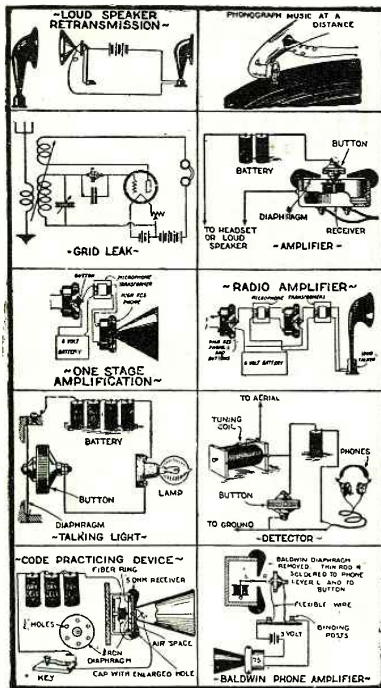

With each unit is mailed an eight-page instruction pamphlet containing suggestions for innumerable uses. Our supply is limited; avoid disappointment by ordering today. The coupon below is for your special convenience.

SPECIALY PRICED AT . . . 95c
(or Two for \$1.75) per unit

THE PRESS GUILD,
16-R East 30th St., New York, N. Y.
Enclosed find 95c/\$1.75 for which send me postpaid one/two amplifier units as advertised.
Name
Address
City, State

The Acme D-Coil Receiver

(Continued from page 40)

may be used; the "B" voltage fed to the post marked "B+ R.F." in any case need not exceed 90 volts. The detector may be another 201A type or a special detector; the voltage to the "B+ Det." post should conform to the tube manufacturer's recom-

mendations in this regard. The usual audio amplifier tubes (201A type for V4 and V5 and 112 or 171 for V6) should be selected. From 135 to 180 volts should then be applied to the "B+ Amp." binding post. The corresponding "C" voltages (listed on the boxes in which the selected tubes come packed) should be applied to the "C" posts. Nine volts for the "C" post between the "B+ Det." and "B+ Amp." posts on the schematic hook-up (the third post from the right in the picture diagram) will usually be found enough for the tubes in the V4 and V5 sockets.

SYMBOL	Quantity	NAME OF PART	REMARKS	MANUFACTURER *
L-C	1	Tuning Unit	Special "D" coil and condenser combined	1
L1	1	R. F. Transformer	Special untuned type	1
L2	1	R. F. Transformer	Special untuned type	1
C1	1	Variable condenser	.0005 mf. SLV type (tunes "D" coil)	1 4, 15, 40, 43, 44, 45, 46
C2	1	Fixed condenser	1 mf. By-pass	2 2, 8, 9, 10, 11, 18, 21, 24
C3	1	Grid condenser	.00025 mf. With grid leak clips	2 3, 8, 9, 10, 11, 18, 21, 24
C4	1	Fixed condenser	.02 mf. With double resistor mounting	2 9
C5	1	Fixed condenser	.0004 mf. By-pass in R.F. circuit	2 3, 8, 9, 10, 11, 18, 21, 24
C6	1	Fixed condenser	.002 mf. By-pass in det. circuit	2 3, 8, 9, 10, 11, 18, 21, 24
R	1	Fixed resistor	0.8 ohm fil. res. for 5 tubes	11 9, 12, 47
R1	1	Rheo. potentiometer	30-2000 ohms. Two combined in one unit	1 44
R2	1	Rheostat	12 ohms for last A.F. tube	4 5, 8, 11, 12, 13, 17, 19, 22, 44
R3	1	Grid leak	1 megohm	5 2, 3, 8, 9, 10, 41, 44
R4	1	Resistor	.15 megohm. Plate resistor	5 2, 3, 8, 9, 10, 41, 44
R5	1	Resistor	.5 megohm. Grid resistor	5 2, 3, 8, 9, 10, 41, 44
T	1	A.F. transformer		1 4, 14, 15, 20, 23, 43
I1	1	Impedance		1
SW	1	Filament switch		27 5, 6, 8, 11, 12, 13, 48
	7	Sockets	UX type, non-microphonic	6 4, 7, 15, 17, 40, 42, 43, 44
	11	Binding posts		7 4, 16, 44
	1	Binding post strip	2 X 3/4 X 3/16 inches	1 25, 27, 28
	1	Binding post strip	10 X 3/4 X 3/16 inches	1 25, 27, 28, 44
	3	B P brackets		1
	1	Panel	7 X 26 X 1/8 inches	1 23, 26, 27, 28
	2	Sub-base	8 X 25 X 1/2 inches Wood	
	1	Loop aerial	For .0005 mf. condenser	1 29, 30, 31
		Hook-up wire		32 33, 34
	5	Tubes	5 volt 1/4 ampere. Standard	35 35, 37, 38, 39
	1	Tube	5 volt 1/4 ampere. Special detector	35 36, 37
	1	Tube	5 volt 1/2 ampere. Power or semi-power	35 36, 37, 39

NUMBERS IN LAST COLUMN REFER TO CODE NUMBERS BELOW.

1 Acme Apparatus Company	2 Dubilier Condenser Corp.	3 Tobe Deutschmann Company
4 General Radio Co.	5 Allen Bradley Co.	6 Benjamin Electric Co.
7 H. H. Eby Mfg. Co.	8 Electrad, Inc.	9 Aerovox Wireless Corp.
10 Polymet Mfg. Corp.	11 Carter Radio Co.	12 Tuxley Mfg. Co.
13 H. H. Frost, Inc.	14 Samsom Electric Co.	15 Silver-Marshall, Inc.
16 X-L Radio Labs.	17 Outler Hammer Mfg. Co.	18 Sanganio Electric Co.
19 Central Radio Labs.	20 American Trans. Co. (Amertren)	21 Wireles Spec. App. Co. (Feredon)
22 George H. Walker Co. (Victoreen)	23 Thorderson Elec. Mfg. Co.	24 Potter Mfg. Co.
25 Formica Insulation Co.	26 The Liggett Corporation	27 American Hard Rubber Co. (Radion)
28 Insulating Co. of America (Inalins)	29 Bodine Electric Co.	30 Duro Metal Products Co.
31 Radio Appliance Co.	32 Belden Wire Co.	33 Cornish Wire Co.
34 Acme Wire Co.	35 C. E. Mfg. Co. (Ceco)	36 Radio Corp. of America
37 E. T. Cunningham, Inc.	38 The Van Horne Co.	39 The Mamavox Co.
40 Gray & Danielson (Romler)	41 International Resistance Co.	42 AirKee Prod. Co.
43 A.L. American Radio Corp.	44 Ameco Products, Inc.	45 National Co.
46 Hammerlund Mfg. Co.	47 Lansbein Kaufman Co. (Elkay)	48 Brent Electric Co.
	49	50
		51

* THE FIGURES IN THE FIRST COLUMN OF MANUFACTURERS INDICATE THE MAKERS OF THE PARTS USED IN THE ORIGINAL EQUIPMENT DESCRIBED HERE.

If you use alternate parts instead of those listed in the first column of manufacturers, be careful to allow for any possible difference in size from those originally used in laying out and drilling the panel and sub-base.

An 18 to 1500-Meter Receiver

(Continued from page 37.)

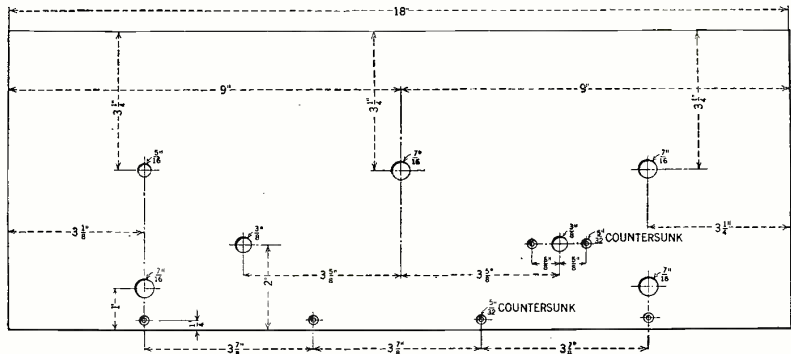

Drilling details for the panel of the 18-1500-meter receiver as shown on page 34.

At the
R. M. A. Trade Show
Stevens Hotel, Chicago
JUNE 13th to 17th

**DON'T FAIL to see
the exhibit of Balkite,
the leader in the radio
power unit field.**

FANSTEEL PRODUCTS CO., Inc., North Chicago, Illinois



Balkite
Radio Power Units

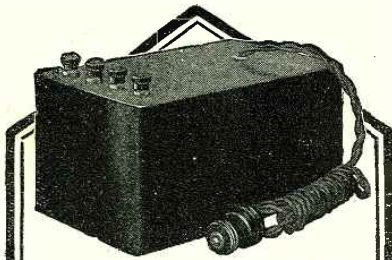

Marvelous
Townsend
"B"

SOCKET

Power Unit

Replaces "B" Batteries

Enjoy greatly improved reception and forget unreliable "B" Battery nuisance. Every part in the Townsend "B" Socket Power Unit is made and assembled in our own factory. That is why we can give you a high grade instrument at a startlingly low price, with a real guarantee of money back if not satisfied. Delivers up to 100 volts on any set, on direct or alternating current—any cycle. Full tone, clarity and volume. Just read these enthusiastic endorsements.

London, Ont., Canada.
I am very well pleased with your Eliminator. Since using it I have had many more stations and greater distance.
—C. E. Bond.

Dewey, Okla.
I am more pleased with your Eliminator than I was with batteries.
—B. E. Doureton.

Renovo, Penn.
I have received the Townsend Eliminator and it works fine.
—Clarence Witchey.

Great Barrington, Mass.
I have given your Eliminator a good test and find it very good.
—H. M. Miles.

Tested and approved by America's leading
Radio authorities—Radio News and
Popular Radio Laboratories.

ORDER TODAY!

Simply fill out the coupon and slip it into an envelope with only \$1.00 and mail at once. Your Townsend "B" Socket Power Unit will be sent promptly. Deposit only \$3.95 plus postage with the postman. Try out for 10 days—then if not delighted with improvement in reception, return it to us and purchase price will be refunded.

TOWNSEND LABORATORIES
713 Townsend St. Dept. 25 Chicago, Illinois

**10 Days
FREE
TRIAL**
You are the
Judge!

Attach
only \$1.00
to this
Coupon!

SEND TODAY

TOWNSEND LABORATORIES,
713 Townsend St., Dept. 25
Chicago, Ill.

Gentlemen: Attached find \$1.00. Kindly send at once Townsend "B" Socket Power Unit, C. O. D. for \$3.95, plus postage, on guaranteed 10-day free trial.

Name.....

Address.....

City.....State.....

The Effects of Shielding

(Continued from page 52)

former showed any great deviation from the curves given as an average.

The vacuum-tube or peak voltmeter employed was essentially the same as the one used by Moulin of England and several American radio engineers. The writer used in the plate circuit a sensitive galvanometer which enabled him to read the peak voltages of the alternating-current component to an accuracy within 0.1 volt. The accuracy of the voltmeter used in measuring the changes of applied grid potential remained the same regardless of frequency.

The calibrations of the radio-frequency oscillator were made by the use of a wave-meter the accuracy of which has been tested several times in conjunction with Chicago broadcast stations.

The oscillator used in connection with the intermediate transformers was slightly different from that used in the case of radio-frequencies. Its calibration was accomplished in a similar manner.

The process of experiment was as follows: at a given frequency the voltage transmitted by the transformer was measured in the absence of the shields. Two grounded shields were then brought towards the transformer, care being taken to keep them exactly perpendicular to the field. At intervals of 0.5 centimeter the voltage drop was measured. Also, with each different setting of the shields, measurements were made to see whether the resonance-frequency of the transformer unit had changed. The same procedure was followed several times, varying the frequency.

In the case of radio frequencies, a wave-band of from 500,000 to 1,500,000 cycles was investigated. With intermediate frequencies, from 37,000 to 65,000 cycles were used. Thus, by knowing the maximum voltage transmitted by the transformers at their resonance-frequency, in the absence of the shields, and by measuring the successive potential drops with the shields at different distances from the windings, it was possible to construct a curve showing the percentage of voltage-transmitted-decrease as the shield is brought towards the transformer. The voltage transmitted is directly proportional to the efficiency of the transformer.

The shifting of the resonance-point, above mentioned, was noticed only when a shield was brought towards the *tuned side of the transformer*. This fact is of great importance when working with matched transformers.

The curves shown were drawn through the points obtained from the different transformers. In all, six different makes of both radio and intermediate transformers were investigated.

The writer has no definite data on the effect of a shield which is not in the field of the transformer coils. Parallel to the field, a shield seems to show little absorptive power. In the respective positions, ranging from parallel to at right angles to the field, the absorption is inversely proportional to the angle the shield makes with the perpendicular.

An accompanying sketch, Fig. 3, shows the set-up of the general apparatus.

SAME OLD STORY

The Fisherman (who has taken up radio): I got Honolulu last night and you should have heard the stations that got away!—*Life*.

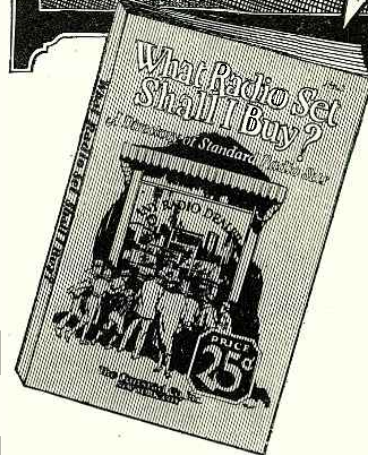

The first and only complete manufacturers directory of all Standard Radio Receivers

We all want to know what kind of a set is best to buy. Here is a book that describes all standard manufactured sets from authentic descriptions furnished by the *manufacturers themselves*.

It gives you all the information you need to make your choice, saves you from "blind" buying, and vain regrets.

GIVES PRICES, TECHNICAL DESCRIPTIONS—ILLUSTRATIONS

Receivers are illustrated, prices are given, manufacturers' names and addresses supplied. General characteristics of sets are described, number of tubes, "Electrified" Receivers, etc., etc.

All you need know—Just like a permanent "Show."

The only book of its kind—absolutely unprejudiced. 40 pages—size 6 x 9 inches, profusely illustrated.

DON'T BUY IN THE DARK—AVOID MAKING THE WRONG CHOICE

USE "The Directory of Standard Radio Sets."

**Only 25c
Sold Everywhere**

If your dealer cannot supply you
Write direct

The Consrad Company, Inc.,
230 Fifth Ave. New York, N. Y.

A Great Deal for a Very Little!

Ordinarily This Seems Too Good to Be True, But Here Is An Instance of Complete Verification



The New De Luxe Model Bretwood With Condenser Attached

WHEN you are deciding on what parts are to go into the receiver you are about to build, under no circumstances, dismiss the grid leak with only casual consideration. Respect the grid leak as something well worthy of expert choice.

The best course is to select a variable grid leak with an ample resistance range, one that may be mounted on baseboard, sub-panel or front panel, as you prefer.

Such a leak is the BRETWOOD VARIABLE GRID LEAK, which is now on the market in new de luxe model, representing improvements in mechanical strength, electrical efficiency and utility.

Higher Efficiency

You should use a variable grid leak like the BRETWOOD VARIABLE GRID LEAK in a set you are about to build, or should put one in your present receiver, because it will enable you to get highest operating efficiency from the detector tube. As nearly all tubes used as detectors draw grid current, the resistance value of the leak is important for biasing and discharging purposes. Not only can exactly the right degree of flow be established to discard excess electrons, but the grid-to-filament impedance is so affected as to afford

best selectivity under the circumstances. Only a variable leak gives this precision choice.

You prevent overloading of the detector tube by correct leak setting. This improves tone quality considerably. Often if your set sounds distorted, this is immediately and permanently remedied. Hence you reap greater volume, better selectivity and purer tone quality—all by the simple insertion of a BRETWOOD DE LUXE MODEL VARIABLE GRID LEAK.

Selected by Bernard

This efficient instrument so struck Herman Bernard that he prescribed it for his latest and most popular circuit, Radio World's Universal Four-Tube Receiver.

THE BRETWOOD DE LUXE MODEL VARIABLE GRID LEAK costs \$1.75—a small enough price for so much efficiency. If desired, a .00025 mfd. BRETWOOD BULLET CONDENSER is supplied, mounted on the leak, at 50 cents extra.

Note: The Bretwood Leak's range is .25 to 10 meg.

Dealers: Send in your orders direct!

North American Bretwood Co.,
141 West 45th Street, New York City.

Gentlemen: Enclosed find \$1.75. Send me at once one De Luxe Model Bretwood Variable Grid Leak on 5-day money-back guarantee. (Or \$2.25 for leak with grid condenser attached).

NAME

ADDRESS

CITY STATE

Inquiries Solicited from the Trade

B. S. T. CONE SPEAKER

Guaranteed to give Satisfaction in Tone, Volume and Appearance

Adjustable to Volume Desired



18 inches in diameter edged in Gold Braid. Art Metal Base can be placed on highly polished surface without danger of scratching.

Immediate Delivery

\$7.50

Shipped Direct from Factory

Satisfaction Guaranteed or Money Back

GUARANTY RADIO GOODS CO. 141 West 45th St., New York

The whole
COUNTRY
is
praising
AMERICA'S
FIRST
RADIO
ENCYCLO-
PEDIA



\$2

A place in every
home, every library,
every laboratory

S. GERNSBACK'S RADIO ENCYCLOPEDIA is the only standard work ever published in America attempting to classify alphabetically the countless words used in the highly specialized science of RADIO. The ENCYCLOPEDIA is written in plain English so that everybody can understand the definitions and descriptions.

No expense has been spared, covering over two years in compilation, to make it worthy a place in your library.

It is published in one volume—168 pages—size 9x12 inches, nearly an inch thick and nicely accommodates the beautiful illustrations and the large, easy to read type.

Every page is replete with illustrations—to make the text easily understandable.

REMEMBER THIS IS A REAL ENCYCLOPEDIA—NOT A DICTIONARY—and very few of the things described and illustrated in this volume can be found in any dictionary, or any other encyclopedia.

The book contains as a supplement a classified cross-index designed to bring together radio references under one heading having relations in common.

All circuits new and old are described by word and picture and every part and apparatus used in Radio is explained and made understandable by means of photographs and drawings.

The work contains 1,930 definitions, 549 photographs, drawings and diagrams.

Order Direct from
S. GERNSBACK
230 Fifth Ave., New York

NEW YORK, N. Y. . . . It is the best work of the kind we have ever seen and shows considerable painstaking and laborious effort.—*Telegram*.

NEW YORK, N. Y. . . . The volume amounts to practically a compact review of all that has been done in radio up to this time.—*Radio*.

WASHINGTON, D. C. . . . It presents a complete classification of the latest authoritative data in radio.—*Evening Star*.

SAN FRANCISCO, CAL. . . . A book that will be of value to all that are interested in practical radio work.—*Examiner*.

PITTSBURGH, PA. . . . Many radio fans will be interested in the new Radio Encyclopedia by S. Gernsback.

PITTSBURGH, PA. . . . It is a complete classification of the latest authoritative data in radio.—*Daily Tribune*.

CHICAGO, ILL. . . . Mr. Gernsback is author of other volumes on radio and his encyclopedia may be recommended as authoritative.—*Daily Press*.

CHICAGO, ILL. . . . S. Gernsback has aimed to provide not merely a dictionary of radio terms but an actual ready reference encyclopedia.—*Herald and Examiner*.

ST. LOUIS, MO. . . . S. Gernsback's new radio encyclopedia holds all needed facts.—*St. Louis Star*.

ST. LOUIS, MO. . . . A book of radio information is S. Gernsback's radio encyclopedia.—*Globe Democrat*.

MACON, GA. . . . Gernsback's radio encyclopedia fills a demand that has been made by every radio fan as well as technical expert since the industry has started.—*Telegraph*.

DALLAS, TEXAS. . . . This encyclopedia is readily understandable to anyone who reads English and is thorough and readable.—*Sunday News*.

LOS ANGELES, CAL. . . . Its references cover every item of importance relative to the radio industry.—*Sunday Times*.

OTTAWA, CANADA. . . . It is an encyclopedia in the true sense of the meaning and not a mere dictionary.—*Journal*.

NIAGARA FALLS, N. Y. . . . The volume may be recommended for every radio listener.—*Evening Review*.

BUFFALO, N. Y. . . . Here is the world of radio, all in one volume, and it is one of the most comprehensive, enlightening and illuminating publications that has yet been issued.—*Courier-Express*.

BRIDGEPORT, CONN. . . . All radio terms are fully described in layman's style, and the explanation of the whys and wherefores of various circuits are also given.—*Herald*.

BOSTON, MASS. . . . A practical handbook with references covering every item of importance relating to radio.—*Globe*.

PHILADELPHIA, PA. . . . In his Encyclopedia Mr. Gernsback has succeeded in reducing high sounding electrical and technical terms to every day speech.—*Daily News*.

Loud-Speaker Coupling Devices

(Continued from page 25.)

TRANSFORMER PASSES A.C. ONLY

As mentioned previously in this article, just as soon as the filament switch is pulled out and the rheostats turned on, a direct current starts circulating in the winding of a directly-coupled loud speaker. However, where a coupling transformer is used, its primary winding takes the place of the loud-speaker windings, and the direct current flows only in the primary. It is evident therefore, that the latter winding is surrounded by a magnetic field. Just as soon as the alternating-current component produced by the incoming signal circulates in the primary, the magnetic field starts varying in intensity; because the direct current is varied or "modulated" by the A.C. component. This varying magnetic field induces in the secondary winding a current which corresponds to the music or voice which was transmitted by the broadcast station.

Quality Reproduction

(Continued from page 27)

they reach the detector. To avoid this, the tuning of individual stages must be broadened; which operation of course affects adversely the selectivity of the set. The requisite individual-stage damping, together with sufficient over-all selectivity, can be gained by increasing the number of tuned stages. A T.R.F. system having a number of properly-damped tuned circuits becomes a sort of band-pass filter, with the output impedances of the coupled amplifying tubes acting as the series-coupling impedances (Fig. 3).

Such a system can be designed to produce negligible frequency-distortion of the audio band. Of course the detector that follows the tuned stages will, if it be of the ordinary variety, cause the usual form of distortion; the remedy is the same as that previously mentioned.

The third R.F. system ordinarily preceding the detector is a simple regenerative circuit, or a regenerative circuit following one or more stages of R. F. Such a combination can be made very sensitive to weak signals, when the regeneration principle is skillfully applied. But, when high regeneration is used, the damping of the tuned circuit in which it takes place is considerably decreased, the selectivity goes up, and the attendant drawback of increased selectivity follows; that is the higher audio frequencies are depreciated.

(The second part of this article will appear in the August number of RADIO NEWS.)

ANOTHER RADIO TERM

"I SHALL expect to hear news from valve Barts (English for eloquent owners of DX-getting tube sets) of WRNY, New York City," says "Ariel" the sprightly editorial writer of *Popular Wireless*, London, under the heading "When Is An Aerial Not?" "This will be the first station in America, it is claimed, to broadcast from a buried aerial. So far as I know, it can have the world rights, too. But it will be a most interesting experiment, both for the transmitting engineers and the public. I suggest the wire should be called a 'burial,' not an aerial."

The same writer hears incredulously of sets to tap transatlantic conversation, and is confident that he voices 100% of the British public in saying "It's not done." (You'd be surprised.)

S. GERNSBACK 230 FIFTH AVE., N. Y.
I enclose \$2.00 for one copy of your encyclopedia.
Name.....
Address.....
City.....
State.....

WORLD Radio Units Save You 50%

"A" Current

From
Your
Light
Socket

World

"A" POWER UNIT

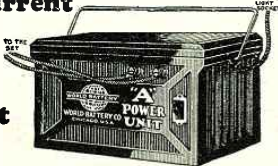

Automatically provides even, unvarying "A" current from the moment you throw on your set switch. A marvelous improvement—at less than half the cost of any similar equipment. Finer reception, uninterrupted by "fades" and "screeches." Absolutely noiseless. Assures full tone quality from your set and wider D X range. Shipped complete, subject to inspection, on receipt of price—C. O. D. if you wish.

25 Amp. Unit for sets of 4 tubes or less—\$12.75
60 Amp. Unit for sets of 5 tubes or more—\$15.75

\$12.75



**Clearest
Truest "B"
Power with
World Radio
Storage**

"B" Batteries 12 Cell
24 Volt

Sturdy construction. Solid Rubber Case protection. Re-charged for almost nothing. Endorsed and listed as standard by Radio News Lab., Pop. Radio Lab., Pop. Sci. Inst. Standards, Lefax, Inc. and other famous Radio Authorities.

Send No Money Just state number wanted, order is received by Express, C. O. D., subject to examination. 5% discount for cash with order.

Extra Offer: 4 Batteries in series (96 volts) \$10.50.

**Radio Storage "A"
Battery—6 Volt**

Unequaled battery value! 25 ampere capacity. Ideal for Trickle Charger. Solid Rubber Case. Shipped C. O. D., subject to inspection, for only \$5.00. Send to-day. 5% discount for cash with order on any World Unit.

\$5.00



WORLD BATTERY COMPANY

1219 So. Wabash Avenue

Dept. 75

Chicago, Illinois

Set your radio dials at 288.3 meters for the World Storage Battery Station, W 8 D C. Variety—New Talent—Always Interesting.

\$75 to \$125 Weekly

5 Down
Charging Batteries
Starts You

Let me show you how to make big money right from the start. I've prepared a FREE book explaining all details. First week's profit pays for all equipment. You can get all the battery charging business in your community with my Service Station Charger—it's years ahead of ordinary chargers—handles 50% to 70% more batteries. I explain everything—start you in a business of your own and put you on the way to big money. Write for FREE BOOK.

C. F. HOLMES, Chief Engineer, Dept. 100
Independent Electric Works
5116 Ravenswood Ave. Chicago, Ill.

FREE BOOK—Just Out

STAMMER

Send 10 cents for 238-page book on Stammering and Stuttering "Its Cause and Cure." It tells how I cured myself after stammering 20 yrs. B. N. BOGUE, 6969, Bogue Bldg., 1147 N. 111 St., Indianapolis.

The Stroboddyne

(Continued from page 29)

a frequency changer is also a detector. Since a detector produces in the plate circuit a variation equal to the square of the applied grid voltage, it follows that a very weak signal produces barely any variation in the plate circuit. On the other hand, an amplifying tube produces in the plate circuit a response which is proportional to the amplifying characteristic of the tube and to the voltage applied to the grid. The difference in sensitiveness between the two systems is readily apparent when weak signals from distant stations are being received.

On a very weak signal the amplification obtainable with the Stroboddyne is equivalent to that of a standard superheterodyne with a stage of radio-frequency amplification ahead of it. The Stroboddyne with one stage of T.R.F. is tremendously sensitive, the addition also improving the selectivity considerably. This, however, introduces a third control. The main problem is the connection of the R.F. stage.

This may be done as shown in Fig. 5 by taking a tap on the secondary of the transformer; but we have found that the following arrangement is better. The circuit is drawn in Fig. 6. The R.F. transformer has three windings: the primary, connected in the plate circuit; the secondary, which is tuned; and the coupling-winding T, which reduces the damping effect upon the tuning circuit. The secondary condenser may be grounded (as indicated by the dotted line) to prevent body-capacity effects in tuning.

One might say that, because of the fact that the winding, T, has fewer turns than the secondary, only a fraction of the received energy is applied to the grid of tube V2; but, as explained previously, this depends on the damping effect of the tube; and the less the damping the greater the energy transmitted through the circuit.

RESULTS

We now have the main facts about the new Stroboddyne. It is new in that it has never before been described, although it has been in actual use for several months. The first tests were made over a year ago, but we did not want to describe the circuit before becoming fully acquainted with it. All our friends, both engineers and amateurs, who have witnessed its performance declare the set to be far ahead of other systems, regardless of the number of tubes used. It is possible to receive on a loud speaker, in Paris, stations in Berne, London, Rome and Prague, with one stage of audio amplification and a loop antenna one foot square.

A complete description of the construction of a Stroboddyne receiver will appear in the August number of RADIO NEWS.

A Traveler's Set

(Continued from page 46)

and it will do well on 45 volts of "B," though 90 volts will be better. For an "A" battery, get a small three-cell "C"-type battery of the kind which measures about $3\frac{1}{2} \times 2\frac{1}{2} \times 1$ inch. For a "B" battery, buy two of the smallest blocks of 22½ volts each. These are just a little wider than the aforementioned "A" battery. If you buy them at the right place they will cost about one dollar each. Elsewhere they may cost fifty per cent more. The writer has slipped these three blocks of battery into a con-

PUBLIC SPEAKING SIMPLIFIED

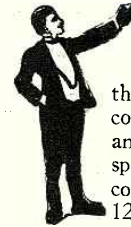

This book is for the busy man or woman and all those who wish to overcome self-consciousness and cultivate the art of speaking with ease and confidence. 100 pages. 12mo. cloth.

Postpaid \$1.00

The Vest Pocket Bookkeeper

and Short Cuts in Figures

A simple and concise method of Practical Bookkeeping with instructions for the correct keeping of books of account. How to take off a trial balance sheet and finally close and balance accounts.

The perfect self-teacher. 160 pages.

Postpaid \$1.00

The Real Estate Educator

The Encyclopedia of Real Estate which insures success in the real estate business. It contains valuable information on selling, buying, advertising, appraising, investigating, leasing, insuring, and mortgages. Just what you want to know, need to know, and ought to know in simple, practical usable form. Cloth binding. 208 pages.



Postpaid \$2.00

The Vest Pocket Lawyer

Here at last in a single volume—a complete law course—clearly analyzed in understandable English. A daily guide for the business man—the law student—the justice of the peace—the notary public—the farmer—the clergyman—the merchant—the banker—the doctor. Just as the lawyer advises. The only book of its kind. 360 pages, cloth.

Postpaid \$1.50

The Vest Pocket Cushing

Just out. An A. B. C. Guide to Parliamentary Law based on the highest authorities and adapted to general use—containing model speeches and toasts for all occasions. 128 pages, leatherette.

Postpaid \$1.00

THE CONSRAD CO., Inc.
230 Fifth Ave., New York, N. Y.

I enclose \$..... in payment of the books checked below:

- The Real Estate Educator \$2.00
- The Vest Pocket Bookkeeper \$1.00
- The Vest Pocket Lawyer \$1.50
- Public Speaking Simplified \$1.00
- The Vest Pocket Cushing \$1.00

Name

Street

City State

venient card-board box. This outfit weighs three pounds. The "A" battery will run many hours, while the "B's" will last for months.

A further word should be said about the aerials. It is often convenient to have a forty-foot length of flexible insulated wire—loop wire—with a phone tip soldered on one end. This wire can easily be wrapped on a spool. It will drop out of a third-story window and make a fairly successful antenna. It weighs very little, with reasonable care it will not "snarl," and it needs no insulators. Any old kind of a stick, held in place by the window sash, will improve its effectiveness by keeping it a foot or so away from the wall.

An eight-foot length of the same wire, with a spring clip on one end and a phone tip on the other, will make a convenient ground connection with the radiator or water fixture. A similar piece of wire will connect the light-socket antenna when it is to be used. All three of these wires can be rolled on the same spool.

Connections from set to battery are made by means of three flexible insulated wires, each 8 inches long and with phone tips soldered to both ends. It is a valuable insurance to use a different color for the "A+B—" common lead. Mark on the wood above each jack, using pen and ink, what its connection is.

OPERATION

A light-socket antenna will, under favorable conditions, bring in stations five hundred miles away, but a good outside aerial is, of course, better.

Rotate the dials slowly and if there is a local station on you will get a big earful. Then adjust the crystal for maximum sensitivity and go after what you want within reasonable distance.

If the set howls, the crystal contact is not good. A touch on the catwhisker will stop the racket. There is a bare possibility that a .001-mf. fixed condenser across the secondary of the audio transformer may increase volume. Probably not.

The right-hand dial is not as sharp in its tuning as that on the left but, should the right-hand control have no clearly marked peak, there is too much resistance somewhere in its circuit. It may be in the crystal contact, or it may be a poor connection.

The writer, living near KGO, Oakland, can tune it out in about five numbers on the dials and easily pick up the little locals without a background from the 5,000 watts of the big fellow. He easily hears 500-watt stations in Los Angeles, over 400 miles away on a 50-foot antenna.

The writer paid for all parts exclusive only of tube and batteries, but including one hundred feet of stranded wire, light-socket-plug antenna, phone tips, and clips, just \$9.90.

CIRCUMSTANTIAL EVIDENCE



ARTIST: "Whenever I'm working on a painting I turn on my radio. It inspires me to do my best work."

VISITOR: "The static must have been terrible the day you did this one!"

Announcing---the First AMAZING STORIES "ANNUAL"

132 PAGES

SIZE 9x12 INCHES

featuring

The Master Mind of Mars by EDGAR RICE BURROUGHS

A remarkable new story by this famous author of the "TARZAN" Series. *It has never before been published.*

Also

A carefully selected group of the most important stories that have appeared in *Amazing Stories Magazine* for the past year.

50c THE COPY

EXPERIMENTER PUBLISHING COMPANY, Inc.
230 Fifth Avenue, New York, N. Y.

Gentlemen—I enclose 50c for one copy of your book "AMAZING STORIES ANNUAL" as advertised above.

Name

Address

City, State

**Best by YOUR test—
a confident challenge!**

For All
Power Work



Pat. Pend.

12 Watts
These units do not deteriorate or change in resistance value.

**EL MENCO
HY-WATT
TRADE MARK
HEAVY DUTY
RESISTORS**

For best results with Raytheon and other power circuits you must have permanently accurate resistors capable of carrying heavy loads without change or deterioration. "HY-WATT" Heavy Duty Resistors dissipate up to 12 watts.

- 100-500-1000-2000-5000 ohms \$1.25
- 10,000-25,000-50,000 ohms \$1.50
- 100,000 ohms \$2.00

Write for full details and literature on El Menco Gridleaks and Resistors
Electro-Motive Engineering Corp.
127 West 17th St. New York, N. Y.



**MYSTERY
3 COIL UNIT**

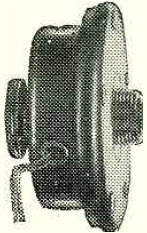

Clearer—Louder
Distortionless
Radio Amplifier
Power tube
Unnecessary

**MYSTERY
3-COIL UNIT**

Will Carry Any Desired Voltage

Attach it to any console or speaker. No rust—no corrosion—moisture proof, enduring.

**\$12.50 Value
Introductory offer \$4.95**

Dealers write for prices.

FRANK W. WOOD, U. S. Rep.
416 S. State Chicago, Ill.

FIRST CLASS

TRICKLE CHARGER \$2.50

Post Paid IN U.S.A.

When Cash Accompanies Order. Complete parts 6 ft. extension cord—nothing else to buy. Simple instructions, screwdriver, pliers and 30 min. work. Guaranteed to work on any A.C. socket.

X-L RADIO SALES, Dept. RN
2424 Lincoln Ave., Chicago, Ill.

ELECTRICITY—EASY AT LAST!
Learn By Doing in 90 Days

NO BOOKS—NO LESSONS. Big jobs waiting to pay \$50 to \$200 a Week. Come to COVNE for 90 days then get one. Learn by doing. COVNE gives you training and experiences. Write for the FREE book and FREE R. F. Fare offer. **COVNE ELECTRICAL SCHOOL, 1300 W. Harrison St., Dept. E7-77 Chicago, Ill.**

RADIO JINGLES

THE RADIO PESTS

We're so fed up with ancient jokes
Some day we're going to strike
The guy who starts a story with
"Two men named Pat and

The worst of all, we'd like to kill—
You know just why we rave—
He is the Bloop who adds his squeal
To our pet station's

—L. W. Tufford.

GETTING IT ALL WITH ONE

There was a young husband named Rube
Who was an incurable boob;
He complained to his mate
Of the food on his

Now he dines through a hospital
—Mrs. Bernice West.

A GOOD RECEIVER'S A SET

I once knew a maiden named Mary,
But I lost that sweet little fairy
When I told her "You bet
Compared with my

"Sweet Mary, you are just
—Norris E. Wilson.

HE TRIED FOR LONDON

The crystal scratcher gave a sigh,
And said "I know the reason why
This little set won't go—
Its is 2LO!"

—Rudolph Sturm.

FOR each Radio Jingle accepted and printed, RADIO NEWS will pay \$1.00 per stanza. These should be humorous, novel, and deal with radio in allusions or subjects. The rhyme and meter must be reasonably correct; and the most obvious rhymes have been already used.

Address Radio Jingle Editor, RADIO NEWS, 230 Fifth Ave., New York City.

RADIO MOTHER GOOSE

I had a brainless husband, no bigger than my thumb;
I set him by my radio to listen to its hum;
He amplified the grid leak, detected it was dumb—
Alas, my tubes, my rheostat, my set, are on the bum!

—Mrs. George Gamble.

"CANNED MUSIC"

I have a set that's different;
It's just like pork and beans—
I try to tune in KOA,
And in comes New Orleans.

—Mildred Odle.

I Want to Know

(Continued from page 62)

loose-coupled Hartley circuit, including constants of coils, condensers, etc. I intend to operate on the 40-meter band. What is the correct length of aerial and counterpoise for operation at this wavelength?

A. 1. The circuit you request is shown in Fig. Q. 2225, with the values of the various parts indicated. The Hartley circuit is reputed to be the simplest and most efficient circuit for use in amateur transmitters. This is attested by the fact that 90 per cent of all transmitting amateurs are at present employing this circuit in one form or another.

Two inductances are used, a primary or tuned circuit and a secondary or antenna coil. The emitted wave depends on the adjustment of the

(Continued on page 74)



SPARETIME MONEY Handbook

Approved Plans For Securing Additional Incomes
Compiled by the Staff of

SPARE-TIME MONEY MAKING

PRICE 50c

The Conrad Co. Inc. NEW YORK CITY

**—do YOU
have to be
shown—**

YOU have most certainly read many reports of men and women who have built up, in their sparetime, solid, substantial and big income businesses. Perhaps you are skeptical, but these stories are far from being the "bunk"—Sparetime businesses are real—and often bring amazing incomes. If you are one of those who have to be shown the means to make a success from a Sparetime business, spend 50c (only) for the book displayed above.

67

PLANS TO MAKE MONEY

It contains no less than 67 definite, practical and workable money making plans—selected as the best for the average man.

Each plan consists: First—of an item that can be retailed by people of limited means and have only a few spare minutes a day to utilize. Second—The best method of production is outlined carefully with suggestions as to what to avoid. Third—Avenues of distribution or selling are given—such methods of selling by mail as are applicable and all similar details are discussed, and Fourth—information of importance in carrying on to reap large, generous profits is discussed.

Sparetime Money Handbook contains 100 Pages, of the large magazine size, 9 x 12 inches—with handsome colored covers, over 100 illustrations.

NEW EDITION JUST OFF THE PRESSES

Price 50c

If your dealer cannot supply you use Coupon below

THE CONRAD CO., Inc.,
230 Fifth Ave., N. Y.

Gentlemen: I enclose 50c for one copy of "Sparetime Money Handbook."

Name

Address

City, State



An advance showing of RMA Exhibits STEVENS HOTEL, CHICAGO-JUNE 13-18

LIST OF EXHIBITORS

- The Alox Co.
- Acme Apparatus Co.
- Acme Elec. Mfg. Co.
- Acme Wire Co.
- Adler Mfg. Co.
- Aero Products, Inc.
- Acrovox Wireless Corp.
- All-American Radio Corp.
- Allen-Bradley Co.
- Aluminium Co. of America
- American Bosch Magneto Corp.
- American Elec. Co., Inc.
- American Mechanical Labs.
- Ambition Corp. of America
- Ameco Products, Inc.
- F. A. D. Andre, Inc.
- Apex Elec. Mfg. Co.
- Atwater-Kent Mfg. Co.
- Audiola Radio Co.
- Baritone Mfg. Co.
- Belden Mfg. Co.
- Benjamin Elec. Mfg. Co.
- Burkman Radio Corp.
- Bosworth Elec. Mfg. Co.
- L. S. Brach Mfg. Co.
- Bremer-Tully Mfg. Co.
- Briggs & Stratton Corp.
- Brooklyn Metal Stamping Co.
- Brown & Caine, Inc.
- Buckwater Radio Corp.
- Burgess Battery Co.
- Camfield Radio Mfg. Co.
- Cannon & Miller, Inc.
- Carter Radio Co.
- C. E. Mfg. Co., Inc.
- The Celeron Co.
- Central Radio Labs.
- Compressed Wood Corp.
- Continental Fibre Co.
- Contra Wire Co.
- Crosley Radio Corp.
- Crowe Name Plate & Mfg. Co.
- E. T. Cunningham, Inc.
- Daven Radio Corp.
- De Forest Radio Corp.
- De Jur Products Co.
- Tohe Deutschmann Co.
- Diamond Elec. Specialty Corp.
- Diamond T. Radio Mfrs.
- Diamond Vacuum Prods.
- Dongan Elec. Mfg. Co.
- Dubilier Cond. Corp.
- Eagle Charter Corp.
- H. H. Eby Mfg. Co.
- The Ekko Co.
- Electrad, Inc.
- Elec. Research Lab.
- Elkon Works, Inc.
- Fansteel Prod. Co., Inc.
- Farrand Mfg. Co., Inc.
- John E. Past & Co.
- Federal-Brandes, Inc.
- Federal Radio Corp.
- J. B. Ferguson, Inc.
- Ferranti, Ltd.
- Forest Elec. Co.
- Pornica Insulation Co.
- Freed-Eisenmann Radio Corp.
- French Battery Co.
- Chas. Freshman Co., Inc.
- Herbert H. Frost, Inc.
- General Inst. Corp.
- General Radio Co.
- Gold Seal Elec. Co., Inc.
- Gold Storage Bat. Co., Inc.
- Greene & Brown, Mfg. Co.
- Grisby-Grunow-Hinds Co.
- Hannarlund Mfg. Co., Inc.
- Howard Radio Corp.
- Hoyt Elec. Inst. Co.
- Imperial Molded Prod. Corp.
- Indiana Mfg. & Elec. Co.
- International Resistance Co.
- Ivington Varnish & Inst. Co.
- Jefferson Elec. Mfg. Co.
- Jewell Elec. Inst. Co.
- Johnson Motor Prods. Co.
- Howard H. Jones
- Karas Elec. Co.
- Kellogg Sw. & Supply Co.
- Keystone Radio Labs.
- King Mfg. Co.

LIST OF EXHIBITORS

- Kodak Radio Corp.
- The Ligotte Corp.
- Arthur H. Lynch, Inc.
- The Magnavox Co.
- Maring Wire Co.
- Martin Copeland Co.
- Mohawk Corp. of Illinois
- Leslie F. Miter Co.
- Murad Radio Corp.
- Wm. Murdock Co.
- National Carbon Co.
- Newcombe-Hawley, Inc.
- O'Neil Mfg. Co.
- Paragon Elec. Corp.
- Perryman Elec. Co., Inc.
- Pfanstiehl Radio Co.
- Philadelphia Storage Battery
- Platter Cabinet Co.
- Polymet Mfg. Corp.
- Pooley Co.
- Potter Mfg. Co., Inc.
- Precision Prods. Co.
- Premier Radio Corp.
- Prest-O-Lite Co., Inc.
- G. H. S. Music Co.
- Radio Corp. of America
- Radio Master Corp. of Amer.
- Raytheon Mfg. Co.
- Reichmann Co.
- Runzel-Lenz Elec. Mfg. Co.
- Sandar Corp.
- Samson Elec. Co.
- Santano Elec. Co.
- Seoville Mfg. Co.
- Sentinel Mfg. Co.
- Shameck Mfg. Co.
- Showers Bros.
- Slagle Radio Co.
- Sonora Phonograph Co., Inc.
- Sonatron Tube Co.
- Sparks-Withington Co.
- Splittdorf Elec. Co.
- Standard Piano Bench Co.
- Steinbo Labs.
- The Sterling Mfg. Co.
- Stevens & Co., Inc.
- Stewart Battery Co.
- Stewart-Warner Speed. Corp.
- Sunlight Lamp Co.
- Superior Cabinet Co.
- Timmons Radio Products Corp.
- Tower Mfg. Corp.
- Trimm Radio Mfg. Co.
- Triple A. Spec. Co.
- Tyman Elec. Corp.
- Universal Battery Co.
- Utah Radio Products Co.
- U-S-L Radio Co., Inc.
- U. S. Tool Co., Inc.
- United Radio Corp.
- Walley Elec. Corp.
- The Van Home Co., Inc.
- Vesta Battery Co.
- W-K Elec. Co.
- Walbeet Mfg. Co.
- Geo. W. Walker Co.
- Webster Elec. Co.
- The Webster Co.
- Wells Radio Mfg. Co., Inc.
- Westinghouse Union Batt. Co.
- Weston Elec. Inst. Corp.
- The Workite Mfg. Co.
- Yale Elec. Co.
- Yaxley Mfg. Co.
- Zenith Radio Corp.

THE first annual trade show of the Radio Manufacturers' Association will open at the new Stevens Hotel, Chicago, Illinois, June 13th, 1927, a few days after this number of RADIO NEWS appears. In the exhibition hall of the hotel, which is one of the largest buildings of its kind in the world, more than one hundred of the leading radio firms of the country will gather for the purpose of establishing important apparatus standards for the industry as a whole and of displaying advance models of new receivers, accessories, and parts that ordinarily would not be shown until the early fall.

Although the exhibition will be a trade show in the full sense of the term, (admission being limited to manufacturers, jobbers, dealers, members of the press, and such other persons as the Show Committee decides to invite), the matters to be discussed and the material to be displayed are of such immediate interest to users of radio in general that RADIO NEWS, in its capacity as the largest of all radio magazines, has arranged for a public announcement of the outstanding features of the affair by means of this special show issue. A number of representative manufacturers have taken space to describe their products in detail and to express their individual ideas; their advertisements contain information and news of new developments that every radio-set owner, or prospective buyer can read with profit.

(Continued on page 82)

- TRADE PAPERS**
- Citizens Radio Call Book
 - Experimenter, Pub. Co.
 - RADIO NEWS
 - [RADIO LISTENERS GUIDE]
 - McGraw-Hill Cat. & Dir.
 - Merchandising Magazines, Inc.
 - Phonograph and Talking Machine Weekly
 - Radio Dealer Pub. Co., Inc.
 - Radio Engineering
 - Radio Repairing
 - Talking Machine Journal
 - Talking Machine World

Announcement

Sterling

"A" LIGHT-SOCKET POWER UNITS

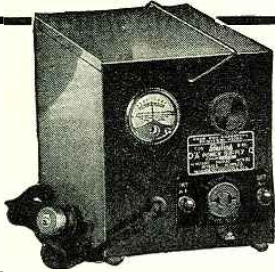

They're here—two perfected light-socket power supply units—eliminators of all "A" batteries and chargers.

Two models—R-96-Raytheon for 6 volt and R-94-G. E. bulb for 4 volt, Radiolas especially.

Sterling model R-96 is universal for all sets using 3 to 10 large tubes. Employs Raytheon's new 2 1/2 ampere rectifier. No heat—no bulb—no breakage—long lived.

Sterling indicator makes this unit adjustable to point of highest operating efficiency and lowest power cost.

These units have two stages of filter, large capacity, smoothing out the last trace of hum.

Automatic switch gives instant control of all power when used with "B" eliminator or "B" batteries.

One installation, one adjustment—and your "A" troubles are ended. Ask your dealer to show you this remarkable Sterling "A" Power unit.

Sterling

"A" POWER UNITS

The Sterling Mfg. Company
2831-53 Prospect Ave., Cleveland, Ohio

Dealers—Don't miss the complete Sterling display at the Chicago R. M. A. Show, Booth 68.



FROST-RADIO

BAKELITE and METAL FRAME RHEOSTATS

These rheostats are the neatest, most compact long-service rheostats on the market. Windings are genuine nichrome wire of highest quality and cannot burn out under load for which they are designed.

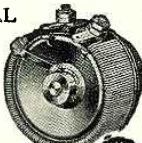

Bakelite Type, 2 1/2 to 75 ohms, 75c.

Bakelite Potentiometer, 200 and 400 ohms, \$1.00.

Metal Frame Rheostats, 2 1/2 to 75 ohms, 50c.

Metal Frame Potentiometers, 200 and 400 ohms, 75c.

HERBERT H. FROST, Inc.,
Main Office and Factory

Elkhart, Ind.

Chicago Pittsburgh New Orleans
New York Philadelphia St. Paul
Boston Washington, D. C. Los Angeles
Buenos Aires, Argentina

(Continued from page 72)

primary circuit, which after being tuned to the required wavelength, is brought into resonance with the antenna coil by means of the antenna tuning condenser, and the proper adjustment of the coupling between the inductances. Both plate and grid condensers can be .002-mf.; but this value is not critical on the short wavelengths, and capacities as low as .0005-mf. can be used with good effect. The grid leak may be of any convenient value from 5,000 to 20,000 ohms, depending on the characteristics of the tube; a higher value usually reduces the plate current and results in a steadier output. Where low power is used, such as a 201A or a 112 tube with about 200 volts on the plate, both grid leak and condenser may be dispensed with, with no great difference in results.

The radio-frequency choke placed in the plate lead is employed to prevent the oscillatory currents from backing up into the power source, with the results of loss of efficiency and unstable operation. This choke can be easily constructed by winding on a 1 1/2-inch form 150 turns of No. 30 D.C.C. wire. This winding should not be of the single-layer type, since the resultant increase in distributed capacity will defeat the purpose of the choke and by-pass some of the radio-frequency current. A scramble-wound coil on a spool of the correct diameter, will be satisfactory.

A storage battery should be used for filament supply; but, if larger tubes are employed and the current drain is excessive, a filament transformer will prove more economical. This transformer should be provided with a center tap, to which is connected the negative high-voltage lead and the filament tuning clip. For best results, a .002-mf. by-pass condenser is connected across each half of the filament winding. Keying can be done in the negative high-voltage lead.

The primary inductance, for 40 meters, should consist of 12 turns of No. 10 copper wire wound to a diameter of 3 inches; the antenna coil of 6 turns of the same size wire having the same diameter. A variable tuning condenser may be used across the primary coil, but is not absolutely essential; since the coils have inherent sufficient capacity for the proper oscillation of the circuit. The coupling between the primary and the secondary should be kept as close as may be consistent with a steady output; since close coupling results in a maximum transfer of energy. The aerial and counterpoise may each be about 30 feet in length, so that the transmitter is operated at or very close to the fundamental wavelength of the system. However, it has been found that results more uniformly consistent are obtained when the transmitter is operated on a harmonic of the antenna; and in most cases the third harmonic is used. When operating on this harmonic, the aerial and counterpoise should each be about 90 feet long, including the lead-in. Height in a short-wave antenna is not quite as important as in antennas designed for operation on the higher waves; but if it is convenient, the aerial should be made as high as possible.

Short-Wave Experiments with Ultra-Violet Rays

(Continued from page 59)

ground, because the earth's field must take no part in the experiments.

The supply of current for the arc lamp is taken from a Bosch battery; as much as possible of the disturbing effect of the arc upon the receiver is filtered out.

ANALYSIS OF RESULTS

The results obtained when using the ultra-violet beam as an antenna were found to be dependent upon the climatic conditions and the direction in which the beam was pointed. In the latter respect, the best results were obtained when the beam was either perpendicular to or in the magnetic meridian; but the distance over which a station can be worked is as yet unknown. That the weather plays an important part in the experiments will be seen from a perusal of the following data:

Good Reception

Most favorable wavelength range, 10 to 50 meters; clear sky; humidity, 30%; temperature, cool; direction of beam, perpendicular or north.

Fair Reception

Most favorable wavelength range, 10 to 120 meters; humidity, 50%; temperature, cool; direction of beam, east.

No Reception

Wave-length range, 120 meters and above; cloudy sky; humidity, 70%; rain, moonlight and daylight.

Centralab "Highly Regarded Radio Products"

CONSISTENT built-in quality, smooth, unvariable long-life performance have created a lasting friendship for Centralab Products. Manufacturers desirous of trouble-free service in their products are consistently using Centralab Controls. The Radio fan, who builds his own, recognizes this quality. Thus, Centralab has come to mean the "better control" for radio. Popular usage has made it so.

Centralab has several new products this season. They will be shown at Booth No. 3 at the R. M. A. Exhibit. They are especially worthy of your investigation.

Centralab Products

Radiohms Potentiometers
Modulators Rheostats
Heavy Duty Radiohms and Potentiometers for "B" Eliminators

Heavy Duty Wire-Wound, heat-proof Rheostats and Potentiometers
Wire-Wound Fixed Resistances for light socket power supplies

Accessories
Modu-Plugs Station Selector
Tone Amplifier

Central Radio Laboratories
19 Keefe Avenue Milwaukee, Wis.

12 P.M. Gives up in disgust!

The man who forgot to buy

THE RADIO TROUBLE FINDER

FROM 8 o'clock to 12 he was frantically trying to tune in on the big anniversary program, but his radio set positively would not work.

He had a dozen books on the care of his car but not one for his Radio.

Radio Sets rarely need an expert's attention, if you have a copy of "The Radio Trouble Finder," handy.

It's a 68-page, simplified manual for trouble correcting—written expressly for home users.

Common Radio faults are charted and remedies are given in language as devoid of technical expressions as is possible.

ORDER YOUR COPY TODAY

25c Every Where

If your dealer cannot supply you write—

The Conrad Co., Inc.,
230 Fifth Ave.
New York

Progress in Radio

(Continued from page 60)

of the grid coil, but is joined through a resistance R. Readers will be aware, of course, that the aerial system, which consists of inductance, capacity, and resistance connected, of course, to the tuned circuit L1 C1, will materially affect it; but the inclusion of the resistance greatly reduces the effect upon the tuned circuit. By suitably adjusting the remainder of the resistance it is possible to obtain a value of feed-back coupling such that the receiver will not oscillate over the whole range of the tuning condenser. The inclusion of the resistance, however, will tend to reduce the signal strength.—*Wireless World*.

The Fly in the Ointment

(Continued from page 15)

efforts explode into large, white, digestible morsels and sometimes they lie in the pan, shriveled, seared and blah. "Don't shoot him. He is doing the best he can." Sometimes unexpected waits and gaps appear in a well-planned program and then words, wit and wisdom must bubble forth from his lips like water from dependable "Old Faithful" at Yellowstone Park—with this difference: he mustn't allow three minutes to elapse between spurts; if he did the impatient American public would be on its way, for there are no Jobs operating dials. Patience has ceased to be a virtue in this age and "Make it snappy!" is the proverb of the day. Somehow the ball must be kept in the air, or the audience will think it has tuned in on a mausoleum. So the announcer reads telegrams, translates a page from the dictionary or once more announces the names of the artists on the program, grateful when they are nice long ones!

You may be one who objects to the announcer giving the name and location of his station several times an hour, but this consumes only about five seconds. (*It has since been made compulsory by the Radio Commission.*—Editor.) In the case of a courtesy program, the name of the sponsor is always given at the beginning and end of a short program, and during intermissions in long ones; and, if telegrams boost the host, isn't it permissible to read some of those too? You may think they have nothing to do with the case, tra la, but they do.

WHY YOU ARE GIVEN ENTERTAINMENT

They are permanently bound and, the next time there seems a possibility of interesting some firm in paying the fiddler for an expensive program, this bulky volume is brought forth. When a business man sees 1644 appreciative telegrams (the number sent to KFI, congratulating them on *La Traviata*, many of them mentioning the sponsors) he is going to wrinkle his brow and rub his chin and consider this good advertising. For, be it known, the men who pay these bills are first, last and all the time, good business men—with perhaps one-half of one per cent philanthropic tendencies! If a man knows his name and product will be mentioned favorably a number of times it is worth money; but, if you deny the announcer the right to read these telegrams—well, not so good, not so good!

Many telegrams sent in represented large groups congregating in churches, clubs, hotels, halls and parks, where the program was inhaled by hundreds under one canvas. Multiply this by 1644 and it makes good reading to an advertiser!

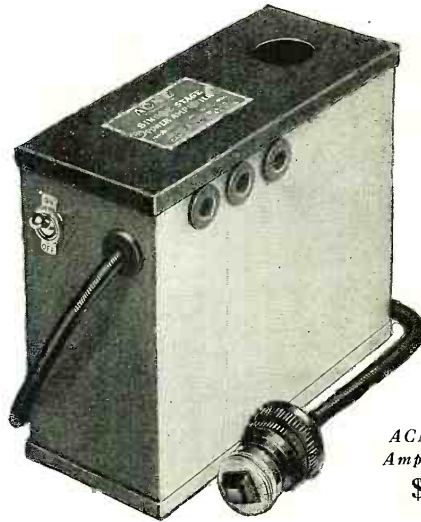

ACME Power Amplifier PA-1
\$12.50

Try this on your XYZ Set
—or what have you?

THIS spring and summer you'll be getting farther away from your speaker (out on the porch or in another room) and then you will want more volume and better quality.

No matter what set you have, its volume can be made greater and its quality improved just by adding an Acme Power Amplifier with a power tube, (171, 371, 112 or 312).

This amplifier consists of a stage of resistance coupled amplification with impedance leak, a socket, automatic C supply and transformer for lighting the power tube filament from the lamp socket.

All you have to do is connect your set, your B supply and your speaker to the amplifier, put in a power tube, plug into the lamp socket and your radio enjoyment will increase a hundred fold.

The resistance amplifier with impedance leak is the last word in audio amplification; equal ampli-

fication for all frequencies, no distortion, due to unequal amplification, or to rectification such as given with resistance leaks.

The automatic C supply insures correct C voltage on the power tube no matter whether your B supply on this tube is 90 or 180 volts. 180 recommended for 171 or 371 and 135 for 112 or 312 tubes.

If you cannot buy the PA-1 of your dealer, order of us direct, enclosing check or money order.

Send 10 cents for "Power Supply for Radio Sets"

This famous radio book, written by a prominent radio engineer, and already in its fourth edition, contains complete information on the Acme Power Amplifier and how to improve your set with it. For your copy simply send us 10 cents and coupon below and book will be mailed you at once without obligation.

ACME APPARATUS COMPANY, Dept. K-25, Cambridge, Mass.

ACME
~ for amplification

ACME APPARATUS CO.,
Dept. K-25, Cambridge, Mass.
Gentlemen: I enclose 10 cents. Please send me a copy of your new 32-page book, "Power Supply for Radio Sets."
Name
Street
City..... State.....

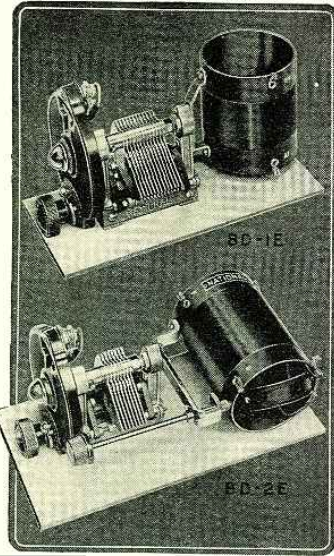

New Model Tuning Units
Employing the Official and Genuine
BROWNING-DRAKE
R.F. Transformers and Coils

WHEN you build your next set use these new units, comprising the new NATIONAL EQUI-METER Condensers, the NATIONAL ILLUMINATED VEL-VET-VERNIER DIALS and the OFFICIAL and GENUINE BROWNING-DRAKE R.F. Transformers and Coils. You will have the thrill of building with carefully engineered products of high standards, a thrill equalled only by your pleasure at its excellent and consistent performance.

Write NATIONAL CO., INC., W. A. Ready, Pres., Cambridge and Malden, Mass., for price list N-7.

See Us at the R.M.A. Show, Chicago.
Be Sure You Get the Genuine

NATIONAL TUNING UNITS

NEW TYPE
Designed and Officially Approved by
GLENN H. BROWNING

SOCKET POWER UNITS

Ask your dealer, or write us for complete information on our complete line of socket power units, chargers, Radio "A" and auto storage batteries. STEWART BATTERY COMPANY
123 N. Peoria St. Chicago, Ill.

Build a Victoreen Universal using
VICTOREEN Super Coils
Send for Folder
Geo. W. Walker Co.
6528 Carnegie Ave.
Dept. H Cleveland, O.



BETWEEN COURSES

The waits between acts of an opera are long. Various fillers have been resorted to, in order to stop the gap. Lighter musical numbers have been inserted only to bring forth groans and protests from highbrow music lovers, who say they can't stand corned beef and cabbage with their caviare and truffles. The idea of giving a brief history of the opera and composer seemed good; but the cultured listeners knew that or had it on tap in their libraries and the other fellow didn't give a whoop when, where, why or who—all he wanted was more of the same and not too much conversation. Weather, news items, and charades, all have been tried as fillers, but someone is always willing to play the conscientious objector. If Lincoln were alive and an announcer (And you have to BE alive to be an announcer!) he would say, "You can please some of the people all of the time and all of the people some of the time, but you can't please all the people all of the time over a radio."

It is only fair to say that those who criticise the big programs are in the minority, but there are just enough of them to destroy that fine edge of joy and what-a-good-boy-am-I feeling the sponsors and operators have.

BETTER AND BETTER BROADCASTS

Radio is a splendid means of elevating the musical brow of the public. The programs are interlaced chains of harmony which include all things musical. The men who plan the programs are slowly sneaking up on those whose musical tastes and opportunities have been among only the common garden varieties; and gradually leading them to the hot-house plants of rare beauty and perfume. The hope and ultimate aim is to popularize grand opera and the classics, until all ears will twitch and wave like happy puppy tails when the strains of Verdi and Wagner creep out of the radio.

Every graduate operator of a radio is a super-critic of the air. Like an insect of the ether, the true radio bug goes sniffing through the air with his little feeler; when he "contacts" with something he likes, he settles upon it with a pleasant little hum. But if it pleases him not, he is liable to plant a sting, if he is that kind of a bug. How much nicer it would be if he would remember that the sponsors and announcers are just big boys trying to get along! They are not inoculated against praise. It takes on them beautifully and they break out with brighter and better programs. They invite and welcome constructive criticism and helpful suggestions, but mere "razzing" and discourtesy never fanned a generous impulse into flame. Just be human, kindly and courteous, remembering that the announcer, like the fiddler, is doing the best he can.

And don't be the fly in the ointment!

'Round the Earth

(Continued from page 49)

than the velocity of light. Since the waves travel around the earth, their phase velocity can be estimated, and from it the group velocity. Making this very necessary correction the German observations are consistent with the height of about 65 kilometers (40 miles) which agrees very well with the height deduced from other experiments. It is advisable to point out at once that the height of several hundred kilometers for the ionized layer is the result of a false assumption.



AUDIO FREQUENCY TRANSFORMERS

Note these characteristics

High amplification ratio with flat curve.

High primary inductance maintained under normal operating conditions.

Low leakage reactance resulting in uniform amplification at high frequencies.

Every transformer subjected to ten tests to insure uniformity of product. Tested to 1000 volts throughout, therefore specially suited for use with high plate voltage.

AF-4\$ 8.50
AF-3 12.00
Output 10.00

FERRANTI, INC.

130 West 42nd Street
New York City

BOOTH
98A
R.M.A.
TRADE
SHOW
Chicago
June
13-17

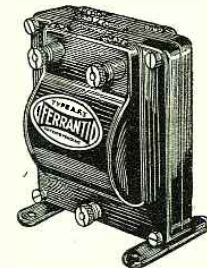

Licensed by Rider Radio Corporation.
Pat'd 5-2-'16
Pat'd 7-27-'26
and Pats Pend.

Does Your Set Oscillate?

Phasatrols

In every corner of the country, set builders and owners are improving their receivers by installing Phasatrols.

"A True Balancing Device for Radio Frequency Amplifiers"

Phasatrols stop the squeals and disturbances caused by oscillations. Don't be satisfied with ordinary reception—get Phasatrols and marvel at the results.

Write for free hook-up circular.
Price \$2.75.

At your dealers, or write
Dept. 45, 175 Varick St., New York, N.Y.

ELECTRAD

Insure your copy reaching you each month. Subscribe to Science & Invention — \$2.50 a year. Experimenter Pub. Co., 230 Fifth Ave., N. Y. C.

Light-Sensitive Crystals

(Continued from page 33)

affel rays, or a lens, or both, upon another similarly-shaped reflector or lens, in the focus of which is a selenium cell. The output of this cell may be run through an amplifier and thence to a head-set. Any sounds which actuate the microphone will cause the intensity of the light to vary accordingly and cause a corresponding change in the resistance of the cell. This experiment is best conducted with an arc as a source of light (see Fig. 4).

An interesting variation of this experiment is performed with infra-red rays instead of the usual light. These rays can be filtered very easily by means of a piece of hard rubber, about 1/8 inch thick, placed between the light and the reflector. This panel will effectually stop all visible light waves and also the ultra-violet rays (see Fig. 4A). If an arc light is used for a source of infra-red rays, care should be taken to provide sufficient ventilation to dissipate the heat generated by the light. At the receiving end the equipment is the same as that used for the light experiment outlined above. This should provide a most interesting demonstration—talking over an invisible light ray.

Although television has not as yet arrived commercially, and it may be some little time until it becomes as common as radio and the telephone, the dyed-in-the-wool experimenter wishes to familiarize himself with all the latest things that come to light in the field of science. These briefly-outlined experiments may open up a line of thought which will lead into something really worth while.

BIBLIOGRAPHY:
 "Selenium Cells," by Thomas W. Benson, *New York, 1919.*
 "Light-Sensitive Crystals," *Modern Wireless, London, April, 1927.*

He Bloops to Conquer

(Continued from page 23)

"No traffic out of the ordinary then?"
 "Passenger cars, trucks, a tractor belonging to Pete Everts, and a wagon or so," supplies the cop, displaying a keen memory for all his rustic appearance.

"What did you hear of the robbery?"
 "Well, the telephone wires had been cut, evidently just before the robbery," he decides. "They didn't get the lines repaired until after one o'clock, but we heard of it less than half an hour after it occurred. Sheriff came over in his car and told us."

"That would be about eleven-thirty," sums up The Master. "One more question: what traffic passed through Harkey between eleven and eleven-thirty?"

The constable calls over a couple of loafers, and asks them.

"Nine Fords, seven automobiles, an oil truck, and a produce wagon," informs the yokel.

The Master bows. "Thank you, gentlemen. I'll see you later."

Whereat we roll back to Brightmere. Jerry ain't saying much, though I try hard enough to pump him.

"All I have is just an idea," he states. "I can't prove a thing; we'd best drop the matter, since its solution seems beyond us."

Nothing more is found about the robbery, and two weeks later, when I drop in on The Master to spend a quiet afternoon, the episode is practically forgotten. The Master's busy on his weather control.

Newcombe-Hawley Producers Surpass!



Drum Speaker



Model 56 Console
 With Grill removed to show Reproducer.



Model 57 Console

Far in advance of any in the art of Tone Reproduction.

Compare

With any others in Tonal Qualities, Design and Profit Possibilities



Over 7-foot Exponential Air Column.

Designed in the Laboratories of Newcombe-Hawley, Inc.

Insures Perfect Reproduction.

Equipped with Matched Nathaniel Baldwin Units.

Housed in Walnut Lifetime Cabinets that match the finest furniture.

Made by the oldest exclusive Reproducer Manufacturers in the World.

A Line You Can Recommend.

Stays Sold with No Servicing.

THE TONE IS THE TEST

NEWCOMBE-HAWLEY Inc., St. Charles, Ill.

Six tubes - One Control
FRESHMAN MASTERPIECE

Sold by Authorized Freshman Dealers Only

"RADIO NEWS"

—IS A PERMANENT SHOW OF RADIO PARTS AND SETS

Every month of the year new circuits and new parts are illustrated and described. KEEP UP WITH RADIO BY SUBSCRIBING NOW

\$2.50 the Year

Experimenter Publishing Co., Inc.
 230 Fifth Avenue New York

WEBSTER

"Bone-Dri" A Socket Power and Battery Chargers

Equal to Webster "B's"—Raytheon equipped. Enough said!

Before you miss an important program from run down batteries, equip your set with Webster "A", "B" and "C" socket power. Operate from electric light socket.



Send for free booklet "How to eliminate your batteries" THE WEBSTER CO., 866 Blackhawk, Chicago

GENERAL RADIO

Parts and Accessories. Write for Catalog No. 926-N.
 General Radio Co. Cambridge, Mass.

ELIMINATE BATTERIES—BUILD A COMPLETE ALTERNATING CURRENT SET—OPERATE YOUR SET WITH LIGHT SOCKET CURRENT

**VAN HORNE
ALTERNATING CURRENT
TUBES**

Van Horne Alternating Current tubes are the invention of J. S. Van Horne. They are unlike ordinary tubes in construction and operation the filament being heated with "raw" alternating current. The filament is both the heating and the emitting element. These tubes can be used in present sets with slight changes in wiring. Diagrams showing construction of circuits arounds these tubes will be furnished.

SPECIFICATION: Filament volts 1, amperes 2. Other operating characteristics and specifications similar to standard five volt, quarter ampere tube. List Price \$4.50.

EXPERIMENTERS—AMATEURS

With these tubes you can construct a set to operate completely with light socket power, or change over your present set to alternating current operation.

DEALERS—JOBBER

These new tubes make it possible to change over present sets to complete socket power operation. Send for a set of them with instructions for their use in standard circuits. Your service department can keep busy changing over sets for owners who want complete socket power sets.

Manufactured by

THE VAN HORNE COMPANY, Inc., FRANKLIN, OHIO



Filament Control

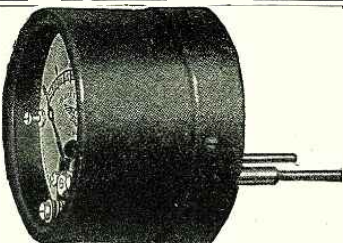

Voltmeter control of radio tube filaments—

- improves reception
- saves tubes
- preserves batteries
- gives additional radio satisfaction.

Those are several real advantages

Write for special circular No. 1015.

Jewell Electrical Instrument Co.
1650 Walnut Street, Chicago, Ill.
"27 Years Making Good Instruments"

"Nice," I declare. "When are you going to dictate to old Mother Nature how and when she's to feed us raindrops?"

"In the future," he replies, that faint smile coming up. You see, The Master's got a gag for making it rain or clear up, depending upon which kind of weather the majority desires, and I'm getting a lot of innocent enjoyment panning the article. It's a cumbersome outfit, finally requiring Jerry to build a special laboratory for it, up on the hill behind his house. We putter around for an hour or so, me being a handy man—I've got so I can listen almost intelligently when The Master explains something, which, when you consider Jerry's proclivity for elucidation, is no mean accomplishment—and helping here and there where four hands are required.

Along about two-thirty Jerry suddenly drops his tools. "I think I'll rest a moment or two," he says. "I need a little thought on this wiring diagram."

We'd been up in the storm factory on the hill, but go on down to the main laboratory. It's just as we're entering the door that the excitement lets loose.

The front door of Jerry's laboratory is right in line with the main street in Brightmere, being about thirty feet higher than the road, thus giving an excellent view. What we see is four black bearded men rush from the Second National Bank, jump into an auto, and tear out towards New York.

What gets me is Jerry's activity. For a second he stands, sort of paralyzed; then he runs into the laboratory and over to the big Tesla coil, still connected, and throws in the power, a thirty-inch spark crashing across the gap. Then, leaving the coil in operation, he yanks me out of the door, just as I'd grabbed up an army rifle that laid handy in the meantime.

The Master's pet car is being overhauled; he could have taken any one of the remaining nine, only they were in the garage, whereas his half-ton truck is standing in the driveway, all set to rear. Into this bus Jerry shoves me, and himself, grabs the wheel, and we go down the street full tilt.

We manage to keep the other car in sight, though why they don't speed up and get away from us is a mystery. The truck will do, and does fifty; after a ten-mile chase, almost to the next town, the bandit car slows down and stops. Four black beards, being coaxed by a couple shots from my rifle—I was a fair shot in the infantry, also with dice—come out of the bus, and surrender. I hold 'em at bay while The Master goes through the car, producing the money just as our local cop arrives. Jerry relinquishes his prisoners, and we roll back to Brightmere.

"How, when, where and why?" I demands, as we start toward home. "Why did they stop? They could have beat us easy."

"They had to stop," says Jerry. "They had no place to go."

"Keep it up," I command. The Master's faint smile comes in. "My hunch proved to be correct, at that" he declares. "You see, Joe, their car had a portable radio station in it, both transmitting and receiving."

"The deuce!" Jerry continues. "Their plan was as follows: they had a large covered truck, such as are ordinarily used for moving vans, and labeled it as the oil-and-grease car of a certain well-known refining company. That truck had a similar radio set. As a blind, the truck carried a few cans of grease, and the driver played the part of salesman.

"In operation, the robbers cut all telephone wires, just prior to committing the hold-up. At that time they also radioed their driver, near the filling station, to proceed there and make an ostensibly legitimate

KARAS EQUAMATIC MANUAL 10c.

MAIL 10c today for complete Manual of Karas Equamatic 5-Tube Sensation. Contains simple instructions and complete wiring diagrams for building this great receiver—the most powerful and most selective 5-tube radio frequency receiver ever designed. Address

KARAS ELECTRIC CO.,
1124 Association Bldg. Chicago



RADIO'S BEST WIRE
From the Ground Up
At All Dealers

The Kodol Radio Corp.
The World's Largest Manufacturers of
Battery Chargers and Eliminators
Cincinnati, Ohio
Watch for our 1927-28 Announcement



DURHAM METALLIZED RESISTORS

Mar-Co Dials



CONDENSERS and VERITAS RESISTORS
Stand up on their Jobs
Tebe Deutschmann Co., Cambridge, Mass.

business call; which the driver did, as the proprietor of the station told us. Having finished the call, the truck proceeded leisurely on towards Harkey. Then the black car, leaving Willomere, stopped at the filling station and started an argument, a deliberate movement to attract attention to them. The black car caught up with the empty truck in that mile east of Harkey. They dropped an incline, ran the car into the truck, and proceeded blithely on, passing through Harkey without inciting suspicion.

"The flaw in their system was the radio. Since the robbery had to be timed very closely, as well as all future movements, they depended upon radio communication in order to synchronize their actions. They figured, and correctly, that the disappearance of an automobile along that mile strip would be sufficient to ward off any further investigations until such time as they were well away from the scene. The radio was necessary, even if only to let the truck know when and where to meet them, since they could not foretell the exact moment that the crime would be committed, and a large truck could not feasibly park along that mile of road without causing comment. Clever, I call it."

"And the coil—"
—so filled the air with static that the instructions for the meeting were unintelligible to the truck driver. They had expected to meet him before they came to the next town; obviously they could not pass through it, being chased and fired upon. So they surrendered."

I grins. "Perhaps now you'll admit that static has a good use."

The Master eyes me sourly. "And so's your old man," he replies.

It's Jerry's first slang. Figure a significance to that one!

PINIS

(Copyright 1927, by Robert F. Smith)

Correspondence from Readers

(Continued from page 53)

which is quite out of their field of action—and others that additional laws be passed. It would be quite difficult, however, to settle this question by legal action; and it is exceedingly doubtful that any trade body could attempt it; particularly as much of the trouble is caused by sets and material "dumped" on the market. The set owner's best recourse is to hire service which he knows to be competent, and expect to pay for it accordingly.—EDITOR.)

A RECORD TO SHOOT AT

Editor, RADIO NEWS:

I see that you publish in your valued magazine DX records. I think that the one I have hung up has anything else out in the middle of the ocean on a raft without paddles,—and I don't mean perhaps or maybe.

On the 31st of last month at about 11:35 P. M. when I was listening to some of the west coast stations—which were coming in on the loud speaker like the well known three and a half tons of Irish confetti—my wife says to me, "Why don't you try for a little distance? I'm sick of the stations that come in like locals, besides it annoys the baby." Well, as I've been married nigh on to eleven years, I avoid all arguments whenever I can, so I juggled the dial a little and blew the dust off the crystal.

First I picked up some station, but as the announcer was talking in some foreign lingo, I couldn't tell what it was all about. They played some music that sounded like the International Tests last year; so the

This Perfect Combination has made E.C. a Criterion for Radio Tubes

- 1 Actual Tone Reproduction
- 2 Sensitivity - Phenomenal Distance
- 3 Unsurpassed Volume
- 4 Longer Life - Economy



15 Types A Need for Every Type

Quality The Standard for Every Type

Wholesalers - - Retailers

**Meet us at the Trade Show
Stevens Hotel, Chicago Ill.
June 13th to 18th**

C. E. MFG. CO., INC.
702 EDDY ST., PROVIDENCE R.I.

Largest Exclusive Tube Manufacturers in the World

WRITE FOR COMPLETE DATA SHEET

28 Leading Radio Engineers Specify Hammarlund Products In Their Newest Receivers

HAMMARLUND MANUFACTURING COMPANY
424-438 W. 33rd Street, New York

Ask us for a list of the latest models of receivers for which Hammarlund Products are officially specified.



Write for illustrated literature describing Hammarlund Precision Products for all of the popular circuits.

Insure your copy reaching you each month. Subscribe to Radio News—\$2.50 a year. Experimenter Publishing Co., 230 Fifth Ave., N. Y. C.

**Your Neighbor
Probably Owns a "Majestic-B"
Ask Him Why
Majestic "B" Current Supply**

is the best B-Unit regardless of price—it will improve your radio reception.



"B" Power at full strength
any time—and all the time.

<p>Majestic Standard-B Capacity, also 201-A tubes or equivalent: 45 milliamperes at 135 volts. \$26.50 West of Rocky Mts. \$22.00 Raytheon Tube \$4.50 extra</p>	<p>MAJESTIC SUPER-B Capacity 1 to 12 tubes, including the use of power tubes: 45 m. a. at 150 volts. AS ILLUSTRATED West of Rocky Mts. \$31.50 Raytheon Tube \$6.50 extra \$29.00</p>	<p>Majestic Master-B Positive control of all output voltage taps. For sets having high current draw or heavy biasing batteries: 60 m. a. at 150 volts. West of Rocky Mts. \$34.00 Raytheon Tube \$4.50 extra \$31.50</p>
--	---	--

GRIGSBY - GRUNOW - HINDS - CO. 4572 ARMITAGE AVE. CHICAGO-ILL.

better 9/10 said to get off that wavelength, as it gave the pup bad dreams from the groans he was letting loose. I shifted the wavelength a notch or two and then in rolled some bird reading press dispatches which he said were supplied by the West Australian Newspaper Co. through station 6WF in Perth. Says the representative of the other sex in my home, "Does that guy mean Perth Amboy across the river in Jersey? I told you to get DX!" After I had looked over my list of stations I found that 6WF was not an experimental station in Jersey, but a real, honest-to-gawd one on the other side of the footstool in Australia.

There you are. Tell these fellows for me that call a couple of thousand miles DX, that they ought to be ashamed of themselves. How I do it I don't know except that my location is rather good and the crystal is one that I picked out after trying four or five. I forgot to tell you that the volume on 6WF wasn't quite as great as when I pull in KFI, but just the same it woke up the baby.

Yours for RADIO NEWS and bigger and better DX,

M. ENDAX,
Elmhurst, L. I.

May 8, 1927.

P. S. I'm thinking of buying a tube set; do you think I would get better distance?

WRNY'S Time Chime

(Continued from page 24)

which are not used, the pick-up being entirely of an electromagnetic nature.

Thus, when the wire is struck, the physical vibrations are translated into electrical vibrations, and at once fed into WRNY'S transmitter, without going through microphones of any kind. I believe this is the first time that the sound of chimes has been transmitted electromagnetically in this manner. I might say that an ordinary bell chime could be used in the same manner, by placing an armature near the rim of the bell. I could not, however, find a bell that gave as pleasing a sound as the wire; hence the wire chime was finally selected.

The intensity of the sound of the chime can be varied by simply moving the electromagnetic pick-up nearer to or further away from the chime. The clapper that hits the "gong" is nothing but a standard relay, bought in the open market, to the armature of which a clapper is attached. The head of the clapper is semi-rigid, hard rubber. When the contact is closed, the clapper strikes the spring gong, one stroke only.

The Time Chime was built, complete, in RADIO NEWS LABORATORIES, where all research work was performed. The actual construction was done by M. J. Cutler, director of the Laboratories.

For Matchless Service and Satisfaction

Use the ACME

"A & B"

Socket Power Unit

A turn of the switch and your radio set is always ready with a strong flow of constant, dependable A & B Power

See it at the Chicago R.M.A. Show BOOTH NO. 122

It has many exclusive advantages. One switch controls everything. It's compact. It's quiet. It's always ready for action!

Comes ready to operate at **Only \$6750** East of the Rockies

COUPON

Send me your latest literature on Acme Radio Products.

Name

Address

THE ACME ELECTRIC and MANUFACTURING CO.

1412 Hamilton Avenue Cleveland, Ohio

1000 HOURS—of the Best Fun You Ever Had - -

GET YOUR COPY OF
**SAM LOYD'S
TRICKS and PUZZLES**

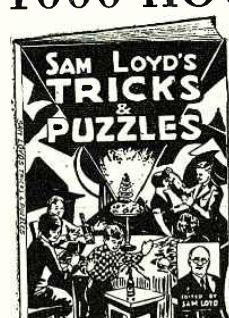

The year's most unique book—Barrels of fun, 120 pages—crammed to the full with every conceivable kind of tricks, puzzles, games, conundrums, etc.

Size 9 x 12 inches—illustrations on every page. Fun for every member of the family.

50c On All Newsstands

EXPERIMENTER PUB. CO., INC.,
230 Fifth Avenue New York, N. Y.

Set Constructors' Letters

(Continued from page 54)

RADIO NEWS on a "Double-Heterodyne Receiver," by Mr. A. Dinsdale:

"It is not a practical proposition to employ three I.F. stages, and it is somewhat better to employ only two."

I have noted a great many articles by radio engineers making similar statements. Frankly, I do not understand their reasoning. For the last three months I have used six stages of intermediate frequency, taking no particular pains in shielding or spacing the transformers, and results were beyond expectation. I am able to bring in stations one thousand and twelve hundred miles distant with a clarity equal and a volume almost equal to local stations. In fact, friends have been unable to distinguish them from local stations until the announcement was made.

The theory I have been working on, and I believe successfully, has been to get as much amplification as possible into the second detector,

thus giving the audio-frequency stages a chance to do their work properly instead of having to pull out the amplification. It would be interesting to know why the opinion is so prevalent, that more than three stages of intermediate frequency are out of the question; as I have found that more than three stages are as easy to handle and improve reception wonderfully.

Salt Lake City is one of the poorest places in the United States from a radio reception standpoint, and here difficulties have to be surmounted that do not prevail anywhere else in the intermountain country. To augment the natural difficulties, the government maintains within three miles of the center of the city a high-power radio station which causes a great deal of trouble; and a Cottrell precipitator located near us is also adding its quota of trouble.

A recently-organized Radio Listeners Club is now vigorously endeavoring to have these man-made troubles eliminated.

A. F. PALM,
(President, Radio Listeners Club)
805 Clift Building, Salt Lake City, Utah.

DOUBLE-GROUND WORK

Editor, RADIO NEWS:

I have read with interest the many articles on double ground reception appearing in recent numbers of RADIO NEWS. May I add my personal experiences?

Using a seven tube, inter-stage shielded Neutrodyne, which is very easy to couple inductively to a small, contained loop (for local stations only), by making a thorough single ground, I get DX favorable to that obtained with an outside antenna 150 ft. overall. Except on the higher wave lengths, say above 475 meters, I have never improved reception by hooking onto an outside aerial of any length, and I have four up. It is true, there is some gain in signal strength, but the static-to-signal ratio is never improved on my set by use of an aerial. Whatever stations I can bring in by use of an aerial and ground, over and above those obtainable with ground alone, are practically down to the static level, and unintelligible.

Your correspondents have either employed weak receiving sets, or have not been able to secure a real ground. I live on low land, and have soldered connections to my water pipes at the point they enter the ground, soldered connections to cast iron pipes leading to the city sewers, and soldered connections to several 12-foot pipes driven into the ground, well down below water level.

It is only fair to state that I have had poor success on daylight reception on ground only. Also longer wavelengths seem to be difficult to get. On the other hand, the set is much more selective on ground only.

It is my experience that the effort which might be expended burying an underground antenna system, might better be put into getting a single real ground. Most grounds are simply crimes! On a good set, any kind of an antenna will do, short, long, high or low, but a sure enough ground is essential to DX. I have tuned in KFI, Los Angeles, on a ground alone, and heard the call letters distinctly, and without changing the radio-frequency condensers, failed to get anything but mush and static, on a 150 ft. antenna, after careful antenna retuning.

Mr. McIntyre's strays are coming in through his underground antenna, not through his ground. His ground isn't a ground at all evidently during dry weather. I am on the ground floor of a frame building, the vertical lead to the ground being very short, but the horizontal, buried leads are rather long.

ARTHUR SMITH,
1107 Franklin Street, Tampa, Fla.

THAT GRAND AND GLORIOUS FEELING!

WHEN A GOOD MANY HOURS OF PATIENT TOIL ARE REWARDED WITH EVIDENCE THAT YOUR NEW SET DELIVERS THE GOODS!

(From The Wireless Constructor, London)

The NEW
and wonderfully improved
AERO COIL
SUPER-SENSITIVE



Perfectly
Matched

Adaptable to All
Standard Tubes

The supersensitive AERO coil has been improved! Always renowned for its selectivity, power, and sensitivity, the AERO coil is destined to win even greater favor in its new form. This new coil is the very last word in inductance coil construction. It contains a host of new and exclusive features. It possesses amazing adaptability and can be used in all R.F. circuits—both bridge and loss balanced. What's more, it is easily adaptable to 5, 6, or 7 tube sets!

Here are other sensational features of this new and improved AERO coil:

1. Rugged—Will keep appearance and original electrical characteristics indefinitely.
2. High electrical efficiency—Unusually high ratio of inductance to radio frequency resistance.
3. Shape ratio—Ratio of coil length to coil diameter is such that magnetic coupling between coils is at a minimum, thus eliminating necessity for shielding in many receivers.
4. Good mounting facilities—Terminals at lower end of coil permit short connection to tubes, sockets, etc.
5. Adaptability—Carefully designed primary windings of proper impedance for any type commercial tube immediately available.
6. Ease of connection—Screw type terminals permit optional choice of connections without soldering iron, or with soldering iron.

The new AERO coils will be shown for the first time at our exhibition in Booth 12, at the R.M.A. Trade Show. They will be available at your dealers after July 1. You can get them in 3 coil kits, with refinement, at \$12.00. 4 coil kit, with refinement, \$16. These new coils will also be used in the AERO R.F.R. Kit and the AERO 3 Circuit Tuner.

AERO PRODUCTS, Inc.

Dept. 105

1772 Wilson Ave., Chicago, Ill.



LEARN THE CODE AT HOME

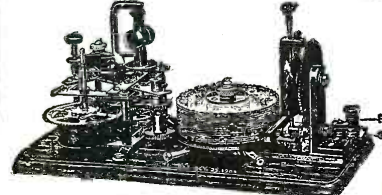

WITH THE **OMNIGRAPH**

THE OMNIGRAPH Automatic Transmitter will teach you both the Wireless and Morse Codes—right in your own home—quickly, easily and inexpensively. Connected with Buzzer, Buzzor and Phone or to Sounder, it will send you unlimited messages at any speed, from 5 to 50 words a minute.

THE OMNIGRAPH is not an experiment. For more than 15 years, it has been sold all over the world with a money back guarantee. The OMNIGRAPH is used by several Depts. of the U.S. Govt.—in fact, the Dept. of Commerce uses the OMNIGRAPH to test all applicants applying for a Radio License. The OMNIGRAPH has been successfully adopted by the leading Universities, Colleges and Radio Schools.

Send for Catalog

THE OMNIGRAPH MFG. CO.,

If you own a Radio Phone set and don't know the code—you are missing most of the fun

DO IT TODAY

15 HUDSON STREET, NEW YORK CITY

EVEREADY
Radio Batteries
they last longer

KELLOGG Radio
Flawless Reproduction

YAXLEY

APPROVED RADIO PRODUCTS



Automatic Power Control

Use the Automatic Power Control and Yaxley Radio Convenience Outlets and make this a perfect Radio summer. The Power Control automatically takes care of the switching of your set. When you turn the set on the trickle charger is cut off and the B eliminator cut in. The reverse takes place when you turn off the set. With the Convenience Outlets you can place the set on front porch and keep your batteries in the basement or any convenient out-of-the-way place.

No. 445—Automatic Power Control Multiple Type, for any set . . . \$6.00
No. 137—Convenience Outlet for Battery Connections 2.50
No. 135—For Loud Speaker 1.00
No. 136—For Aerial and Ground . . . 1.00

At your dealer's. If he cannot supply you, send his name with your order to

YAXLEY MFG. CO.

Dept. N—9 So. Clinton St.,
Chicago, Ill.

No matter what panel the specifications call for, a

RADION PANEL

will give your set the greatest protection against leaks and losses.

Order from your dealer
or write to

AMERICAN HARD RUBBER CO.
11 Mercer Street
New York, N. Y.

First Annual R. M. A. Trade Show

(Continued from page 73)

IN bringing such a large number of manufacturers together, the Radio Manufacturers' Association is performing a service of far-reaching effect. Lack of standardization from which the industry has suffered in the past, cost radio-set owners and constructors thousands of dollars a year. In this valuable work it has the co-operation of the Institute of Radio Engineers, the final authority on radio matters in the United States, and of the engineers of its member companies.

The advisability of holding a national meeting for the purpose of setting radio standards was recognized at the last convention of the Radio Manufacturers' Association, held in Atlantic City, N. J., in May, 1926. At that time it was decided to hold the Trade Show, and Chicago was selected as the best place, because of its central location.

Many new and interesting phases of standardization have been worked out and will be presented at the Hotel Stevens exhibition. Either tentative or permanent standards have already been adopted on the following: Aerials and arrestors; filament rheostats; sockets; panels; condensers and dials; power equipment, including underwriters' requirements; cords and wiring devices; plugs; jacks; switches; loud speakers; phonograph attachments; receiving sets; transformers; vacuum tubes. The lack of uniformity of the impedances of audio-frequency transformers has caused the tube manufacturers particular difficulty, and it is expected that the work in this direction, which is being carried out by the foremost engineers of the country, will bear fruit at the show.

The Radio Manufacturers' Association was formed in Chicago, in the spring of 1924, in order to give the radio industry an organization of manufacturers, who, through their co-operative efforts, could work for the benefit of radio listeners in improving of radio apparatus, and reducing the cost. The idea of founding such an association is credited to Herbert H. Frost, a prominent figure in the radio field, and was sponsored by a group of seven Chicago manufacturers. It was taken up quickly by other members of the radio business, and now the organization, which is national in scope, includes 214 members.

The R. M. A. has performed many services for the public. It was instrumental in defeating the proposed Federal tax of 10 per cent on receiving sets, and it has also killed similar proposed taxes in individual states. It has fought consistently for advantageous broadcast legislation, and has made its influence felt in Washington. It has also operated the best and largest radio shows, among which are the great annual exhibitions in New York, Chicago, and other cities.

The present officers of the Radio Manufacturers' Association are as follows:

President: A. T. HAUGH.
Executive Vice-President: L. S. BAKER,
Secretary: L. G. BALDWIN.
Treasurer: P. C. LENZ, JR.
Executive Secretary: M. F. FLANAGAN.

BRITISH PROGRESS

URBAN set owners will cheer the up-to-date methods of the city council of Hull, England, which has laid down, as a requirement for construction permits, that the architects of new buildings shall include in the plans suitable means of attaching radio aerials to the roofs.

CARTER PARTS

It's the tallest building that has to stand the most wind. So it is in Radio. It's the better products that are in the public eye. They are the most talked about, the most scrutinized. They have to stand the acid test. Because they are able to do this successfully is the reason that they are leaders.

Carter parts are the choice of the big majority. They are specified in all the popular circuits. Like the tall buildings they have a rock bottom foundation that is solid. They bear the closest inspection.

See the Carter line at Booth 95
First R.M.A. Trade Show
Stevens Hotel, Chicago
June 13th to 17th Inc.

In Canada: Carter Radio Co. Ltd., Toronto.

CARTER RADIO CO.

CHICAGO

MEMBER
R.M.A.

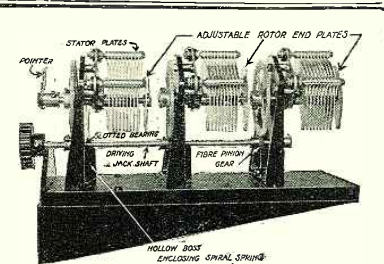

MU-RAD GROUP CONTROLLED CONDENSER UNIT

(Pretunable)

Here is a chance to get the standard Mu-Rad single control, pretunable, condenser unit, same as used in the Mu-Rad Super-Six Receivers for the past two years at an amazing price. Compensating end plates. A condenser that has stood the test of use in quantity produced receivers. Direct from factory upon receipt of purchase price, \$4.80.

Mu-Rad Radio Corporation
Asbury Park, N. J.

SANGAMO

ACCURATE - PERMANENT

MICA CONDENSERS

New, 116 Page Book

on

TELEVISION

Just Out

Complete resumé of all television experiments and information on HOW TO BUILD your own apparatus.

PRICE 50c

EXPERIMENTER PUB. CO., Inc.,
230 Fifth Ave., New York

Regeneration Control

(Continued from page 31)

In operation it is found that, when the arm of the potentiometer is thrown to one side, the set will squeal, or oscillate, when tuned to a distant station. It is then necessary only to swing the potentiometer toward the other side of the scale until the squeal ceases. The point just below oscillation is not critical, and the potentiometer arm may be swung through as much as 80° of its arc and still be just under the oscillation point. This feature makes the control easy to handle.

The regeneration control is simple to construct and apply to the detector circuit of

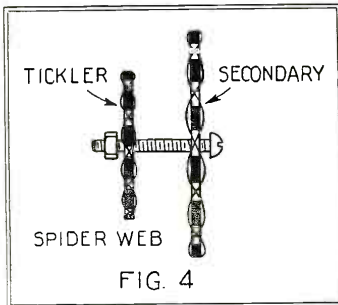

When basket-weave coils are used, the tickler and secondary are arranged as shown above.

any set not already regenerative. All that is necessary is to couple a fixed tickler coil to the last radio-frequency transformer and to shunt it with the potentiometer.

In the case of a set using common cylindrical coils, the tickler may be wound on the grid end of the coil (See Fig. 2), as described above. Where there is not room for this wire on the same form, it may be wound on a smaller tube, which is then slipped inside the form, and placed at the grid end of the secondary. (See Fig. 3).

In the case of coils of the spider-web and basket-weave types, a similar form is used to support the tickler, and placed alongside of the main coil. (See Fig. 4).

Radio Wrinkles

(Continued from page 57)

can turn out a very smooth coil by sitting in a chair, turning the coil form in his

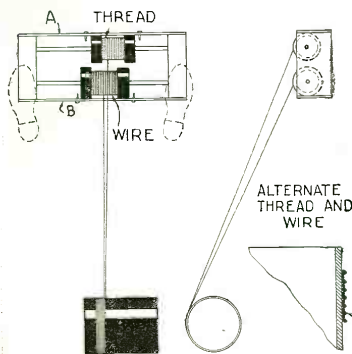

An easy method of space-winding a coil is shown above.

RAYTHEON MANUFACTURING COMPANY

MAKERS OF RELIABLE RECTIFIERS

KENDALL SQUARE BUILDING

CAMBRIDGE, MASS.

March 31, 1927

Aerovox Wireless Corporation
70 Washington Street
Brooklyn, New York

Gentlemen:

Attention of Mr. S. I. Cole

From time to time our laboratory has made careful and constructive tests on the condensers manufactured by your company for use with our type "B" rectifier in B-Power Supply Units, for use with the "BH" rectifier in B-Power Supply Units and in "A-B-C" Units using both the "BH" and "BA" 350 milliampere rectifier.

The performance of these condensers has been entirely satisfactory when used in these circuits and the actual measured capacitance has not varied from the rated value more than three percent.

The non-inductive type of construction used in your condensers is highly recommended for these circuits as our tests show filter circuits using this non-inductive type of capacitance to have greater efficiency for a given number of microfarads used.

Manufacturers of high quality B-Power Units have realized that an adequate safety factor in condenser construction is essential for continuous satisfactory service and your efforts to develop a high quality condenser will undoubtedly react to the mutual benefit of those now interested in the socket power field.

From the results of our tests we are glad to recommend your condensers to manufacturers interested in the development of quality B-Power Units.

Sincerely yours,

RAYTHEON MANUFACTURING COMPANY

AEROVOX By *D. E. Replogle*

D. E. Replogle
Sales Engineer

70 Washington Street Brooklyn, N. Y.

CABLE ADDRESS: RAYTHMANCO

FREE | New 1927 Catalog | FREE

Wholesale Headquarters.

Shows photographs and hook-ups of all latest kits, complete line of cabinets and consoles, accessories and parts. We are headquarters for all nationally advertised lines. Dealers and professional set builders write today for your copy of this big **FREE CATALOG**.

SHURE RADIO CO., 333 F-335 W. Madison St., Chicago

HIGHEST CLASS RECEIVER IN THE WORLD

Write for Information

NORDEN-HAUCK, Inc.

Engineers Philadelphia, Pa.

Merine Building.

ELKAY EQUALIZORS

specified as "ballast" for the Traveler's Set are made by The Langbein-Kaufman Radio Co. (Dept. N), 62 Franklin St., New Haven, Conn. Write for prices and tables of values.

NA-ALD

UX POWER TUBES installed in any set without rewiring by Na-Ald Adapters and Connectorals. For full information write Alden Manufacturing Co., Dept. K-30, Springfield, Mass.

PATENTS

As one of the oldest patent firms in America we give inventors at lowest consistent charge, a service noted for results, evidenced by many well known Patents of extraordinary value. Book, Patent-Sense, free.

Lacey & Lacey, 631 F St., Wash., D. C. Established 1869.

EVERYTHING IN RADIO

AT ATTRACTIVE PRICES, SETS OR PARTS. Orders shipped exactly as ordered. Prompt Service. Write for Prices. Mail Order Only. Send Your Address.

ALL RADIO COMPANY, 417 North Clark St., Chicago

Sparetime - is Yourtime

- to make every hour pay dividends in gold!

100
PAGES
or More
of
Opportunities

Illustrated

Size
9 x 12
inches



YOUR time—the few minutes or hours before and after your daily work—is opportunity land. The chance to establish a paying business or to sell your time or services to reap an additional income.

The extra income will bring within your means the luxuries of life.

It will ease your worries, your financial troubles and give you a new interest in life.

Make a start today to utilize your time. There are hundreds of ways to develop a steady, additional income that will bring to your home the many little things that make life more enjoyable.

SPARE-TIME MONEY MAKING tells you how, each issue takes various ways and means and explains them in such a way that you can immediately apply them to your own benefit. Some plans require no initial outlay, while others, for a small first cost, return many dollars a year to your pocket.

Begin now—let today be the starting point for you into a bigger income and a thorough enjoyment of the luxuries of this life.

COPIES 15c—ON ALL NEWSSTANDS.

Subscriptions \$1.50 the Year—If your newsdealer cannot supply you, use coupon below.

COPIES 15c—ON ALL NEWSSTANDS

Subscriptions \$1.50 the year

Single Copies or Subscriptions can be ordered direct

THE CONSRAD CO., Inc.

230 Fifth Avenue

New York, N. Y.

THE CONSRAD CO., Inc.,
230 Fifth Ave., N. Y.

Gentlemen—I enclose \$1.50 for one year's subscription to SPARE-TIME MONEY MAKING.

Name

Address

City, State

Order this book!

To PUZZLEDOM

—Sam Loyd's

TRICKS and PUZZLES

THERE are one thousand hours of fun and frolic—in Sam Loyd's "Tricks and Puzzles." There is only one Sam Loyd, the Puzzle King, the incomparable, a true master mind, and he has crowded in this new volume, "Tricks and Puzzles," the best work of his lifetime. In this book are thousands of puzzles, games, tricks, conundrums. Hundreds of illustrations. Scores of puzzle stories, dozens of humorous anecdotes.

With this inexhaustible gold mine of entertainment at hand you need never be at loss for an evening party program or a rainy day's delight.

It's a book for young and old folks alike—Riddles for the youngsters—Brain teasers for the grown-ups.

120 pages of puzzles, large size, 9 x 12 inches, hundreds of illustrations with beautiful colored covers.

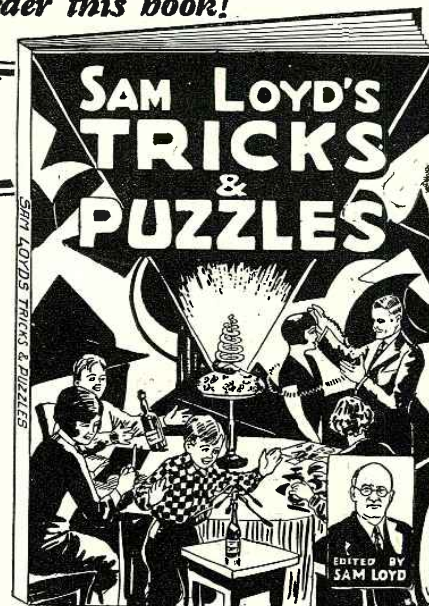

Price 50c the Copy
Sold on All Newsstands

If your dealer cannot supply you, use this coupon

EXPERIMENTER PUB. CO., Inc.

230 FIFTH AVENUE

NEW YORK CITY, N. Y.

EXPERIMENTER PUB. CO., Inc.
230 Fifth Ave., New York, N. Y.

Gentlemen—I enclose 50c for one copy of Sam Loyd's Tricks and Puzzles.

Name

Address

City..... State.....

hand, while the frame is placed on the floor (under his feet as indicated) always keeping the wire in tension to prevent making a loose coil.

—Contributed by H. W. Holdsworth.

The "Ham's Own" Short-Wave Receiver

(Continued from page 43)

upright position. All that is needed are two small L-shaped brackets, made of brass 1/16-inch thick and 1/2-inch wide. These are fastened to bolts in the variable condensers and so adjusted that they just touch the table when the panel is vertical.

The battery connections are made to the binding-post panel, which is also hung from the right variable condenser. On this are five binding posts, the mounting panel of bakelite being 2 1/2 inches square. In the centre of the front panel, near the bottom, is placed the 6-ohm rheostat, which controls the filaments of the two vacuum tubes.

Hours for DX Work

By ALBERT B. MARSHALL, 9CVR

THE following table shows the best time for amateurs to try for foreign DX. The figures following the name of each country are; first the kilocycles of the best band for this purpose; and then the hours (GMT) during which best results may be consistently obtained. The figures given in parenthesis indicate meters corresponding to the kilocycles, approximately; the U. S. range for the following is the "40-meter" ham band.

The index marks show whether traffic is restricted or not; it is forbidden in Japan.

In addition to the figures below, many countries are now working on, or vary near to 14,991 kc. (20 meters).

Country	Best Band (kc.) (meters)	Best Hours for QSO
Chile	9080-8320 (33-36)	0400-1000
Denmark	6970-6370 (43-47)	*0100-0200
England	9370-8810 (32-34) and 6810-6510 (44-46)	†2300-0800
Irish Free State	6660-3330 (45-90)	*2300-0800
Italy	8320 (36)	*0300-0500

*Experimental only.

†If not commercial or in competition with government service.

40 Non-Technical Radio Articles

every month for the beginner, the layman and those who like radio from the non-technical side.

SCIENCE & INVENTION, which can be bought at any newsstand, contains the largest and most interesting section of radio articles of any non-radio magazine in existence.

Plenty of "How To Make It" radio articles and plenty of simplified hook-ups for the layman and experimenter. The radio section of SCIENCE & INVENTION is so good that many RADIO NEWS readers buy it solely for this feature.

Radio Articles Appearing in July Science & Invention

- Vacuum Relay Operates on 1/40 Fly Power.
- Radio Traffic Signals.
- Combination Radio Set and Telephone.
- Transmission of Power over Short Wave-lengths.

Two-Tube Set for Power: Pack
By A. P. Peck



These Tubes Make Uniform Inductances

These Formica tubes threaded by a grinding process make turns of even diameter evenly spaced apart possible. They are being widely used this year by radio manufacturers all over the country. The use of single control compels evenly balanced inductances. This service is possible only on quantity orders of Tubing.

New Formica Kit Panels

The Mellow-Heald Superheterodyne and the Madison-Moore One Spot are new Formica kit panels that have been prepared for the trade. Gold decoration on gloss Black Formica.

Other Formica Panels decorated by the Veri Chrome process which are sold by leading jobbers and dealers are B. T. Power Six; Browning-Drake National; Victoreen one and two dial; H.F.L. Nine-in-Line front and sub panel; Karas Equamatic; Infradyne and others.

The Formica Insulation Company

4618 Spring Grove Avenue

Cincinnati, Ohio

Hear the FORMICA
Orchestra Tuesday
9 to 10
over WLW



Formica has a
Complete Service on
Insulating Material for
Radio Manufacturers

A Laboratory Product

CRESCENT LAVITE RESISTANCES

Used in 50 big broadcasting stations
12,000, 18,000, 30,000 and 5,000 ohms.
For distortionless amplification. Order a
Crescent today at \$1.50. Special sizes made to
order. Discounts to dealers.

Cresradio Corp., 166-32 Jamaica Ave., Jamaica, N. Y.

RADIO PANELS
OF GENUINE BAKELITE

Cut, drilled and engraved to order. Send rough sketch for estimate. Our Complete Catalog on Panels, Tubes and Rods—all of genuine Bakelite—mailed on request.

STARRETT MFG. CO.
520 S. GREEN ST. CHICAGO

C. L. PARKER
Ex-Examiner U. S. Patent Office
Attorney-at-Law and Solicitor of Patents
McGill Building, Washington, D. C.
Patent, Trade Mark and Copyright Law

Cooper "A" Eliminator
Not a Power Unit
Employs No Trickle Charger
Operates direct from the
Light Socket. See Your Dealer

HOME FURNISHINGS FREE ON CREDIT . Catalog

Over 1400 bargains in living room, dining room and bedroom furniture, rugs, dishes, etc. A year to pay. 30 days trial. Write today for free catalog.

STRAUS & SCHRAM Dept. A357 Chicago, Illinois

IMPROVE ANY SET
CARBORUNDUM STABILIZING DETECTOR UNIT. CARBORUNDUM GRID LEAKS AND RESISTORS

SEND FOR HOOK-UP BOOK.
THE CARBORUNDUM COMPANY, Niagara Falls, N. Y.



Built to fit YOUR OWN SET

Here is "B" power supply built to synchronize with your own individual set as perfectly as though you had it custom made to your own specifications. VARIABLE VOLTAGE CONTROLS give your set any voltage you need for your detector, intermediate and amplifier, plus an extra tap for power tubes.

200 VOLT
Warren "B" Supply

\$29⁷⁵

200 Volts at 20 Mils
180 Volts at 30 Mils
150 Volts at 50 Mils

Ample power for any set. Delivers unsurpassed tone quality without hum and no "motor boating." No tubes to burn out. No acids to buy or bother with—an exceedingly simple, yet highly efficient "B" power supply that costs less than \$2.00 a year to use. It will outlast your set. Will not blow out tubes on short circuit.

WARREN "B" Supply is wonderfully well made from finest materials; neat, compact; it measures only 5 1/2 x 7 x 9 inches. Metal case is finished in old gold and makes an attractive addition to any set.

If dealer does not stock
ORDER DIRECT

Biggest value ever offered. See the WARREN—hear it—compare it only with the best of others costing much more. Shipped complete, ready to plug into light socket and turn on. 110V; 60 Cycle; A.C. Approved by Radio News and other leading radio laboratories. Buy the WARREN that is built for the future as well as the present. If your dealer does not have WARREN "B" Supply send only \$29.75; we will ship prepaid. Or we can ship C.O.D. for \$29.75 plus slight express charges. West of the Rockies, \$31.25. Fully guaranteed or money back. Order now.

WARREN ELECTRIC CO.
Dept. R. N. Peoria, Ill.

Warren Electric Co., Dept. R.N.
Peoria, Illinois.

- Ship at once, express paid \$29.75 (check enclosed).
- Ship at once, C.O.D. for \$29.75, plus slight express charges.
- Send for free literature.

Name
Address State
City

DEALERS—
Design and appearance
sell it fast; performance keeps
it sold. Write for proposition.

Country	Best Band (kc.) (meters)	Best Hours for QSO
Spain	9080-6660 (33-45)	*0000-0500
Belgium	9990-6660 (30-45)	*2300-0600
So. Africa	9990-7130 (30-42)	*2200-0700
Brazil	9370-8320 (32-36)	2200-0000 0700-0900
New Zealand	9990-8100 (30-37)	+0330-1440
Australia	9370-8560 (32-35)	*800-1400
France	9370-9080 (32-33) and 5990 (50)	*2200-0600
Indo-China	9080-8560 (33-35)	*1700-2200
Japan	8560-8090 (35-37.5)	1300-1500 and 0700-1000
China	7890 (38)	1200-1400
Uruguay	8560 (35)	2200 On
Madeira	9990-7490 (30-40)	* 2200 On
Germany	7490 (40)	*0300-0700
S. India	11993-9990 (25-30)	*2300-0100

*Experimental only.

†If not commercial or in competition with government service.

NEW QRAs

5UT, H. F. PAGE, 1401 Seventh St., New Orleans, La. 39.5 m.
7HK, RADIO CLUB, Nampa High School, Nampa, Idaho. 15 w., 40-80 m.
7JL (portable), JAMES L. YOUNG (7ACN), 303 Thirteenth Ave., S., Nampa, Idaho.
8CVB (portable), CHAS. M. LALLOZ (8CDC), 605 William St., Buffalo, N. Y.
8DTI, ALEXANDER BUCHMAN, 1869 Alvaso Rd., East Cleveland, Ohio. 80 m.
N. MIYAKE, 233 Minanioribata, Tsu City, Japan, wishes an American ham correspondent.

CALLS HEARD

H. A. WHEELER, Eden Hills, South Australia, will be glad to QSL in detail to any of the following stations:

United States—1aao, 1aay, 1abz, 1aga, 1air, 1ajx, 1amd, 1aqi, 1asf, 1asu, 1aw, 1awe, 1axa, 1azb, 1azd, 1bbs, 1bnl, 1bux, 1cek, 1ch, 1cmf, 1cmp, 1cmx, 1ey, 1ka, 1mp, 1rd, 1rr, 1tz, 1vc, 1yb, 2aan, 2aco, 2afn, 2agt, 2ahm, 2amj, 2amz, 2ann, 2apv, 2asm, 2bbx, 2blm, 2bq, 2bqh, 2byg, 2ckz, 2cns, 2cuq, 2czr, 2if, 2gk, 2gv, 2ks, 2kx, 2nz, 2sq, 2tp, 2uf, 2za.

3afw, 3agl, 3aw, 3bhv, 3bva, 3bwt, 3cc, 3cdk, 3cnk, 3gp, 3lw, 3ly, 3tr, 3zo.

4az, 4bt, 4dd, 4ft, 4iv, 4js, 4ni, 4oa, 4ri, 4rm, 4rr, 4sa, 5aaq, 5ado, 5agu, 5ain, 5akn, 5ako, 5amn, 5apo, 5aq, 5aqy, 5asv, 5atf, 5au, 5auz, 5lz, 5jd, 5kc, 5kn, 5mb, 5pi, 5ql, 5rh, 5uk, 5wi, 5ww, 5wz, 5zu.

6abc, 6abg, 6acg, 6adh, 6adp, 6ahp, 6aij, 6ajl, 6ajm, 6akx, 6akp, 6ait, 6alv, 6am, 6amm, 6ann, 6ano, 6any, 6aoq, 6ary, 6asw, 6ax, 6axw, 6bay, 6bbn, 6bc, 6bcn, 6bdl, 6bel, 6bid, 6blm, 6bhr, 6bhz, 6bz, 6bia, 6bjz, 6bnw, 6bnh, 6b, 6bsm, 6buc, 6bus, 6buy, 6bvm, 6bvo, 6bvy, 6bxc, 6bxd, 6bxw, 6byz, 6lzn.

6cae, 6cco, 6ccl, 6ccu, 6cdv, 6cfn, 6chl, 6chy, 6cii, 6ck, 6cka, 6clj, 6cua, 6cud, 6cxy, 6cyu, 6cz, 6dba, 6dcq, 6dcu, 6dea, 6dh, 6fg, 6hm, 6ih, 6ix, 6jn, 6kq, 6ll, 6lq, 6lz, 6mu, 6nl, 6np, 6or, 6r, 6rj, 6rw, 6uf, 6vr, 6xp, 6yu, 6zat.

7adm, 7bh, 7ec, 7fh, 7it, 7jc, 7ju, 7mp, 7ox, 7oy, 7rl, 7tk, 7wu.

8abr, 8adg, 8adx, 8ajn, 8alf, 8ash, 8bau, 8bf, 8bgn, 8bkm, 8 bnh, 8bpl, 8bt, 8bww, 8cau, 8ccm, 8ces, 8cjm, 8ck, 8com, 8cp, 8cvq, 8dba, 8dkn, 8fr, 8gz, 8im, 8ix, 8kc, 8la, 8pl, 8wt, 8xc, 8zw.

9ack, 9aff, 9aky, 9ara, 9arn, 9atk, 9bpl, 9bpt, 9bsl, 9br, 9ca, 9caw, 9chd, 9cia, 9ck, 9ckf, 9cnt, 9esh, 9ctg, 9cvy, 9cwq, 9cxc, 9day, 9dhw, 9cd, 9dk, 9dlq, 9dng, 9dpu, 9dpw, 9dqu, 9dr, 9drd, 9dvl, 9eev, 9eev, 9eez, 9ein, 9fo, 9hp, 9kb, 9kv, 9lk, 9ln, 9nv, 9pm, 9ua, 9wk, 9xi, 9za.

2xaf, 2xg, bb3, abl, fx1, fil, dm2, npg, kel, wiz, wik, npm, kio.

MARK DOLOUKHANOFF, Paskevitcha 6, Tiflis, Caucasus, USSR. April 6-7 (230 GMT) ORK nulamd, nu2gk, nu8epf, R-3 and R-5 in Tiflis. Wishes to know QRA, type transmitters, power, etc.

GEORGE J. LITZNERMAN, 212 Central Ave., Suffolk, Virginia, U. S. A. (Heard in Buenos Aires, Argentina).

Australia, 4rb; French Indo-China, hva; Germany, agb, poz; Italy, lau.

U. S.; 1bhs, laao, 1xv, 6alr, 6bhr, 2px, 3lgr (consistently), 5aao.

BECAUSE communications from our readers exceed the available room in which to print them, RADIO NEWS can publish only "Calls Heard" in the United States and Canada from foreign countries, or vice versa; it will undertake this, as far as possible, because of its international circulation. QRAs can be published only if they are new or involve a change, so that they are not available in amateurs' call books.

MAKE THIS A RADIO SUMMER

Touring, camping, or at home, a portable Radio Receiver is a real summer enjoyment. It's convenient to carry, in your car, with your baggage, or if at home from room to room or out on the lawn.

You can build your own "portable" at a small cost—from a "Consrad" pattern which gives 4-page instruction booklet of parts needed, together with full size blueprints 16 inches wide by 20 inches high, of panel and wiring diagram.

The Consrad method is the simplest ever devised—you do not have to know anything about radio to follow it.

THIS CONSRAD PATTERN

50c—EVERYWHERE
Or send direct on receipt of 50c.

THE CONSRAD CO., Inc.
230 Fifth Ave., New York, N. Y.

BUILD YOUR OWN A & B ELIMINATOR

add power to your set and save battery expense

WE SHOW YOU HOW and furnish Complete Parts A & B ELIMINATOR KIT For Sets using up to six 1/2" ampere Tubes.....\$52.13 For Sets using more than six 1/2" ampere Tubes.....\$58.50 B-Eliminator & Power Amplifier Using 210 power tube, complete kit.....\$38.75

We Can Improve Your Receiver. Sets wired for power tubes, shielded and rebuilt. All work under the personal supervision of Mr. R. E. Lacault. Write for Estimate. Address Kit Department.

Radio Electric Laboratories
115 W. 65th St., New York
Only firm having exclusive services of Mr. R. E. Lacault, E.E.

Radio News of the Month
(Continued from page 21)

GERMAN FORTY-KILOWATTER

SOME confusion among American readers is caused by the European custom of rating stations by the input of power, instead of the output. The new "Deutschland-Sender" under construction at Zeesen, south of Berlin, which will be rated as 100-kw., will have a 40-kw. output, and supplant Koenigswusterhausen, of one-fifth the power; it will surpass Langenberg, at present the leader. It is about fourteen miles south of Berlin. Its masts will rise 690 feet above their base; as compared with 500 feet for Daventry, and 455 feet for Witzleben (Berlin) whose tower is famous for its lofty cabaret.—*Frank A. Gibson.*

The readers of RADIO NEWS are invited to co-operate by the contribution of news items which concern novelties in radio or in the uses to which it may be put; especially those in which the element of human interest is found. Government announcements or press dispatches of general circulation will not qualify; send stories of something that has happened in your own vicinity. They should be short; for each one published \$1.00 will be paid. Address News Editor, RADIO NEWS, 53 Park Place, New York City.

A LONG ANTENNA

THE new Japanese radio station at Fukuoka-mura, Saitama prefecture, which was opened for service on April 1, receives messages from America; this function was previously performed at the transmitting station, at Haranomachi, Fukushima prefecture. All the equipment of the new station is of Japanese manufacture; a special feature is the length of its single straight-line aerial, 4 ri 17 cho (10½ miles).—*T. Yamada.*

STATIONS MUST ANNOUNCE

DX FANS will thank the Radio Commission for its recent order to all broadcasters to announce their call letters and location every fifteen minutes while they are transmitting, unless a lengthy address or selection would thus be interrupted. This is for the purpose of making it easier to check up the constancy of the wave; and it is announced that a station which wobbles half a kilocycle will be called on to show cause why its license should not be revoked. At the beginning and end of each day's program the frequency also must be announced.

Station
WRNY
NEW YORK
309 Meters—970 Kilocycles
is owned and operated by the publishers of this magazine
Our Editors will talk to you several times every week—
See your Newspaper for details
TUNE IN ON WRNY

\$75.00 A WEEK BUILDING RADIO SETS —in your spare time

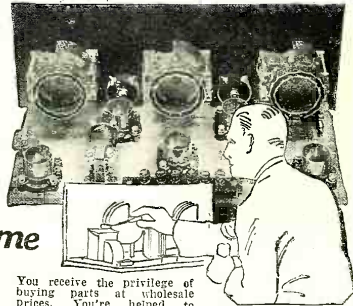

Join the Radio Association of America. Learn how to build and repair radio sets. The Association will train you—start you out in business if you wish. Be the radio "doctor" of your community. \$3 an hour upwards easily made. Radio offers you a big money-making opportunity right now.

EARNS \$500 IN SPARE HOURS

"I have at last found myself," writes Lyle Pollock, Lansing, Michigan. "I have already made over \$500 building radio sets after working hours." Werner Eichler, Rochester, N. Y., writes. "I have made over \$50 a week in my spare time."
Our members are starting radio stores, increasing their salaries, securing better positions, earning big money for the most enjoyable kind of spare-time work.

WHAT A MEMBERSHIP MEANS

A membership in the Radio Association of America enables you to get into Radio and make money from the start.
You're taught how to build and repair all kinds of sets.

You receive the privilege of buying parts at wholesale prices. You're helped to make money.

JOIN THE ASSOCIATION NOW

If you're interested in Radio for either pleasure or profit. Join the Association without delay, because we have a plan whereby your membership may not need not cost you a cent. Only a limited number of these memberships are acceptable. Write now for details. Write before it's too late.
This Association has prepared a beautiful book that gives figure-facts regarding the profit possibilities of the Radio Industry, the purpose of the Association, and the details of the Special Membership Plan.

MAIL THIS COUPON

RADIO ASSOCIATION OF AMERICA
Dept. RN-7—4513 Ravenswood Ave., Chicago.

Send me your book and details of your Special Membership Plan.

Name

Address

City

State

The Alamac Hotel
Broadway and Seventy-First Street
New York City

The perfect selection when visiting the Metropolis.

600 Rooms each with bath, shower and Servidor.

Not too large, not too small—a hostelry that offers personal service and courtesy.

Renowned CONGO ROOM & Aerial Balcony
Coolest Place in Town!

Because of location it is an ideal summer hotel.
Many garages nearby—plenty of parking space.

TARIFF MODERATE

Latz Management

WIRE AT OUR EXPENSE FOR RESERVATIONS!

DEXSTAR

Condenser Tissues

IS your Radio set giving trouble? Do the condensers have to be replaced frequently? Are you aware that this annoyance can usually be traced to the use of imperfect condenser tissue paper?

Condensers built with DEXSTAR Condenser Tissue, will give longest service and highest efficiency. ASK your dealer to ask the manufacturers, to use DEXSTAR Tissues only, as insurance against condenser break downs.

C. H. DEXTER & SONS, Inc.,
Specialists on High-Grade Condenser Tissues
Windsor Locks, Conn.

RESULTS

ONLY Amperite can give utmost life and performance from your tubes. Controls tube filament current automatically. Eliminates hard rheostats. Safeguards against tube damage and premature burn-outs. Simplifies wiring. Accept no substitute. Types for all tubes. Price \$1.00 complete. Sold everywhere. Write for FREE Hook-Ups and Construction Data to Dept. R-N. 7.

RADIALL COMPANY
50 Franklin Street, New York City

AMPERITE
The "SELF-ADJUSTING" Rheostat

10 Days Trial

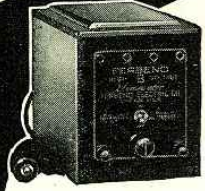

Forget "B" Battery Nuisance

FERBEND "B" Socket Power Unit Within Reach of All

Original cost less than half of any equipment of similar quality; lowest maintenance cost. Equal to any, not only in operation, but in workmanship, quality, durability and appearance. Sooner or later you will change to "B" Socket Power. Why pay more?

Model III, for all sets using 90 volts **\$12.50**

Model IV, for extremely large sets and sets using power tubes; delivers up to 180 volts, \$17.60.

ORDER NOW

Shipment made direct upon receipt of price or C. O. D., if preferred. Use for 10 days; if not satisfied, write us within that time and purchase price will be refunded. Send today.

FERBEND ELECTRIC CO. 425 W. Superior St., Chicago

ENDORSEMENT
Hartford, Conn.
"Enclosed find \$17.50 for which please ship me one of your high voltage Eliminator as advertised.
At the present time I am using your 90 volt model bought from you some time ago, but having built a new set which requires more voltage, the larger Eliminator is necessary. I am having no trouble disposing of the smaller Eliminator to one of my friends. It certainly does all you claim for it, and I will gladly recommend your products to anyone."
Herbert G. Bissell

Tested and Approved by the Rigid Laboratory Tests of Radio News and Popular Radio

Three Foot Cone OR Roll Type Speaker

MAKE YOUR OWN AND SAVE EIGHTY PER CENT OF COST WITH THE FAMOUS ENSCO KIT. ONLY \$10.00.

MAKE YOUR OWN THREE FOOT CONE OR ROLL SPEAKER IN LESS THAN AN HOUR. Complete parts furnished in kit form. We guarantee this speaker the equal of any manufactured cone speaker at any price.

With this THREE FOOT CONE SPEAKER you hear all the tones. It brings out the true depth and beauty of orchestral and instrumental music. Can be operated softly for Living Room Music or Full Volume for dancing, and without trace of distortion.

Kit includes famous "ENSCO" cone unit, the only direct-drive, distortionless unit for large cones; Alhambra Toner for big cone, with brass apex, two Sepia Prints showing cabinet or simple stand construction. All necessary instructions.

Buy this wonderful speaker under our absolute guarantee. Your money back if you are not convinced that it is the finest reproducing medium obtainable at any price. It works on any set, with ordinary Tubes or with Power Output.

----- SEND NO MONEY! -----

ENGINEERS' SERVICE CO., 25 Church St., (Desk N) New York City
Write your name plainly as indicated below, then mail and complete kit will be forwarded to you. Just pay postman \$10.00 upon delivery.

NAME

ADDRESS

STATIC

During the summer months, the most important radio problem is the elimination of static and interference. There are so many different kinds of static, however, that it is impossible for one particular device to eliminate or reduce their effects. Each form of static has its own best method of relief which is usually very simple, effective and inexpensive, and can be applied by anyone to improve broadcast reception.

Send 50c for your copy today.
Please send currency or money order only—no stamps.
MORRIS KLOSNER, B42
1000 Whitlock Ave. New York City

FREEDOM OF THE ETHER
WHATEVER the foundation for charges of "censorship" in American broadcasting, it appears to be trifling compared with that in Europe. Moscow has been broadcasting in Esperanto, and a French station, says the A.P., cuts in on the program to jam the air whenever the soviet program starts, and thus prevents its reception, at least in France. On the other hand, at a public meeting in Moscow, Comrade Zimovieff is reported to have been cut off the "mik" during a speech of party criticism. In Czechoslovakia, it is reported in the British press, three Hungarians tuned in Budapest, then transmitting a Magyar national air. The police thereupon confiscated and destroyed the loud speaker for playing forbidden music!

GROWTH OF FARM RADIO
HOW much of a necessity is radio to the progressive farmer, is being shown by the daily increase in farm-owned receiving sets. The Department of Agriculture has just announced that from 550,000 sets owned by farmers on July 1, 1925, its recent survey shows an increase to over 1,250,000 on April 1, 1927. That is to say, every fifth farm instead of every twelfth one has its radio; which, like the farm automobile, is a business asset as well as a source of pleasure. Iowa leads with 100,000 sets, or one on every other farm, practically; Indiana is second with 81,000, or two to every five farms—the number having nearly quintupled in two years. There are still five million farms to be equipped with radio, however—a huge market for the industry.

RADIO BOOTLEGGING IN CHINA
WHILE radio is forbidden by law in China, the fact that it is in use was recently evidenced by press reports of radio warnings from Shanghai to foreigners in the interior. Admiral Bullard, on his arrival recently to take up his duties on the Radio Commission, tipped off the method in a press interview.

"It is not an unusual thing in China to be approached by an individual who will say slyly, 'If you want a good radio set, I know where you can get one.' Ship operators land there," said Admiral Bullard, "with their pockets full of radio tubes, which they sell for exorbitant prices to persons ashore who assemble radio sets. One man there had 2,000 of these sets. Several department stores sell radio sets almost openly. The Chinese Army doesn't use radio but has good wire service."

RECORDS OF HETERODYNYING
ONE of Ellis Parker Butler's characters, as related in a story published some time ago in RADIO NEWS, had as a hobby collection of static on phonograph records. Not dissimilar was an exhibit made recently before the radio commissioners by a New York man who played on a phonograph a record of station interference which he had taken some time ago. Considerable amusement was created among the hearers.

RADIO IN THE CONGO
AT the recent commercial fair in Brussels, much interest was aroused in the apparatus constructed for use in the Congo; where the Belgian government has eighteen stations, by which practically all communication is effected. These are of 5-kw. power, working between 10 and 40 meters. Because of storms, and the natives' estimation of copper wire for jewelry, the maintenance of telegraph wires has been very difficult. A curious bit of psychology has been noted; savages, who distrust and fear a letter, will make use of the radio telegraph to send messages, as if they had been doing so all their lives.—L. Reid.

WHEN ~ ~ stations crowd the air & spoil your programs

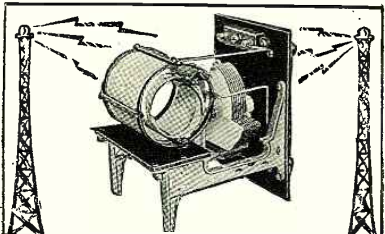

use a wave trap!

Improve your Reception—build a wave-trap with a Consrad Pattern

NO matter how large or small, how expensive or inexpensive a Radio Set may be, it can be decidedly improved with a good WAVE-TRAP.

The new Consrad pattern contains a gigantic blueprint, 27 1/4 inches by 20 1/2 inches, containing simplified Panel layout, Front View, Top View, Side View and Picture Wiring diagram. All measurements are shown actual size. A complete Illustrated Pamphlet is enclosed that shows exactly how to proceed throughout the entire construction; these are enclosed in a heavy folder envelope size 9 1/4 x 9 1/2 inches.

ONLY 25c—EVERYWHERE

If your dealer cannot supply you, write direct The Consrad Co., Inc., 230 5th Ave., N.Y.

JUST OUT!

116 PAGE BOOK ON "TELEVISION"

The first and only book on the newest and greatest science of the 20th Century that gives a complete resumé of experiments and machines developed from the earliest attempts to the apparatus in daily use.

ALSO complete instructions on how to build, at home

YOUR OWN TELEVISION SET

PRICE 50c EVERYWHERE

If your dealer cannot supply you write direct
EXPERIMENTER PUB. CO., Inc. 230 Fifth Ave. New York, N. Y.

FROM PLANE TO OFFICE

A CONVERSATION between an occupant of an airplane and the director of the Bureau of Standards, in his office at Washington, was carried on by a combination of radio and regular telephone lines on May 5; and, more than that, broadcast through station WRC. The aerial passenger was W. B. Stout, of the aircraft division of the Ford Motor Co. The experiment shows the possibility of regular long-distance communication from and to commercial planes in flight—the number of which is steadily increasing.

RADIO GETS THE JOB

NIGHT travelers on the Hudson River steamboats will be entertained by orchestras on shore this season; the navigation company has replaced its musicians with radio receivers having large amplifiers, and phonograph attachments that may fill out unmusical gaps in the programs. The saving is estimated at about \$25,000 yearly.

THIRTY-INCH WAVES

SUCCESS in experiments with 0.75-meter transmission has led the A. R. R. L. to announce a celebration of the opening of this band at the district convention in New York June 3, where a public demonstration will be made. The band contains, between 0.7477 and 0.7596 meters, just 1,000,000 cycles; as it reaches from 400,000 to 401,000 kc. (or over just as many channels as there are in the entire broadcast band) in a 4½-inch difference of wavelength.

FACSIMILE TRANSMISSION

THE beam radio system between England and the Antipodes, it is announced, will shortly be utilized for the transmission of letters, etc., in the writing of the sender, by the same process now utilized across the Atlantic, it was recently announced by Marconi. Clerical errors will thus be obviated.

AIRPLANE DISTRESS CALL

"PAN" is the new call for help to be used by broken-down airplanes; except under circumstances of pressing danger, when "SOS" will be used, according to the recent decision of the International Aviation Congress in London. The call is suggested by the French word "panne," crumpled.

ACCORDING TO J. B.

"THE U.S.A. is the only important country where 'listening' is free." Free from what? That's the important point. Minor poets, possibly—and distortion. I don't think.—*Popular Wireless*, London.

PROBLEM OF CONDUCT

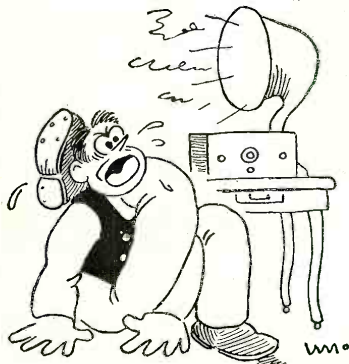

How's a fellow to disentangle himself when his receiver breaks down right in the midst of the radio exercises?



For Good Reception!

Guaranteed to remove the battery nuisance and deliver clearer tone and increased volume. Provides three different voltages at the same time. Each tap adjustable over a wide range, making possible any desired voltage from 5 to 150, absolutely harmonizing "B" current supply to your set. Raytheon tube used as rectifier. No noise or vibration. Contains no acid or solution and will not get out of order. Operating cost negligible.

At Your Dealer's

Price, Complete with Raytheon Tube - - \$35.00
Kokomo Electric Company
 Kokomo, Indiana

Kingston "B" Battery Eliminator

The SONOCHORDE CONE \$25.
Brings the Studio Home

Radio Transformers
 For All Purposes
 Thordarson Electric Mfg. Co.
 500 W. Huron Street
 Chicago, Ill. (3511)

A RADIO EDUCATION

THE RADIO EDUCATOR IN 5 VOLUMES

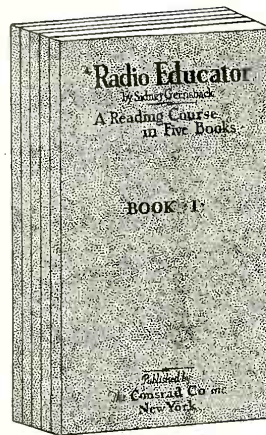

Theory, Design, Construction Operation and Maintenance

LEARN AT HOME

These five component parts of a complete Radio Instruction Course are outlined in five volumes that contain not merely the essentials as so many books do, but more, they contain all that any modern up-to-the-minute textbook on any subject would cover. They are in themselves a COMPLETE radio education teaching every possible portion of Radio science.

Size of each book 6 by 9 inches, handsomely bound and illustrated with charts, diagrams, descriptions of equipment, etc.

SEND NO MONEY

for these books. Just forward your name and address. We send you the books at once. On receipt of same you pay the postman \$1.97 plus a few cents postage and then they are yours.

PRICE \$1.97

THE CONSRAD CO., Inc. 230 Fifth Ave., New York, N. Y.

**Now
You can build the
kind of a radio you
have always wanted**



**This
BOOK
TELLS
HOW**

No matter whether you want to improve a set you now have or build a new one - get this book first. Tells how to build the latest one, two and three dial receivers - 5 to 7 tubes.

**IO & PREPAID
GEARHART-SCHLUETER, Fresno, Cal.**

**The
Famous
BALDWIN**

unit, known throughout the radio world for its fine tone quality can now be had in an exceptionally fine new speaker of the very latest type. Price, \$28.50. We've named it the—

**"99"
LOUD SPEAKER**

Can be used on any set. Write for booklet. If your dealers cannot supply you write

J. W. & W. L. WOOLF
Distributors
227-229 Fulton Street
New York

**Auto Owners
Wanted** to sell HYDRO Insured TIRES—the only tires in America Insured for One Year against all road hazards regardless of mileage. Insurance Policy with every tire. Made by the only tire factory in America selling its product through authorized Salesmen-Agents. We offer opportunity of life-time to establish profitable tire business of your own. No capital required. Sales Kit and advertising helps furnished. Exclusive territory granted. Write today for catalog and complete information about the Hydro Agency Plan.

HYDRO Insured TIRES
"The Most Beautiful Tire in America"

ADDRESS, NEAREST BRANCH, Dept. 35 HYDRO-UNITED TIRE CORPORATION
POTTSTOWN, PA. CHICAGO, ILL.

Foreign Stations

ITALY'S official radio commission, after investigation of requirements, has laid down the following program of construction for broadcast stations, in the order given:

Milan, 7 kw., now under construction; Rome, 25 kw.; Florence, 3 kw. (present Rome transmitter); Genoa, 1.5 kw. (present Milan transmitter); Trieste and Palermo, each 7 kw.; Bari, Turin and Naples, each 3 kw.; Bologna, 1.5 kw. (present Naples transmitter). After this schedule has been completed, the erection of a 25-kw. long-wave station at Milan will be considered. A convention recently established between Italy and the small independent republic of San Marino gives the kingdom the right to erect a radio station in San Marino, which is an enclave of 38 square miles in the mountains.—A. Z.

A new Parisian station, Radio-Vitus, operating on 308 meters, was opened on April 23; the new Cork (Ireland) station 6CK, 400 meters, on April 25. The former transmits between 2:00 and 3:30 a. m., E.S.T., and may perhaps be heard in the United States. Hilversum, Holland, will suspend operations on May 31, says the Department of Commerce, but a new organization is hoped for, to take the place of the former one. The Johannesburg, South Africa, station JB will be replaced by a more powerful equipment, and the present transmitter moved within the year to Bloemfontein; if arrangements being made by the African Theatre interests are carried through.

The list of Japanese stations has been enlarged by one at Keijo, JODK, 345 meters; the others are JOAK, Tokyo, 370; JOBK, Osaka, 385; JOCK 360, Nagoya; JOAK, Dairen (Manchuria) 395; all 1 kw. except the last, which is 500 watts.—N. Miyake.

A Rumanian company is to be formed to popularize broadcasting. The International Radio Broadcasting Commission at Geneva has allotted a wave-length of 236.2 meters to Bucharest.—Popular Wireless.

A Department of Commerce announcement is that Tokyo is to have a new 10-kw. transmitter, late this year, to increase JOAK's radius and subscription list. There are now 326,000 subscribers in a 100-mile radius, 80 per cent. of whom have crystal sets. In Europe, Estonia has come into the list of broadcasters with a station at Tallinn. Over 3,000 crystal sets were purchased in its district within six weeks. In Africa, the French government has authorized the Radio Club of Algiers to put up a 2-kw. broadcast station, to replace a 60-watt one with which local programs have been broadcast. There are two other radio stations in Algeria, both code.

CLEARING UP A MYSTERY

A SCHOOLBOY'S "howler" from Popular Wireless. London:

"Negative is the opposite to affirmative and is therefore positive. Batteries have both of these and are marked in algebra to show which is which and which is not, to avoid confusion."

SHAKESPEARE'S RADIO

THE Otago Radio Association, Dunedin, New Zealand, has found a Shakespearian broadcasting motto, which is printed upon its notepaper; it is taken from "The Tempest," where Caliban says:

"The Isle is full of noises,
Sounds and sweet airs that give delight and hurt not,
Sometimes a thousand twanging instruments
will hum about mine ears,
And sometimes voices."

Wonderful Bargain

at \$2.90



Redmont

Here's a beautiful cabinet at a remarkable price made possible only by our tremendous production. It is quality you can't match at twice the price.

Your Choice at \$2.90 Each

F.O.D. Hickory Cash with Order. No C. O. D.'s At this special price.

The Cabinet is made of selected hardwood with three coats of lacquer, all rubbed down to a rich, lustrous piano finish. Two nickel plated hinges.

No increased price even for larger sizes. A real bargain for the amateur set builder.

Dimension

- 7" x 18" x 10" Deep
- 7" x 21" x 10" Deep
- 7" x 24" x 10" Deep
- 7" x 26" x 10" Deep

2 hour service factory to you

Southern Toy Co. Inc.
Manufacturers Hickory N.C.

SET BUILDERS

Before you build get our special prices on the parts you are planning to use. We'll save you money. Largest and most complete stock in U. S. A.

Chicago Salvage Stock Store
Dept. RN. 509 S. State St., Chicago, Ill.

RADIO DEALERS' CATALOG---FREE!

A most complete catalog of everything in Radio. All the latest hook-ups, Sets, Parts and Kits of every description. Live Dealers need this book. Write on your business stationery.

COLUMBIA RADIO CORP.
711 W. Lake St., Dept. 243, Chicago, Ill.



TRANSFORMERS

The ultimate choice of America's leading radio engineers. Unconditionally guaranteed. Jobbers—Dealers—Write for facts.

HIGH FREQUENCY LABORATORIES
129 N. Wells St., Chicago, Ill.

HOMMEL DEALERS BENEFIT FROM OUR SERVICE AND REPAIR DEPARTMENT WHY NOT YOU?

LUDWIG HOMMEL & CO.
WHOLESALE EXCLUSIVELY
829 PENN AVENUE PITTSBURGH, PA.
Catalog 466-S is free to dealers.

Insure your copy reaching you each month. Subscribe to RADIO NEWS—\$2.50 a year. Experimenter Publishing Co., 230 Fifth Ave., N. Y. C.

Simple Loud Speaker

(Continued from page 41)

set. A neat, compact outfit is the result. The phone should be mounted on sound-proof pads.

As a final word to those who intend to convert their old phonographs for electrical operation, you will find that the available space within the cabinet is more completely utilized by the double cylinder than by a cone. A speaker of the size described is equivalent to a cone 26 inches in diameter, which would be hard to fit into most cabinets. In the case of the large models, there would be no difficulty involved in fitting a double cylinder, twice this size, into the space now occupied by the records.

Current Radio Articles

RADIO BROADCAST, May, 1927.

Under the head of "Filament Lighting from the A.C. Mains," Roland F. Beers presents much practical information on the necessary design of a set to derive its "A" current from a rectifier-tube-and-filter system; a table is included showing the most advantageous series arrangements of the tubes in different types of receivers. Advice on the use of chargers is given in "What About the 'A' Battery," by Edgar H. Felix.

Other articles are: "Perfecting the 'B' Socket-Lower Device," by Howard E. Rhodes, illustrating the waveforms corresponding to the current delivered at different points of a rectifier-and-filter system, as shown by the oscillograph, and giving constructional details; "A Balanced Short-Wave Receiver," by Frank C. Jones, describing a 30-50-meter-range set of the autodyne type, containing a Wheatstone Bridge arrangement in the aerial circuit which is guaranteed to prevent radiation; "The Electrical Phonograph," by James Millen, devoted to the phonograph and other modern pick-up and amplifier devices; "Some Facts About Coil Design," by Ross Gunn, with formulas and analysis of efficiency from various types, of which the loose basketweave is most highly recommended; "Methods of Measuring Tube Characteristics," by Keith Henney, a technical article presented to the Radio Club of America.

More general matter includes another installment of "With McMillan in the Arctic," by Austin C. Cooley, with a discussion of the effects of the aurora; and "What the Listener Likes"—there is a table of returns from 1,000 questionnaires in this issue.

RADIO, May, 1927.

"A Compact Portable Superheterodyne," by H. W. Armstrong, gives details for the building of an eight-tube set with a panel but 13½ inches long; the batteries are carried in a separate box and automatically connected by plugs and jacks to the receiver when the latter is set on top of the battery case. Warning is given that only the experienced constructor should attempt the job of building this receiver.

"Experimental Shop Methods," by Samuel G. McMen, describes the making of a galvanometer, Wheatstone Bridge, shoe electromagnet and hand-fed arc lamp for the laboratory; "Short Wave Converter," by Perry S. Graffam, covers the building of a short-wave single-tube set (regenerative detector) which may be plugged into a standard broadcast receiver to utilize the audio amplification;

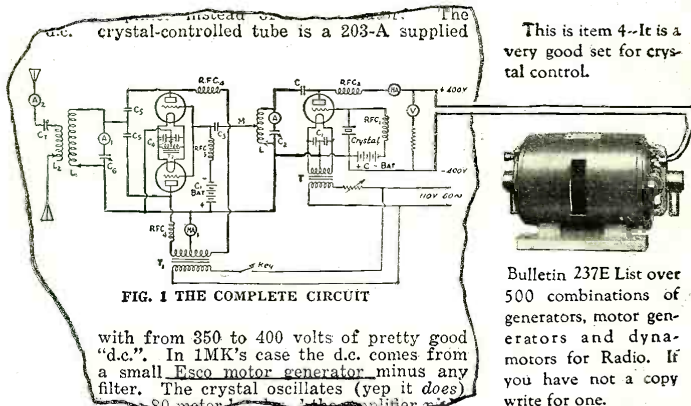
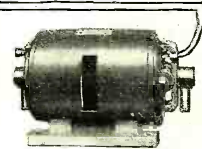

FIG. 1 THE COMPLETE CIRCUIT

with from 350 to 400 volts of pretty good "d.c.". In 1MK's case the d.c. comes from a small ESCO motor generator minus any filter. The crystal oscillates (yep it does) 80,000 cycles per second.

Clipped from March 1927 Q. S. T.

This is item 4--It is a very good set for crystal control.



Bulletin 237E List over 500 combinations of generators, motor generators and dynamotors for Radio. If you have not a copy write for one.

P.S.--Have you a copy of Filter Facts?

ELECTRIC SPECIALTY COMPANY

Mark "ESCO" Trade

211 South Street Stamford, Conn., U. S. A.
Manufacturers of Motors, Generators, Motor-Generators
Dynamotors and Rotary Converters, for Radio and Other Purposes

FRED W. STEINY
Designer of Famous
Steinite Circuits.

Steinite

LIGHT SOCKET NO-BATTERY RADIO

Don't confuse the Steinite with Power Units that operate independently and merely attach to light socket to eliminate batteries. Steinite uses no batteries—is one complete synchronized unit. Think of regular battery expense before you buy a radio.

1c An Hour To Operate

THE HIGHBOY

With Built-in Speaker

Faithfully reproduces all voices and every musical instrument with fidelity of tone. Not merely designed to eliminate battery annoyance and expense—these Steinite Models are built to use power that batteries can not supply. Hear the Tone Test and you will be convinced. Their clear reception will surprise you. Any Steinite Dealer will gladly answer every question asked about these new Steinite Models.

\$150

In One Complete Synchronized Unit

\$125 Built-in Speaker

Highly selective; coast to coast reception. All cabinets solid Philippine Mahogany, beautifully finished in dark brown shaded lacquer. Attach to any lighting circuit (60 cycle a.c. 95 to 125 v.) Use new Q.R.S. Rectifier Tube. Guaranteed against all electrical or mechanical defects. 2-dial control. Prices do not include tubes.

STEINITE LABORATORIES

Gen'l Sales Office:
306 So. Wabash, Chicago, Ill.

Largest Exclusive Radio Factory in the West.

Jobbers!

Write for Terms and Territory on these popular Steinite Models

Dealers

Write your Jobbers

Factory at Atchison, Kans.

\$100 TABLE MODEL

Use any speaker



RADIO NEWS

JULY BLUEPRINTS

You can obtain a complete set of Blueprints for these receivers direct from RADIO NEWS

A 15-1800 METER RECEIVER.....	\$1.00
Radio News Blueprint Article No. 24.	
THE ACME D-COIL RECEIVER.....	\$1.00
Radio News Blueprint Article No. 25.	
A COMPACT TRAVELER'S SET.....	\$1.25
Radio News Blueprint Article No. 26.	

Order Direct from RADIO NEWS
230 FIFTH AVENUE, NEW YORK, N. Y.

MENTION NAME OF RECEIVER AND ARTICLE NUMBER



Exclusively Licensed by Technidyne Corporation under U. S. Patent 1533658.

Remarkably Accurate!

ROYALTY VARIABLE HIGH RESISTANCES

The accuracy and dependability of these quality resistances under all conditions encountered in radio is almost uncanny.

For this reason they are the choice of leading radio experts.

- 1—Resistance element not impaired by mechanical wear.
- 2—Same resistance always obtained at same point.

A range for every purpose, designated A to 11. Type E \$2.00. All other types \$1.50.

Write for free hook-up circular.

At your dealers.

Dept. 48, 175 Varick Street
New York City

ELECTRAD

Dealers! Set Builders! Save Money!

WRITE FOR

CHI-RAD'S

Prices and Complete Information on the following Kits:

Madison-Moore—Victreen
Nine-In-Line—Meloformer
Browning-Drake—All the Best

CHICAGO RADIO APPARATUS CO.
415 S. Dearborn St., Dept. RN., Chicago

Improve reception in any circuit!

REMLER RADIO PARTS

Write for New 1927 Catalog
Banner Division of
Grave-Danielson Mfg. Co.
260 First Street - San Francisco

LIGHTING FIXTURES

Ready to Hang
Direct from the manufacturer. Completely wired, including glassware. Send for new catalogue No. 28. Just Reduced Prices. Special Proposition To Dealers.

Erie Fixture Supply Co., Inc.
Station R, Erie, Pa.

WINDSOR HORN and CONE Loudspeakers and Loudspeaker Consoles
WINDSOR FURNITURE COMPANY
1410 Carroll Avenue, Chicago, Illinois
Los Angeles Branch, 917 Maple Ave.

"A Short-Wave Super Regenerative Set," by Francis Churchill, with constructional data; and another article on a super-regenerative circuit, by G. B. Hart. A 15-watt short-wave transmitter, "The Bumblebee," is described by G. M. Best. Two technical articles are "When Interference is Necessary," by Loyd E. Hunt, a mathematical consideration of waves, modulation and detection; and "Inductance of Flat Square Loops," by C. Albert Kulmann, illustrated by graphs.

More popular articles are "The British Columbia Radiophone Service," by James Montagnes; "The Balsa Wood Loud Speaker" (constructional), by Clinton Osborne; "It Happened Off Nicaragua," a nautical story, by Earle Ennis; and "Static Facts," by Kirk B. Morcross, a humorous treatment of set owners' troubles, winding up with a serious plea for consideration of the merits of the buried antenna.

POPULAR RADIO, May, 1927.

In this issue John L. Baird, the inventor of the Televisor, tells the story of his experiments until his apparatus reached its present stage of operation with invisible rays. "Static's New Job as Life-Saver" is an account by Comm. S. C. Hooper, U.S.N., of the study of static conducted on the transport *Kittery*, and some of the resulting advances in weather-prediction methods.

The leading constructional article is "How to Eliminate Interference with the Pre-Selector," by S. Gordon Taylor, describing a two-tube unit which converts an ordinary R.F. set into a superheterodyne operating at a very high intermediate frequency; among others are "How to Build the Varion Power Pack," by Laurence M. Cockaday, covering a socket-power unit using an 85-millamp. full-wave rectifier tube; "How to Assemble the Hammerlund-Roberts Hi-Q Receiver," by Joseph Calcaterra; "Efficient and Practical Portable Sets," by William F. Crosby, containing hints for obtaining greater convenience in their transportation and operation, and "Your Laboratory Tools," the second of a series by Lowell Madden, Jr.

QST, May, 1927.

The editorial of the hams' own magazine, on behalf of the A.R.R.L., their organization, calls for a housecleaning on the 40-meter band, where it is charged that off-wave operation has been entirely too frequent; and for a vigorous assertion by more frequent use of the amateur's claim to the 150-200-meter range for telephony, which has been tentatively marked by the Radio Commission for television purposes.

Among other articles in this issue are "A Complete Inexpensive Transmitter," by Harold P. Westman, describing a complete "ham" set, which should not cost above \$45, utilizing two UX-171 tubes in a Hartley circuit; "Some Tests with R.F. Amplifiers Below 200 Meters," by Joseph Deckendorf; "The UX-852 Transmitting Tube," by Robert S. Kruse; "A Method of Grinding Quartz Plates," by Paul Mueller; "Some Convenient Relays," by Robert S. Kruse; "Successful Electrolytic Rectifiers," by S. E. Hall; "Emergency Transmitters," by Rufus P. Turner; "A Portable Antenna Tester," by A. E. Teachman; "Short-Wave Loop Receiver," by R. Preece, Jr.; and "Your Wave From a Broadcast Receiver," by Roy L. Gale. "The Air Pirate" is a story of how amateurs of Lancaster, Pa., unjustly accused of interference with broadcast reception, ran down the real offender and turned him over to the radio inspector.

WIRELESS MAGAZINE, April, 1927. London, England.

Wireless Magazine features on the front cover this month a set called the "Continental Three," which was designed by the magazine's technical staff "to show that broadcast reception with a loud speaker need not be an expensive undertaking and that a three-tube set for moderately long-range work can be built for a sum within the limits of anybody's purse." The entire outfit can be built for five pounds, or about \$25.

The circuit uses a single stage of neutralized R.F. amplification, straight detector, and a single stage of resistance-capacity-coupled audio amplification. This may seem like a rather weak combination to American radio fans accustomed to two, three and even four stages of R.F., with as many stages of A.F., but it must be remembered that Great Britain is a very small country, in which sensitive sets are not necessary for the reception of programs from the numerous existing broadcasting stations.

Other articles are: "A Home Charger for H.T. Accumulators," (the latter translated, are storage "B" batteries); "The Butterfly That Sang," a description of a crystal receiver in novel form; and "The Whys and Wherefores of Resistance-Capacity Amplifiers."

MODERN WIRELESS, April, 1927. London, England.

The editors of Modern Wireless are confident that the "Black Prince," a receiver designed by Percy W. Harris, will prove one of 1927's most popular four-tube sets in Great Britain. The feature of the circuit is a peculiar means of neutralization which involves the use of two balancing condensers and of a split-secondary tuning coil

Goodrich



Radio Panels

Black, Mahogany and Walnut.
Standard thickness 3-16" and 3/4".
High softening point prevents warping.
Low free sulphur content prevents discoloration.
Machine easier and are better electrically than any other material in common use.
Your radio dealer has them or will get them for you—if not, write to us and we will see that you are supplied.

Also hard rubber for coils, spaghetti tubing and miscellaneous rubber items for Radio Manufacturers.

Radio Sales Division

The B.F. Goodrich Rubber Company
Established 1870 • Akron, Ohio

STOP WATCHES

Needed for Accurate Laboratory Timing. The "Pastor" is a guaranteed fifth-second time-piece. Unbreakable crystal. Price only \$7.50. Start, stop, flyback hand. Or a fifth-second Timer only, 30 minute register, 6 jewel. Price only \$11.25

Write today to
Sterling Stop-Watch Co., M'n'fr.
15 East 26th St. New York, N. Y.

116 - pages of MODERN MAGIC

by **Dunninger**



The greatest living magician of today

Tricks by the thousands

"POPULAR MAGIC" SECOND PRINTING

First completely sold out

EVERYBODY'S buying this book. The first time "Dunninger" has revealed his tremendous store of marvelous parlor and professional tricks and magic in one volume. Second big edition of 100 pages, crammed full of mystery. Illustrated—large size 9 x 12 inches.

They are going faster and faster. Orders are pouring in. We believe there never was a magic book like this. It may never be reprinted—so order now. Delivery within 24 hours.

THERE'S NOVELTIES—FUN—MYSTERY IN "POPULAR MAGIC"

ONLY 50c

If your dealer cannot supply you, order direct
EXPERIMENTER PUB. CO., Inc.
230 Fifth Ave. New York

90 Vol Power Unit :: \$12.75

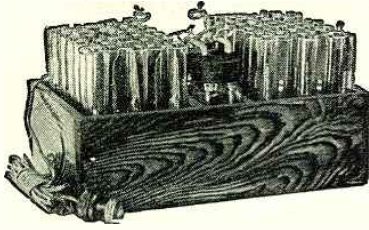

Hums, line noises, etc., positively impossible with this new advanced unit. Plug in and forget Non-acid and noiseless. All detector and intermediate voltages plainly marked. Simpler to hook up than dry cells. Operates any type set 1 to 12 tubes.

Greater volume and clearness guaranteed. If not thoroughly satisfied return after using 30 days for complete refund. Guaranteed further 2 years. For 110-120 volts A.C. 25 to 60 cycle current. 90 volts, \$12.75; 112½, \$15.25; 135, \$17.50; 157½, \$19.50; 180, \$24.00; 202½, \$26.00.

Also built for D.C. current 110 and 32 volts at only \$3.00 additional, any size above. Ample stocks—same day shipments. Simply say—ship C.O.D. or write for my interesting literature, testimonials, etc.

B. HAWLEY SMITH

334 Washington Ave., Danbury, Conn., U.S.A.



Write for This Wonderful offer direct from factory

World's greatest radio. Perfect working, single dial control, 7-tube receiver, shipped to your home for 30 days free trial. Test it for distance, volume and tonal quality—and if you are not convinced that it is the best single dial set you ever heard return it to factory.

Retail Price \$75 Completely Assembled

METRODYNE SUPER-SEVEN

Only one dial tunes in all stations. Get 1,000 to 3,000 miles on loud speaker. Easiest set to operate. Highest grade parts used. Magnificent Two-tone Walnut Cabinet.

Big Profits to Agents and Dealers selling Metrodyne radios. All or part time. Great money making opportunity. Demonstrating set on 30 days free trial. WRITE FOR OUR OFFER.

METRO ELECTRIC CO.

2161 N. California Ave., Dept. 10A, Chicago, Ill.

BUILD YOUR OWN GRANDFATHER'S CLOCK



—and then build them for your friends and neighbors—Everyone wants one—fine profits, no competition. We furnish blue prints and finishing material, works, dial, pendulum, weights, etc.

Plain works as low as \$5.00, others with chimes at a range of prices to suit every customer.

Ask for Attractive Free Offer AMERICAN CHIME CLOCK COMPANY

1681 Ruffner St., Philadelphia, Pa.



SET BUILDERS — DEALERS Get this Bargain Sheet It enables you to buy high grade, nationally advertised kits, transformers, condensers, and parts at less than factory cost. Most prices are equal to sell you C. O. D. direct by mail ONLY—no references required. HENRY WEBER 6742 N. Maplewood Ave., Chicago, Ill.

WHOLESALE EXCLUSIVELY
LUDWIG HOMMEL & CO
929 PENN AVENUE PITTSBURGH, PA.
SATISFIED DEALERS BECAUSE WE HELP THEM
Catalog 466-S is free to Dealers

aims and achievements of the British Broadcasting Corporation, "B.B.C." engineering in 1926, the wireless "aunts" and "uncles" (so dear to the hearts of the British listening public), television (an account of John L. Baird's work), how to buy a "wireless" (radio) set; women and "wireless" and "wireless" in the hospitals. The technical portion deals with insulation and insulating materials, amateur radio in 1926, the problem of the oscillating crystal, radio and the cables, recent developments in "wireless," round the factories and a list of radio societies.

Although the general contents of the Year Book are excellently prepared and edited, we suspect the editor is somewhat insincere in his comment on the British Broadcasting Company, and its standing. He writes in the preface: "As foreshadowed in the preface to the 1926 edition of the Year Book, the British Broadcasting Company has now been taken over by the Government and will in future be administered by a body known as the British Broadcasting Corporation. We are glad to learn that the Executive will remain substantially the same as before—because we believe that the staff which has built up the broadcasting service to its present high standard is the one best fitted to maintain and improve the service."

Perhaps the editor of the Year Book does not listen in, or else he is trying to whitewash a black situation; for in the denunciatory articles we have read in British radio magazines we find the general agreement that the government-controlled B.B.C. is proving a failure from the broadcast-program standpoint, and that considerable improvement could be made in its methods of operation. Aside from this, the book is an attractive little volume, which American radio fans can read with much interest.

RADIO GUIDE OF 1927, published by Amalgamated Wireless, Ltd., Sydney, Australia. 7x9½, 176 pages, paper covers, illustrated. Price one shilling.

This year book is similar in appearance and make-up to that published by Sir Isaac Pitman & Sons, of London, but is devoted to only the radio activities of Australasia. It is divided into five sections: radio activities; receivers; accessories; technical and service articles; call signs and licenses.

The first describes the advances in trans-oceanic communication and tells about the direct radio service between Australia and England, the outstanding broadcasting transmissions of 1926, the use of radio in the gold fields of New Guinea, record long-distance short-wave communication, ocean newspapers, radio in "outback" Australia and police radio.

In the second and third sections complete descriptions are given of nine receivers and of numerous accessories and parts. The technical articles contain advice on the construction, installation and care of various kinds of sets, the use of radio formulas, circuit symbols, the international Morse code, and time charts.

Just as the Pitman Year Book is a reflection of radio in England, the Radio Guide is a mirror of affairs at the Antipodes. Radio men who like to keep abreast of international development in the general field of radio should add a copy to their bookshelves.



[PALMISTRY]

A Revelation of Character, Fortune and Natural Span of Life.

FINGERPRINTS are used throughout the world as a means of apprehending criminals—but fingerprints are but a small portion of the secrets of your character that your fingers, your palm, even your hand-shake reveals.

Every inch of your hand has been charted by the experts of this highly developed science, and so simply and accurately that anyone can learn the telltale signs by heart.

Here is a brand new book with all the latest information—written in such a way that you can quickly master "Palmistry."

Price 50¢

IT'S BRAND NEW

96 Page Book

Hundreds of illustrations

Size 9 x 12 inches

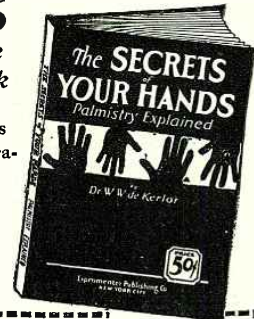

EXPERIMENTER PUB. CO., Inc. 230 Fifth Avenue, New York, N. Y. Gentlemen—I enclose 50c for one copy of "SECRETS OF YOUR HANDS."

Name
Address
City, State

AMAZING STORIES IN OUR JULY ISSUE

THE ETHER SHIP OF OLTOR, by S. Maxwell Coder, the first honorable-mention cover contest story, which deals with Venus and a war there.

THE VOICE FROM THE INNER WORLD, by A. Hyatt Verrill.

THE LOST CONTINENT, by Cecil B. White, third honorable mention. Some thoughts on the fourth-dimension and a trip centuries back in time are very cleverly worked in.

THE GRAVITOMOBILE, by D. B. McRae, fourth honorable mention, treats the subject of the illustration in a quite individual manner. It starts in Mexico, goes to Mars, and ends—well, very unexpectedly.

THE MOON POOL, by A. Merritt (Conclusion). The third and final instalment carries you into the realms of the mysterious Three and the Shining One.

RADIO MATES, by Benjamin Witwer. A fascinating romance around the possibilities of sending solids, and then living beings, through the air to be "received" at distant points.

THE PLATTNER STORY, by H. G. Wells, probably constitutes the forerunner of all his other stories dealing with a fourth, or higher plane.

OPPORTUNITY AD-LETS

Follow these advertisements every month. Reliable advertisers from all over the country offer their most attractive specials in these columns.

Classified advertising rate twenty-two cents a word for each insertion. Ten per cent discount for 6 issues, 20 per cent discount for 12 issues. Name and address must be included at the above rate. Cash should accompany all classified advertisements unless placed by an accredited advertising agency. No advertisement for less than 10 words accepted.

Objectional or misleading advertisements not accepted. Advertisements for the September issue must reach us not later than July 1st.

CIRCULATION LARGER THAN THAT OF ANY OTHER RADIO PUBLICATION

EXPERIMENTER PUBLISHING CO., INC., 230 Fifth Avenue, New York, N. Y.

Agents Wanted

Big Money and fast sales. Every owner buys gold medals for his auto. You charge \$1.50; make \$1.35. Ten orders daily easy. Write for particulars and free samples. American Monogram Co., Dept. 133, East Orange, N. J.

Guaranteed Genuine Gold Leaf Letters anyone can put on store windows. Large profits, enormous demand. Free samples. Metallic Letter Co., 422 N. Clark, Chicago.

Business Opportunities

Free Book. Start little Mail Order Business. Pier Company, 724 P. Cortland Street, N. Y.

Radio Fans! Turn your spare time into cash! Big money making plan! Particulars FREE! Star Crystal Co., 99 Jleecker St., Brooklyn, N. Y.

Amateur Cartoonists: Make money in spare time with new cartoon selling plan. Smith's Art Service, Wenatchee, Wash.

Earn \$120 to \$250 Monthly: expenses paid as railroad traffic inspector. We secure position for you after completion of 3 months' home study course or money refunded. Excellent opportunities. Write for free booklet. G-30, Standard Business Training Inst., Buffalo, N. Y.

Co-operative membership in EIA RADIO is establishing one honest, industrious man of each locality in his own successful radio industry. Young married men preferred. Write, naming your county. Eminent Indus. Workers Association, Radio Division, 350-R Broadway, New York.

Chemistry

Learn Chemistry at Home. Dr. T. O'Connor Sloane, noted educator and scientific authority, will teach you. Our home study correspondence course fits you to take a position as chemist. See our full page ad on page 71 of this issue. Chemical Institute of New York, 66R-W, Broadway, New York City.

Correspondence Courses

Used correspondence school courses sold on repurchase basis. Also rental and exchanged. Money-back guarantee. Catalog free. (Courses bought). Lake Mountain, Pistah, Alabama.

For Inventors

I am in touch with hundreds of moneyed men and manufacturers who wish to buy good inventions. Hartley, 38 Court St., Bangor, Maine.

Help Wanted

Earn \$25 weekly, spare time, writing for newspapers, magazines. Experience unnecessary. Details FREE. Press Syndicate, 978, St. Louis, Mo.

Detectives Needed Everywhere. Travel. Experience unnecessary. Particulars free. Write, American Detective System, 2190 Broadway, N. Y.

Y. M. C. A. Radio Institute, 154 East 86th Street, New York. Hundreds of successful graduates. Home Study and School courses. Radio operating or mechanics. Write for Free Booklet.

Men, get Forest Ranger job; \$125-\$200 month and home furnished; permanent; hunt, fish, trap. For details, write Norton, 270 McClann Bldg., Denver, Colo.

Instruction

Build Your Own Broadcasting Set. Very simple and inexpensive. Instructions for \$1.00. Walter Schultz, Kenesaw, Nebr.

Miscellaneous

Inventors: Use our special service for presenting your invention or patent to manufacturers. Adam Fisher Mfg. Co., 272-A Enright, St. Louis, Mo.

Wanted: Men who want to make money to co-operate with a National Radio Service Organization. No limit to earnings. No selling. Co-operative Radio Doctors, 131 Essex St., Salem, Mass.

Forms to Cast Lead Soldiers, Indians, Marines, Trappers, Animals, 151 kinds. Send 10c for illustrated Catalogue. H. C. Schlercke, 1034 72nd St., Brooklyn, N. Y.

Motorcycles, Bicycles

Don't Buy a Bicycle Motor Attachment until you get our catalog and prices. Shaw Mfg. Co., Dept. 6, Galeburg, Kansas.

Old Money Wanted

\$2 to \$500 each paid for hundreds of Old or Odd Coins. Keep all old money. It may be very valuable. Send 10c for New Illustrated Coin Value Book, 48c. Guaranteed prices. Get posted. We Pay Cash. Clarke Coin Company, 14 Street, LeRoy, N. Y.

Patent Attorneys

Patents—Send for form "Evidence of Conception" to be signed and witnessed. Form, fee schedule, information free. Lancaster and Alvine, Registered Patent Attorneys in United States and Canada, 269 Ouray Bldg., Washington, D. C.

Patents. Send drawing or model of your invention for examination and instructions. Advice and booklet free. Highest references. Best results. Promptness assured. Watson E. Coleman, Patent Lawyer, 724 9th Street, N.W., Washington, D. C.

Inventors—Should write for our Guide Book, "How to Obtain a Patent" and Record of Invention Blank, sent free. Send model or sketch of inventions for our Inspection and Instructions. Free. Radio, Electrical, Chemical, Mechanical and Trademark Experts. Terms Reasonable. Victor J. Evans & Co., 922 Ninth, Washington, D. C.

Patents

Inventions Commercialized. Patented or unpatented. Write Adam Fisher Mfg. Co., 278 Enright, St. Louis, Mo.

Patent Sense—Valuable book free. See Lacey's ad page 85—Lacey & Lacey, 631 F. St., N.W., Washington, D. C. Established 1869.

Patents for Sale

Valuable patent for sale. Children's playground equipment. Roland Zollner, Berwick, Penna.

Printing Outfits and Supplies

Print your own cards, stationery, circulars, paper, etc. Complete outfits \$8.85; Job Presses \$11, \$29; Rotary \$149. Print for others, big profit. All easy, rules sent. Write for catalog presses, type paper, etc. Kelsey Company, P-15, Meriden, Conn.

Multigraph typewritten letters sell anything. Two dollars thousand. Miscellaneous printing. Mayer Rey Corporation, Monmouth, N. J.

Radio

Boys! Don't Overlook This. The "Rasco" Baby Detector. Greatest detector ever brought out with moulded base. Fully adjustable. See former advertisements in this publication, or our catalog. Detector with Galena Crystal, complete \$6c, the same detector with Radiocite Crystal, 75c pre-paid. Send for yours today. Radio Specialty Company, 86-98 Park Place, New York City.

Attention!—50 vacuum tube hook-ups. The greatest collection of vacuum tube circuits ever brought under two covers at such insignificant cost. These diagrams will be found in the great "Rasco" catalog, which contains raw materials and parts in a greater profusion than any other catalog. Send for free catalog. Radio Specialty Co., 96-98 Park Place, New York.

Burned Out Audio Transformers Repaired. \$1.50. A. W. Cooper, 1915 W. 39th St., Los Angeles, Calif.

Own a Broadcasting Transmitter or Amateur Code Set at LOW PRICES. BARGAINS on Short Wave Tuners. Repairs made on Audio-Radio-Power Transformers, Headsets, Speakers. All work guaranteed. S & S RADIO CO., 61 N. Warren St., Trenton, N. J.

30H, 85 M.A., 280 Ohm chokes, \$2.75. We estimate on Kits to your specifications. Radio Parts Sales Co., Orange, N. J.

Gang Condensers—Standard factory inspected Mu Rad group control units same as used in Mu Rad Receivers. See page 82. MURAD RADIO CORPORATION, Ashbury Park, N. J.

Salesmen Wanted

Salesmen—Get exclusive selling rights of a scientific disease health product needed in every home. Unlimited possibilities. Write Cadmusized Application Co., 1903 Fillmore, Buffalo, N. Y.

Scenery for Rent

World's Most Beautiful Settings for operas, plays, minirels. Amelia Crain, Philadelphia.

Song Poems

Song Poem Writers—Address Hibbeler, Dix, 2104 N. Keystone Ave., Chicago.

Song Writers

Song-Poem writers. Monarch, 236 W. 55th St., New York.

Songs: We will compose melody to your song-poem for your approval. Send no money. Send poems immediately. National Song Bureau, 1074 Broadway, New York City.

Telegraphy

Telegraphy—Both Morse and Wireless taught thoroughly. Big salaries. Wonderful opportunities. Expenses low. chance to earn part. School established fifty years. Catalog free. Dodge's Institute, Cour St., Valparaiso, Ind.

Wanted to Buy

Full Value Paid for Old Gold, Jewelry, Watches, Diamonds, crowns, bridges, dental gold, silver, platinum, gold or silver ore; magnetite, old false teeth. Packages returned if offer is not satisfactory. United States Smelting Works (The Old Reliable) 39 So. State St., Dept. 15, Chicago, Ill.

LYNCH METALLIZED WARRANTED FIXED RESISTORS HEAVY-DUTY-TYPE

The new Lynch wire-wound heavy duty resistors for eliminator and power work are now ready. These units are ideal for use in Raytheon and all other power circuits.

EQUALIZORS

For perfect filament control use the Lynch Equalizers. There is a type for every type of tube and for any combination of tubes. A Lynch Equalizer will take the place of your filament rheostats. Complete, with mounting, \$1.00.

Lynch Suppressors and Low-loss mountings mean better radio.

At All Good Dealers

ARTHUR H. LYNCH, INC.  General Motors Bldg., 1775 E. Way, at 57th St., New York, N. Y.



HOTEL GIBSON

RALPH HITZ, Manager

Largest hotel—1,000 Rooms
Thoroughly modern
Florentine Room
unequaled anywhere
for beauty
Famous for food
Moderate prices
Coffee Shop

CINCINNATI

Royal Hospitality in the Queen City

Special Library of Information
on
RADIO PATENTS
and
TRADE MARKS

JOHN B. BRADY
Patent Lawyer
Ouray Building Washington, D. C.

Cable address: RADIOPAT Telephone: Main 4806

Insure your copy reaching you each month. Subscriber to RADIO NEWS—\$2.50 a year. Experimenter Publishing Co., 230 Fifth Ave., N. Y. C.

READY

Summer Edition  Fifty Cents

Radio Listeners' Guide and Call Book

Edited by S. Gernsback

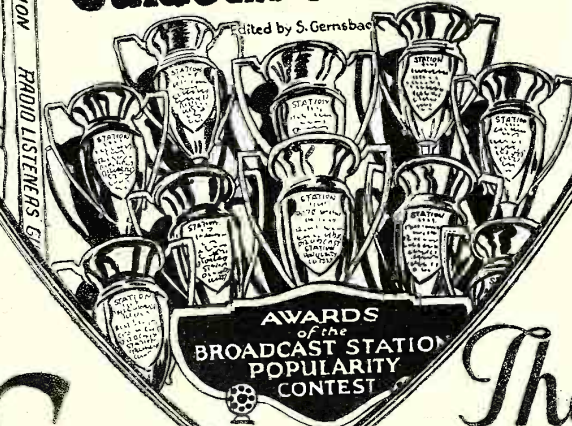

The new Summer-EDITION

SUMMER is here—with the big outdoor features on your radio —baseball, fights, stadium and band concerts.

You'll want all you can get of course. But to get them all you'll need a brand new up-to-date call book.

The new "Summer Edition" of Radio Listeners Guide and Call Book is as new as the season. Bright and fresh from the press.

It gives the very latest revised list of all broadcast stations of the United States, Canada and foreign stations. Arranged with spaces for writing in your dial readings.

And don't forget—there are a dozen or more brand new circuits written up for home construction. See the list of contents on this page.

It's one great edition for each and every radio set user. Contains 176 pages, 100 illustrations on the large magazine size, 9 x 12 inches—and with a beautiful two-color cover.

Buy your copy today

50¢
the Copy

ON SALE EVERYWHERE

50c THE COPY

If your dealer cannot supply you, order direct
The Consrad Co., Inc. 230 Fifth Avenue, New York

50¢
the Copy



—for every set owner or set user



LIST OF CONTENTS

	Page
Radio Broadcast Stations of the U.S. by Call Letters...	17
Radio Broadcast Stations of the U.S. by Wavelengths...	41
Radio Broadcast Stations of the U.S. by States and Cities	49
Radio Broadcast Stations of Canada by Call Letters ...	57
Radio Broadcast Stations of Canada by Provinces and Cities	61
Foreign Broadcast Stations, including U.S. Possessions...	63
Cup Winners 1927 Broadcast Station Popularity Contest 74	
Prizes Awarded in Radio Set Contest 76	
How to Build the Transoceanic "New Phantom" Model. 79	
How to Build Sir Oliver Lodge's "N" Circuit Receiver...85	
The Phasatrol Receiver	90



for Set builders, Amateurs and Engineers



LIST OF CONTENTS

	Page
The Phono-Radio Combination Set...	95
The Keystone Five-Tube T.R.F. Set	100
How to Build the S-C II	104
How to Build the Standard Browning-Drake Receiver	109
Building the Lof-tin-White Constant-Coupling Receiver	115
A 13 to 735 Meter Universal Receiver	121
A Constant Voltage "B" Eliminator	123
How to Install Power Tubes	125
Some Interesting Experiments with Large Cone Reproducers	127
When You Take Your Radio Vacationing	132
The Listeners' Accessory Guide...	134



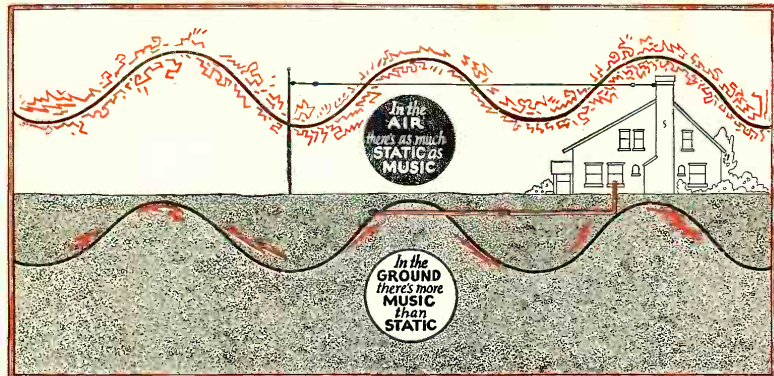

Use **STATIC-FREE** Ground Waves Get Distance Loud and Clear all Summer

SUBANTENNA—new underground Antenna System astounds listeners and laboratories with loud clear DX on hot summer nights when old style aerial gets nothing but unwanted noise

Imagine the intense pleasure of bringing in your favorite distant station loud and crystal clear—right through summer's curtain of static and noise! But, you don't have to be content with merely imagining it. Real DX in summertime—real big volume—amazing clarity—much better selectivity—all these are now available to you—and, with your present set. Simply connect your set to SUBANTENNA—the marvelous new underground antenna system that uses filtered ground waves instead of noisy air waves.

Read PROOF that SUBANTENNA is the Greatest New Thing in Radio

Says Static Is No More

"I have received the Subantenna. My grandson installed it. STATIC IS NO MORE. Am well satisfied. I can tune in stations I never could coax out of the air even though I had a long aerial."—A. E. F., Kans.

"Better Selectivity—No Static"

"It has always been impossible for me to eliminate the Drake Hotel. I was told that Subantenna would enable me to do this. Although skeptical, in view of many similar claims made by other manufacturers of radio accessories, I had one of the Subantennas installed. The results have been most satisfactory, in that I have not only been able

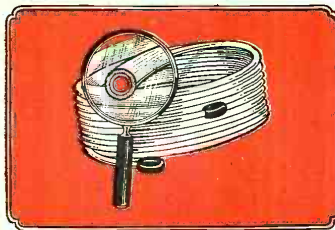

to get every station in Chicago of any consequence, when the Drake was on the air, but out-of-town stations as well. In addition I am able to report that static, which was a source of much annoyance before, has been entirely eliminated so far as I am able to observe."—R. L. P., Chicago.

Michigan Gets California

"I have had KFI, California, several times and go all over U. S. A. to Portland, Maine. You have the goods. It is far better for volume and tone on loud speaker than outside aerial."—C. J. S., Mich.

Why SUBANTENNA Makes Every Night a Good Radio Night

In summer air, the ratio of static strength to signal strength favors static. The "noise" is so much greater

than the broadcast signal that it hides the music you wish to hear. That's why you don't get distance in the summertime. But, when you use SUBANTENNA, the situation is just reversed. For, in the ground, the ratio of static strength to signal strength favors the latter. In fact, there is so little static in the ground that the broadcast signal easily dominates it, with the result that you hardly hear the static, even on the most distant stations. Radio research men have long known this fact, but no device had ever been perfected by which ground waves could be used. Now, however, you have SUBANTENNA—a great new device which makes radio, for the first time, an all year 'round pleasure.

Eliminates Lightning Risk

Not only will SUBANTENNA give you loud, clear DX in summer—not only will this remarkable invention better the selectivity of your set—but it also completely eliminates the lightning hazard. With SUBANTENNA you can go right on listening-in during the most severe electrical storm without noise, fear of attracting lightning or damaging your set.

FREE TRIAL

Make This Convincing Test

Install SUBANTENNA. Leave your old aerial up. Select a bad night when DX is almost impossible with the ordinary aerial. Make a comparison station for station, connecting first your aerial, then SUBANTENNA. If, from stations that are just a mess of jumbled noise with the old aerial, you don't get reception that rivals local in sweetness and clarity the instant you switch to SUBANTENNA, this test won't cost you even a single penny. Send coupon at once for scientific explanation of SUBANTENNA and for particulars of GUARANTEE and FREE TRIAL OFFER. Send COUPON NOW!

SUBANTENNA

Underground Antenna System

CLOVERLEAF MANUFACTURING CO.

2715L CANAL STREET

CHICAGO, ILLINOIS

CLIP AND MAIL AT ONCE

CLOVERLEAF MFG. CO.,
2715L Canal Street, Chicago, Illinois
Tell me all about SUBANTENNA, your unequalled, unconditional guarantee and your FREE TRIAL OFFER.

Name

Address

SM

The Penalty of Leadership



The S-M 660 Unipac kit is the most powerful receiving amplifier available, together with a self contained A, B and C power supply. Using two 171 tubes, the undistorted power output of the new push-pull power amplifier stage is greater than that of a 210 tube with 400 volts, while with a pair of 112 tubes it is practically equal to a 210 power pack. The Unipac also furnishes practically constant B voltage for receiver operation—10 milliamperes at 45 volts and up to 45 milliamperes at 90 volt—ample for the largest sets.

Used with any standard receiver, the Unipac will provide a stage of power amplification of surprisingly perfect quality, thus serving to modernize last year's set and will eliminate B batteries as well. It operates from any 60 cycle, 105 to 120 volt home light socket.

The 660 kit contains all parts for assembling the push-pull power amplifier, ABC power, and receiver B supply, with steel cabinet and chassis. Price, \$62.00.

Type 660-B, a slightly lower powered unit, superior to any standard 171 power pack, contains a regular one stage power amplifier of 220 and 221 transformers for a 171 tube, and is priced at \$47.

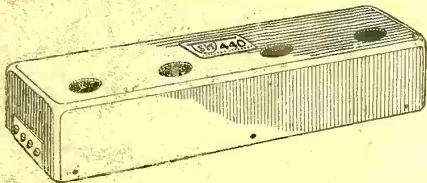

The 440 time amplifier has been developed for use by jewelers and advanced experimenters in receiving standard time signals transmitted daily by the Naval Observatory Station at Arlington, Va. (NAA).

Consisting of a three stage tuned R. F. amplifier and detector, it requires only batteries, phones, antenna and ground leads, and four 201-A tubes to be put in operation. The unit has been pre-tuned at the factory to Arlington's exact wavelength, thus eliminating all operating adjustments and rendering the amplifier capable of receiving but a single wavelength. Price, \$35.00.

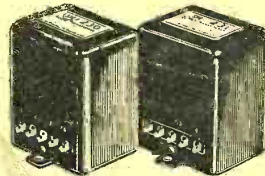

S-M 230 and 231 push-pull audio transformers are the latest development in high quality audio amplifying equipment. They account for the remarkable quality of the 660 Unipac, and for its tremendous undistorted power output.

Type 230 input transformer characteristics are similar to those of the famous 220 transformer, except that it is provided with two 3:1 secondaries, thus allowing its use as a 6:1 audio transformer if desired.

Type 231 has an extra primary, otherwise is similar to the 221 output transformer, and is designed to boost low note reproduction. It may also be used with 112 and 210 tubes to obtain maximum undistorted power output.

230 and 231 transformers, in a push-pull circuit with two 171 tubes will provide greater undistorted power than a 210 tube, but may be used with 201-A, 112, 171 or 210 tubes. Price, each \$10.00.

Leadership in any line of endeavor, though once gained, cannot be retained without effort. The penalty of leadership is in the fact that greater effort and accomplishment is actually necessary to retain it than is frequently exerted to gain it!

Leadership in the field of radio parts manufacturing and engineering has been gained by Silver-Marshall, Incorporated, only through the sheer excellence of S-M products and engineering. In the past season, S-M audio transformers set standards for size and excellence that are—a year later—just beginning to be copied. S-M transformers introduced the 5,000-cycle cut-off in audio amplification, a revolutionary development, but to be found adopted by the most progressive manufacturers this season! And so with S-M output transformers—they are the only types actually boosting low note reproduction, helping loud speakers toward perfect performance. Again, S-M has led, and this season other manufacturers will follow with improvements that S-M introduced a year ago.

Behind every S-M transformer that has ever been sold was a money-back guarantee that it would give better reproduction than the buyer had ever heard. Yet the factory returns were less than one in every four thousand—a record of 3,999 satisfied users out of every four thousand!

The S-M Shielded Six receiver kit set a standard in home built receivers that has not been approached, and in 1927 it will continue as the finest receiver kit money can buy.

S-M plug-in coils are everywhere, for every use. Their reputation has gone beyond America, and in England they have served as the design basis for nearly every popular English coil!

The S-M Reservoir B power supply was the first unit to offer the advantages of ballast tube voltage regulation—the first and only power supply ever to be sold with a guarantee against “motor-boating” and all other eliminator troubles. And not a single return to date.

It is achievements such as these—the will to give the best and the ability to do it—that have earned for S-M absolute leadership in the radio parts field in less than three years.

Mindful of the penalty of leadership, S-M offers four new items—the most powerful power pack ever developed for home use, push-pull transformers as far ahead of those of three years ago as 220s are of all other types, and a jeweler's time receiver representing the finest of engineering in long wave amplifiers.

S-M has faith in these products, knowing that they are RIGHT, and backs them with a satisfaction or money-back guarantee.

SILVER-MARSHALL, Inc.

848 West Jackson Blvd.

Chicago, U. S. A.