

RADIO'S GREATEST MAGAZINE

# RADIO NEWS

REG. U.S. PAT. OFF.

JUNE  
25 Cents

Over 200  
Illustrations



BROADCAST  
**WRNY**  
STATION



Edited by HUGO GERNSBACH

## THE RADIO GUN

(See Page 1320)



EXPERIMENTER PUBLISHING COMPANY, 230 FIFTH AVENUE, NEW YORK

# Cunningham RADIO TUBES



*Superior in Quality  
Outstanding in  
Performance*

*The Choice  
of  
Millions*

*You can depend  
on their performance*

because Cunningham Radio Tubes  
are guaranteed against electrical and  
mechanical defects in construction

*Look for the name Cunningham  
on the Orange and Blue Carton.*

E. T. CUNNINGHAM, INC.

NEW YORK

CHICAGO

SAN FRANCISCO

Manufactured and sold under rights, patents and inventions owned and/or controlled by Radio Corporation of America.

**Since 1915 STANDARD for all sets**



# EARN \$75<sup>00</sup> a week — in Your Spare Time

**J**OINING the Radio Association enables you to cash in on Radio *now!* Follow its success-proven plans and you can earn \$3 an hour, in your spare time, from the very first. Over \$600,000,000 is being spent yearly for sets, supplies, service. You can get your share of this business and, at the same time, fit yourself for the big-pay opportunities in Radio.

### Founded on a New Idea

Members of the Association do not wait for months before they make money out of Radio. Without quitting their jobs, our members are earning \$25 to \$75 a week spare time by building "tailored" radio sets, serving as "radio doctors," selling ready built sets and accessories, or following one of the many profit-making plans of the Association.

### Earned \$500 in Spare Hours

Hundreds earn \$3 an hour as "radio doctors." Lyle Follick, Lansing, Mich., has already made \$500 in spare time. Werner Eichler, Rochester, N. Y., is earning \$50 a week for spare time. F. J. Buckley, Sedalia, Mo., is earning as much in spare time as he receives from his employer.

*We will start you in business.* Our cooperative plan gives the ambitious man his opportunity to establish himself. Many have followed this plan and established radio stores. Membership in the Association has increased the salaries of many. Scores are now connected with big radio organizations. Others have prosperous stores.

A year ago Claude De Grave knew nothing about Radio. Today he is on the staff of a famous radio manufacturer and an associate member of the Institute of Radio Engineers. He attributes his success to joining the Association. His income now is 350% more than when he joined.

### Doubled Income in Six Months

"I attribute my success entirely to the Radio Association," writes W. E. Thon, Chicago, who was clerk in a hardware store before joining. We helped him secure the managership of a large store at a 220% increased salary.

"In 1922 I was a clerk," writes K. O. Benzing, McGregor, Ia., "when I enrolled. Since then I have built hundreds of sets—from 1-tube Regenerative to Superheterodynes. I am now operating my own store and my income is 200% greater than when I joined the Association. My entire success is due to the splendid help it gave."

### Easiest Way Into Radio

If ambitious to become a Radio Engineer, to fit yourself for the \$3,000 to \$10,000 opportunities in Radio, join the Association. It gives you a comprehensive, practical and theoretical training and the benefit of our Employment Service. You earn while you learn. You have the privilege of buying radio supplies at wholesale. You have the Association behind you in carrying out your ambitions.

### ACT NOW—if you wish Special Membership Plan

To a limited number of ambitious men, we will give Special Memberships that may not—need not—cost you a cent. To secure one, write today. We will send you details and also our book, "Your Opportunity in the Radio Industry." It will open your eyes to the money-making possibilities of Radio. Write today.

### What a Membership Can Do for You

- 1—Enable you to earn \$3 an hour upwards in your spare time.
- 2—Train you to install, repair and build all kinds of sets.
- 3—Start you in business without capital, or finance an invention.
- 4—Train you for the \$3,000 to \$10,000 big-pay radio positions.
- 5—Help secure a better position at bigger pay for you.
- 6—Give you the backing of the Radio Association.

**A MEMBERSHIP NEED NOT COST YOU A SINGLE CENT**

RADIO ASSOCIATION OF AMERICA,  
4513 Ravenswood Ave.,  
Chicago, Ill.

Dept. RN-6

Gentlemen:

Please send me by return mail full details of your Special Membership Plan and also copy of your book, "Your Opportunity in the Radio Industry."

Name.....

Address.....

City..... State.....

# RADIO NEWS

Volume 9

JUNE, 1928

Number 12

## Contents of This Issue

Warm-Weather Radio By Hugo Gernsback 1303	Broadenstatistics 1325
Airplane Radio—Necessity or Luxury? By Orrin E. Dunlap, Jr. 1304	The "Electric Brain" and Its Language, By G. C. B. Howe 1326
Across the Frontiers of Europe by Radio By Golda M. Goldman 1306	England Goes in For Television 1328
Reception Acoustics—What It Means to the Listener By Charles Magee Adams 1310	Latest Novelty Developments in Radio 1329
How Many Stations on One Wavelength? By J. H. Barron, Jr. 1312	Radio Measures Human Nerve Impulses By Theodore A. Hunter 1330
A Britfisher Chats on Radio By E. Blake 1313	The Radio Beginner—An Audio Ampli- fier for the Extension Receiver 1332
A Real Radio Hound By Charles Magee Adams 1314	The Neutroheterodyne Receiver—8100 Prize Winner By Herbert J. Reich 1336
Shoppers Must Beware of the Radio "Gyp" 1315	Developing the Possibilities of a Horn By Chester Schenck 1342
Radio Takes Over the Geography Class By C. P. Mason 1316	The How and Why of Radio Filters By Fred H. Canfield 1344
List of Broadcast Station Calls 1318	Radio Patents By Philip S. McLean 1347
Some "Inside Stuff" for Radio News Readers 1319	Applying Ohm's Law to Radio Apparatus By Fred H. Canfield 1348
The Radio Gun—The Silent Weapon of the Future By Joseph Riley 1320	What Our Readers Think of Our New Policy 1350
The Port of Missing Airplanes By C. Sterling Gleason 1322	RADIO NEWS LABORATORIES 1352
The Listener Speaks By Himself 1324	Radiotics 1354
	I Want to Know By C. W. Palmer 1355
	What's New In Radio 1352
	Statement of Ownership, etc. 1361

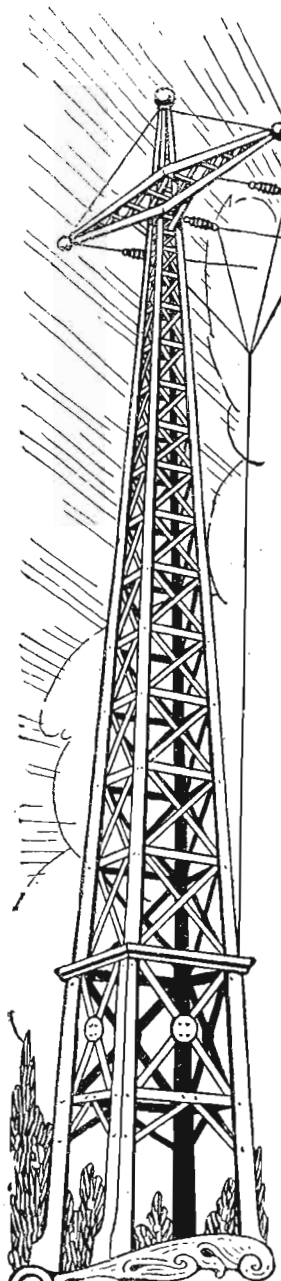

RADIO NEWS is published on the 10th of each preceding month. There are 12 numbers per year. Subscription price is \$2.50 a year in U. S. and possessions, Canada and foreign countries, \$3.00 per year. U. S. Coins as well as U. S. Stamps accepted (no foreign coins or stamps). Single copies, 25 cents each. Checks and money orders should be drawn to order of EXPERIMENTER PUBLISHING CO., INC.

All communications and contributions to this journal should be addressed to Editor, RADIO NEWS, 230 Fifth Ave., New York, N. Y. Unaccepted contributions cannot be returned unless full postage has been included. All accepted contributions are paid for on publication. A special rate is paid for novel experiments; good photographs accompanying them are highly desirable.

RADIO NEWS, Monthly. Entered as second-class matter, July 12, 1924, at the Post Office at New York, N. Y., under the Act of March 3, 1879. Additional entry at Burlington, N. J., and San Francisco, Calif. Title registered U. S. Patent Office, Copyright, 1928, by The Experimenter Publishing Co., Inc., 230 Fifth Ave., New York. The contents of this magazine are copyrighted and must not be reproduced in the United States without giving full credit to the publication. Translation into foreign languages must not be made unless permission is obtained from the publishers. Copyright in Germany. Reproduction of articles in Germany is reserved for Radio, Berlin 42.

The contents of RADIO NEWS are indexed in the Industrial Arts Index, copies of which can be found in every library.

RADIO NEWS is for sale at all newsstands in the United States and Canada, and at Brentano's, Ave. de l'Opera, Paris, France; European agents: S. J. Wise Et Cie, 40 Place Verte, Antwerp, Belgium.

HOW TO SUBSCRIBE FOR RADIO NEWS. Send your name, address and remittance to Experimenter Publishing Co., 230 Fifth Ave., New York. Mention the name of the magazine you are ordering. We also publish SCIENCE AND INVENTION, RADIO LISTENERS' GUIDE, AMAZING STORIES and FRENCH HUMOR. Write clearly.

RATES AND TERMS. The subscription rate for RADIO NEWS is \$2.50 per year (12 numbers). When remitting do so by check, money order, or registered letter if cash is enclosed. Avoid sending cash through the mail if possible. Subscriptions for less than one year are not accepted. Subscriptions may be made in combination with SCIENCE & INVENTION, RADIO LISTENERS' GUIDE, AMAZING STORIES and FRENCH HUMOR.

POSTAGE. We prepay postage in all parts of the United States, Mexico and island possessions. For foreign or Canadian subscriptions we require 50 cents in addition to the subscription price for additional postage charges.

CHANGE OF ADDRESS. Notify us as far in advance as possible. It requires several weeks to make an address change on our records. Always write clearly.

Published by **EXPERIMENTER PUBLISHING COMPANY, Inc.**

H. GERNSBACK, President

S. GERNSBACK, Treasurer

C. E. ROSENFELT, Secretary

Member: Audit Bureau of Circulations

Radio Magazine Publishers Association

Editorial and General Offices

230 Fifth Avenue, New York City

ADVERTISING DEPARTMENT

New York Office:

Rhodes & Leisenring,  
624 Graybar Building

Chicago Office:

Rhodes & Leisenring,  
307 North Michigan Avenue.

# This is the Way Radio Should be Sold—

Crosley dealers everywhere are advertising like this. Crosley dealers have a product behind which a great resourceful factory stands prepared to prove to the world that Crosley value is yet to be surpassed!

## Home is really the place to buy radio!

# Free Trial

in your home of this self contained

# ~~CROSLEY~~ JEWELBOX

NEW AC Neutrodyne

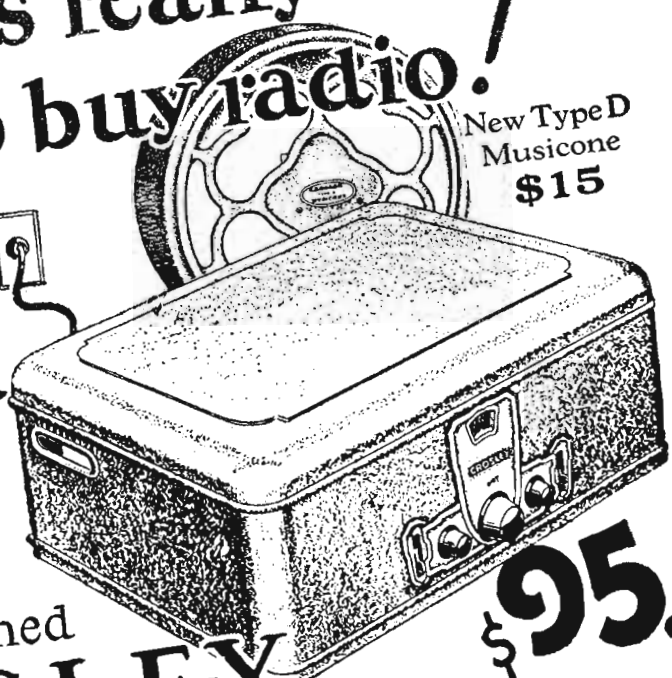

New Type D Musicone \$15

# \$95.

Here's a radio so good that anyone may try it BEFORE BUYING right in their own home! Compare it with your old set. Discover what far greater pleasure you will get from the political conventions this summer if you possess the Jewelbox! This new radio gives you every advanced improvement including some features obtainable only at more than twice the price. Send this coupon if you cannot call and we will install the Jewelbox for a free and satisfying trial in your own home.

A Crosley Dealer—  
Everywhere  
Mark (X) in front of Service you want.  
I would like to try the new Jewelbox in my home FREE without obligating myself to purchase.  
Please send me literature about the new Crosley Jewelbox and the easy payment plan of purchase.

Name.....  
Address.....  
"You're there with a Crosley"

## INDEX TO ADVERTISERS

A	Page	D	Page	L	Page	S	Page
Alox Company, The.....	Back Cover	Deutschmann Co., Tube.....	1365	Lacault Radio Electric Labs., R. E. ....	1370	Scott Transformer Co.....	1367
Accusti Cone .....	1365			Lacey & Lacey .....	1373	Sec Jay Battery Co.....	1385
Acme Wire Co., The.....	1361	E		Leutz, Inc., C. R.....	1363	Seymour Institute .....	1364
Aero Products, Inc.....	1373	Electrad, Inc. ....	1365			Smith, E. Hawley.....	1370
Aerovox Wireless Corp.....	1367	Electric Specialty Co.....	1377	M		Starrett Mfg. Co.....	1364
All Radio Co.....	1365	Electro-Chemical Co. of America .....	1391	M. & H. Sporting Goods Co..	1381		
American Bosch Magneto Corp.	1367	Erie Fixture Supply Co., Inc..	1360	Mack Co. ....	1375	T	
American Mechanical Labs. 1365-1367-1370-1373-1381		F		Midwest Radio Corp.....	1383	Telephone Maintenance Co.....	1364
American Transformer Co.....	1389	Fanspeaker Radio Co.....	1381	Muter Co., Leslie F. ....	1373	Teleplex Co. ....	1379
Amrad Corp., The.....	1381	Fansteel Products Co.....	1364			Thordarson Elec. Mfg. Co.....	1357
		Formica Insulation Co., The.....	1387	N		Tower Mfg. Corp.....	1367
B		Freshman Co., Inc., Chas.....	1360	National Radio Institute.....	1301	Townsend Labs. ....	1365
Barawik Co., The.....	1365-1383-1385	Frost, Inc., Herbert H.....	1381	Norden-Haack, Inc. ....	1375	Tyrman Electric Corp.....	1379
Benjamin Elec. Mfg. Co.....	1391	G					
Brady, John B.....	1385	General Radio Co.....	1375	O		U	
		H		Outdoor Enterprise Co.....	1387	Underground Antenna Co.....	1359
C		Hamilton-Carr Corp. ....	1381			Underground Aerial Systems...	1381
C. E. Mfg. Co., Inc.....	1367	Hammalund Mfg. Co.....	1375	P			
Carborundum Co., The.....	1377	Harco Co., The.....	1375	Parker, C. J.....	1360	W	
Carter Radio Co.....	1379			Press Guild Inc., The.....	1371	Walker Co., The Geo. W.....	1364
Central Radio Labs.....	1379	I				Warren Electric Co.....	1375
Chemical Institute of N. Y., Inc. ....	1378	Ideal Werke .....	1383	R		Western Radio Mfg. Co.....	1367
Chicago Radio Apparatus Co.....	1363	Illinois Transformer Co.....	1381	Radfall Co. ....	1387	World Battery Co.....	1387
Cloverleaf Mfg. Co. Inside Back Cover		Independent Electric Works...	1363	Radio Association of America..	1297		
Consrad Co. Inc., The 1364-1370-1372-1376		J		Radio Engineering, Inc.....	1358	X	
Consumers Radio Co.....	1364	J-M-P Mfg. Co.....	1379	Radio Equipment Co.....	1360	N-L Radio Labs.....	1385
Craftsman Radio Products.....	1377	Jewell Electrical Inst. Co.....	1377	Radio Institute of America.....	1369	Y	
Crosley Radio Corp.....	1299			Radio Specialty Co.....	1392	Yashly Mfg. Co.....	1391
Cummings Radio Corp.....	1377						
Cunningham, Inc., E. T. Inside Front Cover							
Curtan Mfg. Co.....	1302						

# Now! in limp, suede leather binding

## S. Gernsback's Radio Encyclopedia

THE most valuable of Radio Books—S. Gernsback's Encyclopedia—*now the most beautiful*. This foremost Radio Encyclopedia is now offered in this luxurious new binding to meet the demand for a more handsomely bound volume. The limp suede leather edition sells for \$5.00. The Keratol-leather stiff binding still can be had for \$2.00.

Remember—this is an encyclopedia—not a dictionary! It took over two years of intensive labor to compile it. It is the first Radio Encyclopedia ever published.

S. Gernsback's Radio Encyclopedia contains the

meaning of every word and phrase used in the entire Radio Art. Every circuit, part and apparatus is thoroughly explained. A complete cross index is just one of the many features of this remarkable book.

There are 1,930 definitions—549 diagrams, photographs and drawings—all simple and easily understood. The book is nearly 1 inch thick and measures 9x11 inches.



S. GERNSBACK  
230 Fifth Ave., New York City  
Radio Encyclopedia. I will pay post-  
man.  
 Limp suede leather binding  
\$5.00 plus postage.  
 Keratol-leather binding  
(check which binding you want)  
plus postage.  
Name.....  
Address.....  
Town.....  
State.....

**SEND NO MONEY**  
Simply pay the post-  
man on delivery.  
Over 25,000 copies in the  
still binding already sold.

S. GERNSBACK, 230 FIFTH AVENUE, NEW YORK CITY



# Get Your Share of the BIG MONEY

**Read What Big Money these N. R. I. men are making**



**High as \$78 a Week**  
"I am only about half way through the course, but I have made as high as \$78 in one week in a retail Radio store. I estimate my total income as the result of my knowledge of Radio, around \$3,000 to date. I know I could not have picked a better course." **FRANK REESE**, 204 Walnut St., Gettysville, Pa.

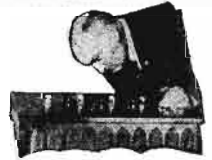

**\$70 in One Day**  
"I am in business for myself and recently made \$70 in one day. I estimate that the Radio training I received from you will be worth tens of thousands of dollars to me in the future." **T. M. Wilcox**, Belle Island, Newfoundland.

**Learn Radio the Practical Fascinating Way**

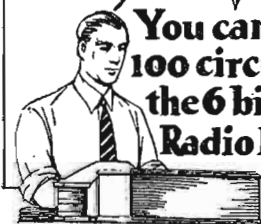

**You can build 100 circuits with the 6 big outfits of Radio Parts I give you 3 of the 100 you can build**



**Employment Service to all Graduates**

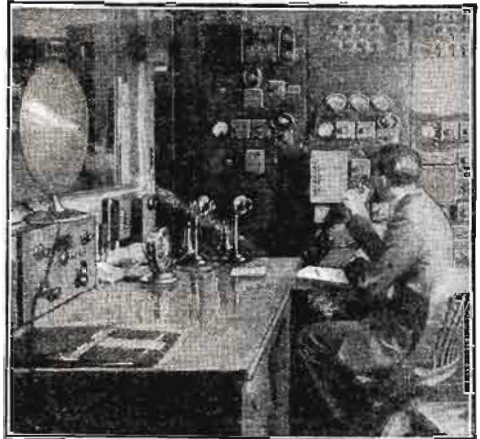

Why be satisfied with \$25, \$30 or \$45 a week when the good jobs in Radio pay \$50, \$75 and all the way up to \$250 a week. The astounding growth of Radio has already created three hundred thousand jobs in a few short years. Small and large fortunes are coming out of this new business every year. Twenty different branches offer you work that's almost romance with practically no limit to the money you can make. Manufacturing, selling, repairing, servicing, assembling, installing sets, operating on board ship which gives you world-wide travel without expense, operating a broadcasting station, and many other lines of work are fully explained in "Rich Rewards in Radio," my 64-page FREE book. Send for it today.

**Learn at Home in Spare Minutes**

No need to leave home. Hold your job. I'll bring your training to you. You can learn during your spare time. My easy-to-learn, practical course has put hundreds of fellows who had only a few minutes a day to study into big pay jobs. You don't have to be a college or high school graduate to become a Radio Expert. Many of my students and graduates now making big money didn't even finish the grades.

**You Get Six Big Outfits Without Extra Charge**

I teach Radio the right way—the practical way. I give you six big outfits of Radio parts (not toys) and show you how to build approximately 100 different circuits, locate, repair, and remedy all receiving set troubles. Three outfits you build are shown on this page. You build practically every type of receiving set known today. Thus you learn the "why" and the "how"—get a complete, thorough, rounded-out knowledge that shows its worth in your pay envelope. Full details in my big book.

**Earn \$15, \$20, \$30 a Week Extra While Learning**

Delos Brown, South St., Foxboro, Mass., made \$1,000 from spare time jobs before he even finished his course. Frank Toomey, Jr., Piermont, New York, made \$833. G. W. Page, 1807 21st Ave., Nashville, Tenn., says the course brought him \$935 spare time profits. No need to scrimp, save, and deny yourself good things to pay for this course. It's the world-famous course that pays for itself.

**Your Money Back If Not Satisfied**

That's the agreement I make with you when you enroll. It's my way of showing you that I'll give you the training and service you need and want. You are the only judge.

**64-Page Book FREE for the Asking**

I will gladly send you my 64-page book of information on N. R. I. training and the money-making opportunities in Radio without a penny's cost to you. Send for it NOW. Clip or tear out the coupon today. Find out what Radio offers you and how my Employment Department helps you get into Radio after you graduate.

**J. E. SMITH, President**  
Dept. 6-S  
Nat. Radio Institute, Washington, D. C.

# RADIO

*I'll Show you how*  
**MANY MEN**  
*are* **MAKING**  
**\$50 to \$250**  
**A WEEK**  
*in this New*  
**Business**

**Send for FREE 64 Page Book giving facts on this new opportunity**  
**Act Today**

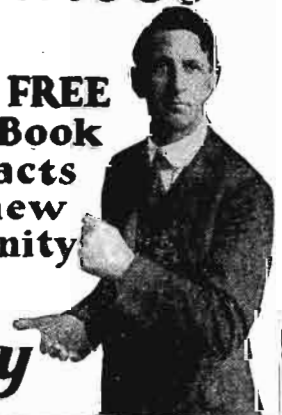

**Mail This FREE COUPON NOW**

J. E. SMITH, President  
Dept. 6-S, National Radio Institute,  
Washington, D. C.

Dear Mr. Smith: Without obligating me in any way, please send me your Free-book, "Rich Rewards in Radio," with information on your practical Home Study Radio Course.

Name..... Age.....

Address.....

City..... State.....

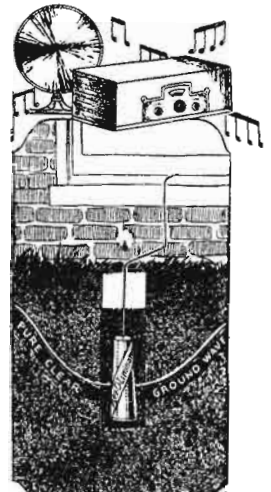

**EASY TO INSTALL**  
 Just dig a small hole about 6 inches in diameter and drop Aer-O-Limiter into it.

**Astounding  
 Successful**

# Ground Antenna

**Gets Winter Reception in Summer!**

**Clearer Ground Wave Reception  
 Allows Greater Distance**

**H**UNDREDS of satisfied users of the sensational Ground Antenna—Aer-O-Limiter—are wondering how they ever got along without it. All over the country radio owners are finding marvelous satisfaction in freedom from static and noise interference. This revolutionary improvement of reception comes from hooking your receiver to Ground Wave Reception. Radio engineers tell you that the broadcast wave through the ground is in most cases almost static-free and with rare exception carries no noise interference.

The rapidly increasing army of Aer-O-Limiter owners also enjoy and appreciate the natural human tone and clarity of this Ground Wave Reception. If you haven't tried it you can't imagine the difference!

Another advantage users have found with Aer-O-Limiter is the surprising DX they get. Distant stations formerly drowned out by static or noise interference of air waves now come in clear as a bell. Selectivity is improved because, with pure clear Ground Wave Reception, you can pick up and log signals that before were lost in the jumble of shrieks

and howls so common in DX reception through air waves.

You shouldn't deprive yourself of the new thrill of pure clear ground wave reception a day longer than necessary. We let you prove it for yourself.

## FREE TRIAL

*Make this thrilling test at our risk!*

Install an Aer-O-Limiter (Ground Antenna). Leave your old overhead aerial up. Try out on a night when static is bad. If you do not get a wonderful improvement in freedom from static, greater selectivity and clear, sweet tone without interfering noises, if you can't get good reception on stations that are drowned out by static on your old aerial, you need not pay us a red cent for this test. Send coupon at once for scientific explanation of Aer-O-Limiter (Ground Antenna), proof of performance, and our conclusive iron-bound guarantee, and remarkable Free Trial Offer—Mail Coupon TODAY!

### Read This Proof

From 208, Golf Terrace

Wilmette, Ill.

"Your Aer-O-Limiter works fine. You could hardly believe what a difference it makes in the clearness and tone of my set. It certainly seems to take out nearly all the static and power noises that have been bothering me, too."

"Mine is only a three-tube set, but with the Aer-O-Limiter I can pick up outside stations every night, clear and with volume. You must be right about the static-free ground waves."

L. BEAUVAIS.

From Kimberly Radio Corp.

328 N. Michigan Ave., Chicago

"We have used the Aer-O-Limiter with great satisfaction. It removes the necessity of the unsightly outside aerial and improves reception materially. It reduces static and outside interference, and produces very clear tones on distant stations, with good volume. It increases selectivity greatly. We would recommend it to anyone for the best results on his set."

P. R. KIMBERLY, President.

# Aer-O-Limiter (Ground Antenna)

Passed by the National Board of Fire Underwriters.  
 Meets requirements of the National Electrical Code

Endorsed by foremost Engineers and Dealers.

## CURTAN MFG. COMPANY

Dept. 827-H, 154 East Erie Street Chicago, Ill.

### Rush This Important Coupon

Curtan Mfg. Co.,  
 154 E. Erie St., Dept. 827-H,  
 Chicago, Ill.

Please send me at once complete description of Aer-O-Limiter, with details of guarantee, Scientific Proof, and FREE TRIAL OFFER.

Name.....

Address.....

City.....

State.....





Editorial and General Offices, 230 Fifth Avenue, New York

Vol. 9

JUNE, 1928

No. 12

## Warm-Weather Radio

By Hugo Gernsback

**N**OW that warm weather is again upon us—speaking for the great majority in this country, at least—it becomes necessary once more to see what the "dog days" have in store for us, so far as radio reception is concerned. It is a most healthy sign that, as year after year rolls by, activities in radio during the summer consistently increase in a most encouraging manner. When broadcasting first started, in 1921, and while we still had our crystal sets, summer played havoc with our radio reception.

To be sure, in those days we used head-telephone receivers, and it was not considered very healthy or prudent to sit with a pair of these clamped to your ears while lightning was playing around the house. Nowadays there are few people using head receivers (in this country, at least), because the loud speaker has taken the country by storm. Cases of injury by lightning, while the victims were using head receivers, have always been exceedingly rare all over the world; while, in fact, there is no case on record, during the past two years, in which a person has been injured by lightning when loud speakers were being used.

Several years ago, RADIO NEWS offered \$300.00 for authentic information concerning cases in which lightning had hit a radio aerial and damaged property or injured people as a result. No properly-authenticated instance was presented from the United States and, when the prize was finally claimed and paid, it went to Canada. Even in this case, the lightning did not hit the radio aerial first, but struck another piece of metal, from which a secondary discharge leaped to the aerial, doing the damage. It may therefore be said that, so far as the radio installation is concerned, people need not worry about lightning.

If the connections of the aerial have been made as prescribed by the insurance regulations, and a good lightning arrester has been installed, there is practically no danger, either to the radio set or to the person who uses it. As a matter of fact, most people use their radio sets throughout the summer and, unless lightning actually plays overhead, they go on using the instruments just the same.

One of the most encouraging things about radio in general, nowadays, is that summer static does not bother us as much as it used to when we had our crystal sets, or even our one- and two-tube sets in the early days of broadcasting. The reason is simple. When we were using crystal sets or one-, two- or even three-tube sets, and static was bad, the latter was sufficient to override the weak radio signals; and it became most annoying and tiresome to listen to a radio program under such circumstances. With our present-day high-powered sets, however, the situation is changed entirely. It is now possible to build up a signal to such an intensity that the resultant sounds will easily override the usual static, although the latter is amplified also. Unless there is a thunderstorm quite close by, the selectivity and amplifying power of the set are enough to discount the static and make the program at least enjoyable. This is particularly true this year; because our new alternating-current sets are generally of great power. With the volume control turned all the way up, there is little difficulty in getting practically any local program, and even some of the distant ones. Though static is at its worst when there are no signals from the station to which a receiver is tuned, when the signals are coming in strongly the static loses a great deal of its former importance.

Another factor of importance is the increased power of the broadcast stations themselves. With station outputs ranging up to 50,000 watts, the signal-to-static ratio is considerably higher today than it was five or six years ago, when a broadcaster with 500 watts in the antenna was inferior to no one.

It would seem, therefore, that at this time the static bugaboo is on the decline; at any rate it is not as worrisome as it was even a year ago. It would seem that, for the present, the answer to static is simply more power.

Then too, now that we have sufficient amplifying power in our up-to-the-minute receiving sets, it becomes possible to enjoy our programs, except during thunderstorms with lightning playing overhead, by following a simple procedure.

Most alternating-current sets have a power and volume which were not dreamed of, even a year ago. If static bothers us unduly, all we have to do is simply to disconnect our outdoor aerial. Probably few people go in for DX fishing in the summer time, anyhow, and what they are most interested in is a good program from a station within one hundred or two hundred miles. Signals with good intensity can then be brought in by dispensing with the usual outdoor aerial and using an indoor aerial, which may be run around the molding of a room. If this is not practical, a spiral made of about one hundred feet of ordinary bell wire, coiled on the floor of the room in which the radio set is kept and covered with a rug or carpet, makes an excellent indoor aerial.

Another excellent indoor aerial can be improvised by running a wire to any metallic part of a house telephone. If you are using an alternating-current set, it is a good precaution to put a one-microfarad fixed condenser between the telephone and the aerial binding post.

Then there is another favorite system, wherein the usual cold-water-pipe is used as a ground, and the aerial wire is run to the radiator system. In this case also the condenser just described should be used. This system does not always work, in every locality, and a little experimenting with it may be necessary.

By using indoor aerials or aerial substitutes such as those already mentioned, two things are accomplished: first, the static effects are cut down to a very large extent. Second, those who are nervous and afraid of lightning need be so no longer; because such aerial substitutes practically do away with any possible danger or risk from lightning.

A third substitute, which is coming more and more into favor, is the underground or buried aerial. This system was first devised by Dr. James Harris Rogers during the great war, when he discovered that signals from Europe could be brought into his receiving station in Maryland, while lightning actually played overhead. The buried underground aerial is remarkable in that it collects very little static; but, of course, aerials of this kind can not be used unless one lives in a residence with grounds, or has access to a backyard, where the device can be buried. It is also necessary, for best results, to run a shielded cable to the set.

When radio was a luxury, some years back, people did not think it was important to use their radio sets during the summer time; but today a radio set is a necessity, almost to the same extent as our telephones and automobiles, which also at one time were luxuries. Our radio broadcast stations are rendering a tremendously important service to the community. They give us weather and time reports, news bulletins, educational talks, recipes and domestic advice for the housewife, and other items of information; some of which, such as storm warnings and market prices, are of great importance to residents in certain sections of the country. Besides this, we get the radio entertainment thrown in for good measure and, as we know, this entertainment is steadily mounting to a higher and higher plane. I feel that all of us can afford to, and should, listen in to some of the more important radio features this summer. With the political conventions on the air, it would seem that no patriotic citizen has any right to shut off his set and put it away until the cold weather comes back.

All in all, it may be said that this is the first year in which summer radio is becoming of such real importance that to do without it is as disadvantageous as the old-time way of laying up the car through the winter.

Mr. Hugo Gernsback speaks every Tuesday at 9.30 P. M. from Stations WRNY (326 meters) and 2XAL (30.91 meters) on various radio and scientific subjects.

# AIRPLANE RADIO

Necessity  
or  
Luxury?

by  
Orrin E. Dunlap, Jr.

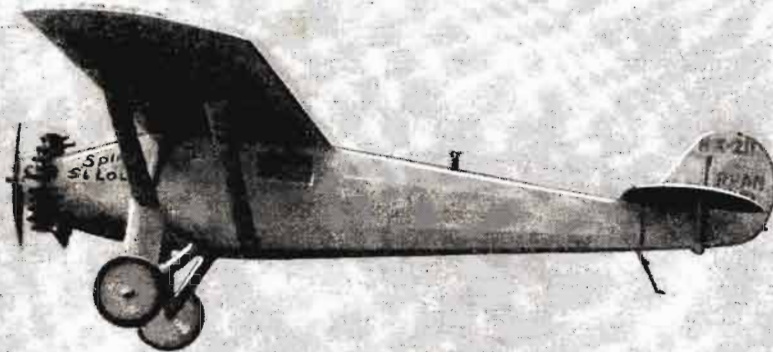

Above: Col. Charles A. Lindbergh's plane, "The Spirit of St. Louis," in flight.

**C**OLONEL Charles A. Lindbergh, up to the day that the *Spirit of St. Louis* alighted on the flying field at Havana, had flown for 460 hours, covering more than 40,000 miles in a total of 467 flights, without carrying radio equipment. Does this prove that radio is nothing

but excess baggage on board aircraft? Some say "Yes!" and others say "No!"

Those contending that radio is not needed in aviation point out that most of the planes lost at sea, including *Old Glory* and *The Dawn*, both of which carried radio, vanished silently. Radio did not save them. Sev-

eral, and notably the *Dallas Spirit*, whose radio flashed a cryptic report of a tail-spin over the Pacific, were lost in spite of their equipment. Radio merely gave a slight indication of the scene where disaster lurked, and what had happened; but it did not effect a rescue. Radio was responsible, in several cases, for planes and ships rushing to the spot from which the last urgent message told that tragedy was tugging at the wings. Nevertheless, the sea maintained its secret and the men were held captives, forever. It surrendered only the broken wing of *Old Glory*, which had so proudly sailed into the east to conquer the Atlantic.

Up to the time that the *White Bird*, carrying the bravest of the brave, Captain Charles Nungesser and Captain François Coli, left the airdrome at Le Bourget, bound for America, the Atlantic had been crossed once only by a non-stop plane, but seven times by dirigibles and point-to-point airplane hops. Most of these flights, and the other and unsuccessful attempts to span the sea, proved conclusively that radio is a most valuable asset, especially after the airplane vanishes from sight of the shore. The invisible waves that come back from the clouds relieve anxiety; they give a running story of the flight, and, last but not least, if the plane is forced to drop to the surface of the sea a call can be dispatched for help.

Has not radio fulfilled its duty if it gets the distress signal into the air and starts rescue efforts? Should radio be held responsible if the sea swallows the plane and the pilots? Some day an aviator on a trans-Atlantic cruise will be forced down, later to be rescued. Then, radio will be hailed as a savior; but as long as fliers are lost, radio will be deemed by some as non-essential.

What does Clarence Chamberlin think about it? He flew to Germany without carrying radio equipment.

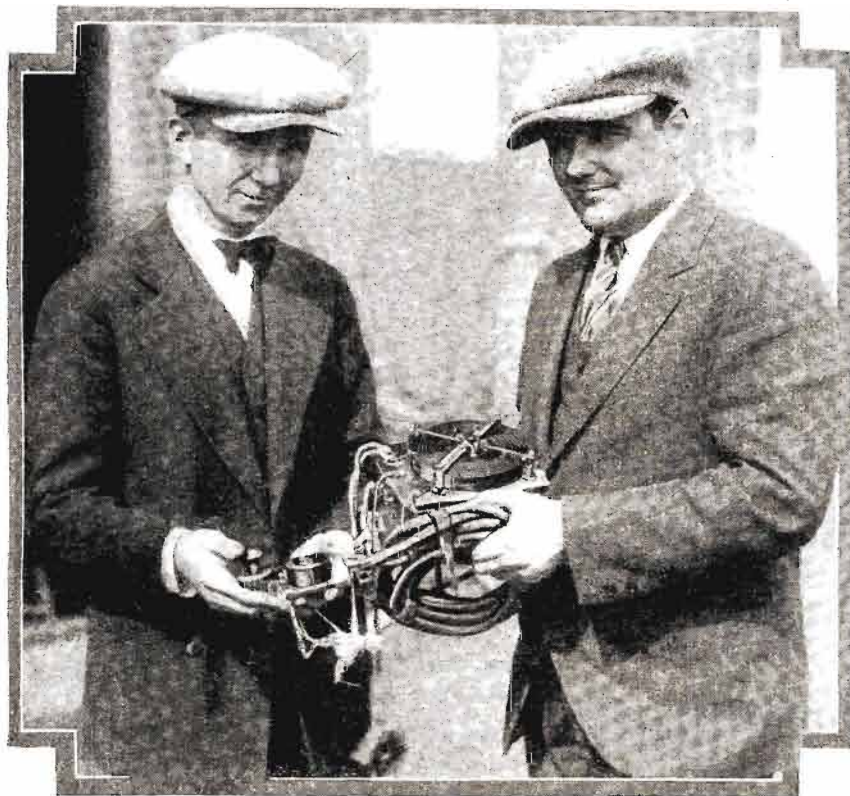

Clarence Chamberlin (left) and the late Lloyd Bertand (right) holding a small portable transmitter designed for airplane service. Bertand was lost with the ill-fated "Old Glory."

CHAMBERLIN'S EXPERIENCE

"The importance of radio in aviation cannot be overestimated," said the noted pilot shortly after he returned with his laurels. "The development of flying, especially the establishment of commercial and long-distance routes, depends to an almost incalculable extent on the development of radio on planes.

"When we planned the flight to Europe we intended to use radio, but when we finally selected our route we found that it would take us several hundred miles off the ship lanes. As our transmitter had a daylight range of only two hundred miles, we decided that it would be useless to carry the extra weight, when it would be of no help to us if we were forced to make a landing on the water.

"The Berlin flight, however, determined me in one thing. If I should ever attempt to repeat it in the future, I would insist that the plane be equipped with adequate radio installation. By "adequate," I mean a transmitter with a sending radius of 500 miles or more. There has been considerable discussion over the added weight with which radio burdens the plane. The set we planned to use would have reduced our flying range not more than 150 miles. If it comes to the question of 150 miles or safety, and if the future of aviation depends upon the answer, I should say safety and radio with the shorter flying range."

"I want to enlarge my statement that the development of aviation awaits the development of radio," said Chamberlin. "Even if flying conditions were almost excellent, radio would make long-distance flights more practicable; but when flights must be made

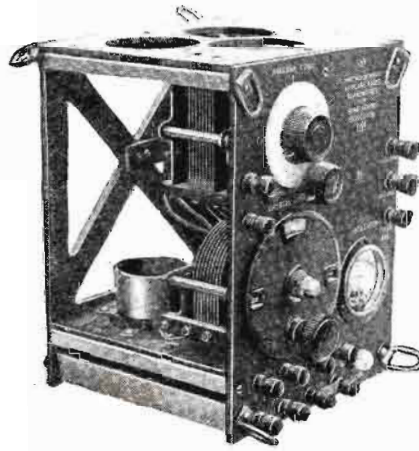

This is the little 44-meter transmitter carried by Commander Richard E. Byrd on his history-making flight over the North Pole.

through storms, fog, heavy weather and darkness, and when sudden changes of weather may be encountered at any time during the flight, radio is almost indispensable. Before commercial aviation in this country can maintain schedules that are comparable with those of railroads, aviation must be linked with radio. We have the pilots; we have the planes; all we need is radio!"

SENDING APPARATUS NEEDED

All agree that a transmitter on a plane in distress is more useful than a receiving set. It is not as important that the aviators intercept messages, as it is for others to

hear the "SOS" and position report. Furthermore, a direction-finder can be trained upon the waves, no matter whether they make sensible messages or not. Just a series of dashes, broadcast at intervals, enables a rescue ship to follow in the direction of the transmitter and finally arrive at the spot.

The NC-4 naval seaplane, the first airplane to cross the Atlantic, in May, 1919, proved the value of radio on an oceanic flight. It was not many hours after the NC-4 and her sister ships, NC-1 and NC-3, hopped off from Rockaway that the importance of radio equipment was realized by the men on the planes and on shore. The NC-4 developed trouble soon after she had sailed over Boston and was forced to descend at sea. Operators on the land noticed that the NC-4 reported motor difficulties. Soon the plane was silent. Messages were sent to the sister ships asking if they could see the NC-4. They said that she was not in sight.

The naval operators at Otter Cliffs, Bar Harbor, Me., had been listening to the pioneers from the time they had hopped off about noon. It was now 4 o'clock. They checked their radio compass bearings and found that the last signal radiated by the NC-4 showed that she was off Chatham, Mass. This information was broadcast to destroyers. A search began along the line of the radio bearing. The NC-4 was found by the destroyer McDermott at sunrise the next morning. The airship ran across the surface of the sea on its own power and, after repairs were made at Chatham, Newfoundland, where the NC-1 and NC-3 were waiting.

(Continued on page 1363)

Right: A portable superheterodyne used on a balloon during some recent experiments. The aerial wire is suspended on the hand reel at the left, its end being weighted by a lead "fish."

Below: Two typical airplane radio outfits, which operate on storage batteries. The loop tube on the left is a guide through which the aerial wire is lowered beneath the body of the plane.

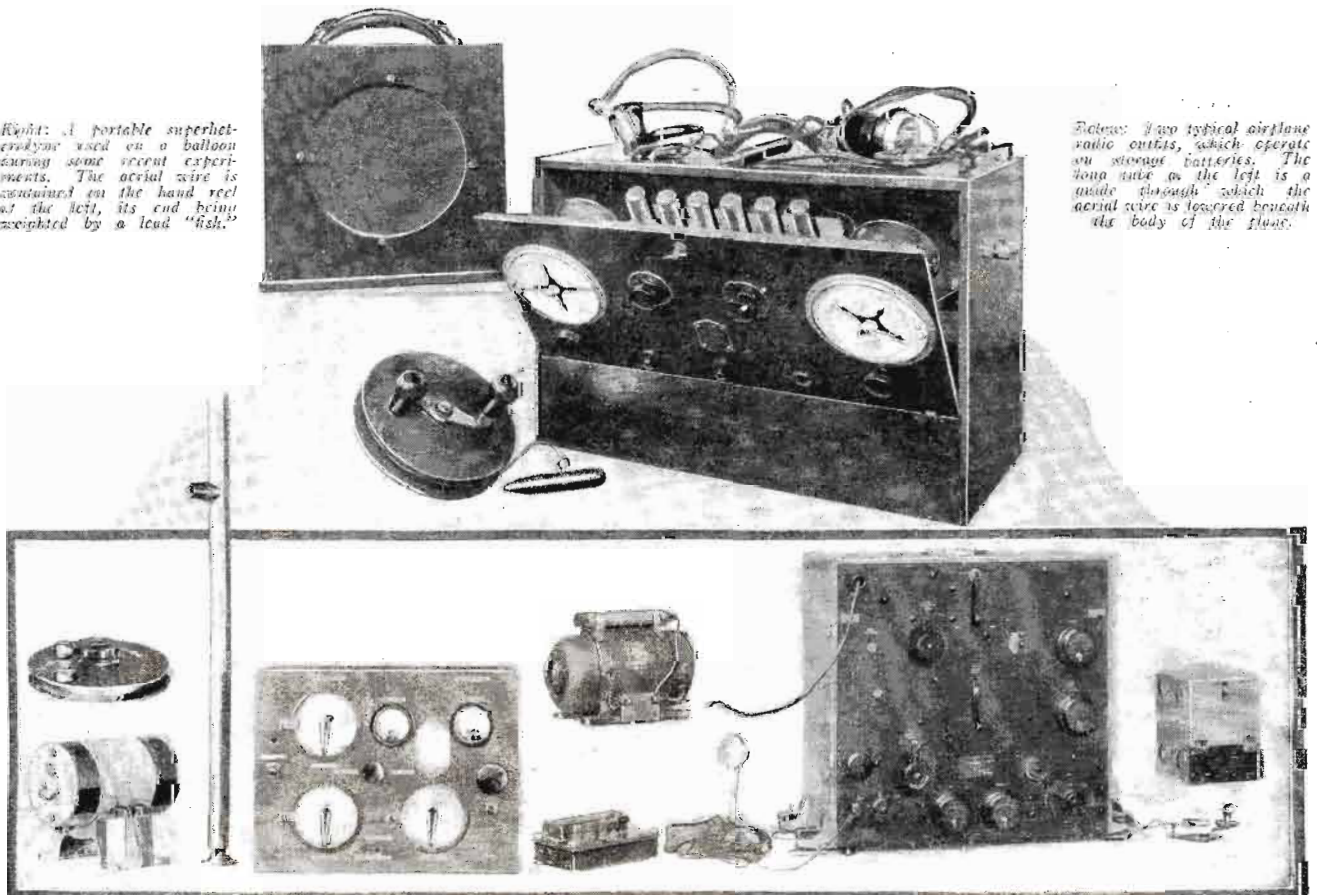

# Across the Frontiers of Europe by Radio

The Romance of Exploring the Ether  
in a Many-Tongued Old World

By Golda M. Goldman

THE radio set is of course the best little device for arm-chair travel that has even been invented; but those of you who listen in only to the programs of the United States cannot possibly have the thrills which come to the listeners in Europe. Despite the millions of square miles of territory and the almost innumerable fine stations, every announcer's voice, as it comes through your loud speaker, is talking English. Just as the novelty of traveling about the United States will never be able to compete with the thrill of crossing European frontiers, hearing foreign tongues, and passing customs inspectors—so is a radio trip from state to state lacking in the picturesqueness that we Parisian auditors enjoy.

With us, there is frequently the uncertainty of finding out what we're listening to. Feeling around for distance is a complicated process; for European stations broadcast, some of them on short and some on long wavelengths, with an enormous distance between. For instance, there is Copenhagen, (Denmark) on 337 meters, and the Eiffel Tower, Paris, on 2,650 meters. The European radio apparatus is therefore made so that you may go exploring for both sets of wavelengths, and occasionally a station strays off its beaten path and causes you all sorts of excitement.

To the Sorbonne attaches a tradition of venerability dating back to its foundation in 1255; with an erection of more modern buildings in the middle of the seventeenth century. The writer of this article conducts a course in current events and English literature, broadcast from the Eiffel Tower. The latter structure is shown at the right, with the Trocadero between its legs.

© Herbert Photos

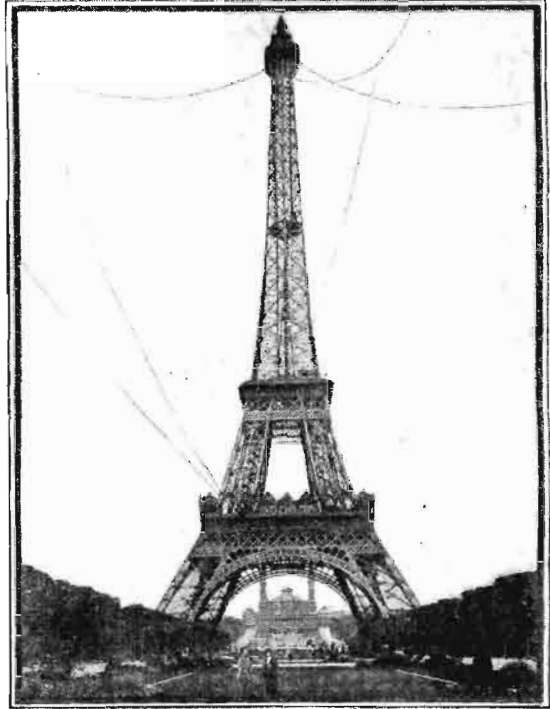

I'll give you an example of one of our "quiet" Sunday evenings of travel via radio last January. We had heard America a few days before at 2 A. M. Paris time (9 P. M. in New York), and very pale indeed had been our results on WEAJ and WGY, as we have only a loop aerial. However, our audio-frequency transformers evidently felt that they had done their duty; for the next day they burned out completely! Equipped with new ones, we were delighted to find our results better than ever, and the operator went afield with a vengeance. Here is what he brought in, clearer than we had ever had some, and others for the first time—

AN EVENING AROUND EUROPE  
The Stockholm station in Sweden sends

us a program that is re-transmitted by six other Swedish stations. We picked up Motala, on 1,320 meters, 30 kw. They were having a program of Danish music and Danish lyrics. It came in clear and fine; and after this we moved on and got, for the first time, Kalundborg, near Copenhagen (Denmark), although it has only 7 kw. It also is a long-wave station, 1,153.8 meters. We never succeeded in understanding a word of their announcements, except the names of the selections, which followed faithfully the published list. We could hear, for instance, "Polka" by Britta, and "Galop" by Champagne.

Then the operator switched and gave us Koenigswusterhausen, just outside Berlin. That name is so terrible that it can't be missed in the announcements, so one always knows that particular German station. In fact, we know just enough German to find our way about Frankfurt, Langenberg, etc. We picked them up that night between nine and ten when dance music was on.

The evening was not over, however, before Warsaw in Poland also gave us a dance program, and Hilversum in Holland had a symphony orchestra whose selections we could follow. Our next station, rather late in the evening, was a surprise. In good English, a voice announced several fox-trots, with no station announcement at all—just "fox-trot," and then the name. I insisted it was Daventry (England). The operator declared it couldn't be an English station on a Sunday night, and examination of the programs proved him right. They all had "religious services."

Then, after the third or fourth dance, as the applause died out, a voice began to talk Danish and there we were back in Kalundborg. That's one of the difficulties. All dance music on the continent has English titles; but as the announcers usually have curious accents one can guess where one is at. Not so at Kalundborg, where the announcement was well read.

Late in the evening we dropped down into Spain, where Madrid, a short-wave station of 375 meters, and only 1.5 kw. power



A German orchestra at the "Noreg" station. The decorations of this studio have a distinct mediævalistic tendency; for example, the light fixtures and conductor's stand.

\*Director of English Broadcasting of the Radio Institute of the Sorbonne, Paris, France

# Principal European Broadcast Studios



The stations listed in the accompanying article, except a few outside the area shown here, are indicated on the map above by crosses; those encircled represent the principal and highest-powered transmitters in the respective countries of Europe—each of which, excepting Greece—has at least one. The key to their numbers follows:

- |                    |                  |                 |                |                |                |
|--------------------|------------------|-----------------|----------------|----------------|----------------|
| (1) Angora         | (10) Saventry    | (19) Kalumborg  | (28) Lyons     | (37) Oslo      | (46) Sofia     |
| (2) Barcelona      | (11) Dublin      | (20) Karlsborg  | (29) Madrid    | (38) Paris     | (47) Stockholm |
| (3) Berlin         | (12) Edinburgh   | (21) Katowice   | (30) Milan     | (39) Prague    | (48) Toulouse  |
| (4) Bern           | (13) Frankfurt   | (22) Koeno      | (31) Minsk     | (40) Rabat     | (49) Vienna    |
| (5) Brussels       | (14) Geneva      | (23) Langenborg | (32) Moscow    | (41) Reval     | (50) Warsaw    |
| (6) Bucharest      | (15) Hamburg     | (24) Liviste    | (33) Havana    | (42) Reykjavik | (51) Zagreb    |
| (7) Budapest       | (16) Helsinki    | (25) Leningrad  | (34) Marseh    | (43) Riga      |                |
| (8) Constantinople | (17) Helsingfors | (26) Lisbon     | (35) Naples    | (44) Rome      |                |
| (9) Copenhagen     | (18) Helsinki    | (27) London     | (36) Nuremberg | (45) Salamanca |                |
- (The wavelength of Lahti, above Helsingfors, is not yet given.)

# Two New European Radio Transmitters

## FINLAND'S BIG NEW STATION

Right: The towers of the new broadcast station at Lahti, which has just been completed. The transmitter is a duplicate of the new one at Zeesen, Germany, and shares with it the distinction of being the most powerful in Europe. The steel masts are 492 feet high.

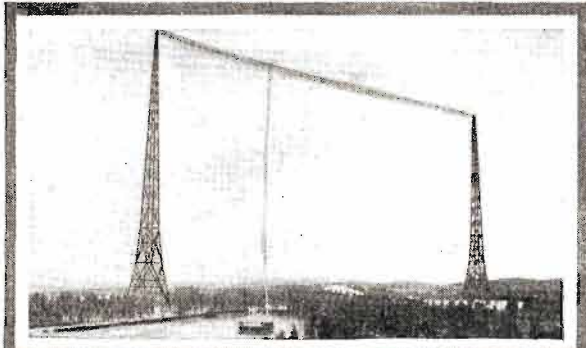

## THE LAND OF THE THOUSAND LAKES GOES IN FOR SUPERPOWER

Below, the transmitter of the Lahti station; the large handwheels in the foreground operate variometers in the tuning circuits. The studios are located sixty miles away in Helsinki (Helsingfors) capital of Finland as well as the old transmitter, which is of low power. The input of the new one is 120 kw.

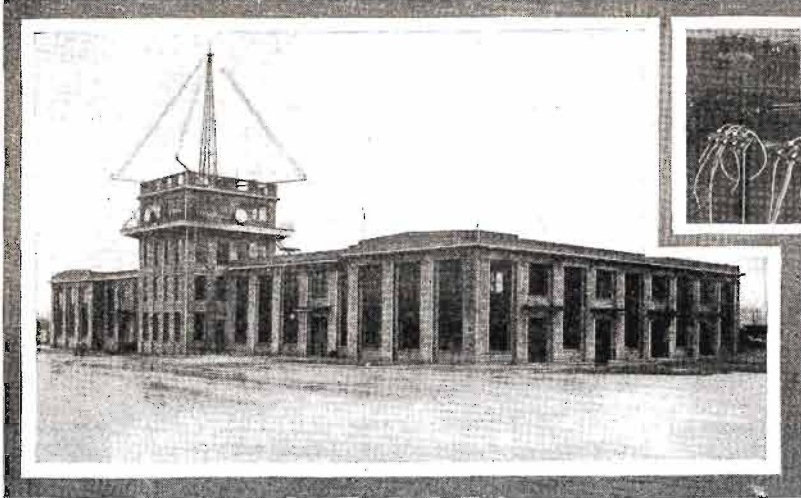
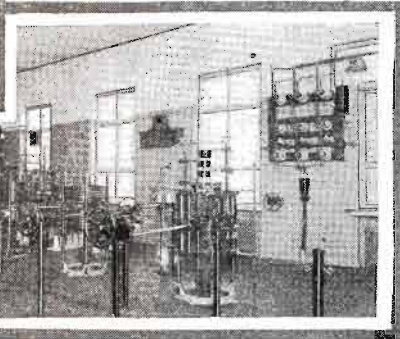

## AIR TRAFFIC POLICE USE RADIO

Below, the four 100-foot masts of the London Terminal Airport at Croydon, England. Each carries a cage aerial.

## RADIO BEACON FOR BRITISH FLYERS

Above, the Croydon Aerodrome terminal buildings with the control tower. On this is a 54-foot mast which supports a Marconi Bellini-Tosi aerial, composed of two triangular loops at right angles. This guides aircraft in a direct path toward the tower in any weather.

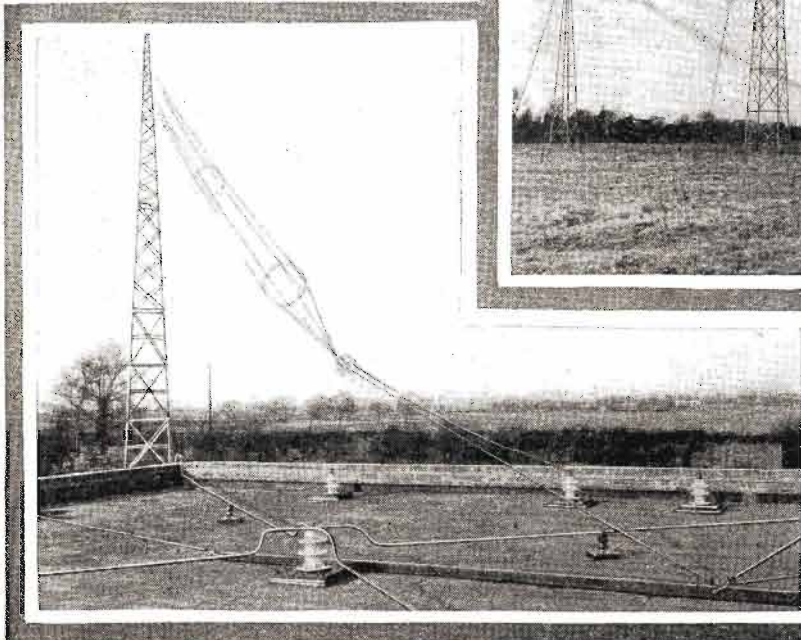
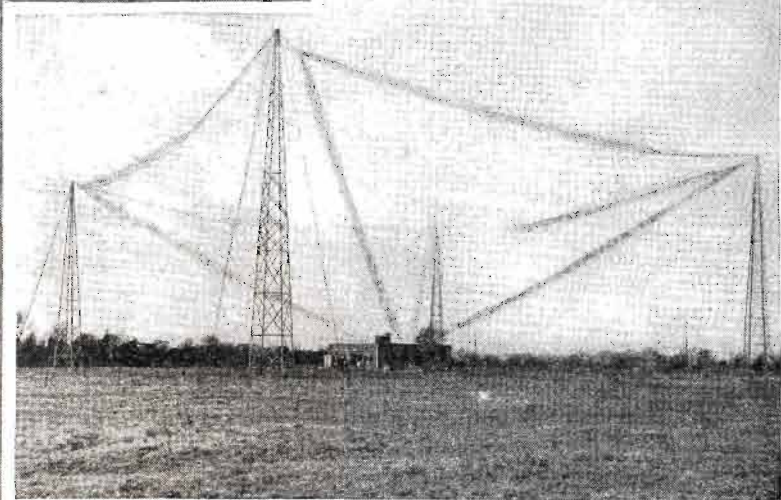

## THE "STOP-AND-GO" INDICATOR

The four masts of the Croydon installation, above, are spaced at the corners of a 250-foot square. At the left, one of the cage aerials with its lead-in through the roof of the transmitter building. The copper tubes connecting to the station's elaborate ground system. Other aerials are connected to suitable points on the other terminal buildings, above at the left. This elaborate equipment is used to police the airways and to guide and dispatch aircraft, on a regular traffic schedule.

was sending out an operetta based on "Twenty Thousand Leagues under the Sea!" Had it been a week-night, we would have ended as usual with the ringing of "Big Ben" in London, with which the London and Daventry stations sound the midnight hour.

#### RADIO'S TOWER OF BABEL

It goes without saying that one doesn't understand the speeches to which one listens. Anyone knows French, Italian, German, or Spanish when he hears it (*In Europe—Error*) and recognizes city names in those tongues. We work with a chart on which positions of cities in relation to Paris are indicated, as does any one with a loop receiver; and, for the rest, wavelengths, strength, and programs are the guides.



A corner of the studio in the Stuttgart (Germany) broadcast station. Notice the microphone mounted on its tripod in the corner.

When the operator is playing around at random he may get all sorts of surprises, as in the case of the Kalundborg announcements in English, and so be thrown completely off his reckoning. For example, "Radio-Oslo" (Norway) and Daventry (England) give courses in French; Budapest (Hungary) gives a German literary talk; "Radio-Geneva" (Switzerland) has talks in Esperanto; Prague (Czechoslovakia) has its elementary German lesson; Kovno (Lithuania), broadcasts in French as well as in Lithuanian; Berne (Switzerland) announces in French and German; "Le Petit Parisien" (Paris) announces in French and English; and we at the Sorbonne broadcast a quarter-hour daily completely in English; Huizen, in Holland, caps the list with a half-hour lesson in Latin! With the friendly chart lost and the newspaper mislaid, one is quite at sea frequently until a stray word comes in.

Strange things do happen. We were excited one afternoon when the operator found a new long-wave station. It was evidently Italian—a rich baritone sang "O Solo Mio" with real Italian sentiment—and, as our breasts heaved with exquisite pleasure on the last note, the announcer said in French, "This is the station of the

P.T.T. (Posts, Telephones, and Telegraphs) Paris. You have just heard "O Solo Mio," registered on a disc of the French Gramophone Company." One would think a government station would stay on its own wavelength, but the P.T.T., normally 458 meters, is emotional and always strays over into other fields.

Again one tunes in to the playing of the "Marseillaise" with which Radio-Paris always ends its programs; and, behold, it turns out to be a radio trio away up in Hilversum!

#### INDIVIDUAL STATION "TRADE MARKS"

Because of the inability of the European listeners to understand all the languages they traverse, many of the stations have adopted quaint signals, in addition to Morse code. I have already mentioned Daventry's broadcasting of the striking of "Big Ben," which occurs several times a day, and the "Marseillaise" at "Radio Paris." Copenhagen opens with three strokes on a gong, and closes with the Danish national hymn; Madrid (Spain) open with piano chords, and closes with the Spanish hymn; Barcelona (Spain) also ends with the national hymn and opens with the cathedral carillon. Between selections one has a metronome in Vienna (Austria); and in Budapest (Hungary) a signal on two notes, one higher than the other. Rome (Italy) opens with a harmonium accord, and closes with the "Marcia Reale." Kovno (Lithuania) strikes a gong between numbers, and Geneva opens with a long whistle, repeated three times.

I say they do these things; but rather they do them part of the time, with unfortunate irregularity, and so we have all the uncertainties, the rest of the time, of aviators forced down in an unknown territory!

But if one could really understand, what fun it would be to get the full international melange! In one week I found listed a Gaelic lesson in Dublin; a "Voyage with S.S. *Minerva* to the Mediterranean" from Oslo (Norway); a course in English literature in Vienna; "The Life and Works of

Stevenson" from Lyons, France; "Contemporary French Poetry" in Berlin; and the "Turkish Woman of Fifty Years Ago" from Denmark! Everybody's ideas about everybody else, and each in a different tongue!

#### EVER SOMETHING NEW

And, grace to the art of re-transmission, into what places, gay or select, as your fancy dictates, may you not go in a week, becoming in seven days a real cosmopolitan. You may dance in the Grand Hotel Royal of Stockholm; the Savoy of London; the Dance Palace of Saint-Sauveur in Brussels, Belgium; in a cafe in Hamburg, Germany; the Palace Hotel of Copenhagen; the Alcazar of gay Madrid; or the Fiaschetta Toscana of Milan (Italy). You may hear a concert by the Philharmonic in the concert hall of Prague, or in that of Amsterdam in Holland; or you may prefer the Salle de la Reformation in Geneva, or the Philharmonic Hall of Warsaw. If your taste runs to opera or operetta, whisk yourself away to the Theatre du Capitole in Toulouse, the Theatre Bellini in Naples, the Scala or the Theatre Lyrique in Milan, or the Royal Opera of Stockholm; or into the Municipal Opera in Riga (Latvia); or change to the annual revue of the Guignol Mourguet in Lyons. For the "highbrow" there is drama; such as "Los Galeotes," a four-act comedy in Radio-Barcelona, or "Sadko" by Rimsky-Korsakoff, at the Theatre National of Prague.

And, with all this traveling, no one looks through your baggage, you need not submit to the indignity of an insulting passport photo, and your visas never expire!

#### European Broadcast Stations

In the Order of Wavelengths (See Note at Bottom of List)

	Meters	Watts
Paris (Eiffel Tower), France	2635	20000
Lugby, Sweden	2400	1500
Kovno, Lithuania	2000	7000
Huizen, Netherlands	1965	7000
Angora, Turkey (Asia)	1806	20000

Position indicated on map by figures.

(Continued on page 1389)

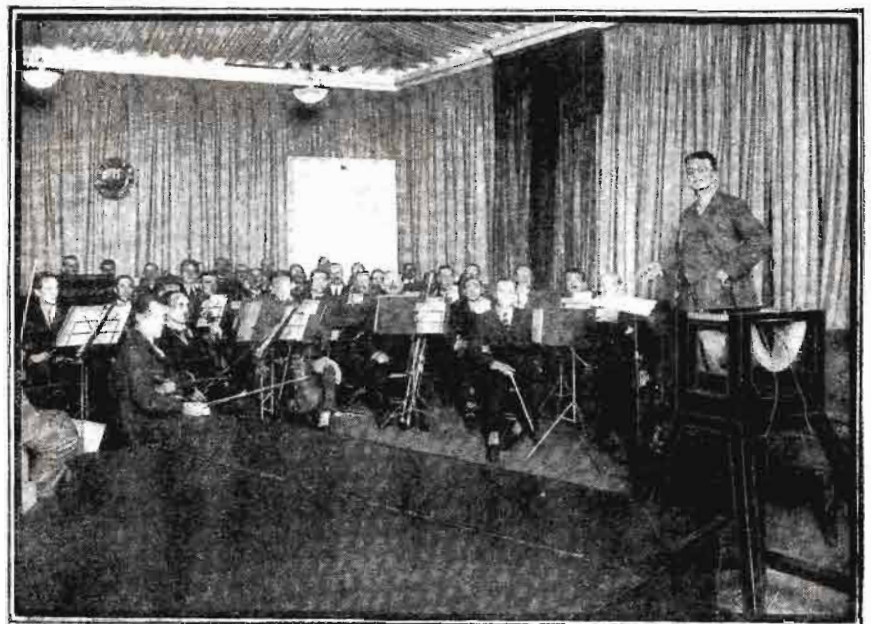

An English orchestra in the broadcast studio of 2LO, London, on the occasion of the rebroadcasting of that station through KDKA and WJZ. Notice the microphone at the right.

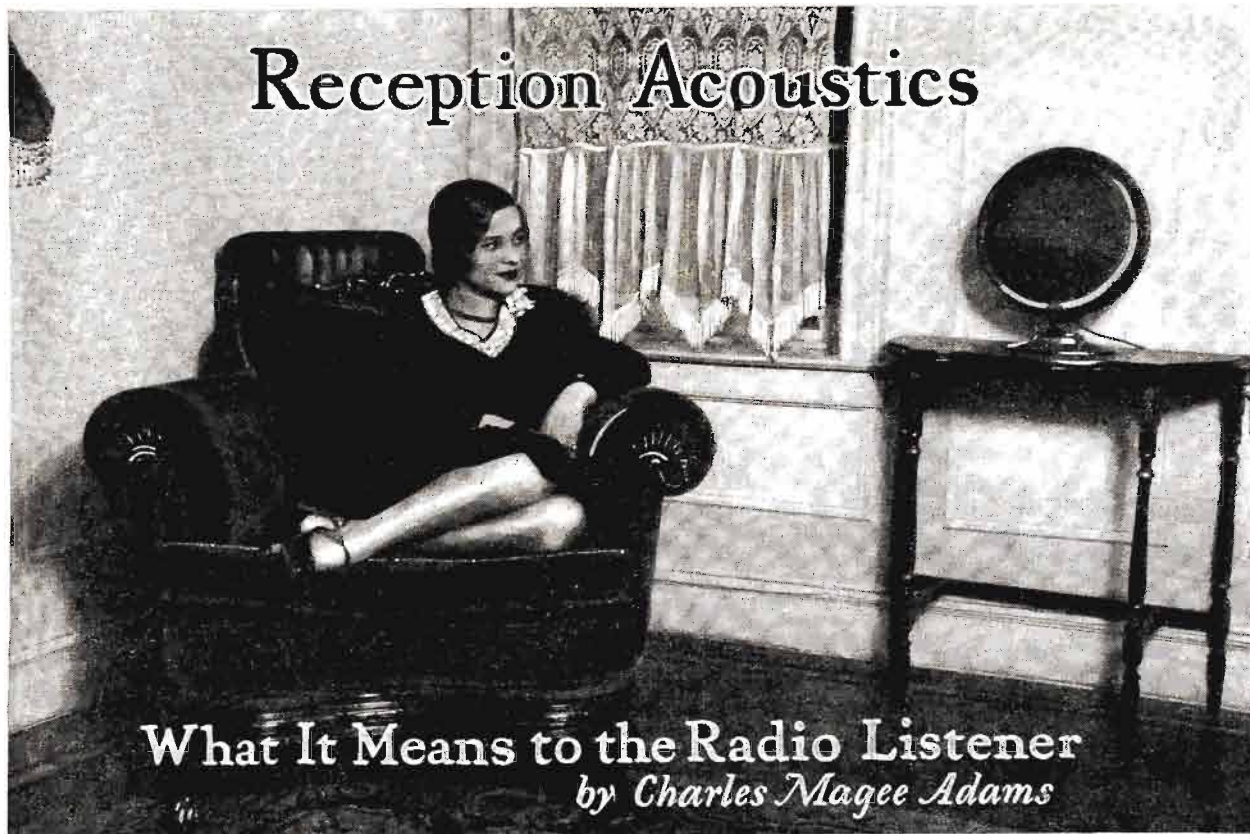

*A loud speaker placed on a small table, as shown above, will be on a level with the listener, and will therefore seem most natural to the ear.*

**I**N the attainment of tonal fidelity—one of the coveted goals toward which radio technicians have been striving since the inception of broadcasting—much has been said and done regarding such things as the improvement of studio acoustics, transmitter modulation, and receiver reproduction. But, possibly because of the attention focused on these three phases of the general problem, and probably because the remaining one is a matter for the individual listener to solve, little thought seems to have been given a fourth phase—that of reception acoustics. By this is meant what may be termed the “*tonal setting*” of the receiver’s reproducer, and a moment’s consideration will reveal its fundamental importance.

Thanks to improvements in pick-up acoustics and transmitter modulation, a signal with tonal characteristics of a high order can now be had from the better stations; and, through modern amplifier and loud-speaker design, this can be converted into an audible output whose fidelity, compared with the original music or speech, leaves surprisingly little to be desired. But, like a painting by one of the masters seen in a dingy frame or under poor light, the excellent results thus secured can easily be minimized by adverse acoustical conditions at the point of reception; and one prolific cause of these is the improper placing of the reproducer with respect to the room in which it is located.

#### DECORATION VS. HARMONY

From the standpoint of their installation, loud speakers may be classified in two types—built-in and separate. In the case of the first, because the speaker is an integral

part of the receiver, it is common practice to place the cabinet housing the whole at the point that will be most convenient for aerial and power-supply connections and secure the most pleasing results on the score of appearance. In the second, appearance is usually the dominant consideration, with convenience of connection to the receiver a minor factor. Instead, the location of the speaker in either case should be dictated first by acoustical considerations.

To be specific, the output of the speaker should not be directed across the breadth of a narrow room or, worst of all, into a corner; rather, let it be made to command the entire room, from either an end, or, still better, a corner. In order to do this it may be necessary to sacrifice convenience in connecting, where the speaker is built into the receiver, or appearance, in the case of a separate unit. But the superior results secured will make either sacrifice worth while.

With the position suggested, it will be found that the volume is practically uniform over the entire room, without dead spots, and (equally important for maximum enjoyment) there are no “flarebacks” or points of reflected-sound intensity, as when the speaker is directed into a corner or against a wall too nearby.

#### SOFTENING THE MUSIC

Second, the important matter of “damping.” It is common knowledge that the character of sound is materially affected, whether it is absorbed or reflected, by the surfaces against which it strikes. This is a vital factor in securing proper acoustics for an auditorium or any room designed for assembly purposes; but in the home it

is generally overlooked. Yet, for the best tonal results from the highly-developed musical instrument that a modern radio receiver is, it must be given serious consideration.

“Damping” should be moderate over the entire room, and preferably greatest at a point opposite the loud speaker. Broken surfaces and soft materials—rugs, hangings, upholstery—“damp” sound; while flat, hard surfaces of large area, such as bare walls, reflect it. So the application of the principle involved should be easily seen.

In a majority of cases, once the speaker has been properly placed, no change in furnishings for “damping” purposes will be required; but in some a little intelligent rearrangement will be needed.

Many living rooms of the type found in new homes are much under-damped, because of the large area of walls and bare floor. The result is a barrel-like booming; not an actual echo, yet a reverberation robbing the tone of its rightful fidelity. The remedy usually consists of shifting some large piece of upholstered furniture to a point opposite the speaker, or placing a soft hanging or even a rug at this location. Often this can be done without marring the symmetry of the room.

On the other hand, many apartment living-rooms are heavily over-damped, on account of their small size and the consequent crowding of furniture. The remedy—rearranging or sacrificing furnishings—may be out of the question. But the fact that the room is over-damped will explain a lack of fidelity otherwise charged to the receiver.

Damping, too, does not depend solely on furnishings. For example, if a room is crowded by a party of listeners, it will be found that volume is materially reduced



and that the tone lacks life, simply through the absorptive characteristics of the guests' bodies; just as the acoustics of an auditorium is altered when it is filled with a capacity audience. Something of the same effect will be noted also when doors and windows are opened; the air spaces thus provided acting sometimes as dampers and sometimes as resonators for the sound.

**TYPES OF SPEAKERS**

But the acoustical setting of the loud speaker itself is as important for best results as the general acoustics of the room in which it is operated.

For example, in the case of built-in cones not enclosed at the rear by a partition, it is necessary for acoustical reasons to keep the space behind them filled. It is generally designed to accommodate batteries or power units, but many fans make a practice of removing this equipment or replacing it with apparatus of less bulk. Whenever this is done, the space should be occupied by some object whose size and hardness approximates that of the original equipment, such as discarded batteries. They will serve an important acoustical purpose, if no electrical one. The cabinet and speaker were designed with their presence in mind, and removing them often causes a "tinny" hollowness or reverberation due to the unintended vacant space.

There are some details also worth considering in choosing the location for a separate cone speaker. A speaker of the single-cone type will generally be found to give best results when placed diagonally across a corner. The air space behind it is just sufficient to permit fullness of tone, and the spreading of the walls tends to distribute the sound over the room with pleasing uniformity.

Should such a location not prove practicable, placing the speaker against the wall will give satisfactory results, provided a few inches of intervening space is left:

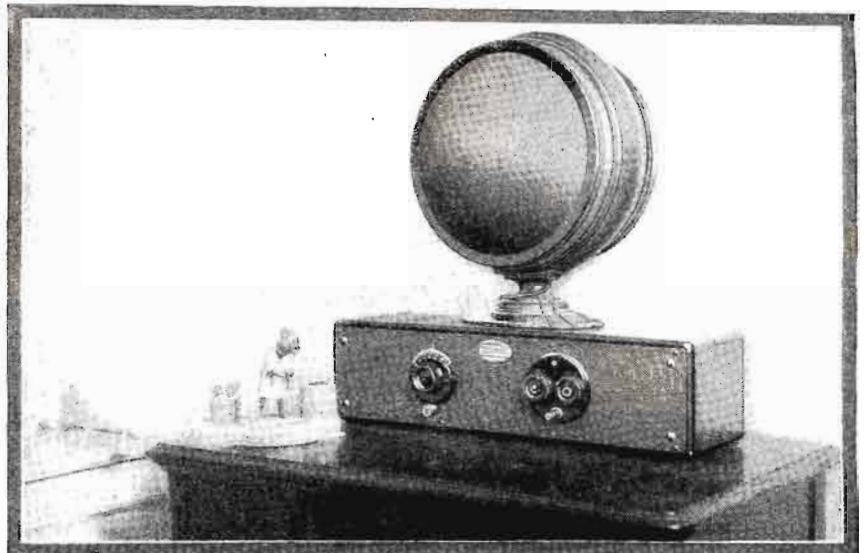

*A decidedly poor way of placing the loud speaker. In this position it causes very annoying "microphonic" noises, which will disappear only when the speaker is removed from the top of the set or from the table altogether.*

otherwise, the tone will prove shallow or muffled. A few minutes' experiment, however, will disclose the correct placement.

Height of the speaker's position is another detail generally overlooked, or decided on the basis of some consideration other than acoustical. Appearance may, of course, dictate a different choice; but, if the best tonal results are desired, it will be found that placing the speaker at the level of the head while sitting is most desirable. This is particularly advantageous on weak signals and, should no suitable table or stand be available, a small shelf can easily be constructed.

Some single-cone speakers give greater volume when mounted with the concave side

out: that is, with the apex of the cone turned away from the listener. Many built-in reproducers are installed after such a fashion, not only because of the greater volume, but especially for mechanical protection. However, it must be stated that mounting in this manner often results in a sharpness and metallic quality which offsets the gain in volume, when full fidelity is desired.

It should not be necessary to add that a speaker should never be placed ON a receiver cabinet. But many listeners still seem unaware that this causes the microphonic "tube-noise" which they find so objectionable.

*(Continued on page 1365)*

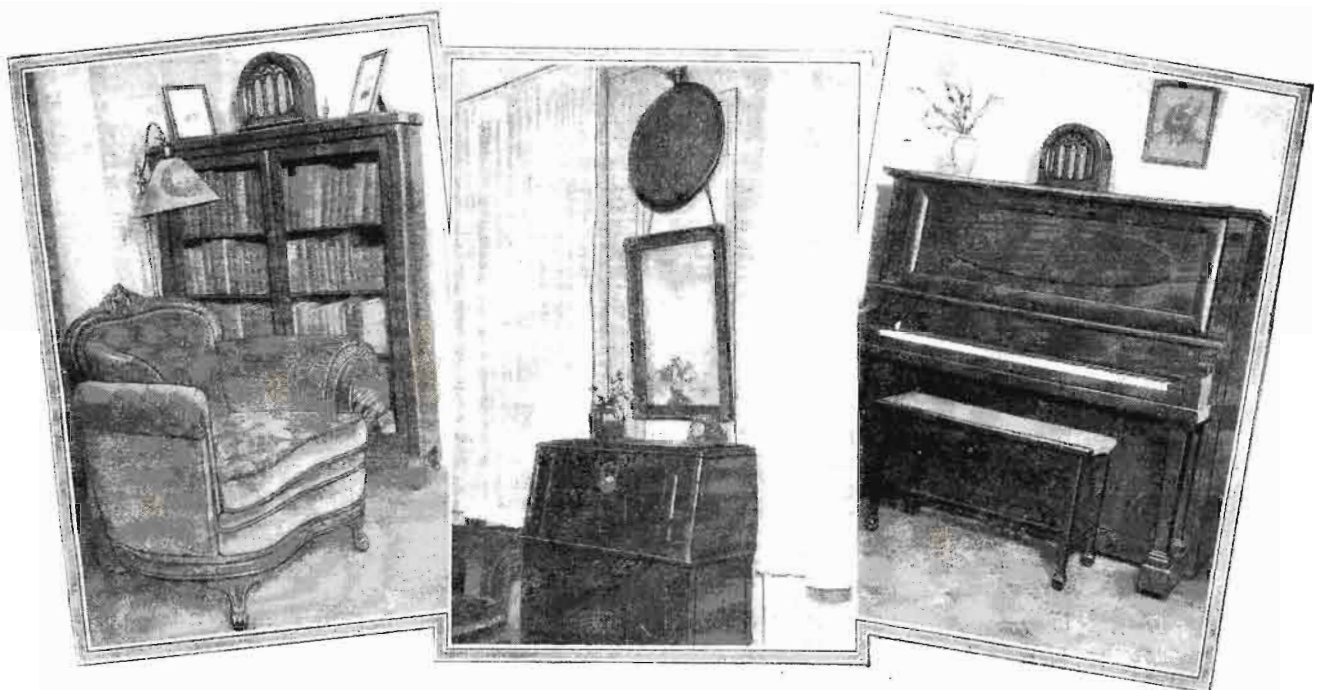

*Left: A small loud speaker may be placed advantageously on the top of a bookcase in a corner, where it will both look and sound well. Center: A good way of disposing of a cone when*

*there is no place for it to stand on its own base. Right: The piano makes a good support for the loud speaker, if no lower piece of furniture is conveniently available for this purpose.*

# How Many Stations on One Wavelength?

A Discussion of the Problem of Enabling More Than One Station to Operate on the Same Wavelength in a Program Network

By J. H. Barron, Jr.

THE broadcasting of chain programs has now increased to such a great extent that many listeners, particularly in the Middle West, complain of being able to receive no others. This has brought up to many the question, why not have each of the stations broadcasting the chain program operate on the same wavelength or frequency so that other programs could be broadcast by other stations without interference for those listeners who do not care to hear the program being broadcast by a chain of stations?

There are two important technical problems to be solved before this is practicable. First, it will be necessary that each broadcast station be adjusted to and maintained on exactly the same frequency; and second, it will be necessary that each transmitter utilize exactly the same sound quality in its modulation.

The program from the studio where the actual rendition is taking place is transmitted over telephone lines to the various broadcast stations comprising the chain, as described in the previous issue of *RADIO NEWS*. Because of various electrical effects encountered while passing over the telephone lines, the audio current derived from the original sound, when arriving at various stations, does not necessarily contain exactly the same frequencies or tones. Certain tones are accentuated or reduced, on account of the varying effects encountered. To increase the reduced frequencies and properly reduce the accentuated ones, so that the sound will be restored to its approximate original quality, requires that

the telephone lines be connected to a device known as an "equalizer," which, by proper adjustment, accomplishes the desired result. As there are differences in equipment of the same or different makes used, it is not likely that exactly the same frequency as that originating in the studio will be produced; it is very likely to be of a slightly higher or lower pitch. After being equalized, the sound-currents are then amplified and passed on to the modulating system, which is that part of the transmitter where the audio waves are superimposed upon or "modulate" the generated waves of radio frequency. In this process further changes occur, and are usually different at each station. This causes a still greater dissimilarity of tone quality between the program broadcast by the individual station and that originally heard at the studio.

The result is that at each station the transmitted program will have a pitch slightly higher or lower than the original one. This in itself is not of great importance, as the distortion or change is usually not sufficient in amount to be objectionable to the ear.

## STATIONS "OUT OF TUNE"

However, if a number of stations, all within range of the receiver, were broadcasting a given program on exactly the same fundamental wavelength, the result would be comparable to the effect produced if each instrument of the same type were tuned slightly different. For example, if there were three violins, each of which was

sounding respectively the notes "C," "D," and "E," the result would be a dissonance. If there were three stations within range of the receiver and the note produced at each differed slightly, the effect would be comparable. These three notes, arriving at the same receiver, would clash. It is, of course, not probable that the distortion would be so great as instanced above; but some clashing or discordance would be noticed if any varying distortion of the original sounds existed in the programs broadcast at the several stations.

An example of this effect has probably been encountered by many listeners. When receiving conditions permit, it is possible to listen to one of the stations broadcasting a chain program, and then quickly to change the controls, so that the same program is received from another station. A difference will often be noted; in some cases, certain instruments in an orchestra will be more plainly heard from one station than from the other. This will usually be especially noted in the case of the bass instruments, such as the drum, bass viol, etc.

The phenomenon of *fading* also tends to increase the difficulties incident to the problem. What is known as "selective fading" also introduces great distortion; this is due to the fact that some of the transmitted frequencies fade more or less than the other frequencies which make up the particular combination of tones transmitted at the time. This has been noted by most listeners. It is mostly apparent when receiving

(Continued on page 1370)

*Chain programs may be of the highest quality; but to be greeted too often by the same number from top to bottom of the tuning scale produces a feeling of resentment on the part of listeners—especially those who are not favored by good independent programs from local stations—which has been reflected in radio legislation.*



# A Britisher Chats on Radio



In Which a Wallop or Two Are Taken At the B. B. C. and Other Radio Institutions More or Less International In Scope



By E. Blake

I AM aiming to touch a number of sensitive spots on the organism of the American radio public this month. We shall then ache in unison—and what closer bonds can exist than those uniting souls which have suffered together? (*End of sob stuff*—America. I thank thee for the term “sob stuff;” nothing in *real* English packs such punch in this particular line of descriptive writing.) To resume, I aim also to strike several responsive notes, to this end; namely, that while I am writing about the English Bill Smith of London, you will be thinking of Ed. van Stuyvesant or Al. Somebody of New York or what-not. If I am lucky and inspired we shall then chuckle in chorus—and that’s the way folk were meant to do. (*End of prospectus.*)

A mau-eater’s-size growl is rumbling along the ranks of British listeners. We are, proverbially, the World’s Greatest Grouchers; firstly, we cuss any kind of government we vote into power; secondly, we growl at the income tax—not without reason, O bloated buyers of millions of oddomobiles, radio sets with tubes uncounted, and numberless first-grade, double-damped Everglades acres—not without reason, when you consider that, of every dollar Mr. Gernsback donates in return for these relics of an effete English literature, the British Treasury requires me to cough

up twenty cents. And we growl at the railroads. More glory is counted unto the commuter who basely cheats a railroad out of a dime than unto the prince of financiers who nobly swindles a whole community out of a billion dollars. The railroads and the income-tax collectors are, evilly, considered fair marks for anyone’s shotgun. There’s a fine text for that “Big Bill” man in the town where they eliminate men and cattle so freely.

But our Royal British Broadcasting Corporation has provided us with the snarl of a century; its programmes are an unending source of spleen. Not without reason, O people of a thousand radio stations and but slightly-fettered competition. Here is no competition whatever and we have to feed our ears on whatever the B.B.C. likes to sling into the trough, or turn elsewhere.

## ALAS! ALAS FOR ENGLAND

Now, the two greatest bugs in the ointment are “chamber music,” and “talks.” No doubt you call them by different names; but I reckon that the stings they supply are equally poignant on either side of the water Lindbergh flew over. (That’s a name to conjure with here, believe me! I was so “hot up”—again I thank thee, Columbia!—over Lindbergh that in my excitement and confusion I mailed him an offer of marriage! No reply up to date of this writing.

Still, it seemed the right thing—I could not send a man like him soap or suspenders.)

This “chamber music!” We get it several times a week; though once it begins it goes on for a month. They collect in the studio a depressed pianist, a violinist with weight on his mind (if any) and a piccolo-pumper disappointed in love. Then they turn down the lights and go home. The result is chamber music. It works out on the average as a sort of bleached negro spiritual, double-distilled and a hundred miles long; it is played by people with no hope in this life and a dread of the world to come. Stated in terms of physics, it is the wail of a stuck pig multiplied by 17653, plus the music of a railroad freight-depot, plus a thousand cats with their rudders caught in a steel-plate rolling plant. I hope you recognize it. It is signed mostly by Bach, Bite, and Bumperkopfernickel and all that gang.

“Talks!” Now, our theory is to the effect that, when a man has sweated all day in a city office, trying to revive the faded blossoms of British commerce, he needs a radio talk! If he needs any talk at all, and not profound silence, he needs a talk entitled, “How I fought the Pawnees in ‘64;” or “When I went over Niagara in a barrel and green-striped slumber-wear.” Or again,

(Continued on page 1371)

“... the feat of an ingenious Noisy Boy, who hitched seven power tubes to a loud speaker and blew a churchwarden through the window of a cocktail-parlor, where he lauded at the feet of the Senior Deacon.”

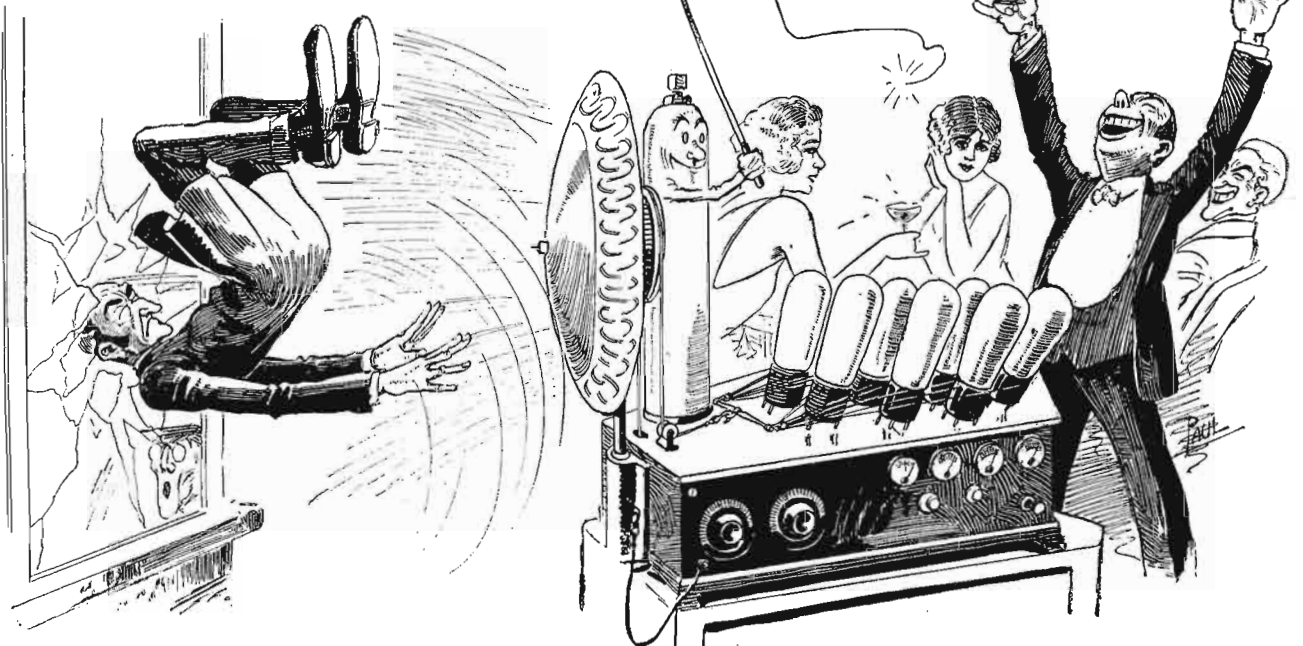

# A Real Radio Hound

How "Mike" Aids His Master by  
Furnishing Real Barks During  
Certain Musical Selections

By Charles Magee Adams

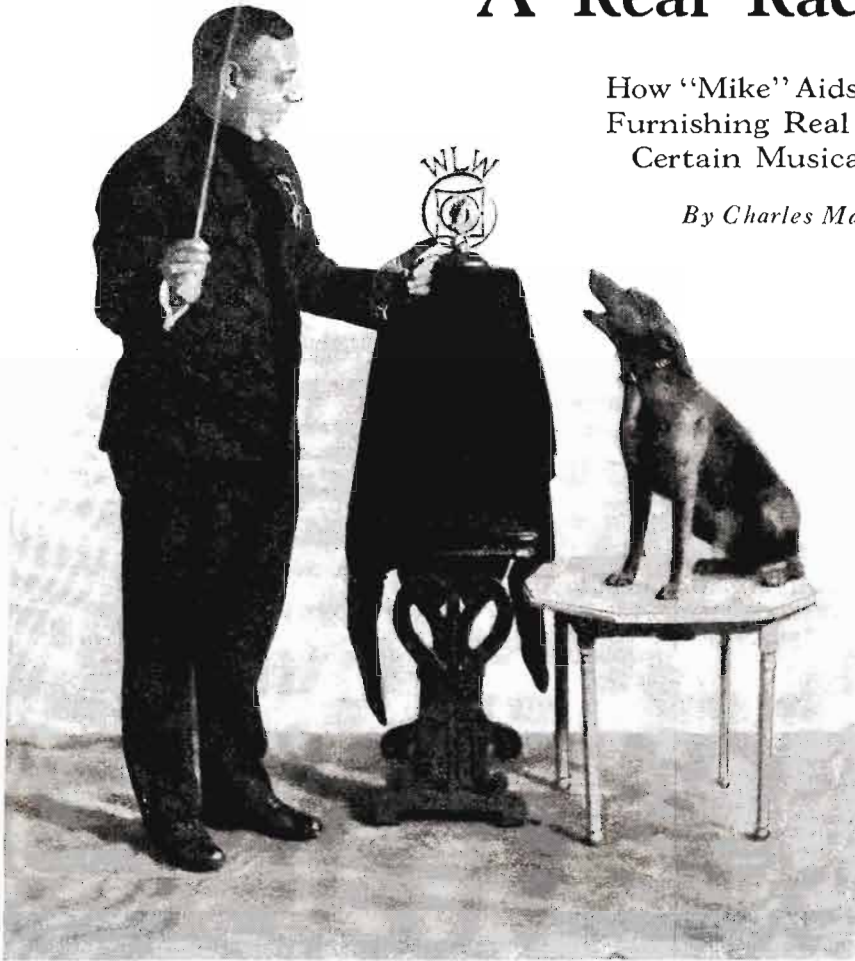

J. Henry Fillmore, Jr., and Mike, the "radio hound."

EVERYONE is, of course, familiar with the term "radio hound;" in the vernacular, it means a radio fan, one who is a devotee of or enthusiastic about broadcasting. But few other people, if any, can use the term as literally as does J. Henry Fillmore, Jr., of Cincinnati; for he is the owner of a dog which appears before the microphone not only during regular programs, but as a trained member of a band.

Mr. Fillmore, as musically-informed readers will no doubt recall, is both a well-known band director and a composer. For many years he was the leader of the Cincinnati Shrine Band, which carried off honors at the annual Conclaves; and he is now the leader of Fillmore's Band, a Cincinnati organization which rates high in the musical world. As a composer, Mr. Fillmore has to his credit such marches as "Men of Ohio" and "Golden Friendships," which are included in the repertoires of the country's leading bands and orchestras, besides many other instrumental selections and songs that have attained wide popularity.

Among his compositions is a descriptive piece entitled "The Whistling Farmer Boy," which depicts, in colorful fashion, early morning on a farm; the boy of the family rising at daybreak and, accompanied by his loyal canine friend, making the rounds of the barns and bringing in the cows. The

score calls for the repeated barking of a dog by way of added realism; and during its early presentations Mr. Fillmore used a "trap" for this purpose. Then "Mike" stepped into the picture.

## THE TWO "MIKES"

Yes, his name is Mike, an aptly-appropriate monicker for a dog who broadcasts. Three years old, and "just hound," is the way Mr. Fillmore describes him.

"He wasn't trained with any idea of using him over the radio," his owner explained, recounting Mike's first appearance before a microphone. "We'd made a particular pet of him at home and, among other things, I'd taught him to bark whenever I pointed my finger at him. He always went with me to rehearsals, and one night while I was preparing for a concert to be given at WSAI it just occurred to me that I might use Mike instead of a trap for the barking in "The Whistling Farmer Boy," with effects that would be more lifelike. I tried him, and he barked not only where the score called for barking, but exactly in time with the band."

"You used no other means to make Mike bark?" the writer asked, after hearing what proved to be a most realistic performance before the microphone.

"That's all," Mr. Fillmore replied. "Before the number started I placed him up among the boys where he'd be within easy

range of the microphone, and a few measures before he was to come in I looked at him. Then, at the right moment I simply pointed my finger at him. He started barking and kept on till I lowered my finger again."

But, like many broadcasting artists among the *genus homo*, Mike has his quirks of temperament that add interesting complications to his performance.

"For one thing, I don't usually employ a baton to direct the number in which I use him," Mr. Fillmore said, smiling indulgently down at his remarkable animal. "He's never been beaten. Yet he simply can't stand the sight of a stick in anyone's hand. I suppose the fear of one has been bred into him through generations of his ancestors."

"Recently, however, I have found that he now works equally well while I am holding a baton, as shown in the photograph taken before the WLW microphone. Also, he has taken to the stage and is even better on it than in front of the microphone. After the usual explanation regarding "The Whistling Farmer Boy," I whistle and call him. He trots out, jumps on his chair, and away we go."

## KEEPING TIME

And Mike demonstrates another canine peculiarity that should have particular appeal for musicians.

"The accepted way of directing is, of course, always to start off on the down-beat," Mr. Fillmore explained. "But maybe you've noticed that a dog, and especially a hound, throws up his head when he barks. So I've found I have to start off on the up-beat in the passages where Mike is to bark. Otherwise I cross him and he comes in too late."

As if it were not enough to have used a dog as a regular member of a band appearing before the microphone, Mike's owner relates an experience which demonstrates the fidelity of modern broadcasting in striking fashion.

On the Sunday following his dog's debut as a radio artist, Mr. Fillmore went to a small town on the Ohio river above Cincinnati to meet some friends who had come there by houseboat. While crossing on the ferry, a native of the town was attracted by Mike.

"What kind of a dog is that?" he inquired, after making friends with the animal.

"A radio hound," Mr. Fillmore replied, smiling.

"You mean the one we heard with Fillmore's band at WSAI the other night?" the stranger demanded.

Mr. Fillmore nodded. But the other was not convinced. "You're trying to kid me," he charged. "That was a trained dog."

For answer the band director pointed his finger at Mike, whistling the proper passage.  
(Continued on page 1381)

# Shoppers Should Beware of the Radio "Gyp"

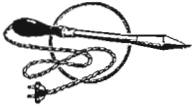

The Vicious Selling Schemes Employed by a Philadelphia Radio Retailer to Lure Victims Into the Store by "Bait" Window Advertising

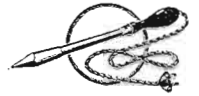

**"VICIOUS"** is the word which the Better Business Bureau advisedly selects to describe such practices as those described in this article; and RADIO NEWS will take vigorous leadership in a movement to put retail radio trade on such a basis that it may command the fullest of public confidence, which has been too often undermined by methods which are shady and, in extreme cases like this, absolutely dishonest. The co-operation of our readers is asked to insure thorough publicity for tricky tradesmen, and manufacturers as well.

If you have met with dishonesty in the purchase of radio equipment, let us have the facts for suitable investigation. If you receive exaggerated or misleading advertising matter send it to this office, in order that it may be followed up. Laboratory tests will be applied to material for which false claims are made, and the results published in a series of articles.—EDITOR.

EVERY large industry has always its parasites. Among those of the radio industry are certain small retail stores which foist upon an unsuspecting lay public inferior merchandise at a price out of all proportion to the value of the goods. The results of such practices are twofold: First, the purchaser of the articles wastes his money and fails to get the results to which he is entitled; and secondly, they destroy the faith and good-will of the public for the industry as a whole, and consequently impair the progress of radio.

The Better Business Bureau, an organization devoted to hunting out such cases as the one outlined in this article and giving them the proper publicity, received numerous complaints about the Parker Radio Company of Philadelphia. This company's apparent motto is: "Drag 'em in and sell 'em something they don't ask for." The various examples described below in the report of the Better Business Bureau shows just how this store was operated.

### THE BUREAU'S INVESTIGATION

"The Parker Radio Company, with stores at 203 and 625 Market Street, is indulging in selling practices which are a menace to the integrity of Philadelphia retailing. Buyers are lured into the stores through the medium of bait advertising. Their attention is diverted from the legitimate articles advertised at exceptionally low prices, to other merchandise. Disparaging statements are freely employed against many nationally-known articles, in this attempt to dispose of certain other products. Dissatisfied customers are met with high-handed insolence.

"Many complaints have been received and the Better Business Bureau has developed information by sending its own shoppers to



these stores to ascertain the methods employed. The management of the company has been informed of these matters. Despite this, there has been no appreciable change in the situation. The public is, therefore, entitled to know the facts."

### "KNOCK, KNOCK, KNOCK"

"According to the dictionary, 'bait' is anything used on a hook, or in a snare, trap or the like, to allure; any substance used as a lure in catching fish or animals. This definition affords an easy method of explaining 'bait' advertising.

"After entering the store, the prospective purchaser encounters a well-organized selling scheme. The essential part of this plan is to 'knock' nationally-known articles which



A close-up of the windows of the store shown above. Nationally-known merchandise at bargain prices tempts the buyer in; but "try and out it!"

are used as 'bait.' The store rarely carries a stock of these widely-advertised items which  
(Continued on page 1387)

# Radio Takes Over the Geography Class



A Consideration of the Shape of Our Earth and Its Effect on Radio Reception--Also of a Plan For Studying These Things on a Large Scale

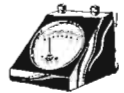

By C. P. Mason

PERHAPS the best teacher of geography that any of us have known is War; but he keeps a dear school. Somewhat more kindly an instructor is Radio, who reserves her brightest smiles for the DX listener. How many fans have learned more about unsuspected localities in the United States, by a short course in midnight listening, than a week on a desert island with the Postal Guide would have yielded them.

But it is a deaf ear or a poor phone that does not occasionally gather in something beyond the Rim. To how many has it seemed like the discovery of a new continent, when Port au Prince or Mexico City spoke forth clearly in French or Spanish? And, as for those favored ones with priceless location who have heard Lima and Tokio and even Sydney, what more in the way of a thrill has radio to offer until the television motor starts to spin?

This, of course, refers merely to the listener; not to the "ham," who has the proud privilege of talking back to EG and SC and AJ and OZ and the rest of the alphabet in his own picturesque slangage. He is in the advanced course in geography; his wall is papered with cards from every continent but Antarctica, and now he has hopes of working that, since the announcement of the Byrd expedition. His map of the world is filled with thumbtacks and lined with bright-colored string; he covers a tablet with calculations as to

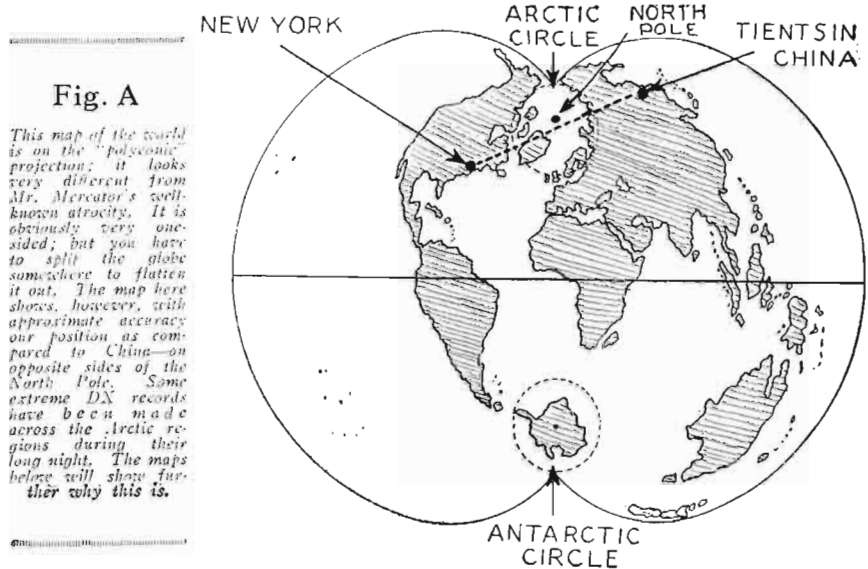

Fig. A

This map of the world is on the "polyconic" projection; it looks very different from Mr. Mercator's well-known atrocity. It is obviously very one-sided; but you have to split the globe somewhere to flatten it out. The map here shows, however, with approximate accuracy our position as compared to China—an opposite sides of the North Pole. Some extreme DX records have been made across the Arctic regions during their long night. The maps below will show further why this is.

whether he chewed the fat over a mere 10,000 miles, or "the long way round"—a handsome 15,000. Comforting thought!

### THE WORLD'S BIGGEST LIAR

When we come to consider the problems involved in the measurement of radio reception over distances such as these, we begin to realize the untruthful nature of the beast with whom the map-makers have

fought so long and unsuccessfully. To the three degrees of liars—ordinary liars, infernal liars, and statisticians—must be added a fourth: the map of the world.

Have you one of those nice, regular maps on "Mercator's projection," with the meridians of longitude running from top to bottom, spaced precisely even from Greenland to the Antarctic and at right angles to all the "parallels" of latitude? We are

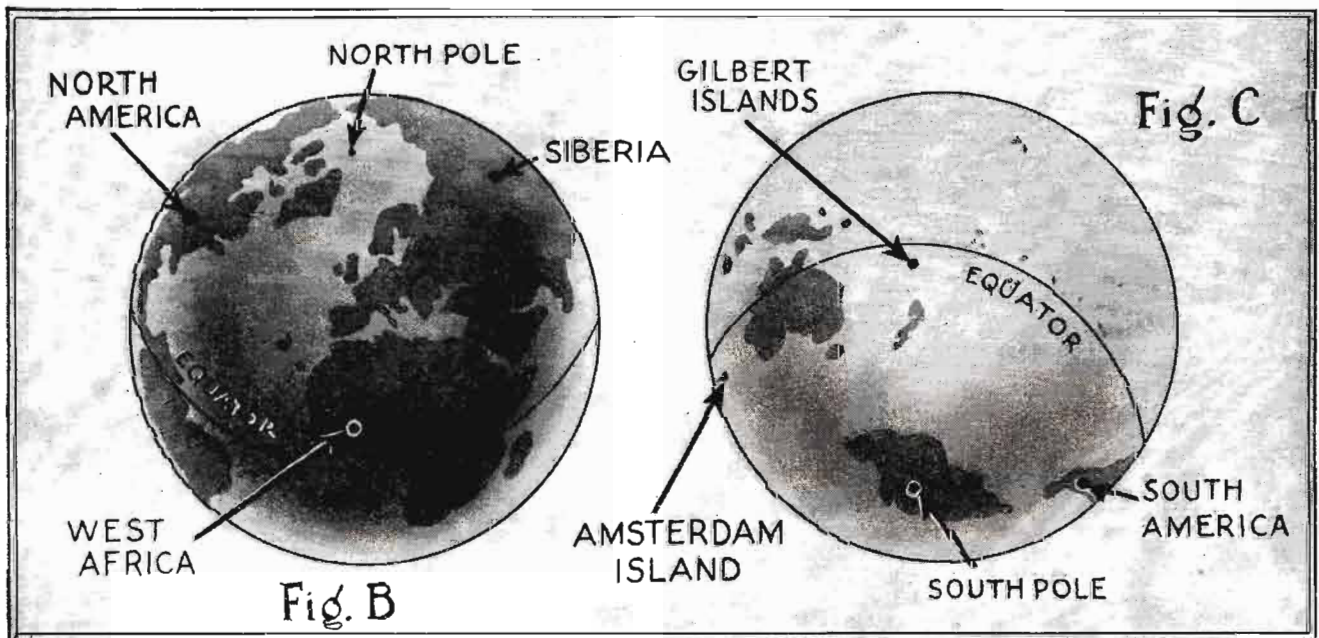

Fig. B

Fig. C

At midnight (Greenwich time) on December 22nd the "dark" half of the world in Fig. B is dark, the "sunlit" half in Fig. C in sunlight; while the conditions are reversed at noon six

months later. The places marked—beside the Poles—are approximately the sites for the radio research stations suggested in this article for the further study of wave propagation.

looking right now at a nice pink-and-blue-one—Uncle Sam's "Time Zone Chart of the World." There it hangs—and lies! Greenland is as big as South America—or would he if the map-maker hadn't given up, at 800 miles from the pole, in sheer disgust at the effrontery of his creation. (See Radio News for March, 1928, for a map of this kind.)

There is China, due west of us in the only possible straight line, 165 degrees of longitude. So, if any of us pick up XOL, Tientsin, and recall from our hazy school-days, "One degree, 70 miles," we shall announce that we have covered 10,550 miles—and write the editor about it. Perhaps some cantankerous critic of superior knowledge will point out that a degree, on our parallel, is only about 54 miles. Very well; the map will bear us out in claiming 8900 miles, then. Nevertheless, it is only about 3,500 from here to the North Pole, and as much more down on the other side to China. (China is nearly due north of us, and *we of China.*) So it can't be over 7,000 miles, the map to the contrary. Take a look at Fig. A!

"But," you say indignantly, "You can't go to the North Pole and down to China—unless you can borrow an airship."

"True indeed, Mr. DX Fan. We can't—but radio does!"

A SESSION WITH THE GLOBE

To measure long distances on the earth, you can't use a map; you must have a globe. Take a sheet of paper and try to wrap it smoothly around a ball; it doesn't fit. Neither can a map fit the globe; it must be incorrect either in distances or in directions or in shape—or all of them. On a small area, the difference isn't noticeable; you can map the United States with an error of about 2 per cent. But when it comes to a map of the entire globe—it can't be done!

You can find a discussion of these problems, which are a little too technical to discuss here, in a book of "true confessions" by the United States Coast and Geodetic Survey—"Elements of Map Projection," Special Publication No. 68. But to pass on to the subject of the earth and its relation to radio—

The shortest line on the surface of the earth is *not the shortest line on the map*, except along the equator or along a due north-and-south line. Between two points in different longitudes, on the same side of the equator, it swings up toward the pole. You will recall that, if you remember the maps of Lindbergh's flight across the Atlantic; the shortest route from New York to Paris took him far north of both cities.

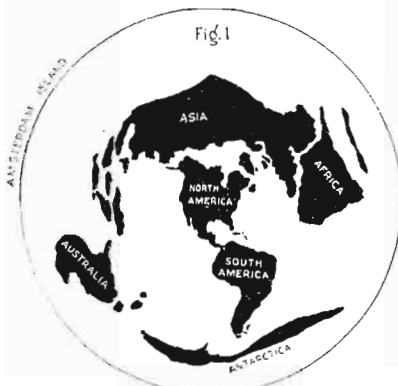

The line of radio reception is also the *shortest line*. You cannot determine it correctly, for any great distance, from a map.

Next of the facts bearing on radio reception is that the earth is *not* standing up neatly on end, with the North Pole at the top and the South Pole at the bottom, as the maps show it. You will notice that a globe is tilted over, so that some point on the Arctic Circle is at the top.

Perhaps you have had illustrated to you, with the aid of a globe, why the seasons change; in December the North Pole and the Arctic regions are pointed away from the sun—always toward the North Star. The Antarctic regions are enjoying summer—which is nothing to brag of down there, at 20 or 30 below zero—and so are Australia and South Africa and the countries of the lower half of South America. On December 22 there is no sunlight in the whole Arctic zone, and "nothing else but" in the Antarctic. The equator, as always, is enjoying sunrise and sunset regularly, at about six o'clock a. and p. m. See Figs. B and C.

On the other hand, on June 21 the entire Arctic is illuminated by the sun at midnight; while the Antarctic is dark. For a great part of the earth's northern portion, there is very little darkness during any portion of the twenty-four hours. And,

Six stations, approximately as shown on the preceding page, may be located at the ends of three diameters of the earth, each perpendicular to the other two. The beams between them may be turned until they all pass through any one point, say X, on the face of the earth.

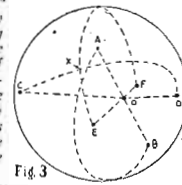

as we all know, radio reception is not as good in daylight as at night. At nine o'clock of a summer evening in the northern hemisphere, the greater portion of the radio audience of the world is not favored by the complete darkness it desires for distant reception. Even when a broadcast station is in the shadows of night, listeners to the west are still in daylight.

THE ADVANTAGE OF LONG NIGHTS

Conversely, in December the larger portion of the entire North Temperate zone

Fig. 1, at the left, indicates the peculiarly distorted condition of a map which represents only the direction and distance of points on the earth from its center. At 12,400 miles from the center, our rim corresponds to one single point on the earth's surface, opposite our starting point. At the right, Fig. 2 shows how short waves sent from a vertical transmitter, no matter how it is turned, are always directed at the same point. The skip effect of the waves is illustrated at both sides.

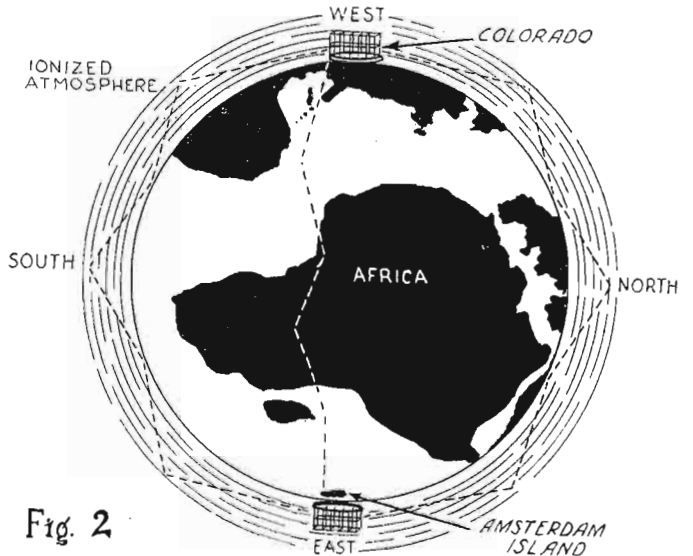

grows dark at an early hour; and stations which are in operation are heard for enormous distances when local interference and weather conditions permit. Then we have listeners' tests that are really successful—unless there is too much competition from old-style sets of the poisonous variety.

At this time listeners who are far to the north are more favored, so far as radio is concerned. They have around them an enormous area of darkness, which is very little relieved during the day. During some hour of the twenty-four there will be practically complete darkness between the Arctic Circle and any broadcast transmitter in the world, or at least, absence of direct sunlight. For this reason, the northmen are able to make long-distance records. Some very good records have been reported from Greenland and Arctic Canada.

The tropical listener, however, has no long nights in winter; no short nights in summer; and a good deal of static to contend with.

But when we consider localities of extreme separation, as between England and Australia, it is impossible to have darkness continue long over the whole distance. Of two points exactly opposite on the globe ("antipodes") one must be in daylight while the other is in darkness or twilight—except for the short time while the sun is setting at one and rising at the other, and consequently in view at both places. More about the "antipodes" later on; they are very interesting subjects, and may be of the greatest importance in the development of radio science.

Now, Jules Verne and many other writers have wrestled with the proposition of altering the earth's seasons, and found that it is impracticable—which is just as well. With more feasibility, certainly, radio engineers are seeking methods of overcoming the difficulties of daylight broadcasting by using greater power, and different wavelengths. While a high-power broadcast station can sometimes be heard by a good receiver in a specially-favored location, halfway round the earth under cover of darkness, it has been found that extremely-short-wave broadcasts can be heard in daylight over enormous distances. Though this development is still in the experimental stage, it is one of the most interesting at the present time in its possibilities.

(Continued on page 1375)

Fig. 2

# List of Broadcast Stations in the United States

Radio Call Letter	BROADCAST STA. Location	Wave (meters)	Power (Watts)	Radio Call Letter	BROADCAST STA. Location	Wave (meters)	Power (Watts)	Radio Call Letter	BROADCAST STA. Location	Wave (meters)	Power (Watts)	Radio Call Letter	BROADCAST STA. Location	Wave (meters)	Power (Watts)
KDKA	East Pittsburgh, Pa.	316	5000	KGES	Central City, Neb.	204	10	KWG	Stockton, Calif.	345	50	WDBO	Orlando, Fla.	288	*500
(Also 62.5, 63.5, 64.5 meters and other short-wave transmissions on varying power)				KGEW	Fort Morgan, Colo.	219	*100	KWJJ	Portland, Ore.	250	50	(WX, variable, 250 watts)			
KDLR	Devils Lake, N. D.	231	15	KGEZ	Kalispell, Montana	242	10	(Also 53.5 meters, 100 watts)				WDEL	Philadelphia, Pa.	297	100
KDYL	Salt Lake City, Utah	234	500	KGFB	Iowa City, Iowa	224	10	KWK	St. Louis, Mo.	284	*1000	WDF	Minneapolis, Minn.	286	500
KDJR	Los Angeles, Calif.	232	250	KGFF	Alva, Oklahoma	205	25	KWKC	Kansas City, Mo.	222	100	WDD	Chattanooga, Tenn.	244	500
(OXAN, 105.9 meters, 250 watts)				KGFG	Oklahoma City, Okla.	216	50	KWKH	Shreveport, La.	305	3500	WDR	New Haven, Conn.	283	500
KELV	Burbank, Calif.	229	500	KGFI	Los Angeles, Calif.	220	15	KWKS	Pullman, Wash.	395	500	WDF	Winstan, R. I.	248	1250
KEX	Portland, Ore.	278	2500	KGFI	Los Angeles, Calif.	213	100	KWTC	Santa Ana, Calif.	273	100	WDF	Chicago, Ill. (daytime)	278	100
KFAB	Phoenix, Ariz.	322	500	KGFM	Hallock, Minn.	321	50	KWV	LeMars, Iowa (day)	*244	1500	WEAF	Fletcher, N. C.	*492	50,000
KFAU	Boise, Idaho	286	*2000	KGFW	Raton, N. M.	222	50	KWVG	Brownsville, Texas	278	500	WEAN	North Plainfield, N. J.	263	250
KFB	Havre, Mont.	275	50	KGFA	Aneta, No. Dak.	300	15	KWVW	Portland, Ore.	335	500	WEAN	Providence, R. I.	275	500
KFCB	San Diego, Calif.	248	100	KGFB	Los Angeles, Calif. (port.)	204	100	KX	Seattle, Wash.	320	100	WEAO	Chicago, Ill. (daytime)	283	500
				KGFC	Ravenna, Neb.	297	10	KXO	Portland, Ore.	290	100	(Also 54.02 meters, 250 watts)			
				KGFD	Pierre, S. D. (day)	251	200	KXRO	Aberdeen, Wash.	224	50	WEAR	Cleveland, Ohio	*4100	1000
KFB1	(alpine) Calif.	201	50	KGFE	Hot Springs, Ark.	506	*1000	KYA	San Francisco, Calif.	361	1000	WEBC	Superior, Wis.	342	*250
KFB2	Sacramento, Calif.	275	100	KGFF	Sioux Falls, S. D.	219	50	KYB	Chicago, Ill.	320	*2300	WEBC	Cambridge, Ohio	248	10
KFB3	Everett, Wash.	224	50	KGFG	Cedar Grove, La.	213	50	KZM	Chicago, Ill.	281	100	WECH	Chicago, Ill.	306	*500
KFB4	Laramie, Wyo.	484	500	KGHH	Ingewood, Calif. (port.)	204	100	NAA	Arlington, Virginia	*434	1000	WECH	New York, N. Y.	*256	500
KFB5	Phoenix, Ariz.	319	500	KCHA	(6XAL, 69.04 meters, 50 watts)	500		WAAD	Cincinnati, O.	231	25	WEBO	Harrisburg, Ill.	224	15
KFCR	Santa Barbara, Calif.	311	100	KGHB	Honolulu, Hawaii	210	500	WAAF	Chicago, Ill.	389	500	WEBR	Buffalo, N. Y.	242	200
KFDM	Beaumont, Texas	484	500	KGHC	Slayton, Minn.	210	15	WAAM	Oakland, Calif.	231	100	WECH	Chicago, Ill.	255	500
KFDX	Shreveport, La.	236	250	KGHD	Missoula, Mont. (day)	232	5	WAAT	Jersey City, N. J.	246	300	WECH	Chicago, Ill.	255	500
KFD1	Brooklyn, N. Y.	319	500	KH	Pueblo, Colo.	210	250	WAAW	Omaha, Neb. (daytime)	411	500	WEDC	Chicago, Ill.	306	*500
KFD2	Minneapolis, Minn.	216	10	KH2	Hardin, S. D.	245	50	WABC	Richmond Hill, N. Y.	309	*2500	WEEH	Buffalo, N. Y.	219	30
KFD3	Portland, Ore. (day)	214	50	KH3	Oakland, Calif.	*384	5000	(Also 64.0 meters, 500 watts)				WEEH	Boston, Mass.	509	500
KFD4	Portland, Ore. (night)	214	50	(Short-wave transmitter, 10 to 40 watts)			WABF	Kingston, Pa.	205	250	(148 short-wave transmitter)				
KFEF	Denver, Colo.	227	250	KGRC	San Antonio, Texas	220	250	WABI	Baker, Mo. (Sundays)	389	100	WEMC	Evansville, Ind.	348	100
KFEQ	St. Joseph, Mo.	231	*1000	KGRS	Amarr, Tex.	214	*250	WABO	See WHEC			WENS	Berlin Spgs, Mich.	484	1000
KFKL	Kelso, Ind.	312	10	KGTT	San Francisco, Calif.	220	50	WABW	Richmond, Ohio	248	50	WENR	Chicago, Ill.	288	500
KFKQ	Boone, Iowa	210	10	KGU	Honolulu, Hawaii	270	50	WABX	Philadelphia, Pa.	248	50	WEP	Greenchester, Mass.	297	100
KFH	Wichita, Kan.	246	500	KGV	Puerto Rico	210	500	WABY	New Orleans, La.	238	50	WEP	St. Louis, Mo.	246	500
KFHA	Gunnison, Colo.	250	50	KGW	Portland, Oregon	492	1000	WABZ	New Orleans, La.	238	50	WF	Dallas, Texas	545	500
KFHL	Oakland, Calif.	468	5000	KHX	Lacey, Wash.	246	50	WADC	Akron, Ohio	238	1000	WFAM	St. Cloud, Minn.	252	10
KFIM	Portland, Ore.	229	50	KHY	Los Angeles, Calif.	490	1000	WADF	Detroit, Mich.	231	100	WFAN	Philadelphia, Pa.	224	500
KFIO	Spokane, Wash.	246	100	(Also 104.1 meters, 30 watts)			WAFD	Royal Oak, Mich.	257	50	WFAN	Newark, N. J.	263	500	
KFIU	Jamez, Alaska	225	10	KHMC	Harlingen, Tex.	236	100	WAIT	Taunton, Mass.	514	10	WFBE	Cincinnati, Ohio	236	250
KFIW	Fond du Lac, Wis.	*268	100	KHK	Spokane, Wash.	370	1000	WAIU	Columbus, Ohio	283	5000	WFBG	Altoona, Pa.	268	100
KFJB	Marshalltown, Iowa	248	*100	KKK	Red Oak, Iowa (day)	322	100	WAIZ	Appleton, Wis.	227	100	WFBJ	Collegeville, Minn.	273	100
KFJ	Oklahoma City, Okla.	273	5000				WALK	Willow Grove, Pa.	201	50	WFBM	Syracuse, N. Y.	258	750	
KFJJ	Astoria, Ore.	250	15	KJBS	San Francisco, Calif.	246	100					WFBM	Indianapolis, Ind.	347	1000
KFJM	Grand Forks, N. D.	353	100	KJR	Seattle, Wash.	339	2500					WFBM	Baltimore, Md.	244	*250
KFJN	Portland, Ore.	240	500	(Also 105.3 meters, 5 to 250 watts)								WFBZ	Galesburg, Ill.	243	50
KFJY	Fort Dodge, Iowa	232	100	KKP	Seattle, Wash.	273	15					WFCI	Pawtucket, R. I.	242	100
KFKZ	Fort Worth, Texas	250	50	KLCN	Blytheville, Ark. (day)	236	50					WF	Philadelphia, Pa.	273	100
KFKA	Greeley, Colo.	250	500	KLCD	Independence, Mo.	150	1500					WFI	Hopkinton, Mass.	261	*750
KFKB	Midvale, Kansas	*242	1500	KLE	Portland, Ore.	200	10					WFI	Akron, Ohio	227	500
KFKU	Lawrence, Kansas	254	500	KLTS	Oakland, Calif.	246	250					WFCM	Chicago, Ill.	234	500
KFKX	Chicago, Ill.	526	2500	KLX	Oakland, Calif.	508	500					WFKD	Philadelphia, Pa.	234	500
KFKZ	Kirkville, Missouri	225	15	KMA	Shenandoah, Iowa	393	1000					WFLA	Clearwater, Fla.	517	750
KFLV	Rockford, Ill.	308	100	KMB	See KLEDS							WGL	Frederic, Pa.	252	15
KFLX	Galveston, Texas	209	100	KMED	Medford, Oregon	295	500					WGBB	Laurens, N. Y.	246	150
KFMR	Sioux City, Iowa	232	100	KMCL	Ingewood, Calif.	224	250					WGBB	Memphis, Tenn.	229	150
KFMX	Northfield, Minn.	236	500	KMMJ	Clay Center, Neb.	286	250					WGBF	Evansville, Ind.	348	2500
KFN	Shenandoah, Iowa (day)	461	2000	KMMO	Tacoma, Wash.	254	500					WGBI	Seranton, Pa.	231	250
KFN1	Seattle, Wash.	447	1000	KMX	1st. Louis, Mo.	300	5000					WGBS	New York, N. Y.	349	500
KFN2	Long Beach, Calif.	242	1000	KMTR	Los Angeles, Calif.	517	500					WGBM	Gulfport, Miss.	222	15
KFOR	Lincoln, Neb.	217	100	(Also 108.2 meters, 15 watts)								WGBS	Richmond, Va.	347	100
KFOX	Omaha, Neb.	258	100	KMX	(Also 108.2 meters, 250 watts)							WGBS	Chicago, Ill.	288	250
KFPL	Dublin, Texas	275	15	KNR	Santa Monica, Calif.	375	500					WGBS	Chicago, Ill.	288	250
KFPR	Los Angeles, Calif.	232	250	KNX	Los Angeles, Calif.	337	500					WGBS	Chicago, Ill.	288	250
KFPY	Carterville, Mo.	263	50	(Also 107.1 meters, 100 watts)								WGBS	Chicago, Ill.	288	250
KFY	Spokane, Wash.	249	250	KOA	Denver, Colo.	*326	5000					WGBS	Chicago, Ill.	288	250
(7XAB, 105.3 meters, 100 watts)				KOAC	Corvallis, Oregon (day)	270	7000					WGBS	Chicago, Ill.	288	250
KFQA	St. Louis, Mo.	334	500	KOB	St. Louis, Mo.	337	500					WGBS	Chicago, Ill.	288	250
KFQB	Port Worth, Texas	333	1000	KOB	St. Louis, Mo.	337	500					WGBS	Chicago, Ill.	288	250
KFQC	Anchorage, Alaska	345	100	KOB	St. Louis, Mo.	337	500					WGBS	Chicago, Ill.	288	250
KFQD	Holy City, Calif.	220	100	KOB	St. Louis, Mo.	337	500					WGBS	Chicago, Ill.	288	250
KFQE	31.43, 61.0 meters, 50 watts			KOB	St. Louis, Mo.	337	500					WGBS	Chicago, Ill.	288	250
KFQF	Seattle, Wash.	217	100	KOB	St. Louis, Mo.	337	500					WGBS	Chicago, Ill.	288	250
KFQZ	Hollywood, Calif.	232	250	KOB	St. Louis, Mo.	337	500					WGBS	Chicago, Ill.	288	250
(Also 108.2 meters, 50 watts)				KOB	St. Louis, Mo.	337	500					WGBS	Chicago, Ill.	288	250
KFR	San Francisco, Calif.	435	1000	KOB	St. Louis, Mo.	337	500					WGBS	Chicago, Ill.	288	250
KFR1	Columbia, Missouri	250	500	KOB	St. Louis, Mo.	337	500					WGBS	Chicago, Ill.	288	250
KFR2	San Diego, Calif.	441	500	KOB	St. Louis, Mo.	337	500					WGBS	Chicago, Ill.	288	250
KFR3	Los Angeles, Calif.	252	500	KOB	St. Louis, Mo.	337	500					WGBS	Chicago, Ill.	288	250
(Has short-wave transmitter)				KOB	St. Louis, Mo.	337	500					WGBS	Chicago, Ill.	288	250
KFUL	California, Texas	484	500	KOB	St. Louis, Mo.	337	500					WGBS	Chicago, Ill.	288	250
KFUM	Colorado Spgs, Colo.	484	1000	KOB	St. Louis, Mo.	337	500					WGBS	Chicago, Ill.	288	250
KFUP	Clifton, Mo.	545	*1000	KOB	St. Louis, Mo.	337	500					WGBS	Chicago, Ill.	288	250
KFUF	Denver, Colo.	227	100	KOB	St. Louis, Mo.	337	500					WGBS	Chicago, Ill.	288	250
KFUG	Ogden, Utah	285	50	KOB	St. Louis, Mo.	337	500					WGBS	Chicago, Ill.	288	250
KFUS	California, Missouri	208	50	KOB	St. Louis, Mo.	337	500					WGBS	Chicago, Ill.	288	250
KFUT	Salt Lake City, Utah	250	50	KOB	St. Louis, Mo.	337	500					WGBS	Chicago, Ill.	288	250
KFVD	Yonkers, Calif.	216	250	KOB	St. Louis, Mo.	337	500					WGBS	Chicago, Ill.	288	250
(Also 105 meters, 50 watts)				KOB	St. Louis, Mo.	337	500					WGBS	Chicago, Ill.	288	250
KFVG	Independence, Kan.	328	50	KOB	St. Louis, Mo.	337	500					WGBS	Chicago, Ill.	288	250
KFVI	Houston, Texas	228	50	KOB	St. Louis, Mo.	337	500					WGBS	Chicago, Ill.	288	250
KFVS	Cape Girardeau, Mo.	*224	500	KOB	St. Louis, Mo.	337	500					WGBS	Chicago, Ill.	288	250
KFVB	Los Angeles, Calif.	*353	1000	KOB	St. Louis, Mo.	337	500					WGBS	Chicago, Ill.	288	250
(Also 105 and 40 meters, 500 watts)				KOB	St. Louis, Mo.	337	500					WGBS	Chicago, Ill.	288	250
KFWC	Omaha, Neb.	333	1000	KOB	St. Louis, Mo.	337	500					WGBS	Chicago, Ill.	288	250
KFW1	St. Louis, Mo.	214	250	KOB	St. Louis, Mo.	337	500					WGBS	Chicago, Ill.	288	250
KFW2	San Francisco, Cal.	268	500	KOB	St. Louis, Mo.	337	500					WGBS	Chicago, Ill.	288	250
KFW3	Oakland, Calif.	236	300	KOB	St. Louis, Mo.	337	500					WGBS	Chicago, Ill.	288	250
KFW4	Avon, Calif.	250	250	KOB	St. Louis, Mo.	337	500					WGBS	Chicago, Ill.	288	250
(Also 33.7 meters, 100 watts)				KOB	St. Louis, Mo.	337	500					WGBS	Chicago, Ill.	288	250
KFXD	Jerome, Idaho	204	*15	KOB	St. Louis, Mo.	337	500					WGBS	Chicago, Ill.	288	250
KFXE	Denver, Colo.	283	250	KOB	St. Louis, Mo.	337	500					WGBS	Chicago, Ill.	288	250
KFXF	Edgewater, Colo. (near)	210	50	KOB	St. Louis, Mo.	337	500					WGBS	Chicago, Ill.		



# "Inside Stuff" for Radio News Readers

A Few Special and Some Regular Notices  
to Help You Get More Out of this Magazine



IT IS NECESSARY TO LET YOU IN ON A FEW THINGS about the editorial work of this magazine, in order that you may better take advantage of the things it offers you—so this page is established for that purpose.

FIRST OF ALL, WE WISH TO ACKNOWLEDGE THE PROMPT APPRECIATION you have shown for our Free Blueprint offer. This is written just one month after the first publication of this new policy of RADIO NEWS; and it will interest you—as it has surprised us—to learn that our readers have called and written in for TWO THOUSAND FIVE HUNDRED AND EIGHTY sets of blueprints (up to April 11th) of the Special Short-Wave receiver featured in our April issue; on one day as many as two hundred and eleven requests were received and supplied, and they are still coming in at the rate of more than fifty a day.

THE FULL-SIZE BLUEPRINTS OFFERED IN THIS ISSUE ARE FOR A NEW PRIZE WINNER—THE NEURO-HETERODYNE, the circuit of which was described in the May issue, and for a Two-Tube Audio Amplifier, suitable for use with the "Extension" receiver described in "The Radio Beginner" pages of last month's issue, but capable of being attached to the detector output of any simple set. (You will find the articles on pages 1336 and 1332, respectively, of this magazine, with the diagrams on a smaller scale.)

THE BLUEPRINTS ARE FREE TO ANYONE WHO WILL CALL AT THIS OFFICE; it is open from 9:00 a. m. to 5:30 p. m., except on Saturdays, when it closes at 1:00 p. m. If you write in and ask that the blueprints be mailed, kindly do not forget to enclose TEN CENTS in COIN OR U. S. STAMPS FOR EACH SET TO COVER MAILING COSTS; the blueprints are quite bulky, especially for the larger sets, such as the superheterodyne. With each set is included a sheet showing the parts originally used and the names of their manufacturers; this is not published in RADIO NEWS, owing to our new policy—which, judging from the letters so many of you have written, meets with your hearty approval.

BLUEPRINTS ISSUED BEFORE APRIL, 1928, ARE NOT GIVEN AWAY. The reason is that these were produced one at a time by an expensive process, and are worth the price charged. Those made for free distribution, though equally useful, are printed on a press in large quantities, as the only way of reducing the expense to a figure that permits us to give them away. RADIO NEWS cannot furnish at any price blueprints of manufactured sets, or others which have not been published in these pages since October, 1926.

WE ARE OFTEN ASKED FOR CONSTRUCTIONAL DATA ON EXPERIMENTAL APPARATUS which is not yet on the market, such as the most successful Television receivers. When we stated in a published article that such information is not available, we mean it; and our "I Want to Know" department urgently requests experimenters to take the statement at its face value. When the necessary details for building interesting radio novelties have been worked out in the RADIO NEWS Laboratories, they are published for all; until then, the experimenter who wants to go ahead on the idea must do his own cutting and trying.

THE MAGAZINE CLOSES ITS FORMS ONE MONTH BEFORE PUBLICATION. When a reader asks that "this be published in your next issue," he is asking an impossibility. So also it is impossible to keep a broadcast list, for instance, corrected up to date when it is subject to daily change. Readers who send in letters, etc., for publication, are therefore urged to be patient. This delay is caused by the fact that it is necessary to set and electrotype the forms, print and bind two hundred thousand magazines and ship them to all parts of the world.

AN ARTICLE DEVOTED TO LEARNING THE RADIO CODE will appear in an early issue of RADIO NEWS. Thousands of our readers who have no intention—at least at present—of becoming transmitting amateurs, will derive a great deal of pleasure from the possession of the ability to know what is going on in the ether—only one little page of which, so to speak (the broadcast band) has hitherto been open to them.

HAVE YOU YET SENT IN YOUR BALLOT FOR EDITORIAL POLICES? This was printed in the May issue, and we expect to receive many thousands of votes during the next few weeks. The results will be compiled and announced, and reflected in the greater or less amount of space allowed to general or technical articles, as required by the votes of our readers.

THE RECEIVER WHICH IS FEATURED IN THIS ISSUE IS THE NEUROHETERODYNE, free blueprints (Set No. 56) of which are offered to our readers who desire to build a superheterodyne whose intermediate transformers they can readily construct. It should appeal to every enterprising set builder. The article begins on page 1336.

THIS RECEIVER WON THE \$100.00 MONTHLY PRIZE FOR ITS DESIGNER, MR. HERBERT J. REICH, of Cornell University. Several entries have been received for the prize for July and future months, but the date of final entry has not arrived; so that the announcement cannot yet be made of the winner for July. Every constructor anywhere—except one who is working on developments on behalf of a manufacturer—is entitled to compete, but attention must be paid to the rules, which were printed in the April issue, and are again summarized here.

ONLY A RECEIVER, AMPLIFIER, OR POWER UNIT, ETC., WHICH HAS BEEN ACTUALLY BUILT can be entered; the prize is for the construction as well as the idea. Many bare theories have been presented, which cannot be considered for this purpose. An entry must be accompanied by photographs of the apparatus, a statement of its construction and performance *type-written or written in ink*, and a complete and accurate schematic diagram on good white paper. The competitor's name must be written on every sheet and all fastened together and mailed *flat*. Do not send any apparatus until you are so instructed from this office.

IF THE DEVICE SUBMITTED CONTAINS A NEW AND PATENTABLE IDEA, RADIO NEWS will pay for the entire cost of taking out a patent in the name of the inventor, to whom it will belong.

THE SECOND FREE BLUEPRINT ARTICLE (it is printed first—on page 1332) is a simple two-tube audio amplifier (Set No. 55), designed for use with the "Extension Two-Tube Receiver," printed last month, also in "The Radio Beginner" pages. The frequent requests received by us show that there is a continual demand for simple circuits, from the late-comers in radio who want to get a start. We shall next publish in the July issue, a simple crystal set suitable for reception of local stations.

MANY WHO WOULD LIKE TO TRY SHORT WAVE WORK HESITATE at the idea of the cost of a new set solely for this purpose, when they do not know what can be expected of it. In the July issue of RADIO NEWS will appear a Free Blueprint article describing the construction of a "junkbox" short-wave set which has been tested in the Laboratories and found very efficient. Most experimenting constructors have enough parts on hand to build it in a few hours without a cent of added investment.

WE REGRET, AS WILL OUR READERS, THE ABSENCE OF DAVID GRIMES' ARTICLE, which was promised for this issue. Mr. Grimes became seriously ill shortly after the writing of the announcement (in the May issue) of the series of articles which he is to contribute to this magazine; and did not recover in time to prepare the second of the series.

THE "I WANT TO KNOW" department of this magazine handles inquiries as to apparatus approved by the RADIO NEWS Laboratories, and other service questions for our readers. The new caption above this department (on page 1355) announces a widening of the service which it will render free; but we must ask our readers to comply with the terms laid down. The burden of mail upon this department is enormous, and letters which are not written clearly and provided with legibly-addressed return envelopes increase the work and cause delays in replying.



# The Radio Gun --- The Silent Weapon of the Future

How Concentrated Radio Impulses Might Be  
Made to Act as "Death Rays"

By Joseph Riley

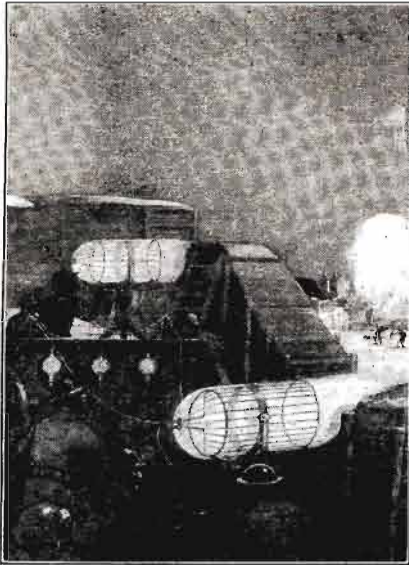

The radio gun lays down a silent, invisible barrage which nothing living may cross.

**A**BOUT six years ago the world was startled to read of the invention, by an Englishman, of a so-called "death ray," to which the press attributed lethal powers far wider and more terrible than those possessed by any known weapon of destruction. The news of the advent of this allegedly deadly ray caused a great deal of excitement, in the American daily newspapers, at least; but this quickly petered out when inquiring reporters learned that no demonstrations of the ray's effectiveness could be given and that the inventor himself was about the only person who had ever been convinced of its effectiveness at all.

Although this particular "death ray" obviously was not fully developed, and did not deserve the widespread attention it was accorded, faith in the practicability of ideas of this general nature has been strengthened by recent experiments performed with vacuum-tube oscillators working on extremely high frequencies. Some of the extraordinary physiological effects produced by a 15-kilowatt tube operating on 50,000 kilocycles (6 meters) were described in last month's *Radio News*, in an article entitled "High Frequency Magic in the Laboratory," to which the reader is referred for details. Now along comes Dr. Phillips Thomas, a Westinghouse research engineer, with the suggestion that radio waves of even shorter length, suitably concentrated by means of reflectors, might, in times of war, be turned

into "death rays" which would actually possess some of the destructive powers of the mysterious death rays of fiction and of newspaper interviews.

## A RADIO SEARCHLIGHT

In a recent paper dealing with the subject, "Power by Radio," Dr. Thomas, discussing the problem of reflecting ultra-short radio waves, points out an analogy to light rays.

"Here we have a simple automobile spotlight," he writes. "If I shoot it at a wall or screen, the bright spot caused is only the size of the opening in the reflector. If the reflector were not there, the light would be sent out equally (nearly) in all directions, just as is the wave from a broadcast antenna. Why, then, cannot we build a reflector and concentrate the beams from such a source, just as we do the light beams? We can.

"Senatore Marconi has developed such systems, for message transmission, to a very efficient point. In fact, Hertz, the discoverer of these waves whose existence and qualities Clerk Maxwell had predicted from theory, showed that everything could be done to them which could be done to light waves.

"But notice the size of the reflector on the spotlight and consider that the light waves have for wavelength a very small fraction of an inch. In order to reflect or focus waves, the mirror must have an opening equal to, at least, the length of one wave. Quite a mirror, then, would be required to reflect a 300-meter wave. Even a two-meter (six-foot) mirror, would be too large for comfort, and would reflect a beam too far across for power purposes.

## AN INVISIBLE CONDUCTOR

"But suppose, now, that we have a wave of ten centimeters (four inches) in wavelength; we could then reflect it, exactly as we do the light beams. And suppose, again,

that we had a means of concentrating power in a respectable amount, in that beam. The actual power sent out, as light, by the spotlight lamp, is very much less than one watt, and yet it is quite a powerful thing when concentrated by the mirror. What effects then, should we expect, were we able to send out a power of say a few thousand watts—kilowatts—in such a beam? It is quite within reason to expect that the air in its path would become "ionized"—would change from a very good insulator to quite a fair conductor of electricity. We should then have the equivalent of a small copper wire, except that it would have no weight. No poles would be required on which to hang it. It could be aimed at any desired point, without allowing for range. Two such beams, along parallel paths, could have their reflectors connected to the high-voltage terminals of a transformer, and a current would flow between the distant ends of the beam. If the two targets were metal plates connected to a transformer arranged to step down the voltage, power could be derived at the receiving end, without any radio apparatus being required.

"And the power to be sent would not have any necessary relation to the size of the radio apparatus at the sending end; so that, once we had the ionized paths, the power sent along them could be many times that required to ionize them. This apparatus could be used to great advantage in cases where power is required in locations where the difficulty or expense of stringing wires would prohibit its delivery in the usual way.

## A NEW MILITARY ARM

"Such apparatus, besides its peace-time uses, would be of tremendous value in war time; because it would be fatal to life to come into the path of rays energized with high voltage, just as it is fatal to pick up a high-tension wire from the ground. In other words, it would constitute the 'death ray,' which has received so much attention from inventors. An invading army would indeed be in hard luck, were its opponents equipped with such apparatus, the stroke of which would be noiseless and—at least in daytime—invisible.

"All of the above is quite feasible on one supposition, namely, that we have the ten-centimeter waves, with the kilowatts of radio power behind it. This supposition is at present impossible of realization, because of the limitations of vacuum tubes of the standard type. It is not, however, nearly as long a step from the present tubes to tubes of the required type, as it was to the present device from no tube at all. In fact, a type of tube has been worked out on paper, and is soon to be tried experimentally, which bids fair to give us exactly what is required. And there are doubtless other designs which will do the same thing.

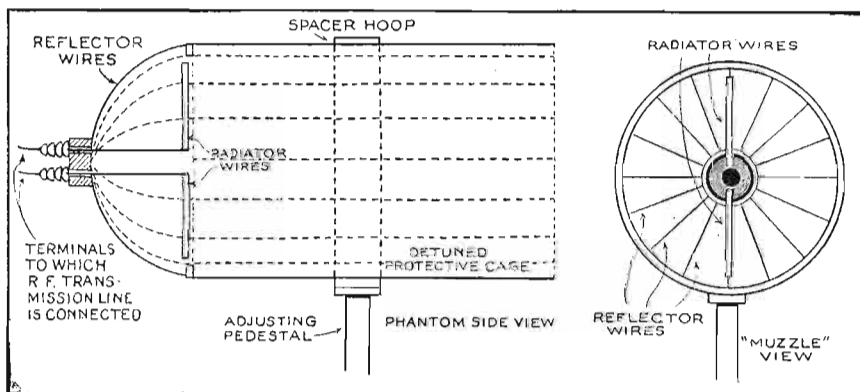

This drawing shows what the "Radio Gun" of the future may be like. The device would be about 10 or 12 inches in diameter and 2 or 3 feet long.

and which will very probably be worked out before any very great length of time."

**A SIMPLE PROJECTOR**

From Dr. Thomas' description of a theoretical radio power system, it is not difficult to envision the radio gun as the deadliest military weapon of the future. With laboratory engineers already using 15-kilowatts of power on six meters, raising the temperature of the human body, cooking apples, and killing rats—and with radio amateurs successfully transmitting on three-quarters of a meter (75 centimeters)—the step to a ten-centimeter wave with fifteen or twenty kilowatts behind it is not such a very long one. The shortness of the wave will greatly simplify the reflector problem; all that probably will be necessary is a wire cylinder closely resembling a bird cage. The radiator wires, generating the actual radio waves, could be placed at the focal point of a "paraboloidal" reflector (somewhat in shape like a searchlight reflector), which would form the closed end of the cage. The imaginary details of such a radio gun, capable of producing a real "death ray," are shown in the drawing at the foot of the opposite page, while the other illustrations depict its possible uses in future warfare.

The death-ray projector itself would be extremely light, but the generating equipment would of necessity be bulky and heavy. It, probably, would have to be built into two or three field trucks; or possibly the power necessary might be transmitted from a powerhouse behind the lines along a pair of ionized paths, such as Dr. Thomas describes. If this could be done, the only front-line apparatus needed would be a radio-frequency oscillator, connected by R.F. transmission lines to the ray projectors themselves.

The ray projected by such a radio gun would not only be fatal to any human being it encountered, but destructive also to any machinery employing electrical devices. For instance, a ray directed at a lumbering tank would probably burn out the ignition sys-

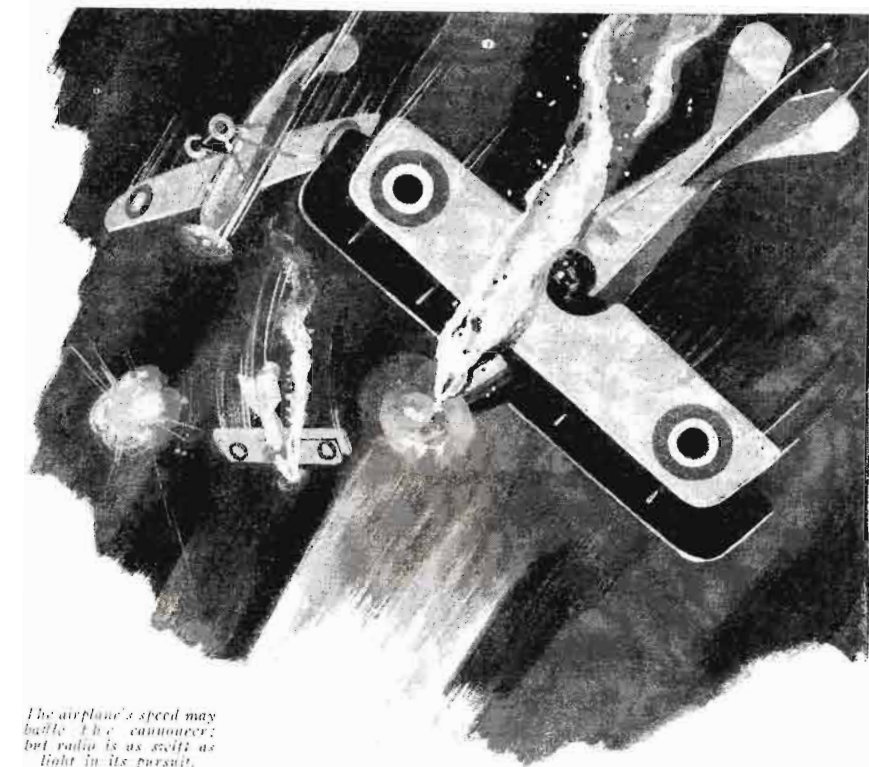

*The airplane's speed may battle the cannonery; but radio is as swift as light in its pursuit.*

tem instantly, leaving the vehicle helpless. The ray might also induce in the metal body itself enough current to make life distinctly unpleasant for the occupants.

**AN ANSWER TO THE PLANE**

The radio gun would make a perfect weapon against aircraft; because it could sweep the sky like a veritable searchlight until it lit upon an enemy plane, the presence and position of which could be determined quite accurately by "finders" such as are in existence even to-day.

Obviously, this deadly weapon would

possess undesirable features which might limit its military usefulness. For example, its rays travel in a perfectly-straight line; so that it would be fully exposed to enemy fire while being used. This shortcoming might be partially overcome by building the projector upon a disappearing mechanism, not unlike that employed on coast-defense guns; so that it could be swung into "firing" position for a few seconds and then quickly pulled down. If it were destroyed, it could be replaced in a few minutes by another projector, at a cost considerably lower than that of a single medium-sized artillery shell.

During daylight the invisibility of the projected rays would be one of the weapon's great features; but, during darkness it might betray the position of the apparatus to enemy fliers. In such an event, the duel between a freely-swinging death beam and a few blindly-dropped bombs would determine the victor.

It is difficult to predict how dangerous the radio gun would be to the men handling it in actual warfare, as the physiological effects of high-frequency energy on the human body are not yet fully understood. The generated high-frequency current itself would probably be harmless until it was actually converted into waves by the radiator wires inside the "gun"; but, if the waves showed a tendency to leak out through the sides of the reflector (as the waves of our present-day beam transmitters have a distressing habit of doing), the men manipulating the weapon might suffer some discomfort. This possible trouble could probably be eliminated by the use of adequate reflectors, protected more completely than the one shown in the drawing on the opposite page.

It might be necessary, also, to mask the sides of the reflector with heat-reflecting material, as done today with large searchlights, to confine shorter-wave or heat rays simultaneously generated by the radiator.

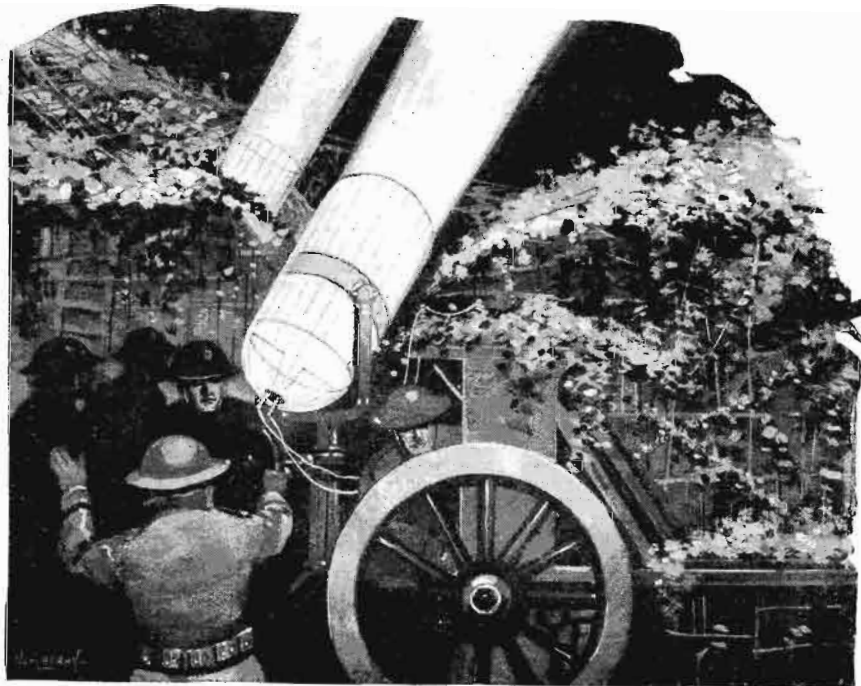

*The radio gun sweeps the sky, which has no lurking-places like the earth and sea.*

# The Port of Missing Airplanes



In Which the Most Famous of Conceivable Film Stars Summons the Resources of Science to Unravel a Sinister Mystery and Foil a Fiendish Plotter!



By C. Sterling Gleason

IN the radio operating room at Bandy Field, Alfred Neverre, portly president of the Neverlate Aerial Express Company, sat tensely beside the two crack operators who were keeping watch over the Hawaiian flight route. Far out above the broad bosom of the deep Pacific, a huge NAEC transport was flying into the night; and out across that vast expanse of sea reached the long arm of radio, guiding the plane with its precious cargo of passengers safely over the three thousand perilous miles that lay between Los Angeles and Honolulu.

The haggard face of Alfred Neverre showed sure signs of severe strain and stress. Huddled in his chair sat the portly president, a pair of headphones tightly clutched to his ears, and his whole mind taxed to the utmost by a terrible suspense; for at any moment might come from those sensitive headsets a sound which would mean sure disaster, not only to his personal fortune, but to his company, and to the whole aerial transportation industry as well. Upon the meaning of those shrill pipings hung the fate of the NAEC.

Suddenly in the operators' headsets the even, musical note of the transport's transmitter soared wildly. Far out at sea, the great plane was slipping sideways—dipping—swinging into a sickening spin—

The shrill note screamed again, higher and higher—

"Going into tail-spin. . . . SOS, SOS, SOS. . . ."

Then it died abruptly. President Neverre collapsed in his chair and buried his face in his hands. "They are down!" he moaned. "Ruined! The NAEC is ruined!"

Whitefaced but determined, the operators frantically clinked their keys. In a moment, two steamers had changed their courses and were steaming at full speed toward the fallen plane, while half a dozen others stood by, ready to join the search at an instant's notice.

President Neverre sat crushed by this appalling news. He was confident that the passengers and pilots of the transport would be rescued; but he also knew that the NAEC, already placed in a precarious position by four such disasters, was now precipitated into a publicity that would mean its ruin so far as commercial transportation was concerned. His staff of aeronautical experts could give no reason for these terrible failures. One, perhaps two, such accidents might reasonably be expected; but when the news came that a third and then a fourth had followed the fate of the others, the shrewder of the experts had begun to suspect that something was wrong. And although insurance might purchase new planes, and protect the company against lawsuits, such disasters were death-blows to the greatest asset of any commercial air company—the confidence of the public.

Then an inspiration seized Alfred Neverre.

world's greatest motion-picture producer and cinema hero, answered the phone in his palatial Hollywood bungalow.

"Mr. Dare," came the voice of Alfred Neverre over the wire, "the newspapers have been full of facts, fancy, fiction, and falsehood regarding the failure of our new Hawaiian passenger service. Although the gravity of the situation has not been exaggerated, we have not yet called a stockholders' meeting; feeling that this would not again happen, or that somehow our experts would solve the mystery. But now the worst has happened. The ship which left Los Angeles at 9:00 o'clock this morning has just crashed. You will see readily enough what this means. We cannot keep the news from the public. There is only one thing that can save us; the news that some great man, whose word is as good as his bond, or better, and who has at his command all the resources of a tremendous organization employing the very greatest of engineering talent, has pledged himself to the solution of this mystery. If you, Mr. Dare, would let the word go out to the papers that you are backing us and lending us the aid of your famous engineering staff, the public's confidence in the NAEC would be preserved. Mr. Dare, may we count on you?"

"Mr. Neverre," spoke Harold Dare, "since you put it in such terms, I will. As one who is personally interested in anything which may be of benefit to the public at large, as one who has at heart only the

1324

Radio News for June, 1928



## You Can't Buy Location

Editor, RADIO NEWS:

After patiently waiting for the March issue, I started to read it; and when I got to page 980 ("Encircling the World with a Two-Tube Set") I read the article three times over, until my head began to swim. Please tell me, how do they get that way?

I have a 50-foot tower, and three smaller ones to keep the aerial from swinging; an aerial 156 feet long with a straight lead-in to the set No. 12 (enameled wire); a ground on a pipe 15 feet into watery clay and one on a lead pipe in wet clay. Everything O.K., "lossless," insulated, etc., etc. I have tried about every set known; supers and others (price no object) and when I get KFI it must be under excellent conditions. I have about \$1,500 invested in the best radio parts, in fact, anything I want. I

than Old Mr. Static. Well, all this is O.K., and tends to improve radio reception in general. But your magazine and all the rest of them, including the home-set builders who contribute these letters, and the parts manufacturers, have overlooked one of the main troubles.

To my mind and way of thinking, the greatest menace and most disgusting part of radio reception is no other than this: when you tune in, sit back in your easy chair—and, all at once, some Antonio Rubeeoles starts to force about 45 minutes of "Maladua qua qua Spagettio!" I ask you, do you know what he is trying to say? Or sing? I think they call it "Grand Opera."

At any rate, I was born right here in the U. S. A. and, like a million or more other

4:14 a. m.: Two Songs (man) with piano. Interference prevented further reception.

Sunday, Feb. 5. Wavelength 30.9 meters: Time 3:45 a. m. to 4 a. m. Dance music R4. Mushy, probably due to over-modulation.

(All times stated are South African Time, 7 hours ahead of E. S. T.)

I have very often received your signals, but would not report until I had definitely received your call sign.

I also enclose a "Broadcastatic". The other evening, Gordon Bird, the announcer at the Cape Town Broadcasting Station, had just wished an old lady listener very many happy returns of the day, it being her 82nd birthday. He then announced "we are now going over to the Alhambra Picture Theatre whose orchestra will entertain you." Over went the switch and what do you think we heard? The Dead March in Saul!

backing you. I myself will see that the matter is given full publicity through my broadcasting station, WROT. And since the matter is so urgent, I feel that a test flight must be made as soon as our engineers can confer and prepare their instruments. I shall order a conference at once."

Throughout the night, Bandy Field was the scene of intense activity. Lights burned everywhere. In the great hangars, aviation experts and mechanics were installing a special equipment and subjecting every inch of the transport, down to the tiniest screw, the most minute gadget, to a searching scrutiny. And in the office of the company, the combined engineering staffs of the NAEC and the Dare studios met in conference.

Harold Dare's famous chief engineer, the great Scott, addressed the group: "Fellow engineers, there is only one way that we can quickly and surely determine the cause of the recent disasters to NAEC transports. A test flight must be made, under strictest scientific supervision, and on the group-research principle, which is the secret of our past success. One group must supervise the mechanical inspection, which will make certain that every part of the ship is in perfect working order. Another group must have charge of the radio installation, and see that the radio beacon functions properly. Still another group must examine the pilot and operator, to make sure that they are in absolutely perfect condition, both physically and mentally. And here the question arises: who is to be the pilot? For this test, we must have a man who not only has had much flying experience, but who is in the pink of physical perfection; a man who is shrewd and quick and keen of judgment; a man of the greatest courage and daring, and yet of remarkable coolness and caution.

**AUTHOR'S NOTE:**

*I really believe that there is a good deal in this air story; it seems to me not only plausible, but perhaps possible. Dr. A. E. Merrill, Professor of Aeronautics at the California Institute of Technology, has shown me a letter from Clarence Chamberlin describing an experience of the latter, in which he went into three consecutive tailspins before he could persuade himself to trust his instruments—the illusion of contrary motion was so strong. In the third tailspin he was only about twenty feet above the water.*

*The close connection between the senses of equilibrium and hearing, upon which this story is based, manifests itself, for example, in one's inevitable start at an unexpected loud noise, as well as the probable identity of the organs of hearing and equilibration in certain lower species.*

*A physicist friend and a doctor both saw possibilities in the idea. At any rate, the study of this subject has interested me greatly, as I think there is no more interesting field than that unexplored boundary between physics and psychology.*

C. STERLING GLEASON.

Only to such a man can we entrust the controls. Where will such a man be found?"

A moment of silence, and then Harold Dare rose to his feet.

"Scott," he said, "your eloquence persuades me. I will pilot the ship."

At this heroic offer there was furious applause. Impulsively Alfred Neverre seized Dare's hand and wrung it warmly.

"Mr. Dare," he said, simply, "you have saved the NAEC!"

\* \* \* \* \*

So, through the long hours of the night, Harold Dare sat in the revolving chair in the examining room at Bandy Field, while eminent psychologists and medical men applied test after test designed to determine, down to the last neurone, the ultimate capsule, the precise physical and mental condition of the great film hero. And when the examination was complete, and the results showed that Harold Dare was in at least 99 44/100% perfect condition for this tremendous trial, the mechanics were already warming up the motor of the transport for the flight.

At exactly 9:00 a. m., the *Spread Eagle* took off from Bandy Field amid the cheers of a huge multitude; and as the airship vanished from sight, with it went the good wishes of the entire world. As President Neverre had predicted, the attention of the entire public was turned upon this flight; but now that Harold Dare in person was known to be conducting the investigation, the attitude was one of confident expectation and keen, friendly interest, rather than of pessimism and hostile curiosity.

In the cabin of the *Spread Eagle*, complicated instruments crammed the luxurious compartment to capacity. The six scientists worked unceasingly over their apparatus, for each had a multitude of details to engage his attention. The radio operator continually clicked his key, as report after report went out to the home office, there to be summarized and relayed to the waiting world. Harold Dare sat at the controls,

(Continued on page 1373)

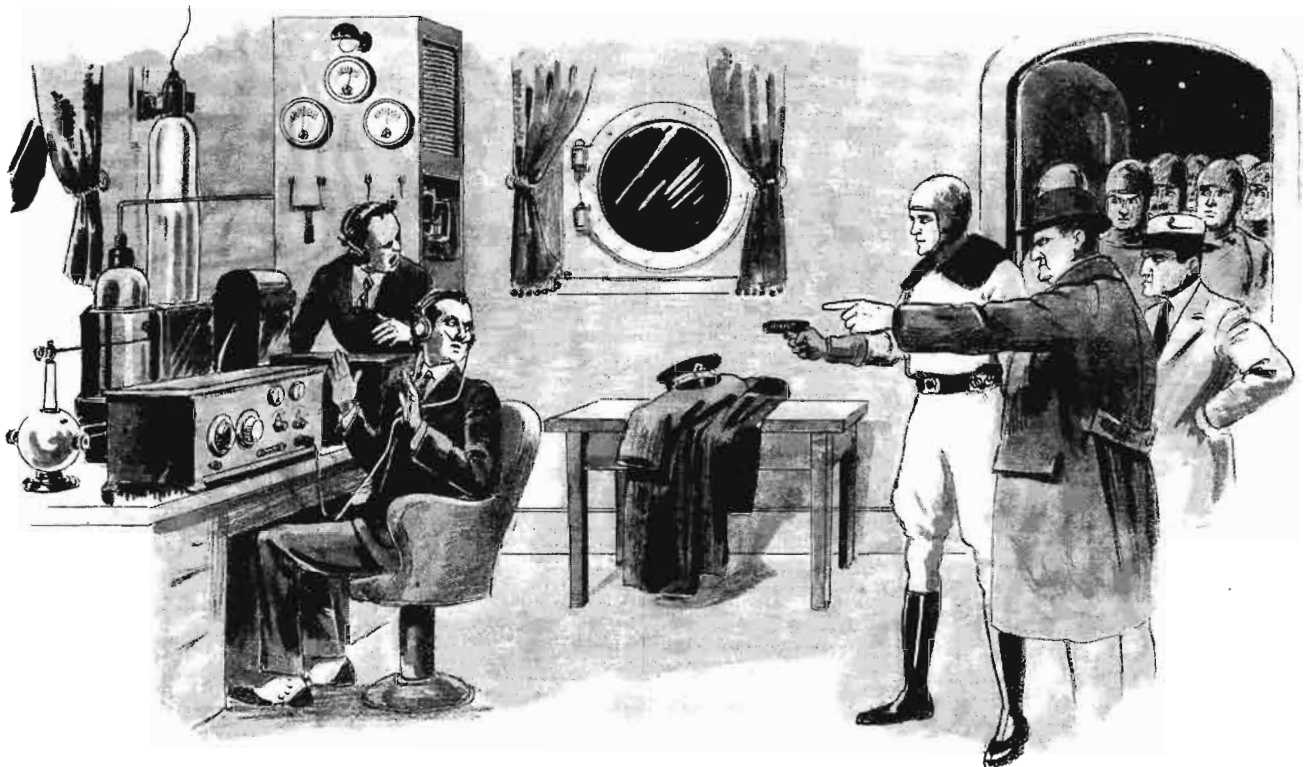

The villain whined—to face a sinister row of blue-muzzled automatons. He raised his hands slowly skyward. "Am I un-

done?" he demanded. "Is this like another scenario, in which right always triumphs in the last reel?"



## You Can't Buy Location

Editor, RADIO NEWS:

After patiently waiting for the March issue, I started to read it; and when I got to page 980 ("Encircling the World with a Two-Tube Set") I read the article three times over, until my head began to swim. Please tell me, how do they get that way?

I have a 50-foot tower, and three smaller ones to keep the aerial from swinging; an aerial 156 feet long with a straight lead-in to the set No. 12 (enameled wire); a ground on a pipe 15 feet into watery clay and one on a lead pipe in wet clay. Everything O.K., "lossless," insulated, etc., etc. I have tried about every set known; supers and others (price no object) and when I get KFI it must be under excellent conditions. I have about \$1,500 invested in the best radio parts, in fact, anything I want. I have had radio editors galore at my place, plus engineers of all grades to improve reception. All I use now is a 3-tube regenerative set, and I get the same results.

I like RADIO NEWS, and have had several helping hands, so to speak, from your technical engineers; for which I must thank you and your staff. I think your next edition will be six inches thick if you publish all the letters you will receive this month, about this one article alone. Just the same, I am one of your boosters, and always find something new in your columns.

JAC. J. DIEDERICH, O.D., D.C.,  
1615 West 51st Street, Chicago, Illinois.

(Yes, we have received several letters asking "How Come?" We do not know—nobody does yet—why one location is so favorable for reception and another is not. We know that a radio listener near the sea is apt to get much greater distance, one in the mountains much less; but there are many mysteries in the propagation of radio waves. If we could have a detailed map showing the field-strengths, all over the world, of a super-power station, we might be able to analyze more closely than ever before the subterranean composition of the earth and the distribution of its metals; but this is just a speculation at present. We will say, however, that the article named above contained the findings of a trustworthy and experienced correspondent as to the facts therein set forth.—EDITOR.)

## English Opera or None

Editor, RADIO NEWS:

I am a constant reader and eagerly await each issue; to me one of the most interesting sections is the "Letters from Home Radio Set Constructors." Having been a builder of sets for about six years, I notice that most manufacturers, set-builders and fans keep harping about the qualifications or disqualifications of such and such a set or parts. A short while back, the greatest enemy of radio reception was none other

than Old Mr. Static. Well, all this is O.K., and tends to improve radio reception in general. But your magazine and all the rest of them, including the home-set builders who contribute these letters, and the parts manufacturers, have overlooked one of the main troubles.

To my mind and way of thinking, the greatest menace and most disgusting part of radio reception is no other than this: when you tune in, sit back in your easy chair—and, all at once, some Antonio Rubeeles starts to force about 45 minutes of "Maladia qua qua Spagettio!" I ask you, do you know what he is trying to say? Or sing? I think they call it "Grand Opera."

At any rate, I was born right here in the U. S. A. and, like a million or more other

4:14 a. m.: Two Songs (man) with piano. Interference prevented further reception.

Sunday, Feb. 5. Wavelength 30.9 meters: Time 3:45 a. m. to 4 a. m. Dance music R4. Mushy, probably due to over-modulation.

(All times stated are South African Time, 7 hours ahead of E. S. T.).

I have very often received your signals, but would not report until I had definitely received your call sign.

I also enclose a "Broadcastatic". The other evening, Gordon Bird, the announcer at the Cape Town Broadcasting Station, had just wished an old lady listener very many happy returns of the day, it being her 82nd birthday. He then announced "we are now going over to the Alhambra Picture Theatre whose orchestra will entertain you." Over went the switch and what do you think we heard? The Dead March in Saul!

As I am a regular reader of RADIO NEWS, reading "Putting Broadway on the Air," in your January number, was like being among old friends; as I have heard all the "Old Gold" broadcasts and thoroughly enjoyed them; "Just Fancy" being particularly good. Wishing you continued success.

C. R. SLINGSBY,  
Scriven, Thelma Road, Claremont,  
South Africa.

## 'Scuse Us for Living

Editor, RADIO NEWS:

In your latest issue I noticed a very interesting letter from a Mr. Chambers of little old N'York, in which he seems to give the Comm. Op. the "razz." Might I say a word in defense of the Commercialists?

Possibly, Mr. Chambers had not thought about the fact that, if it wasn't for us commercial ops., there would be no broadcasting.

I am a commercial operator and am at present in the broadcasting game struggling with the static and trying to put over entertainment for the listener; and I would like to say that, due to the fact that there is a heavy penalty for malicious interference (and numerous other reasons, such as getting bawled-out by the coastal station "brass pounders") there is practically no unnecessary "fat chewing" between operators in the commercial game—unless it is between a couple of "boots" that haven't gotten their sea legs yet, but after getting a very "polite" request from some coastal station to pipe down, discontinue this practice.

There are some ships afloat that have spark sets which cause some interference in New York harbor; especially if these home-made sets are so made that all stations come in without turning either condensers or inductances, especially on frequencies near the commercial band.

I grant you the fact that the magazine should not be for the commercial operator; but I do think it would be a good thing to have a page or so devoted to our problems,

(Continued on page 1384)

*THIS page belongs to the readers of Radio News. It is theirs for the purpose of discussing fairly and frankly the needs of broadcasting from the standpoint of the great public who listen in. The letters represent, not necessarily the editorial opinion, but that of the writers; who are, in the editorial belief, fairly typical of groups of opinion among the radio public. Make your letters concise and offer constructive criticism when you can; remembering always that there is something to be said for the other fellow's side.*

Address The Editor, RADIO NEWS,  
230 Fifth Avenue, New York City.

American radio owners, can not, do not, and will not understand it. If the broadcasters are putting this "qua qua" stuff on the air, won't you kindly use your good efforts and tell them—if they must put it over on us, give it to us in English so that we can understand it. Let's hear from some more radio fans on this. Yours for understandable reception.

C. ADAMS,  
89 Wyoming St., Mt. Washington Sta.,  
Pittsburgh, Penna.

("Everyone to his taste," says an old proverb; and Mr. Adams' poison is meat to some radio fans. Whatever the success of the endeavor here to promote opera in English, it may be remarked that the great thrill of the European radio fan is to tune in as many languages as possible—irrespective of how many he understands. What is the role of operatic broadcasting?—EDITOR.)

## From the Cape to Broadway

Editor, RADIO NEWS:

It might be of interest to you to know, that your station WRNY has been heard by me at fair strength. My log reads as follows:

Sunday, Jan. 29. Wavelength 30.9 meters: Time 4:06 a. m. Orchestra (Morse QRM Commercial) Call R. S.



FRANKNESS VS. FRANKFURTERS



MAYER: "That hour sponsored by the Schmidt Wiener Corporation isn't up to much."
BAYER: "Well, I always said it was the 'wurst' on the air!"

"Radio Night Life"

At the Waldorf we dine,
Where the music's like wine;
Then toddle around to some show,
Where there's statuesque pouches
On tropical beaches,
And the seats are six dollars a throw!

And from there we fling out,
With a laugh and a shout,
En route to a gay cabaret:
Where we sing and we dance,
Like two fools in a trance,
'Til almost the breaking of day.

'Tis a wild sort of life,
For myself and the wife.
This nocturnal cruising about;
But we'll follow the pace
To the end of the race,
If our radio'll only hold out!

For the total expense
Of this pleasure intense,
Is the loss of a few hours' sleep;
Plus a slight wear and tear
On the old rocking chair;
You'll admit 'tis exceedingly cheap.

All the joy in the world,
Is now freely unfurled,
By artists of talent and fame;
And life's worth the living—
One endless Thanksgiving—
Since we got in the radio game!

—Roy Coleman.

SO SAY WE ALL!

Mrs. Jones: "So you have two radio sets at your house?"

Mrs. Brown: "Yes; the one my husband repairs himself, and the one we get our music on."



HOW HE COULD TELL

HARRY: "How long have you been married?"

HAROLD: "Let's see, I bought this loud speaker for my radio set four years ago."

—Ollie Meloy.



LITTLE PITCHERS HAVE A FINE PICK-UP

LITTLE PERCY: "Our garage man has a fine radio set, mamma."

UNSUSPECTING MAMA: "What makes you think that, dear?"

LITTLE PERCY: "Why, I heard him say he would get hell when he went home tonight."



WHERE NIGHTS ARE SIX MONTHS LONG



EXPLORER: "I knew a fellow who listened to fifteen hundred bedtime stories in one night."

LISTENER: "He must have been a lunatic."
EXPLORER: "No, he was an Eskimo."

MID-WEST, PLEASE NOTE

Mrs. Phanne: "What lovely music! I've a mind to send that station an applause card."

Mr. Phanne (wearily): "Yeah, send a card to all six of 'em!"



THIS page is devoted to humor of purely radio interest; and our readers are invited to contribute pointed and snappy jokes...

DANGERS IN DEFERRED DEBTS

"This is the Blah Radio Company, broadcasting from station FOB. We are speaking for the agent in your town: 'Unless all back payments are made on sets bought, your name will be announced from this station Saturday night.'"

Before Saturday a bank had failed, five men had committed suicide, and several attempts had been made to dynamite station FOB.



REASONABLY TRUTHFUL

"Have you an extra false set?" asked the dentist of a patient.

"Oh, no, replied the patient, 'mine is a four-tube set.'"

—E. H. Foley.

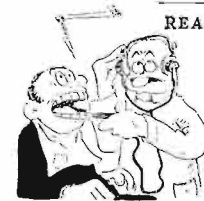

RADIO RHYMES.....No. 8



FROM OUTWARD SIGNS IT'S EVIDENT THAT JUNIOR IS ON MISCHIEF BENT...

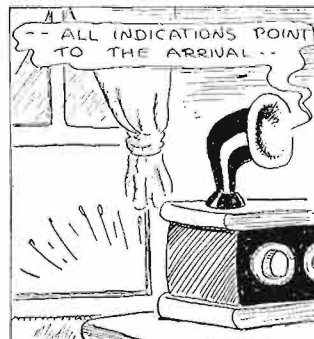

SOME VILLAINY IS UNDER WAY... OR MAYBE SOME NEW FORM OF PLAY...

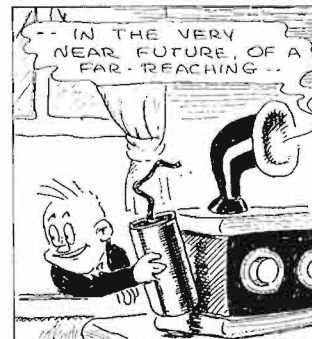

AH!... NOW WE SEE THE MATTER CLEAR!... A RASH EXPERIMENT... WE FEAR...



HE'S MERELY TRYING TO PRESENT AN "ILLUSTRATED" NEWS EVENT!

# The "Electric Brain" and Its Language



A New Device Which Turns Speech Upside Down and Back Again, Defying Eavesdroppers

By G. C. B. Rowe

**S**UPPOSE you should meet a friend whom you had not seen in a long time, and ask him where he was earning the weekly pay-check. If he answered that he was employed at the "Play-a-fine Crink-a-nope," you would more than likely glance at him askance and murmur something about an immediate engagement. However, that would be nothing to be alarmed over; for your friend could tell you that he was speaking a new language, understandable only to electrical brains and incomprehensible to the human ear.

This new language is the result of some very interesting experiments performed at the Bell Telephone Laboratories, New York City. In the search for some method of making secret communication possible, the idea was suggested that the high and low speech frequencies be "inverted" or transposed so that the higher frequencies would replace those at the lower end of the band and *vice versa*. In other words, the pitch of the vocal sounds is "inverted," so that, for every sound in ordinary speech, there is substituted another, whose pitch is high where the original is low, or low where the original is high. (See Fig. 1). The pitch of the "inverted" frequency is *exactly as far below a certain fixed frequency, which we call the "inverting point," as the original is above zero.*

**LEARNING SPEECH UPSIDE DOWN**

By using the "inverting" apparatus, the

common English words spoken before a microphone are reproduced from a loud speaker, as totally different sounds which bear no apparent relation to the original. They may, however, be translated back into English by passing them through another "inverting" apparatus which sets them right side up again, so to speak. In addition to this, the experimenters with this apparatus have learned by experience the nature of the sounds corresponding to a word after it has been inverted; so that they are able to imitate some of these sounds before the "inverting" apparatus and cause them to reappear as English.

At this point it must be explained that speech is composed of very complicated sounds. The fundamental note which we call the pitch of the voice is emitted from the vocal cords, and maintains its frequency fairly well under ordinary circumstances. But we cannot carry on a conversation by "sounding our 'A,'" though we might conceive the use of code for an I.C.W. message. The pure flow of sound in the throat and mouth is interrupted and modulated by the motions and vibrations of throat, palate, tongue, teeth and lips, causing what we call "consonants" and "vowels." The letters S and Z, for instance, introduce noticeably high pitches into the voice; so that they are most difficult to understand over the telephone or the radio. For that reason, the frequency-components of speech

cause it to spread over a band very much wider than that we would attribute to the throat as a musical instrument; it resembles in that way music whose fundamental notes do not rise above say 4100 cycles, but

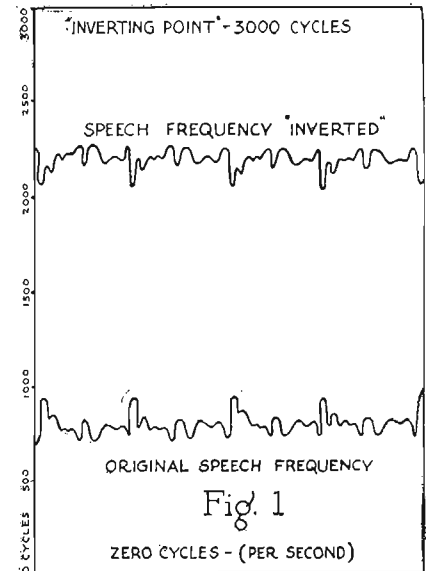

*This graph will show exactly how the sound of "ah" appears in an oscillograph at ordinary speech frequencies; i.e., between 800 and 1,000 cycles. The inverted sound is shown between the frequencies of 2,000 and 2,200 cycles.*

whose harmonics keep on until they are far above the ability of the human ear to detect. These characteristics of speech and music are turned "topsy-turvy" in the "inverting" apparatus.

**THE TRANSLATING MACHINE**

In the formation of "inverted" speech, the *modulating frequency* acts somewhat in the same manner as does a convex lens in inverting the image of an object; that is, the top appears at the bottom and the bottom at the top. It is possible to use any frequency for this "inversion;" but, in order to have the resulting sounds within the usual speech-band, a frequency must be chosen that is just slightly above the normal speech range. The apparatus now in use employs three thousand cycles as an "inverting point." There are, of course, frequency components above three thousand cycles in ordinary speech; but these are carefully filtered out before the speech is sent to the inverting apparatus.

Let us assume a speech range of 100 to 2900 cycles and an inverting frequency of 3000 cycles. After the frequencies have been inverted, they will occupy the same band—100 to 2900 cycles—but in the *reverse order*. This is because each "inverted" frequency is the resultant obtained by subtracting the original frequency from the

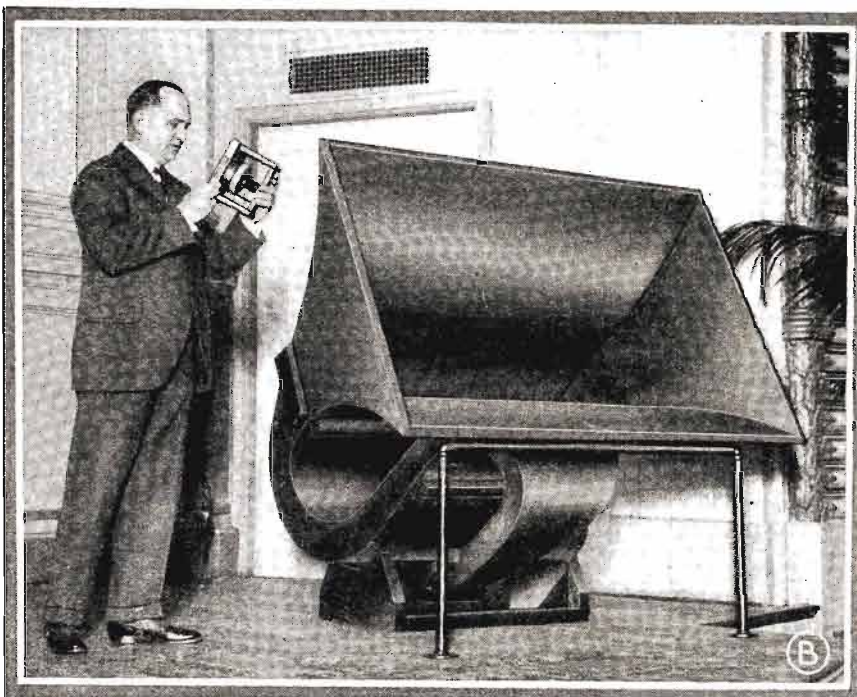

**Fig. B.** Dr. Grace holding the loud-speaker unit which actuates the 14-foot exponential horn, the convolutions of which are clearly seen.

© P. & A. Photo



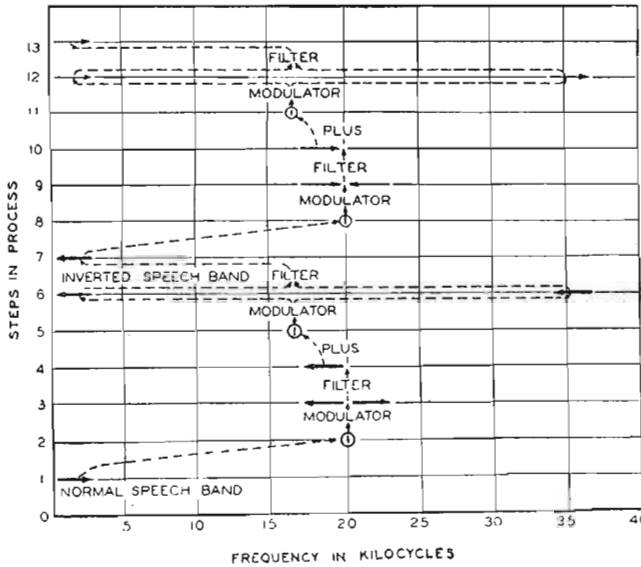

Fig. 2

At the left, beginning at the bottom, we have shown the frequency changes which speech undergoes when it is inverted and restored to its original condition. At 1 the 3,000-cycle speech band, which modulates the 20-kc. carrier frequency shown at 2; the resultant currents, at 3, are filtered at 4, impressed on a 17-kc. carrier at 5, and passed through the filter at 6, leaving a band from 0 to 3,690 cycles, but "inverted," at 7. The same processes, in the same order, restore the speech to its original frequency, at 13. Arrows pointing to the right indicate the normal order of speech modulation; those pointing to the left, "inverted" modulation.

"inverting" frequency, 3000 cycles. That is, if we were to sound on the piano "Middle C," which has a frequency of 256 cycles, the resulting tone after the "inversion" would be 3000 minus 256, or 2744 cycles. Therefore, a person speaking in the usual lower tones hears his voice emerge from a loud speaker after "inversion" as a high-pitched squeak, which is varied every little while by a low grunt, due to overtones in the original speech.

THE NEW DICTIONARY

To one hearing "inverted" speech for the first time, it sounds like gibberish, worse than any barbarous language that could be imagined. However, if one listens carefully, it is possible to distinguish words and phrases. For example, the words in the first paragraph of this article, "Play-a-fine crink-a-nope," when spoken into a microphone connected to the inverting apparatus, emerge from the loud speaker as "Telephone company." Another scrambled phrase is "Oy-an-son play-a-fine Ace-cil-o-fin," which, when translated by the electrical brain becomes "Illinois Telephone Association."

When music is "inverted" the sounds are those usually attributed to the wailings of the damned; they are enough to drive any lover of music mad. When the "music" of a jazz band is "inverted" the resulting sounds are just a little worse than usual, with the deep beats of the drums now high in the scale; the violins, flutes, and piccolos sound like the ordinary bass instruments, but, throughout the whole cacophonous outburst, can be sensed the beat of the syncopation.

THE "INVERSION" PROCESS

In the actual apparatus developed by the Bell Telephone Laboratories, two modulating steps are used, one at twenty and another at seventeen kilocycles; which give the same result as if a single modulation at three kilocycles were employed. In a single process of modulation, certain distorting frequency-components are introduced unavoidably, and are difficult to filter out when the modulated and the modulating frequencies are too nearly alike; as would be the case when a voice band of from one to twenty-nine hundred cycles modulates a three-thousand cycle frequency. By allowing the voice band to modulate first a

twenty-kilocycle frequency, the distorting frequencies are eliminated.

The various changes undergone by the sound-frequencies in the "inversion" process may be readily seen from Fig. 2, in which are shown all the steps from the time the original frequencies are superimposed upon the first modulating frequency until they are "inverted," and then "reverted" back to the normal sounds. At the left of the diagram are the various processes numbered; and along the bottom are indicated the frequencies at which the processes occur. The arrows pointing to the left indicate that the frequencies at that particular stage are "inverted," and those pointing to the right show the opposite to be true. The normal speech in No. 1 (a band of frequencies 100 to 2000 cycles wide) is impressed on a frequency of 20 kilocycles at No. 2 (20,000 cycles indicated by (I), and produced by an oscillator) which it modu-

lates, resulting in two bands 2800 cycles wide of each side of 20,000 cycles, No. 3. The upper band is filtered out in No. 4, which leaves an "inverted" band for modulating the 17-kilocycle frequency, No. 5. In step No. 6 we have as a result two more frequency bands, both "inverted;" the upper one is once more filtered out and leaves a band of audible frequencies from 100 to 2900 cycles, but with the original frequencies inverted. (No. 7.)

The process for reinverting these audible frequencies back again into understandable speech is carried out in exactly the same way as in the inversion. (See steps No. 8-13 in Fig. 2.)

THE APPARATUS USED

Let us look for a moment at the equipment needed to demonstrate a system of this type. In Fig. A is an orthophonic talking machine on which records of "inverted" speech are played. A machine of this kind is employed, so that as wide as possible a band of frequencies will be reproduced, thus giving the most natural sound to the voice. To the condenser microphone, which is of an ultra-sensitive type, is connected the "inverting" equipment, or the "electrical brain." At the rear of the stage may be seen the audio-frequency power amplifier, which in turn is connected to the large exponential horn shown in Fig. B.

When an "inverted-speech" record is played on the machine the result is a noise sounding like a mixture of Chinese, Russian, Siamese, English and a few others thrown in for good measure. When the microphone is held in the position shown in Fig. A, and the doors of the cabinet are slightly closed, instead of the babel of sound there issues from the large horn clear, understandable English, completely drowning out the noises coming from the talking machine. When the microphone is

(Continued on page 1381)

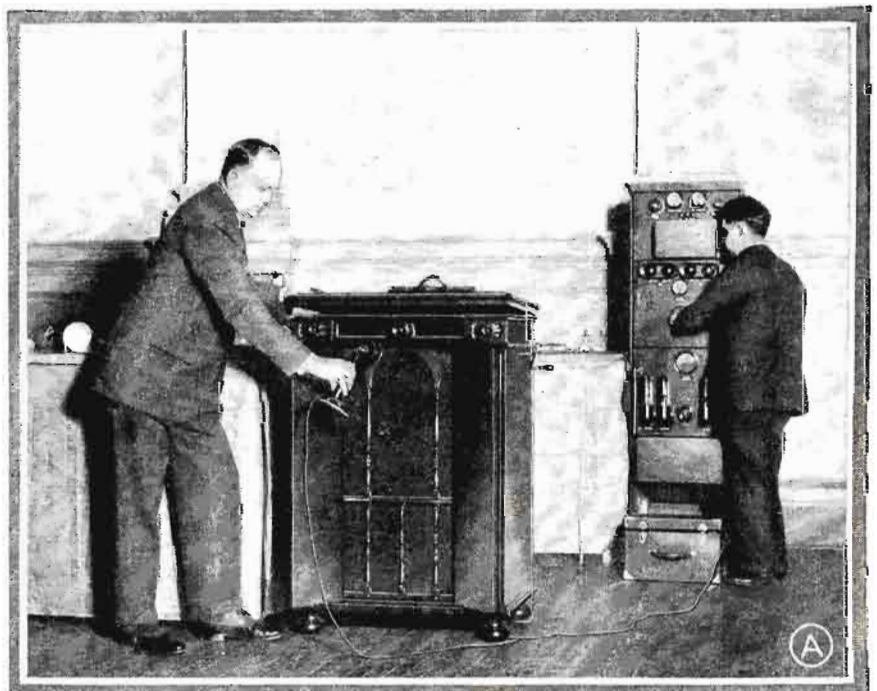

Fig. A. Dr. S. P. Grace holding the condenser-type microphone before the talking machine's horn; thus picking up the inverted speech, which goes to the power amplifier in the background.



# Television

Under this new heading, RADIO NEWS will publish each month descriptions of the latest developments in the extremely interesting field of television.

## England Goes in for Television

London Department Store Sells Apparatus With Which a Crude Television Receiver Can Be Built

ONE of the best-known department stores in the world, Selfridge's of London, recently advertised that it has on sale apparatus from which can be built television receivers which operate on the principles developed by John L. Baird, the Scotch inventor. (It will be remembered that an article appeared in the May issue of RADIO NEWS, describing the successful transmission of an image across the Atlantic Ocean by Mr. Baird.)

As soon as this announcement was received by Radio News a cable was despatched to Selfridge's for further informa-

	English Shillings and Pence	U. S. A. Dollars
Interrupter disc .....	7 6	1.83
Spiral disc .....	15 0	3.66
Selenium cell .....	20 0	4.88
(Another type is listed at 10 shillings)		
Two motors ..... (Each)	21 0	5.12
Transmission mirror, 10 cm. focussing type .....	7 6	1.83
Reception mirror, 10 cm. focussing type .....	7 6	1.83
Neon lamp, without series resistance .....	3 3	.79

Reception screen, ground gelatine (about 4 inches square) .....	1 0	.24
Projector lamp, 500 watt (to suit voltage) .....	30 0	7.32
Control rheostat .....	3 0	.73
Batten holders (screw cap), two .....	1 8	.41

### A PRIMITIVE MODEL

In order to check up further, RADIO NEWS communicated with its London correspondent, and he was requested to get as much information about these television receivers as possible. Portions of his report are printed herewith, and it certainly is far from enthusiastic.

"The 'Televisor' described is a very crude piece of work; it serves as both transmitter and receiver; to avoid synchronizing, the two discs sit on the same spindle.

"In practical construction, this 'Televisor' model appears to offer many difficulties to the fan; he is asked to invest also in a four- or five-stage audio amplifier to boost up the received impulse so that the impulses can flash a neon lamp! The 'B' voltage required for this purpose is given as four to six hundred volts; as the power tube specified is a most expensive transmitting tube.

"I am afraid that the Baird system is hopeless, after all. It cannot give sufficient detail and, if you glance through recent

(Continued on page 1389)



Left, the television department in Selfridge's, London. Below, we have one of the store's windows showing the television apparatus.

tion, and it was learned that the receivers advertised are designed to receive only silhouettes, not detailed pictures. This, of course, was due to the fact that the selenium cell, employed to transform the received light energy into electrical energy, has not the necessary speed for the production of a more detailed picture. The improved Baird and other television transmitters use photoelectric cells, which have less lag, and therefore can record more details.

The price of the necessary parts is given, in a lump, as five pounds seventeen shillings (\$28.50); but these are on sale only in Great Britain and will not be exported from there to fill orders from America. For the most part, the components are simple in nature and can be assembled very easily by the amateur. The list of parts for Mr. Baird's early-model receiver is given as follows, with the advertised prices for separate items:

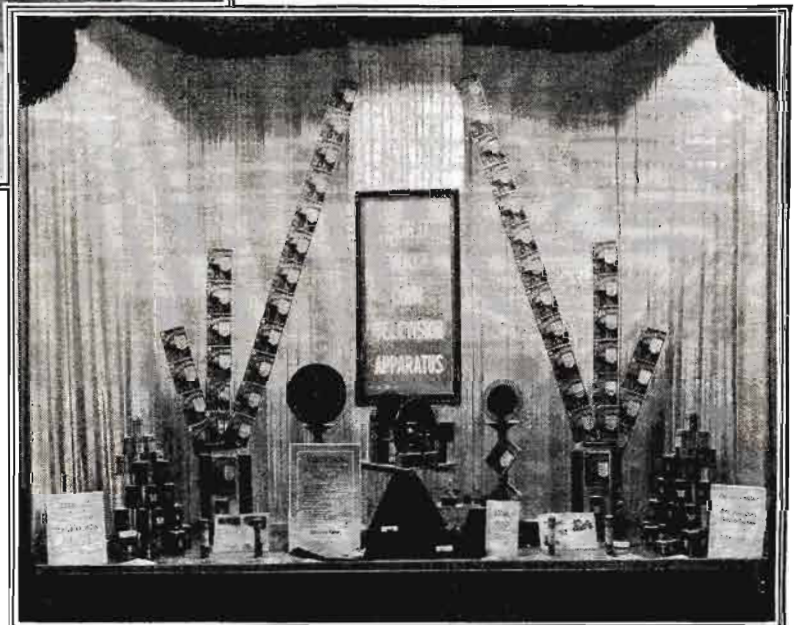

# Latest Novelty Developments in Radio



Harry N. Marvin, of Rye, N. Y., has perfected a receiver, which can tune in, exactly, any one of nine broadcast stations by throwing a key or pushing a button. The tenth control permits the set to be tuned by hand in the usual manner. The inventor is holding, in the illustration above, an "automatic dial," which was the forerunner of the perfected system. At the right, Mr. Marvin is explaining his system of tuning to Rear Admiral Bradley A. Fiske, a leading naval inventor.

"Bill" Ray, announcer at station KFWB, Hollywood, beneath the microphone of a new type in use there.

Edmond Lambert, a French radio engineer, has designed the one-tube regenerative receiver shown above. Stations over 400 miles have been received, using an indoor aerial. The coil toward the thumb in the upper illustration is a tickler, and the other one-half of a variometer. Binding posts, from top down: "Aerial," "A+," "A- B-," and "Phone" to "B+." The tube fits into the four panel holes. When not in use, the set folds up, as shown at the right.

# Radio Measures Human Nerve Impulses

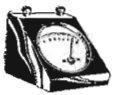

A Description of the Radio Apparatus Used in Experiments for Amplifying and Recording These Minute Currents

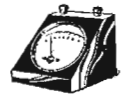

By Theodore A. Hunter\*

SCIENCE had much to be thankful for when the vacuum tube was invented, for this obedient servant has solved many an intricate problem which would have remained unanswered without its aid. It has now found a relatively new use in research investigations concerning the nervous system of the human body. Previous investigations have made use of the vacuum tube for amplifying nerve impulses (or "action currents," as they are generally known to physiologists); but, so far as the writer knows, the present paper sets forth methods and results which are somewhat in advance of those which have been described heretofore.

The average radio fan can readily follow the methods used in amplifying and recording the nerve impulses; and, by making a few simple connections within his radio set, according to the directions given, he

Fig. 1 shows the amplifier's circuit diagram. T1 is an input transformer which has a center-tapped primary. This center tap is used to balance out voltages induced in the input wires due to stray electromag-

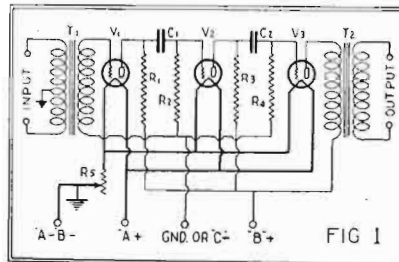

Circuit of the three-stage audio-frequency amplifier used in the experiments described in the accompanying article.

netic and electrostatic fields. V1, V2 and V3 are tubes having an amplification constant of 30 and are of the 240 type. R1 and R3 are fixed resistors and have a value each of about three megohms. Similarly R2 and R4 have each a resistance of about 250,000 ohms. T2 is an output transformer built by winding about 80 turns of No. 18 D.C.C. copper wire over the winding of a 30-henry choke coil. This matches the plate impedance of the vacuum tube (V3) to the impedance of the oscillograph's vibrator element. Resistance R5 is a 6-ohm rheostat. The grid return may utilize the drop in potential across R5 for the grid bias, or a "C" battery may be used. Usually the negative voltage drop due to R5 is sufficient for good results. The "B" voltage used on the plates is 180. Fig. A shows the general arrangement of the parts. A brass panel is used as a common ground connection.

Brass strips, one-half inch wide by two inches long, covered with canton flannel, served as electrodes. Before each experiment they were soaked in a saturated salt solution. Fig. B shows the electrodes in place on the forearm with the wires connected to them.

The oscillograph is probably the most flexible recording instrument which the electrical engineer has at present. Frequencies as high as several thousand complete vibrations per second are recorded easily.

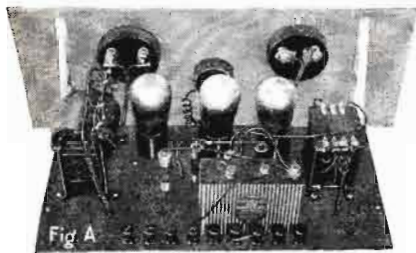

A rear view of the A.F. amplifier; the brass panel is employed as a common ground connection. See Fig. 1.

may amplify nerve impulses sufficiently to be heard in an ordinary headset.

### THE APPARATUS

The apparatus finally developed, for use in the experiments described below, consists of a three-stage resistance-coupled audio amplifier, a portable three-element oscillograph, a vacuum-tube oscillator, and a special signal circuit.

The apparatus finally developed, for use in the experiments described below, consists of a three-stage resistance-coupled audio amplifier, a portable three-element oscillograph, a vacuum-tube oscillator, and a special signal circuit.

A three-wire twisted conductor was used to connect the input of the amplifier with

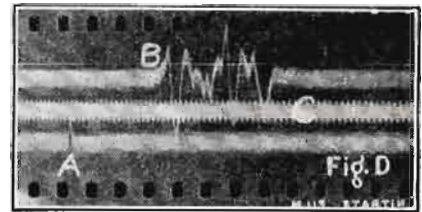

The photographic record of a nerve impulse set up by striking the leg just below the knee. A, time when the tendon was struck; B, time when the nerve impulse reached the muscle. The interval may be gauged by the 1/1000-second cycles shown at C.

### THE OSCILLOGRAPH

Fig. 2 is a simplified sketch of an oscillograph galvanometer. Essentially, it consists of a single loop of wire, placed between the poles of a permanent magnet, which supports a small mirror. This part of the galvanometer is called the vibrator element. A ray of light is focused upon the mirror and reflected on a moving photographic film. When no current is passing through the vibrator-element conductor, the reflected beam of light causes a straight line to be recorded on the film. As soon as a current is sent through the vibrator element, one wire, A, will move in a direction opposite to that of wire B, causing a rocking motion of the mirror and of the beam of reflected light. Thus, any change in the current impressed on the input leads causes a corresponding shift in the position of the spot of light on the film. This, then, affords a means for recording, photographically, an electrical current. Fig. C shows a close-up view of an oscillograph's vibrator element. A and B are the fine wires forming the loop; C, the tiny mirror; D, one of the supporting bridges; and E, the roller for equalizing the tension on the wires.

Fig. D shows a record taken by the os-

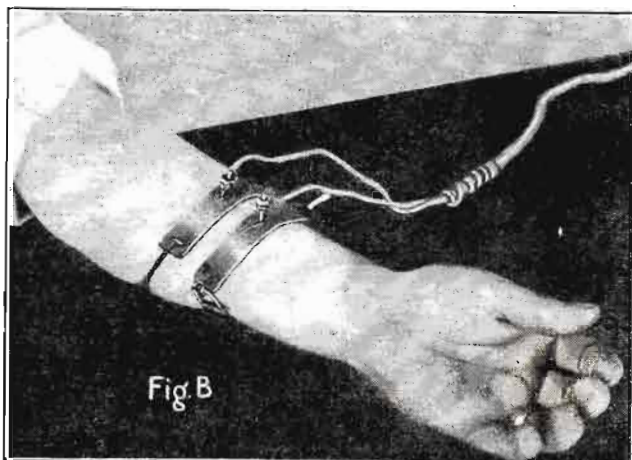
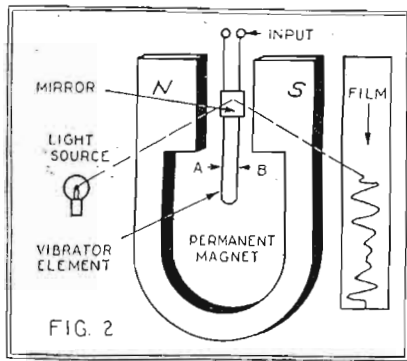

Fig. B

The input of the amplifier shown above picks up the nerve impulses, in the forearm, through these electrodes of brass covered with cotton flannel, which is soaked in a saturated salt solution before each experiment. The complete apparatus, somewhat crowded together, is shown on the page opposite, with a subject harnessed for test on both arms at once.

\*Department of Physics, University of Iowa



The minute mirror is cemented to the loop of wire AB. A ray of light is reflected from the mirror to a photographic film, such as shown in Fig. D, and its oscillations are registered as a wavy line.

cillograph, which indicates the length of time elapsing between the stimulation of the patellar tendon (which is the tendon or sinew just below the knee cap) and the production of nerve impulses in the muscles of the leg. A is the instant of time at which the patellar tendon was stimulated and B the instant of time at which the nerve impulses arrived at the muscle. C is a time-line of 1000 complete cycles per second, produced by a vacuum-tube oscillator.

In order that a signal circuit might be used near the amplifier's input, it was necessary that it consume a very small amount of power. Fig. 3 shows the signal-circuit wiring diagram. B1 is a 1½-volt dry cell which is used to charge the 0.1-mf. condenser C1, by closing the contact K1. Contact K2 consists of a thin brass strip, placed over the patellar tendon, and a metallic hammer which is used to stimulate the patellar tendon by striking the brass strip.

When this contact is made the power previously stored in condenser C1 discharges through R1, causing a change in the plate current of the 199 vacuum tube through the primary of transformer T by virtue of the change in potential in the grid circuit. The amount of power consumed by the signal circuit is sufficiently small to cause no appreciable disturbance in the amplifier circuit, as shown at A in Fig. D. Transformer T is similar to transformer T2 in Fig. 1.

The apparatus could not be bunched together because of interaction between the circuits; therefore it was located so that the amplifier and oscillator were about forty feet apart, with the oscillograph placed about midway between the two. The subject was located near the input of the amplifier. Fig. E shows a picture of the apparatus bunched together for pictorial purposes. In this case the set-up for measuring the time of arrival of the nerve impulse at the two forearms is shown. Two amplifiers are needed for this particular experiment.

HEAR YOUR OWN NERVES

The radio fan may detect these nerve currents from his own radio set. An average radio set has the equivalent of two stages of transformer-coupled amplification. Your radio set should have at least this much amplification, in order that the nerve impulse may be heard in a pair of headphones when they are connected in place of the loud speaker.

First disconnect the detector's "B" lead from the battery. Then attach a wire to

this lead which you have just disconnected, for one of the input wires; second, remove the detector tube; third, connect a wire to the plate terminal of the detector-tube socket for the other input wire. You now have in your hand two wires which run to the plate impedance of your radio set, whether it be a resistance-coupled, impedance-coupled, double-impedance-coupled, or transformer-coupled amplifier that you are using. Now place the bare ends of the input wires upon the tongue, after making sure that no voltage exists between the input terminals. Place the bare ends of the input wires upon the tongue, after making sure that no voltage exists between the input terminals. Place the bare ends of the input wires upon the tongue, after making sure that no voltage exists between the input terminals.

You should now hear either a squealing noise in your headphones or a noise which

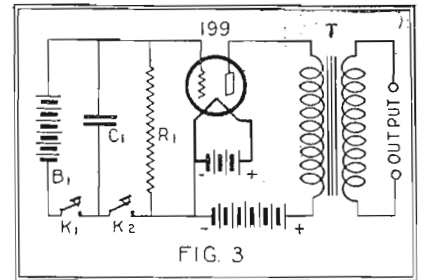

The schematic diagram of the signal circuit. B1 charges C1 when K1 is closed. K2 is the brass contact, placed over the muscle under observation, and a hammer which strikes it.

The squeal should have disappeared, in the last case, and upon relaxing the tongue you should not hear nerve impulses; while upon protruding it you should hear them. In case you have an A.C. set the A.C. hum may be sufficiently great to completely suppress the sound of the nerve impulse produced in the headphones.

PSYCHOLOGICAL TESTS

Probably the most outstanding discovery made with this equipment is that of finding a close relationship between intelligence and speed in conduction of the nerve impulse in a reflex arc. (See note at end.)

Briefly, this research consisted of obtaining a large number of records on different individuals, such as the one shown in Fig. D. These records showed a reflex time varying from .011 to .027-second. In other words, conduction over a "reflex arc" in one individual was two and one-half times as fast as conduction over the similar reflex arc in another individual. The bright individual has a short reflex time, while the dull individual has a long reflex time.

This, then, means that the person with a fast reflex time probably is better able to associate ideas; inasmuch as he does not have to retain them for any great length of time. It may be compared to a movie film. If it is running too slow, the story

(Continued on page 1381)

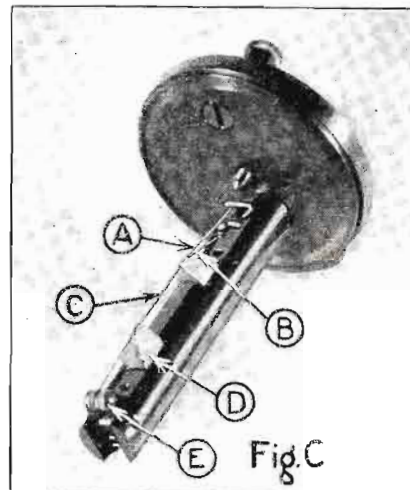

A and B are the wires forming the vibrating loop; C is the minute mirror; D, supporting bridge for the wires; and E a roller equalizing the tension on the wires.

sounds not unlike that of rain beating on a tin roof. If you hear a squeal in the headphones give them to some one else to wear; if you still hear a sustained oscillation place a low-resistance leak (from 1,000 to 10,000 ohms) across the input circuit.

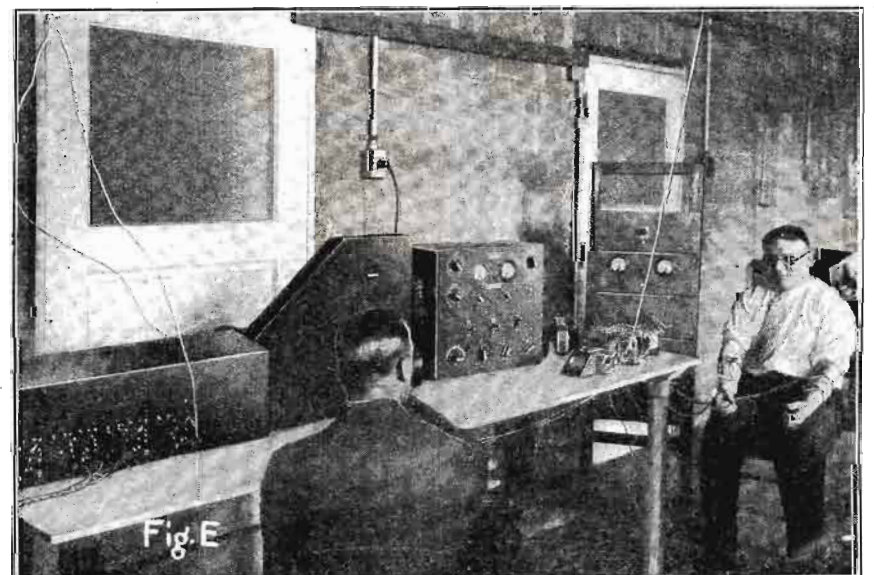

The oscillograph is in the long box on the left, the film is in the center sloping box; the oscillator is next. On the table next to the patient is the signal circuit apparatus and the amplifier is in the rack at the table's end.

# The Radio Beginner

## An Audio Amplifier for the "Extension" Receiver

As mentioned in the article describing its construction, the simple "Extension" two-tube receiver (which was featured in the "Radio Beginner" department of the May number of Radio News) may be made to operate a loud speaker if it is equipped with a suitable "audio amplifier." The two-tube hookup, as it stands, yields excellent results on headphones; but, once the set has been demonstrated with their aid to the individual members of the constructor's family, the desirability of a loud speaker becomes very evident. It is possible to connect several pairs of headphones to the set, but this arrangement will be far from satisfactory.

The purpose of an audio amplifier is to take the comparatively weak voice and music impulses, as they are heard in the phones connected in the plate circuit of the detector tube (V2 in the receiver part of the circuit diagram and in the illustrations in the May number), and to amplify them until they are of sufficient strength to operate a loud speaker. In the simplest and most reliable form of amplifier, this work is performed by two vacuum tubes and two instruments known as "audio-frequency transformers." The tubes are exactly like those used in the two-tube receiver; except that one of them possesses special characteristics that make it especially suitable for amplifier purposes.

### THE AUDIO-FREQUENCY TRANSFORMERS

The "audio-frequency" (usually shortened into "A.F.") transformers are heavy devices consisting each of two coils of fine wire, usually wound over each other and around an iron core. Each coil contains several thousand turns of hair-like wire. One is called the "primary," the other the "sec-

ondary." The secondary has, usually, from two to ten times the number of turns that are wound into the primary; this numerical relationship being termed the "turn-ratio" of the transformer. The transformers employed for amplifying voice and music "signals" in a radio receiver have fairly low ratios; 2 to 1, 3 to 1 and 5 to 1 are the

devices between the vacuum tubes can be explained briefly. The primary of one transformer (T1) is connected in place of the headphones to the Extension receiver; so that the plate current of the detector tube, carrying the voice or music impulses, flows through this winding. This flow of current in the primary causes a voltage to be set up between the ends of the secondary, in accordance with the principles of "electromagnetic induction." The voltage developed across the secondary is greater than that across the primary, the approximate ratio of this voltage-amplification being equivalent to the turn-ratio. The flow of current caused by the voltage in the secondary affects the grid element of a vacuum tube (V1—lower right) connected in the secondary circuit; and the tube further increases the strength of the signals by virtue of its own inherent action as an amplifier. (See page 1124, Radio News for April, 1928, for an explanation.) A second transformer (T2) couples the plate circuit of this tube to the grid of another tube (V2—lower left) the double amplifying action being repeated by these devices. The loud speaker, connected in the plate or output circuit of the second tube at the jack (extreme lower left) reproduces the signal impulses as audible sounds.



most popular sizes. The higher the ratio, the greater the increase in the strength of the signals which the transformer affords; but, in most cases, the greater also is the tendency of the instrument to distort the signals. ((Do not let a salesman sell you one transformer in preference to another merely on the basis of its higher turn-ratio; the best transformers usually have fairly low ratings—5 to 1 or lower.)

In selecting transformers for the amplifier to be described in this article, buy the highest-priced ones you can afford; for the tone quality of the receiver is determined largely by them. Good instruments can be purchased for about five dollars apiece (list price); the best ones available to-day sell for an approximate maximum of twice the amount.

### AN A.F. CIRCUIT

The operation of an audio amplifier employing A.F. transformers as the coupling

### BUILDING AN AMPLIFIER

The actual construction of an amplifier that can be added to the "Extension" receiver, to make it work a loud speaker satisfactorily, is a simple job for the man who has already made the set itself. The unit has been designed to go directly behind the set, and will fit with it in the same cabinet, if the latter is eleven inches or more in depth. When the amplifier is put in position it appears to form part of the set's baseboard.

The parts required are few, and are listed, together with their identifying symbols, at the end of this article. The best thing to do first is to give the wooden baseboard a generous coat of shellac or varnish. While waiting for it to dry, cut away the corners of the sheet of copper, as shown in one of the accompanying drawings, and bend up the edges so that a little can 10 inches long, 1½ inches wide and 1 inch deep is formed. Get your soldering iron good and hot, and then seal the seams at the corners. This can is intended to hold the two "C" batteries required for the operation of the amplifier.

Now make a simple L-shaped bracket out of stiff brass or copper, a half inch wide, about two inches high, and with the base of the L about half an inch long. Drill a

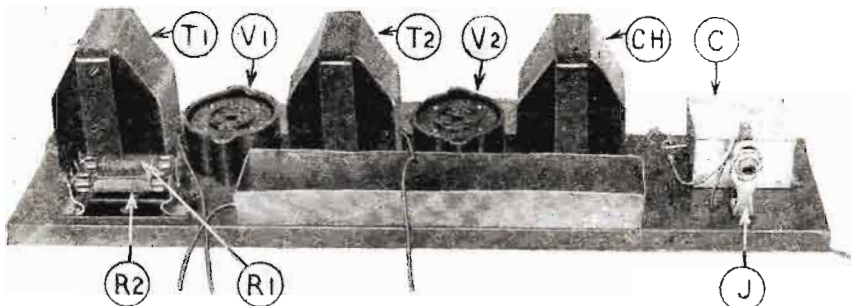

T1 and T2, A.F. transformers; CH and C, output filter; J, phone jack; V1 and V2, tube sockets; R1 and R2, filament ballasts.

\* See page 1319 for details of Free Blueprint Offer.

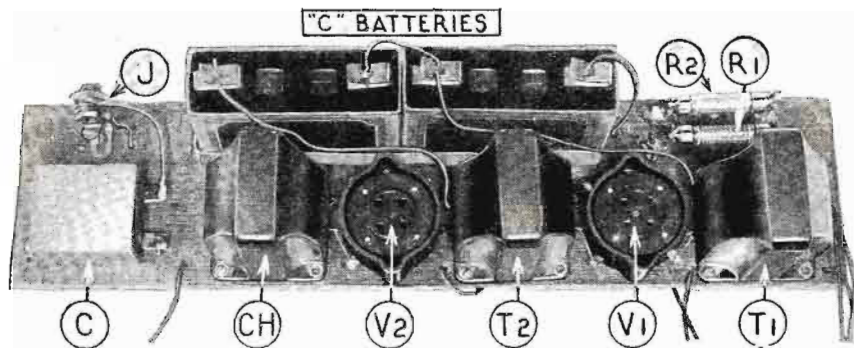

A top view of the A. F. amplifier, in which the "C" batteries are shown in place with the wires connected to their terminals. The other wires go to the batteries and the set proper.

hole through the latter to pass a short wood-screw and through the upper end of the upright piece another hole large enough to pass the mounting shank of the single-circuit telephone jack, J.

The baseboard by this time should be dry; the idea of treating it with shellac or varnish is to prevent it from absorbing moisture and from possible warping. Now arrange the two transformers, the output choke, tube sockets, fixed condenser, filament ballasts and copper can in the positions shown in the various accompanying illustrations and drawings. If you hold the baseboard with the long edge facing you, you will have one transformer, T1, at the extreme left and at the back edge; followed by a tube socket V1; then by the second transformer T2 and the socket V2; and finally by the output choke CH and the fixed condenser C.

Place the transformers with their primary connecting-lugs or posts facing to the left. Arrange the tube sockets so that their "G" and "P" posts are nearest the back edge of the baseboard. With the parts in these positions you will find that all the connecting wires are extremely short and easily installed. Do not screw the instruments down yet; but mark out their outlines and "spot" their screw holes with a hard pencil.

Screw the mountings for the two filament-ballast resistors just in front of the transformer T1. Screw down the little L-shaped bracket in the right-hand corner of the baseboard, and then mount the jack so that its opening faces you.

#### WIRING

You will have to drill through the baseboard only a few holes, for some of the connecting wires. You can determine the exact spots for these holes by studying the pictorial wiring diagrams and noting where the wires disappear through the board. It is possible to keep all the wires on the top surface of the baseboard; but by running a few underneath you will avoid many confusing "cross-overs" and also improve the appearance of the amplifier considerably.

After drilling these holes, you can now screw down the transformers, sockets, choke coil and condenser, and proceed with the wiring. For the latter work, use flexible insulated wire; several good kinds are sold in every radio store. Single, rubber-covered flexible lamp cord is also suitable for the purpose. You may follow either the schematic or the pictorial diagram, as your experience permits. If you use the pictorial diagram, run a pencil through each line in

the drawing as you solder in place the wire it represents. When all the lines have been blacked out, you can be certain you have completed the job.

When you have completed about half of the wiring, nail the copper can for the "C" batteries in the space between the filament-ballast mountings and the telephone jack. Use very short nails with flat heads, or even large tacks, so that the batteries will sit properly in the container.

On the amplifier unit itself, three of the connections, running from the "F" posts of the transformers and from the negative ("A-") lead to the tube filaments, are made of lengths of flexible wire about six inches long. These go to the two "C" batteries. Coming out of the amplifier will be six more flexible wires, which should be cut about a foot long. These are numbered from 1 to 6 in the wiring diagrams, and are handled in this manner:

#### CONNECTIONS TO THE RECEIVER

Wires 1 and 2, soldered to the "P" and "B" posts of transformer T1, connect with

the wires similarly marked P and B in the bunched battery cable which forms part of the two-tube receiver proper. In other words, they lead to the two inner springs of the telephone jack J in the set; so that when you remove the headphone plug, the detector tube is automatically connected to the amplifier.

Wire 3 connects to the side of the switch SW (also in the set) which runs to the filament ballasts R1 and R2 (again those in the set itself). Wire 4 runs to the sides of condenser C3 and resistor R4 in the set, to which the "B+A mp" wire of the battery cable is connected. Wire 5 goes right to either plus post of sockets V1 and V2 in the set, connecting to the "A+" lead. Wire 6 should be extended to form an additional part of the battery cable; it runs to "B+135" volts. (As the original set required only 90 volts of "B" battery, another 45-volt block should be added in series to the present two, and this connection made to the "+" terminal of this battery.)

With the amplifier unit placed against the set in the position shown, these connecting wires will be short and will not affect the operation of the receiver in any way. The amplifier becomes an actual part of the set, as it is now controlled by the one filament switch (SW) on the front panel.

As there is no wiring on the under side of the baseboard of the receiver, and there is some on the amplifier, it will be a good idea to raise the latter above the level of the cabinet bottom by means of four little rubber feet screwed to its under side at the corners. Rubber-headed tacks are also satisfactory. These can be bought in any hardware store.

Two "C" batteries, each of 4½-volt rating, are placed in the copper can. These will last for a long time (as much as a year), as there is no actual drain on them.

#### OPERATION

To obtain actual results from the ampli-

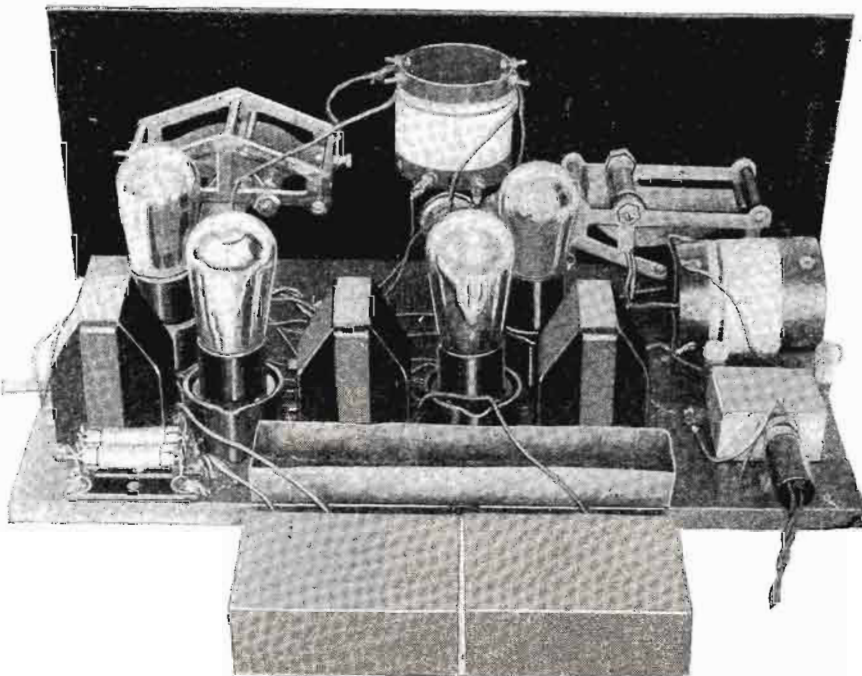

The audio-frequency amplifier connected to the two-tube receiver. The "C" batteries have been removed from their can, so that the transformers and sockets may be viewed.

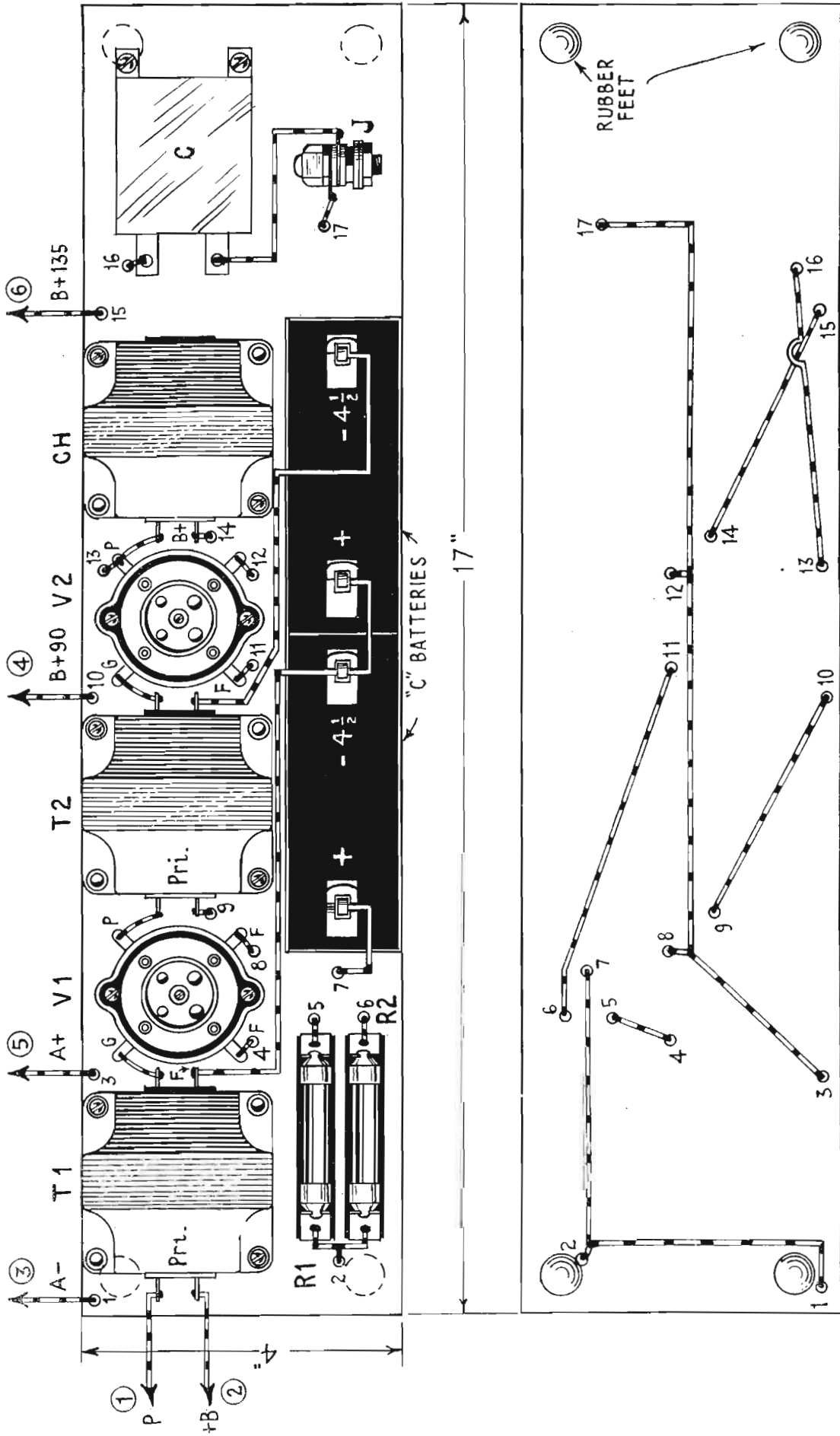

Above is the wiring layout of the two-tube, transformer-coupled audio-frequency amplifier. Where a wire goes beneath the baseboard from above, the hole in the baseboard is numbered. A corresponding number will be found in the lower half of the

diagram, which shows the wiring on the underside of the baseboard. After each connection has been made, run a colored pencil through the connection in the diagram. This will serve as a partial check on your wiring and help to prevent any mistake.

RUBBER FEET



fier after it has been connected in the foregoing manner, insert a 201A-type tube in the socket marked V1, and a 112A in V2. The filament-ballast resistors R1 and R2 should be each of the ¼-ampere size; as the 201A and the 112A tubes each draw this much filament current.

Now simply push the plug, connected to the loud-speaker cord, into the jack J on the amplifier, turn on the filament switch SW and tune the set, as you have already learned through previous experience with it. If it worked all right before, on headphones alone, and produced fairly good signals in the latter, it will now work with the loud speaker without fail. The transformer-coupled type of audio amplifier is practically fool-proof, and will work the first time it is hooked up—providing, of course, it is hooked up properly.

TYPES OF LOUD SPEAKERS

As you probably will buy a loud speaker for the first time either when you begin or after you finish this amplifier, a word of advice about this important instrument will not be out of place. The most generally used type of speaker nowadays is the "cone," which usually takes the form of a large single or double paper "diaphragm" of conical shape, with a driving unit, supported on a suitable stand. Different makes vary in diameter from about 10 inches, for the smallest size, to 36 inches, for the largest; one between 16 and 24 inches is usually best for the average size home. Radio News cannot recommend specific makes of speakers, but the general rules of common sense apply to the purchase of this instrument just as they do to the

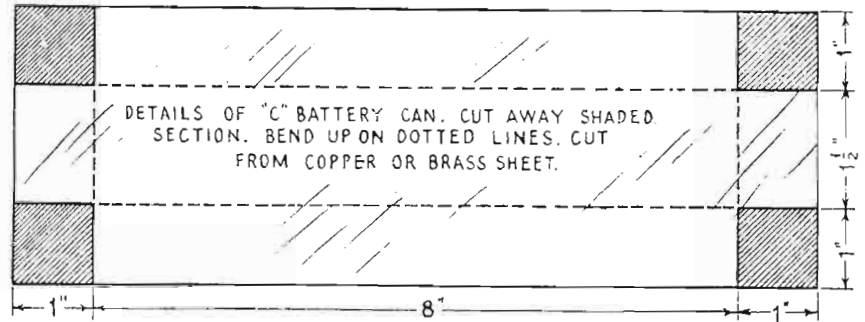

A copper or brass sheet, 10 x 3½ inches, is laid out as shown. The shaded portions are cut out with tin shears and the sides bent along the dotted lines. Solder is run along the intersections to make the can solid.

purchase of any manufactured products. A high-class speaker will average between \$25 and \$35 (list price); there are good ones that cost less, and excellent ones that cost more. Remember that the best set and amplifier in the world will sound "rotten" through a "rotten" loud speaker. If you have sensibly equipped your amplifier with good transformers, assure yourself of complete satisfaction in reception by buying a good loud speaker.

Another type of loud speaker which is enjoying rapidly-growing popularity is the so-called "exponential" horn. This usually takes the form of a large curled-up horn which closely resembles an overgrown pretzel; it opens up into a mouth which may be as large as three feet square. Although many horns advertised as of the "exponential" type are not truly so (see page 1342 of this issue for a discussion of the

advantages of this form of horn), they give good results because of their long tone chambers. In appearance they are rather ugly, unless they are completely enclosed in a cabinet or otherwise concealed. Such horns should not be mounted in the same cabinet with the set, as the vibration of the air in the speaker's tone chamber will cause annoying "microphonic" noises (due to shaking of the tubes).

Some excellent advice on the proper placement of the loud speaker will be found in an article by Charles Magee Adams, also printed in this number. (Page 1310.)

APPARATUS REQUIRED

The list of component parts needed to build this transformer-coupled amplifier is as follows:

(Continued on page 1366)

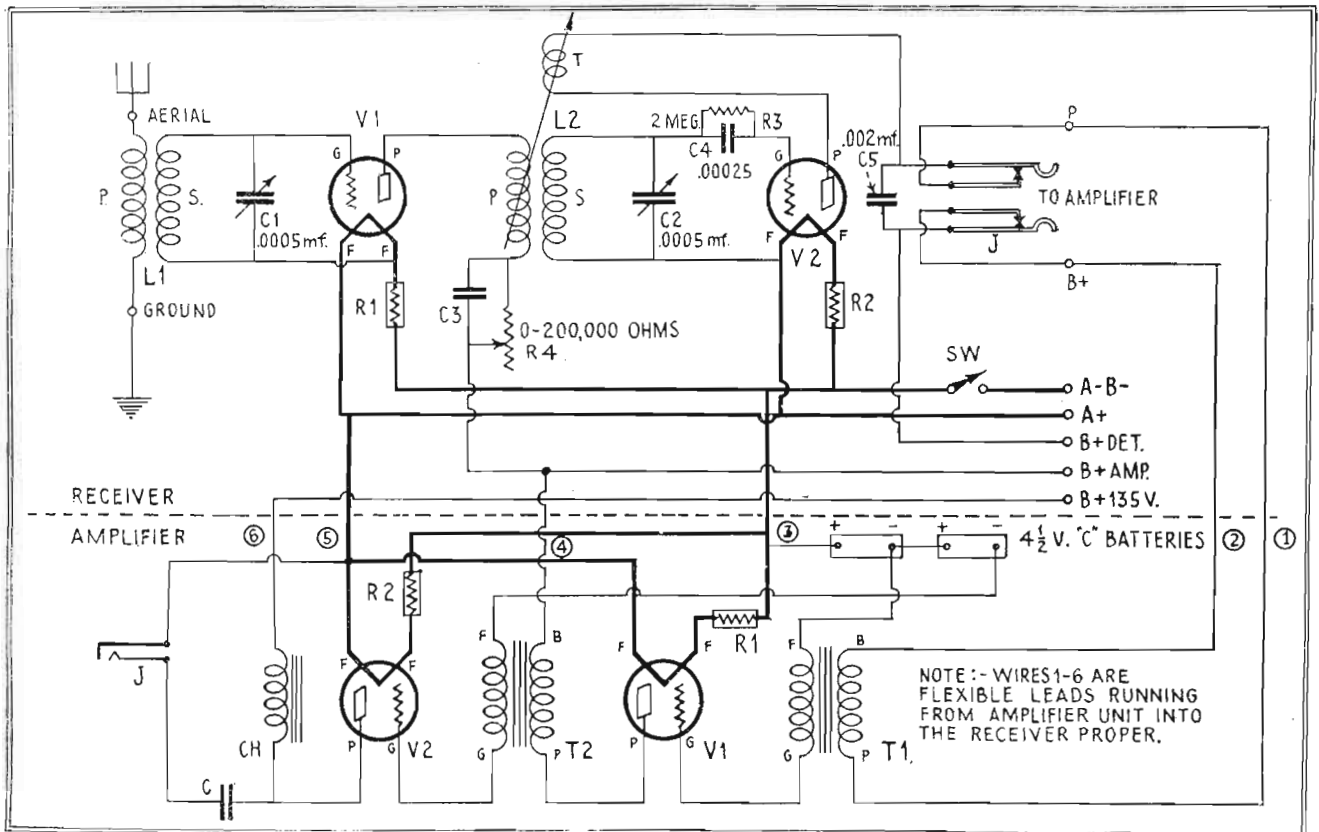

In this schematic circuit diagram the portion above the dotted line is the hook-up of the two-tube receiver published in May Radio News. Beneath this line is

the amplifier circuit described in the present article. Full directions are given on a preceding page for connecting the amplifier to the receiver for operation.

# How To Make The Neutroheterodyne\*



Complete Instructions for Building A Seven-Tube Receiver Possessing Remarkably Good Characteristics



By Herbert J. Reich †

**I**N the construction of the Neutroheterodyne, the most vital parts are the five coils or transformers which are shown in the diagram, from L1 to L5. These are of simple mechanical design and may easily be built with tools found in the average home workshop. Complete details for making them are given in the following paragraphs.

Four different types of coils are used in the receiver. L1 is the oscillator coupler, L2 is the antenna coupler, L3 and L4 are intermediate-frequency transformers, and L5 is the second-detector coil. With the exception of the second-detector coil, all windings of each transformer (coil) are wound on a single bakelite tube having an outside diameter of 2 inches and a thickness of 1/32-inch. The form for the antenna coupler is 4 1/2 inches long; the forms for the other coils are 4 inches long. The second-detector coil differs from the others because of its extra tickler winding, which is wound on a small bakelite tube placed inside the larger form.

The letters used to designate the terminals in the constructional drawings are the same as those used in the wiring diagram. The "G" and "M" terminals are placed 3/16-inch below the tops of the bakelite tubes; all others 7/8-inch above the bottoms of the tubes. The proper location for the lower terminals may be determined by wrapping

a piece of paper around the outside of the tube, marking off the length of the circumference on it, and then dividing this length into eight equal parts. Excellent terminals may be made with 4/36 or 4/40 brass machine screws, 1/2-inch long.

One of the drawings in these pages shows the location of the terminal posts and the spacing of the windings for the antenna coupler or first-detector transformer (L2). The secondary winding consists of 70 turns of No. 26 D.C.C. wire, started 1/2-inch below the upper end of the tubing. The upper end is connected to terminal "G," and the lower end to terminal "R," which is directly under "G." A space of 1/2-inch is left between the bottom of the secondary winding and the top of the primary winding. The latter consists of 40 turns of No. 31 D.S.C. wire, tapped at 10, 20, and 30 turns. The top, or aerial, end of the primary is connected to terminal "A," and the bottom to terminal "40." The taps are connected in order to terminals "10," "20," and "30." The easiest way to take out the taps is to drill holes in the tubing at the proper points and either cut the wire and pull it through, or pull through loops long enough to reach to the terminal posts.

The oscillator coupler is illustrated at L1. The coupling coil of this coupler consists of 15 turns of No. 31 D.S.C. wire,

started 1/2-inch below the top of the tubing. Either of the ends is connected to terminal "O," and the other end to terminal "A." The secondary winding, 55 turns of No. 31 D.S.C. wire, is started 1/4-inch below the bottom of the coupling coil. The upper end is connected to terminal "G," and the lower end to terminal "R," just below "G." The tickler winding consists of 25 turns of No. 31 D.S.C. wire started 1/4-inch below the lower end of the secondary. The lower end goes to terminal "P" and the upper end to terminal "B." It is absolutely essential that the secondary and tickler coils be wound in the same direction and that the ends be connected to the proper posts.

## THE REGENERATIVE COIL

In the construction of the second-detector coil (L5) the secondary, which is started 1/2-inch below the top of the tubing, consists of 70 turns of No. 31 D.C.C. wire. The upper end is connected to "G" and the lower end to "R." The upper end of the neutralizing winding is started 1/8-inch below the secondary, and consists of 41 turns of No. 31 D.S.C. wire. The upper end connects to "B," and the winding is started at the top in such a direction as to carry the wire from "B" away from "N" (clockwise, looking down on the tube). The lower end is connected to terminal "N." This winding should be given a coat of fairly thin collodion and allowed to dry before the primary is wound.

The primary, consisting of 40 turns of No. 31 D.S.C. wire, is wound directly on top of the neutralizing winding, the wire fitting into the grooves made by adjacent turns of the neutralizing winding. The upper end connects to "P" and the lower end to "B."

The tickler winding, consisting of 70 turns of No. 31 D.S.C. wire, is wound in the same direction as the secondary on a 1 1/2-inch (outside diameter) tube mounted within the 2-inch tube. The lower end of this winding should be at the same height as the lower end of the secondary. The lower end is connected to "T" and the upper end to "M." Terminal "M," at the top of the tubing, is also used for mounting the adjustable condenser used to control regeneration. The mounting lug of the condenser is slipped over the terminal post and held by an extra nut. The condenser should be bent back sufficiently so that it can be easily adjusted through the top of the shield. The other end of this regeneration condenser connects to "R." The inside tubing may be readily mounted by means

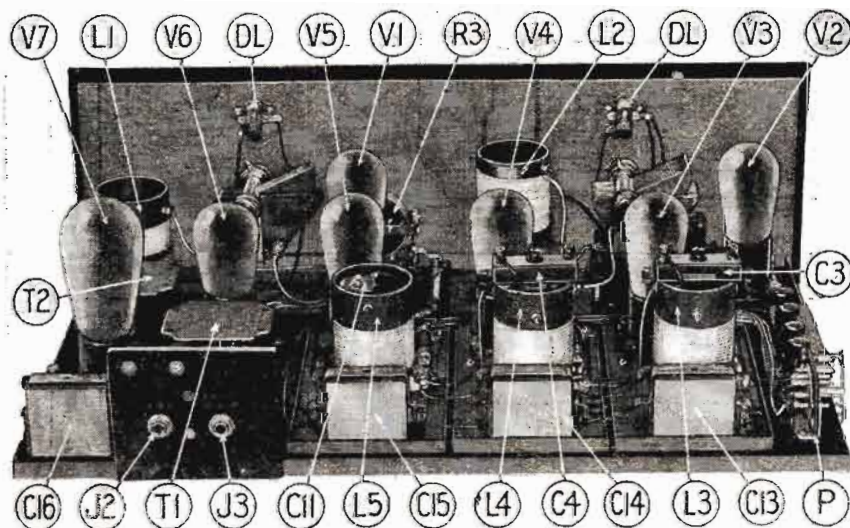

Back view of the completed receiver. C3, C4, adjustable condensers; C11, regeneration condenser; C13, C14, C15, by-pass condensers; C16, output filter condenser; T1, T2, A.F. transformers; J2, J3, phone jacks; DL, dial lights; and P, plug for battery cable.

\* Radio News Blueprint Article No. 56. See page 1319 for free blueprint office.  
† Physics Department, Cornell University.

of the "G" and "M" terminal bolts and spaced by means of washers; and should be just long enough so that the lower end extends about 1/8-inch below the lower end of the tickler. This will leave the heads of the lower terminal posts free for soldering.

The tuning condenser for the second-detector coil, a .0005-mf. mica-type fixed condenser, is mounted by slipping one terminal lug over the "G" terminal bolt of the coil. This bolt should therefore be 1 inch long, instead of 1/2-inch. The other side of the condenser is connected to terminal "R" by means of a short piece of wire or bus-bar.

THE I.F. TRANSFORMERS

The intermediate-frequency transformers L3 and L4 are identical with the second-detector coil, except that the tickler winding and corresponding terminals are omitted, and the "R" terminal is placed on the opposite side of the tubing from "G," instead of directly under it. The neutralizing condensers are mounted by means of the "G" terminal bolts in the same manner in which the regeneration condenser is mounted on the detector transformer. The adjustable tuning condensers are mounted on the tops of the transformers by means of small brass or aluminum brackets; and are connected to "G" and "R" by short lengths of flexible wire or bus-bar, either inside or outside of the tubing. For the sake of

simplicity it is well to wind all coils in the same direction, although this is essential only where it has already been specified.

Collodion, fairly well thinned with a 20% solution of grain alcohol in ether, should be

the windings should be carefully tested for possible breaks or short-circuits by means of a battery and a pair of phones or a voltmeter.

DETAILS OF SHIELDING

It should be pointed out that the constructor of this set will find it impossible to obtain ready-made shields which can be used. Although their construction is not particularly difficult, the average builder will probably find it profitable to have the shields made up by a tinsmith, who has at his disposal all the tools necessary for the work. The seams may be either rolled or soldered. The constructional drawings indicate the design and dimensions of the shielding cans and covers. 16-oz. copper should be used for the intermediate-frequency shields, and 20-oz. copper for the oscillator and first-detector shields, which are open at the panel side, and therefore must be more rigidly made.

The intermediate-frequency cans are made up in three parts: the sides, which are of single sheets of copper with one seam; and the tops and the bottoms, which are identical. The latter are also made of single sheets of copper, cut and bent to form a 3/8-inch flange at the edges. It is best not to solder the flanges at the corners; as it is more convenient to bend them in after the receiver has been completed so that they will fit snugly over the sides of the cans.

The oscillator and detector shields are

**T**HIS seven-tube superheterodyne has the following advantages which will at once attract the constructor:

(1) The intermediate transformers may be readily built at home because of the short wavelength (650 meters) of these stages.

(2) The intermediate frequency selected eliminates the double-reading effect, and makes it possible to obtain selectivity without cutting sidebands and spoiling reproduction.

(3) The receiver is simple, easy of operation and designed for high quality and ample volume.

(4) The complete shielding employed is designed for home construction at trifling cost.

used for fastening all windings. It is readily applied by means of a small camel's-hair brush. The ends of the windings should be soldered directly to the heads of the bolts. After the coils are completed,

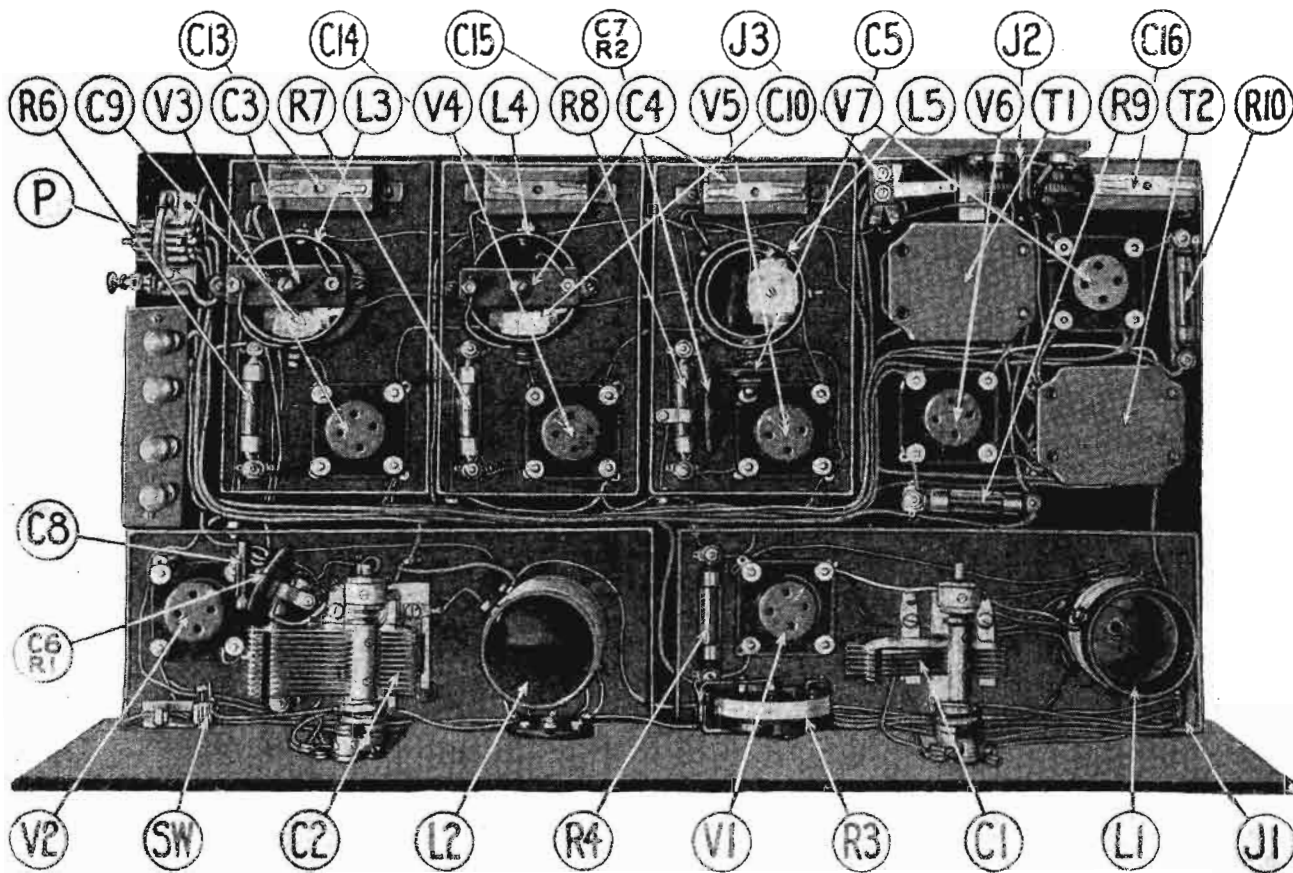

The top view of the Neutroheterodyne, showing the location of the different components. C1, .00014-mf. condenser; C2, .0005-mf. condenser; J1, single-circuit jack; R1, 5-megohm grid leak; R2, 2-megohm grid leak; R3, 20-ohm rheostat; R5 to R9, inclusive, 201A-type filament ballasts; R4, filament ballast,

199- or 201A-type; R10, power-tube filament ballast; SW, battery switch; V1, oscillator socket; V2, first-detector socket; V3, V6, first A.F. amplifier; V7, power amplifier; C8, C9, C10, neutralizing condensers; C5, second-detector tuning condenser; L1 to L5, inductors.

made up in two parts only, the tops being permanently fastened to the sides. The base lids are similar to those of the intermediate-frequency stages, except that there are no flanges on the panel sides. A single sheet of 16-oz. copper, 6 x 21 inches, is used for the panel shield.

LAYOUT AND ASSEMBLY

The layout of the base-board is shown in one of the diagrams in these pages, and no difficulty should be experienced with it if the apparatus is located as indicated. Before the apparatus is mounted, holes should be drilled, or notches cut in the flanges of the base lids and the bottom edges of the cans for the interstage wires to pass through. The exact position of the holes is immaterial, but the wiring will be shortest and most direct if the holes are cut as indicated in the diagram. It will make no difference in the performance of the set whether the wires run through individual holes or are bunched in a single hole. The appearance of the set will be greatly enhanced if the baseboard is given several coats of orange shellac before the apparatus is mounted.

The first step in assembling is to fasten

How the front panel appears. C1 and C2, oscillator and tuning condenser controls; SW1, inductor switch; R3, volume-control rheostat and J1, jack for external volume control.

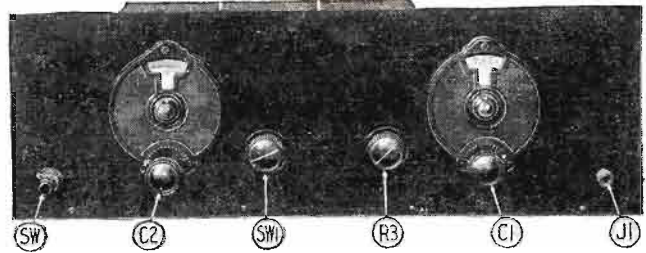

the base shields in position by means of small screws, placed where they will not interfere with the subsequent mounting of apparatus. In mounting the oscillator and detector base shields (S1 and S2) care should be taken to leave sufficient clearance for the panel shield between these and the panel. As soon as the shields have been located, all other apparatus may be located and fastened. An easy way to mount the coils is to fasten a strip of wood inside of each tube, just flush with the bottom, by means of screws through the sides of the tubing. A single screw through the strip will then serve to fasten the transformer to the baseboard.

The diagram shows also the location of

the jacks and binding-posts on the small rear panel. This panel has been so designed and located that the jacks will nicely clear the first audio transformer, and that the plate lead to the first audio transformer will not be materially lengthened by the addition of the phonograph jack. The jack nearest the shield is for the phonograph reproducer, and the other for the speaker plug. The binding posts are also for the speaker connection. If it is so desired, either the binding posts or the speaker jack may be omitted; but it is convenient to have both.

In laying out the panel and panel shield, it is well first to fasten the shield to the panel by three or four small 4-36 or 4-40

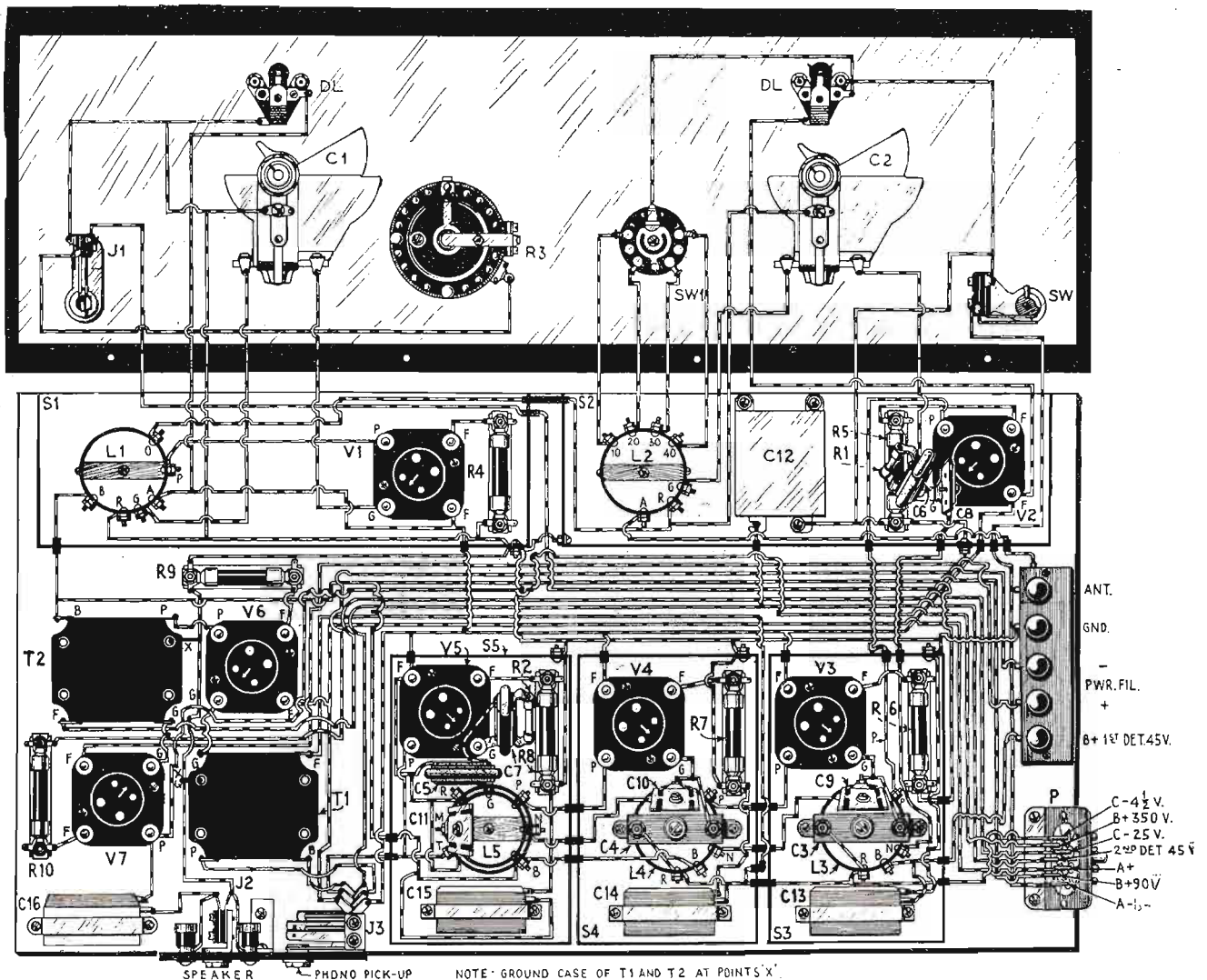

The wiring diagram of the Neutroheterodyne Receiver. As the constructor solders a wire in the set he should run a colored

pencil through the wire in the diagram; thus showing exactly what wires have been put in the set and preventing errors.

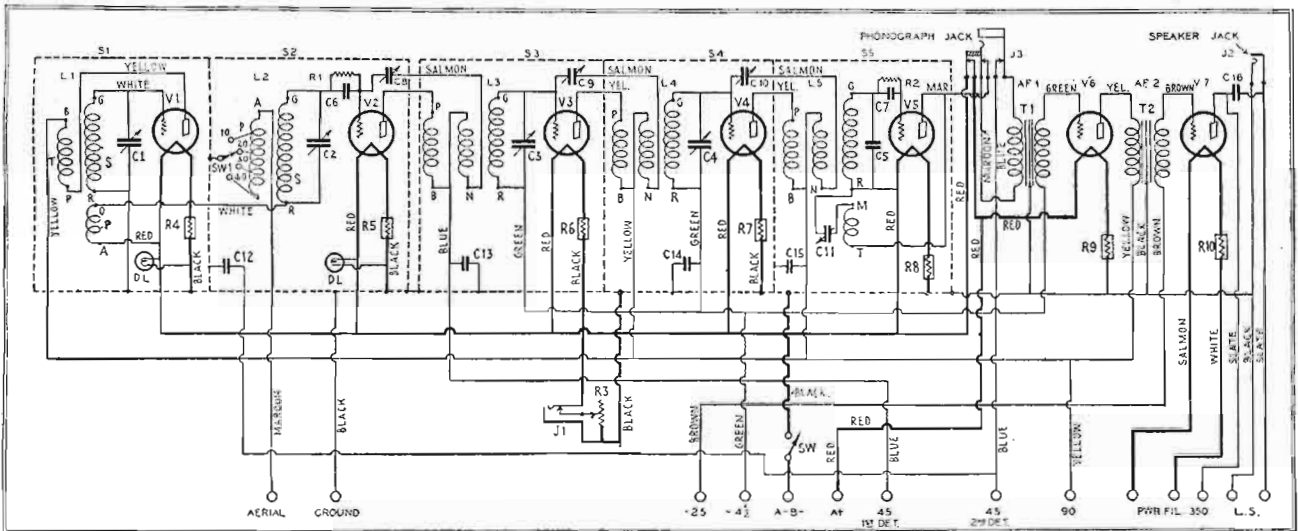

The circuit diagram of the Neutroheterodyne Receiver. Colored insulation for the connecting wires is recommended because of the greater ease and accuracy in wiring it permits. The original color scheme is shown.

machine screws at points which will later be covered up by the tuning dials. In this manner it is possible to drill the holes through both the panel and the copper at the same time, and they will be accurately lined up. The screws may be removed after drilling. Looking at the panel from the front, the left-hand condenser (C2) is that of the first detector, and the right-hand one (C1) that of the oscillator. The left-hand small dial is that of the antenna-coupling switch (SW1) and the right-hand one that of the volume-control rheostat (R3). The battery switch (SW) is at the lower left-hand corner, and the remote-volume-control jack (J1) at the lower right-hand corner.

The first-detector condenser, the antenna switch, and the dial-light sockets must be insulated from the shielding. This may be accomplished for the detector condenser (C2) by making the holes for the mounting screws and nut considerably larger in the copper than in the panel, and mounting a piece of celluloid or thin hard rubber between the condenser and panel. Inasmuch as the detector-condenser shaft is not grounded to the shielding, but connects to the oscillator coupling coil, it is necessary to replace the brass shaft by a piece of 1/4-inch bakelite rod to prevent radiation of oscillator energy when the hand is brought near the dial or touches the metal dial-nut. Body capacity will also produce a noticeable effect upon detector tuning unless this change is made.

Small pieces of celluloid are sufficient insulation for the dial lights (DL) and the antenna switch (SW1). As the arm of the antenna switch is connected to the shielding, the mounting hole through the shield need not be enlarged. The volume rheostat (R3), the oscillator condenser (C1), and the remote volume-control jack (J1) may be clamped directly to the shielding.

It is best to do as much wiring as possible before fastening the panel to the baseboard.

WIRING THE RECEIVER

The use of flexible wire with colored insulation somewhat simplifies the wiring, and, therefore, ten colors have been used.

The color scheme indicated in the wiring diagram and the layout diagram is such as to match up with the color scheme used in the terminal plug. The shielding may be used for all "A—" and ground connections, if so desired; but, as it is difficult to solder to the shielding because of the rapid conduction of heat away from the iron, it is easier and safer to run wires for these leads also. Where necessary, the wires may be connected to the shielding by means of short 4-36 or 4-40 machine screws, head inside, or by cutting a narrow strip out of the flange and bending it down to form a soldering lug.

Eyelets on the ends of the leads wherever they fasten to terminal posts greatly simplify the wiring. Two or three wires may be fastened to a single eyelet, or an eyelet may be attached anywhere along a wire which connects to several different terminals. The writer has found this type of connection fully as safe as the ordinary soldered joint, and it has the advantage of being readily removable for testing or replacement of apparatus. Small lengths of

spaghetti should be slipped over the wires where they pass through the shielding.

After the apparatus on the baseboard has been completely wired, the panel should be put in place. Three or four 3/4-inch No. 4 brass wood screws at intervals along the bottom of the panel will suffice to hold it securely; as the front shielding cans reinforce the panel when they are in place.

OPTIONAL CHANGES

Although the writer built this receiver with the view of operating it in connection with the power pack which will be described in next month's issue, entirely satisfactory results may be obtained when using batteries or any good "B" socket-power unit for supplying the plate potential. However, it should be remembered that two pieces of apparatus, which would normally be connected in the receiver proper, have been mounted in the power unit and, for this reason, if another source of plate supply is employed, these must be connected externally. They are two standard audio

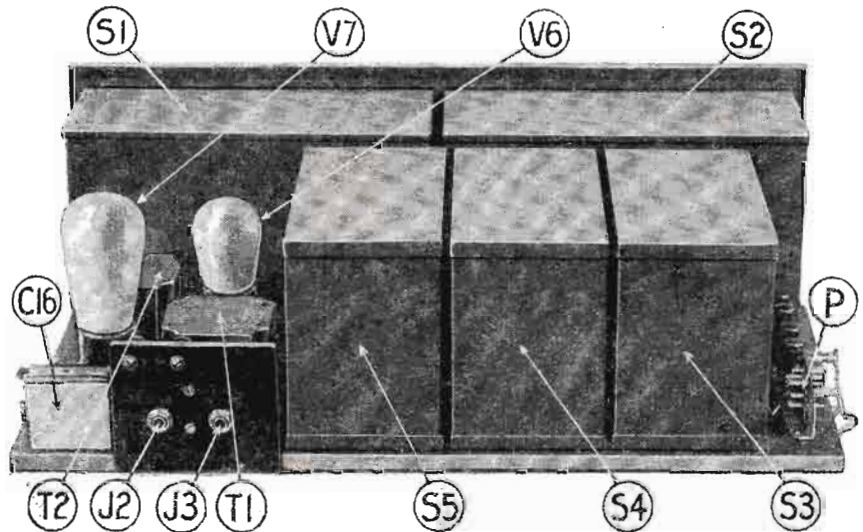

S1 and S2 are the shields for the oscillator and the first-detector stages; S3, S4 and S5 are the shields for the intermediate amplifier stages and the second detector. Details for their construction are given.

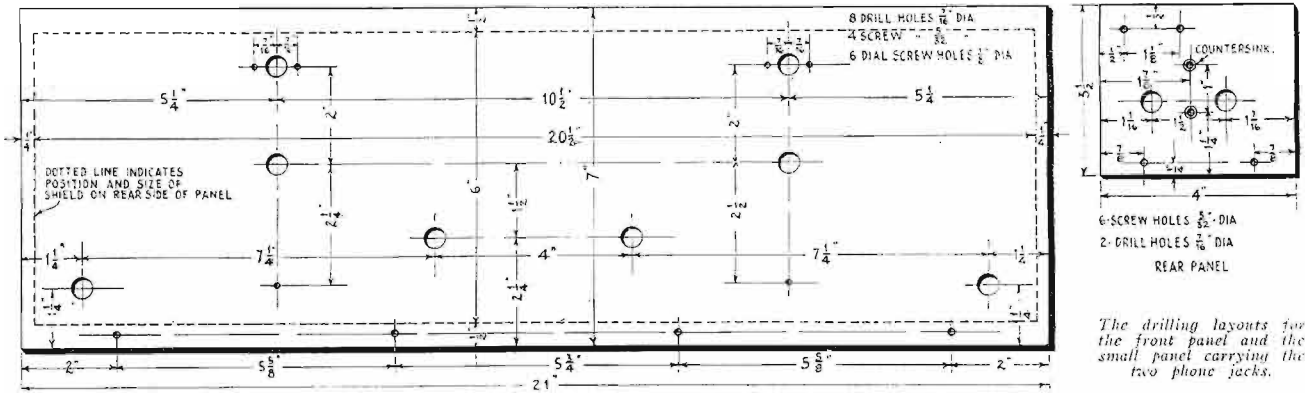

choke coils; one of which is used as an output choke and connected in the plate-supply wire to the power tube; and the other as a detector "B" choke and connected in the plate-supply wire to the first detector tube.

This receiver is intended for operation with 201A-type tubes in all sockets, except that of the last audio stage, which usually employs a 210-type power tube. If desired, a smaller power tube may be used in the last audio stage, and the only change which is necessary to make in the receiver is inserting the proper filament-ballast unit. When the receiver is operated with a 210-type tube, the mounting for the filament-ballast unit may be short-circuited; as this tube should be heated from a 7 1/2-volt winding of a filament-lighting transformer. A 171A power tube may be used with excellent results.

ADJUSTMENT AND OPERATION

When all external connections have been made to the receiver and eliminator, and the "B" and "C" voltages have been ad-

justed to their proper values by means of a high-resistance voltmeter, the receiver is ready for testing and adjustment. A microphonic ring should be heard in the speaker when the second detector tube is tapped. A negative result on this test indicates a wiring error in either the second-detector circuit or one of the audio amplifier-circuits; or else in the main battery leads.

The adjustments in the receiver are very simple and should not take more than about five minutes to make. The regeneration and intermediate-frequency neutralizing condensers (C8, C9, C10 and C11) should be set at maximum capacity, which will tend to make all three stages regenerate. The adjustable condensers (C3 and C4) should then be adjusted until the set oscillates, as indicated by a sharp audio-frequency whistle. The intermediate-frequency amplifier will then be roughly tuned, and the neutralizing-condenser capacities should be cut down until oscillation ceases. If everything has been correctly done, it should now be possible to tune in stations.

Failure of the intermediate-frequency stages to oscillate is an indication that there is an error in the wiring of these. If no signals can be heard after these adjustments have been made, the oscillator and first-detector wiring should be carefully checked. If incoming signals have strong heterodyne whistles superimposed upon the audio frequency, either the intermediate-frequency or the first or second detector stages are oscillating, and the three neutralizing condensers or the regeneration condenser must be readjusted.

As soon as signals can be tuned in, the adjustable condensers (C3 and C4) should be readjusted until signals are received with maximum volume. In making this adjustment the oscillator condenser (C1) should be turned back and forth through the peak to make sure that all three stages are actually tuned alike and there is not a double peak in the intermediate amplifier. The intermediate-frequency neutralizing condensers may be accurately adjusted on signals of any strong broadcast station.

The first intermediate stage is adjusted with the volume-control rheostat turned

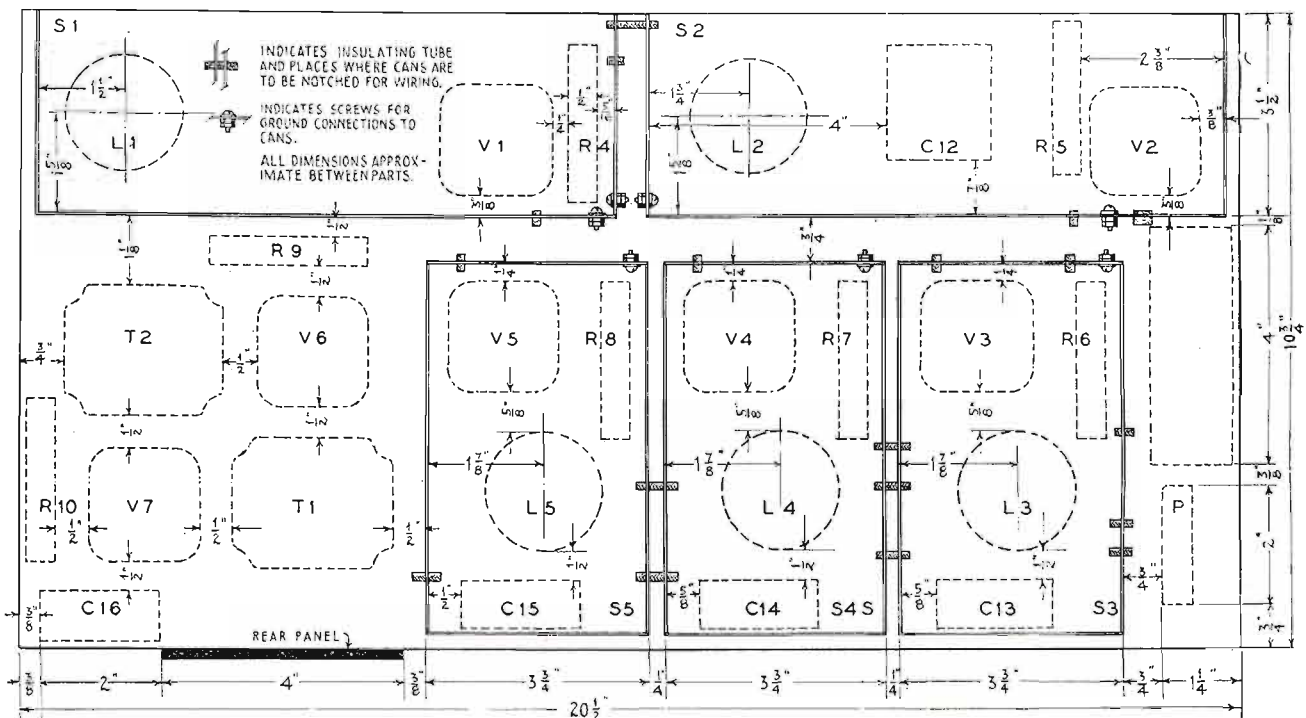

This shows the arrangement of the apparatus and shields on the baseboard. It is recommended that

the constructor follow, as closely as possible, the arrangement shown here and the dimensions indicated.

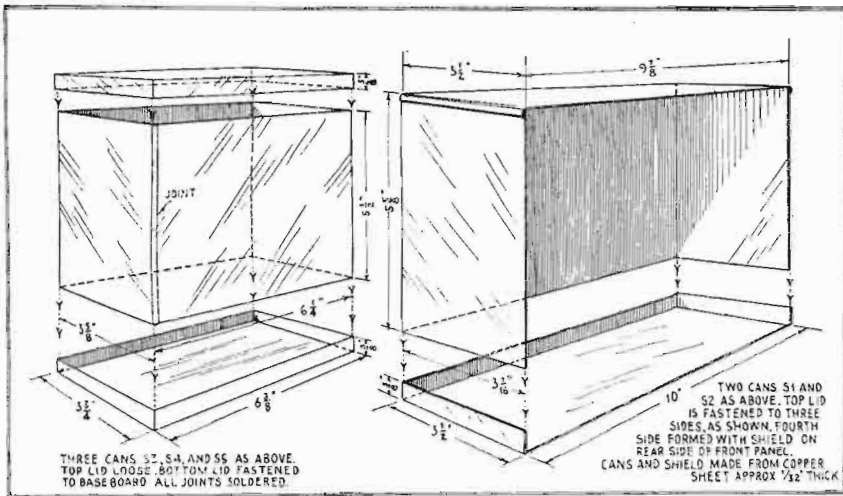

The dimensions are here given for making the five shields; three like the left one being needed, and two like the one on the right.

completely off, so as to turn out the filament of that stage. The neutralizing condenser is then adjusted until no signal can be heard. If any signal can be heard with the volume rheostat turned off it is a sign that neutralization is not perfect. The second intermediate stage is adjusted in a similar manner; but it is necessary either to remove the filament-ballast unit from that stage or to replace the tube with one that has been burned out.

In order to obtain sufficient volume to make possible these neutralization adjustments, it may be necessary to turn on second-detector regeneration fully, possibly even to the point of oscillation. If the detector is made to oscillate then the heterodyne whistle may be used in place of modulated signals in making the adjustments. The first-detector neutralizing condenser should be adjusted until this stage does not oscillate when the tuning condensers are set at or near minimum capacity. Oscillation of the first detector results either in a loud audio-frequency howl or in heterodyne whistles on short-wavelength stations. The second-detector regeneration

control (C11) should be set to give as much volume as possible without any indication of distortion. After these controls have once been correctly adjusted, they need no further attention.

The antenna-coupling switch is primarily for the purpose of adapting the receiver to aeriols of different lengths, and need not be shifted for ordinary tuning. The 30-turn tap will be found best for the average antenna.

PECULIARITIES OF THE SET

It will be found that the two tuning condensers do not run exactly together, and may in fact differ in setting by as much as ten points over part of the tuning range. This results from the fact that the oscillator tuning covers the range approximately included between 1000 and 2000 kc. (as explained in the first part of this article—Fig. 2, page 1244, May Radio News); whereas the first detector must cover the broadcast band, lying between the limits of 450 and 1500 kc. This disadvantage can be completely remedied only by a specially-designed condenser.

Because of the variation of insulation thickness in various makes of wire the tuning condensers may be quite a bit out of synchronism, and may not cover both ends of the broadcast band. For this reason three extra turns have been specified in the design data for the first-detector and oscillator secondaries. Turns should be taken off the top of the first-detector secondary until the detector tunes just up to 550 kc. (WMAK). Turns should then be taken off the top of the oscillator secondary until the two dials read alike at about 700 kc. (about 78 on the dials), which will give the best coordination of dial settings over the whole range. All these tests should, of course, be made with the shields in place.

The oscillator stage has been designed so that it may be used with a 199-type tube in order to reduce the filament current as much as possible. A 201-A type may be used in place of the 199, but nothing will be gained by the change.

Code interference from stations operating on or near the intermediate frequency is readily prevented by the employment of a wave-trap. The wave-trap needed for this purpose is similar to the intermediate-frequency transformers, but has a single primary of 40 turns of No. 31 D.S.C. wire. The secondary and the tuning condenser are identical with those of the intermediate transformers. The primary of the trap should be connected in series with the aerial lead (not necessarily at the set) and the secondary tuned until the interference ceases. The wave-trap will also cut out the small amount of noise or static at intermediate frequency, which may seep through the first detector.

LIST OF PARTS

A complete list of the apparatus employed in the construction of the original model of the Reich Neutroheterodyne follows:

- One variable condenser, .0014-mf. (C1);
- One variable condenser, .0005-mf. (C2);
- Two adjustable condensers, .0003- to .001-mf. (C3 and C4);
- One mica fixed condenser, .0005-mf. (C5);

(Continued on page 1382)

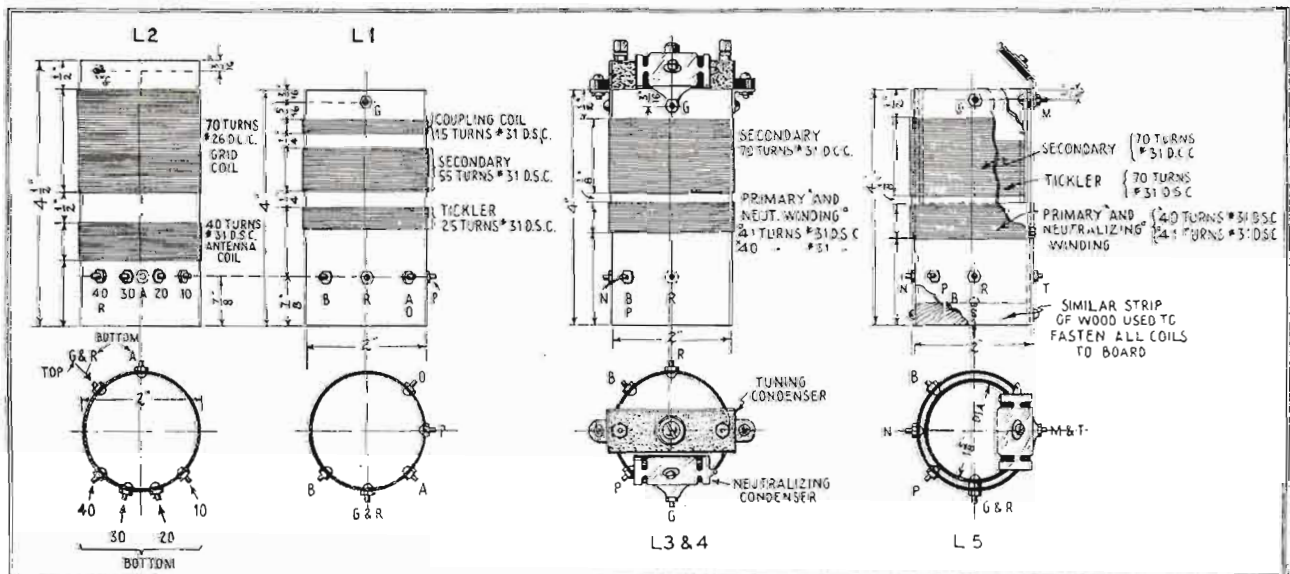

All the data necessary for winding the various inductors of the Neutroheterodyne are given here. The tuning, neu-

tralizing and regeneration condensers are mounted as shown; connections are described on page 1336.

# Developing the Possibilities of a Horn



## Extending the Square Six-Foot Exponential Speaker to Its Optimum Length—Principles of Its Design



By Chester Schenck

**A** PRACTICAL article entitled "An Exponential Horn of Square Cross Section," by T. H. Millar, Jr., appeared in the October, 1927, issue of *RADIO NEWS* (page 347); and since that time a great many sheets of heaverboard have, no doubt, been patiently cut, nailed, glued, and taped to shape, producing inexpensive but efficient horns for their constructors.

Another issue of this magazine, for August, 1927, contained an article "A Loud Speaker With a Three-Quarter-Mile Range," by Clinton R. Hanna, which embodied considerable information pertaining to the design of exponential horns, a subject on which Mr. Hanna is a recognized authority.

Now, assuming that we have made and are enjoying one of the six-foot horns described in the first article, and that we are looking for something else to try out, let us examine the design of our horn in the light of the article last mentioned; partly for the information to be obtained and partly for any improvements that may suggest themselves to us.

### THE HORN'S LOWEST NOTE

It is found that an exponential horn is one whose area of cross section doubles, triples, or multiplies at some other definite rate, for each foot of length; this multiplying number or factor is known as the rate of expansion, and is an important factor in horn design. Our horn is  $\frac{5}{8}$ -inch square at the small end; its area is multiplied by some definite number to obtain the area one foot further down; again by the same number to obtain the area at two

feet from the small end; and so on until, after the tenth multiplication, the mouth is 20 inches square.

To cut a long calculation short, we will find by the use of suitable tables that the rate of expansion in the case of our six-foot horn is 3.175. That is to say, whatever the area of one cross-section of the horn at any point, one foot further along its length we will find the area of the next cross-section to be 3.175 as great. This was the principle followed out in designing the horn. (Its dimensions, given very minutely, are reprinted here for the benefit of readers who have not a copy of the original article, which is now out of print. In addition, for the benefit of our readers who have not at hand the "logarithmic tables" used by the designers of horns, figures are added at the end of this article whereby any reader can work out his own by simple arithmetic.—EDITOR.)

Mr. Hanna pointed out that the rate of expansion determines the lowest, or cut-off, frequency, down to which the horn is a uniform radiator of tones; and that this frequency is 64 cycles for a horn which doubles its area for every foot, 32 cycles for one increasing half as fast, and 128 cycles for one which multiplies in area four times per foot. It will be convenient to determine the cut-off frequency of our horn by plotting a curve, Fig. 1, on which rates of increase are plotted as vertical distances ("ordinates"), and cut-off frequencies in cycles per second as horizontal distances ("abscissas"). The three cut-off frequencies given are used to locate the curve; then a horizontal line is drawn at

the height or ordinate 3.175, until it intersects the curve. Dropping a perpendicular from this point to the axis determines the



The extension of the exponential horn is the part above the white band near the top; its construction is described here.

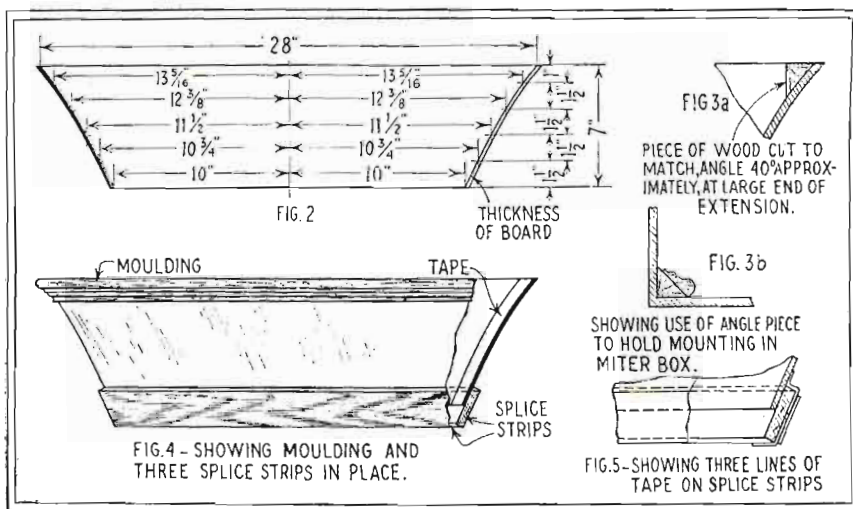

Figs. 2 to 5, in the drawing above, give the necessary details for the construction of the extension of the exponential horn. The data for the horn itself are repeated in Fig. 6a on the opposite page, because the original article is out of print.

cut-off frequency to be about 106 cycles per second.

It was also stated that, if the diameter of the mouth of the horn is made comparable to one-quarter of the wavelength corresponding to the cut-off frequency, the undesirable resonance of the horn will be very small. Dividing 1120 (the velocity of sound in air in feet per second) by 106 (the cut-off frequency) gives 10.56 feet, the length of a single wave at cut-off frequency, or 126.7 inches. One-quarter of 126.7 inches is 31.7 inches, which would be the correct diameter of the mouth of the horn if it were circular. The area of a circle of diameter 31.7 inches is 789 square inches, and the side of the square having the same area is just about 28 inches.

### LENGTHENING THE HORN

Our horn should, therefore, have been extended until it was 28 inches square, instead of 20 inches, to fulfil these conditions. Possibly that would have made the horn so long as to be unwieldy; suppose we find out. A brief calculation will show us that the greatest effective length of the



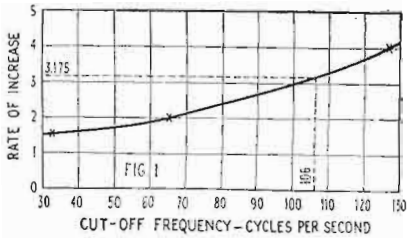

How the cut-off frequency of an exponential horn varies as the rate of expansion is increased.

horn, when its bell is 28 inches square, will be 6.5825 feet, or 6 feet 7 inches approximately. We conclude then that, by adding 7 inches to the length and increasing the size at the large end to 28 inches square, the horn should, theoretically at least, show some improvement over its original performance, even though it can not reduce the lower limit of frequency.

After making and using such an extension, the writer believes that considerable betterment of the ability of the horn to handle the various sound-variations smoothly can be detected. In addition, one has the satisfaction of knowing that the horn is more nearly in accord with the theory of design. Some of the improvement may be due to stiffening the sides of the horn and forcing it to take its proper square cross section.

In order that others may make the experiment for themselves, detailed directions are here given. Anyone who has the required space near his radio set may build and install the extension with a minimum of effort. (Before beginning, however, it is well to measure the width of any doors through which the horn may have to be taken, as there may not be sufficient room to pass the whole assembly.)

WHAT IS A 106-CYCLE NOTE?

At this point suppose we determine just what the cut-off frequency of 106 cycles gains for us in the way of low-note reproduction. On page 483 of the November 1927 issue of Radio News is printed a chart, showing the frequency-ranges of various musical instruments and the human voice, as well as the ranges of some radio sets and the orthophonic horn. It will be seen that the lowest note to be efficiently handled by the horn is the "A" on the lowest space of the bass clef, which is also the lower limit of the French horn, and practically the limit of the "orthophonic" 72-inch. (Quite appreciable portions of the ranges of various low-toned instruments are below the 106-cycle limit, but a much longer horn with a different rate of expansion would, of course, be required to handle these low notes perfectly—and, also, they are not entirely suppressed, even by a shorter horn.)

Proceeding with the constructional data: Fig. 2 shows the dimensions of the four pieces of beaverboard which are to be cut to form the extension. A thin strip of wood, used as a flexible rule and sprung so that it may be held with one edge passing through the points while another person marks along the curved edge with a pencil, makes a convenient device for drawing the end curves on the pattern. If the constructor has saved the remnants of his original sheet of beaverboard, there will probably be enough for these pieces.

It is a somewhat tedious task to cut the beaverboard; but a medium-toothed hacksaw blade has been found to do good work, with comparatively little effort. After the four pieces have been cut they may be joined as in the original horn, using fine 3/4-inch brads and 1/4-inch gummed tape, cut in 3-inch lengths to follow the curve.

MOUNTING THE NEW BELL

For appearance's sake, a fairly heavy moulding may be cut and nailed around the large end of the extension, as the next step in construction. This is somewhat difficult



This horn is of a type recently popular. Its "cut-off frequency" is very high, because of its shortness; yet music gets through, even though it does not go so far as if the horn were longer.

to cut so that neat joints are made; and it may be omitted if desired. However, it will be more bothersome to add it later. By beveling a piece of wood to match the angle of the edge of the assembled extension, approximately 45 degrees, and using it to support the moulding as it is being sawed in the miter-box (as shown in Figs. 3a and 3b) a good job may be done. The miter-box is set to saw at 45 and 135 degrees just as ordinarily required.

For splicing the extension to the horn, four pieces of a soft wood which will not split easily (sugar pine being one such wood) about 5/16- or 3/8-inch thick by 2 inches wide, are prepared. A line is marked, lengthwise, down the exact center of one side of each of three of the pieces. Then two of these pieces are nailed on the outside, and on opposite faces, of the smaller end of the extension; using the line on each piece as a guide in order to leave exactly half of the wood projecting beyond the edge of the beaverboard.

Glue should be used between the wood and beaverboard; and "flat-head" wire nails, 1/2- or 3/4-inch long should be driven from the inside through the beaverboard and wood and clinched smoothly on the outside. A heavy hammer, held against the heads of the nails, will prevent their "backing up" while the clinching is being done. Both ends of the pieces are next cut off flush with the outside surface of the beaverboard; following the curve slightly, yet keeping the cut as straight as possible. This also can be done with the hacksaw blade. The third marked piece is then nailed across

one of the remaining sides, using the line as a guide as before, and sawing its ends off flush with the outside surface of the first boards placed. The complete extension at this stage of construction is shown by Fig. 4.

Next the horn proper is laid on a table or bench with its large end projecting over slightly, and something soft should be placed under it to avoid injuring the sides of the horn while the splice is being finished. The extension is carefully slipped over the end of the horn from below, using the open side as a gateway. The sides of the horn, as originally constructed, will be considerably bowed inwardly and must be straightened while being nailed. Begin on the last wooden strip placed, and be sure the beaverboard on that side is flattened and centered carefully before starting to nail. Glue should be used freely, and the splice nailed both ways from the center of the one side, putting on the fourth wooden strip last and thus completing the joint.

To cover the ends of the clinched nails, which otherwise present an unsightly appearance, 1/4-inch gummed tape may be used all over the wooden strips, as shown in Fig. 5, three pieces being required to cover each satisfactorily. Another strip of tape should be used to cover the line of the splice on the inside of the horn. One coat of white shellac on the inside, and two on the outside, make a satisfactory finish. The horn, with its extension as completed is shown in the picture on page 1342.

(Continued on page 1377)

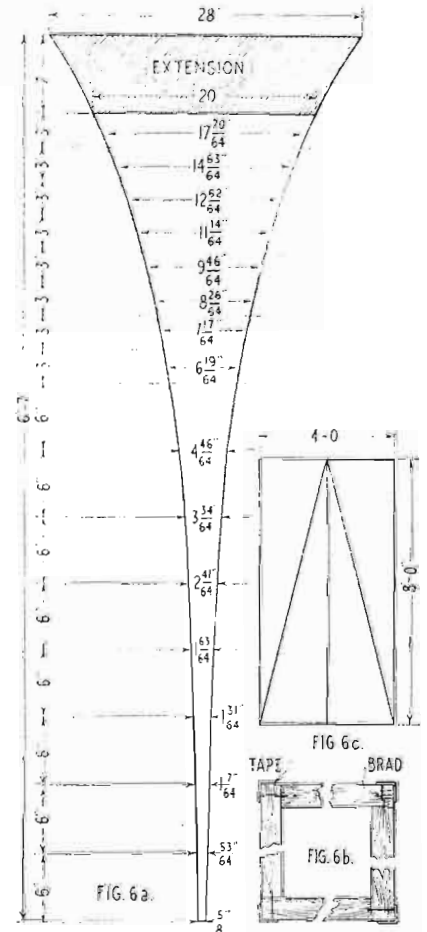

The dimensions of the square 6-foot exponential horn are repeated here, with the 7-inch extension indicated. The sides are cut from a sheet of wall board (Fig. 6c) and fastened together as shown in Fig. 6b.

# The How and Why of Radio Filters

by **Fred H. Canfield**  
*Technical Editor*

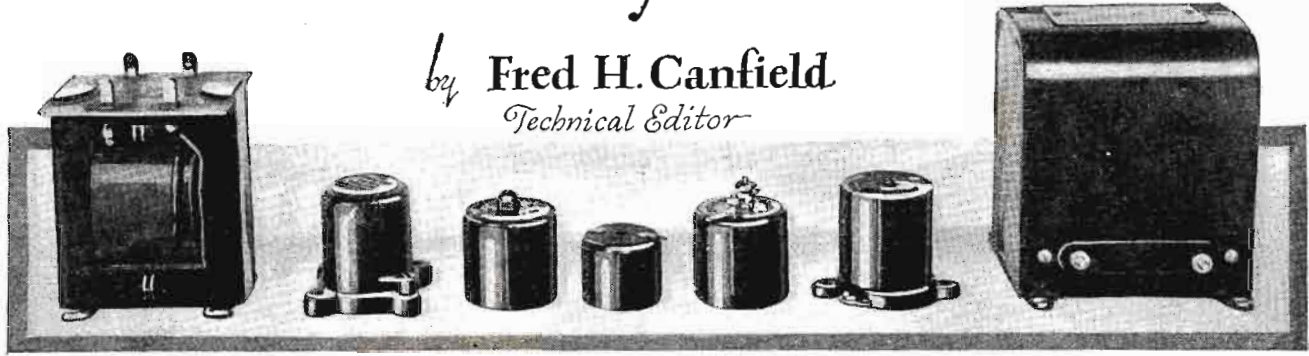

The two large cases contain chokes for use in audio-frequency filters, and the five small ones radio-frequency chokes.

**M**ANY set builders are of the opinion that radio engineers insert choke coils and by-pass condensers in their circuit designs for radio receivers either for their own amusement or for the sole purpose of causing the public to purchase additional equipment when building sets. Among radio constructors, there has circulated the rumor that these instruments may be removed from most circuits without affecting the operation of the receivers in any way, and some experimenters have proved this "fact," to their own satisfaction, at least. However, when poor results are experienced with such a set, most fans think they have selected a poor circuit; and it seldom occurs to them that the trouble might be corrected to some extent, at least, by the use of choke coils and condensers.

Because of the general misunderstanding which seems to exist on the subject of choke coils and by-pass condensers, the writer will endeavor to show the purpose of these instruments in electrical circuits, and, at the same time, to explain how they may be used most intelligently in radio receivers. It is, of course, ridiculous to assume that engineers specify apparatus which is not necessary in receiver designs. Therefore,

the set builder who considers a part unnecessary should attempt to find the reason why it is used before eliminating it from the receiver. If this plan were followed by everyone, the average home-built receiver would give much better performance.

A choke coil may be described as a device

which hinders alternating currents of a certain frequency or frequencies from passing and, at the same time, readily allows direct current and alternating current of lower frequencies to pass; it consists of a number of turns of wire. Choke coils for use in radio-frequency circuits are usually of the air-core type, while audio-frequency choke coils almost always have iron cores.

radio-frequency currents to pass through them. In radio circuits, choke coils and by-pass condensers are commonly used together; i.e., the choke coil is employed to prevent currents of a certain frequency from entering a circuit and the by-pass condenser is used to provide a new path for the excluded current. In this way it is possible to separate the alternating- and direct-current components which are present at the same time in one circuit; and it is possible also to separate the radio-frequency and audio-frequency components by the same method. That portion of a circuit which consists of a choke coil and by-pass condenser is known as a "filter."

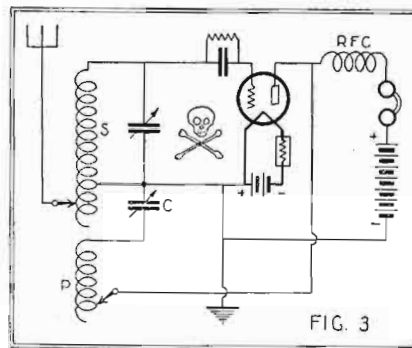

In order to return as much as possible of R.F. energy to coil P for regeneration, the choke RFC is inserted, keeping this current from the phones and battery.

### A DOUBLE-FILTER SYSTEM

A hypothetical diagram (Fig. 1) gives an example of how currents of different frequencies may be separated by means of choke coils and by-pass condensers in combination (filters). In the complete circuit (A), of this illustration, L1 is a transformer with a primary winding P and a secondary winding S; B is a battery; RFC a radio-frequency choke coil; AFC an audio-frequency choke coil; and C1 and C2 are by-pass condensers, small and large respectively. In this circuit a current composed of two different frequencies is induced in the secondary winding of the transformer by the primary winding which, we will say,

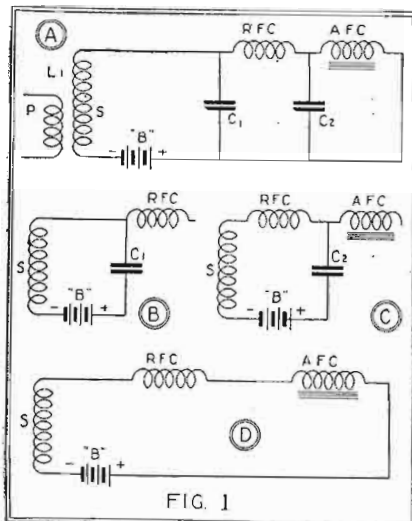

A is the complete circuit; B the path taken by the R.F. current; C, path of the A.F. current, and D that followed by the battery's direct current.

### "BY-PASSING" ACTION OF CONDENSERS

By-pass condensers perform an exactly opposite function in a radio receiver. These may be described as fixed condensers of standard type, which are connected in a circuit in such a way that currents of one frequency or band of frequencies are forced to pass through them; but D.C., and A.C. of lower frequencies are practically unable to pass. The capacity of the by-pass condenser determines the frequency of the current which it will pass efficiently. For example, a small condenser (say .001 mf.) will by-pass only high- or radio-frequency currents; while a large condenser (1.0 mf.) is needed for audio-frequency circuits. However, large by-pass condensers will allow high- (radio-) frequency as well as au-

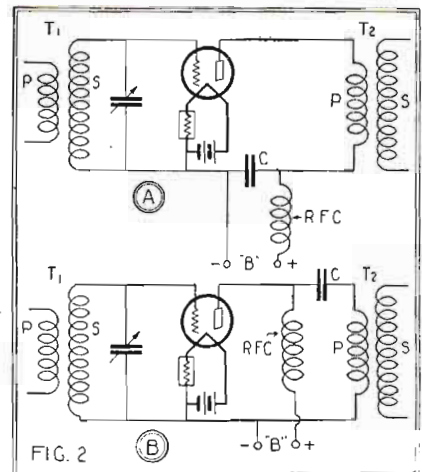

Two methods of using R.F. chokes and condensers in the plate circuit of a receiver, for the prevention of interstage coupling.

is connected to an audio-radio-frequency oscillator. Also, the battery B introduces direct current into the circuit.

The problem is to separate the three different components of the current. This is accomplished by the action of the choke coils and the by-pass condensers. A glance at the diagram will show that the R.F. component of the current cannot pass the R.F. choke coil (RFC) and, therefore, is forced to go through the by-pass condenser C1. However, direct current cannot pass through a condenser and the capacity of C1 is so small that very little A.F. current is able to follow this path. Therefore, the direct-current and the A.F.-current components continue through the circuit until the A.F. component is impeded by the A.F. choke coil (AFC). This current is then forced to pass through the by-pass condenser C2. As the direct current is not stopped by

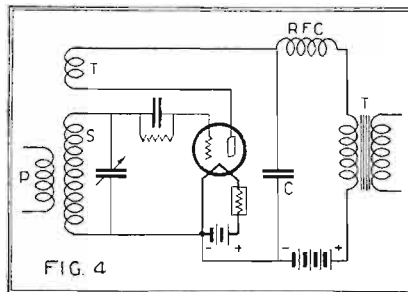

The choke coil RFC and condenser C are connected as shown, in order to keep R.F. currents out of the A.F. amplifier, where they would tend to overload the tubes.

tuned circuits its existence causes poor results; whereas, in other parts of the set, it is needed to produce a voltage drop for biasing purposes, to reduce filament current, etc.

Coupling is a consideration equally as important as regeneration and resistance. It is essential to the operation of every receiver that the various circuits be coupled together; however, the way in which this is done is often responsible for either the success or failure of the set. In certain parts of the circuit the coupling must be highly efficient, while in others any trace of coupling causes poor or undesirable results. This applies not only to radio-frequency circuits, but also to audio-frequency and power circuits. In many cases undesired coupling may be prevented by a system of choke coils and condensers.

CONTROL OF REGENERATION

In order to explain one of the most frequent causes of undesired coupling, and its effect upon the operation of a radio receiver, the writer will refer again to his article, "Regeneration—What it is and What it Does," which appeared on page 1234 of last month's Radio News. In this article it is explained that regeneration is caused by coupling between the plate and grid circuits of a vacuum tube; as such coupling makes it possible for plate-circuit energy to be returned to the grid circuit and to be re-amplified excessively. This coupling may

be effected by the use of either condensers, inductors or resistors; but in all cases the effects upon the receiver are similar.

A limited amount of regeneration in a receiver is beneficial; for it tends to reduce the "effective resistance" of the circuit, and also improves the selectivity and sensitivity of the receiver. However, if the regeneration is not properly controlled, the results are unsatisfactory. Where too much regeneration is present, the set is unstable in operation and is apt to enter a state of sustained oscillation, on the least provocation. This ruins the utility of a set for the reception of broadcast programs; as speech or music becomes badly distorted.

In designing receivers, engineers have provided many ways for controlling and limiting regeneration. In some systems, energy is fed from the plate circuit to the grid circuit with the phase of the current

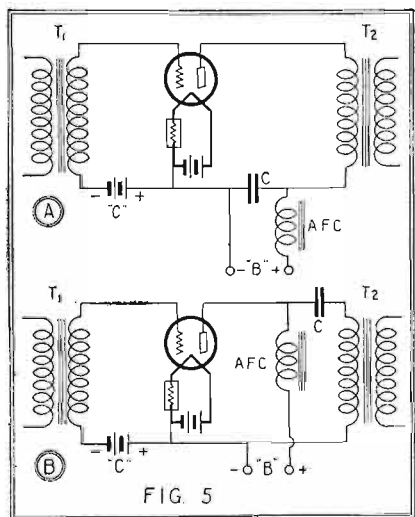

Two methods of using A.F. choke coils and condensers. A is the more usual, and B one used when the plate-supply current is heavy, to keep the plate current from the transformer's primary.

the choke coils, it passes through the coils and makes its return to the battery via the only available path.

The circuit action is further analyzed in detail at B, C and D (Fig. 1), which show more clearly how the three different currents were separated. B is the path of the R.F. current, which is unable to pass the R.F. choke coil; C is the path of the A.F. current, which is unable to pass the A.F. choke coil; and D is the path of the direct current, which is unable to pass through the by-pass condensers C1 and C2.

USE OF R.F. CHOKES

Now that the purpose of by-pass condensers has been explained, we are ready to consider the various ways in which choke coils of various sizes may be used to advantage with them in radio circuits. As R.F. and A.F. choke coils are used in different parts of the circuit, the use of the R.F. choke and by-pass will be explained first.

In last month's issue of Radio News, it was pointed out that regeneration, when correctly used, is a great aid in increasing the sensitivity and selectivity of receivers. On the other hand, in circuits where regeneration is not required, and where it cannot be controlled properly, its presence is sufficient to ruin reception. The same is true of resistance in a radio receiver; in

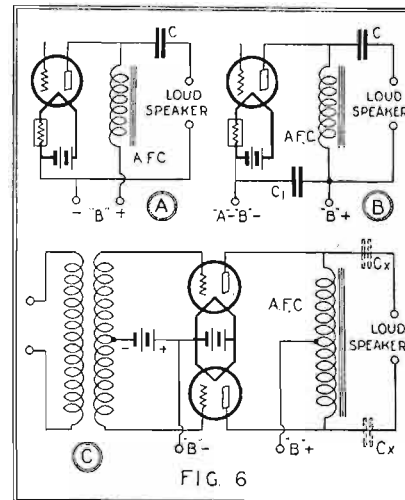

Chokes and condensers also keep plate supply from the loud speaker's windings, as shown above. A and B show an ordinary amplifier and C is for a push-pull system.

reversed, so that it neutralizes any normal feed-back current which may exist. In other systems, resistors are connected in the grid circuit of each tube to overcome regeneration, or other means are employed to reduce

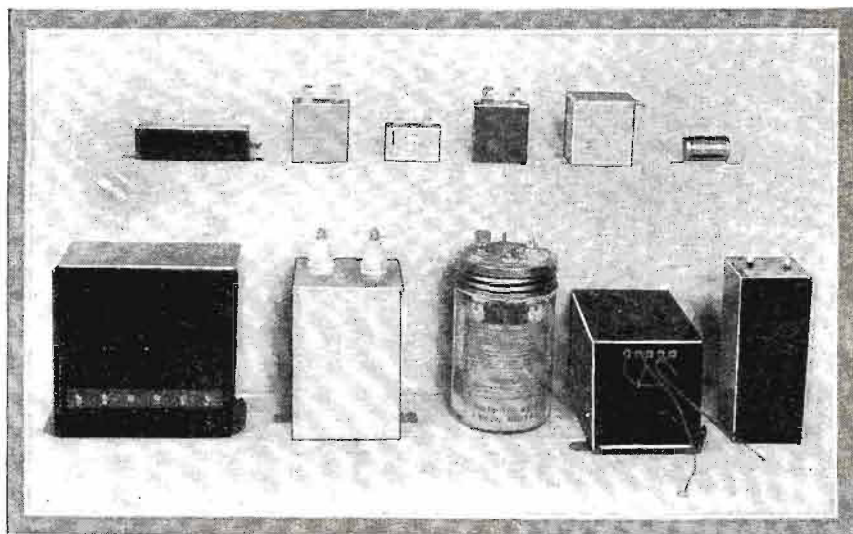

Above are two groups of condensers of high capacity. Those in the upper row are suitable for use as A.F. by-passes. Those in the lower row are of types suitable for power filters.

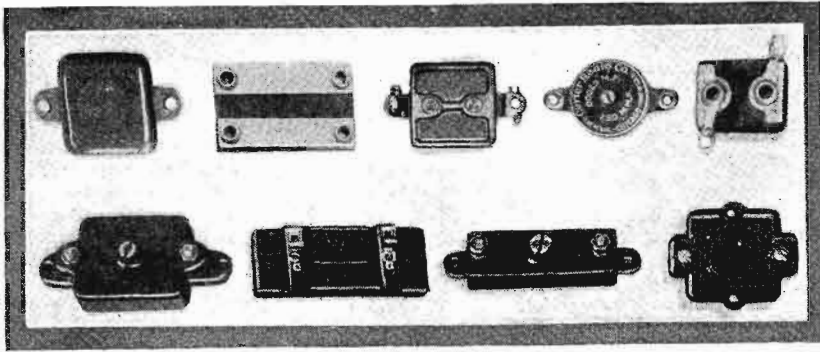

the usual method; with the choke coil RFC connected in series with the "B+" supply wire to the primary of the R.F. transformer; and the by-pass condenser C connected between the filament circuit and the "B+" side of the R.F. transformer primary. Diagram B shows the use of the choke coil in a shunt-feed circuit; by this arrangement the "B" power is delivered directly to the plate of the tube through the choke coil and the R.F. energy is transferred from the plate to the following transformer primary through the by-pass condenser. Both circuits give approximately the same results and, in each case, the choke coil prevents the R.F. current from entering the

the efficiency of the circuit. Shielding, automatic coupling-variation and grid-bias control are still other processes which are employed for limiting regeneration.

A fact which puzzles many experimenters is that a radio receiver may perform excellently in one location, but give very poor results when it is connected to other batteries or a socket-power unit in another location. Some persons are inclined to blame the new location for the trouble but, in a majority of cases, it will be found that the new batteries or the power unit are responsible. An examination of the circuits of most receivers will show that the same

In the above illustration are shown various types of fixed condensers which may be used in filter circuits as R.F. by-passes. In Fig. 7, at the right, the coils marked L and L1 are audio-frequency choke coils, which are employed instead of transformers in an impedance-capacity-coupled audio-frequency amplifier. The condenser C transfers the energy from the plate of one tube to the grid of the following one; the chokes being in the circuit to retain the A.F. impulses, yet supply the needed voltages to the grids and plates.

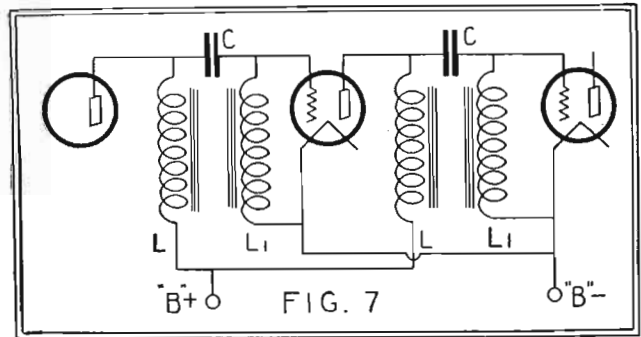

tion and sometimes strong oscillation is produced.

**CHOKES IN THE PLATE LEADS**

One of the most important uses of R.F. choke coils is to prevent interstage coupling which might take place through the "B" power-supply device. These choke coils not only tend to make the operation of the receiver more stable by preventing feed-back, but they often improve the selectivity of the set by preventing the long "B" supply wires from acting in the capacity of aerials. When the "B" batteries are new the advantage of the choke coils may not be very apparent; but, where socket-power units or old batteries are used for the "B" supply, the judicious use of choke coils and by-pass condensers will often greatly improve results.

Fig. 2 shows how the coils and condensers should be connected with the "B" supply wires of an R.F. stage. Diagram A shows

"B" supply wires; while the by-pass condenser provides a path for the R.F. signal to go directly from the plate of the tube, through the transformer and thus reach the filament of the next tube.

In this illustration, the choke coil and condenser are used to prevent coupling. However, there are other circuits which require choke coils to create coupling. An excellent example of this is in the Reinartz circuit, shown in Fig. 3. In this circuit, in order to obtain regeneration, it is necessary that the R.F. energy in the plate circuit of the detector should be fed back to the grid circuit through the plate coil P of the coupler and the regeneration condenser C; therefore, the purpose of the choke coil RFC is to prevent the energy from going through the headphones and "B" battery. In this case the by-pass condenser (C) is variable, as it is used to control the amount of feed-back.

(Continued on page 1366)

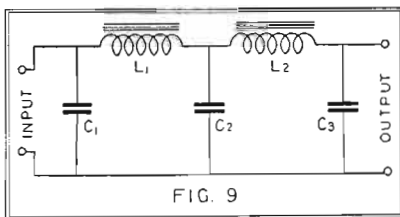

How chokes and condensers are used in a power-supply unit to smooth out the "ripples" in the rectified current.

source of power is used to provide potential to the plates of all the tubes. As there is a certain amount of resistance in the batteries or power unit, the various circuits of the set are linked together by a form of resistance coupling; and, as a result, feed-back takes place and regenera-

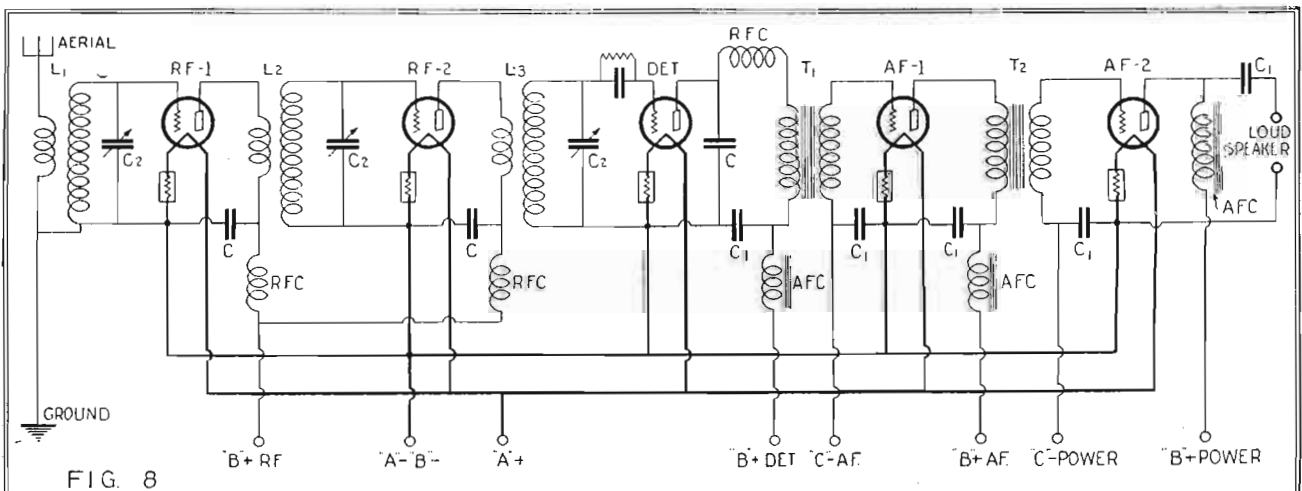

FIG. 8

In a tuned-radio-frequency receiver of the type shown here, both R.F. and A.F. filters can be used to

great advantage. Three of each will be seen in the schematic diagram above, one after each of the tubes.



# Radio Patents

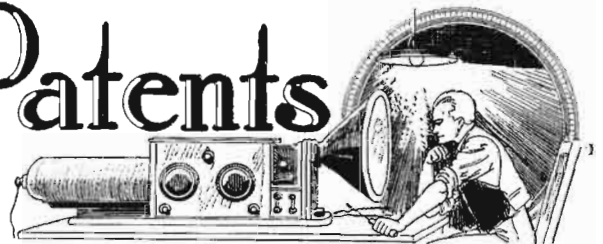

Compiled by Philip S. McLean\*

## A New Screen-Grid Tube

A BRITISH patent (No. 282,150) was recently granted to the well-known engineer, Capt. H. J. Round, for a further development of the screen-grid principle. The "space-charge" functioning of the screen-grid of a tube improves its characteristic, but has the disadvantage of the flow of current caused by the positive charge on this element.

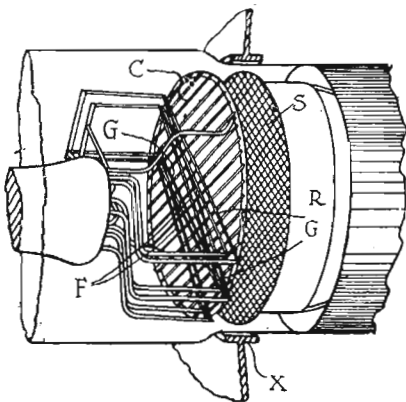

In the new design, this is sought to be overcome by making the space-charge grid out of one very fine wire, similar in shape to the filament, and directly between it and the control-grid. The introduction of this element causes the consumption of very little current.

The illustration shows a type of screen-grid tubes which has been developed in England; in the center is the W-shaped filament F, while the space-charge grid G, of exactly similar shape, is between the former and the control grid C. S is a screen-grid of metallic gauze fixed to a

cylindrical rim R; while the disc-shaped plate of this tube is concealed behind S. It will be seen that we have here a five-element tube. The development of tubes in Europe has been toward more diverse types and operating conditions than in America. (This patent is not available from the U. S. Patent Office.)

*READERS* desiring further information concerning any of the devices described briefly on this page, may obtain copies of the complete patent papers from the Superintendent of Documents, Government Printing Office, Washington, D. C. In ordering, merely give the number of the patent, and send ten cents in coin or money order (no stamps!) for each copy.

## Wavetraps in Transmitting Circuits

THIS invention is the insertion, in the grid circuits of oscillator tubes generating R.F. currents, of tuned frequency filters for the purpose of adjusting the phase relation between the grid potential and the plate current; and thereby, it is claimed, reducing the value of the necessary R.F. voltage on the grids. The fundamental frequency of the filter circuits should be approximately that at which "parasitic currents" tend to occur in the parallel grid circuits, although the inventor states that experiment has shown that it is not critical. This invention is relied upon to increase efficiency and stabilize the output of three-element-tube oscillators, particularly in the case of those operating at the shorter wavelengths (higher frequencies). It is designed to obviate the need often found for an

undesirably high value of inductance in the grid circuits which, in turn, causes unduly high voltages and makes the operation unstable.

(Patent No. 1,656,098, issued January 10, 1928.)

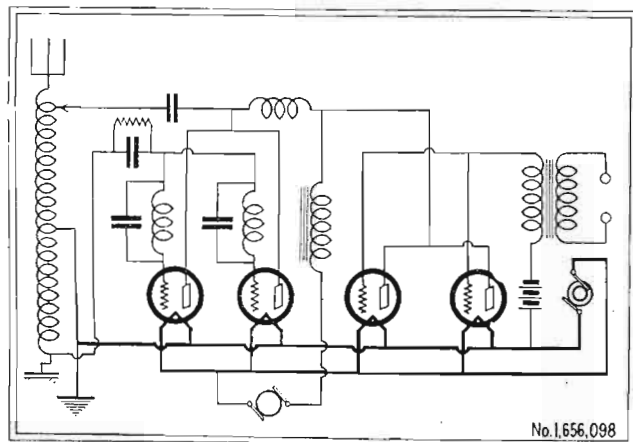

No. 1,656,098

*The diagrams on this page, taken from the patent papers whose numbers they bear, illustrate the fundamental principles claimed by the inventors.*

## A One-Way Aerial

TO overcome the tendency of the loop antenna to receive with equal sensitivity in two directions—that of the desired sig-

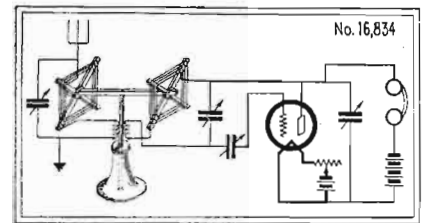

No. 16,834

nal and that directly opposite—as well as to eliminate the same ambiguity in loop-compass readings, is the purpose of this invention, which combines a vertical aerial with two loops fixed, as shown in the diagram, on a vertical pivot. The combination of the uniform all-around receptive characteristics of the vertical aerial with that of the loops results in a system which eliminates or reduces the effect of impulses from the direction opposite to that in which reception is desired. The second of the two

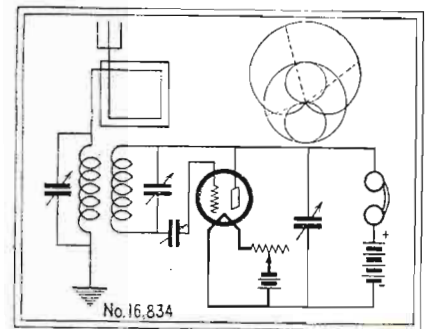

No. 16,834

loops is inductively independent of the first, yet coupled in energy-transfer relationship with the antenna path of the vertical aerial.

(This is a re-issued patent, No. 16,831, dated December 27, 1927.)

## Radio Clock Regulation Automatic

A SYNCHRONIZING system for correcting clocks automatically by time signals from NAA, or other radio stations broadcasting such in a regular code form on a fixed frequency at certain hours, is the subject of this patent, which continues the development of previous inventions from the same source.

The regulating impulses are received through a standard radio set, which may be

(Continued on page 1380)

\* Patent Attorney, New York, N. Y.

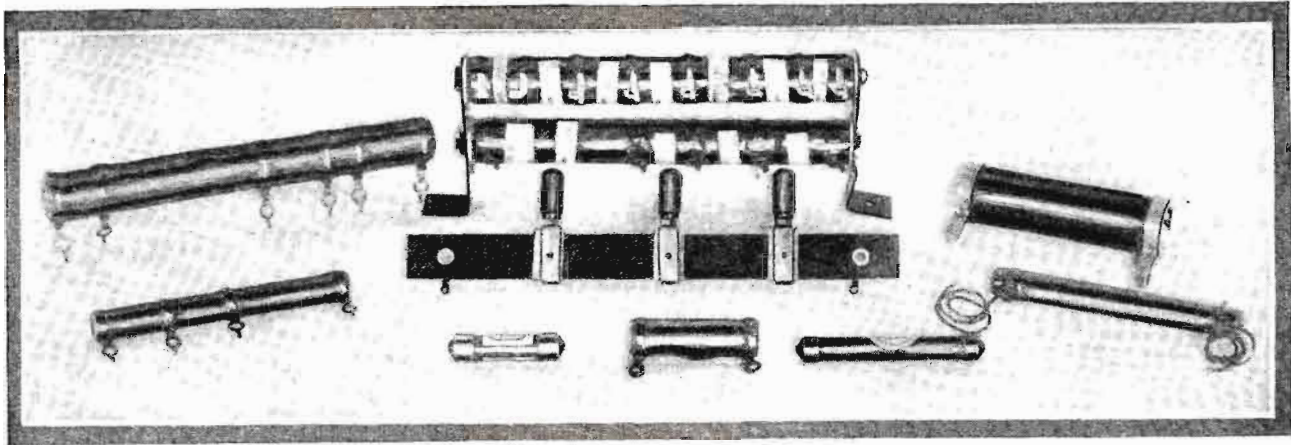

A group of heavy-duty resistors, of the type needed for voltage-dividing circuits in power units, are shown in the above picture. Most of the resistors are of the wire-wound type, and some are tapped so that various values of resistance may be obtained from a single component.

# Applying Ohm's Law to Radio Apparatus

Simple Rules for Computing the Values of Resistors Needed to Regulate the Direct-Current Supply to Receiver and Power-Unit Components



By Fred H. Canfield

ONE important cause of the poor results, too often obtained from home-made receiving and power equipment, is the unfamiliarity of the average experimenter with Ohm's Law. This fundamental electrical rule is applic-

able to every electrical circuit; and therefore to every electrical part of a radio receiver or a current-supply unit.

While many electrical studies demand a mathematical education of the very highest order, fortunately Ohm's Law is very sim-

ple, and common-school arithmetic (ordinary multiplication and division) is sufficient to work out problems which may arise under it. It may be stated forward or backward; and in its three formulas, will give the rules: (1) for determining the voltage "applied to" or "across," or "dropped in" a circuit when both the flow of current and the resistance in the circuit are known; (2) for determining the flow of current when both the voltage and the resistance are known; and (3) for determining the resistance when both the voltage and the current flow are known.

In every mail *RADIO NEWS* receives from readers many questions which the latter could easily answer for themselves with less trouble and delay, by a moment's application of Ohm's Law. For example, one letter inquires the proper size of a rheostat to control the filament current of three 201A-type tubes in the R.F. stages of a receiver; another asks data on the necessary resistance values of the units in a voltage-divider for use with a "13" socket-power unit whose output is 180 volts. In each case, the set builder should be able to find the answer quickly without having to write for it; and in each case it is easy to prove the answer and determine that it is correct.

### OHM'S LAW

Before giving illustrations of the solutions of problems, it is necessary to state the fundamental principle; this is the discovery of Professor Georg Simon Ohm, a German scientist, and was announced as long ago as 1826. (It may be said that, while its application is general, to alternating as well as direct currents, the presence of *inductance* and *capacity* complicates the problems of alternating-current circuits by changing the apparent resistance with every change of frequency; while, in a direct-current circuit, the resistance remains the same so

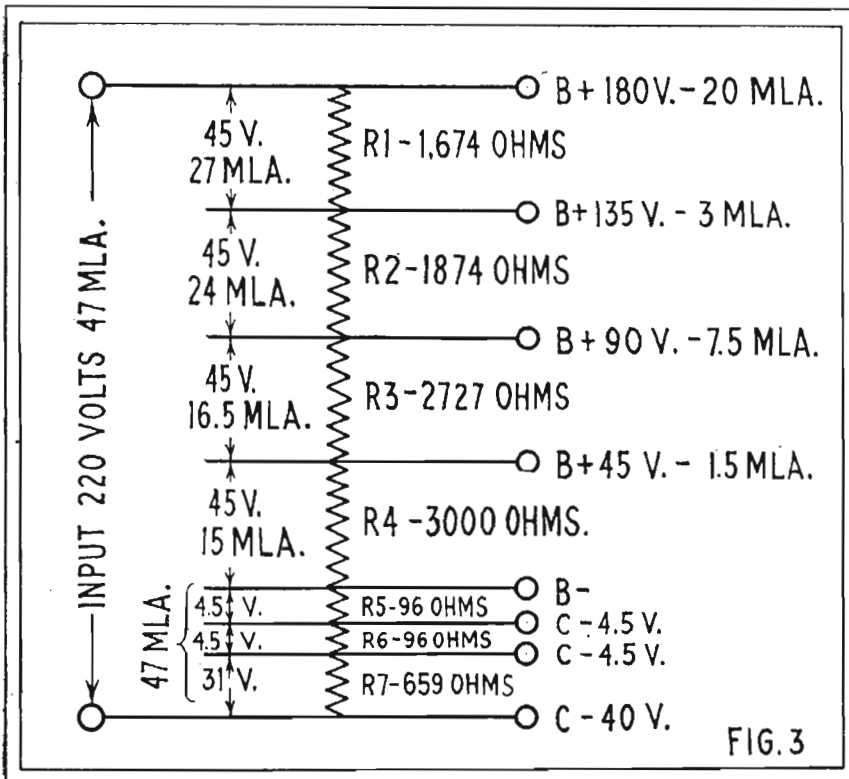

FIG. 3

"Ohm's Law" formulas are essential when designing a resistor bank for the voltage-dividing circuit of a "B" power-supply unit. The exact values of the various resistor units may be readily computed, if the current required by each of the tubes of the receiver, and the output available from the power unit, are known. The formulas are given and illustrated in this article.

long as there is no actual change in the elements of the resistors, conductors and insulators.) This is Ohm's Law, and is true of every electrical circuit:

*The voltage (or potential difference) existing in an electrical circuit is equal to the product of the current passing through the circuit by the resistance in the circuit.*

As the potential is expressed in volts, the current in amperes, and the resistance in ohms, we may say that the voltage equals the product of the amperes by the ohms. This is written as our first formula:

$$E = I \times R \quad (1)$$

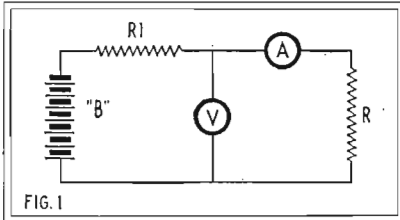

FIG. 1  
This diagram shows the laboratory set-up used for measuring the resistances of circuits or instruments.

E, in electrical engineering, signifies voltage ("Electromotive Force"); I stands for current ("Intensity") and R for resistance.

The above formula (1) is useful when we wish to know the voltage, and know the current and the resistance in the circuit. It is used, for instance, to convert a milliammeter into a voltmeter. A resistance of 1,000 ohms in series with the ammeter does this; for each one one-thousandth of an ampere passing through a resistance of 1,000 ohms in series with the meter does difference to exist between its two ends, as the formula above indicates.

We may turn this formula backwards in two ways. To determine the current when the applied voltage and the resistance are known, we use it in this form: current equals voltage divided by resistance, or *amperes equal volts divided by ohms*. Here is the second Ohm's Law formula:

$$I = \frac{E}{R} \quad (2)$$

An electrical fuse exemplifies this rule; when the voltage becomes too high, the current increases accordingly and burns out the fuse.

Or, supposing that we know both the voltage and the amperage, we can determine the resistance by dividing current into voltage: *ohms equal volts over amperes*. This is the third formula:

$$R = \frac{E}{I} \quad (3)$$

An instrument utilizing this principle is pictured on page 1225 of Radio News for May.

A TEST HOOK-UP

In the laboratory, the most frequent use of Ohm's Law is for measuring the resistance of circuits or instruments. Fig. 1 illustrates the circuit used for this purpose: in this case R is the resistance to be measured, V is the voltmeter which measures the potential or voltage across R, and A the ammeter measuring the current flowing in the circuit. B is a battery which provides the current, and R1 represents all other resistance in the battery circuit, such as that of wires, connections, etc., and even of the battery itself.

To illustrate how Ohm's Law is used, practical values will be given for the voltage and the current in the circuit of Fig. 1. If E (the voltage) is equal to 9 volts and I (the current) is equal to 0.5 amperes, then the resistance is equal to 9 divided by 0.5, or 18 ohms, by formula (3). (To divide by a decimal fraction, of course, the easiest way is to add to the number divided as many ciphers as there are figures pointed off in the fraction, and consider the fraction as a whole number; 90 divided by 5 is 18.)

Another use of Ohm's Law in a laboratory is to measure the voltage in a circuit when a voltmeter is not available. In this case we will say that R, the resistance, is known to be 15 ohms, and that the current has been found to be 3 amperes. Then, according to formula (1), the voltage is equal to 15 multiplied by 3, or 45 volts.

The third use of Ohm's Law is to measure the current passing in a circuit when the resistance and the voltage are known. For this example, let the potential be 30 volts and the resistance 5 ohms. Then, by substituting these values in formula (2), it will be found that the current is equal to 30 divided by 5, or 6 amperes.

IN THE "A" CIRCUIT

A practical way in which the set builder may use the formulas will now be considered. For an example, let us compute the proper resistance for a volume-control rheostat. Fig. 2 shows the circuit which will be used. V1, V2 and V3 are the three R.F. tubes of the set; their filaments are connected for parallel operation. B is a six-volt storage battery, R1 is the volume-control rheostat and R2 is a fixed resistor connected in series with R1. It is the purpose of R2 to prevent the voltage applied to the filaments of the tubes from exceeding 5; which is the maximum that should be used for operating 201A-type tubes.

The first step for the set constructor is to learn the resistance of the three tube filaments when connected in parallel. From the manufacturers' operating instructions it will be found that each tube, when operating at a potential of 5 volts, draws a current of 0.25-ampere from the battery; therefore, three tubes connected in parallel draw 0.75-ampere at 5 volts. By substituting these values in formula (3), it will be found the resistance of the three-tube filaments when connected in parallel is equal

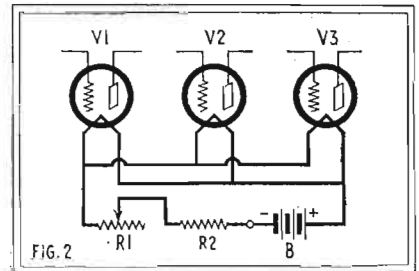
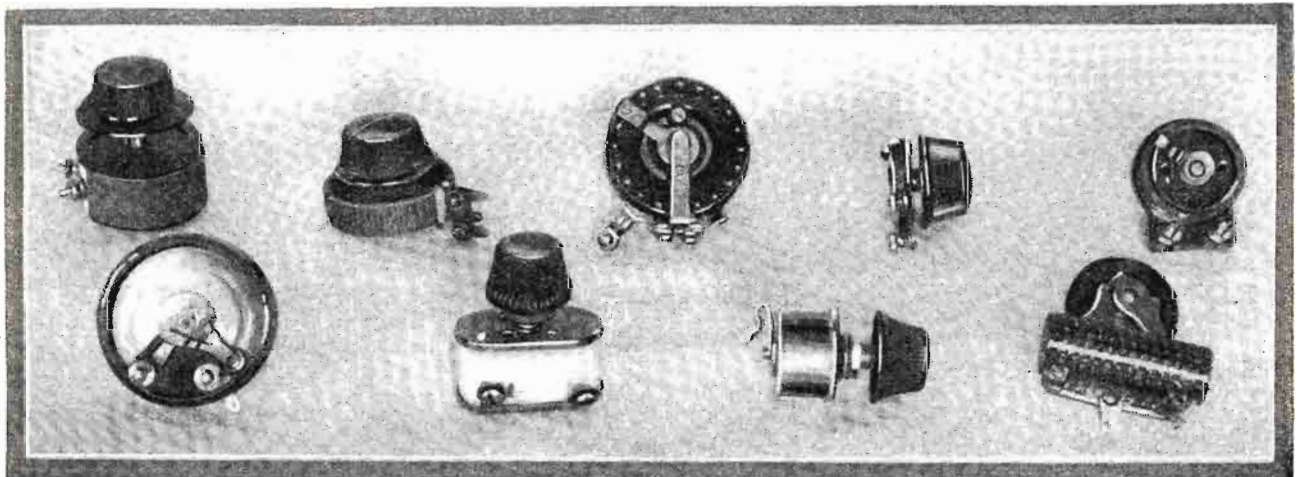

FIG. 2  
The correct values for the filament-control resistors (R1 and R2) may be calculated from the third Ohm's Law formula, given above.

to 5 divided by 0.75, or 6.6 ohms. The next step is to find the total resistance necessary in the circuit when a current of 0.75-ampere is flowing. This may be discovered by using the same formula; the voltage of the battery is 6 volts and this must be divided by the current, 0.75-ampere. By solving the formula, the total resistance will be found to be 8 ohms.

An examination of Fig. 2 will show that the total resistance of the circuit, when a (Continued on page 1358)



This picture illustrates the design of a number of different types of variable resistors. The units shown have different resistance values; the lower for use in filament circuits and the higher for voltage-dividing circuits. The three types most frequently used are shown; namely, wire-wound, carbon-compression, and carbon-strip. All three types are available in any desired value up to 50,000 ohms.

# What Our Readers Think Of Our New Policy

## MORE COIL DATA WANTED

Editor, RADIO NEWS:

My copy of RADIO NEWS reached me today. I have read with much pleasure your reversal of policy. It is all the more strange because of the fact that *Radio*, published in San Francisco, voices the same policy in an editorial in the current issue.



There is no gainsaying the fact that all of the radio journals have neglected the great army of radio fans and gone over almost entirely to the manufacturers of radio sets and parts. I presume I have one of the most complete sets of radio catalogs in the city; it stacks up nearly five feet high in a corner of my laboratory.

A case in point is the Browning-Drake. I have seen it described at great length in three different journals. One would think it was the very acme of perfection. It is a very good little set for four or five hundred miles, but compared to a good five-tube neutrodyne, it is absolutely worthless; mine now rests safe in the junk pile. As far as the neutrodyne is concerned, you will go a long ways to find its equal.

You will remember the hue and cry which was raised two years ago about single-control. I leave it to you as to who started it and why; anyway, the radio journals put it over. I will admit that RADIO NEWS has done better by us than any of the other magazines. You have given us a lot of coil and condenser constants, and I hope you will keep it up.

A subscriber asked the editor of *Popular Radio* why he did not give his readers more technical and descriptive articles and fewer descriptions of manufactured sets. The reply was that we had QST, and that was enough. A British correspondent asked *Popular Radio* for the coil constants of the LC26. The reply was that not many amateurs had the ability to wind a coil with the exactness required. Ye Gods, what a slam! My boy can wind a few coils on an oatmeal box and bring in any station on the Pacific coast. If it were a question of winding coils for a R.F. amplifier to be used with a gang condenser, there might have been some excuse for this. Mr. Cockaday referred all inquiries to the Precision Coil Company of New York City, whose price for the coils was \$5.50. I fell for this too—and now Mr. Cockaday's coils are also in the junk pile.

Mr. Gernsback, owners of radio sets are what make broadcasting possible, and all we want is a journal that recognizes this and gives us some consideration. As your correspondent from Los Angeles says, we don't need catalogs; we get all of them we need for *nothing*. We need technical articles for the advanced amateurs, articles for the beginner. We need to be told which end of a coil is the grid and which end the filament end. We need to be told the effect of winding the primary on one end of the secondary or in the middle or separated from the end of the secondary. We need to be told how many turns of different sizes of wire are necessary on a 2-inch form, on a 2½-inch form, or a 3-inch form to tune over the broadcast band with a .00035- or .0005-mf. condenser. Also, the effect when the same coil is placed in a shield. I had to find out this when I placed my coils in your Peridyne shields, and discovered that 468 meters was as high as I could tune.

MAXWELL HAMILTON,  
Porterville, Calif.

## A SYSTEMATIC STUDENT

Editor, RADIO NEWS:

I have just read your April editorial. I have read your magazine regularly for several years, but I have never subscribed.



The two reasons for this may interest you as the publisher, but I ask you to read them as editor. The "outsider" impression you speak of has been very strong. Not that it made any difference to me how much money you made, but it did seem as though the radio magazines existed primarily as an indirect advertising medium. This impression, of course, is not about RADIO NEWS alone, but included all the other generally-seen magazines; even *Radio Engineering*, to which I rather accidentally subscribed

several years ago. The continuous flow of "best-overs" became "Wolf, Wolf."

Yet the reason I continued to read radio magazines was that I wanted to learn more about radio. And so I did not subscribe: I bought two copies second-hand as soon as available, at 10c each. I took out the staples, cut out the articles which seemed, to me, to contain radio facts and punched them for a three-ring binder (letter size). Then I laboriously thumbed "Standards Circular No. 138," and got the index number as nearly right as I could. I bought two copies simply because so many

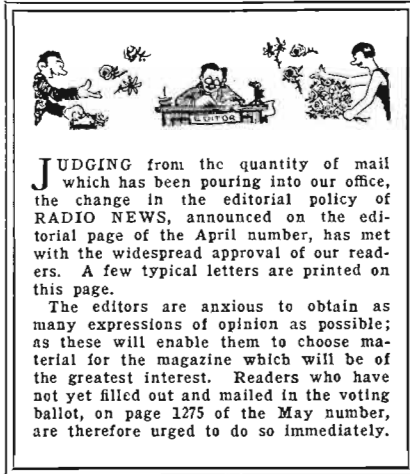

**J**UDGING from the quantity of mail which has been pouring into our office, the change in the editorial policy of RADIO NEWS, announced on the editorial page of the April number, has met with the widespread approval of our readers. A few typical letters are printed on this page.

The editors are anxious to obtain as many expressions of opinion as possible; as these will enable them to choose material for the magazine which will be of the greatest interest. Readers who have not yet filled out and mailed in the voting ballot, on page 1275 of the May number, are therefore urged to do so immediately.

of the articles to be saved overlapped, requiring a sadly large amount of time, scissors, and paste. Thus I have slowly got some dope together where I can find it under rational radio headings; and study it in what time is left, and add to it properly when more comes to hand. "Letax" saw the light in 1927. I subscribed. Now, Mr. Editor, have I been a lone plodder in my effort to accumulate radio information? I am no engineer, but only a "general reader" who owns a couple of B.C.L. sets, old ones at that.

All articles and "items" should carry somewhere in their title their correct "Dewey" number. The English magazine, *Experimental Wireless*, does that much, as you know. The second thing to do is not so easy. But some head work by the set-up man might make it possible to "back" and separate the news from the fact type of article, so that one copy of the magazine would do for filing purposes. Let me look in this April number: I've opened to page 1126. Well, now, wouldn't it be better to put page 1123 where page 1125 is, so that both the tube article and the S.W. article could be taken out for filing? *Radio Broadcast* does this in a half-hearted way, but does not print the Dewey numbers because "they feel it is not of wide enough interest to their readers"; yet it does give space to admirable, numbered summaries of radio periodical articles.

JOHN WEARE,  
1555 Massachusetts Ave.,  
Cambridge, Mass.

(Mr. Weare's suggestion about "making up" RADIO NEWS so that one article may be saved intact without spoiling the first page of the following article is a good one; but unfortunately mechanical difficulties make it practically impossible for us to follow it faithfully every month. Nor is the "Dewey" system understood by one in a hundred of our readers. In the particular case of the short-wave receiver our correspondent mentions, we might remind him that he can obtain complete, full-size blueprints covering the construction of this set by merely asking for them and sending ten cents in stamps to cover the cost of mailing.—EDITOR.)

## DISTRUSTS COMMERCIAL ENGINEERS

Editor, RADIO NEWS:

I have just purchased the April number of RADIO NEWS and, after reading your frank editorial, I have decided to give you my subscription for a year, beginning with the May issue.

I will be as frank as you and say that, while I have been buying RADIO NEWS from the newsstands for years, there have been many times when I was thoroughly disgusted with it, and swore I would never buy another copy; but fear that I might miss

something has kept me in occasional touch with it. There are three suggestions I would like to make:

(1) Eliminate the colored (rotogravure) sheets—at least the full page of the artists. These doubtless cost more than the regular sheets, and I don't think they get you anything. Personally, I don't care for them, and pay them no attention.

(2) If your writers are connected with manufacturing or selling concerns, do not show that information. The public reads between the lines (if at all) and lays off. I grant you that persons so connected are more capable of putting out real articles than most amateurs are; but just now they are on trial, with the circumstances already against them.



(3) Give the amateur a little more attention. He has just been recognized by the whole world, and he must be reckoned with. Besides, he is far more interested in radio than the average B.C.L.

The whole radio game as we have had it for the past few years is at its turning point and the magazine that comes clean with its readers will weather the storm. If you live up to the editorial mentioned, I see no reason why you can't continue to boast of radio's greatest magazine.

M. B. DRENNEN,  
510 St. Charles Ave., Birmingham, Ala.

## DIAGNOSIS AND PRESCRIPTION

Editor, RADIO NEWS:

You were kind enough to write me in response to a little note of mine written when my subscription to RADIO NEWS expired. You state the editorial policy of RADIO NEWS has been radically changed with regard to the publishing of "inspired" constructional articles. (Dr. Chase, whose letter was printed as part of the editorial on page 1097 of the April number, was informed of our change in policy before the magazine appeared.—EDITOR.)

As a lone, and for all I know, a peculiar, reader, my views and desires in radio magazine reading are of small value. I realize also that I know nothing of the business end or problems of your business. My impression is that the burden of expense falls on the advertiser; but that the rates he pays are determined by the number of subscribers, or the circulation. It would therefore seem to me an excellent idea to so edit your magazine that most "radio fans" would be readers. To me it seems that radio editors in general assume that radio fans are mentally poor and morons. They publish an article on how to "construct" the "XYZ" receiver, but the article is not a constructional article. It calls merely for the assembly of the manufactured radio parts of the "XYZ" company—which, of course, "inspired" the article. The finished set may be good, bad or indifferent. Of what educational value is such an article? How much reliance can be placed on the description contained in the article of the "XYZ" set's selectivity and sensitivity? None at all, naturally. Such articles prostitute a magazine, cause its readers to distrust it, and do not really do justice to the "XYZ" products.

I am a physician, and radio is my hobby. Naturally, I know many "hams," "B.C.L.s." and "fans," to whom I have talked. All appear to be disgusted with the radio magazines now on the market because of these "inspired" articles and the paucity of real radio educational articles. From my little viewpoint, I believe a radio magazine that would publish sound and trustworthy articles of educational value on radio (and I don't mean highly technical, either), together with a section on "Trouble Shooting," "Questions and Answers," "Book Review," and construction articles that describe the home construction of parts

as well as the assembly, could not help but have a large circle of readers; the size of the circle being directly proportional to the trustworthiness and value of the articles printed. Any widely-read magazine should not lack advertisers. I believe that when you betray and belittle your readers you are killing the goose that lays the golden egg, even though the advertisers are the financial backbone of the publishing business,

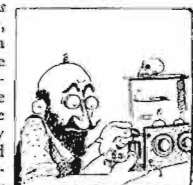



I have not found among my friends any who are interested in the pictures or studio articles such as you publish, or in fiction stories, or other material that to me appears expensive and irrelevant.

I will mail you a copy of the Journal of the American Medical Association if you say the word. Here is a trustworthy magazine devoted to its readers.

FRANK H. CHASE, M.D.
2362 W. 21st St., Los Angeles, Calif.

APPROVES FREE BLUE PRINTS (MOST DO)

Editor, RADIO NEWS:
Had you not changed your policy, I would have changed to another magazine.

How often I have wished for the number of turns of coils, the capacities of fixed condensers, etc., instead of makers' product-names!

A very few of your readers are capable of building the new A.C. sets. Therefore, it is a wise move to describe sets they can build from parts which are easily obtainable and to accept advertisements for finished products in your regular advertising columns.

The blueprints at 10 cents each will be acceptable to many who, like myself, would prefer the blueprints to build from, irrespective of the fact that they show manufacturers' names for specified parts.

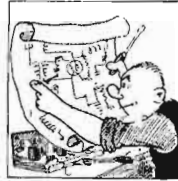

HENRY WENZEL,
81 Keap Street,
Brooklyn, N. Y.

SHORT-WAVE DATA DESIRED

I certainly approve of your new policy of not hoisting any article by the manufacturer's name.

However, if the piece of apparatus used is in any way unusual, a minute description of its construction should be given.

I also thoroughly approve of your recent attitude of adding what might be called a short-wave department. There are thousands in the country who have a B.C. set in their home, and in the basement or attic a "ham" station.

J. G. WILBOURNE,
Birmingham, Alabama.

BUT THERE ARE FEW MATHEMATICIANS

Editor, RADIO NEWS:
I wish to take this opportunity of commending your new policy. For the past year or more you have published more radio junk than ever before.

Personally, I think your journal would do much better if it featured more technical articles of a semi-scientific and mathematical turn and not so much material of a purely pictorial and amusement value.

WILLIAM E. MUNROE, M.D.,
303 Alexander Street,
Rochester, N. Y.

FROM A DX LISTENER

Editor, RADIO NEWS:
I wish to compliment you upon your statement of a changed policy for RADIO NEWS. For several months I had been disgusted with the policy of (Continued on page 1353)

List of Broadcast Stations in the United States

(Continued from page 1318)

Table with 12 columns: Radio Call Letter, Broadcast Sta. Location, Wave (Meters), Power (Watts), and corresponding information for stations across the United States.

\*Allowed higher daylight power. \*\*Standard or constant-frequency transmission. †Remote Control.

LIST OF CANADIAN BROADCAST CALLS

Table with 4 columns: Call Letter, Location, Wave (Meters), and Power (Watts) for Canadian broadcast stations.



# Radio News Laboratories

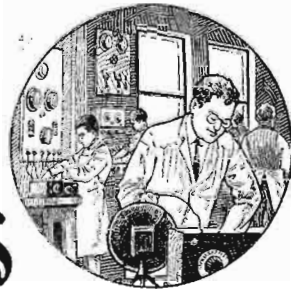

**R**ADIO manufacturers are invited to send to RADIO NEWS LABORATORIES samples of their products for test. It does not matter whether or not they advertise in RADIO NEWS, the RADIO NEWS LABORATORIES being an independent organization, with the improvement of radio apparatus as its aim. If, after being tested, the instruments submitted prove to be built according to modern radio engineering practice, they will each be awarded a certificate of merit; and those apparatus which embody novel, as well as meritorious features in design and operation, will be described in this department, or in the "What New in Radio" department, as its news value and general interest for our readers shall deserve. If the apparatus does not pass the Laboratory tests, it will be returned to the manufacturer with suggestions for improve-

ments. No "write-ups" sent by manufacturers are published in these pages, and only apparatus which has been tested in the Laboratories and found of good mechanical and electrical construction is given a certificate. As the services of the RADIO NEWS LABORATORIES is free to all manufacturers, whether they are advertisers or not, it is necessary that all goods to be tested be forwarded prepaid, otherwise they cannot be accepted. Apparatus ready for, or already on, the market will be tested for manufacturers free of charge. Apparatus in process of development will be tested at a charge of \$2.00 per hour required to do the work. Address all communications and all parcels to RADIO NEWS LABORATORIES, 230 Fifth Avenue, New York City. Readers may obtain manufacturers' names from the "I Want to Know" department—see page 1355.

### TRIPLE SWITCH

This rotary switch is of the triple-pole, double-throw type. Its hard-rubber base is two inches in diameter and approximately 5-16 inch thick. The contact springs are made of phosphor bronze and slide smoothly



over the points, with which they make a perfect contact: an "OH" position is secured by dummy contact points. The switch is made for mounting with screws and nuts, and is of very neat construction.

AWARDED THE RADIO NEWS LABORATORIES CERTIFICATE OF MERIT NO. 2327.

### A.C. ADAPTOR HARNESS

This harness makes it possible to convert to A.C. operation a five-tube "A"-battery-operated receiver which uses a power tube in the last stage, and is designed to operate in connection with "A" power transformers which have center taps in their low-voltage windings. This harness consists of three separate parts; one is formed of two variable regulating resistors and three adaptor sockets of the four-prong type, connected to a cable made of flexible rubber-covered conductors. The second sec-

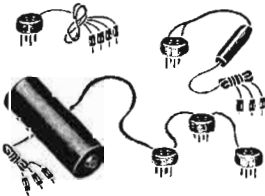

tion contains a four-prong adaptor and a resistor of 1,950 ohms cabled together. The third section consists of a five-prong adaptor socket, attached to a three-lead cable. The two controlling resistors are of the rotary type and are housed in a bakelite tubing 3/4 inches long and 1 1/4 inches in diameter; their resistance values are, filament control or regulator, 0.2 ohms, and "C" bias regulator, 953 ohms.

AWARDED THE RADIO NEWS LABORATORIES CERTIFICATE OF MERIT NO. 2328.

When the windings of an "A" power transformer, which is used to convert a five-tube battery receiver with power stage to A.C. operation, have no center taps, the harness

shown here may be used. It consists of two separate sections: one is composed of four adaptor sockets of the four-prong type and two center-tapped resistors, all connected together to a cable of the same type as used in the harness described above. The other section consists of a five-prong socket and a center-tapped resistor connected to a three-lead flexible cable. The two center-tapped resistors of the former section have resistance values of 20 ohms and 43 ohms and are, respectively, connected across the 1.5-volt and the 5-volt supply. The centers are sol-

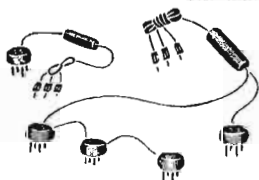

dered to the common negative return lead.

AWARDED THE RADIO NEWS LABORATORIES CERTIFICATE OF MERIT NO. 2329.

### A.C. POWER PACK

The power pack shown here is designed for radio receivers operated directly from the 110-volt, 60-cycle, house-lighting system, and which employ tubes of the 226, 227 and 171 types and rectifiers of the 280 type. This pack contains, in one metal housing, the power transformer and two 30-henry chokes. The five output windings of the transformer supply: 4 amperes at 1.5 volts, 1.75 amperes at 2.25 volts, 2 amperes at 5 volts, 0.5-ampere at 5 volts, and approximately 60 milliamperes at 250 volts. The two 5-volt windings and those for the high-voltage supply are center-tapped. At full load the out-

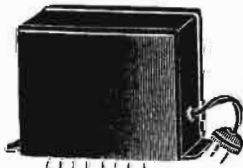

put voltages have been found to have practically the rated values. The outside dimensions are 5 3/8 inches long by 3 1/2 inches wide by 4 3/8 inches high.

AWARDED THE RADIO NEWS LABORATORIES CERTIFICATE OF MERIT NO. 2330.

### A.C. POWER PACK

Another power pack, submitted for test by the same manufacturer, is

built on the same principles as the item described above. It has only slightly larger outside dimensions and has a greater output. It is designed for receivers employing six or seven tubes of the 226 type, one 227 type, one or two power tubes of the 171 type, and a rectifier of the 280 type. The high-voltage winding supplies 60 milliamperes at approximately 280 volts, with all the low-voltage windings under full load.

AWARDED THE RADIO NEWS LABORATORIES CERTIFICATE OF MERIT NO. 2331.

### POWER TRANSFORMER

This transformer is designed to convert a storage-battery-operated receiver into an A.C.-operated set, employing tubes of the 226, 227 and 171 types. It operates from the 110-volt, 60-cycle house-lighting system, and has three output windings supplying current at 1.5, 2.25 and 5 volts; the last two windings are center-tapped. The ends of the 1.5-volt winding are connected to a balancing potentiometer, which is intended to eliminate the A.C. hum. A resistance strip, with values of 165 ohms

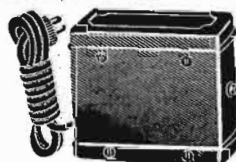

and 3,450 ohms, provides the biasing voltages for the tubes. This transformer is well built and mounted in a black-japanned sheet iron case. The ends of the output windings and the center taps are connected to eight terminals which are mounted on a bakelite panel inside of the housing.

AWARDED THE RADIO NEWS LABORATORIES CERTIFICATE OF MERIT NO. 2332.

### A.C. ADAPTOR HARNESS

The adaptor harness shown here is designed for the transformation of a six-tube battery-operated receiver into an A.C. type. It operates in

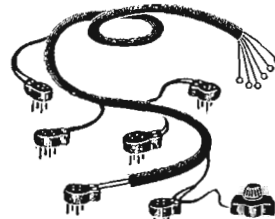

connection with the transformer of the same make, mentioned above. It consists of insulated flexible conductors, braided into one cable, the

ends of which are attached to six adaptor sockets. Five of the adaptors are of the four-prong type and one has five prongs for a 227-type detector. A volume control of approximately 340,000 ohms is attached to the adaptor corresponding to the second R.F. stage.

AWARDED THE RADIO NEWS LABORATORIES CERTIFICATE OF MERIT NO. 2333.

### CONE SPEAKER

This reproducer is of the double-cone type and 36 inches in diameter;



the diaphragm is made of a special cone paper and is characterized by the fact that it assumes the shape of a folded cone, which is concave in the center. The unit used in this speaker is of the floating-armature direct-drive type. The reproduction of music and speech from this loud speaker has been found very satisfactory.

AWARDED THE RADIO NEWS LABORATORIES CERTIFICATE OF MERIT NO. 2334.

### VARIABLE CONDENSER

Excellence in electrical and mechanical design, workmanship and finish is manifested in the variable

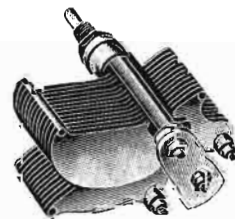

condenser shown here, which is of the one-hole mounting type, and has twenty-seven plates. Plates and frame are made of brass. Spacing rods on the stator and rotor assure rigidity and permanency of calibration. The maximum value of this condenser is 564 mmf. and its minimum approximately 12 mmf. With regard to its capacity characteristics, this condenser can be considered as

a combination of the two types, S.L.W. and S.L.F.; it is closer to the former type at the lower readings of the dial (up to 40), and almost identical with the second type from 40 up. It is of Norwegian manufacture.

AWARDED THE RADIO NEWS LABORATORIES CERTIFICATE OF MERIT NO. 2335.

**A.C. FILAMENT BALLAST**

The resistor shown here is designed for use in series with tubes of the 226 type, when operated from transformers which supply the filament current at approximately two volts. The resistance value of this ballast varies with the current flowing through it. It is 0.25-ohm at



0.7-ampere, and 0.65-ohms at 1.5-amperes. A tube of the 226 type, which requires for normal operation 1.05 amperes at 1.5 volts, when in series with this ballast will take approximately 1.1 amperes if connected to a current supply of two volts.

AWARDED THE RADIO NEWS LABORATORIES CERTIFICATE OF MERIT NO. 2336.

**SPEAKER UNIT**

This speaker unit is of the well-known balanced-armature type. The vibrating armature is connected in-

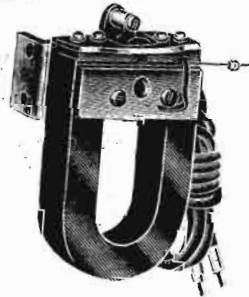

directly through a lever system to the diaphragm. The end of the connecting rod is threaded, and can be attached to the apex of the cone with two nuts. The nickel-plated brass frame of the unit is provided with a heavy bracket which enables easy mounting. The horn-hoe mag-

net is not drilled, but is clamped in its position. This unit is compact, well-constructed and of a very neat finish; it is sensitive and is capable of operating under the heavy outputs of modern radio receivers using power tubes.

AWARDED THE RADIO NEWS LABORATORIES CERTIFICATE OF MERIT NO. 2337.

**RIGID-CONE DIAPHRAGM**

The cone diaphragm shown here is of interesting construction, and is capable of delivering very good reproduction, with regard to quality and volume, when operated by a well-designed speaker unit. The paper cone proper, which is 7 1/2 inches in diameter and has an included angle of approximately 120 degrees, is glued to a thin ring of balsa wood, 7/8-inch wide. Soft, flexible strips of kid leather, forming an annular border, attach the balsa wood ring to another made of cardboard. This second ring, which is of cardboard 3/4-inch thick, 1 1/2-inch wide, and has an outside diameter of 10 1/2



inches, is intended for the mounting of the cone on the cabinet. The total weight of the cone is approximately 1 1/2 ounces.

AWARDED THE RADIO NEWS LABORATORIES CERTIFICATE OF MERIT NO. 2338.

**REPRODUCERS**

The driving unit and the cone described above are used as repro-

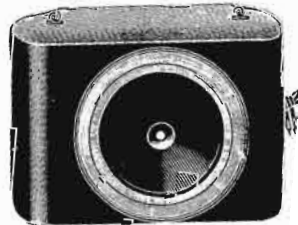

ducing elements in the speaker shown here. The housing of this speaker is 10 1/2 inches high, and has an oval base approximately 5 1/2 by 15 inches. It is designed for inclusion in the radio cabinet; it is provided with a special spring suspension intended to prevent the mechanical vibrations from being transmitted to the tubes, and thus avoid microphonic howling.

AWARDED THE RADIO NEWS LABORATORIES CERTIFICATE OF MERIT NO. 2339.

The loud speaker shown here is



similar in construction and in performance to the above reproducer, but is designed for table use, and has its working parts encased in an attractive cabinet made of fumed oak. This and the preceding three items are of German manufacture.

AWARDED THE RADIO NEWS LABORATORIES CERTIFICATE OF MERIT NO. 2340.

**SPEAKER-CLOTH VARNISH**

Many diaphragms for reproducers of the cone type are made of various cloths impregnated with a varnish to give suitable tension. The tin shown here contains a preparation



which has celluloid as a base, and which can be used very successfully for the treatment of diaphragm cloth; it offers therefore an open field for experimental work on cone speakers. The consistency of this varnish may be regulated by a special thinner.

AWARDED THE RADIO NEWS LABORATORIES CERTIFICATE OF MERIT NO. 2341.

**SPEAKER UNIT**

The speaker unit shown here is of the balanced-armature direct-drive

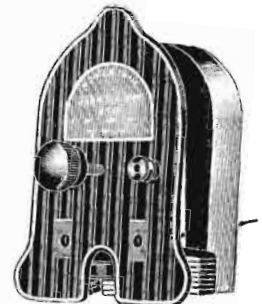

type. It is designed for use with speakers of the cone type, and equipped with an adjustment knob. Although very simple in construction, it gave satisfactory results when tested in connection with a well-designed 24-inch cone.

AWARDED THE RADIO NEWS LABORATORIES CERTIFICATE OF MERIT NO. 2342.

**TUBE-PRONG POLISHER**

Unsatisfactory operation of radio receivers and noisy operation is very often due to imperfect tube contacts. The device shown here is therefore very useful, as it provides the prongs of vacuum tubes with perfect contact surfaces. It is simple in construction and simple in operation; it consists of a hollow wooden dowel, 2 1/2 inches long and 1/2-inch in diameter, provided with two lengthwise saw-cuts or slots. A small square of emery cloth is introduced into each hollow end of the dowel through the saw-cuts, and is held in position by rubber bands. The tube prong fits into the hollow portion of the dowel,

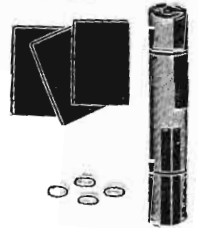

and is polished thoroughly by twisting the device.

AWARDED THE RADIO NEWS LABORATORIES CERTIFICATE OF MERIT NO. 2343.

# What Our Readers Think of Our New Policy

(Continued from page 1351)

the magazine; and my view was shared by many of my friends. Several of us fans had about decided to discontinue buying; but I know we will continue getting it from now on.

In regard to chain broadcasting, I am very much opposed to monopolies which become czar-like in their dealings with the public; but I do think chain broadcasting is legitimate.

And, as far as powerful New York stations are concerned, the more powerful, the better for us. We in the tropics have a true understanding of "low-pressure areas" and static. We have more unfavorable weather in a year's time than good weather. Whenever the signal comes in stronger than the noise, we are tickled to turn down the controls and put on the headphones—using a super-heterodyne.

Finally, most people in Florida have WEA and WJZ programs on 90% of the time the set is turned on. This applies to dealers' store demonstrations and to music in the homes. We hope the new Radio Commission won't cut down the power of the New York stations and deprive us of a fighting chance to have radio during the summer.

May I also make one suggestion for the magazine? If the organization of material in the magazine would permit, it seems to me it would be more convenient for the readers if the entire list of

stations was put on two consecutive pages. That would allow the reader to tear them out and paste them on a sheet of cardboard for ready reference. Thank you for wading through this.

Lewis F. Eckert,  
Lake Worth, Florida.

(For the past two years, the unduly-long roll of broadcast stations has been a nightmare to the editors as well as to the licensing authority; no month's issue could contain an up-to-date and correct list of stations, because there were always numerous changes during the four weeks necessary to print and distribute the magazine. We are hoping for better days, when the permanence of a list will permit of putting it in more convenient form. Incidentally, the only way of putting the list on two pages that can be cut out without mutilating two other articles is to print them back to back; and this would not permit of pasting them up, as Mr. Eckert suggests.—EDITOR.)

**A HAND ACROSS THE SEA**

Editor, RADIO NEWS:

The letter which you publish as an inset to your editorial in the April number of RADIO NEWS strikes me as an example of monumental ingratitude.

Surely your subscribers must recognize that any journal is dependent on its advertisers for its financial success; and, so long as you continue to deliver the goods as far as the interests of "fans" (or "amateurs," as we say over here) are concerned, it is not their business to criticize the methods you see fit to employ in order to make that success secure.

I assure you that RADIO NEWS is appreciated over here, not only for the general interest and excellence of its technical articles, but also for your fairness in regard to the radio achievements of the nations.

One reference to the practical point—when we see a manufacturer's name appended to a component mentioned in RADIO NEWS, we know that it is of good quality; and on that subject, also, we need more guidance than on any other.

An English M.D.,  
Old Trafford, Manchester, England.

(The problem before RADIO NEWS was to choose between the demands of readers and those of advertisers; the former, being in the large majority, necessarily carried the day. While a large number of letters express the broad viewpoint of the above, they are outnumbered ten to one by those commending the inclusion of "tie-up" articles and thus, depending on one manufacturer's product.—EDITOR.)



# Radiotics



### HOT STUFF, M' LIEGE!

Report in the *Los Angeles Evening Press* of February 21st, that George V. well-known monarch, has trouble with his receiver: "His Majesty was shown a FIRE-tube set with a guarantee that he could get what he wanted on it." Maybe Royalty is going to use these new tubes for pulling in warm numbers from Paris and Berlin.

Contributed by L. S. Smith

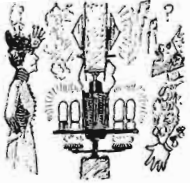

### HOW'S THIS DONE?

Peculiar constructional information dispensed by the *New Haven Sunday Register* of March 4th: "Twenty-two of the tubes are 210s, which are placed in the single audio stage." Off-hand we should say that, with an audio amplifier like that, music should be heard at least across a room. What do you think?

Contributed by H. Nafal



### WALK RIGHT IN

Interesting item from the *Radio World* of February 18th: "It is positively single dial control, once a KNOCK on the panel adjusts the antenna secondary circuit..." No, Oscar, this does not mean that you have to have a plug-ugly with every set, to beat it into submission. Just use a hammer on the thing yourself.

Contributed by Mrs. R. E. Weaver

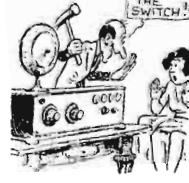

### HOW HIGH IS A DOLLAR?

A plaintive tale from the *Columbus Evening Dispatch* of February 28th: "Have had real good success, except I can't get anything loud above \$65, which is WLW, WJR..." These are most likely some of those high-priced wavelengths we have been hearing about during the pow-wow down in Washington; what can be done to reduce the H. C. of R.?

Contributed by Cydnor Tompkins

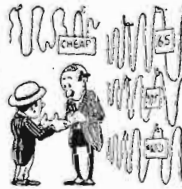

### WE PREFER "NON-REFILLABLES"

In *Hamilton-Carr's* catalog we find the following advertisement: "Long-Wave FILLER Transformers." Mike of the Investigation Dept. reports that these transformers are used in the receivers in night-clubs, where apparently radio is playing mere and more important roles in the entertainment.

Contributed by Roskind Bohstedt



### STEALING A MARCH ON WEVD

Political gesture in the *Youngstown Daily Vindicator* of March 13th: "8:30 --A. & P. Gypsies; this popular orchestra tonight will have a harp SOCIALIST, Signor Cella." This is starting in the campaigns pretty early this year, we should say, and with a minority party, too. Well, whom are you betting on? Place bets with Mike of the I. D.

Contributed by L. H. Minnick



### PAGING OLD MAN ATLAS

In the *Newark Star Eagle* of March 5th we find mentioned a loud speaker that "will take a full load from a power BACK." Our guess is that the gentleman who has been holding up the sky all these years has at last become tired and this new instrument has been designed to give him a lift.

Contributed by Eric Patky



IF you happen to see any humorous misprints in the press we shall be glad to have you clip them out and send to us. No RADIOTIC will be accepted unless the printed original giving the name of the newspaper or magazine is submitted, with date and page on which it appeared. We will pay \$1.00 for each RADIOTIC accepted and printed here. A few humorous lines from each correspondent should accompany each RADIOTIC. The most humorous ones will be printed. Address all RADIOTICS to

Editor, RADIOTIC DEPARTMENT, c/o Radio News.

### HOW COME? HOW COME?

The *Hamilton (Ohio) Daily News* of March 15th informs us, through an advertisement, that there is for sale, among "Used Radios," "One Radiola SUPER - HEAT complete with speaker \$100." Well, that looks as if the R.C.A. is going into the boiler business. When the temperature drops we suppose that the speaker tells you what to do.

Contributed by Frank F. Wessel



### MODERNISTIC FURNITURE?

Trend towards the new furniture mentioned in the *Rochester Times-Union* of February 21st: "There are now between 300,000 and 400,000 receiving SEATS in that state." We suppose that every time anyone sits in the radio seat the loud speaker starts up. "Stough on the wearied patriot when they play the 'Star-Spangled Banner,' isn't it?"

Contributed by Leslie E. Caltin



### WE HA'E OOR DOOTS

History of radio, as told to Congress by Judge Manton Davis on behalf of the R.C.A.: "The Marconi Co. had equipped its stations with the spark type of apparatus which furnished DAMP waves." Some of our readers will be anxious to know what kind of wetness was thus provided. We decline to say; except that there seemed to be some suspicious-looking coils about, at times.

Contributed by John M. Fishell



### LIKE THE ROCK OF GIBRALTAR

Everlasting motif from the *Radio World* of March 3rd, in a caption under a photograph of a receiver: "The ETERNAL appearance of the time-signal amplifier." That again raises the question, how long is eternity? Mike, the trusty investigator, reports that it's from payday to payday; but we say it's the time between drinks.

Contributed by J. W. Crover



### WOOF! WOOF!

The S. P. C. A. will please notice the advertisement in the *Pittsburgh Press* of February 26th: "Radio wanted for police pup, 9 months old." Hasn't that pup the kind owner? Our guess is that either the mutt howls so much at night that the master thought he'd drown him out with a radio; or else the radio is intended to entertain the dog.

Contributed by John H. Wack



### THE AMATEUR'S ASSISTANT

Progress of invention foreshadowed by an advertisement in the *New York Times* of March 20th: "ARMAGRAPH wanted, also key buzzer and phones." Evidently the device described is one which will aid in the desire of some ambitious ham to work all continents -- at once. We suppose it is able to pound brass with all of its numerous arms while the owner watches the meter. --Contributed by Eric Minnick.

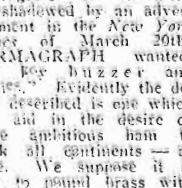

### FASHIONS FROM INDIA

In the *Calcutta Statesman* of February 5th the following advertisement was brought to our attention: "Wireless Apparatus! For Sale - Stamped Velour CLOTH COAT, dark gray, fur collar, lined satin throughout..." Perhaps there is some new style in India that decrees that Miles should have music wherever she goes.

Contributed by C. M. Sweet (India)



### WHAT THE WELL-DRESSED SET WILL WEAR

Fashion note from the *Portland Oregonian* of March 11th: "Tubes Have Long LINES." Now, you set designers, see that the tubes you use have that much-to-be-desired long-waisted effect, or else the up-to-the-minute fan won't have anything to do with your latest creation.

Contributed by B. A. Oscarson



### AND ON THE RIGHT--

A new *Odyssey of Progress* is set forth in the advertisement of Conrad in *Radio News* for March: "All About Radio Parts should go with every radio; it takes you through every radio part." We are not as thin as in the days of old, and we fear it will take a long tug to get us through between the tuning-condenser blades; but when it comes to the fitter chokes--we must resign in favor of Mike. --Contributed by Miles Martin.



### NO PEDESTRIAN SETS PERMITTED

President McDonald of the Zenith Radio Corp. announces, through the *New York Times* of March 14th, that his company "will immediately begin redesigning every receiver in its line for AUTOMOBILE tuning." Sound your horn, throw the gear into a high wave, and step on the volume control. We're off!

Contributed by B. M. Bergin





Conducted by C. W. Palmer

RADIO NEWS readers send in every month an average of 5000 letters asking information on every phase of radio theory, construction and operation. We can only print the five or six replies which are of widest general interest.

Other letters will be answered by mail, if inquirers observe these rules: BE BRIEF: TYPEWRITE OR WRITE LEGIBLY IN INK ON ONE SIDE OF THE SHEET ONLY: ENCLOSE A STAMPED ENVELOPE ADDRESSED TO YOURSELF. Many letters are not readable. Simple questions will be answered free;

those asking for sketches, diagrams, data, etc., should send TWENTY-FIVE CENTS FOR EACH QUESTION; failure to enclose this will cause delay. We cannot answer for this sum questions requiring original research, intricate calculation, or patent investigation; we cannot compare the merits of trademarked apparatus, or give constructional data on apparatus whose makers withhold it. We cannot undertake to answer more than THREE QUESTIONS in each letter. If you inquire concerning a circuit which is not a standard, published one, enclose a diagram to save delay.

**MATCHING LOUD SPEAKERS**

(2278) Mr. E. A. Seip, Charleston, S. C., writes:

(Q.) "I have seen, in several magazines, methods of using cone and horn loud speakers together to improve the quality of reception. However, the methods of controlling the volume of each loud speaker were not given, and coupling the two speakers together without this control does not

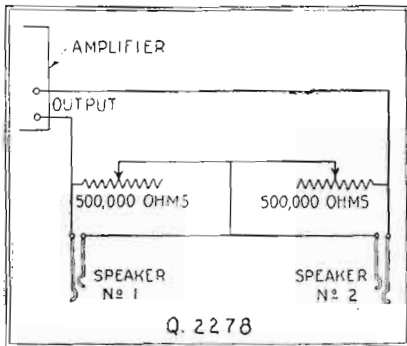

By this arrangement, two loud speakers may be so balanced that better quality will result. Individual volume control for remote loud speakers can also be obtained in this way.

improve the tone quality. Can you show me how this may be done?"

(A.) The diagram (Fig. Q. 2278) shows how two speakers may be connected so that either one may be controlled without affecting the operation of the other. Two variable resistors are shunted across the speakers and serve to control the volume of each. By placing speakers of the cone and horn types together and carefully balancing the volume of each, remarkable fidelity of reproduction may be obtained. This is due to the fact that most cone speakers reproduce the lower notes better than the high ones; while most ordinary horn speakers tend to weaken the lower tones. (This statement does not apply to large horns of the true exponential type, such as the one described on page 1342 of this number.)

This method of coupling is of service also when two loud speakers in separate rooms are being used with the same receiver. If the speakers are coupled together in the normal manner, both must be operated with equal volume. Very often it is desirable to have one speaker operating very softly and the other loudly. This control can be obtained quite satisfactorily by the method described.

**NECESSITY OF "B" BATTERY SWITCH**

(2279) Mr. R. Linden, Buffalo, New York, asks:

(Q.) "Why is it not necessary to have a switch in the 'B' battery circuit to disconnect this battery

when the set is not in operation? Most people are very careful to turn the 'A' battery switch off when they are not using their receivers, but very few bother to disconnect the 'B' batteries. What is the reason for this?"

(A.) The reason why this switch is not necessary is shown in Fig. Q. 2279. By referring to this diagram you will see that when the filament is not connected to the "A" battery, no electrons are flowing between the filament and the plate. Since the "B" battery circuit is completed through this electron-flow in the tube, "B" battery current can only flow when the filament is hot. It may be true that a very small amount of current passes through the circuit, due to leaks in the tube base, etc.; but for that matter, there are leakage currents through the battery cells themselves, even with the "B" battery entirely disconnected from the receiver. However, these leakage currents are extremely small and are not worth mentioning. A more complete description of vacuum-tube action will be found in "The Radio Beginner" department of the April, 1928, issue of Radio News.

**AN A.C. PUSH-PULL AMPLIFIER**

(2280) Mr. I. W. Johnston, New Orleans, La., writes:

(Q.) "I would like to obtain the constructional details for building a push-pull amplifier, employing one stage of ordinary transformer-coupled amplification, and one stage of push-pull amplification. A 112A-type tube will be employed in the first stage, and 171As in the second stage. The filaments of these tubes will be operated from a 5-volt transformer, and the 'B' supply will be obtained from a 'B' power unit."

(A.) The diagram you request will be found as Fig. Q. 2280. The apparatus used is as follows:  
 One audio-frequency transformer, T1;  
 One push-pull input transformer, T2;  
 One output choke or transformer (push-pull type), T3;

- One 112A-type tube;
- Two 171A-type tubes;
- Three vacuum-tube sockets;
- One 40-ohm tapped resistor;
- Eleven binding posts;
- One wooden baseboard, 6 x 12 x 3/4 inches;
- One binding post panel, 3 x 12 x 3/4 inches, bakelite or hard rubber;
- Wire, screws, etc.

The apparatus should be laid out on the wooden baseboard as shown in Fig. Q. 2280A, so that the grid wires will be as short as possible. The first audio transformer, T1, should be placed on the left side; the input push-pull transformer, T2, at about the middle of the baseboard; and the output choke or transformer, T3, on the right. The tubes should be placed between the transformers. Since there are no controls on this amplifier, it will not be necessary to use a large panel. A narrow insulating strip, containing the eleven binding posts, should be fastened along the front edge of the baseboard. If a cabinet is to be placed over the amplifier, it should be made to cover the front, down to the binding-post strip. When wiring the amplifier, care should be taken to make all contacts tight. The wires used for the A.C. filament circuit should be twisted; so that inductive effects between these wires and the others in the amplifier will be kept at a minimum. These filament wires should also be placed as far away from the other wiring as possible; since an A.C. hum will be noticed in the loud speaker if very much coupling exists between them. The 40-ohm center-tapped resistor is used to obtain an effective center tap of the filaments of the tubes; but it will not be necessary if a center-tapped heating transformer is employed. In this case, the center tap of the transformer is used as the negative "B" and the positive "C" battery terminal.

A number of the manufactured "B" power units are now being equipped with 5-volt filament windings. If a unit of this type is employed, it will not be necessary to use a separate heating transformer for the push-pull tube; for the filaments of the latter will be automatically turned off when the "B" power unit is disconnected from the line.

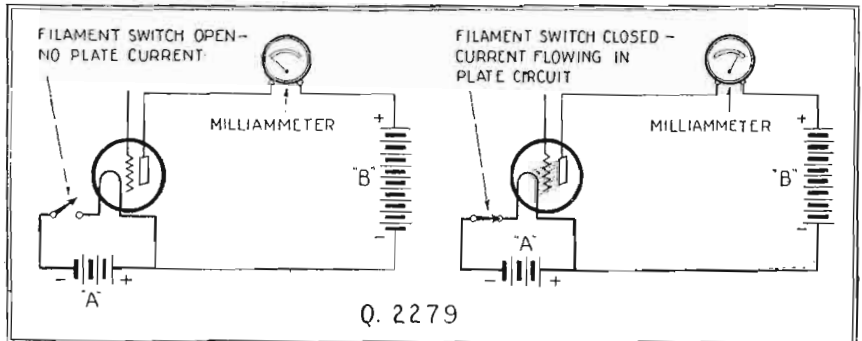

The illustrations above show why it is unnecessary to use a "B" battery switch. As you will see, the plate circuit (which carries the "B" battery current) is incomplete until the filament is heated by the "A" battery, and sends out electrons which provide a path for the current.

Some transformers designed for home assembled "B" power units are also equipped with filament windings, and, for this reason, it is advisable to examine the transformer in your "B" power unit; so that you will know whether this winding has been included or not.

If a separate filament-heating transformer is employed, it will be necessary either to use a separate power switch for turning off the filaments, or to connect the filament transformer primary to the "B" power unit leads, in such a way that the switch in the "B" power unit will also turn off the current to the "A" transformer.

The diagram shows the correct connections for use with an output choke coil. If an output transformer is used, the primary should be connected in the same manner as the choke coil and the loud-speaker connections should be made to the two secondary terminals. When using this amplifier with the set, it should be connected to the detector output or, if extreme volume is desired, it may be connected to the output of one stage of audio-frequency amplification. We would not advise anyone to try connecting the output of an ordinary two-stage amplifier to this unit, as the combination would probably be very unstable and would not operate quietly.

It may be advisable, in some cases, to connect 1-mf. fixed condensers between the "C—" terminals and the "B—" terminal, and also between each of the "B+" terminals and the "B—" terminal.

We would not suggest that the experimenter try to use the ordinary 201A-type tube in the first stage; since this tube has a different type of filament from that of the power tubes mentioned above, and a very strong hum will be noticed if it is used,

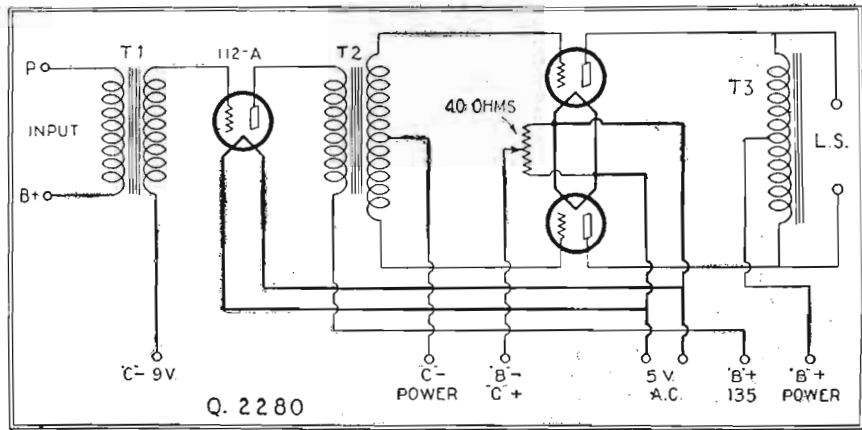

The schematic diagram of an A.C. push-pull amplifier: a first stage of straight transformer coupling is used so that loud-speaker volume can be obtained. The input should be connected to the detector plate and the "B+Det" voltage tap.

REDUCING RADIO-FREQUENCY COUPLING

(2281) Mr. J. R. Baker, Ft. Worth, Texas, writes:

(Q.) "I have noticed that in tuned-radio-frequency receivers, three general positions of the coils are used. In the first the coils are all in the same positions, but are placed some distance apart. In

that their lines of center or axes are at an angle to each other reduces the coupling. When the axes of the coils are exactly 90 degrees apart, or at right angles, this coupling is minimum for the particular distance they are separated. This is one effective method of reducing the feed-back between coils.

There is another method of reducing magnetic feed-back of this kind. If two coils are placed parallel to each other, the magnetic field of one will pass through the other. Whenever magnetic lines of force cut one side of the turns of wire on a coil, and do not cut through with equal strength the opposite sides of the same turns, they set up a voltage difference across the turns. However, if all of the lines of force which cut through one side of a coil also cut through the other side, then equal and opposite voltages are induced in the two sides of the same turns of wire. These voltages balance out each other, so no undesirable transfer of energy is made.

Still keeping the center lines of the coils parallel, but changing the angle they make to a straight line drawn through both of them, causes more and more of the magnetic lines of force sent out by one coil to cut through both sides of the turns of the other. This angle or degree of inclination may be increased until a point is reached at which all of the lines of force cutting through one side of the coil will also cut evenly through the other side. In this particular position, there will be minimum magnetic coupling between the coils. The exact angle for this minimum coupling position varies with the coil diameter and coil length. It has often been stated that the proper angle is 54 degrees and 57 minutes, because in many factory-made neutrodyne receivers this particular angle is used. To determine the proper angle for any receiver, the quickest and most practical method is to try various coil inclinations while the set is in actual operation.

When two coils are placed parallel to each other and only a short distance apart (four to six inches), the efficiency of the coils and their associated circuits must be reduced to such an extent that the feed-back will not cause oscillation.

A NEW T.R.F. RECEIVER

(2282) Mr. J. R. Wilson, Portland, Oregon, writes:

(Q.) "I have recently read about a system which is used for increasing the efficiency on the higher wavelengths, of tuned-radio-frequency receivers employing the phasatrol balancing method. These compensating units work very well, except that a lack of sensitivity is noticed on the upper end of the condenser scales. The system that I refer to uses a small coil across the condenser in the unit. Can you supply any data on this subject?"

(A.) A system which was recently suggested for this purpose by several radio engineers, and which has been tried in the Rantow News Laboratories, is shown in Fig. Q. 2282. In this unit small R.F. coils, L4 and L5, are shunted across the phase-shifting condenser. This coil serves to increase the feed-back at the wavelengths to which it is tuned and naturally increases the radio-frequency amplification on this wave. In this particular case, the coils are wound with about 40 turns of No. 30 D.C.C. wire on a 3/4-inch tube. These coils, in conjunction with the .002-mf. condensers, C4 and C5, are tuned to a wavelength near the upper end of the band; since this is the point at which the loss of efficiency usually occurs. Because the coils are tuned more or less sharply, the operation of the set on the lower wavelengths is not affected.

(Continued on page 1391)

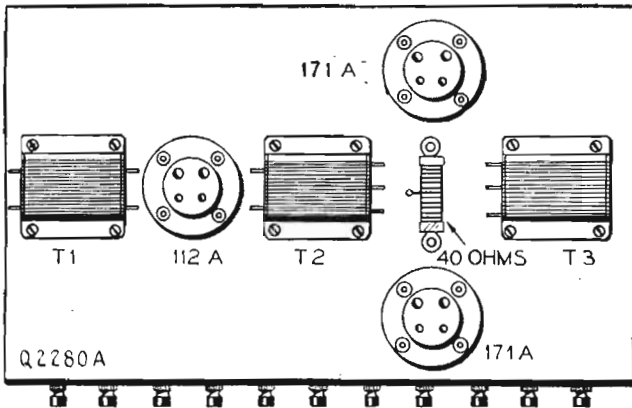

The layout of the apparatus for the above push-pull amplifier is shown here. Since there are no variable controls on this amplifier, it is not necessary to have a complete front panel; a narrow strip is used to hold the binding posts. The 40-ohm resistor is unnecessary if a center-tapped 5-volt winding is used to supply filament current from the tubes of the amplifier. The filament wires should be twisted, and kept away as far as possible from other wiring.

If the detector tube does not already have a bypass condenser connected between the plate and "B—" battery terminal (or the plate and "A—" battery terminal) a condenser of about .002-mf. capacity should be connected across the two input terminals to the amplifier.

An amplifier of this type will give very good results, both for quality and volume. It is necessary, however, to use both the correct "B" and "C" voltages, especially in the second stage; since the quality will be affected considerably if these values are not correct.

the second, the coils are placed at right angles; and in the third they are at a critical angle of about 57 degrees. Can you explain why these three methods are employed, and the advantages of each?"

(A.) It is well known that their magnetic fields will couple together two coils of the solenoid type, unless they are a considerable distance apart. When two such coils have their axes directly in line, the degree of coupling depends upon their separation; the closer the coils, the greater the coupling effect, and vice versa. If the separation between the two coils remains at a fixed value, turning them so

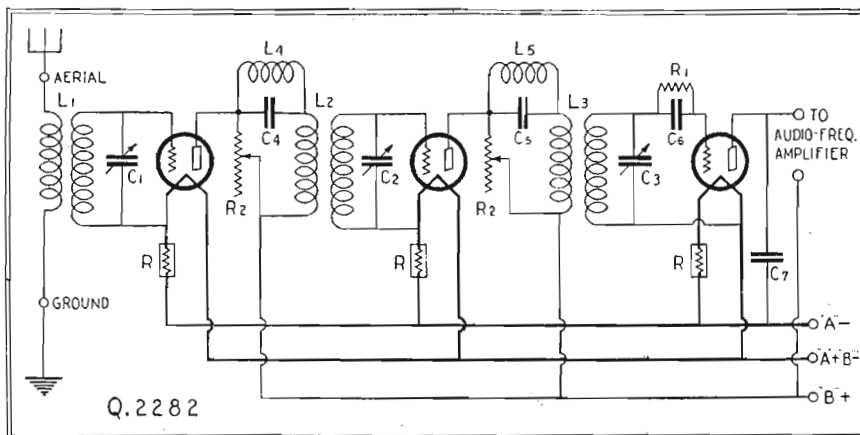

This is an unusual radio-frequency circuit which gives comparatively even amplification over the entire broadcast band; the small coils, L4 and L5, are used for increasing the amplification on the longer waves.

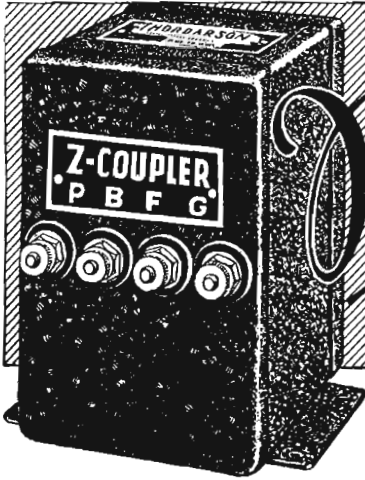

*The Thordarson Z-Coupler, a special audio impedance coupler for use with screen grid tubes; price each, \$12.*

# New! SCREEN-GRID Audio Amplification

Screen grid audio amplification, most revolutionary development in audio systems since the introduction of the power tube, is now an established fact.

The Thordarson Z-Coupler is a special audio coupling device designed for use with the screen grid tube UX-222.

With the remarkable amplification thus obtained a mere whisper from the detector is stepped up to a point that gives the power tube all it can handle in the way of signal voltage. In fact, one stage Z-Coupled audio has the amplification equivalent of two, or even three, stages of ordinary coupling. Signals barely audible before may now be heard at normal room volume.

In tone quality, too, the Z-Coupler is unexcelled. Despite the high amplification the tonal reproduction is as nearly perfect as any audio amplifier yet developed. Both high and low notes come through with the same volume increase. Even at 60 cycles the amplification is over 95% of maximum.

Regardless of the type of your receiver you can vastly improve its performance by including this new system of amplification. The Z-Coupler replaces the second audio transformer, with very few changes in the wiring. The screen grid tube is used in the first audio stage. No shielding is required.

## THORDARSON Z-COUPLER

**THORDARSON ELECTRIC MANUFACTURING CO.**  
*Transformer Specialists Since 1895*  
 WORLD'S OLDEST AND LARGEST EXCLUSIVE TRANSFORMER MAKERS  
 Huron and Kingsbury Streets - Chicago, Ill. U.S.A.

*Write To-Day for Complete Information*

THORDARSON ELECTRIC MFG. CO.  
 Huron and Kingsbury Sts., Chicago, Ill.  
 Gentlemen:

Without obligation on my part, please send me complete information on screen grid audio amplifiers using your new Z-Coupler. (8578-L)

Name .....

Street and No. ....

Town ..... State .....

# Did You Get Your Copy?

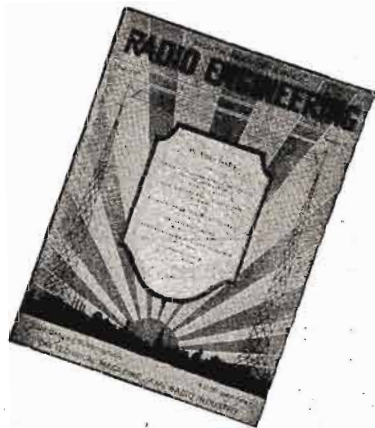

**IF** you are a professional radio man, an engineer, dealer, or technician—

**IF** you do not already subscribe to *Radio Engineering*—

USE THE COUPON BELOW

**HERE IS THE TABLE OF CONTENTS OF THE LAST ISSUE:**

- Theory and Construction of Quartz Crystal High Frequency Oscillators—By Jennings B. Dow Lieutenant, U. S. Navy.
- Filter Circuits for Filament Type Rectifiers—By R. M. Wise.
- The Problem of Radio Set Power Supply, Part III—By George B. Crouse.
- The Problem of the Battery Set, Part II—By Victor Greiff, E. E.
- Small Power Transformers for "A" and "B" Units—By P. McK. Deelev.
- The Mathematics of Radio, Part IV—By John F. Rider, Associate Editor.
- Tuning the Broadcast Transmitter Aerial—By H. R. Rawson.
- The Synchronometer—By H. W. Lamson.
- A Slide-Wire Bridge for the Laboratory—By W. A. Dickson.
- Manufacturing Processes—By F. C. Trimble.
- A Universal Tester—By Leon L. Adelman.

**Departments**

- Constructional Developments of the Month
- News of the Industry
- New Developments of the Month
- Buyers' Directory

**RADIO ENGINEERING IS NOT SOLD ON NEWSSTANDS**

RADIO ENGINEERING, Inc.,  
52 Vanderbilt Ave., New York, N. Y.

Enclosed find \$2.00 for 1 year  
\$3.00 for 2 years  
subscription to **RADIO ENGINEERING**.  
Enclosed find twenty cents (20c.), for which send sample copy of **RADIO ENGINEERING**.

Name.....

Address.....

Town and State.....

Please Check Your Classification:

- Dealer  Manufacturer  Service Man
- Engineer  Professional Set Builder
- Distributor  Anything Else

# Applying Ohm's Law to Radio Apparatus

(Continued from page 1349)

current of 0.75-ampere is flowing, is equal to the resistance of the tube filaments plus the resistance of R2. (R1 is not part of the total resistance under these conditions, as it is cut entirely out of the circuit when the current is at its maximum.) Therefore, as both the total resistance and the resistance of the tube filaments are known, it is possible to find the required value of R2 by subtracting the resistance of the tube filaments from the total; the proper value is 8 ohms minus 6.6 ohms, or 1.4 ohms.

**THE RHEOSTAT**

After the value of R2 has been learned, it is possible to compute the value of R1. This is a variable resistor, or rheostat, which is used to vary the filament voltage to control volume in the set; and, in most cases, a unit which makes it possible to vary the potential across the tube filament terminals between 3 to 5 volts answers all requirements. When working on this basis, it is first necessary to learn the current passing through the filaments of the tubes when the minimum terminal voltage of 3 is applied. By using formula (2) and substituting 3 volts for E and 6.6 ohms for R, the minimum current is found to be equal to 3 divided by 6.6, or approximately 0.47-ampere. Next, it is necessary to find the resistance of the entire circuit when a current of 0.47-ampere is flowing. Formula (3) is used for this purpose and, by dividing 6 volts (E) by 0.47-ampere (I), the total resistance is computed to be approximately 15 ohms.

The computations in the above paragraphs show that 8 ohms is the total resistance in the circuit when the rheostat is cut out and the maximum current of 0.75-ampere is flowing, and that the total resistance needed to reduce the current to a minimum of 0.47-ampere is 15 ohms. Therefore, the value of the rheostat R2 should be 15 ohms minus 8 ohms, or 7 ohms. Standard rheostats are not made in this value and because of this fact it is necessary to select the nearest size. The standard sizes closest to this value are 6 and 10 ohms, and either of these may be used with satisfaction.

**POWER UNITS**

Another, and slightly more difficult, problem which the set builder frequently finds it necessary to solve by the use of Ohm's Law is the design of the *voltage-dividing resistor*, or potentiometer, for a "B" socket-power unit. This device determines the various output voltages of a "B" supply unit, and, therefore, it is highly important that it be correctly designed.

The voltage-dividing resistor of a "B" socket-power unit consists of a bank of resistor units connected in series across the two wires which provide the high-voltage supply. Taps are taken from them at various points in order to obtain the desired voltages for operating the detector, the R.F. and the A.F. tubes of the set. Also, provision is sometimes made for obtaining "C" biasing potentials from the same resistor bank.

The design of the voltage-dividing resis-

tor is entirely dependent upon Ohm's Law; the low intermediate voltages are obtained by virtue of the *voltage drops* which take place in the various sections of the resistor. Also, the exact value of the resistor units may be computed from the Ohm's Law formulas in much the same way as in the previous illustration of the filament rheostat.

In designing a voltage-dividing resistor for any receiver, it is first necessary to know the exact voltages and the amount of current which will be required by the receiver which is to be operated from the power unit. This is absolutely necessary; as any change in current will produce a different voltage drop, with the result that the tubes of the receiver will not be operated at their rated voltages.

For an example, this article will describe the design of a voltage-dividing resistor for use in a power unit which is to supply the "B" and "C" potentials to a six-tube receiver employing three stages of tuned R.F. amplification, a detector, one first audio stage and one power audio stage. The three R.F. tubes are of the 201A-type and require a plate potential of 90 volts and a grid potential of 4½ volts; the detector tube is a 201A, requiring a plate voltage of 45 volts; the first A.F. tube is a 201A with 135 volts on the plate and a 9-volt grid bias; and the power tube is a 171 with 180 volts on the plate and 40 volts on the grid. The "B" socket-power unit must be capable of delivering a maximum potential of 220 volts at 50 milliamperes.

The data supplied by the manufacturer indicate that the plate currents required by the various tubes of the set, when operated as described above, are as follows:

	<i>Milliamperes</i>
One 171-type power tube.....	20
One 201A-type A.F. tube.....	3
Three 201A-type R.F. tubes.....	7.5
One 200A-type detector tube.....	1.5
Total current for set.....	32

In addition to the current required by the receiver there is also a waste of current, through the "C"-biasing section of the voltage-dividing resistor (which is necessary in order to secure a drop of 40 volts), and this must be included in the current drain from the power unit. It is desirable to make this drain as large as possible without reducing the total output voltage of the power unit below the required potential; for increasing the current reduces the output resistance of the power-supply circuit and tends to stabilize the output voltages. In this case it is possible to have a surplus or reserve of 15 milliamperes, which is very satisfactory. Therefore, the total current required from the power-supply unit is 47 milliamperes, which corresponds sufficiently to the rating of our unit.

**FIGURING THE RESISTANCES**

The circuit of the voltage-dividing resistor is shown in Fig. 3. The resistor R1 reduces the voltage from 180 to 135 volts, or causes a voltage drop of 45 volts, for the first A.F. tube; and the current passing through this resistor is equal to 47 milliam-



*The Perfected  
Invention of*  
**Dr. J. Harris Rogers**  
*Celebrated War Time  
Naval Radio Consultant*

The eminent scientist, Dr. J. Harris Rogers is known the world over for his research work and successful accomplishments in the line of underground and underwater radio transmission and reception. His invention, the Rogers *Underground Antenna* for reception of waves within the B.C.L. band is, unquestionably, one of the most important radio advancements of the year.

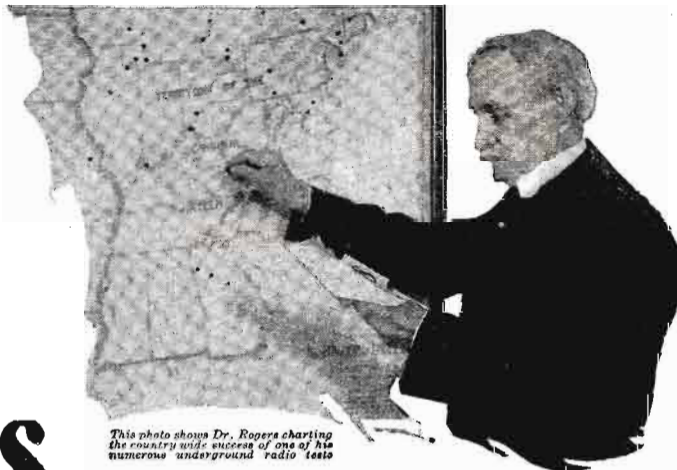

*This photo shows Dr. Rogers charting the country wide success of one of his numerous underground radio tests*

**First news** of the **ROGERS**  
*Underground*  
**ANTENNA**

Made under exclusive license in accordance with patents of Dr. J. Harris Rogers Nos. 1303730, 1349103, 1349101 and pat. pend.

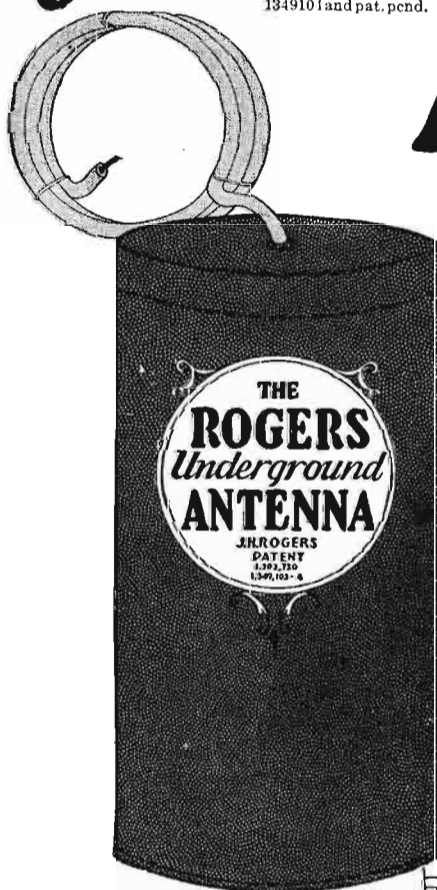

**Provides Clear, Loud Reception  
Regardless of Weather** **Increases  
Distance and Volume with Any Set**

That radio waves, unspoiled by static and less affected by weather conditions, travelled thru the ground was the belief of Dr. J. Harris Rogers. Test after test proved his contention. On nights when weather made reception from distant points impossible with an antenna suspended in the air, reception was clear, steady and loud when taken out of the ground. Static has little effect upon ground-wave reception, and it was found that ground waves usually exceeded the strength of air waves even when the latter were at their best. It then remained for someone to develop a device with which these clear, strong ground waves could be intercepted and brought to the receiving set. Followed more years of research, more experimenting, more practical tests—all resulting in the Rogers Underground Antenna—developed and perfected by Dr. Rogers, himself—the product of a lifetime of study—a proved device, successful wherever used and offered to you with a positive guaranty of money back if you are not satisfied.

**Yours to Test  
FREE**

It costs you nothing to test the Rogers Underground Antenna. We will send it to you to try on your own set, and we don't ask you to pay a cent for this great radio improvement if you don't find it all that *Dr. Rogers claims* in his patents. Send the coupon now. Let us send you the startling facts of the Rogers Underground Antenna and full particulars of the **FREE** comparative test we want you to make. Clip the coupon. Send it today.

**EASILY INSTALLED  
IN 5 MINUTES!**

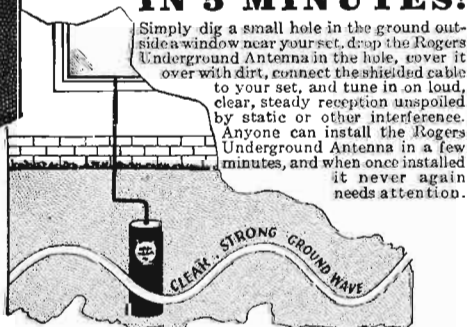

**THE ILLUSTRATION** at the right shows a typical installation of the Rogers Underground Antenna. As there is but little static in the ground, this Rogers unit delivers clear, strong, radio impulses to the receiver, thru the shielded connecting cable. And think! How much easier it is to install the Rogers Underground Antenna than it is to climb around on a slippery roof hanging up a wire which collects as much static as it does radio waves.

**MAIL THIS NOW**

**The Underground Antenna Co.**  
4207 N Cottage Grove Ave.  
Chicago, Ill.

Send me all the facts on the Rogers Underground Antenna. Also full particulars of **FREE** Test Offer and **GUARANTEE**.

Name.....

Street.....

Town..... State.....

**The Underground Antenna Co.**  
4207 N COTTAGE GROVE AVENUE CHICAGO, ILL.



The funniest comic in America, 'Smatter Pop' will keep you in stitches from the moment you open it until you have read and reread every page time and time again. Fifty full-page comics in this edition of 'Smatter Pop'—Hundreds of real laughs. C. M. Payne sure knows how to get under your skin and bring out every laugh in your system.

Meet "Pop," "Desperate Ambrose," and Pop's little family. They can make you laugh when everything else has failed. Ask your newsdealer or, if he can't supply you, fill in the coupon and mail to us. The funniest comic ever written. Don't miss it! Get your copy now! Barrels of FUN!



APLOGIES TO C. M. PAYNE

EXPERIMENTER PUB. CO.  
230 FIFTH AVE.  
NEW YORK CITY

LISSEN---'SMATTER POP IS WHAT I'M  
LOOKING FOR. 'SMATTER POP I SAY! SO  
DONT HOLD ME UP. DONT HOLD ME UP  
MAIL, MY COPY NOW---NOW I SAY---  
HERES MY QUARTER---MY TWENTY-  
FIVE CENTS-----SO RUSH.

NAME.....  
ADDRESS.....  
CITY..... STATE.....

peres minus 20 milliamperes (the current used by the power tube in shunt across R1, 2, 3 and 4) or 27 milliamperes. To find the required value of this resistor, formula (3) of Ohm's Law is used; i. e., the voltage drop (45 volts) is divided by the current passing in the resistor (.027-ampere) and the result is 1,667 ohms. (This is easiest done by multiplying the volts by 1,000 and dividing by the milliamperes; 45,000 divided by 27 equals 1,666-2/3).

The resistor R2 reduces the potential from 135 to 90 volts for the operation of the R.F. tubes. This resistor causes a drop of 45 volts, and the current passing is equal to that in R1 minus the current taken from the "B+135" volt tap; 27 minus 3, or 24 milliamperes. The resistance of this resistor may be learned from formula (3) in the same way and it will be found to be 1,875 ohms.

The resistor R3 causes another drop from 90 to 45 volts in order to reduce the potential to the proper value for the operation of the detector. The current in this resistor is equal to that in R2 minus the current taken from the "B+90" terminal; 24 minus 7.5, or 16.5 milliamperes. Therefore, the resistance of this resistor is equal to 45 volts divided by .0165-ampere, or 2,727 ohms. The resistance of R4 may be computed, in the same way, to be 3,000 ohms.

The resistors R5, R6 and R7 are for obtaining the "C" biasing voltages; and the current passing through each of these resistors is equal to the total current delivered by the power unit, or 47 milliamperes, as no "C" current is drawn by the tubes. Resistors R5 and R6 each produce a voltage drop of 4.5 volts, and R7 produces a drop of 31 volts. By substituting these values it will be found that R5 and R6 each have a resistance of 96 ohms and that R7 has a resistance of 659 ohms.

SELECTION OF RESISTORS

In actual practice, it usually will be found impossible to buy resistors having the exact resistance value required. However, the resistance of each unit need not be exact and the standard resistor having the nearest value may be substituted. For a voltage divider of the design under discussion the following standard resistors should be used: R1, 1,500 ohms; R2, 2,000 ohms; R3, 3,000 ohms; R4, 3,000 ohms; R5, 100 ohms; R6, 100 ohms; R7, 650 ohms. When these resistors are used the output voltages will be found very near the required values.

In the selection of resistors for use in a voltage-dividing resistor bank, the *current-carrying capacity* of each unit must be considered carefully, in addition to its resistance. There is a considerable flow of current through these resistors, and apparatus with an insufficient current-carrying capacity might burn out.

WHAT ARE WATTS

It is customary to rate resistors of the "heavy-duty" type, suitable for use in power circuits, by the number of *watts* they will dissipate. The watt is the electrical unit of energy and is equal to the power consumed (by conversion into heat, etc.) when one ampere of current flows through one ohm of resistance, producing in it a drop in potential of one volt. The number of watts of energy expended in any electrical device may be determined by multiplying the potential across the ends of the ap-

The **ELECTRIC** Radio  
**Freshman**  
**EQUAPHASE**  
at All Authorized Dealers

**C. L. PARKER**  
Ex-Examiner U. S. Patent Office  
Attorney-at-Law and Solicitor of Patents  
McGill Building, Washington, D. C.  
Patent, Trade Mark and Copyright Law

**6 TUBE** Only \$16.95  
**SUPERPHONIC** Radio  
**FREE!** 6 TUBES  
LX-201-A Type  
Tested & Matched  
METAL CHASSIS  
SHIELDED  
COAST to COAST  
RECEPTION  
An amazing value that can't be beat! Latest 6 tube tuned radio frequency circuit. Extremely selective. Send for complete descriptive circular. Value \$60.00, our price \$16.95. Write today.  
RADIO EQUIPMENT CO., 549 S. Wells St., Dept. 12F Chicago

**LIGHTING FIXTURES**  
Ready to Hang  
Direct from the manufacturer. Completely wired, including glassware. Send for new catalogue No. 29. Just Reduced Prices.  
Special Proposition to Dealers.  
Erie Fixture Supply Co., Inc.,  
Station R, Erie, Pa.

Insure your copy reaching you each month. Subscribe to Radio News—\$2.50 a year.  
Experimenter Publishing Co., 230 Fifth Avenue, N. Y. C.

# Don't Take Chances with Condenser Breakdown!

"The man who tries to save a few cents by buying cheap condensers is always in danger of having to pay out many dollars for replacement parts. A cheap condenser is expensive when it breaks down."



*Leslie G. Biles*

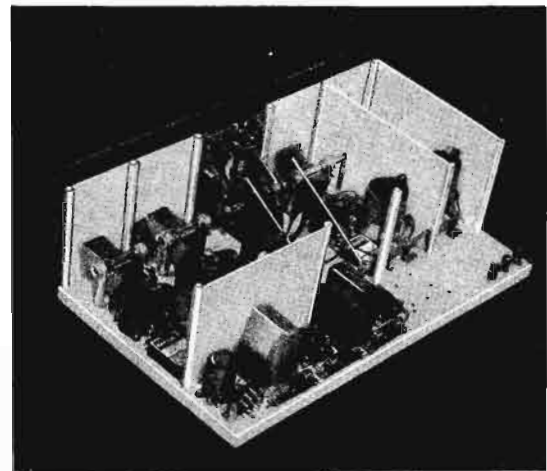

The famous Hammarlund-Roberts, Hi-Q Six employs parts produced by ten of America's finest radio manufacturers, including ACME PARVOLT By-Pass Condensers.

# Play Safe with PARVOLTS!

THE rapidly increasing use of by-pass and filter condensers in modern A. C. operated circuits demands the greatest caution against poor quality, inaccuracy of rating and non-uniformity in condensers.

Nothing can do so much harm to impair radio reception or effect such costly losses in assembled parts as defective or inaccurate condensers.

It is of vital importance to use condensers of proper ratings, and to know the ratings actually ARE as stated and that all stated ratings are UNIFORM.

It is vital to use condensers whose ratings are based upon CONTINUOUS DUTY.

It is vital to use condensers that

are made with AT LEAST the overload factor of safety demanded by the R.M.A. and N.E.M.A.

Condensers which possess these qualities not only aid quality reception, but overcome the possibility of break-down and heavy losses from ruined tubes, transformers and other parts...All ACME

PARVOLT Condensers are made and tested to standards of the R.M.A. and N.E.M.A. They are used and recommended by leading radio engineers, designers, service men and custom-builders everywhere. Play safe with PARVOLTS! Made by THE ACME WIRE CO., New Haven, Conn., manufacturers of magnet and enameled wire, varnished insulations, coil windings, insulated tubing and radio cables.



ACME PARVOLT FILTER CONDENSERS are supplied in all standard mfd. capacities for 200, 400, 600, 800, 1000, and 1500 Volt D. C. requirements. Uniform height and width for easy stacking. Supplied singly or in complete housed blocks for the important power supply units such as Thordarson, Samson and others.

ACME PARVOLT BY-PASS CONDENSERS are supplied in all standard mfd. capacities and for all the required working voltages.

# ACME PARVOLT CONDENSERS

Made by the Manufacturers of

# ACME CELATSITE HOOK-UP WIRE

### ENAMELED AERIAL WIRE

Enameled copper wire in both stranded and solid types. Also Acme Lead-ins, Battery Cables, Indoor and Loop Aerial Wire.

### CELATSITE FLEXIBLE and SOLID

For all types of radio wiring. High insulation value; non-inflammable. 10 colors.

### ACME SPAGHETTI

A superior cambric tubing for all practical radio and other electrical requirements. Supplied in 10 colors.



## AMAZING STORIES AM QUARTERLY

### Big New Spring Edition Just Out

**T**HE greatest issue of AMAZING STORIES QUARTERLY yet published. Scientifiction by the worlds' most famous writers. This big new Spring issue is a book that no one should neglect to read. If you are tired of the cut-and-dried fiction of the day—if you desire to read something different—entirely out of the ordinary—do not miss this remarkable book, the AMAZING STORIES QUARTERLY.

*A few of the interesting stories that you will find in this new issue:*

The Nth Man	The King of the Monkey Men
The Second Swarm	A Modern Atlantis
The Gravity King	When the World Went Mad

Tales of the future, of worlds to come—of different people—of strange happenings. Read this New big issue of the AMAZING STORIES QUARTERLY. Adventure, Mystery, and Science—a touch of each combined to make one of the most remarkable volumes of the age.

*150 pages—fully illustrated—large magazine size*

THE **50c** COPY

AT ALL NEWSSTANDS  
OR WRITE DIRECT

EXPERIMENTER PUB. CO.

230 Fifth Avenue  
New York City, N. Y.

paratus in volts by the current in amperes. Or, as we may put it in another formula:

$$W = E \times I \quad (4)$$

But, as we know by formula (1), the voltage (E) is equal to the product of I and R; and therefore the wattage is equal to the current, multiplied by itself, and by the resistance. This is another and convenient way of stating the same thing as (4):

$$W = I^2 R \quad (5)$$

(The expression "I<sup>2</sup>" is read "I square," and signifies that I (the amperage) is multiplied by itself. If the current is written in milliamperes, its square will represent *millionths*, instead of thousandths, of the square of the amperage.)

Radio engineers speak most frequently of the "I<sup>2</sup>R" loss in discussing power circuits; this term for the wattage represents the dissipation as heat of electrical energy in a resistor. The current-carrying capacity of a resistor is therefore rated in watts, which depend on both voltages and currents. A filament resistor may carry a heavy load through a very small resistance; a grid leak a very light load through an enormous resistance, and neither needs to dissipate many watts.

But the power resistor must be so constructed that it will give off the heat generated in it by the current passing; its rating indicates what may be expected from it under a constant load. The two formulas just above will give the watts of energy converted into heat in any part of a given circuit; a rating above this figure should be employed.

For instance, take R1 in Fig. 3; it has a current of 27 milliamperes passing through it with a potential drop of 45 volts. Multiplying 45 (E) by .027 (I) formula (4), gives 1.215 watts as the *dissipation* of heat which must be obtained from the resistor used. If we use formula (5) we multiply .027 by itself (I<sup>2</sup>) by 1,666-2/3 (R), with exactly the same result.

The caution must be given again to remember that, in the formulas above, I represents amperes, not milliamperes; 1,100 milliamperes is only 1.1 ampere; 110 milliamperes is 0.11-ampere; 11 milliamperes is .011-ampere; and 1.1 milliamperes is expressed as .0011-ampere. This correction must always be borne in mind when working with Ohm's Law in radio design.

Resistors manufactured for use in ordinary resistor banks are designed for 3-, 5- and 10-watt ratings; and in most cases, as will be seen, the 3-watt size will be ample. However, for different radio purposes, resistors are made for duty up to 100 watts, and might be designed for even heavier current dissipation, if needed.

### A Remedy for Obstinate Cases for A. C. Hum

**I**N most cases where a strong hum is heard in the loud speaker of an A.C.-operated set, the trouble may be corrected by improving the filter circuit or the "B" socket-power unit. On the other hand, often it is next to impossible to find the cause of the hum, or a means of preventing it. In sets where it has been found impossible to eliminate hum by ordinary methods a 0.25-mf. condenser connected between the "B—" wire of the power unit and one terminal of the 110-volt A.C. supply line will often effect an improvement. Also, the metal cases of all transformers, choke coils, and condensers of the power unit should be connected with the negative wire.

# Airplane Radio

(Continued from page 1305)

On May 17 the trio left for the Azores. It was a long and hazardous jump. Two days later the NC-4 alighted in Horta Bay. The other two argonauts lost their way in the fog and descended on the water a short distance from the islands. Luckily, they were all saved after an anxious search. Ten days later the NC-4 arrived at Lisbon, Portugal, and finally ended the air cruise at London. Herb Rodd was the NC-4's radio man.

## THE FIRST THROUGH FLIGHT

On June 14, 1919, Captain John Alcock and Lieutenant Arthur W. Brown, in a Vickers-Vimy bomber, flew from Newfoundland to Clifden, Ireland, a distance of 1,980 miles, in sixteen hours and twenty minutes. This was the first non-stop trans-Atlantic airplane flight.

The Vickers-Vimy bombers were designed with a radio direction-finder as part of the equipment. The loop antenna was built into the wings, and the receiver acted as a radio compass. There was no transmitting apparatus. Just before the plane taxied down the runway, someone is said to have asked Alcock where he expected to land. He is reported to have replied that they would "hang our hats on the Clifden wireless towers." The plane ran down the field and was soon a mere speck out over the misty sea. Then it vanished! The world awaited anxiously for news from the airmen. The ether was silent. No vessel reported sighting the plane. But, at the end of seventeen hours, word was rushed around the world that the Atlantic had been crossed for the first time by a non-stop airplane. How much the navigators depended upon the radio direction-finder is not recorded in the story of the flight, but it is believed that it was the guiding influence of radio that enabled the plane to fly directly over the Clifden radio towers; in fact, it just missed disaster by striking them, and landed in the mud a short distance back of the station.

A month before Alcock and Brown triumphed, Harry Hawker, an Englishman, accompanied by Lieutenant Commander Mackenzie Grieve as navigator, hopped off from St. Johns, Newfoundland, for Ireland in a Sopwith biplane. Hawker dropped his undercarriage and wheels, to save weight, immediately after the plane was over the sea. His original plans called for radio equipment, but he discarded it to lighten the craft at the last minute. Nothing was heard of Hawker and Grieve for more than a week. They were given up for lost. Memorial services were held in London. It was then reported from the Orkneys that the Danish steamer *Mary* had rescued the aviators about 1,050 miles out from Newfoundland, and about 850 miles off the Irish coast. The *Mary* was not equipped with radio.

How different was the case of Ruth Elder and George Haldeman, as they dropped alongside the Dutch oil steamer *Barendrecht* off the Azores on October 13, 1927, when their oil system forced the plane "American Girl" to leave the air. While the airplane carried a radio, it was not efficiently used. The world wondered if they

# LEUTZ CUSTOM BUILT RADIO



Custom Built Universal Transoceanic "Silver Ghost" Broadcast Receiver Built for Robert B. Gable, President Wm. F. Gable Co., Altoona, Pa.

The LEUTZ organization is now entering its sixth successful year of supplying the Highest Class Radio Apparatus in the World. This year each set is being

custom built to the particular requirements of each customer. We would be pleased to give you an estimate on the best radio for your requirements.

WRITE FOR NEW LITERATURE NOW

## C. R. LEUTZ, INC.

195 PARK PLACE - - ASTORIA - - NEW YORK

Cables: "Experinfo," N. Y.

Phones: Ravenswood 4080-3670

**\$75 to \$125 Weekly**

**Charging Batteries Starts You**

Let me show you how to make big money right from the start. I've prepared a FREE book explaining all details. First week's profit pays for all equipment. You can get all the battery charging business in your community with my Service Station Charger—it's years ahead of ordinary chargers—handles 50% to 70% more batteries. I explain everything—start you in a business of your own and put you on the way to big money. Write for FREE BOOK.

C. F. HOLMES, Chief Engineer, Dept. R.N.  
Independent Electric Works  
5116 Ravenswood Ave. Chicago, Ill.

**FREE BOOK—Just Out**



## "CHI-RAD"

Recommends—

Madison-Moore Super—  
Nine-in-Line Super  
Remler 115 KC Super  
and the Tyrman 70

Complete parts in stock. Dealers and set builders write for discounts.

### NEW SHORT-WAVE COILS

Specially built by "Chi-Rad." Write for descriptive bulletin and catalog. Dealers and set builders: please use business letterhead when writing for discounts.

Chicago Radio Apparatus Co.  
415 S. Dearborn St., Dept. RN, Chicago

# 8 POPULAR MODERN MOVIE NOVELS \$1.00

## GREATEST OFFER EVER MADE

### Take Advantage of This Amazing Bargain

Eight full size books for one dollar. Never before has an offer of this kind been made. Only quantity production permits us to make this astounding offer now. Take advantage of it while you have the opportunity. Needless to say these modern up-to-date movie hits cannot last long at this tremendous bargain price. Each book contains at least two color "stills" of an actual scene from the photoplay. Don't hesitate. Mail this coupon now. Every story based on an actual moving picture triumph. The greatest book bargain of the age.

### Titles of This Tremendous Bargain Offer

1. New York
2. The Campus Flirt
3. Almost a Lady
10. Sensation Seekers
11. The Rambling Rangers
12. Don't Tell the Wife
14. Tracked by the Police
15. Tell It to the Marines
19. Irresistible Lovers
20. The Cohens and Kellys In Paris
21. The Divine Woman
22. Jazz Mad
23. The Crimson City
24. You Can't Beat the Law
25. Tillie's Punctured Romance
26. Forbidden Hours

8 BOOKS FOR \$1.00  
Your Choice

### An Addition To Your Library

These books will be a worthwhile addition to your library. You will find many hours of truly enjoyable reading in each beautiful volume. Printed on fine paper with large clear type. Beautiful colored covers of flexible durable material. These books are undoubtedly one of the greatest values ever offered at this amazingly low price.

Write Now! Don't Wait! This bargain cannot last long at this price

CONSRAD COMPANY, INC.

230 FIFTH AVENUE

NEW YORK, N. Y.

CONSRAD COMPANY, INC., 230 Fifth Avenue, New York, N. Y.

Gentlemen: Enclosed find \$1.00. Kindly send me the books listed by number herewith:

Numbers.....

Name.....

Address.....

City..... State.....

### RADIO PANELS BAKELITE—HARD RUBBER

Cut, drilled, and engraved to order. Send rough sketch for estimate. Our Complete Catalog on Panels, Tubes and Rods—all of genuine Bakelite or Hard Rubber—mailed on request.

STARRETT MFG. CO.  
520 S. GREEN STREET - - CHICAGO

### VICTOREEN

Super Coils

Send for Folder and our Blue Print of the new A. C. circuit.

Geo. W. Walker Co.  
2825 Chester Avenue  
Dept. B Cleveland, Ohio



### 6-TUBE RADIO COMPLETE \$34.75 to \$66.66

Licensed R.C.A. Circuits. Shielded. One Dial  
Write for catalog. Big discounts to agents  
Consumers Radio Co., Dep. 145, 4721 Lincoln Av. Chicago

### SEND FOR FREE CATALOG

From Chicago's Oldest Radio Jobbers. The most valuable Radio Catalog. Write for your copy today—IT'S FREE!  
TELEPHONE MAINTENANCE CO.  
123-5 S. Wells St., Dept. 78 Chicago, Ill.

# Balkite Radio

### ARE YOU SELF-CONSCIOUS? DO YOU STAMMER?

You must overcome Self-Consciousness—Mental Fear—Bashfulness to succeed in the business and social world. Send for amazing booklet, "Road to Poise and Achievement." Tells how thousands have conquered Self-Consciousness in a very short time.  
SEYMOUR INSTITUTE, 38 Park Row, Dept. 136, New York City

had met the fate of many other trans-Atlantic fliers. The rescue ship flashed the good news that the fliers were safe!—as told by its operator in a letter to RADIO NEWS (page 800, January, 1928).

### NINE YEARS AGO

Let us return to 1919 to pick up the story again at that point. Late in June of that memorable year in aviation, the British dirigible R-34 flew from Scotland to Long Island and then returned to Pulham, England, piloted by Major G. H. Scott. The R-34 was equipped with a vacuum-tube transmitter. When it was yet off Cape Race, Newfoundland, the signals were first detected in the United States. When over the Bay of Fundy, the operator sent an urgent message that the fuel supply was running low and a forced landing at sea might be necessary. The message was picked up at Otter Cliffs, Maine. A "sub-chaser" was loaded hurriedly with fuel and dispatched at full speed to about 100 miles off Bar Harbor to meet the dirigible. As the big craft sailed above the tiny sub-chaser dancing in the heavy sea, the radio man signaled that they could reach Chatham Air Station and possibly Mineola Flying Field, which they succeeded in doing.

In 1924 the U. S. Army Air Service round-the-world planes crossed the Atlantic by way of Greenland. They did not use radio. However, Leigh Wade, one of the round-the-world fliers, in commenting upon the Nungesser flight, said that he would not attempt the trip without radio, as did the Frenchman. He called attention to the fact that safety to a great degree depends upon the precautionary measures taken at the start.

It was also in 1924 that the big Zeppelin ZR-3, later renamed *Los Angeles*, flew across the sea from Friedrichshaven, Germany, to Lakehurst, N. J. This flight revealed that radio is an asset on a trans-oceanic trip, even when the ship is not in trouble. The giant of the air maintained communication with European land stations, with vessels at sea, and soon after it passed mid-ocean, the American coastal stations intercepted its messages broadcast from the sky. It was a radio dispatch flashed across the sea by a high-power transmitter that relieved anxiety throughout Germany with the news, "She has landed!"

There is no record that Commander Ramon Franco in his flight in 1926 from Palos, Spain, to Argentina used radio; nor did Commander de Pinedo in his trans-Atlantic flight in February, 1927, from Italy to Brazil. Nor were the invisible waves called upon to serve the French fliers, Lieutenant Dieudonne Costes and Lieutenant Comander Joseph Lebrun, who flew 23,000 miles to reach New York by way of Africa and South America.

### OUT OF THE POLAR SEA

Commander Richard E. Byrd carried a short-wave transmitter, operating on the 44-meter wave, when he dashed to the North Pole and back to his base at Spitzbergen in 1926. His signals were received from the Pole itself.

Was it not radio that kept an over-anxious world informed of the *America's* progress and of her plight, lost in the fog over France? Had it not been for radio on board the big Fokker, no one would have known that the plane with its four occupants was groping in the darkness and

storm with gasoline supply fast becoming exhausted. Radio gave some indication of the plane's position, while silence might have led many to believe that the *America* had joined the other pioneers of the air that "went down to the sea."

The *Norge*, with Roald Amundsen and his associates on board, found radio extremely useful, and especially the radio direction-finder, when the dirigible was lost in the arctic wastes after it had passed over the North Pole in 1926. Radio waves sent out from Alaska served as a beacon for the pilots.

The question has arisen, whether or not short-wave apparatus or long-wave equipment is best for an airplane. Short waves require less power to span long distances, but they are likely to skip over the immediate vicinity where bandy rescue ships might be called upon. The "SOS" from the *Dallas Spirit* over the Pacific was picked up in New York City on the 33-meter wave. When Marconi's attention was called to this remarkable transmission, he said: "That is all right from a news point of view, but help could not be sent from New York to a plane near Hawaii. A 600-meter signal that might have been picked up by a nearby ship would have been more practical."

Previous to 1912, it was not required by law that all trans-Atlantic vessels should carry radio. But when the value of wireless was realized, especially after the *Titanic* disaster, all ships were ordered to carry radio. It is believed that before many years pass American airplanes will be forced by law to carry radio installations, as are French passenger planes today. A plane in distress at sea without radio is like a voiceless man drowning in the dark, who can hear rescuers groping for him, but cannot call to them.

## Reception Acoustics

(Continued from page 1311)

Finally, the tonal efficiency of many older speakers—both cone and horn—is materially affected by damp weather. This is due to the fact that, because of its not being impregnated, the paper of which they are made absorbs moisture from the air, thereby causing a deadness in the output. The only remedy short of replacement is to exclude moisture from the room as much as possible, and keep the speaker warm.

From all the foregoing suggestions, it should be clear that, at the receiving end, acoustics plays a part nearly as important—though generally overlooked—in the attainment of tonal fidelity as it does in the studio. The suggestions offered entail little trouble or expense and, when put into practice, should round out the efforts of transmission engineers and receiver designers in a gratifying way.

## Handle Tubes Carefully

WHEN handling radio tubes, be careful not to jar them violently. There is little danger of breaking the filament, but the elements are likely to be sprung slightly out of position by the shock, and their operating characteristics will then be seriously impaired.

# Carefree Reception

A.C.-D.C.  
Any Cycle

Delivers up to 100 volts on any set. Full tone, clarity, volume, distance.

## Performance That Amazes At This Startling Low Price

Why put up with muffled, uneven, interrupted battery reception another day when you can equal the best tone, clarity, and volume also get the added thrill of good long-distance reception for only \$6.85? Frank H. Webber, of Cazenovia, N. Y., writes: "I have tried several high-priced Eliminators and they do not equal the TOWNSEND. It is better than you claim, and I have no trouble in getting the Pacific coast on my five-tube Neutrodyne." D. J. Mills, of Gonzales, Cal., writes: "I have received Japan and Australia using your Eliminator." Convenient, dependable as your electric light. Just plug into light socket and forget it.

**SEND ONLY \$1.00**

Simply fill out coupon and slip it into an envelope with only \$1.00 and mail at once. Your Townsend "B" Socket Power Unit will be sent promptly. Deposit only \$5.85 plus postage with the postman. Try out 10 days—then if not more than pleased return it, and purchase price will be refunded.

## TOWNSEND LABORATORIES

713 TOWNSEND ST. (DEPT. 25)  
CHICAGO, ILL.

MONEY BACK  
GUARANTEE

### Approved

and passed by the  
rigid laboratory  
tests of Popular  
Radio and Radio  
News

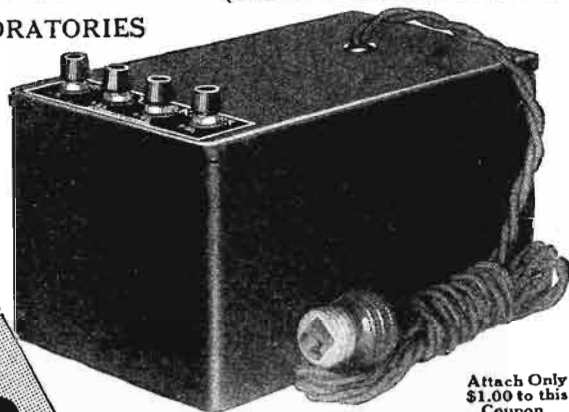

Attach Only  
\$1.00 to this  
Coupon

Complete  
**\$6.85**  
\$1.00 Down  
Balance C.O.D.  
10 Days' FREE TRIAL  
Send for Literature

**TOWNSEND LABORATORIES**  
713 Townsend St., Dept. 25 Chicago, Ill.  
Gentlemen: Attached find \$1.00. Kindly send at once Townsend "B" Socket Power Unit, C.O.D. for \$5.85, plus postage, on guaranteed 10-day free trial.

Name .....  
Address .....  
City ..... State .....

## DUPLEX CLAROSTAT

REG. U. S. PAT. OFFICE

Send for latest copy of "Multiple Micrometric Resistance" Folder. American Mechanical Laboratories, Inc., 285 North Sixth Street, Brooklyn, N. Y.

Write for descriptive circulars on Electrad specialized controls.  
Dept. A-6, 175 Varick St., New York City, N. Y.

## ELECTRAD

**EVERYTHING IN RADIO**  
AT ATTRACTIVE PRICES. SETS OR PARTS.  
Orders shipped exactly as ordered. Prompt Service.  
Write for Prices. Mail Order Only. Send Your Address.  
ALL RADIO COMPANY, 417 North Clark St., Chicago

## Send for Free Catalog Airplane Cloth Speaker

Also contains many bargains in all types of Cone Speakers, Units, complete parts to build all types of cone speakers. Also the latest parts of the New AIRPLANE Cone Speaker. Accessories.  
ACCUSTI-CONE, 1 No. 7th St., Phila., Pa.

## SET BUILDERS BIG DISCOUNTS

Big New 1928 Catalog — Shows latest A-C circuits, newest ideas, 4000 leader. Get sets and parts you want here. Save money. Parts, kits, complete factory-built sets, supplies. Quick service. Write for free copy. Standard discounts to dealers, set builders, agents. Barawik Co., 129 N. Jefferson St., Dept. 806, Chicago, USA.



**TOBE** CONDENSERS and VERITAS RESISTORS  
Stand up on their Jobs  
Tobe Deutschmann Co., Cambridge, Mass.

# CUSTOM SETBUILDERS

## A FREE SERVICE IN THE

### RADIO LISTENERS' GUIDE and CALL BOOK

The RADIO LISTENERS' GUIDE and CALL BOOK has instituted a new service, the purpose of which is to increase the volume of sales on custom-built sets. To this end, we have left no stone unturned in our efforts to cooperate with the home setbuilders. The Spring issue of the RADIO LISTENERS' GUIDE and CALL BOOK carried the first of a series of articles on this ever-widening group of Custom or Community Setbuilders, as they are sometimes known. Reproduced herewith is our offer to these setbuilders to make use of the services of our magazine in increasing their sales. We have set aside a section in which we will advertise the product of every setbuilder who desires to avail himself of this service. These ads will be keyed and listed geographically, and will cost the custom setbuilder nothing. The only requirements that must be met in order for anyone to make use of this section are, first, that the advertisement contain no more than fifty words, secondly, that it be written on a piece of white paper and attached to the coupon provided for this purpose in either the Spring or the Summer issue of RADIO LISTENERS' GUIDE and CALL BOOK.

## A NEW SERVICE FOR THE CUSTOM-SETBUILDER

This issue marks the inauguration of a new service to our readers who are building radio sets.

In the next issue of RADIO LISTENERS' GUIDE and CALL BOOK, we will print a page called

### THE RADIO SET MARKET

in which every reader who is making radio sets for sale, can place his offer before the public *without cost*.

No. 655—Setbuilder in Los Angeles, Cal., has 5 tube Heaters-Mission sets for sale. Specializes in this kind of set. Can build any make of set to order. Write.

This is the way each offer will be listed; and any inquiry referring to the code number under which your offer is listed, will be forwarded to you immediately—*without cost*.

We believe this service will be a great boon to the custom-setbuilder.

It will open a national market—help dispose of more sets—and make more money for you.

Besides opening our columns to our readers for this purpose, we have made this service absolutely free and with conditions easy enough for all to live up to;

### CONDITIONS

Not more than fifty words to each advertisement. Each request must be written on a separate sheet of paper, to which the coupon appearing below *must be attached*. No request will be considered without coupon.

RADIO LISTENERS' GUIDE  
AND CALL BOOK,  
230 Fifth Avenue,  
New York City.

Gentlemen:

Without cost or obligation  
to me, kindly insert the at-  
tached Custom-Made offer  
in your next issue.

Name .....

Address .....

City .. State .....

RADIO LISTENERS' GUIDE & CALL BOOK  
230 5th Ave., N. Y. C.

Everything that is of interest to the Custom Setbuilder can be found within the pages of RADIO LISTENERS' GUIDE and CALL BOOK. There is a complete log of Radio Broadcast Stations, revised and brought up to date quarterly, also every worthwhile circuit and each new development in the Radio world is fully reviewed and unbiasedly treated in the pages of this magazine.

Do not neglect to take advantage of the service we offer you. REMEMBER IT IS YOURS AT NO COST. Read more about this amazing offer in the Summer Issue of RADIO LISTENERS' GUIDE and CALL BOOK.

Each issue contains over 196 pages of interesting, valuable information. Replete with circuits and circuit diagrams. Large magazine size.

THE 50c COPY

AT ALL NEWSSTANDS, OR WRITE DIRECT TO

CONSRAD CO., INC., 230 Fifth Ave., New York, N. Y.

## The Radio Beginner

(Continued from page 1335)

- Two audio-frequency transformers, 3:1 ratio, T1, T2;
- One output choke coil, 30-henry, CH;
- One by-pass fixed condenser, 1-mf., 180-volt rating, C;
- Two vacuum-tube sockets, UX-type, V1, V2;
- One filament-ballast resistor for 201A-type tube, R1;
- One filament-ballast resistor for 112A-type tube, R2;
- One single-circuit telephone jack, J;
- One 201A-type vacuum tube for V1;
- One 112A-type vacuum tube for V2;
- Two 4½-volt "C" batteries;
- One wooden baseboard, 17 x 4 x ½-inch;
- One sheet of copper or brass, 10 x 3½-inch, about 1/32-inch thick;
- Ten feet insulated wire, No. 18;
- Four rubber-headed tacks.

## The How and Why of Radio Filters

(Continued from page 1346)

### BEFORE THE A.F. AMPLIFIER

A third important use of the R.F. choke coil is to prevent R.F. currents from entering A.F. circuits. There are many types of audio-frequency amplifiers which will amplify R.F. currents as well as A.F. currents; and, if the former were allowed to enter the audio amplifier, the utility of that device would be greatly reduced because the R.F. currents would overload the tubes, and thus prevent the efficient amplification of the A.F. impulses. All A.F. amplifiers will amplify R.F. currents, to some extent; but this is true particularly of resistance- and impedance-coupled amplifiers.

R.F. currents are most apt to enter the audio amplifier through the primary of the first A.F. transformer or the first coupling device, which is connected in the plate circuit of the detector tube; because a detector always transmits some R.F. impulses. Therefore, a choke coil and by-pass condenser should always be connected in the detector circuit, in such a way that the R.F. currents cannot pass through the primary winding of the transformer. The way in which this is accomplished is illus-

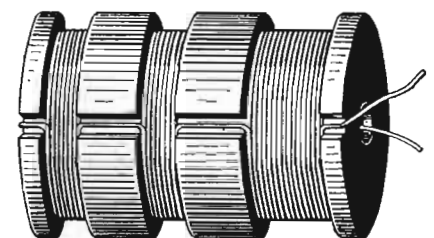

Typical example of the construction of R.F. choke coils, such as illustrated on page 1344 (center of the heading); the windings are separated to reduce self-capacity.



trated clearly in Fig. 4. The R.F. choke coil is connected in series with the lead to the A.F. transformer from the tickler coil or plate of the detector; and the by-pass condenser is connected between the plate side of the R.F. choke coil and the filament. Consequently, the D.C. and the A.F. components of the current in the plate circuit of the tube pass from the plate through the primary of the A.F. transformer; while the R.F. component is blocked by the choke coil and is forced to return to the filament through the by-pass condenser. The same circuit is used, whether or not a tickler coil is employed.

The use of a choke coil in the position shown in Fig. 4 has an especial advantage when the amplifier is connected externally to the receiver cabinet. With an R.F. choke coil in the plate circuit the R.F. current is shunted directly to the filament, and only audio current is fed to the amplifier. The wires connecting the set with the amplifier may then be as long as required, without affecting the results obtained.

The more important uses of R.F. chokes and R.F. by-pass condensers have now been considered; but there are many other places in which these parts are sometimes required in radio circuits. For example, by-pass condensers are always connected in shunt with any instrument which introduces straight ohmic or pure resistance into a tuned circuit, as in this way it is possible to reduce the total resistance (the impedance) of the unit to R.F. currents. In reflex circuits, condensers are connected across the windings of A.F. transformers; and in other circuits, similar condensers are connected across potentiometers, grid-bias resistors and other apparatus which is sometimes connected in the grid circuit, to protect them from R.F. currents.

USE OF A.F. CHOKES

In audio-frequency circuits choke coils are used just as much as in R.F. circuits, and are employed in much the same way. In "impedance"- (capacity-) coupled amplifiers, chokes are required actually to prevent coupling; in socket-power units they are employed to smooth out or to filter out the "ripples" of the rectified alternating current. In other places they serve to separate the D.C. from the audio-frequency components of the current in a circuit, as in output filters.

A very important use of the A.F. choke coil is in the plate-supply wires of an audio-frequency amplifier. When connected in this position it prevents the interstage coup-

# Radio Retailers & Wholesalers

are cordially invited to meet us at the

## Second Annual Trade Show

BOOTH NO. 107, EXHIBITION HALL

### Stevens Hotel, Chicago

### June 11th to 15th inclusive



Ask Our Representative  
about the New CeCo

# Shielded Grid A. C. Tube

Have you tried the new

## Power Output Amplifier CeCo L-50



This new addition to the "CeCo" tube family is designed to provide a greater loud speaker volume, without distortion, than has heretofore been possible, especially in conjunction with auditorium loud speakers and in the operation of a plurality of loud speakers from a common amplifier as in hospital and exposition work.

Fil. Volts ..... 7.5  
Fil. Amp. .... 1.25  
Plate Volts ..... 450 Max.

LIST PRICE—\$12.00

C. E. MANUFACTURING CO., INC.  
PROVIDENCE, R. I., U. S. A.

**Station**  
**WRNY**  
NEW YORK  
326 METERS — 920 KILOCYCLES  
and 2XAL, 30.91 METERS

*is owned and operated by the  
publishers of this magazine  
Our Editors will talk to you  
several times every week—  
See your Newspaper  
for details  
TUNE IN ON  
WRNY*

**BIG  
New SUMMER  
RADIO CATALOGUE**

DEALERS—SET  
BUILDERS—AGENTS

Write for this Catalogue, New  
Summer and Fall Book. Save money  
on newest booklets, sets, kits, parts,  
accessories at lowest prices.

The "Big, Friendly Radio House"  
WESTERN RADIO MANUFACTURING CO.  
126 West Lake Street, Dept. 16, Chicago, Illinois

The **AEROVOX**  
"Research Worker"

is a free monthly folder that will keep you abreast of the  
latest developments in Radio.

Your name will be placed on the mailing list on request.

AEROVOX WIRELESS CORP.  
68 Washington St. Brooklyn, N. Y.

**TOWER** RADIO  
ON SALE EVERYWHERE PRODUCTS

**SCOTT WORLD'S RECORD  
SUPER 10**

Build the 9-100-mite  
receiver. Listen in on  
all the world. Easy  
and economical to con-  
struct. Results guaranteed. Write today for  
free circuit diagram, parts list and copies of long  
distance reception verifications.

SCOTT TRANSFORMER COMPANY  
7620 Eastlake Terrace Dept. G Chicago

**POWER  
CLAROSTAT**  
REG. U. S. PAT. OFFICE

Ask your dealer or send to us direct for literature.  
American Mechanical Laboratories, Inc.  
285 North Sixth Street Brooklyn, N. Y.

**BOSCH RADIO**

AC and DC Models, Cone Type Reproducer,  
Power Units, and Phonograph Pick-Up Device.

AMERICAN BOSCH MAGNETO CORP.  
Springfield Mass.

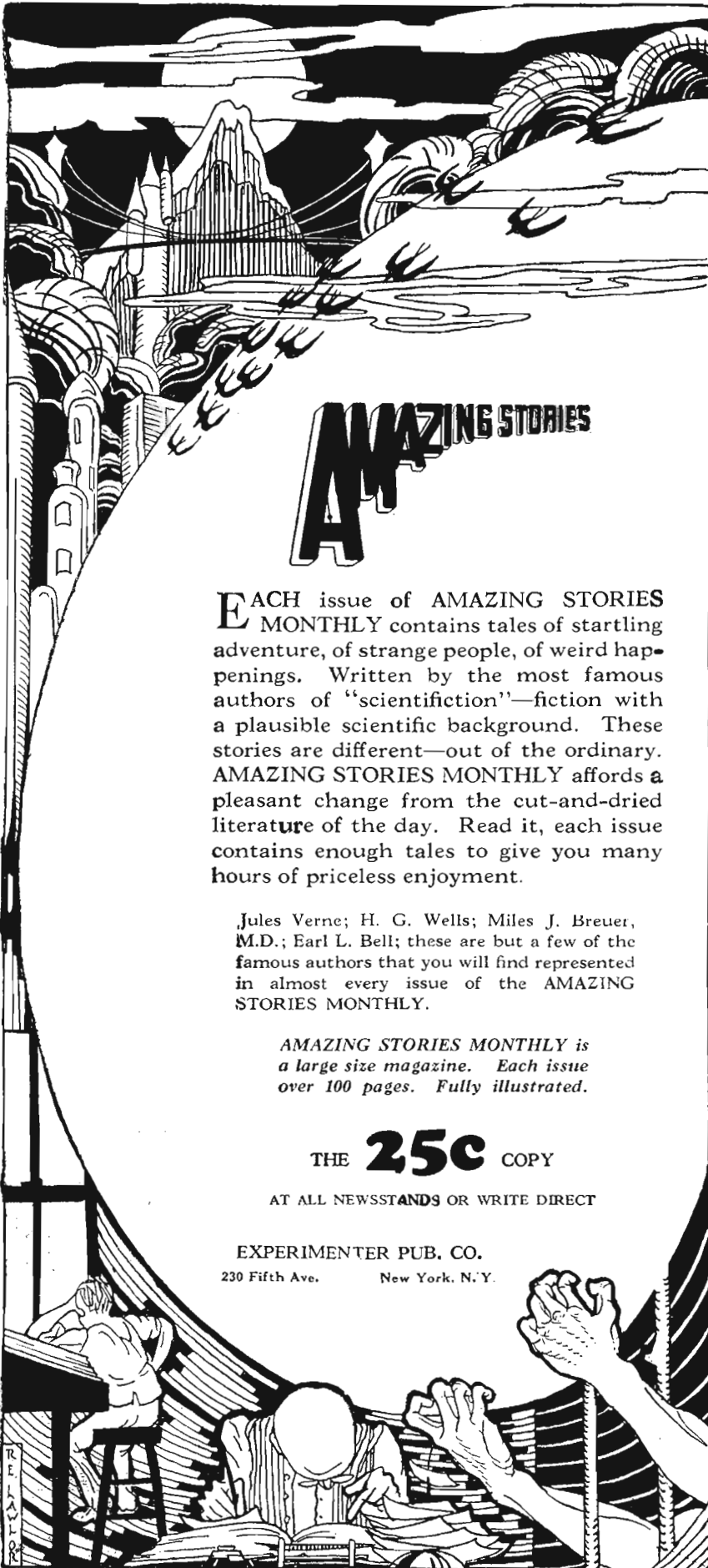

# AMAZING STORIES

**E**ACH issue of **AMAZING STORIES MONTHLY** contains tales of startling adventure, of strange people, of weird happenings. Written by the most famous authors of "scientifiction"—fiction with a plausible scientific background. These stories are different—out of the ordinary. **AMAZING STORIES MONTHLY** affords a pleasant change from the cut-and-dried literature of the day. Read it, each issue contains enough tales to give you many hours of priceless enjoyment.

Jules Verne; H. G. Wells; Miles J. Breuer, M.D.; Earl L. Bell; these are but a few of the famous authors that you will find represented in almost every issue of the **AMAZING STORIES MONTHLY**.

*AMAZING STORIES MONTHLY is a large size magazine. Each issue over 100 pages. Fully illustrated.*

THE **25c** COPY

AT ALL NEWSSTANDS OR WRITE DIRECT

EXPERIMENTER PUB. CO.

230 Fifth Ave. New York, N. Y.

ling, which might take place as a result of the *resistance* in the output circuit of the power-supply devices. Frequently, this is the only way in which howling and "motorboating" may be prevented; particularly when "resistance-coupled" or "impedance-coupled" amplifiers are operated from "B" socket-power units. With these amplifiers, an audio choke and a by-pass condenser, connected in the plate lead of the detector stage, and also in that of each detector stage, will usually obviate the troublesome effects altogether.

Fig. 5 shows the method of connecting an A.F. choke and an A.F. by-pass condenser in the plate circuit of a detector or an audio amplifier tube. Diagram A shows the usual method, with the choke coil connected in the "B" supply wire to the transformer T<sub>2</sub>, and the by-pass condenser C between the "B+" side of the transformer and the filament ("B-"). With this circuit the A.F. current must return directly to the filament through the by-pass condenser because, after the current passes through the primary of the transformer, the choke coil prevents it from entering the "B" supply circuit.

Diagram B shows another method, which is sometimes used when the plate current of the tube is heavy, and in any case where the core of the transformer might be saturated by the plate current. The advantage of the system ("shunt-feed") is that the direct plate current does not pass through the transformer winding, but is delivered directly to the plate through the choke coil connected in series with the "B+" wire. Also, by this method, the insulation of the transformer is not subjected to high voltages. In this circuit the by-pass condenser is connected in series with the wire to the primary of the A.F. transformer from the plate of the tube and the A.F. choke coil. This condenser makes it possible for the A.F. current to pass from the plate, through the A.F. transformer, and to the filament circuit.

## 40 Non-Technical Radio Articles

every month for the beginner, the layman and those who like radio from the non-technical side.

**SCIENCE AND INVENTION**, which can be bought at any newsstand, contains the largest and most interesting section of radio articles of any non-radio magazine in existence.

Plenty of "How to Make It" radio articles and plenty of simplified hook-ups for the layman and experimenter. The radio section of **SCIENCE AND INVENTION** is so good that many **RADIO NEWS** readers buy it solely for this feature.

### Radio Articles Appearing in June Science and Invention Magazine

Giant Loud Speaker Fills Theatre  
A Radio-Equipped Yacht  
How to Build a Large Cone Speaker  
Making a Double-Cone Speaker  
New Radio Devices  
Radio Oracle—Questions and Answers  
Latest Radio Patents

**PROTECTING THE SPEAKER**

Since power tubes have become generally used in the last audio-frequency stage of receivers, the use of an A.F. choke coil and a by-pass condenser in the output circuit of a receiver is almost universal practice. The purpose of this choke-and-condenser combination is to allow the A.F. current to pass through the loud speaker and, at the same time make it impossible for the plate current of the tube to flow through the windings of the loud-speaker unit. This is absolutely necessary in many cases; as the heavy plate current required by the power tube would be sufficient to burn out the fine wire in the loud-speaker unit or, at least, it might "saturate" the winding, and the results would be almost equally unsatisfactory.

Fig. 6 shows the method of connecting a choke coil and a by-pass condenser ("tone filter") in the plate circuit of the last A.F. stage. Diagrams A and B are for the usual amplifier arrangement, and diagram C is for the "push-pull" amplifier. At A is indicated the arrangement followed when the choke coil and condenser are a part of the receiver proper; and the chief advantage of this circuit is that the loud speaker is at ground potential. When the choke coil and condenser are connected externally to the receiver, however, the circuit shown at B is usually used because of its greater simplicity. Both circuits give identical results; but in the use of the latter the loud speaker is kept at a high potential, which is sometimes considered unwise. When a push-pull circuit is used, a special choke coil is required; this coil is twice as large as the usual choke and has a center tap for connecting the plate supply wire. As both ends of the choke coil are at the same D.C. potential, it is not necessary to use by-pass condensers in the wires to the loud speaker; but, if it is desired to keep the loud speaker at ground potential, two condensers may be connected in the positions indicated in dotted lines.

**"IMPEDANCE" A.F. COUPLING**

An "impedance"- (capacity-) coupled audio-frequency amplifier circuit is another place where A.F. choke coils are required in numbers. In these circuits choke coils are used for two different purposes; so that two choke coils as well as one by-pass condenser are required in each stage. Fig. 7 shows the circuit arrangement usually employed; in this the by-pass condensers C are used to transfer the audio-frequency energy from the plate (output) circuit of one stage to the grid (input) circuit of the next stage. The choke coils L provide a path for the direct ("B") current to the plate of the tube and, at the same time, prevent the A.F. component of the current from returning to the filament without going through the condenser C. The choke coils L1 allow the charges on the grids of the A.F. amplifier tubes to leak back to the filament.

In the first part of this article it is stated that choke coils and by-pass condensers may often be removed from a receiver without affecting the results. The fact is that, under certain receiving conditions, if a choke coil were short-circuited the music would not be affected; but under other conditions the choke would greatly improve the results. The fact is, that a receiver fully protected with chokes is more stable in operation and is capable of giving superior performance under most conditions.

The number of choke coils required varies with the circuit used, but Fig. 8 shows the positions in which choke coils may be used to advantage, in practically every receiver. Of course, special circuits often require many additional chokes and by-pass condensers.

The uses of audio chokes, which have been considered thus far in this article, are those of the choke coils which are used in the receiving set proper. However, probably more choke coils are used in power-supply units for radio receivers, than for any other purpose. When used in this way they are part of a filter circuit consisting of two or more choke coils and a condenser "bank." (Filter circuits are provided to smooth out the ripple in the interrupted direct current which is delivered by the rectifier; i.e., to remove the 60-cycle hum from the direct-current output of the rectifier tube.) The action of a filter circuit requires a rather lengthy explanation, and, therefore, it will not be fully covered in this article. However, it may be said that the choke coils retard the pulsating component of the current and the condensers act as reservoirs, which become charged at "peak" voltages and discharge smoothly between "peaks." By use of combinations of chokes and condensers, in a circuit similar to that illustrated in Fig. 9, it is possible to change a pulsating direct current into direct current pure enough to operate the plate circuits of radio tubes.

In their construction, both R.F. and A.F. choke coils offer more complications than one might think. In the case of the R.F. choke coil it is necessary only to wind a coil of wire possessing sufficient inductance (and therefore impedance) to offer an effective barrier to the radio-frequency current which it is desired to block. However, in winding the coil the maker must take care to see that the distributed capacity is as low as possible. If the distributed capacity of a coil is high, this capacity tends to short-circuit the coil, thus destroying its utility. Several methods have been developed for winding coils having a very low distributed capacity, and one of them is illustrated in the picture shown on page 1366. In this system, the coil is wound on a small wooden bobbin, in three or more sections of various widths. In most cases, the end of the wire leading from the smallest-winding section is connected to the high-potential side of the circuit.

In winding A.F. choke coils, the problem is to produce a coil which will have sufficient inductance when a comparatively high current is passing through the winding. This is a problem which concerns the manufacturer more than the experimenter; because it is rather impractical for the latter to attempt to build a home-made A.F. choke coil. However, it is important for the constructor to select an instrument which possesses the proper inductance and suitable current-carrying rating for the particular circuit in which it is to be used.

**Keep the Loud-Speaker Cord  
Away from the Lead-In**

**I**N running a length of wire from the receiver proper to the loud speaker, if the latter is separated any distance from the former, be careful to keep this wire away from the aerial lead-in. If the two are too close together, a very persistent and annoying howl will develop.

**They make  
\$6,000**

**a year**

**The facts prove that  
YOU can achieve  
Success in Radio!**

Radio News writes us:

*"In looking over the dealer mail received in the last three months we find that the average income of all dealers who gave us their income figures, 38 in number, averages more than \$6,000 a year."*

{Signed} C. W. EMERSON

RADIO NEWS

Why don't you think this over and say to yourself, "These dealers are no smarter than I am. If I knew radio thoroughly, I could make that much and more. I know that the Radio Institute of America is America's oldest radio school—that it gives the finest radio instruction obtainable anywhere, and the finest and fullest radio equipment.

"I know that RIA is conducted by the Radio Corporation of America and is backed by General Electric and Westinghouse—that their course in radio is complete and entirely covers every phase of radio, including operating, broadcasting, in fact *everything* in radio. I know that I can make progress because everything is told so clearly. I can get this instruction at home, and prepare for success in radio without giving up my present job. I can study when I please and as long as I please. With the tremendous opportunities opening up in radio today, I certainly can't pass up this opportunity to learn more about the RIA course. Here's one coupon I will clip. I want the full facts."



Tear out the coupon and mail it now.

**RADIO INSTITUTE OF AMERICA**  
Dept. A-6 326 Broadway, New York City

**RADIO INSTITUTE OF AMERICA,** Dept. A-6  
326 Broadway, New York City

Dear Mr. Duncan:

Please send me your new catalog. I want to know more about your new radio course.

Name.....

Address.....

.....

# 90 Volt Power Unit :: \$12.75

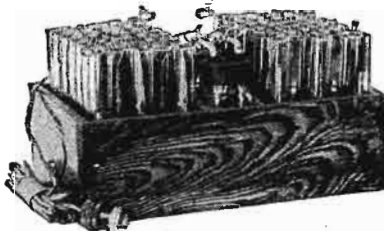

Hums, line noises, etc., positively impossible with this new advanced unit. Plug in and forget. Non-acid and noiseless. All detector and intermediate voltages plainly marked. Simpler to hook up than dry cells. Operates any type set 1 to 12 tubes. Greater volume and clearness guaranteed. If not thoroughly satisfied return after using 30 days for complete refund. Guaranteed further 2 years. For 110-120 volts A.C. 25 to 60 cycle current, 90 volts, \$12.75; 112½, \$15.25; 135, \$17.50; 157½, \$19.50; 180, \$24.00; 202½, \$26.00. Also built for D.C. current 110 and 32 volts at only \$3.00 additional, any size above. Ample stocks—same day shipments. Simply say—ship C.O.D. or write for my interesting literature, testimonials, etc.

## B. HAWLEY SMITH

334 Washington Ave. Danbury, Conn., U. S. A

### Your Set Can Now Get Short Waves

Sent anywhere in the U. S. post paid upon receipt of price. Canada and Foreign, 60c additional. Money order only. Also sent C. O. D. plus postage in U. S. if \$1.00 accompanies order to insure carrying charges. In ordering be sure to name set and tubes used, such as UV199, UX199, WD11, 201A, UX226 or UV227. Price \$15.00 or \$17.50 for A. C. Sets.



### The SUBMARINER

will convert your regular set into a short-wave receiver by simply inserting a plug in place of one of the tubes. This takes but a few seconds. With "Submariner" it will enable you to tune between 25 and 65 meters. This device operates with all sets, such as T.R.F., Neutrodyne, Super-Heterodyne and others A.C. or D.C. operated. No additional tubes, batteries, or coils required. If set operates a speaker it will do so with "Submariner" attached. Operates a wave changer with Super-Heterodyne and as detector unit with others.

### SHORT-WAVE RECEPTION

is practical, and especially in summer, as they penetrate better and there is less static. The "Submariner" waveband includes practically All Powerful Stations Which Broadcast Programs. You may also listen to amateurs from all parts of the world who transmit code messages. You will have one of the most efficient short-wave receivers when the "Submariner" is attached to your set. Get a "Submariner" so you may have command of the short-wave activities as well as the broadcast band. If your Dealer does not carry

### ORDER TODAY DIRECT

This device has been nationally advertised, and sold in all parts of the world for the past two years

J-M-P MANUFACTURING CO., INC.  
Department 53 Milwaukee, Wis., U. S. A.



### Build LACAULT'S Latest

ALL WAVE ELECTRIC  
Quick Shipments "R. E. L. 9" All Parts in Stock

Write for our list of "Specials"  
—lowest prices in country.

**R. F. LACAULT**  
RADIO ELECTRIC LABORATORIES

116 WEST 65th STREET NEW YORK CITY

## TABLE TYPE CLAROSTAT

REG. U. S. PAT. OFFICE

Ask your dealer for a copy of "Radio Edquette" or write direct. American Mechanical Laboratories, Inc., 285 North Sixth Street, Brooklyn, N. Y.

## How Many Stations on One Wavelength?

(Continued from page 1312)

from long distances at night. This distortion may add to or decrease the total distortion at the time.

### CHANGE OF FREQUENCIES

Then, too, quite a large number of stations broadcast chain programs for an hour or two only. When a station came into or left the chain program, this would compel it to revert to its former assigned frequency. From 15 minutes to several hours is required to change the frequency adjustment of most present-day transmitters; this would mean that such time must be wasted. Also, the few hours during which such a station was connected to the chain would not be of great value to another station which desired to use the channel thus vacated.

If a great number of stations were broadcasting the same program, there would undoubtedly be many localities where a given receiving set would receive some energy from quite a large number of stations. This would prohibit the announcing of call letters by the individual stations; as it would be necessary that all transmissions from every station be identical. If, for example, each station did announce its individual call letters, those listeners who were within range of more than one station would hear the announcements from these different stations clashing in at the same time. Though it might be possible to have each station announce its call letters in turn, this would be impractical, as it would require a great deal of time for each station of a large chain to announce its call letters.

Stations, therefore, being unable to establish their individual identities would suffer an advertising loss which would result in a great decrease of their value to the company sponsoring the chain broadcast.

### CARRIER-FREQUENCY REGULATION

Considering the second phase of the question, the problem of maintaining more than one station on the identical frequency, is one which is not commercially practical as yet. It is absolutely necessary that the frequency of all transmitters of the chain be maintained exactly the same; if this were not done, the various waves from several stations would interfere and clash with each other; producing whistles of varying intensity and pitch, even if no program were being broadcast.

Practically every listener is familiar with the whistles heard on some of the broadcast frequencies; this is due to slight difference in the carrier waves of the stations, operating on that channel. For instance, suppose two stations sufficiently near are broadcasting on the 1260-kilocycle channel; but one of the stations is slightly off its correct frequency and operating on 1261 kilocycles, and the other station is maintaining its carrier-wave on exactly 1260 kilocycles. The two fundamental frequencies will produce a third, equal to the difference between 1261 kilocycles and 1260 kilocycles, or 1 kilocycle. This one-kilocycle frequency is heard as a fairly high pitched whistle, or 1000-cycle note.



## Tune With Ease

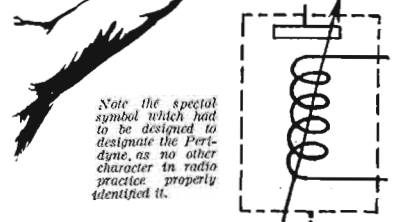

## Build The PERIDYNE Designed by HUGO GERNSBACK A One Dial Receiver!

THE "Peridyne Five," because of new principle employed in its construction, assures positive interstage resonance, and thus the EFFICIENT one dial receiver becomes a reality. The Peridyne was designed by Hugo Gernsback, well known inventor and editor of several popular magazines. Until the invention of the PERIDYNE it was practically impossible to obtain exact resonance between the RF stages of the Radio Receiver, due to the fact that the least little change in the spacing of the coil windings or the number of turns threw the particular stage out of resonance with remaining RF stages. Now, with Hugo Gernsback's Peridyne it is possible to adjust each stage of the receiver so that it will be in perfect resonance with each of the succeeding stages. This is the principle that makes the PERIDYNE the efficient receiver that it is.

The PERIDYNE has again and again proven its ability as a DX set, both in the summer months and in the winter. When built according to specifications it is one of the most satisfying Receivers possible to obtain. Remarkably clear tone reproduction, selectivity, and 100% efficiency—these are the high lights of the Peridyne success.

The Conrad Company, the oldest and original Radio pattern publishers, have prepared a full set of blueprints, diagrams and specification sheets from which this remarkable Radio Receiver can be built. Every question regarding the building of the PERIDYNE is fully answered in the 16-page instruction booklet that is part of the Peridyne Pattern.

Write today—get a Peridyne Pattern—you are sure to enjoy the results that the "Peridyne Five" will give you

Full constructional data

# 50c

THE CONRAD CO., INC.  
230 Fifth Ave., New York, N. Y.

THE CONRAD COMPANY, INC.  
230 Fifth Avenue, New York N. Y.

Gentlemen: Kindly send me a full set of blueprints and all data required for building the new efficient Peridyne Receiver. Enclosed find 50c to cover.

Name.....  
Address.....  
City.....State.....

If both stations were operating on exactly the same frequency, however, the difference would be zero and no note would be heard; this condition is called "zero beat." The slightest deviation is not permissible, which requirement eliminates the use of "manual control," wherein one station's carrier is kept at the same frequency or "zero beat" with another, by the operator of one station listening in on a receiver at a remote point and adjusting his own transmitter by hand to "zero beat" with another when a whistle is heard caused by his station operating on a different frequency from the other stations operating on the same channel. Nor will automatic devices do to produce this result, as they require that the station's carrier-frequency change slightly before it may be restored to the proper frequency.

Controlling two or more stations from one crystal requires great multiplicity, and therefore great expense, in wire connections between the various stations. A system, whereby synchronous operation is effected by one station's (when varying from its correct frequency) producing a similar variation at another, has been accomplished; but this is expensive, especially where there is any great distance between the stations so controlled.

Because of the distortion taking place during wire transmission or due to differences in the amplifiers used and in the actual transmitter, it is not considered practical at this time to provide a single channel on which a chain program should be broadcast. The result would probably be that only those listeners within close range of but one station, where no perceptible effect would be produced by the transmission from other stations, would be able to receive the program clearly. Any listener whose receiver was affected by more

than one station would probably hear nothing but discordant tones.

However, if it ever becomes practicable to have chain programs broadcast on a single channel, the advantages resulting will be numerous. These will be explained in another article to follow in the near future.

(Another interesting phenomenon which might arise, in case a number of high-power stations were operating on exactly the same fundamental frequency and with identical programs, even after the technical problems above listed have been satisfactorily solved, is that of interference due entirely to the location of receivers in the areas at which two stations come in with approximately equal strength. There might then be expected to occur an effect similar to the fringes of color noted where two light waves alternately strengthen and cancel each other; at points where the signal of one station had to travel one-half a wavelength farther than that of the other, the two should completely cancel each other, except as the directional characteristics of the receiving aerial might overcome this interference. However, it may be remarked that this condition would probably not manifest itself in inability at all times to receive either station; but in a peculiar fading effect, as the paths of the waves were alternately lengthened and shortened slightly by the changes in the condition of the atmosphere. Some experiments have of late been made in operating two stations with the same program on the same frequency, as related above; and we will be very glad to hear from any of our readers who live where the normal field strengths of two such transmitters are nearly equal, as to the constancy of the signals received by them.—EDITOR.)

## A Britisher Chats on Radio

(Continued from page 1313)

"How I motored by night from Ogdensburg to Ottawa, and the reason why. A Problem Story." Or even, Among the lion-hunters of Fifth Avenue."

But what do we get? Shades of White Corpuscles! "The History of the Frozen-Meat Trade;" "The Romance of Bimetallism from 1843 to 1926;" "Furnishings in Oak;" "Evolution of the Morris Dance;" "History of the Coffin-Makers' Guild from the time of Henry the First;" "The Influence of the Etruscans on Grecian Burial Ceremonies;" "The Evolution of Hot-water-pipe Systems."

### THE ETHEREAL EXILES

From the B.B.C.'s chamber music and talks has sprung the great British amateur radio movement: the movement being an escape. Anything British amateurs have done in the DX line has been directly inspired by the desire to evade British broadcasting. Our most prominent amateurs openly declare that they would rather eavesdrop on a lecture by a Thibetan band of nose-flautists playing on instruments made

of human thigh-bones, than endure the customary B.B.C. fare; not because the good in it is so insignificant, but because the bad is so venomous.

In order to give you the proper hang of the real amateur movement in this island, I must explain that it is impossible for a man here to get a license permitting him to hook up and operate a transmitter, unless he can satisfy the post office that his intention is to engage in genuine research, the object of which must be stated and must satisfy the post office. If a man said, "Look here! I want to work a set purely for the fun of communicating," the post-master general would do one of two things: (a), Resign; or (b), call in the law lords to see whether they could not frame up a charge against the sinner which would earn for him a couple of months in prison, or, as some American Milton says, in the "hoosegow."

(I do not care much for "hoosegow;" it is ugly. "Frazzle" has music; "hootch" has the virtue of conveying the right idea without circumlocution; "piker" is sufficiently

## SKINDERVIKEN Transmitter Units

95c



Two for \$1.75

Have hundreds of uses. Every amateur should have two or three of these amplifiers in his laboratory.

### A FEW USES FOR THESE UNITS

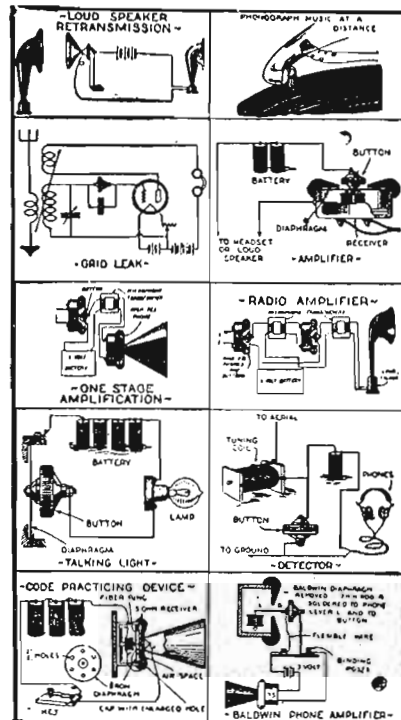

### 12 PAGE INSTRUCTION BOOKLET

containing suggestions and diagrams for innumerable uses, furnished with each unit.

**WE PAY \$5.00 IN CASH**

for every new use developed for this unit and accepted and published by us.

### P. G. MICROPHONE TRANSFORMER



A Modulation Transformer specially designed for use with the Skinderviken Transmitter Unit.

**\$2.**

### FOR SALE AT LEADING DEALERS

Or Order Direct, Using Coupon Below

### SEND NO MONEY

When the postman delivers your order you pay him for whatever you have ordered, plus a few cents postage.

PRESS GUILD, INC. R-6-28  
16-18-R—East 30th St., New York, N. Y.

Please mail me at once as many of the following items as I have indicated.

... Skinderviken Transmitter Units at 95c. for 1: \$1.75

for 2: \$2.50 for 3: \$3.20 for 4:

... P. G. Microphone Transformers at \$2.

When delivered I will pay the postman the cost of the items specified plus postage.

Name.....

Address.....

City..... State.....

# AVIATION



*-in all its phases!*

Complete instruction course in three volumes. Every point of aviation efficiently and thoroughly treated. Subjects covered in these volumes—

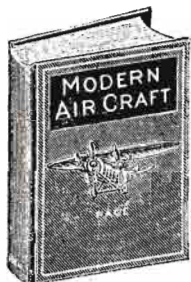

## MODERN AIR CRAFT

700 Pages  
500 Illustrations

Contents of each chapter—  
I. Aircraft Types. II. Lighter-than-Air Craft. III. Early Airplane Designs. General Design Considerations. IV. Design and Construction of Aerofoils. V. Arrangement, Fabrication and Bracing of Airplane Wings. VI. Airplane Fuselage and Landing Gear Construction. VII. Airplane Power Plant Types and Installation. VIII. Aviation Engine Design and Construction. Air-Cooled Engines. IX. Aviation Engine Design and Construction. Water-Cooled Engines. X. Aviation Engine Auxiliaries. XI. Aircraft Propeller Construction and Action. XII. Airplane Equilibrium and Control Principles. XIII. Uncovering, Setting Up and Aligning Airplane. XIV. Inspection and Maintenance of Airplanes and Engines. XV. Details of Modern Airships and Airplanes. XVI. Seaplanes, Flying Boats, Amphibians and Other Aircraft. XVII. Some Aspects of Commercial Aviation. XVIII. Aircraft Instruments and Aerial Navigation. XIX. Standard Nomenclature for Aeronautics Report No. 249, Part I.

This book is written in simple, understandable language.

PRICE \$5.00

## AVIATION ENGINES

This treatise, written by a recognized authority on all of the practical aspects of internal combustion engine construction, maintenance, and repair, fills the need as no other book does. The matter is logically arranged; all descriptive matter is simply expressed and copiously illustrated, so that anyone can understand airplane engine operation and repair even if without previous mechanical training. This work is invaluable to anyone desiring to become an aviator or aviator mechanic.



274 PAGES

PRICE \$1.25

## A. B. C. OF AVIATION

This book describes the basic principles of aviation, tells how a balloon, or dirigible is made, and why it floats in the air. Describes how an airplane flies. It shows in detail the different parts of an airplane, what they are, and what they do. Describes all types of airplanes and how they differ in construction, as well as detailing the advantages and disadvantages of different types of aircraft. It includes a complete dictionary of aviation terms and clear drawings of leading airplanes.

PRICE \$1.25

Remit by cash; stamps, check, or money order  
No C.O.D.'s

We Pay Postage On All Books

CONSRAD COMPANY, Inc.  
230 FIFTH AVENUE NEW YORK

scurrilous for ordinary purposes and presents no easy excuse for repartee; and "hobo" is a word of power, photographic and unerring in intent. But "hoosegow" is as dead as a medical student's first patient.)

The chief result of the post office's jealousy about transmission licenses has been to concentrate the energies of the boys upon the construction and use of receivers. A few imaginative persons have succeeded in cockering up programmes of research which have deluded the post office—and that is really not difficult, because the P.O. is backward in radio matters—and some of them have waggled the ether very effectively.

### THE H'ENGLISH 'AMS

Young Goyder (2 SZ), a schoolboy, in February, 1927, amused himself by making two-way contact, in Morse, with a whaling-ship off the Great Ice Barrier, 250 miles within the Antarctic Circle; three years before, he had worked with an amateur in New Zealand. Gerald Marcuse (2NM) gets everywhere and anywhere and specializes in talking to exploring expeditions; he worked two-way Morse with the Rice Expedition in Brazil, and telephony-Morse (in daylight) with a ship in Wellington Harbor, New Zealand. E. J. Simmonds (2OD) reckons Australia, New Zealand, and Mexico neighbors. J. A. Partridge (2KF) prefers the wild and woolly places; he chats with Borneo, Papua, Manila and Saigon. F. A. Mayer bagged the scalp of the U. S. Army Signal Corps, Philippines, and there is another youngster, whose name I forget, who kindly takes messages from British Air Force posts in Iraq and hands 'em to the Air Ministry when he is not too busy doing the same for the Navy in respect of Hong Kong. And Gerald Marcuse gives regular broadcasts for the benefit of overseas Britons, by permission of the post office, while our B.B.C. is figuring out how to do it. Give 2 NM a call and judge of his quality.

### OUT WHERE CANOPUS SWIMS

Now for the humbler dial-twisters, great in their lesser orbits. First place to the DX hounds, pure and simple. They live in one dimension, length. To them the globe is a rotten shriveled-up pip; a paltry 12,000 odd miles is all the backyard they have to play in. Small wonder that we hear the word Mars mentioned every six months. They regard it as a flaw in the evolutionary process that Mars is so cussedly reticent, to say nothing of the silence of *Alpha Centauri*. There ought, in a properly-regulated universe, to be transmitters in Heaven, they say.

However, having reduced all the miles in creation to millimeters, these poor fellows, in order to demonstrate their skill, have had to reduce their tube-power—to fight, as it were, with one hand tied behind. So now the hall-mark of a radioking is his reception of Australian broadcasts on *one tube*. Not bad work, short waves, or not. Eh? And there are plenty here that have done the trick. Yet a winning circuit is not alone sufficient. Give them a slight *rah rah*. Thank you!

### THEIR QUEST IS QUANTITY

Now allow me to introduce the Noisy Boys. These lads—clever, but had members of society—judge their radio results in terms of acoustics. No signal is admitted by them as truly elect if it fails to rattle the crockery in the kitchen or bend

the walls of the house outward. The Noisy Boy considers that he has satisfied the demands of Destiny if he gets Prague, or Madrid—or what you will—loudly enough to shake a pic off the pantry shelf or shatter the vases on the doo-de-la-day.

I had a letter recently from a promising boy of fourteen years, which said that its writer was rousing the neighborhood with *blah-blah* from a loud speaker, when, enter a policeman who had looked to find a gang-fight. Said the cop, "How many tubes? Six?"

"Three! And here's a blue-print of the hook-up," was the reply.

The cop resigned from the force three days later and became an Episcopal lay-preacher, so that he might have leisure to pursue radio.

Talking of theology, the worst job that ever I heard of over here was the feat of an ingenious Noisy Boy who hitched seven power tubes to a loud speaker driven by compressed air and, having tuned in Rugby Radio by mistake, blew a churchwarden through the window of a cocktail-parlor where he landed at the feet of the Senior Deacon who had looked in to study the Devil and his ways. Yeh!

A clearly-defined type of "fan" is the Experimenter. He treats the devious by-ways of the art, always looking for that to happen which is dead against the regulations. He cherishes a hope that he will hit upon a longitudinal ethereal vibration. He believes that, if he wastes enough chemicals, he will find the storage battery which delivers oscillatory current at ten million cycles. He does to orthodox circuits things which, to behold, would make even Reinartz and Colpitts scream with pain. He is forever on the verge of inventing a tube containing an atom-crushing plant, thus supplying energy enough to run the receiver—and the refrigerator as well. Judging from the pictures which I see in your popular-science magazines, America knows all there is to know about this harmless science. Therefore I pass on to consider The Young Scientist, one of the prettiest things to watch in the whole galaxy of gadget-grinders.

### THE ELEVENTH PLAGUE

The Y.S. was born in spectacles and cut his teeth on a slide-rule; science is his mission; in its interests he was incarnated. You pull off in his hearing a mild joke about the radiation resistance of your antenna being low-loss, and he comes hurtling forward with a text-book in which, on page 900, you can plumb the abysmal depths of your ignorance. When you explain it was a joke he implies either that you are a liar or that you have blasphemed. The only occasion when he smiles is when he finds he can express a dab of static, coming from the N.N.E., with velocity forty millimeters a millisecond; in a foot-and-a-half more algebra than can Professor Morecroft, and beat even Steinmetz by at least a couple of three-ply cosines.

He is a mad measurer; he measures his amperes as they go in; hesitates, suspects, and then runs round the set to measure them as they come out. His receiver is just a dashboard and his listening is all looking. The greatest works of musical art are for him but the waggling of pointers in his meters. If he could meet Handel he would want to measure the force of his grip. When he sees the name of Tchaikovsky he thinks it is the formula for the

torque of a catswhisker. Dogs flee from him, fearing that he will verify the length of their tails. He will probably die young, choked by a milliammeter administered by a man who built a set, bragged to his wife, and was then proved to be a fool because the grid-plate current of his fourth tube was short of two kicks and a wiggle on the Y.S.'s accursed meter. Brothers, do you bury many of this brand?

(YES, WE HAVE 'EM, TOO)

What a relief it is to contemplate, with the serene, lofty benignity of the perfectly veracious, the ingenuous countenance of the Common Liar. He was twenty minutes—no, to be strictly truthful, twenty-three minutes—behind Marconi in hooking-up the first radio set. Perhaps his watch was fast, but he will generously waive that point. Anyway, he knows what he knows, and he could show you his note-books, if he could find them, etc., etc. But let that pass. Some sneak in and collar the glory but, when the truth is known, there are those that will look cheap, he can assure you. Why! only yesterday he was talking to—

Sets? Pah! What Armstrong does tomorrow he did in 1913 and thought no more about it. If only he could lay his hand on those plaguesy notebooks! Yes, he was the man who first thought out the radio tube. Didn't develop the idea because—tightness of cash—current thought not then ready for sensational advances in practice—vested interests too deeply dipped in regard to crystals and magnetic detectors—etc., etc.

## The Port of Missing Airplanes

(Continued from page 1323)

wearing the phones which picked up the signals of the radio beacon; for although the transport was equipped with the conventional three-light visual indicator, the NAEC regarded it necessary for the pilot to keep a check at all times upon the operation of the beacon, least some stray signal or other accident give a false reading. Beside Dare sat the NAEC's world-famed aeronautico-medical specialist and psychologist, keeping a watchful eye on the film hero's movements. Scott sat a little behind, watching the most important of the instruments, his new gyroscopic band-and-turn indicator, which not only gave visible indication of the vertical position of the ship, but made a permanent record of the plane's movements. Thus any incident in the flight could be checked by its time, to determine the transport's position at that instant.

For hours the plane roared on, but there was no hint of anything unusual. Scott, who was studying a bundle of reports upon the previous crashes, frowned.

"From these records," he remarked, "it appears that all four of the planes were forced down in an area within a radius of but fifty miles."

The engineers looked up from their instruments. "What does this mean?" one of them demanded.

"It means," replied Scott, that a new mystery complicates the problem. Can there be, out in mid-Pacific, an aerial Sargasso, which no ship of the air can penetrate? Is there some strange, mysterious current

Perhaps we don't know that he first had the idea of the third electrode—final E silent, as in "melon." No? Ah! secret history. Time will show! Television? Pooh! In 1897, he wrote a paper (under pressure of the Royal Society) to show that if—and if—and if—then, of course it was easy to transmit the image, etc. Great impression at the time! But current thought conservative; Queen Victoria expressed her disapproval of any such thing. Archbishop of Canterbury found nothing in Holy Writ to warrant such procedure. House of Lords snorting all over the shop at mere thought of possibility of shooting almost sacred lineaments of heirs to dukedoms from castle to cottage.

But—if you want to hear every broadcast station in the world, on a two-tube set, of my own design, with an antenna four inches long and no inches high, through a loud speaker made out of junk, with no batteries, no "ground," no nothing, and less coils, I'm your man.

Gentlemen, do you know this fellow? If you have not his like I am greatly surprised and will use my utmost endeavors to have him shipped over to Ellis Island, from which health resort your hospitality will, I doubt not, speedily rescue him. And you may keep him. It's a gift. You have the best of our Old Masters. Take the cream of our Prize Liars, cousins.

P.S. The Editor says I called twopence 20 cents instead of 4-point-something cents in my first article (see February issue). I did. I was dreaming of the millennium, when the dollar will be worth half a yen and the pound sterling 20 yen.

which sends planes down to destruction? At any rate, it appears that about ninety-three tonight, we shall pass through the area in which the four transports met disaster. Until then, we can only speculate."

The day passed without event. With the coming of darkness, the transport ran into a dense fog which rendered the moon and stars invisible; but the radio beacon still held the ship straight to its course.

It was not until 9:50 p. m., that there appeared any hint of the unusual. Then, without warning, Dare pulled back sharply on the stick. Scott felt the nose of the ship lift. He saw that Dare was staring incredulously at the bank-and-turn indicator.

"The instrument is wrong!" exclaimed Dare. "We are diving!"

The indicator showed that the nose of the ship was pointing upward; but still Dare pulled back on the stick. The indicator quivered, then suddenly went wild.

"We are in a tail-spin!" cried Scott, wildly gesticulating toward the indicator.

Dare nodded and swung the controls. Again the nose lifted. Suddenly the indicator spun about, and aghast, Scott saw the altimeter drop—2,000—1,500—1,000—500 feet—

He motioned frantically for Dare to trust to the indicator. Puzzled, Dare obeyed. He inclined the stick, and the altimeter gradually rose.

With his eyes on the indicator, Dare unbuckled the strap on his helmet and removed the headphones from his ears.

## New AERO Circuits For Either Battery or A. C. Operation

Proper constants for A. C. operation of the improved Aero-Dyne 6 and the Aero Seven have been studied out, and these excellent circuits are now adaptable to either A. C. or battery operation. A. C. blueprints are packed in foundation units. They may also be obtained by sending 25c for each direct to the factory.



### AERO Universal Tuned Radio Frequency Kit

Especially designed for the Improved Aero-Dyne 6. Kit consists of 4 twice-matched units. Adaptable to 201-A, 199, 112, and the new 240 and A. C. tubes. Tuning range below 200 to above 550 meters.

This kit will make any circuit better in selectivity, tone and range. Will eliminate losses and give the greatest receiving efficiency.

Code No. U-16 (for .0005 Cond.)..... \$15.00  
Code No. U-163 (for .00035 Cond.)..... 15.00



### AERO Seven Tuned Radio Frequency Kit

Especially designed for the Aero 7. Kit consists of 3 twice-matched units. Coils are wound on Bakelite skeleton forms, assuring a 95 per cent air dielectric. Tuning range from below 200 to above 500 meters. Adaptable to 201-A, 199, 112, and the new 240 and A. C. tubes.

Code No. U-12 (for .0005 Cond.)..... \$12.00  
Code No. U-123 (for .00035 Cond.)..... 12.00

*NOTE—All AERO Universal Kits for use in tuned radio frequency circuits have packed in each coil with a lined primary a twice matched calibration slip showing reading of each 1000 primary AERO Universal Coil at 250 and 500 meters; all having an accurate and similar calibration. Be sure to keep these slips. They're valuable if you decide to add another R. F. Stage to your set.*

### A NEW SERVICE

We have arranged to furnish the home set builder with complete Foundation Units for the above named Circuits, drilled and engraved on Westinghouse Micarta. Detailed blueprints for both battery and A. C. operation and wiring diagram for each circuit included with every foundation unit free. Write for information and prices.

*You should be able to get any of the above Aero Coils and parts from your dealer. If he should be out of stock order direct from the factory.*

## AERO PRODUCTS, Inc.

Dept. 105  
1772 Wilson Ave. Chicago, Ill.

## MUTER Dependable Radio Products

The Complete Quality Popular Priced Line—

Send for Comprehensive Catalog

LESLIE F. MUTER CO. 76th and Greenwood Dept. 827G Chicago

## VOLUME CONTROL CLAROSTAT

REG. U.S.

PAT. OFFICE

Send for 16-Page "Micrometric Resistance" Folder  
American Mechanical Laboratories, Inc.  
285 North Sixth Street Brooklyn, N. Y.

**PATENTS** As one of the oldest patent firms in America we give inventors at lowest consistent charge, a service noted for results, evidenced by many well known Patents of extraordinary value. Book, Patent-Sense, free. Lacey & Lacey, 631 F St., Washington, D. C. Estab. 1889

# Tone- REPRODUCTION

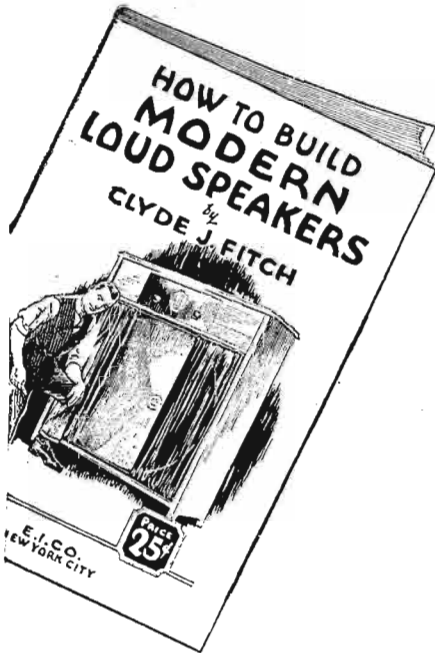

## As you like it BUILD YOUR OWN LOUD SPEAKER

"How to Build MODERN LOUD SPEAKERS," by Clyde J. Fitch, is a complete history of Radio acoustics. Every phase of Loud Speaker design and construction is fully and accurately explained. The many and various methods of attaining true tone reproduction are treated in a clear and concise manner. All types of Loud Speakers, the Exponential Horn, the Cone, the Piezo Electric Speakers, Roll Type Speakers, in fact, every method that has been used to produce clear, audible signals is most thoroughly covered.

The good and bad points of each development are honestly and unbiasedly treated. This is unquestionably one of the most comprehensive treatises on the subject ever written.

### BUILD YOUR OWN LOUD SPEAKER

This valuable book contains full constructional data and diagrams for the building of the Loud Speaker best fitted to give you maximum satisfaction with the particular receiving circuit that you employ.

52 pages—fully illustrated—6" x 9"

**25c**

THE COPY

ON ALL NEWSSTANDS  
OR WRITE DIRECT

THE CONSRAD CO., INC.

230 Fifth Ave. New York, N. Y.

CONSRAD COMPANY, INC.  
230 Fifth Ave., New York, N. Y.

Gentlemen: Enclosed find 25c. Kindly send me a copy of How to Build Modern Loud Speakers.

Name.....

Address.....

City..... State.....

"Mr. Dare," excitedly exclaimed Scott, "you must trust your instruments! They are absolutely correct. We must let this test stand or fall on the reliability of our equipment. Only to save the lives of our men may we deviate from this course. Even the most experienced pilot may err in judgment of position when he can see nothing but the instrument panel before him. Before the first spin, our instruments, as well as my own sense of position, showed that we were flying on a level. Why did you attempt to climb so suddenly?"

"Because I felt very distinctly that we were in a nose-dive. Believing the instruments to be at fault, I trusted to my judgment and compensated by lifting the nose of the ship."

"But according to the bank-and-turn indicator, which I am positive is accurate, you actually climbed so sharply that the plane stalled and dropped backward into a tail-spin. Let us fly by instrument alone."

For a time they flew on a level at 1,000 feet. Suddenly Scott's eye was caught by a pattern traced by the recorder of the beacon receiver. The very-slightly wavy line of the beacon's signals was describing a series of minute ripples.

Scott suddenly busied himself with wires. He disconnected the tape recorder and connected the receiver to an oscillograph. The vibration now was clearly apparent and distinct. Scott quickly estimated its pitch. "About ten cycles," he muttered. "Mr. Dare, are you positive that the ship is now on an even keel?"

"Yes," affirmed Dare. "Quite positive." "Then strap the phones tight and see what is the result."

Dare tightened the buckle. In a moment he spoke: "Now I feel the floor tilt. . . . I think we are diving, although the indicator shows a horizontal position. . . ."

Dr. Leipe leaned forward, staring into Dare's eyes. "See, here!" he exclaimed. "Very distinct vestibular nystagmus—a sure sign of vertigo—" He burst into a barrage of technical phrases.

Scott saw that Dare's eyes were going through a slow oscillation, rolling slowly from right to left, and quickly returning to the right. "He is dizzy!" he cried.

"Yes!" nodded the Doctor. "A case of emmetropia in which the nystagmic symptoms indicate a vertiginous condition."

Suddenly Scott understood. "Doctor," he demanded, "might vibration of the inner ear cause dizziness?"

"Perhaps," agreed the Doctor, "if it were sufficiently severe."

"Then this is the explanation: somewhere nearby is a radio station operating on the same wavelength as the radio beacon, and modulated at a frequency of about ten cycles. Now, the pilot of a NAEC ship wears inside his helmet a pair of headphones. The pressure of the headband seals the sponge-rubber ear cushions tight against his ears. Thus every vibration of the phone diaphragm is transmitted directly through this airtight chamber of the outer ear, into the interior. The inner ear is thus vibrated at a frequency of about ten cycles per second—a pitch too low to be audible, yet probably of great intensity. Now, the sense of equilibrium is located in the vestibule of the inner ear—that triple "labyrinth" of semi-circular canals in three planes. When the walls of the inner ear—and thus the labyrinth also—is vibrated, the little hair cells, or otoliths, which are fastened to the inside of the labyrinth, would

also be vibrated; but because of the inertia of the liquid inside the labyrinth, they are bent back and forth with the movements of the canals, thus producing sensations. Since this vibration is perfectly uniform, these hair cells are moved equal distances each way and would apparently cause two equal and opposite sensations—were it not for the fact, proved by clinical investigations, that movement of these cells in one direction produces twice as much sensation as movement in the opposite direction. Therefore, the brain, receiving two opposite stimuli, one twice as strong as the other, naturally believes the stronger; with the result that the operator feels as if he is falling or turning to right or left. So, our pilots were deceived by their own highly-developed flying sense, which made them the crack flyers that they were."

"Mr. Scott," said Doctor Leipe, "you are right. Vestibular nystagmus very correctly infers a case of spontaneous or induced vertigo entirely independent from otosclerosis, cerebellar peduncular lesions, intracranial, labyrinthine, or vascular affections, or from excessive stimulation of the *lamina spiralis membrana*; in short, without reference either to mesencephalic *Anpassungsvermögen*, on the one hand, or to noctiko-kinetic *Antwortbewegungen*, on the other!"

"Doctor," spoke Harold Dare, "I believe you. There is only one person—nay, fiend—who would be so base as to imperil human life and the future of aerial transportation merely to satisfy his personal hatred. He—whom the film world hates as the vilest villain of history—would stoop to this dastardly deed. He, alone, whose name is—"

"Dandy Diavolo!" cried Scott. "Yes," agreed Dare, sadly. "Such a villainous act would fit perfectly his past career as master villain of a thousand films if not of this story itself. We must now find the fiend, and foil him."

He banked sharply and swung the transport round. Scott plugged a thermogalvanometer into the receiver circuit. A few moments later the meter had risen to a sharp maximum. "Now!" he said.

Dare swung his controls. A light suddenly appeared below. Down swooped the great plane and taxied up beside a long, low, black yacht. In an instant Dare had led his men out across a wing and up a ladder which dangled over the yacht's side. There was no one on deck, but a strip of light showed beneath the door of a cabin on the upper deck. Silently the group approached it—

Dare flung the door open. A tall, black-haired man wearing headphones sat at a table before a commercial-type, duplex radio receiver. At his side, the yacht's radio operator watched over a group of instruments connected by wires to a tall-pannelled, continuous-wave transmitter.

"Your game is up, Dandy Diavolo!" cried Harold Dare. The villain whirled—to face a sinister row of blue-muzzled automatics. He raised his hands skyward.

"Am I undone?" he demanded. "Is this like another scenario, in which right always triumphs in the last reel, and the villain finds himself thoroughly foiled? Am I doomed to disappointment even in this story also? Is this the last episode?"

"Yes," said Harold Dare, "you are foiled; for, as in a scenario, you must be foiled in the last reel, and this is

THE END."



## Radio Takes Over the Geography Class

(Continued from page 1317)

This brings us to another point. Between any place in the world and any other one, there are many paths on the face of the earth; but one is shortest—a "great-circle" path. This is presumably the course of a radio signal; though recent tests with automatic recording devices show that the signal from a high-power non-directional transmitter arrives also the longer way round, a very slight fraction of a second after the first impulse.

But between two points exactly opposite on the earth all paths are of equal length; and consequently the whole unabsorbed energy of a radio wave from one would converge on the receiving antenna at the other. The effect of fading would, however, be noticeable; as some portions of the wave would be reflected at different levels in the atmosphere. All in all, however, it seems reasonable that there should be an effect something like that observed in the well-known "whispering galleries;" where a sound created at one particular point in the auditorium is reflected with full force from every wall upon one other spot.

Excellent reception has been noted, in Australia, of signals, particularly short-wave ones, from England and the United States, and vice versa—this is notable when the extremely low power used is considered. This suggests the possibility of some very interesting researches into radio.

What will be the result if we try sending radio messages between two "antipodal" points, as far apart as it is possible to separate two places in this world—about 12,400 miles? Will we find that signal strength suddenly jumps up as we approach the point of greatest distance? The only sure, and scientific way to learn is to try the experiment and see what happens.

### AMAZING STORIES

IN OUR JUNE ISSUE

**The Invisible Man**, by H. G. Wells. While there have been many battles fought in our Discussions Department as to certain of Wells' stories, the editor makes the prediction that *The Invisible Man* will be acclaimed by all the readers of AMAZING STORIES. It is one of those stories that is well nigh perfect.

**The Blue Dimension**, by Francis Flagg. Of course, you will remember Mr. Flagg's past stories, *The Master Aits* and *The Machine Man of Ardabia*. In *The Blue Dimension*, he has produced a real thriller, and it is a most convincing story, too.

**The Golden Girl of Nunan**, by Earl Vincent. What a very few scientists, exiled with a small group of radicals, finally invent on a small island off in the uncharted seas, is graphically told by our new author, who has not only a vivid imagination but, (being an engineer of high standing) an adequate amount of scientific knowledge from which to draw.

**Baron Münchhausen's Scientific Adventures**, by Hugo Gernsback. Our friend, the Baron, having a knack for learning everything worth-while knowing, continues, in his own manner, to tell us about the cities of Mars and how the planets look, as seen through the powerful Martian telescopes. He also advances an entirely new theory, as to how the Martians might make life bearable on their desolate planet.

And Others.

# New SUPER MACK SPRING AERIAL

TYPE No 20 - \$4.00

EASY TO ERECT

No. 20 for a 20 to 60-foot stretch  
No. 60 for a 60 to 126-foot stretch  
Aerials contain 350 feet of coiled wire

TYPE No 60 - \$2.50

LATEST AND GREATEST IMPROVEMENT IN AERIALS FOR ALL SETS

Guaranteed to Improve Distance Reception Any in Locality

One of these aerials erected in place of your old aerial will give your set greater volume, proportionate to selectivity. This means your set will give a CLEARER, FULLER and LOUDER reception on stations you have been able to receive, and will bring in stations from longer distances, likewise different directions than you have had before.

THOUSANDS SOLD AND NOT ONE DISSATISFIED CUSTOMER

If your dealer cannot supply you—order direct—give number and send check or money order. Mack Aerial Hour—Station WLIT—Wednesday A. M., 11 to 12 noon

MACK CO., Inc., 44 N. 4th St., Dept. J. Philadelphia, Pa.

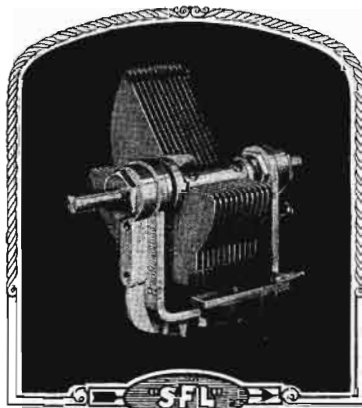

Write for Folder

HAMMARLUND MFG. CO.  
424-438 W. 33rd St., New York

Canadian Representative

WHITE RADIO COMPANY, Ltd.  
41 West Ave. N., Hamilton, Ont.

## For Those Who Prefer Straight-Frequency-Line Condensers

The Hammarlund S-F-L Condenser stands at the head of its class—as popular as ever with fans and experimenters who prefer the exclusive advantages of that type.

It is *Hammarlund Quality* throughout, embodying every modern constructional feature of its famous companion, the Hammarlund Mid-line Condenser—only the tuning curve differs.

If your dealer can't supply you, write direct to us.

For Better Radio  
**Hammarlund**  
PRECISION PRODUCTS



**FREE** WHOLESALE RADIO CATALOGUE  
*The Book they are all talking about*

**WHOLESALE RADIO CATALOG**

Listing thousands of items in standard radio parts. Kits, Accessories, Complete Sets, Furniture, etc. Every Set Builder and dealer should have a copy. Real wholesale prices. Send for your copy today.

**THE HARCO COMPANY**  
1257 So. Wabash Ave. Chicago, Ill.

*The HARCO CO. 1257 So. Wabash Ave. Chicago*

**NEW SHIELDED SUPER-10**

5 Screen Grid R. F. Amplifiers  
4 Stage Power A. F. Amplifier  
*Illustrated literature gratis*  
Complete Constructional Blue Prints, \$2.00, postpaid

**NORDEN-HAUCK, INC.**  
*Builders of Highest Class Radio Apparatus in the World*  
Marine Bldg., Philadelphia, Pa.  
Cable Address "NORHAUCK"

**\$21 WARREN**

For 1 to 10 tubes. Complete with tube. Guaranteed. Was \$35. Now DIRECT to you. \$21.00. Write

**WARREN ELECTRIC CO., Dept. R.N., Peoria, Ill**

Quality Apparatus

Our latest bulletin No. 929 describing our complete line of quality apparatus is yours for the asking. Write for it today.

**GENERAL RADIO CO.**  
30 State St., Cambridge, Mass.

# Build THE STROBODYNE

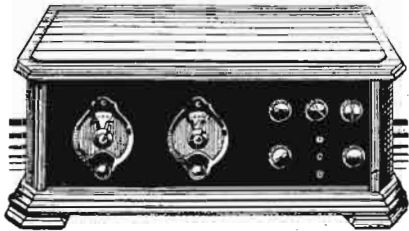

## The Greatest Super Heterodyne

A NEW and revolutionary principle is embodied in the Strobodyne. This new principle is based on what is known as the "Stroboscopic Phenomenon." It is the application of this phenomenon to the basic principles of Super-Heterodyne construction that has placed the STROBODYNE so far ahead of all other Super-Heterodynes. The STROBODYNE employs eight tubes and is a marvel from the standpoint of selectivity, accurate tone reproduction and as a DX set.

Of course CONSRAD, the oldest and original radio pattern publishers, were given the task of publishing complete instructions for the building of an efficient STROBODYNE RECEIVER. In designing the best and most comprehensive instruction material, they have excelled. The STROBODYNE PATTERN BY CONSRAD contains four full size blueprints and a special 16-page instruction booklet that answers fully every question on STROBODYNE construction.

Write today—Get a full set of STROBODYNE patterns from CONSRAD—You will be more than satisfied with the results that a STROBODYNE RECEIVER assures you.

Full constructional data

only **50c**

THE CONSRAD CO., Inc.  
230 FIFTH AVE., NEW YORK, N. Y.

THE CONSRAD CO., INC.,  
230 Fifth Ave., New York, N. Y.

Gentlemen: Kindly send me a full set of blueprints and all data required for building the efficient STROBODYNE RECEIVER. Enclosed find 50c. to cover

Name.....

Address.....

City.....State.....

### THE "ANTIPODES"

Unfortunately, there are comparatively few points on land directly opposite each other; as about three fourths of the earth's surface is water, and a considerable portion of the land is rather unpleasant as a habitation. The United States, for instance, is opposite the Indian Ocean (not China!) and its three million square miles of land is counterbalanced by nearly six times as much water.

Nevertheless, in this vast area of brine, there are two small islands, which seem ideally fitted by geography, if not by scenery, for a radio observation post. Suppose that on Amsterdam Island there is placed a competent party of radio observers, with ample equipment, and in the southeast corner of the state of Colorado a suitably-powerful short-wave transmitter is set up.

A vertical wave broadcast from this aerial in the United States will radiate in every direction; but if it continued its course concentrically, with each impulse in the line of the original motion, theoretically every one would arrive with practically the same force at the same time on Amsterdam Island, as though an aerial 78,000 miles long surrounded the transmitter. As a matter of fact, because of the varying reflection of the wave, and the slight irregularity of the earth's surface, it is not possible to predict exactly the result. That would have to be found out by experiment; but it would be worth while to know what would happen.

We may try aerials erected at all angles; peculiar grounds, sunk vertically into the earth, etc. We may determine in what direction a wave, projected from a vertical aerial, arrives at its journey's end. We must experiment with several different wavelengths, to determine which will be reflected most precisely from the transmitter to the receiver over this distance; for different waves have different "skip distances." (Fig. 2.)

Offhand, the reader might suppose that the radio wave would pass directly through the earth; from one vertical aerial to another exactly in line with it through the center of the globe, instead of going around, nearly 5,000 miles further. The fact is, however, that the principal part of the radio wave, at least at high frequencies, seems to be reflected from the earth to the atmosphere and back again. The center of the earth appears to be an effective magnetic screen, and the presumption is strongly supported, that the earth's core is composed of iron and other metals. (See Radio News for February, 1927, "Can We Radio the Planets?") Yet some waves arrive through the ground, or at least at its surface. Experiment and tests at the antipodes should add a great deal to our knowledge of long-distance radio communication, and of the method of the propagation of waves.

If these experiments prove successful, and the most suitable frequencies for short-wave communication at a distance of 12,500 miles are determined and made available for research work, an even more interesting line of investigation presents itself.

We have indicated in Fig. 1 the general distorted appearance of a very peculiar form of map; one which specializes in giving the distances of points on the earth from one central place of beginning. It is very much like any ordinary map at the center; but after we get about 6,200 miles from the place where we start, a very re-

markable distortion commences, exaggerating more and more the widths of countries near the opposite side of the earth; just as the Mercator map does the areas near the poles. The rim of Fig. 1 is one point; one point opposite the center of the map, and 12,400 miles straight away from it in any direction—east, west, north or south. This shows, not only what we have just said—that all parts of the radio wave will be concentrated again upon the "antipodes" of the transmitter—but also that, if we use a beam transmitter, it will bear upon our antipodal point, no matter in what direction it is turned. (See Fig. 2.)

### SCANNING THE WHOLE WORLD

Now then, suppose that we have in Prowers County, Colorado, a short-wave beam transmitter of fairly high power—several kilowatts; and that we have on Amsterdam Island a receiver connected to a somewhat similar apparatus, which will greatly strengthen its pick-up in the line of its focus. Each aerial is mounted on a turntable (See page 947 of RADIO NEWS for February, 1927, above cited) like the revolving radio lighthouses; and, at a given time, both are started revolving synchronously. At the receiving end we have an automatic register, which notes on a permanent record sheet the strength and time of the signals.

Distance and strength of the transmissions are uniform; the strength of the reception will vary according to the conditions met in its path by the wave. Revolving the two aerials, a world's width apart, in step through 360 degrees will measure the loss undergone by the wave, in every distinct path it can take on the earth's surface.

It is true that there can be expected no immediate and revolutionary discovery. These observations will have to be taken regularly over a long period, until there is obtained an average value for reception strength along each line of transmission; compensated for seasons of the year, for time of the day, for solar variations, for weather conditions. Then each observation will mean something as to the effect of daily changes; just as the average strength of reception through a certain direction will mean something about the absorptive power of the earth itself in that plane.

Adding to our proposed plan for measuring the radio characteristics of the globe (since it costs nothing for imagination) we may conceive two more similar pairs of transmitters; each of which will be at a distance of exactly 90 degrees or one-fourth of the earth's circumference, from the original pair. The revolving beams of these will intersect each of the others in their sweep; and calculations from the tables of observations will determine what part of the effects experienced by each radio beam is due to the conditions at the point of their intersection. (Fig. 3.)

For instance, it is now well known that a violent storm is a cause of static. The center of the magnetic disturbance is at the center of the storm. The radio observatories will be able to "triangulate" a violent storm at either pole, or in any of the other vast wastes from which our bad weather comes; to measure the effect of sunspots and solar storms on the atmosphere, and thus make possible long-range weather predictions for weeks ahead.

Are the "freaks of reception," often noticed, due to the mineral contents of the earth beneath the receivers in locations most

highly favored? What is the relation of the earth's magnetic poles to its metallic contents? Can seismic disturbances (earthquakes) be analyzed by a study of their magnetic accompaniments? All these things, perhaps, may be answered by the observers at the radio research stations which we have here anticipated.

At the same time, these transmissions will be of use for other purposes. The future navigator or explorer will have a "radio almanac" rather than a "nautical almanac." Instead of leveling his sextant at the stars, he will set his short-wave receiver to pick up the revolving beams as they sweep over his course; determine the time, triangulate his position. Even now the "geodesists" are looking to the use of radio to determine more closely than ever before boundaries and other positions on the earth. A chronometer must vary slightly; but by radio, with automatic recording devices, the distance between two points may be determined to the extreme of astronomical accuracy; perhaps even a foot or two at several thousand miles.

Some time ago there was reproduced in the pages of Radio News—with an illustration by a staff artist—the suggestion from a British contemporary that revolving-beam transmitters might be erected at the poles for the purpose of covering the earth with radio programs in one endless sweep. It was not intended seriously; and the North Pole, at least, being in an ocean covered with drifting ice, is not a suitable place for a permanent installation. However, as accompanying maps and pictures show, antipodal beam transmitters are quite practical for purposes of research; and the principal problem to be solved (next to the financial one) is that of selecting suitable antipodal points in the comparatively-limited areas on the globe available for work of this kind.

## Developing a Horn's Possibilities

(Continued from page 1343)

### PRINCIPLES OF HORN DESIGN

The layout dimensions which have been printed in this, and other articles on exponential horns, undoubtedly must appear to many of our readers to have been taken at random; but the relation of these odd figures is very simple to those familiar with the curve laid out by means of such measurements. To calculate these dimensions, however, is a matter of no small difficulty without the aid of logarithmic tables; and, for this reason, we give below figures which will enable any reader, with a very little simple arithmetic, to design an exponential horn of any size whose construction he is willing to undertake.

The figures below may be used for either a square or a round horn. The latter, if perfectly constructed, would have several advantages, including strength, economy of material, less reflecting surface, etc.; but it presents serious problems to the worker in most materials available.

First, however, how ambitious is our energetic reader? He wishes a perfect horn; one that will amplify, or more correctly, least suppress, any audible note. It can be constructed; a picture of such a

### California Man Has a Talk With MacMillan in the Arctic

LONG BEACH, Cal., Oct. 5 (AP).—Radio communication with the Donald B. MacMillan expedition in the Arctic was established here last night by Don C. Wallace, an amateur. Wallace picked up WMP, the MacMillan station, and exchanged numerous messages with G. E. Himoe, the expedition operator.

The expedition is preparing to dig in for the Winter, Himoe said. Snow began falling yesterday just as members of the party finished shingling the roof of their quar-

### JERSEY AGAIN PICKS UP MACMILLAN WIRELESS

Expedition Now in Its Winter Quarters, Radio Operator Tells Absecon Amateur.

Special to The New York Times. ATLANTIC CITY, N. J., Nov. 26.—A ten-minute conversation with the MacMillan Arctic expedition was reported by Emerson T. Showell, 204 year-old amateur radio operator, from Absecon today. Showell was transmitting over a set of seven and one-half watts output, a twenty-meter wave length and an inside aerial. He spoke with Arctic Circle operator short-

The MacMillan Expedition is equipped with "ESCO" Motor Generators.

### ELECTRIC SPECIALTY COMPANY

Trade "ESCO" Mark

211 South Street

Stamford, Conn., U. S. A.

Makers of Motor Generators and Dynamotors with the least ripple and the most miles per watt.

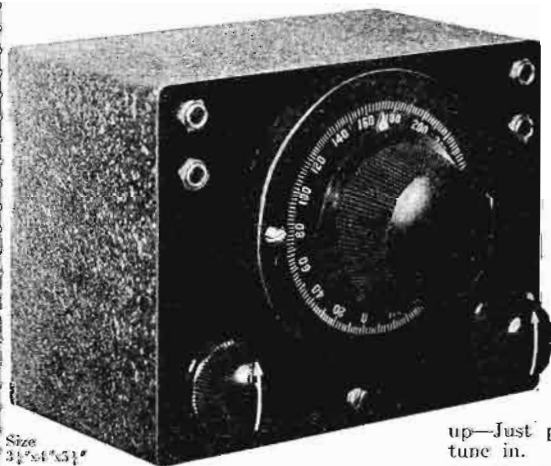

PHOTOGRAPH

1 Actual  
2 Size

OPERATES ENTIRELY FROM ONE STANDARD 4 1/2 VOLT "C" BATTERY CONTAINED IN THE CABINET

Receives 1000 to 1500 Miles

Take it with you when traveling—No aerial to put up—Just plug in a light socket and tune in.

## THE CUMMINGS SOLODYNE

AN AMAZING LITTLE ONE-TUBE RECEIVER WITH EXCEPTIONAL RANGE AND VOLUME

This astounding little set, located in Wichita Falls, Texas, receiving from a light socket, picked up Chicago stations nightly for six months, and in July received Havana, East Pittsburgh, Los Angeles, and four stations in Florida.

Complete, with "C" Battery, Type UX199 Tube, Dubilier Light Socket Antenna, and pair of Frost Phones, designed especially for this set—\$15.00. Less Antenna, Tube, and "C" Battery... \$12.50

CUMMINGS RADIO CORPORATION, P. O. Box 755, South Side Station, Springfield, Missouri.

## \$1 SAVES YOUR SPEAKER

The Craftsman Dollar Speaker Filter is Guaranteed to relieve your speaker of the DC plate current (up to 250 volts). It gives speaker a chance to operate at its best. Attached in a second. Complete protection for one dollar, postpaid.

Send Dollar Bill NOW!

CRAFTSMAN RADIO PRODUCTS

9 ORCHARD ST., NEWARK, N. J.



**JEWELL WRITE**  
For Our 32 Page  
**Radio Instrument Catalog**  
No. 15-C  
**JEWELL ELECTRICAL INSTRUMENT CO.**  
1650 Walnut St. Chicago

**HOOK-UP BOOK FREE**  
Improve your reception with  
**CARBORUNDUM**  
Stabilizing Detector Units,  
Grid Leaks and Resistors  
**THE CARBORUNDUM COMPANY**  
DEPT. D-1, NIAGARA FALLS, N. Y.

# SUCCESS

## From

"Since my graduation from your school in 1924 I have been going ahead steadily. I was first assistant to Dr. Barnett of Stanford University, doing private research work. This year I was promoted to official technician for the Stanford Service in San Francisco Hospital." (Signed) M. S. Llano.

"I got the job! Three and one-half hours after your recommendation must have reached Mr. A—I was called in to his office and promoted over heads of at least twelve men." (Signed) J. J. Kelly.

"I am now cleaner and dyer for the above-named company, and I believe that the course which I am taking with you is the cause of my getting this place. My salary is almost double what it was when I started with the course." (Signed) E. H. Lasater.

"I thought I would write and let you know of my success. I now have a fine position as chemist at Du Pont's Dye Works. It was through your course alone that I have been so successful." (Signed) B. G. Bennett.

# CHEMISTRY

## NOW Is the Time to Study Chemistry

Not only are there boundless opportunities for amassing wealth in Chemistry, but the profession affords congenial employment at good salaries to hundreds of thousands who merely follow out its present applications. These applications are innumerable, touching intimately every business and every product in the world. The work of the chemist can hardly be called work at all. It is the keenest and most enjoyable kind of pleasure. The days in a chemical laboratory are filled with thrilling and delightful experimentation, with the alluring prospect of a discovery that may spell fortune always at hand to spur your enthusiasm.

## Easy Monthly Payments

You don't have to have even the small price of the course to start. You can pay for it in small monthly amounts—so small that you won't feel them. The cost of our course is very low, and includes everything, even the chemistry outfit—there are no extras to buy with our course. Our plan of monthly payments places a chemical education within the reach of everyone. Write us and let us explain our plan in full—give us the opportunity of showing you how you can qualify for a highly trained technical position without even giving up your present employment.

CHEMISTRY has no equal as a profession in the modern world. There is mystery, romance, and fortune awaiting the man in the laboratory.

Millions have been made by the discoverers of the chemical formula of dynamite, bakelite, and many other world-known chemical products.

Opportunities in the chemical profession abound on every hand—and as modern business and competition progresses the chemist will play an important part.

Profit by the experience of Mr. Kelly and many others; resolve to study chemistry NOW.

## YOU CAN LEARN AT HOME

To qualify for this remarkable calling requires careful specialized training. Formerly it was necessary to attend a university for several years to acquire that training, but thanks to our highly perfected and thorough system of instruction, you can now stay at home, keep your position, and let us educate you in Chemistry during your spare time. Even with only common schooling you can take our course and equip yourself for immediate practical work in a chemical laboratory. Dr. Sloane gives every one of his students the same careful, personal supervision that made him celebrated throughout his long

career as a college professor. Your instruction from the very beginning is made interesting and practical, and we supply you with apparatus and chemicals for performing the fascinating analyses and experimental work that play such a large part in our method of teaching, and you are awarded the Institute's official diploma after you have satisfactorily completed the course.



T. O'CONOR SLOANE,  
A.B., A.M., LL.D., Ph.D.

Noted Instructor, Lecturer and Author. Formerly Treasurer American Chemical Society and a practical chemist with many well known achievements to his credit. Not only has Dr. Sloane taught chemistry for years, but he was for many years engaged in commercial chemical work.

## GOOD CHEMISTS COMMAND HIGH SALARIES

### MAIL COUPON FOR FREE BOOK

Your name and address on the coupon will bring you by return mail our interesting free book, "OPPORTUNITIES FOR CHEMISTS," and full particulars about the course and what it will do for you. You owe it to yourself to get this book. Send the coupon right now while it is fresh in your mind. Or just write your name and address on a postal and mail to us. But whatever you do, act today.

**DON'T WAIT—MAIL COUPON NOW!**



## EXPERIMENTAL EQUIPMENT FURNISHED TO EVERY STUDENT

We give to every student, without additional charge, this chemical equipment, including fifty-two pieces of laboratory apparatus and supplies, and fifty-two different chemicals and reagents. These comprise the apparatus and chemicals used for the experimental work of the course. The fitted heavy wooden box serves not only as a case for the outfit but also as a useful laboratory accessory for performing countless experiments.

## Chemical Institute of New York, Inc.

Home Extension  
Division 6  
16-R-East 30th St.  
New York, N. Y.

CHEMICAL INSTITUTE OF NEW YORK, INC.  
Home Extension Division 6  
16-18-R—East 30th Street, New York, N. Y.

Please send me at once, without any obligation on my part, your free book, "Opportunities for Chemists," and full particulars about the Experimental Equipment given to every student. Also please tell me about your plan of payment.

NAME.....

ADDRESS.....

CITY.....STATE.....

horn appears on page 1135 of RADIO NEWS for April.

#### ARE YOU AMBITIOUS?

It is considered that 16 cycles is about the lowest audible note; some great organs have a pipe capable of delivering such a tone—but it is felt rather than heard. A 16-cycle exponential horn will be 15 feet  $6\frac{1}{8}$  inches square at the bell. If we start building it at a  $\frac{5}{8}$ -inch neck, as our constructors of parlor horns have done, it will be 65 feet 8 inches long. But such a horn will require a power amplifier of uncommon size actuating a diaphragm of heroic proportions to pump into it the air necessary to sustain its deepest notes at full volume. If the driving surface of the unit were to be 7 inches square, we could take no less than 28 feet off the horn. This would reduce it to such comfortable proportions that it could be used as a garage and workshop, while not otherwise employed.

On the other hand, if we were content with a 512-cycle horn, a bell of less than 6 inches square and a length of 10 inches would serve our purpose. A few years ago radio fans were quite happy with the reproduction they obtained from horns of about this size and appearance. And it was not observed by them that notes of less than 500 cycles were inaudible, even if the reproduction seemed a trifle high-pitched. Why?

The answer is that the expression "a cut-off frequency" is a trifle misleading. While the short horn does not concentrate these notes with the same efficiency as the longer one, they will be heard to some extent, if they are reproduced with sufficient energy by the speaker unit. In fact, low notes may be heard from headphones which have no horn at all.

The lowest note of the piano is 26  $\frac{2}{3}$  cycles; a horn designed for this, as its lowest frequency of response, would be 9 feet 3  $\frac{2}{3}$  inches square and 31 feet 2  $\frac{1}{4}$  inches long. If we fitted it with a dynamic speaker unit of 25 square inches surface, we could reduce this length to 16 feet 9  $\frac{1}{4}$  inches. A 32-cycle horn would be a trifle smaller. But, though at least one of our readers has built 20-foot horns, it is probable that the demand for them will be small—at least for home use.

It is probable that the constructors will be best suited by an instrument designed for between 64 cycles and 128 cycles. The former will be about 46  $\frac{1}{2}$  inches square at the mouth and 12 feet 5 inches long; the latter 23  $\frac{1}{4}$  inches square and 5 feet 2  $\frac{1}{2}$  inches long. To increase the fundamental frequency of a horn shortens its wavelength—just as in an R.F. circuit. When a horn's wavelength is cut in two, the diameter of its bell may be cut in two, and its length shortened more than half.

#### HOW TO FIGURE IT

It is necessary, as the figures above show, to make some compromise with our ideals; and this will be done the more willingly when it is remembered that to have perfect fidelity of reproduction, we would need 100% efficiency in the R.F. amplifier, the detector, the audio amplifier and the speaker unit, as well as in the design of the horn. The reproduction from a six or eight-foot horn may not be perfect, but the imitation is a good one. It is probable that few listeners indeed could detect any under-

emphasis of the low notes in a 64-cycle horn with a good unit.

The interpretation of the table below is briefly made. These figures represent cross-sections of the horn at short intervals, based upon the *Rate of Expansion* ("RE") for any particular horn; which, in turn, depends upon the particular frequency for which we design it. Let us determine upon this frequency, and divide 768 by the number of cycles in the lowest, or fundamental, note we have determined upon. The result, in inches, is the *Rate of Expansion* ("RE") which determines the distance between the unit cross-sections of our horn—each of which is twice as large in area as the one immediately before it.

Suppose, for an easy example, we take 256 cycles—our old standby, "Middle C." Then the rate of expansion is 3 inches. Our table, made up in dimensions corresponding to every cross-section at distances equal to one-sixth of the rate of expansion, gives us the dimensions of the horn at every half-inch interval. This is more accurate than we need.

Shall we have a square horn? Divide 2978 by our chosen frequency; the result in inches is one side (inside) of the bell of our horn. In our example, this will be found to be 11  $\frac{21}{32}$  inches square. Half-way between 7 and 7  $\frac{1}{6}$  in our table, we find, the required figure will fall. Then 7  $\frac{1}{12}$  times 3, or 2  $\frac{1}{4}$  inches, is the length of the horn from its 1-inch section.

The lower part of the neck, below the 1-inch line, is comparatively straight; if we use a unit with an opening equal to  $\frac{5}{8}$  inch square, the length of this additional section will be equal to 1  $\frac{16}{45}$  times the "RE," or 4  $\frac{1}{16}$  inches for a 256-cycle horn. Total length of horn, 25  $\frac{5}{16}$  inches.

If we decide instead to make a round horn, we divide 3360 by the number of cycles; this gives us the diameter of the circular bell. It will be, therefore, 13  $\frac{1}{8}$  inches for a 256-cycle horn. This will add approximately another inch to the horn's length, as may be seen by consulting the table. Beyond the dimensions thus found for the bell, there is no use in extending the length of the horn; for it will flare so much that it no longer guides the air waves which are emerging.

#### EXPONENTIAL CROSS-SECTIONS

We have given dimensions below to the nearest 64th of an inch; there is no use in giving them more accurately for a reader who is working on coarse material, such as wallboard, with ordinary measuring devices. It must be said again that the dimensions below are *inner* measurements and an allowance must be made for lap; and that no part of the horn should be allowed to bow in and "pinch" the air column.

It will be noted also that, at intervals equal to just twice the rate of expansion, there is a continual doubling of the dimensions in our table. It can be extended indefinitely either way, by the simple process of dividing by two the *twelfth figure below* the desired one, or by multiplying by two the *twelfth figure above*. For instance, the first addition to the table, following "Twelfth Unit," will be twice the figure following after "Tenth Unit;" or 67  $\frac{13}{16}$  inches.

The neck of the horn will constrict to 23/32 of an inch at a distance equal to two "RE" above the "First Unit" in the figures above, and so on; but, as we have

## Centralab Radio Control Box Protects "AC" Tubes from High Line Voltages

ELECTRIC Radio Sets using "AC" tubes are designed to operate on a line pressure of 110 volts. Any high voltage overloads the tubes and greatly shortens their life.

In many cities the normal line pressure runs from 120 to 135 volts. In nearly all cities the voltage fluctuates with the lighting load, and at some period during the day is high enough to damage the delicate tube filaments. That is why tubes lose their pep after short service and why the new Centralab Radio Control Box is an essential and economical accessory for most "AC" set owners.

The Centralab Control Box is a manual line voltage control for "AC" sets. It can be adjusted for any set and for any local condition. It will protect radio tubes from high line voltage that would otherwise soon paralyze or burn them out. It insures longer tube life and better radio reception.

The Centralab Control Box is easily mounted within the cabinet. Adjustment is made by means of a knob, and when once set to obtain the average workable voltage need not be adjusted again. Connected as easily as plating a lamp into a wall socket. Furnished complete with receptacle and cord. No other wiring necessary.

Price \$3.00

At your dealer's, or write us.

CENTRAL RADIO LABORATORIES  
19 Keefe Avenue Milwaukee, Wisconsin



Centralab

## CARTER

### Tube Shield and Shielded Connector

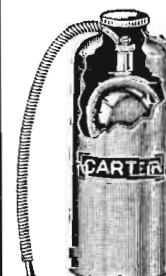

for new 322  
Shielded Grid  
Type Tube

Again Carter is ready for you. Everybody who has tried this Shield is enthusiastic about it. Write for folder giving full information—we'll gladly mail you a copy.

MEMBER  
RMA

Carter Radio Co.  
CHICAGO

## Master the Code

Wireless or Morse—at home with the TELEPLEX Automatic Code Instructor. No better method for self instruction exists. Quick—EASY—Thorough. Endorsed by U.S. Navy. The only instrument that REPRODUCES actual sending—messages, radiograms, etc. ANY speed. Complete Course furnished. Thirty times as many words as any other instrument. Avail yourself of the TELEPLEX for a quick mastery of the code. Write for booklet NR—TELEPLEX CO., 76 Cortlandt St., New York, N. Y.

**Tyrman '70'**  
Shielded Grid Amplifier  
USING SHIELDPLATE TUBES TYPE SP122  
Absolutely New and Different  
The fastest selling kit on the market. Has been acclaimed "America's Greatest Receiving Set" by Radio Engineers, Designers, Editors, and Jobbers. Set Builders have been astounded by the revolutionary performance of this receiver. Write for details or ask your dealer today.  
TYRMAN ELECTRIC CORPORATION  
143 West Austin Avenue Chicago, Ill.

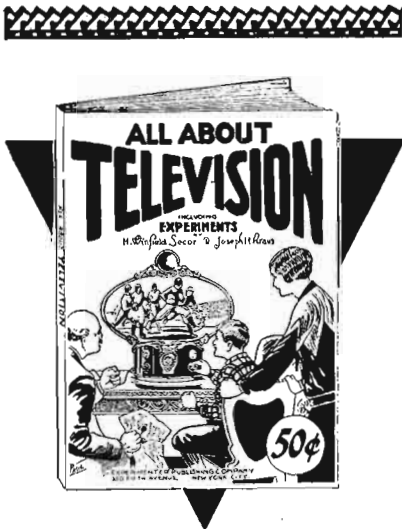

**Begin now!**  
**Build for the future**

The day of perfected Television is fast approaching. Here is a new field—a field in which there is all the glory of accomplishment—all the joy of experimenting that radio, in its infancy, afforded the enthusiastic fan.

Many of the greatest successes of the Radio Industry are the experimenters of the old days. They are the ones who, seeing the future of Radio, and for the joy of developing, devoted their time to experimenting. It is to them that many of the perfections of Radio can be laid.

And in Television there is the same field for those who take advantage of it. Grow with this infant industry, learn all there is to know about Television. Write today—send for "TELEVISION," by H. Winfield Secor and Joseph Kraus. Complete, up-to-date information on everything that has taken place in the field of Television, including all experiments.

**BUILD AN EXPERIMENTAL TELEVISION SET**

Complete instructions for building an experimental set are contained in this remarkable book, "TELEVISION." Use the coupon—Send for "TELEVISION"—this is your opportunity—grasp it. Build now for the future. Learn all about Television. This is a big new field opening up to receive you.

116 pages—fully illustrated—large size 9x12"

AT ALL NEWSSTANDS  
 or  
 WRITE DIRECT

THE **50c** COPY

EXPERIMENTER PUBLISHING CO.  
 230 FIFTH AVENUE NEW YORK N. Y.

EXPERIMENTER PUBLISHING CO.  
 230 Fifth Avenue, New York, N. Y.

Gentlemen:  
 Enclosed find 50c. for which kindly send me your remarkable book, "TELEVISION."  
 Name.....  
 Address.....  
 City.....State.....

said, at this part of the horn the lines curve so little that it is not worth while to endeavor to make delicate calculations or measurements.

Length in R. R. Units	Cross Section	Length in R. R. Units	Cross Section
Start.....	1	6th Section.....	8
1.....	1 1/16	1/6.....	8 15/32
1.....	1 1/8	1/5.....	8 9/16
1/2.....	1 2/16	1/2.....	9 29/64
2/3.....	1 3/16	2/3.....	10 5/16
1.....	1 1/2	2/3.....	10 5/16
1st Unit (1 R.E.).....	1 29/64	7th Unit (7 R.E.).....	11 5/16
1/2.....	1 1/2	1/6.....	11 5/16
1/3.....	1 29/64	1/3.....	12 49/64
1/2.....	1 11/16	1/2.....	13 29/64
1.....	1 29/32	2/3.....	14 1/4
2.....	2 9/64	2/3.....	15 3/4
2nd Unit (2 R.E.).....	2 29/64	3/4.....	16 49/64
1.....	2 1/8	1/2.....	17 49/64
1/2.....	2 3/8	1/2.....	19 1/32
2/3.....	2 37/64	2/3.....	20 11/64
3/4.....	2 49/64	3/4.....	21 29/64
5th Unit (5 R.E.).....	2 59/64	3/4.....	22 9/8
1/2.....	3	1/6.....	23 31/32
1/3.....	3 11/64	1/3.....	25 29/64
1/2.....	3 29/64	1/2.....	26 29/32
2/3.....	3 9/16	2/3.....	28 5/64
3/4.....	3 49/64	3/4.....	30 9/64
4th Unit.....	4	10th Unit (10 R.E.).....	32
1.....	4 7/32	1/6.....	33 29/32
1/2.....	4 31/64	1/3.....	35 29/64
1/2.....	4 3/4	1/2.....	38 29/64
2/3.....	5 3/64	2/3.....	40 19/16
3/4.....	5 13/32	3/4.....	42 19/64
5th Unit (5 R.E.).....	5 29/64	3/4.....	45 1/2
1.....	5 29/32	1/6.....	47 31/32
1/2.....	6 3/8	1/3.....	50 29/64
1/2.....	6 49/64	1/2.....	53 17/16
2/3.....	7 1/8	2/3.....	57 1/64
3/4.....	7 17/32	3/4.....	60 9/32
6th Unit (6 R.E.).....	8	12th Unit (12 R.E.).....	64

**Radio Patents**

(Continued from page 1347)

kept tuned to the desired frequency, and connected electrically to the clock by the closing of a contact just prior to the time of the expected signals. The first dot of the signal closes the relay shown at the lower center; and, from then until the last dash operates to throw a slow-acting relay, the synchronizing circuit is in operation. The action of the relay impulses upon the clock then depends upon whether it is ahead of or behind the time indicated by the time signals; in the former case, the mechanism of the clock is slowed down or

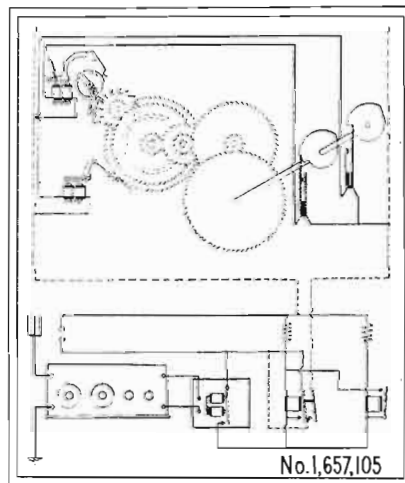

stopped, and in the latter it is accelerated until the clock is brought to correspond with the standard time, if the difference is not too great. Should the clock be seven minutes fast, however, and the synchronizing signals cover only a five-minute period, the clock will simply be stopped for five

minutes; the mechanism will undertake the rest of the correction at the next period of time signals. Either alternating or direct current may be used, for the regulation of a system of clocks.

(Patent No. 1,657,105, issued January 24, 1928.)

**A "Catwhisker" Aerial**

INCREASED area (and presumably capacity) is provided for an aerial by this invention, in which at intervals of, say, fifteen feet are incorporated 12-foot hanging wires, terminating in horizontal radiating groups about a foot in diameter. At intervals of about two feet, lumps of solder or tin are applied to these pendants, as well as to the stranded wires of the aerial itself; and at similar intervals small coils of wire are whipped about the aerial and soldered to it at both ends.

It is explained in the patent by the inventor (not the patent office) that the result is that "the amperage or quantity of the etheric forces are greatly increased and that the quality of the radio signals is much improved over the ordinary form of single or multiple wire antennae. The object of the lumps of solder is to act as a relay and

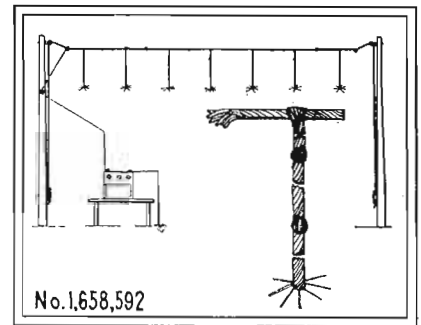

as an accumulator for the oscillating energy from the sending aerial, as also with the small coils." Thus, it is explained, the sensitiveness of the antenna may be increased, though it be installed in the least effective direction. (hi)

(Patent No. 1,658,592 was issued for the above February 7, 1928.)

**Insulation Not Needed**

IT is important that the aerial's lead-in wire be carefully insulated from the side of the building along which it passes, but there is no need for applying the same precautions to the ground wire. The latter is intended to make connection with the ground as thoroughly as possible; and since most houses rest on the ground, any contact the ground wire makes with the building helps matters, if it does anything. However, the value of a good connection at the end, to water pipes, or ground plates buried in damp earth, cannot be overestimated.

**STYLES MUST CHANGE**

FIRST BLONDE: "You never use that cerise tint of rouge that you used to like so well."  
 SECOND BLONDE: "Oh, that was before television. This pumpkin rouge broadcasts so much better."

# Ground Out Static with SUB-AERIAL

Let Ground Waves Bring You Amazing Distance, Crystal Clear Tone Quality, and Greater Volume and Selectivity without Distortion.

Sub-Aerial has brought a new epoch in Radio. No need longer to bother with troublesome overhead aerials. Why risk breaking your neck to put up roof aerials only to have the first storm blow them down? Forget your aerial troubles. Why not use the whole earth as a static and noise filter with Sub-Aerial? Costs no more than an overhead or loop aerial and less than many. Hook your set on to the newly-discovered Ground Waves that bring practically static free reception. Don't stand for the squawks and tin pan reception you get from Air Waves when you can step right out and leave that stuff.

If you don't believe us, try it yourself. If you do not find we're right—absolutely right—you don't pay us a cent for the test.

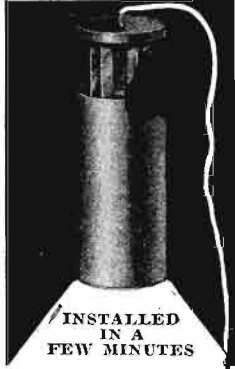

INSTALLED IN A FEW MINUTES

## TRY IT FREE

We know so well the surprising results you'll get that we'll let you put in a Sub-Aerial entirely at Our Risk. Don't take down your overhead Aerial. Pick a summer night when static and noise interference on your old aerial are "Just Terrible." If Sub-Aerial doesn't Sell Itself to You Right Then on Performance—you needn't pay us a cent. Send the coupon for "all the Dope on Sub-Aerial." You'll be surprised. Do it NOW.

UNDERGROUND AERIAL SYSTEMS  
St. Clair Bldg., Dept. 9-H  
cor. St. Clair & Erie Sts., Chicago, Ill.

## Mail the Coupon.

Underground Aerial Systems, Dept. 9-H,  
St. Clair Bldg., cor. St. Clair & Erie Sts.,  
Chicago, Ill.  
Send me complete information on Sub-Aerial,  
Proof and Free Trial Offer. No obligation.

Name .....

Address .....

City ..... State .....

### FREE RADIO CATALOGUE

To Dealers—New, illustrated 1928 Wholesale Radio Catalog gives lowest prices on accessories, kits, packs, parts and sets. Features master-built single control radio sets for both battery and all-electric operation. Full showing of "A" and "B" Eliminators and thousands of other great values. Write on business letter-head for this free book today.

**HAMILTON-CARR RADIO CORPORATION**  
711 West Lake St., Dept. 396, Chicago, Ill.

### A-C FILAMENT TRANSFORMER

Supplies stepped down current from **ONLY \$4.87**  
110 volt 50-60 cycle lines for six type  
226 tubes, two type 227 tubes, and two type 171  
tubes. Guaranteed. Only \$4.87. Order today. Money  
back if not satisfied.

Illinois Transformer Co. 223 W. Elm St.  
Dept. 103, Chicago

## AMRAD

MERSHON CONDENSERS  
For full information address Department RN,  
THE AMRAD CORPORATION  
Medford Hillside Massachusetts

## Radio Measures Human Nerve Impulses

(Continued from page 1331)

becomes disconnected; but while it is running at a high rate the spectator sees a continuous-action fast picture. And so it is with the dull person; he has to retain pictures or images in his mind until they are no longer sharp or clear, in order to associate them with some other idea or thought.

Another application of the apparatus is that of determining the time of arrival of the nerve impulse in the two arms, in order to investigate the causes for stuttering.

Dr. Lee E. Travis, director of the speech clinic at the University of Iowa, has used this method of approach to determine whether "cerebral" (upper-brain) dominance could be relied upon in determining whether a stutterer should be right- or left-handed. The results obtained seem to indicate that this method is very reliable.

While it is impossible to describe here completely the problems involved in the development of this apparatus, as well as the highly technical problems which may be solved with it, the writer believes that many radio fans are interested in this type of experiment and can appreciate partially, at least, the possibilities which present themselves in using the vacuum tube as a tool for research investigation.

(Sounds of the writer's nerve currents, thus picked up, were broadcast on April 15 through the Iowa University station, WSIU—Editor.)

See paper by Dr. Lee E. Travis: Science, Vol. LXXVII, No. 1724, pages 41-43.

## The Electric Brain

(Continued from page 1327)

removed from the position shown, the speech in the large horn dies away and once more the gibberish is heard. In other words, there has been invented an "electrical brain" that understands a language we cannot, and which can translate this language into English.

As mentioned previously, the same operation can be performed on music. However, in that case, the modulating frequencies must be changed, because the range of musical frequencies greatly exceeds that of the voice by several thousand cycles.

## A Real Radio Hound

(Continued from page 1314)

sage of his composition at the same time, and the dog obediently began to bark with the music.

"By gosh! You win!" the stranger exclaimed. "I'd recognize his bark anywhere. That's just the way he sounded over the radio!"

All of which goes to prove that "radio hound" is something more than a hit of vernacular, at least in the case of Mike, J. Henry Fillmore's broadcasting dog.

## FROST-RADIO

### ANNOUNCEMENT

At the Radio Trade Show in Chicago the week of June 11 Frost-Radio will announce a new and improved line of Quality Parts. This new line will be well worth waiting for. Descriptive literature will be ready for release on or before the opening of the Show. Have us place your name on our list to receive this literature. Write us about it today, using coupon below. Our two famous booklets, "What Set Shall I Build?" and "For Better Reception" will be sent you immediately, the other literature to follow.

HERBERT H. FROST, INC.

Main Offices and Factory:  
Elkhart, Ind.

Chicago New York City

HERBERT H. FROST, Inc.  
160 North LaSalle Street, Chicago, Ill.  
Please send me at once your two free booklets "What Set Shall I Build?" and "For Better Reception," and also place my name on your mailing list to receive your new literature, when ready.

Name.....  
Street Address.....  
City.....State.....

## M&H

Radio's largest kit supply house

ESTABLISHED 30 YEARS

We Have Complete Kits For All Circuits

Now appearing or which have appeared in "Radio News" and other publications.

### SET BUILDERS

It will pay you to send for our  
Circuit Booklet and Catalog

Our excellent facilities, together with our technical staff, assures satisfaction.

M. & H. Sporting Goods Co.  
512 Market Street Philadelphia, Pa.

## DYNATONE

ELECTROMAGNETIC POWER SPEAKER UNIT

Operates on "A" Battery For Combs, Bass Wood, Airplane Cloth, etc.

Sent C. O. D. under 10-day money back guarantee. Write for literature.

Unit only.....\$12.50  
Unit and 12-inch Cone.....\$15.00  
Unit, Cone, and Baffle.....\$18.50

FANSPEAKER RADIO COMPANY  
74 Dey Street New York, N. Y.

## STANDARD CLAROSTAT

REG. U. S. PAT. OFFICE

Ask your dealer or send to us direct for literature.  
American Mechanical Laboratories, Inc.  
285 North Sixth Street Brooklyn, N. Y.

Insure your copy reaching you each month. Subscribe to RADIO NEWS—\$2.50 a year. Experimenter Publishing Co., 230 Fifth Avenue, N. Y.

# The RADIO NEWS AMATEURS HANDBOOK

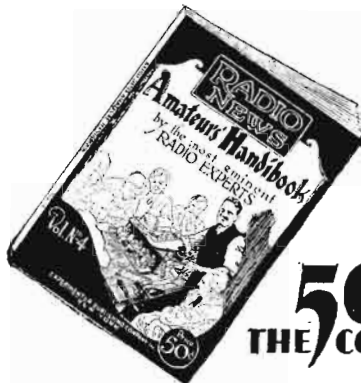

**50¢  
THE COPY**

## for TECHNICAL RADIO FANS

THE RADIO NEWS AMATEURS, HAND BOOK is an invaluable guide and reference book for every radio enthusiast. The most complete work of its kind ever published. Every worthwhile development since the beginning of Radio can be found somewhere within its pages.

Radio Amplification; Audio Amplification; Power Amplification; "A and B" Power Circuits; Electric Sets; Short Wave Transmission and Circuits—each of these important phases of Radio and many others are completely covered in this remarkable book.

Radio Fans, Custom Set Builders, and those studying Radio cannot afford to be without a copy of this complete handbook on Radio.

112 pages—large magazine size  
replete with illustrations

RADIO NEWS AMATEURS HANDBOOK, the most complete chronicle of Radio ever compiled.

**THE 50c COPY**

AT ALL NEWSSTANDS  
OR WRITE DIRECT—

EXPERIMENTER PUBLISHING CO.  
230 Fifth Ave. New York City, N. Y.

EXPERIMENTER PUBLISHING CO.  
230 Fifth Ave., New York City

Gentlemen: Enclosed find 50c., for which kindly send me a copy of the new, up-to-date RADIO NEWS AMATEURS' HANDBOOK.

Name.....  
Address.....  
City..... State.....

# How to Build the Neutroheterodyne

(Continued from page 1341)

- Two mica fixed condensers with grid-leak clips, .00025-nf. (C6 and C7);
- Four adjustable condensers, neutralizing type (C8, C9, C10 and C11);
- Five paper by-pass condensers, 1-mf. (C12, C13, C14, C15 and C16);
- One A.F. transformer, first-stage type (T1)
- One A.F. transformer, second-stage type (T2);
- One grid leak, 5-megohm (R1);
- One grid leak, 2-megohm (R2);
- One rheostat, 20-ohm (R3);
- Five filament ballast units, 201A-type (R5, R6, R7, R8 and R9);
- One filament ballast unit, 199- or 201A-type (R4);
- One filament ballast unit (use proper size for power tube selected) (R10);
- One jack, closed single-circuit type (J1);
- One jack, open single-circuit type (J2);
- One jack, double-circuit filament-control type (J3);
- One battery switch, toggle type (SW);
- One inductor switch, four-contact panel-mounting type (SW1);
- One battery cable and plug, 7-wire type (P);

- Seven binding posts;
- Two vernier dials, illuminated type;
- Seven tube sockets, UX type;
- One front panel, 7 x 21 x 3/16-inch;
- One jack panel, 3 x 4 x 3/16-inch;
- One terminal strip, 1 x 4 x 3/16-inch;
- One baseboard, 10 3/4 x 20 1/2 x 3/8-inch;
- Ten rolls of flexible insulated connection wire in the following colors: white, black, red, green, slate, blue, yellow, brown, salmon and maroon;
- One box of eyelets;
- One bakelite shaft, 1/4-inch diameter, to fit condenser C2;
- Five vacuum tubes, 201A type (V2, V3, V4, V5 and V6);
- One vacuum tube, 199 or 201A type (V1);
- One vacuum tube, 210, 171A or 112 type (V7);
- Two shield cans, 3 1/2 x 5 5/8 x 9 7/8 inches, home-made (S1 and S2);
- Three shield cans, 3 3/4 x 5 1/2 x 6 1/4 inches, home-made (S3, S4 and S5);
- One oscillator coupler, home-made (L1);
- One antenna coupler, home-made (L2);
- Two intermediate-frequency transformers, home-made (L3 and L4);
- One second-detector coil, home-made (L5).

# What's New in Radio

## Double-Action Relay Keeps Battery at Full Charge

THREE systems are now available to the set owner who wishes to operate the filament circuits of his radio receiver with power obtained from the light socket. The first method employs a storage battery, a battery charger and an automatic power-control switch; and the battery is automatically charged while the receiver is not in use. The second system uses an "A" power-supply unit which converts the 110-volt A.C. into pure 6-volt D.C., which may be used for heating the filaments of the tubes. The third way is to use special

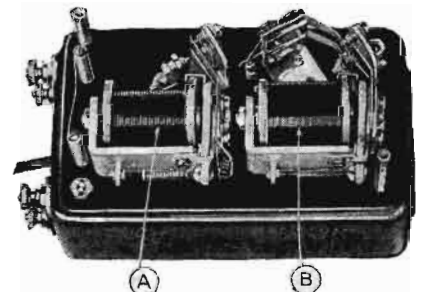

This relay, connected to a full-rate charger, keeps a storage battery fully charged at all times, but will not overcharge the battery.

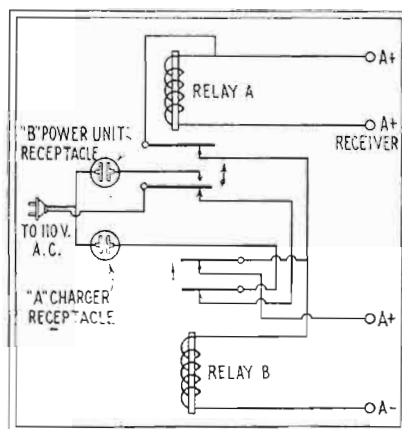

Complete schematic wiring diagram of double-action relay, which turns the charger on when set is not in use, and off when the battery is fully charged.

A.C. tubes, which have electrical characteristics similar to standard tubes, but are designed for operation with a low-voltage source of A.C., which may be obtained from a transformer. It is possible to operate a receiver at high efficiency with any one of these systems; but each has features which render it unsuitable under certain conditions.

In a properly-designed receiver A.C. tubes are capable of giving excellent performance, and the characteristic A.C. hum may be reduced to a very low minimum. However, the receiver must be designed especially for these tubes or, if originally D.C.-operated it must be rewired before these tubes may be used. Also, the characteristics of the A.C. supply must be good, or line noises will be heard in the receiver. "A" power-supply units also give excellent satisfaction; but they necessitate discarding the storage battery and purchasing a unit which is as expensive as a battery and a charger.



As in the case of A.C. tubes, these units may be used only where a good A.C. supply is available.

There are a large number of radio fans, who already own an "A" battery, to whom the use of a charger with an automatic power-control relay strongly appeals; as this is a very inexpensive method of electrifying a receiver. With this system the "trickle" type of charger is most commonly used, and this supplies the battery with current at a very slow rate. In twenty hours, chargers of this type replace approximately the same amount of current that is consumed by the average receiver during an evening's operation. Therefore, where a receiver is used consistently, this method keeps the battery in good condition at all times.

There are also two classes of listeners who wish to use a trickle charger, but find it unsuitable for their needs. The first use the receiver a great deal and, as a result, are constantly discharging the battery; the second class use the set very little and therefore overcharge the battery. This problem may be solved by a new type of power-control relay recently placed on the market. With this relay a full-rate charger is used; the relay turns on the charger when the set is turned off, and turns off the charger when the battery is fully charged. If the set is used a great many hours during the day the full-rate charger is able to bring the battery back to full charge before the set is used the next time. When the set is seldom used, the charger does not operate after the battery has been charged. In other words, the charger keeps the battery fully charged at all times, but never overcharges it. Also, the battery requires practically no attention; as it is necessary only to add water to the cells, at very infrequent intervals.

In construction, the new relay is the same as a previous model, but with an extra coil added. The schematic wiring diagram will be found on page 1382, and shows that the device really comprises two relays, A and B. Relay A, connected in series with the "A" battery lead to the set, causes the "B" power unit to be turned on when the set is in use, and connects the charger when the set is turned off. Relay B is connected in shunt with the battery at all times and turns off the charger when the battery is charged.

### Sets Easily Converted to A.C. with New Kit

A NEW method of electrifying the filaments of the tubes in a radio receiver is illustrated in semi-schematic form in a drawing on this page. A kit consisting of vacuum tubes, a wiring harness, a filament-heating transformer and a volume control is used for the purpose; and it is so designed that most sets may be converted without making any changes in wiring.

The tubes supplied with the kit are of two new A.C. types, incorporating heater-cathode construction, and require 5 volts A.C., supplied by the power transformer; the first is a general-purpose amplifier and the second a special supersensitive detector. The former has an amplification constant of approximately 8, and its electrical characteristics are somewhat similar to those of the standard 201A type. It is used in all radio-frequency and audio-frequency stages of the set.

In mechanical design, the tubes used in this kit are somewhat different from the usual type. The grid and plate elements of the tube are connected to the usual plate and grid terminals in the base, but both filament terminals of the tube are connected to the cathode. Two binding posts are provided at the top of the base, and the wires from the heater element are connected with these.

When converting a receiver from D.C. to A.C. by this system, the tubes are first placed in the sockets of the set, at the same time making sure that the detector tube is used in the detector socket. Next the pairs of free wires of the wiring harness are connected to the binding posts on the bases of the tubes. The terminals at the end of the harness are connected to the two binding posts of the power transformer; and the free wire attached to the power transformer is connected with the "B—" terminal of the plate batteries. To complete converting the set, the volume control is connected in across the aerial and ground binding posts of the receiver.

In operating the receiver after the above changes have been made, the same plate battery or "B" socket-power unit is used;

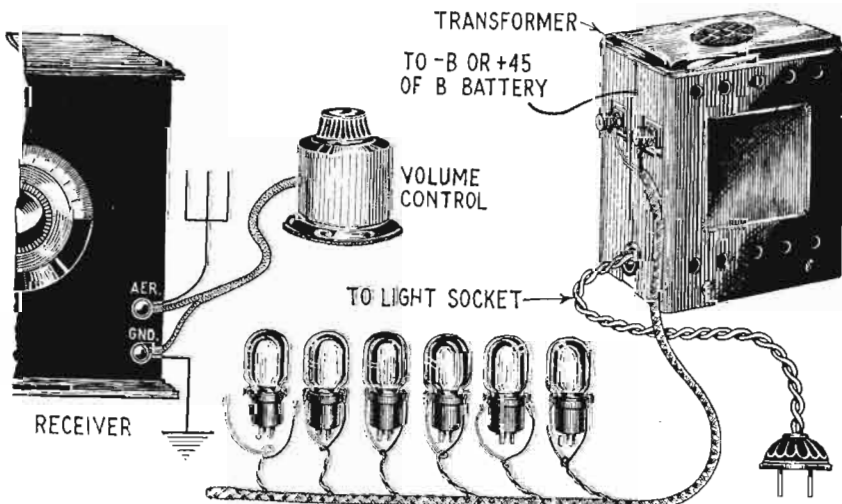

Picture shows method of converting receivers with new kit for operation with alternating current. The kit consists of tubes, wiring harness, transformer and volume control.

## A SENSATION!

Every Object a Loud Speaker  
with the

# HIGH-IDEAL

## OMNIPHONE

Any surface capable of vibration—the top of a table, the glass in a window, the wall of a room—becomes an astonishing loudspeaker with the High-Ideal vibrating tip pressed against it. You've never heard or seen anything like it before! Surprise your friends—take the Omniphone in your pocket wherever you go. Your money back if its reproduction doesn't thrill you! Send coupon.

IDEAL WERKE, 35 W. 33 St., New York, N. Y.

For enclosed \$7.50 please send me one High-Ideal Omniphone. You agree to refund my money if the Omniphone does not satisfy and is returned within ten days.

Name.....  
Address.....  
City..... State.....

## FREE! 30 DAY TRIAL

Powerful 6-7 or 8 Tube Guaranteed RADIO

Radio's most amazing bargains, direct from big, reliable makers (50% discount all year). All Electric or Battery sets. Console or table cabinets. Don't buy unless 30 days trial proves Mexico unbeatable at 2 to 4 times the price for selectivity, distance, volume and rich, Cathedral tone. Turn a dial for all stations. Completely assembled, fully guaranteed sets!

Free literature, users' testimony and BIG SPECIAL OFFER!

**BIG DISCOUNTS to User Agents**

**RETAIL \$36.75 to \$69.75**

**MIDWEST RADIO CORPORATION**  
Pioneer Builders of Sets  
4040 Miraclo Bldg., Cincinnati, O.

## BIG DISCOUNTS TO SET BUILDERS

Big New 1928 Catalog—4000 Bargains—Latest A-C circuits, newest ideas in radio, at startling low prices. The sets and parts you want. Save money. Best parts. Best, complete factory-built sets, supplies. Orders filled same day. Write for free copy. Standard discounts to dealers, set builders, agents. Dept. 306A, Barawik Co., 129 N. Jefferson St., Chicago, U.S.A.

This handy book should go with every Radio!

It is concerned with radio facts—their functions—where they are—and their names. It gives the symbols used in radio book-ups, so that you will be able to read any diagram and understand it. It discusses air waves—the aerial—then takes you through every radio part—and finally the actual reproduction of sound.

This is a book that will give you a full understanding of your set.

**ALL ABOUT RADIO PARTS**  
5 1/2 x 7 3/4 inches, fully illustrated  
Get it from any newsstand or direct

**THE CONRAD COMPANY, INC.**  
230 Fifth Avenue New York City

Insure your copy reaching you each month. Subscribe to RADIO NEWS—\$2.50 a year. Experimenter Publishing Co., 230 Fifth Ave., N. Y. C.

# Says the ~ Boston Globe of Bridge by Whitehead

**PICTORIAL EXPLANATION  
OF AUCTION BRIDGE PLAY**

"New Picture Method Bridge," by Wilbur C. Whitehead—A magazine-like book in which America's foremost bridge expert explains all about the auction bridge game and by pictorial methods explains all about the many fine points involved, particularly the method of bidding and the card values of a hand. For students of the game this illustrated-hand method is a wonderfully clear manner of showing card values for Mr. Whitehead explains just what he would bid on each such hand. He explains about the cut-in-game, "saw game," pivoting, progressive, replay duplicate, progressive duplicate, contract and other bridge games. His pointers about leads and other important features make the volume one of sure interest to all bridge fans. New York: Experimenter Publishing Company.



THIS book, "Bridge by Whitehead," is causing widespread interest throughout the entire country. The new picture method that is used to illustrate every play has reduced the intricacies of the game to a minimum. Every one can now learn to play this popular game with ease. "Bridge by Whitehead" is the most complete instruction course ever written. It is just the thing for beginners and for old timers too. You are never too good a player not to heed the advice of Wilbur C. Whitehead nor too poor a player for him to give it.

Write today—Get your copy of "Bridge by Whitehead." Don't wait! This famous bridge player has given, in this new book, the secrets of the game that have made him a success. 100 pages—replete with illustrations—large 9" x 12" size.

**50c**

**THE COPY**

AT ALL NEWSSTANDS OR WRITE DIRECT  
**EXPERIMENTER PUB. CO.**  
230 Fifth Ave. New York, N. Y.

**EXPERIMENTER PUBLISHING CO.**  
230 Fifth Ave., New York N. Y.

Gentlemen: Enclosed find 50c, for which kindly send me a copy of Wilbur C. Whitehead's valuable book, "Bridge."

Name.....  
Address.....  
City..... State.....

but "C" batteries are not required. If the set has "C"-battery binding posts, the batteries should be disconnected and the posts short-circuited.

### External Volume Control for Converted A.C. Sets

THE table-type volume-control resistor, illustrated on this page, has been placed on the market just in time to satisfy the requirements of set builders. Today thousands of old sets are being rewired for A.C. operation and, when these changes have been made in the wiring of the set the volume control mounted on the front panel of the receiver often ceases to function. This is because many receivers employ a rheostat in the filament circuit of the R.F. tubes as a volume control; and, in the case of A.C. tubes, filament rheostats are seldom satisfactory. It is, therefore, necessary for the set builder to provide a new volume control for the receiver and, since it is frequently inconvenient or impossible to mount this instrument on the panel of the receiver, it must often be connected externally.

This table-type volume control is a variable resistor with a universal (approximately zero to 5,000,000 ohms) range, and may be used in a great many different ways as a volume control. It may be connected in shunt with the aerial and ground wires of the receiver; in shunt with the loud-speaker wires; across the secondary terminals

of an audio transformer; in series with the "B" power supply, etc.; and in each case it will provide efficient control of volume. Another advantage gained by use of an external volume control is that the volume of the music may be controlled from a remote point by running wires from the set to the place where the volume is to be regulated. For example, the volume may be controlled from an easy chair, across the room from the receiver, without the necessity of moving one's position.

The illustration on this page clearly illustrates the mechanical construction of the volume control. It is provided with two sets of wires, one long and one short; this makes it possible to take advantage of sev-

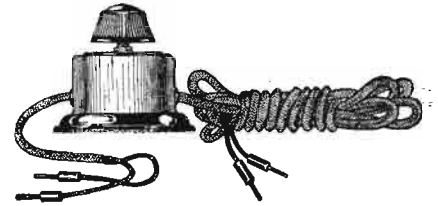

Table-type variable resistor, designed as volume control for receivers converted to A.C. operation.

eral unusual connections. The bottom of the unit is covered with felt so that it will not mar furniture. Electrically the unit may be described as a variable resistor of the carbon-compression type; four complete turns of the shaft are required to change the resistance of the unit from minimum to maximum.

(Names of manufacturers of the devices described furnished on request. See page 1319.)

## The Listener Speaks

(Continued from page 1324)

of which there are many. "Us lightning jerkers" donate our lead "two bites" too for the magazine, and I doubt if anyone would begrudge us a little space.

Of course it is a deplorable fact that the commercial operators cannot be hung to the yard arm, so that we will not cause any disturbance in the bedtime stories. Us commercial brass pounders are a very necessary fixture, and I think we do more good than enough to offset what little interference we might cause—so, why give us the razz? Respectfully, "JIMMY SPARKS," Newark, N. J.

the deal, disregarding the facts of the matter. WILLIAM F. CLARKE, 667 E. Fifth Street, South Boston, Mass.

(We fancy that a large number of dealers who do not fall under this condemnation will reply at length on the subject of consumer confidence.—EDITOR.)

### Enjoys Radio Plays

Editor, RADIO NEWS:

Being one of those women who are kept at home in the evening by children too small to leave, I am especially interested when some announcer says, "We will now listen to the play, So-and-So." While I enjoy the music, and once in a while a mere serious address, a radio play is a special treat. Mrs. R. M. GOSKO, Box 102, Durham, Conn.

### Buyers vs. Builders

Editor, RADIO NEWS:

I have read with interest the section of your magazine devoted to the set constructors; but I see that, when DX is the topic, the set is always a home-made one, and the DX is always a question of distance. Now, I have constructed as many sets as the next fellow; but I have now a factory-made set.

Why not have a few defenders of the factory sets write? (Writing is up to our readers. We rely solely on them to fill "The Listener Speaks" and "Radio Constructors")

### He Has His Doubts

Editor, RADIO NEWS:

I feel that I must commend Armstrong Perry for his excellent and interesting article in the January number—"How to Begin." He encourages the radio enthusiast: I have heard several radio men tell of the hardships, bad hours, hard grinds, etc., all more or less misleading and discouraging to a beginner, because they took the dark side and didn't say anything about the other. I suppose they intend to keep as many out of the field as possible, in order not to overcrowd it; but I say that there is always a position for the ambitious and capable person, no matter what branch of work he enters. Mr. Perry refers to radio dealers as a good source of information, but I have found many to be very inadequate; that is, they advise you in order to get the best of

pages.—EDITOR.) Then, too, it seems to me that distance is not the only consideration. When you receive a distance station, I think its power should be considered. My best in this way is a 50-watt station 900 miles from here. I would like to hear from readers on this question. **THOMAS P. KEELEY,**  
16 Lark St., South Boston, Mass.

### It Sheltered Him

Editor, RADIO NEWS:

Many radio fans say that the Federal Radio Commission is making the air worse instead of better; but if it were not for the commission, many of these DX hounds, such as myself, would be able to get only local stations.

I have been looking around with an old three-tube set and run-down batteries; but last Saturday night about 10 o'clock I got many distant stations, such as KRLD, WSUN, PWX and KFI. Six months ago this was absolutely impossible, and I had to wait until about 1 a. m. to get any distance at all.

The Federal Radio Commission has done us fans a great deal of good, and I will close by saying that I will be glad to receive letters from any fan who wants to dispute this question with me.

As to daylight reception, about two weeks ago on Sunday afternoon I got WJZ on the speaker and WBAP on the headphones, both on the three-tube set.

**SHIRLEY L. MOREHOUSE,**  
22-26 So. Main Street, Elkhart, Indiana.

### From Cuba to the Kaw

Editor, RADIO NEWS:

I note some letters and discussion as to daylight DX on the broadcast waveband. It may be interesting to know that, at our studio, I have a stock model Radiola 28, A.C. operated with a No. 104 loud speaker. With the set coupled to a 150-foot aerial, it brings in W.E.A.F. regularly every day at noon; B. A. Rolfe's orchestra program from the Palais d'Or, New York, is a standby. There is quite some background noise, due to spark transmission around 500 meters from ships all around Cuba. Our station 6KW has been heard as early as 4:00 p. m. in Kansas City, Missouri; and regularly at noon over a range of 500 miles.

**FRANK JONES,**  
Manager Station 6KW, Tunica, Cuba.

(This station, for its power—100 watts—is one of the best known in the world to DX fans. It may safely be presumed that, as it has a favorable location for transmission, it has one favorable also for reception. Editor.)

### Announcers, Attention!

Editor, RADIO NEWS:

For the general reader, RADIO NEWS tops them all. Both cover and contents are attractive. You give quantity and quality for twenty-five cents. As a listener-in for five years may I give briefly some of my conclusions?

There is a magical charm in having your thoughts expressed in type. The charm has lasted hundreds of years. So it is in radio: it is weirdly wonderful to hear the voices from the air. Just as in printing, beautiful

craftsmanship sometimes makes maudlin ideas seem wonderful; so in radio good mechanism enhances the music of commonplace artists. Then again, splendid artists sometimes seem crudely rude. Broadcasting as an art is in a stage of development.

We remember how General Dawes tore the microphone to pieces when he first came over the air, likewise we remember how often we have tuned out sopranos when they begin to "holler." Coloratura sopranos come over better because they have acquired control of the upper register; they cannot work unless they do. Ballyhoo gets nowhere in radio when the high-salaried singer following begins to scream at us.

Radio is an iconoclast. It strips away pretensions. If you are trying to be funny and have not got a funny voice stay away from radio.

When a beautiful structure is complete the scaffolding is torn away. The Greeks said, "The greatest art is to hide art." If an announcer is a good organist, why announce him as announcer and organist? If the janitor is a fine harmonica artist, why lug the janitor into his performance? It may not be strictly honest for a reader not to mention the book; nevertheless the magic of radio departs when the book is mentioned. We can read the book ourselves.

Speakers and announcers should use liquid labials in their speech. It would be a revelation to again hear the musically-sweet, liquidly-modulated voices of Edwin Booth or Lawrence Barrett in the "Lady of Lyons," "Rosedale," or "David Garrick."

Cut out the ugly consonants and hissing sounds. Is it necessary to say: "This iz Sztation WJZ, New York?" The call letters may well be repeated and the station announced: "Station WJZ, New York, WJZ." Havana has a good announcer, likewise WSAI, Cincinnati.

Women's voices sound alike in radio. When they talk they have a tragic tone. When they sing many of them seem to lose control of the high notes and scream or yell. (This does not apply to coloratura sopranos or contraltos.) Women talk very distinctly over the radio and should make good announcers. Radio artists should use the telephone for practice work.

Tearing passion to tatters is about the same as static. The less fuss you make near our mutual friend Mike, the better it comes.

Finally, the fellow that uses pee-uh-ust ought to be indicted for murder.

**JEREMIAH JOHNSON,**  
Brookland, D. C.

### What Broadcasters Want

Editor, RADIO NEWS:

I am enclosing an applause card that the Syracuse Post-Standard supplies for the asking; it has a Listeners' Club here. We have had them for two years. Why not have newspapers in other cities and towns do the same, as it advertises the town and paper? It is much easier to fill out the card than to write a long letter to each station.

**CITAS W. IRISH,**  
518 Montgomery St.,  
Syracuse, N. Y.

(The card enclosed is an excellent one, though it does not emphasize the principal point in which sponsors are concerned—interest in the special number on the pro-

## XL Products

Model  
"N"  
Variable-Denser





**Used in  
Every High Grade Circuit  
or Receiver Today!**

**X-L NEW BAKELITE INSULATED  
PUSH POSTS**

The perfect binding post at last! Convenient, simple; permanent connections. You don't have to remember to tighten them. Push down the X-L insert wire, remove pressure. Connection is tight and will STAY tight. No vibrations can loosen. Release instantly. Engraved in all standard markings. Price each, 15 cents.

**FREE** Big new up-to-date book of wiring diagrams of all leading circuits. Write today for copy.

## XL Radio Laboratories

Dept. A, 1224 Belmont Ave., Chicago, Ill.

**DEPENDABLE "B" BATTERY POWER**



100 Volt Edison Element.  
Non Destructive. Rechargeable "B" Battery with charger. Shipped dry with solution. \$12. 140 Volt with charger, \$17. 180 Volt Power Unit with Trickle Charger, \$24.00. Free sample cell. See how it operates.

**SEND NO MONEY—PAY EXPRESSMAN**  
Write for our Free Illustrated 24-page Booklet  
**SEE JAY BATTERY CO., 915 Brook Ave., New York**

Special Library of Information  
on  
**RADIO PATENTS**  
and  
**TRADE MARKS**

**JOHN B. BRADY**  
Patent Lawyer

Ouray Building Washington, D. C.  
Cable address: **RADIOPAT** Telephone: **Main 4806**

## FREE RADIO GUIDE

**BIG NEW 1928 CATALOG—4000 items**  
Shows the latest A-C circuits, the newest ideas in radio at startling low prices. Get the sets and parts you want here. Save money. The best in parts, kits, complete factory-built sets and supplies. Orders filled same day received. Write for free copy now.

Standard discounts to dealers, set builders, agents.  
**Barawik Co., 129 N. Jefferson St., Dept. 806B Chicago, U. S. A.**

Your Next "B"  
Power Supply  
Had Better "B" the  
**NATIONAL BETTER "B"**  
NATIONAL CO., INC. MALDEN, MASS.

# DEALERS

See page 1388



**DEALERS  
PERSONAL  
EDITION**

# Buy or BUILD with confidence and Insure Permanent Enjoyment of Your Radio Set!

## USE "THE DIRECTORY OF STANDARD RADIO SETS"

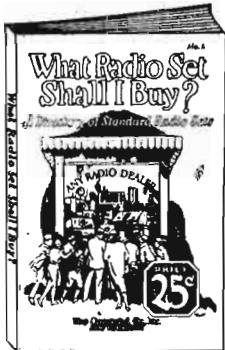

for  
buying

THERE is one easy—simple way to decide on what Radio Set to buy. If you are particular as to the style of the set, the power, the sensitivity, the price, or anything that has to do with a manufactured set you will find a complete answer in the "DIRECTORY OF STANDARD RADIO SETS."

Photographs of all standard manufacturers are shown together with an exhaustive printed description furnished by the manufacturers themselves.

This book is absolutely impartial. It is the only printed book in existence that gives you this information.

40 pages of descriptions and illustrations, size 6 x 9 inches with handsome colored cover. PRICE 25c.

## USE "HOW TO TUNE YOUR RADIO SET"



to  
enjoy all  
programs

RADIO Receivers know no rules of etiquette—they cannot be taught to act on best behavior when company and friends are judging them—but they can be made to act properly if the operator understands the few simple factors that effect tuning or the proper adjustment of the Receiver's controls.

Be one of those on the safe side. Don't be afraid to invite friends and show them that good tuning means good reception and enjoyable programs.

The 64-page, illustrated book on "How to Tune Your Radio Set" (Conrad—25c) is a carefully prepared, yet simplified, instruction book on tuning alone.

Receivers of different types, individual characteristics, are handled separately. All there is to know, all that must be known before one can really say to understand the tuning of a set—is given in this book.



only  
\$1.00

buys an entire set of these four books of vital importance to every one owning or contemplating the purchase of a radio set.

They can be bought separately if desired at

25c each

Fill out the coupon below and mail it with your remittance today.

All orders filled promptly.

## USE "THE RADIO TROUBLE FINDER"

to insure  
permanent  
satisfaction

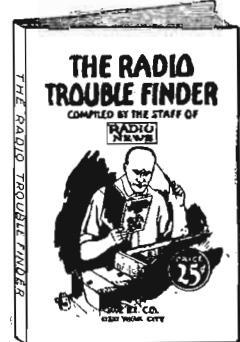

THE "RADIO TROUBLE FINDER" is a book prepared by a Radio Expert with many years of practical experience. It is a proven fact that 99 out of every 100 complaints from Radio set owners can be traced to simple and minor troubles that a child could repair with a simple book of instructions—and only once in a lifetime the average man need pay an expert to repair his set—if he has a copy of the "RADIO TROUBLE FINDER."

This simplified 64-page book charts all troubles and how to correct them. It is the simplest thing imaginable to use it. Even the more difficult jobs of changing internal mechanism of the set can be accomplished successfully.

The "RADIO TROUBLE FINDER" contains 64 pages, many of which are illustrated. It is size 6 x 9 inches, with a colored cover.

PRICE, 25c.

## USE "150 RADIO HOOKUPS"

for  
BUILDING



THIS 68-page book of the Conrad Company is the latest compilation of Hookups in Radio. The Hookups are those that have been tried, tested and perfected by time and by thousands of Radio Listeners. This priceless book contains: 18 Crystal Detector Circuits, 39 Regenerative, 21 Reflex, 23 Radio Frequency, 10 Super-Regenerative, 10 Amplifier and Oscillator, 5 Super-Heterodyne and other valuable Hookups.

All circuits are shown by simplified drawings and each is explained in detail. The book is 6x9 inches in size, illustrated, and is contained in a special attractive 2-color cover.

PRICE, 25c.

CONRAD CO., INC., 230 5th Ave., New York.

Gentlemen: I enclose \$..... for one copy of

- Directory of Standard Radio Sets.
- Radio Trouble Finder.
- How to Tune Your Radio Set
- \$50 Radio Hookups.

Name.....

Address.....

City, State.....

gram for which the advertiser pays. Another interesting individual form comes from George A. Porter of 141 Lincoln Street, Savannah, Georgia. Mr. Porter's blank is devoted to this important subject—and incidentally is illustrated with a little advertising of the advantages of his home city, of which he is evidently a loyal supporter. He observes: "A few cents a day for radio is well spent. I like to tell those I like that I heard their efforts; so this is what I use." A general disposition to do the same would solve the "applause" question for stations and sponsors.—EDITOR.)

**YMCA Health Broadcasts**

Editor, RADIO NEWS:

I read with interest the article on radio, "The Alarm Clock of the Nation", by Julia Shawell in the March issue of RADIO NEWS; but I was surprised to find that your writer had apparently made a very superficial survey of the morning exercise field. I have been making a series of studies in this field during the past few months and have discovered stations in every part of the country, at least a dozen of which are of major importance, giving this daily morning health broadcast.

Credit for the health broadcast idea should be given also to KYW, Chicago, who, jointly with P. A. Leonhart, Physical Director of the Chicago Y. M. C. A., started a regular broadcast several months before Bagley, who is now with the Metropolitan Life and who has been with the Newark, New Jersey, Y. M. C. A., began his first series. Bagley's material, as well as the Metropolitan Life Insurance, follow closely the lines of Leonhart's original exercises which are still being continued on WMAQ, Chicago. The feature is going on the air

over KMOX, St. Louis, on March 12, being sponsored by the St. Louis Y. M. C. A.

The Y. M. C. A., even more than the Metropolitan Life Insurance Company, is interested in health and the promotion of body building exercises. Your writer will discover, if she investigates a bit more thoroughly, that Y. M. C. A. physical directors have been reaching large audiences wherever stations have been cooperating. I pass this information on to you because I know that you want to make features of this kind as comprehensive as possible.

ARNO J. HAACK,  
Public Relations Secretary,  
The St. Louis Young Men's Christian Assn.

**DX-Getting In Asia**

Editor, RADIO NEWS:

I am a radio enthusiast, and the owner of a Crosley 5-50, with which I have heard remarkable DX programs. At present I can get one German station every night, and although I cannot get the call letters, from the wavelengths given in the RADIO LISTENERS' GUIDE, I believe it to be Breslau. Besides this, I am able to log 5AF, Calcutta, India. I mean to say that these two stations were tuned in with fairly good loud-speaker volume. I am sure readers interested in DX records will be glad to hear of this.

EDWARD C. TOCRO,  
P. O. Box 65, Japanese Consulate,  
Tientsin, China.

(While greater distances of reception have been reported, these records of Mr. Tocro have been made across the great mountainous land-mass of Asia. It is somewhat over 5,000 miles airline from Tientsin to Breslau; and about 2,750 to Calcutta, through a belt bad for static.—EDITOR.)

**Shoppers Beware of the Radio "Gyp"**

(Continued from page 1315)

it displays at strikingly low prices. They make no effort to get such merchandise in response to customers' requests. Their plan is obviously to entice people into the store for the purpose of 'switching' them to the brands which they desire to sell.

"The character of nationally-known products is defamed, and purchasers are frequently persuaded to accept substitutes. The scheme lends itself to many vicious practices.

"One complainant states that he asked for a certain trade-marked transformer. He was given a wrapped package, which he later found contained a brand other than that for which he asked. The store refused to exchange it or to refund his money. He was forced, in this manner, to accept the substitute."

**"WAITING IN VAIN"**

"Every possible strategy is used to keep the attention of the customer from the 'bargain' which enticed him into the store. If the prospective buyer shows determination, he is discouraged by being kept waiting for long periods of time. In one instance, a man reported that he waited an hour, and was then asked to return the next day. When insistent customers return at the appointed times, they are again put off. As a final resort, clerks have on occasion flatly refused to sell the goods.

"Westinghouse trickle chargers were dis-

played in the company's windows for \$5.95 (as shown in the picture). The clerk put the charger on the counter for the customer's inspection. Beside this he placed another brand selling at a higher price. He said the Westinghouse was not as good as the second charger and that the store now had fifteen of them in their stock room which had been returned because they had burned out. He then stepped to the telephone and returned stating that he had called the stock room of the store and learned that it would be necessary to send to the Westinghouse factory to get the particular charger offered in the window.

"The shopper waited for nearly an hour expecting to have the Westinghouse charger arrive from the factory. The clerk advised him to return the next day. At that time he was informed that the Westinghouse product would not be guaranteed. Other derogatory statements were made. The shopper insisted upon buying the desired charger and offered to accept the model displayed in the window. The clerk became brusque in manner and flatly refused to make a sale."

**"ALLEGED FALSE TESTS"**

"These selling practices are not confined to any particular article of radio equipment. When necessary, other elaborate tricks are used. The most deceptive of these for the inexperienced radio fan is the making of a

**Guaranteed**  
**Socket Power**  
**A Unit—\$13.75**



**90-Day Guarantee**

An absolutely unequaled value! We want you to test the World "A" Socket Power Unit and compare it with any other of two or three times the price. Try for ten days at our risk. Then if you are not convinced that it is unsurpassed as to quality and wonderful results, purchase price will be refunded in full. Operates on 50 or 60 cycles at 110 volts A. C. Highest quality Westinghouse electrical equipment. No hum or noise. Approved by Radio News Laboratories and other leading Authorities.

**Send Order Today** Just write your name and address on a slip of paper—plus a one dollar bill to it and mail today. We will ship same day order is received for \$12.75 C. O. D. 5% discount for cash with order. Remember you are the judge and are fully protected—so send order NOW.

**only \$1.00 Down Balance C.O.D.**

**WORLD BATTERY COMPANY**  
1241 S. Michigan Avenue  
Dept. 60 Chicago, Illinois

[ Station W. S. B. C., owned and operated by ]  
World Battery Company



**AMPERITE**  
Watch Dog of Your Tubes

**Insuring Tube Efficiency**

AMPERITE alone gives utmost life and performance from tubes. Because AMPERITE alone keeps the filament voltage, or temperature, constant, despite "A" battery variations. Particularly wiring and panel Battery Eliminators. Simplifies wiring and panel design. Eliminates hand rheostats and guessing. Proved for 6 years. Entirely different from fixed filament resistors. There is no alternative. Insist on AMPERITE. Price \$1.10 with mounting (in U. S. A.) At all dealers. Free—Write for "Amperite Book" of season's best circuits and latest construction data, to Dept. RN-6

RADLALL CO., 50 Franklin St., New York

**AMPERITE**  
REG. U. S. PAT. OFF.

The "SELF-ADJUSTING" Rheostat

**RAISE BELGIAN HARES**  
New Zealand Redo—Chinchillas—Flemish Giants  
MAKE BIG MONEY—Viv. Supply Stock and pay you following prices for all you raise:  
Belgian Hares \$2 each—New Zealand \$3 each  
Chinchillas \$4 each—Flemish Giants \$5 each  
\$2—page illustrated book, catalog and contract. Also copy of Fur Farming magazine, tells how to raise mink, fox, etc. for big profits, all for 10c.—Address  
OUTDOOR ENTERPRISE CO., Box 73, Holmes Park, Wisconsin

**FORMICA KIT PANELS**  
Drilled and decorated for leading kit sets are available through leading jobbers everywhere.

THE FORMICA INSULATION COMPANY  
4614 Spring Grove Avenue, Cincinnati, Ohio

# Dealers

## What is the Radio Trade saying?

---Read



EVERY worthwhile development of the Radio industry is fully treated in the pages of RADIO NEWS—DEALERS PERSONAL EDITION. New, tried, sales practices that have proven successful are given in each issue of this monthly TRADE paper. RADIO NEWS—DEALERS PERSONAL EDITION is edited by the whole Radio trade; each article that it contains is written by some successful dealer, jobber or manufacturer. This is a Trade Paper in every sense of the word. Are you making use of it? Remember every copy of the Dealers Personal Edition is mailed out under one cover with a copy of RADIO NEWS. This means that you get a 25c copy of RADIO NEWS—FREE.

Take advantage of this trade paper—your trade paper. Let it help you as it is helping thousands of others. Mail this coupon now. Assure your getting the next issue of this magazine. Remember you also receive a copy of RADIO NEWS—FREE. Take advantage of the special introductory subscription rate of \$1.50 for the combination.

### RADIO NEWS AND THE DEALERS PERSONAL EDITION

ATTACH YOUR LETTERHEAD  
THIS IS IMPORTANT

EXPERIMENTER PUBLISHING CO.  
230 FIFTH AVE., NEW YORK N. Y.

EXPERIMENTER PUBLISHING CO., INC.,  
230 Fifth Ave., New York, N. Y.

Gentlemen: Enclosed find \$1.50. I wish to take advantage of the special subscription offer. Kindly see that I get a copy of the RADIO NEWS DEALERS PERSONAL EDITION each month for one year beginning with the next issue.

Name.....

Address.....

City..... State.....

comparative 'test.' These 'tests' always favor the article which the clerk wishes to sell.

"A shopper attempted to buy the Eveready Battery shown in the window at a price of \$2.69. The same system of making deprecating statements was employed, and attempts were made to sell another product at a higher price. The man, however, wanted the Eveready Battery. The clerk, therefore, made a supposedly-accurate test of the two batteries. This so-called test strongly favored the article which he was trying to sell. The Eveready Battery was finally purchased and when properly tested, was found to be quite different than the Parker test had shown.

"The trick test is particularly effective in demonstrating loud speakers. By manipulating the cord, making poor connection, and by other means, speakers may be made to sound like the scratching of a dishpan with a nail. An inferior speaker is then demonstrated, with proper connections, and sounds better."

#### "BOUGHT, BUT NOT SOLD"

"Persistent customers may evade and overcome the many snares in the Parker Radio Company's selling plan. In such a case there are several final measures to which the store resorts. The mere fact that a man selects merchandise, pays his money for it, and even sees it wrapped, does not mean that he will get it.

"In one case, when a tireless customer had overcome numerous obstacles and high-pressure sales methods, the clerk accepted his money in payment for a Radiola 100A loud speaker which was displayed for \$23.00, as illustrated. This speaker was taken to another part of the counter and partially wrapped when the clerk insisted upon demonstrating another speaker. He strenuously endeavored to sell this article, but the man was firm in his preference. The Radiola was again taken away to be wrapped.

"Working somewhat in the manner of vaudeville teams, this became the cue for another clerk, who approached the customer and engaged him in conversation. When the buyer turned back to the counter again, he discovered that the Radiola speaker had disappeared. He protested, and demanded its delivery because his money had been accepted. The clerks laughed as they returned his money and closed the transaction with the statement: 'You can't have it.'"

#### "TRICKERY AND INSOLENCE"

"If their trickery fails to close a sale on their own terms, they, on occasion, do not hesitate to become abusive. One person insisted upon purchasing certain radio tubes, displayed in the store window at a very cheap price. The salesperson endeavored to sell him a higher-priced tube and said that the others were seconds. Despite the clerk's statement to this effect the customer wished to purchase the merchandise. The clerk is reported to have said, 'You are too smart; if it were not for your old age, I would throw you out of the store.'

"Radio tubes are one of the items most frequently used as bait. Bureau shoppers who have endeavored to purchase well-known tubes at advertised prices have usually been told that they were seconds. The price cards in the windows, however, do not contain such qualification. The prospective customer is lured into the store on the assumption that he will get a first-class article at the price advertised."

#### "RIDICULOUS 'TECHNICAL' JARGON"

"Glib statements are sometimes made about the radio equipment, to confuse and deceive customers. The jargon of these high-pressure salesmen is often ridiculous to anyone with a knowledge of radio.

"A letter received by the Better Business Bureau states that the writer is a builder of radio sets. He was attracted to the store by a window display offering Atwater Kent phonograph unit Model B-5, at \$3.49. It required fifteen minutes for the clerk to 'locate' the merchandise. When it was finally produced the customer believed the unit was defective because something rattled inside when it was moved. He directed the clerk's attention to this defect. The answer which he received was that the unit contained a recent improvement known as a 'floating diaphragm.' This statement typifies the ingenious explanations sometimes used by clerks of the Parker Radio Company in foisting damaged merchandise upon unsuspecting customers. Needless to say, the 'floating diaphragm' was not a product of the Atwater Kent Manufacturing Company, but rather, of the clerk's imagination.

"Two shoppers attempted to buy R.C.A. 201A tubes for 75 cents, as advertised. Noting that the shoppers were women, the clerk assumed them to be ignorant of radio terms, and asked the make of the set in which the tubes were to be used. Learning that the set was a Radiola 16, he stated that the 201A tube would not work. Another tube selling at twice the price was recommended, and the salesman conducted an alleged test which appeared to demonstrate his contention that the R.C.A. would not meet the requirements. The shoppers noted the interesting fact that the second tube was of the 201A type, and it was later found that the R.C.A. tube would not work only because it was defective."

#### "'SECONDS' AS 'FIRSTS'"

"Perfect merchandise is sometimes represented as defective or "seconds," to suit the convenience of the seller. Likewise, 'seconds' are designated as 'firsts' to consummate a sale.

"A clerk said that a Western Electric speaker displayed in the window of the store at 203 Market Street for \$24.95, was second-quality merchandise. He endeavored to sell a higher-priced speaker but was forced with great reluctance, to sell the Western Electric. He warned the customer that it would not be guaranteed and could not be returned. He would not even allow the shopper to hear the speaker before it was taken out of the store. It required over half an hour to make this purchase. When the speaker was submitted to the manufacturer for test and examination, its performance was pronounced satisfactory."

#### "STORE DERIDES COMPLAINTS"

"The complaints of customers and the findings of the Better Business Bureau have been brought to the attention of the management of the Parker Radio Company. In nearly every case the stories of the complainants were ridiculed and the company stoutly maintained that the items displayed in its windows could be purchased freely at the advertised prices. The facts, however, do not bear out these assertions.

"Until the Parker Radio Company radically changes its present policy, and abandons its vicious practices, it is unworthy of confidence."

# England Goes in for Television

(Continued from page 1328)

copies of English radio magazines, you will find quite unbiased opinions of leading physicists which point to only one conclusion—something radically different and novel is wanted if television is to be a sister science to radio."

### PROMOTION AND PUBLICITY

From the contents of this letter, it might seem as though someone had been trying to foist on the public something which operates --yes, indeed!--BUT HOW? Of course a store with such a high reputation as Selfridge's enjoys cannot afford to sponsor anything that smacks of crookedness; but it is true that the managers of the store are not scientists or engineers, but only enterprising merchants.

These business men might be shown a screen on which appeared a silhouette of a man's face, and be told that "here is Television." If they had never seen anything better, with what could they make a comparison? Therefore, the store's advertising carried only the impressions of laymen desirous of being first in a great and profitable field; not that of trained radio men who have seen the most successful demonstrations in television, and can judge of the comparative merits of the performance.

Such advertising, therefore, is bound to cause a reaction in readers' sentiments, and skepticism, to even an undesired extent. The backers of a promising invention who have but limited capital, and wish to retain

control by financing the device through popular sales of stock, face the problem of attracting investors through striking and skillfully-arranged publicity. In so doing, there is a great danger that exaggerated or over-optimistic propaganda, even though it is permitted but passively by the promoters, will cast doubt on their proposition in the minds of the well-informed, and for only a short time appeal to the credulity or inexperience of the public and the unwary experimenter.

### DON'T BE A SUCKER

Readers of RADIO NEWS are again assured that, whenever there is a really-worth-while development in television available to the constructor and to the public, this magazine will be first in giving them full details. Until the laboratory apparatus, which has made possible the remarkable demonstrations we have in previous issues described, is released for public sale, the amateur can make nothing in his workshop except interesting toys—such as that which might be built up out of the components offered by Messrs. Selfridge.

As related in the April issue of RADIO NEWS (on page 1163), we have talked with engineers of the General Electric Company and of the Bell Telephone Laboratories, and they put the time for the amateur to come into the field at five years hence. They are, of course, conservative gentlemen, and the time may be only three years from now, or less—but, anyhow, it is *not* now.



## Is Your Set a 60 Percenter?

TOO many sets are delivering only 60% of the tones broadcast by the studio. Most of the audio systems choke off or distort the very tones which give that fullness and roundness which makes the difference between ordinary and Natural Reproduction.

Link up your Tuner to Natural Reproduction with the companion units, The AmerTran Push-Pull Power Amplifier and the AmerTran ABC Hi-Power Box.

You must hear it to appreciate it. Even your imagination will not exaggerate the difference. Write for full information or ask us to arrange a demonstration at your dealer's store, no obligation of course.

AMERICAN TRANSFORMER CO.

141 Emmet St., Newark, N. J.

Transformer Manufacturers for 28 years



## European Broadcast Stations

(Continued from page 1309)

	Meters	Watts		Meters	Watts
Radio Carthage, Tunis (Fr. Africa)	1800	2000	*Langenberg, Germany (L.A)	469	60000
Kaschau, Hungary	1800	3000	*Oslo, Norway	462	5000
*Radio Paris, France (CFR)	1750	10000	*Barcelona, Spain	460	1500
Kharkov, Russia	1700	1500	*Stockholm, Sweden	454	1500
*Daventry, England (5XX)	1604	25000	*Rome (Roma), Italy (IRO)	450	3000
*Moscow, Russia ("Komintern")	1450	12000	*Moscow, Russia	450	2000
*Karlsborg, Sweden	1376	10000	Brimm, Czechoslovakia	441	3000
Moscow, Russia	1350	2500	Vilna, Poland	435	1500
*Motala, Sweden	1320	30000	*Frankfort, Germany	429	10000
*Konigswusterhausen-Zeesen (Berlin), Germany	1250	45000	*Kattowice, Poland	423	10000
*Constantinople, Turkey	1200	20000	*Berne, Switzerland	411	5000
*Kalundborg, Denmark	1154	5000	*Reval (Fallin) Estonia	408	2500
*Warsaw, Poland	1111	10000	Glasgow, Scotland (58C)	405	1500
Basel, Switzerland	1109	1500	*Salamanca, Spain	403	1500
*Hilversum, Holland	1060	5000	Most de Marsan, France	400	1500
*Leningrad, Russia	1010	10000	Cork, Ireland	400	1500
*Minsk, Russia	950	12000	Aix-la-Chapelle (Aachen) Germany	400	1500
*Tiflis, Georgia (Asfa)	870	4000	*Hamburg, Germany (HA)	395	9000
Nizhni-Novgorod, Russia	860	1500	*Toulouse, France	392	5000
Rostov-on-Don, Russia	820	4000	Manchester, England (2ZY)	385	1500
Petrosavodsk, Russia	765	2000	*Helsingfors, Finland	375	1200
*Geneva, Switzerland	760	15000	*Madrid, Spain (EAJ7)	375	1500
Petrosavodsk, Russia	675	2000	*Leipzig, Germany	366	9000
Lausanne, Switzerland	680	1500	*London, England (2LO)	361	2000
*Barcelona, Spain	650	1500	*Prague, Czechoslovakia	349	20000
			*Rabat, Morocco (Fr. Africa) (PTT)	346	15000
			*Barcelona, Spain	345	1500
			Posen, Poland	345	1500
			*Copenhagen, Denmark	337	4000
			*Naples (Napoli), Italy (INA)	333	1500
			*Reykjavik, Iceland	333	1000
			Konigsberg, Germany	330	4000
			Bournemouth, England	326	1500
			Breslau, Germany	325	10000
			*Dublin, Ireland (2RN)	319	1500
			Milan (Milano) Italy	316	4500
			Newcastle, England (5NO)	313	1500
			Algiers (Fr. Africa)	311	2000
			*Zagreb, Jugoslavia	309	1250
			Casablanca, Spain	306	2500
			Belfast, No. Ireland (2BF)	306	1500
			*Nuremberg, Germany	303	9000
			Paris ("Radio Vitis"), France	302	2900
			Marseilles, France	300	1500

### IN THE AMERICAN BAND

Krakau, Poland	566	1500
Augsburg, Germany	566	1500
*Budapest, Hungary	557	4500
*Riga, Latvia	526	2000
*Milan, Italy (Vigentina)	550	7000
*Munich, Germany	536	9000
*Vienna, Austria ("Rosenthal")	517	28000
*Brussels, Belgium	509	1500
Upsala, Sweden	500	1500
Porsgrund, Sweden	500	1500
Linköping, Sweden	500	1500
*Daventry, England (5GB)	492	30000
Kharkov, Russia	487	4000
*Berlin, Germany	481	9000
*Lyons, France (PTT)	476	5000

\* Position indicated on map by figures.

## The FUTURE

by

Professor A. M. Low

"THE FUTURE" is one of the most remarkable books of the age. Professor Low, the author, is a scientist of international reputation, also an experimenter and inventor in the many branches of science. This book written by him has aroused widespread interest. It deals with the world of the future, certainly an unusually absorbing subject. Written in the popular, non-technical fashion, "The Future" reveals the many advances and changes that are in store for humanity in a new life to come.

This book has received favorable comment in book reviews the world over. Do not neglect to read this treatise on the future by Professor A. M. Low. It is a literary treat for everyone.

Mail your order now! Don't wait, everybody is reading this remarkable book.

Price—\$2.00

Experimenter Publishing Co.  
230 Fifth Ave., New York, N. Y.

Gentlemen: Enclosed find check or money order (check wisely) for \$2.00. Kindly send me a copy of Prof. A. M. Low's new book "THE FUTURE."

Name.....  
Address.....  
City..... State.....

# OPPORTUNITY AD-LETS

Follow these advertisements every month. Reliable advertisers from all over the country offer their most attractive specials in these columns.

Classified advertising rate twenty-two cents a word for each insertion. Ten per cent discount for 6 issues, 20 per cent discount for 12 issues. Names and addresses must be included at the above rate. Cash should accompany all classified advertisements unless placed by an accredited advertising agency. No advertisements for less than 10 words accepted.

Objectionable or misleading advertisements not accepted. Advertisements for the August issue must reach us not later than June 1st.

**CIRCULATION LARGER THAN THAT OF ANY OTHER RADIO PUBLICATION**

EXPERIMENTER PUBLISHING CO., INC., 230 Fifth Avenue, New York, N. Y.

## Agents Wanted

**Big Money and fast sales.** Every owner buys gold initials for his auto. You charge \$1.50; make \$1.35. Ten orders daily easy. Write for particulars and free samples. American Monogram Co., Dept. 133, East Orange, N. J.

**Guaranteed Genuine Gold Leaf Letters** anyone can put on store windows. Large profits, enormous demand. Free samples. Metallic Letter Co., 422 N. Clark, Chicago.

**Sell subscriptions to magazines known the world over.** Steady monthly income with absolutely no investment required. Hundreds of selling arguments every month. Start now. Full information sent free, no obligation. Agency Division, Experimenter Publishing Co., 230 Fifth Avenue, New York.

**Agents—We start you in business** and help you succeed. No capital or experience needed. Spare or full time. You can earn \$50-\$100 weekly. Write Madison Products, 500 Broadway, New York.

**Agents Wanted to Advertise Our Goods** and distribute free samples to consumers; 90c an hour; write for full particulars. American Products Co., 1505 Monmouth, Cincinnati, Ohio.

## Authors

**Authors.** Protect your stories, plays, songs, etc. by U. S. Copyright. Get New Booklet Free! Coy Co., Brownley Bldg., Washington, D. C.

## Business Opportunities

**Inventions Commercialized.** Patented or Unpatented. Write Adam Fisher Mfg. Co., 278 Enright St., St. Louis, Mo.

**67 Ways to Increase Income.** 96-page book "Spare-time Money Handbook" contains 67 practical and complete plans to operate sparetime business. For everyone who wants more money. Price only 50c. Conrad Company, Inc., 230 Fifth Avenue, New York.

**Amateur Cartoonists:** Make money in spare time with new cartoon selling plan. Write Smith's Service, Waukegan, Wash.

**Free Book.** Start Little Mail Order business. Haswell, 5A-74 Cortlandt Street, N. Y.

**Make big profits with Chinchilla Rabbits.** Real Money-makers. Write for facts. Box 131, Conrad's Ranch, Denver, Colo.

## Chemistry

**Learn Chemistry at Home.** Dr. T. O'Connor Sloane, noted educator and scientific authority, will teach you. Our home study correspondence course fits you to take a position as chemist. See our full-page ad on page 1261 of this issue. Chemical Institute of New York, 16 E. 30th Street, New York City.

**\$4.00—Astounding Chemical Offer—\$4.00.** We will ship prepaid anywhere in United States our chemical outfit consisting of 100 expensive pure laboratory chemicals, cash or C.O.D., \$4.00. Swinmer Chemical Company, 1500 St. Marks Ave., Brooklyn, N. Y.

## Correspondence Courses

**Used correspondence school courses** sold on repurchase basis. Also rented and exchanged. Money-back guarantee. Catalog free. (Courses bought). Lee Mountain, Pisgah, Alabama.

## Electricity

**Electric Fun!** Seventy stunts, 110 volts, \$1. Coopero, Campbell, Calif.

## For Inventors

**Inventions Commercialized.** Patented or Unpatented. Write Adam Fisher Mfg. Co., 278 Enright, St. Louis, Mo.

**Radio Amateurs.** We can market New radio attachments quickly and profitably. Give full details. E. M. Clarke Co., 1533 Chestnut St., Phila., Pa.

## Help Wanted

**National Publisher,** needs agents, boys and shops to help sell great national magazines. No investment required. Big profits, sparetime work very successful. Write Agency Division, Experimenter Pub. Co., 230 Fifth Avenue, New York.

## Help Wanted, Instructions

**Do You Drive a Car?** U. S. Government Chauffeur-Carrier job pays \$141-\$175 month. "How to Qualify" mailed free. Write, Ozmest Instruction Bureau, 251, St. Louis, Mo.

## Instruction

**Learn Chemistry at Home.** Dr. T. O'Connor Sloane, noted educator and scientific authority, will teach you. Our home study correspondence course fits you to take a position as chemist. See our full-page ad on page 1378 of this issue. Chemical Institute of New York, 16 E. 30th Street, New York City.

## Male Help Wanted

**Men—Big pay working romantic South America.** Fare, expenses paid. South American Service Bureau, 14,600 Alma, Detroit, Mich.

## Metals for Radio Manufacturers

**We Make copper, brass, nickel silver, bronze, phosphor bronze, and other special alloys** in all tempers, either plain or hot film coated, in strips or in coils. Quality guaranteed. The Baltimore Brass Company, 1201 Wisconsin Street, Baltimore, Md.

## Miscellaneous

**Inventions Commercialized.** Patented or Unpatented. Write Adam Fisher Mfg. Co., 278 Enright, St. Louis, Mo.

**Save Money at Home.** You can build many home necessities yourself, such as furniture, kitchen utensils, decorative material, etc., thus saving many dollars. All instructional information on hundreds of things given in 116-page book "How to Make It." Price 50c. Experimenter Publishing Co., Inc., 230 Fifth Avenue, New York.

**Forms to Cast Lead Soldiers, Indians, Marines, Transfers, Animals, 151 kinds.** Send 10c for illustrated Catalogue. H. C. Schlerke, 1034 72nd St., Brooklyn, N. Y.

**Big Bunch Mail.** Year 15c. Catalogues, magazines. Kentucky Agency, Covington, Kentucky.

## Old Money Wanted

**\$2 to \$500 each** paid for hundreds of Old or Old Cains. Keep all old money. It may be very valuable. Send 10c for New Illustrated Coin Value Book, 48c. Guaranteed prices. Get posted. We pay Cash. Clarke Coin Company, 14 Street, LeRoy, N. Y.

## Patent Attorneys

**Mason, Fenwick & Lawrence,** Washington, D. C., New York and Chicago. Established 1861. Inventions protected, trade-marks registered. Information given—write promptly.

**Patents—Send for form "Evidence of Conception"** to be signed and witnessed. Form, fee schedule, information free. Laweater and Albright, Registered Patent Attorneys in United States and Canada, 269 Ouray Bldg., Washington, D. C.

**Patents—Send drawing or model of your invention** for examination and instructions. Advice and booklet free. Highest references. Best results. Promptness assured. Watson E. Cotnam, Patent Lawyer, 724 9th Street, N.W., Washington, D. C.

**Patent Sense—Valuable book free.** See Lacey's ad page 1273. Lacey & Lacey, 631 F. St., Washington, D. C. Established 1874.

**Patents procured** at reasonable rates with time to pay. Sales negotiated. Staff of registered attorneys and engineers. A complete service for inventors. Write for particulars. Inventors Service Bureau, Box 1648, Washington, D. C.

## Patents

**Inventions Commercialized.** Patented or unpatented. Write Adam Fisher Mfg. Co., 278 Enright, St. Louis, Mo.

## Printing, Engraving and Multigraphing

**\$2.95 Buys 1000 Finest Bond 6 1/2 Envelopes.** OBERMAN COMPANY, Box 1268, Chicago.

**Multigraphing,** two dollars thousand. Miscellaneous Printing. Mayer Key Corporation, Monmouth, Illinois.

## Radio

**Press and public concede it to be the best ever produced.** "Radio Theory and Operating," by Mary Texanna Loomis, member Institute of Radio Engineers. Lecturer on radio. Loomis Radio College. Thorough text and reference book. 886 pages, 740 illustrations. Price \$3.50, postage paid. Used by Radio Schools, Technical Colleges, Universities, Dept. of Commerce, Govt. Schools and Engineers. At bookdealers or sent on receipt check or money order. Loomis Publishing Company, Dept. B, 495-9th St., Washington, D. C.

**Be the Licensed Radio Doctor** of your community. \$7-\$10 spare time evenings. Our cooperative plan procures all the work you want. Secure franchised territory now. Write for booklet. Co-Operative Radio Doctors, Dept. N, 131 Essex St., Salem, Mass.

**Short Wave Receiver \$25.00.** Harold Campbell, 69 Vine St., Bridgeport, Conn.

**Write about our efficient power devices.** KIMLEY ELECTRIC CO., 441 E. Ferry, Buffalo, N. Y.

**Serpa B Eliminators \$2.75** deliver 135 volts. Require slight repairs. 5-tube sets in massive walnut cabinets \$25.00. Free 30 day trial. 2 microfarad condenser blocks \$0.65. 4 microfarad \$1.30. 20 Henry chokes \$1.00. Step up transformers \$1.75. Crystal sets \$2.95. Charles Hoodwin Company, Dept. 10, 4240 Lincoln Ave., Chicago Ill. Dealers in Bankrupt Stocks.

## Salesmen Wanted

**Make \$75.00 Saturdays, Sundays.** Wonderful opportunity for entire summer. No experience required. Write for free catalog. Benson Camerascop Co., 25-N Delaney St., New York.

**A paying position open** to representative of character. Take orders shoes, hosiery, direct to wearer. Good income. Permanent. Write now for free book "Getting Ahead." Tanners Shoe Mfg. Co., 876 So. C. St., Boston, Mass.

**A Good Line:** Suitable for all or part-time. Can be sold in big cities or small towns; any place. Every business house needs envelopes in different sizes, weights and qualities. Many buy in large quantities. Our line includes stationery, and is very complete. The samples are flat, carry easily, weigh little, look good; prices reasonable. Commission liberal and paid promptly. You would like our offer. American Envelope Company, Mexico, Missouri.

## Scenery to Rent

**World's Most Beautiful settings** for operas, plays, musicals. Amelia Grain, Philadelphia.

## Song Writers

**Song Writers—Substantial Advance Royalties** are paid on publishable work. Anyone having original ideas for songs may submit poems for examination and free advice. Walker Neweater, 1674 Broadway, New York.

## Telegraphy

**Telegraphy—Both Morse and Wireless** taught thoroughly. High salaries. Wonderful opportunities. Expenses low. chance to earn part. School established fifty years. Catalog free. Currier's Institute, Cour St., Valparaiso, Ind.

## Wanted to Buy

**Full Value Paid for Old Gold, Jewelry, Watches, Diamonds, crowns, bridges, dental gold, silver, platinum, gold or silver ore; magnetite points, old false teeth.** Packages returned if our offer is not satisfactory. United States Smelting Works (The Old Reliable), 29 So. State St., Dept. 16, Chicago, Ill.



	Meters	Watts
Hanover, Germany	297	1850
Cartagena, Spain (EAJ16)	297	1500
Uddevalla, Sweden	294	1500
Lyons, France	291	1500
Edinburgh, Scotland (2EH)	289	1500
Köln (Cologne) Germany	283	4000
Angers, France	279	1500
Seville, Spain	278	1500
Salzburg, Germany	279	1500
Trollhattan, Sweden	279	1500
Norrköping, Sweden	275	1500
Bordeaux ("Lafayette"), France	273	2000
Genoa, Italy	273	1500
Danzig (Independent)	273	1500
Bremen, Germany	273	1500
Lemberg, Poland	270	1500
Rennes, France	270	1500
Lisbon, Portugal	268	1500
Linz, Germany	254	1500
Kiel, Germany	254	1500
Kalmar, Sweden	254	1500
Säffle, Sweden	252	1500
Kassel, Germany	252	1500
Gleiwitz, Germany	250	1500
Eskestuna, Sweden	250	1500
Toulouse, France	246	2000
Münster, Germany	242	3000
Bordeaux, France	238	1500
Stettin, Germany	236	1500
Orrebro, Sweden	236	1500
Bucharest, Rumania	236	2000
Boras, Sweden	231	2000
Umea, Sweden	229	1500
Belgrade, Yugoslavia	226	2000
Leningrad, Russia	224	10000
Karlstad, Sweden	221	1500
Sofia, Bulgaria	216	1000
Gävle, Sweden	204	1500
Kristianhamn, Sweden	203	1500
Jönköping, Sweden	201	1500
Blarritz, France	200	1500

\* Position indicated on map by figures.

(NOTE: The powers listed here are not exactly comparative, owing to different methods of rating the European stations. Those of Central Europe are usually given according to the input; so that a 1500-watt station, in most instances, probably corresponds to an American 500-watt transmitter, and so on.

The wavelengths of many of the smaller stations are subject to frequent change, and the latest published lists show differences. The wavelength congestion in Europe has led in places to what is practically a radio war, of stations jamming each other, on the shorter waves. Those of the larger, high-power stations, most of which are on waves above 600 meters, are less subject to this trouble.)

## I Want to Know

(Continued from page 1356)

The apparatus used in the set diagramed in Fig. Q, 2282 is as follows:

- Three T.R.F. coils, L1, L2, L3;
- Three .0035-mf. variable condensers, C1, C2, C3;
- Two .002-mf. fixed condensers, C4, C5;
- One .00025-mf. fixed condenser, C6;
- One .001-mf. fixed condenser, C7;
- Three automatic filament ballasts, R;
- One grid leak, R1;
- Two 10,000-ohm resistors, R2;
- Three tube sockets;
- Seven binding posts;
- Panel, baseboard, wire, etc.

The tuned-radio-frequency coils can be made by winding 82 turns of No. 22 D.C.C. wire on 2 1/2-inch tubing for the secondary; and 14 turns for the primary, with about 1/4-inch spacing between the coils. Any type of audio-frequency amplifier can be used with this set and should be connected in the normal manner to the output of the detector.

The small coils, L4 and L5, and the fixed condensers should be mounted directly on the terminals of the variable resistors. These resistors can be mounted inside the set, since it is not necessary to readjust them when the set has been balanced correctly. When laying out the apparatus on the baseboard, the coils L1, L2 and L3 should be placed as far apart as possible, and at right angles. If desired, the tuning condensers can be ganged together to simplify the tuning; but it will be advisable to place small compensating condensers across each section of the gang condenser, to correct any differences in inductance or capacity of the coils or condensers.

### OBTAINING SELECTIVITY

(2282) Mr. C. B. Douglas, Chicago, Illinois, asks:

(Q.) "What are the important points in obtaining selectivity from a receiver?"

(A.) There are a number of general points which may be watched in building and improving receivers for increasing the selectivity. The following series of rules may be followed in almost every case, except for a few special receivers, such as super-regenerative sets, etc.

- (1) Employ loose coupling between the primary and secondary of the tuning coils.
- (2) Keep wide spacing between the parts in the receiver and between the wires.
- (3) All wiring should be as short as possible, and grid and plate wires should not be run parallel.
- (4) Keep all plate and grid wires far apart, and separated from other wiring in the receiver.
- (5) Watch soldered joints and keep all terminals clean and tight.
- (6) Keep the contacts on tube bases and sockets clean.
- (7) Avoid material and construction which will cause losses in coils, such as metal in the field, too-fine wire, etc.
- (8) Keep the condenser plates clean.
- (9) Do not use, for controlling oscillation and regeneration, methods which introduce losses into the tuned circuits.
- (10) Solder all antenna connections and use good insulation.
- (11) Keep the aerial clear of all objects.
- (12) Make a good ground connection to a water pipe or metal buried in the ground.
- (13) Use tuned circuits with large inductance and small capacity.
- (14) Use a short aerial, well insulated.
- (15) Use regeneration in the detector stage when properly controlled and when at least one radio-frequency stage precedes the detector (this is advisable, since the set will cause interference in the neighborhood if the regenerative detector is coupled directly to the antenna).

There are three main classifications of causes of lack of selectivity in a receiver. The first is excessive resistance in the tuned circuits and in the antenna. The second class includes mistakes in coupling between any of the circuits in the set; loose coupling should be employed wherever possible in tuned-radio-frequency circuits. The third class includes faulty relationship between the inductance and the capacity of the tuned circuits. As a rule, the inductance should be very great in comparison with the capacity of the tuning condensers. Increasing the ratio of inductance to capacity will often improve both the selectivity and the sensitivity at the same time.

### STATEMENT OF THE OWNERSHIP, MANAGEMENT, CIRCULATION, ETC., REQUIRED BY THE ACT OF CONGRESS OF AUGUST 24, 1912.

of RADIO NEWS, published monthly at New York, N. Y., for April 1, 1928.

State of New York,  
County of New York, ss.

Before me, a Notary Public, in and for the State and County aforesaid, personally appeared Hugo Gernsback, who, having been duly sworn according to law, deposes and says that he is the Editor of Radio News, and that the following is, to the best of his knowledge and belief, a true statement of the ownership, management, etc., of the aforesaid publication for the date shown in the above caption, required by the Act of August 24, 1912, embodied in section 411, Postal Laws and Regulations, to wit:

1. That the names and addresses of the publisher, editor, managing editor, and business manager are:  
 Publisher, The Experimenter Publishing Co., Inc., 220 Fifth Avenue, New York, N. Y.; Editor, Hugo Gernsback, 220 Fifth Avenue, New York, N. Y.; Managing Editor, Robert Hertzberg, 220 Fifth Avenue, New York, N. Y.; Business Manager, Chas. E. Rosenfelt, 220 Fifth Avenue, New York, N. Y.

2. That the owners are:  
 The Experimenter Publishing Co., Inc., Hugo Gernsback, Sidney Gernsback, R. W. DeMott, H. W. Soren, Dr. T. O'Connor, Jerome J. S. Madsen—all of 220 Fifth Avenue, New York, N. Y.; Mrs. Catherine Major, 225 West 125th Street, New York, N. Y.; M. M. Johnson, 720 Cass Street, Chicago, Ill.; L. F. McClure, 720 Cass Street, Chicago, Ill.

3. That the known bondholders, mortgagees, and other security holders owning or holding 1 per cent or more of total amount of bonds, mortgages, or other securities are: None.

4. That the two paragraphs next above, giving the names of the owners, stockholders, and security holders, if any, contain not only the list of stockholders and security holders as they appear upon the books of the company but also, in cases where the stockholder or security holder appears upon the books of the company as trustee or in any other fiduciary relation, the name of the person or corporation for whom such trustee is acting, is given; also that the said two paragraphs contain statements embracing affiant's full knowledge and belief as to the circumstances and conditions under which stockholders and security holders who do not appear upon the books of the company as trustees, hold stock and securities in a capacity other than that of a bona fide owner; and this affiant has no reason to believe that any other person, association, or corporation has any interest direct or indirect in the said stock, bonds, or other securities than as so stated by him.

H. GERNSBACK.

Sworn to and subscribed before me this 21st day of March, 1928.

JOSEPH B. KRATZ.

(My commission expires March 20, 1929.)

[Seal]

## BENJAMIN

### Cle-Ra-Tone Sockets

**Red Top**

**Green Top**

For Standard UX Type Tubes. For quick and easy finding of correct position of tube and prongs.

A new Five Prong Socket for A. C. Detector Tubes. Especially designed for heavy current-carrying capacity for these new tubes.



Cle-Ra-Tone Sockets are spring supported to absorb the shocks that distort tonal qualities. The tube "floats" on four finely tempered springs, which absorb shocks and jars from slamming doors, passing traffic and other disturbances caused by outside vibrations. One-piece terminal to tube connection. Positive contacts. Knurled nuts for binding post connections or handy lugs for soldering.

At All Radio Jobbers and Dealers

**Benjamin Electric Mfg. Co.**  
 120-128 So. Sangamon St., Chicago  
 247 W. 17th St. New York      448 Bryant St. San Francisco

## YAXLEY

APPROVED RADIO PRODUCTS

### RADIO CONVENIENCE OUTLETS

Wire your home for radio. These outlets fit any standard switch box. Full instructions with each outlet.

No. 135—For Loud Speaker . . . . . \$1.00  
 No. 137—For Battery Connections. 2.50  
 No. 136—For Aerial and Ground . . . 1.00

With Bakelite Plates  
 Now furnished with a rich satin-brown Bakelite plate, with beautiful markings to harmonize, at 25 cents extra. See illustration.

At Your Dealers

**YAXLEY MFG. CO.**  
 Dept. N-9 So. Clinton St.  
 Chicago, Ill.



E.C.A. "A" Eliminator, 60 cycle, 110-V., output 2 1/2 Amp. 6-V. SILENT \$16.50.  
 B Eliminator, 150-V., 4 taps, with 213B bulb, \$10.00.  
 2 amp. Eutonia charger, \$7.00. 2 amp. DRI rectifier, series base, \$2.25. Catalog.

**ELECTRO-CHEMICAL COMPANY OF AMERICA**  
 Indianapolis, Ind.

## Agents Wanted

to solicit subscriptions

Be the first in your city to earn a dollar and more per hour in your spare time.

**We Want**

men and women everywhere who will devote a few hours a day to easy pleasant work.

**Write today**

for full information.

AGENCY DEPT.  
**EXPERIMENTER PUB. CO.**  
 230 Fifth Ave., New York City

# WHOLESALE PRICES

for Dealers, Community Set Builders, General Repairmen and Agents!

Be sure to get this great 144-page book with net prices to the radio trade.

Radio Specialty Company is radio's oldest radio parts mail order house in the country, and the new confidential prices on standard radio merchandise are the lowest of any radio house.

We are ready now to appoint additional agents in all parts of the country. If you are contemplating making big money in radio merchandise, be sure to get in touch with us at once.



New  
**1928**  
ENLARGED  
EDITION  
No. 18

New 75  
HOOKUPS  
500  
ILLUSTRATIONS

THIS  
144 PAGE  
RADIO  
CATALOGUE  
FREE

## BUY from Radio's Oldest Mail Order House!

We are the oldest established, exclusive radio mail order house in the country. All orders are positively shipped within twenty-four hours: quick, prompt, courteous service. We carry a larger variety of radio parts, radio instruments, accessories and radio findings than any other radio house in the country.

### "RASCO" has it

ANYTHING  
IN RADIO

You will find in Catalog No. 18 the largest assortment of radio merchandise in this country. Radio Specialty carries more radio parts and radio material than any other house in the country. You will find in this catalog positively the largest variety of radio merchandise.

If you are in need of certain small radio parts that other radio and mail order houses do not bother to carry get the Rasco Catalog and you will find the small parts there, anything from a screw to copper ribbon, telephone diaphragms, as well as thousands of other small radio findings. Just to mention a few:

Lugs, nuts, jacks, plugs, all kinds of knobs, cords, panels, screws, sliders, washers, selenium, tinfoil, switches, crystals, cap nuts, Litz wire, cord tips, brass rods, resistances, binding posts, switch parts, carbon balls, switch points; lock washers, carbon grains, ground clamps, metal pointers, insulated tubing, low melting metal, antenna connectors, as well as thousands of other articles. We carry the Largest Variety of Small Radio Parts in the World, BUT We also carry All Standard Radio Merchandise.



# Radio Specialty Co.



98W PARK PLACE, NEW YORK

# Here's the new improved SUBANTENNA

**Easily Installed in a Few Minutes—  
Guaranteed to Bring in Loud, Clear DX  
Right Through Summer Static**



**STATIC  
NO LONGER  
CUTS UP  
RECEPTION**

**How  
This  
Amazing  
New Under-  
ground  
Antenna Works**

It is a known fact that radio waves travel through the ground just as they do thru the air. Ground waves, however are much clearer than air waves, because air waves are more or less cut-up with static and other disturbances, while the ground is practically free of all such interference. The new improved Subantenna—a real, scientific device completely enclosed in a small, compact sealed and moisture-proof can, is buried in the ground in a vertical position. It intercepts the clear, strong, static-free ground waves and sends them up to the receiver via a shielded cable. Comparison, station for station, of reception taken from the ground with a Subantenna and reception obtained in any other way, instantly establishes the worth of this great new device.

**Tested and Proved  
Tremendously Successful on Every  
Type of Set**

Subantenna was put to countless tests before being offered to you. It was tried out on as many types of receivers as it was possible to obtain. In every test the new improved Subantenna exceeded all previous standards for antenna performance. It is sure to work on your set. It is certain to so greatly improve your reception and to so greatly increase your radio enjoyment that you would not part with this new, better antenna for twice its price if you could not get another.

**Users Agree It  
is the Greatest New  
Thing in Radio**

"I have a switch on my cabinet by which I can throw from an aerial to the Subantenna. For example I tune in WEAF on the Subantenna and find I have to turn down my volume control to almost a full quarter away from 'OFF.' Then, reversing to the aerial I can hear barely a sound, and this is only the same night I installed the Subantenna. If it improves with settling, it should be more than remarkable."

Neville Seymour, Newark, N. J.



Here it is—the new, improved and perfected SUBANTENNA—even better than its amazingly efficient predecessor which brought forth volumes of enthusiastic praise from thousands of critical fans. Now it's ready—the new SUBANTENNA—ready to prove its DX ability—ready to challenge any type of loop or up-in-the-air aerial—ready to challenge those who have tried to produce an underground antenna of comparable efficiency, but who can't because the features of the new SUBANTENNA which make it so superior to anything else are patented. In short, here's the ideal antenna. Loud, clear DX regardless of the season—regardless of

weather—regardless of how much static there is in the air.

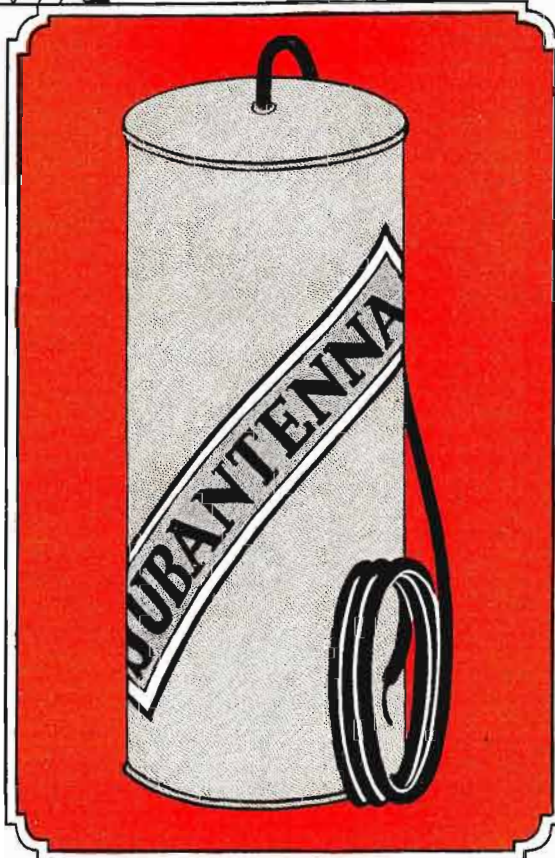

**Beats Everything Else**

"I am writing to tell you that last night I gave my Sub a good test and must say it has anything but that I have ever seen and under any conditions. The stations always come in at the exact same spot, and the quality and tone are far better than obtained with the noisy overhead aerial. You had better send me some order blanks. You did send me some before but I misplaced them."

A. W. Turner, Baltimore, Md.

**FREE  
TRIAL!**



We want you to install the new, improved SUBANTENNA. Installation takes only 5 minutes. We want you to try it on your own set—entirely at our risk! Test it, try it in every way. Compare the reception it brings you, to the reception you can get with any other kind of antenna. If it isn't clearer, louder, sweeter and better in every way, this test is free.

**MAIL COUPON  
TODAY**

Clip, fill in and mail now. No obligation whatever. We'll send you full details of the new improved SUBANTENNA and particulars of our FREE TRIAL OFFER and the truly amazing tests we want you to make entirely at our risk. Mail the coupon right now ... at once.

Cloverleaf  
Mfg. Co.  
2714 C Canal St.  
Chicago, Illinois  
Send me full details of  
the new, improved Sub-  
antenna and particulars of  
Free Trial Guarantee Offer.

Name.....

Street.....

Town.....

State.....

**Cloverleaf Mfg. Co., 2714 C Canal St., Chicago**

**SEND NOW FOR GUARANTEE OFFER**

# **ABOX Electric "A" Power Makes any Set Electric**

## **No Changes in Tubes or Wiring**



### **6-Volt Abox Eliminator**

This model will operate any set using eight or less standard 6-volt tubes. Not necessary to change set wiring. Over 100,000 of this type in use.

**\$ 32<sup>50</sup>**



### **4-Volt Abox Eliminator**

A new model for sets using 4-volt tubes. Fits Radiola battery compartment. Size 8 $\frac{3}{4}$  in. long, 4 in. wide, 6 $\frac{1}{4}$  in. high. Output—.6 amperes, 4 volts D.C.

**\$ 27<sup>50</sup>**

All Prices Slightly higher  
on West Coast

The Abox method of A.C. conversion is extremely simple and economical. Abox is merely connected in place of the battery or socket power unit, and your set is 'electric.'

No changes are required in the wiring of the set. No harnesses, adapters, special transformers or new set of expensive tubes are necessary to give you the advantages of an A.C. receiver. None of the good features of your set are sacrificed—instead it always operates at maximum efficiency.

Remember that it is not practical to presume that a set designed for standard tubes will work as effectively with other types. Abox does not change the basic circuit of the set, nor make obsolete the volume controls, as do the ordinary type of A.C. conversions.

Abox will make any standard set an A.C. receiver without imperilling its efficiency, and at the lowest possible cost.

It is a rectifier-filter combination made in a six-volt model for sets using eight or less standard  $\frac{1}{4}$  ampere tubes, or sixteen of the proposed new  $\frac{1}{8}$  ampere tubes, and in a four-volt model for Radiolas and all sets using 199 type tubes.

Abox can be purchased at most dealers. If your dealer cannot supply you, write direct to us.

**THE ABOX COMPANY**  
215 North Michigan Avenue, Chicago, Illinois

Gentlemen: Please send me complete information on how I can make my set electric with Abox. Also include free construction article on the Abox ABC Eliminator and Power Amplifier.

Name.....

Address.....

Check here if you are a dealer

Use coupon for free circular

## The ABOX Company

215 North Michigan Avenue

Chicago, Illinois