

TELEVISION

RADIO'S GREATEST MAGAZINE

RADIOVISION

RADIO NEWS

REG. U.S. PAT. OFF.

OCTOBER
25 Cents

Over 200
Illustrations



Edited by HUGO GERNSBACH

"SEEING" MUSIC WITH A
TELEVISION RECEIVER
SEE PAGE 314

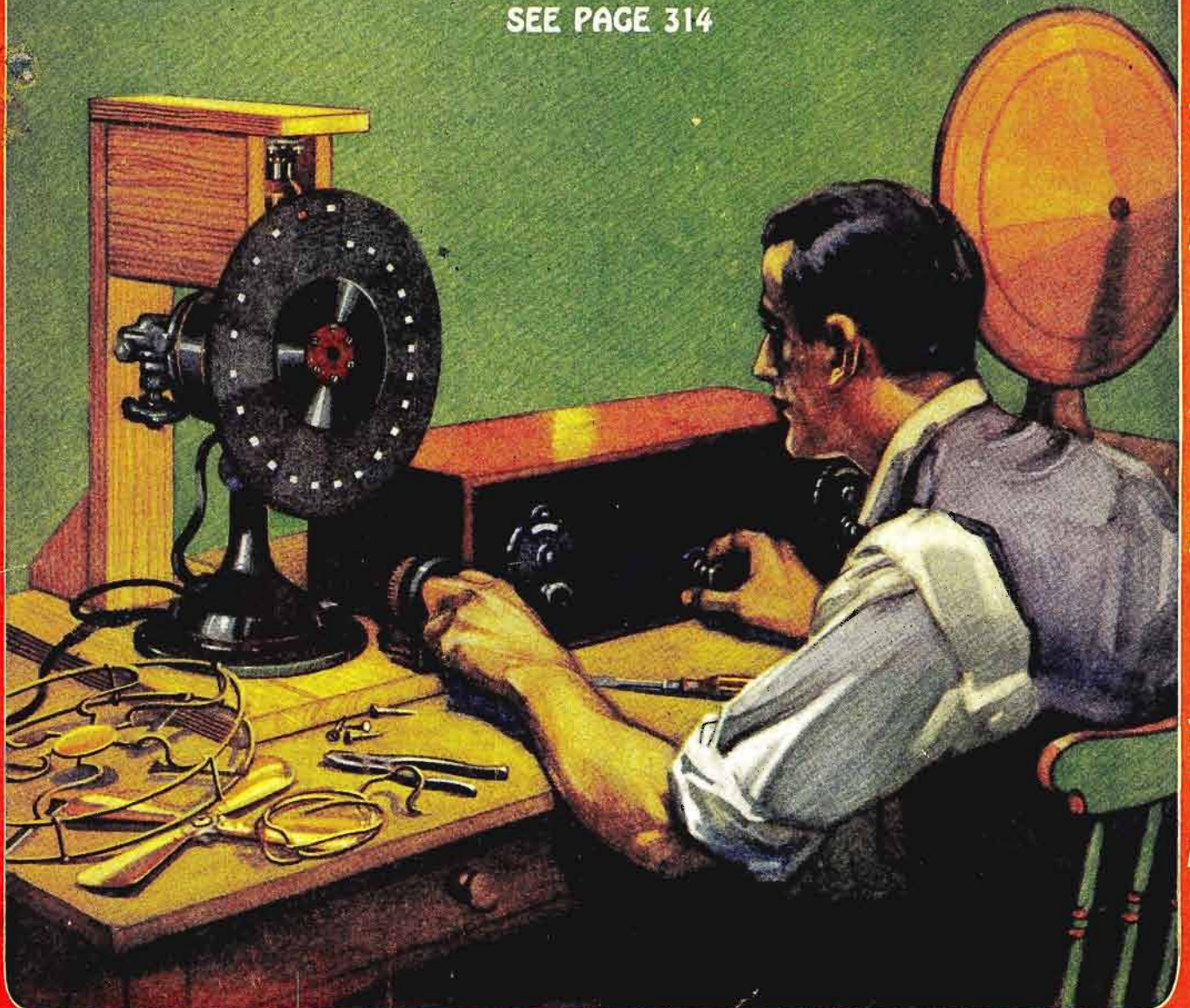

RADIOVISION

TELEVISION

RADIOVISION

TELEVISION

RADIOVISION

TELEVISION

RADIOVISION

TELEVISION

RADIOVISION

TELEVISION

TELEVISION

EXPERIMENTER PUBLISHING COMPANY, 230 FIFTH AVENUE, NEW YORK

RADIOVISION

New!

WONDERFUL RADIO!
Super-Eight—100% Electric
8 TUBES—SINGLE DIAL
Coast-to-Coast

Shipped Direct from our Factory on

30 Days Free Trial

[Battery or Electric]

Now comes Metro's latest achievement—the world's greatest electric radio set—a powerful long distance eight tube receiver—clearness of tone that is astounding—ultra-selective—a set that expert radio engineers have pronounced as the ultimate for all around perfection. And to prove our claims, we will send this marvelous set to you direct from our factory on 30 days' free trial. Test it to your heart's content. Compare its quality, beauty and price with any other radio on the market, and decide to keep it only after you are satisfied that the new 1929 Metrodyne super-eight is the peer of them all.

Metrodyne

SUPER-EIGHT ELECTRIC

Save One-Half—Low Price a Big Feature!

You will be amazed at the low price of these wonderful sets, in the console or table cabinet. Our low cost of distribution direct from our factory enables us to save you about half their regular value. Never before in radio history have you been offered such sets at such low prices. And we are so sure of their quality, beauty and performance pleasing you that we do not hesitate to let you try one for 30 days before deciding to keep or return it.

SUPER QUALITY THROUGHOUT!

Eight powerful tubes. Highest quality low loss parts. Illuminated single dial. Positive switch control—simply turn a knob and it's on. Select your stations with accuracy at any desired volume. Beauty of tone that cannot be surpassed. Console and table cabinets are hand-somely grained genuine walnut, hand rubbed, in two-tone effect—artistically carved trimmings. All metal parts finished in two-tone gold. Seeing is believing. You will be the judge.



Georgous console with newest type, built-in sonorous loud speaker that reproduces the entire range of vocal and instrumental music. Amazingly clear and distinct. Low, direct-from-factory price on 30 DAYS' FREE TRIAL!

AGENTS and DEALERS

The 1929 Super-Eight line offers great money making opportunities. Nothing like them for high quality—nothing near them in price. Let us prove this by shipping you a

Demonstration set on 30 days' free trial

Test it—compare it—demonstrate it to prospective radio buyers. Get our liberal discounts—exclusive territory—newspaper and billboard advertising offer that will help you sell Metrodyne radios quickly.



**Send Coupon Today for Our
30 Days' Free Trial Offer** →

**METRODYNE
RADIO SETS
Are Equipped For
BATTERY or
ELECTRIC
OPERATION**

We are one of the pioneers of radio. The success of Metrodyne sets is due to our liberal 30 days' free trial offer, which gives you the opportunity of trying before buying. Thousands of Metrodynes have been bought on our liberal free trial basis. We will send you hundreds of letters from owners who acclaim the Metrodyne as the greatest radio set in the world. A postal, letter or the coupon brings complete information, testimonials, wholesale prices and our liberal 30 days' free trial offer—WRITE TODAY!

METRO ELECTRIC COMPANY
2161-71 N. California Ave., Dept. 11
Chicago, Illinois

Gentlemen:
Send me full particulars about Metrodyne Super-Eight sets and your 30 days' free trial offer

Name _____

Address _____

If you are interested in AGENT'S proposition, place an "X" in the square

METRO ELECTRIC COMPANY

2161-71 N. California Ave. • Dept. 11 • Chicago, Illinois

EARNED \$500 SPARE TIME WITH RADIO

Coplay, Pa., June 4—(RA)—During the few months that Frank J. Deutsch has been a member of the Radio Association of America, he has made over \$500 out of Radio in his spare time.

"Four super-hetrodyne sets of my own construction brought me a profit of \$60.00 each, and the other profit was from sales of supplies purchased through the Wholesale Department of the Association," he said. "The Association certainly has a great plan for ambitious men."

In a neighboring state, Werner Eichler, Rochester, N. Y., another member of the Association, has been making \$50 a week during his spare time.

They are only two of the hundreds of Radio Association members who are making money out of Radio in their spare time.

BECOMES RADIO ENGINEER IN ONE YEAR

Toronto, Canada, May 20—(RA)—One of the newly admitted associate members of the Institute of Radio Engineers is Claude DeGrave, a member of the engineering staff of the DeForest Company of this city. "I knew nothing about Radio and started from the ground up," Mr. DeGrave stated, "when I enrolled a year ago in the Radio Association. Its easy lessons and superb training made it possible for me to become a Radio Expert in less than a year's time. My income is now about 225% more than at the time I joined the Association."

The Institute of Radio Engineers is a very exclusive organization, and its membership requirements are very rigid, so that Mr. DeGrave has reason to be proud of his election.

Clerk Doubles Income In Six Months Through Radio

Chicago, Ill., May 9—Even though his membership in the Radio Association has resulted in W. E. Thon securing the management of a Radio Department in a large Chicago store, his ambition was not satisfied. Six months later, he started his own store.

"The Radio Association has an excellent plan for the man who wants to get out of the rut and succeed," says this man who quickly rose from clerkdom to the proprietorship of a profitable radio store. "I attribute my success entirely to the Radio Association of America. Six months after I had enrolled, I had doubled my income through its help."

5 Easy Ways to make \$3.00 an hour in Your Spare Time in RADIO

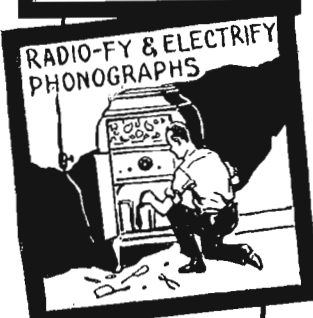

EACH of these plans, developed by the Radio Association of America, is a big money-maker. Set owners everywhere want to get rid of static, to have their sets operate from the electric light socket, the tone improved, and the volume increased, and transformed into single-dial controls. Phonograph owners want their machines electrified and radiofied. If you learn to render these services, you can easily make \$3.00 an hour for your spare time, to say nothing of the money you can make installing, servicing, repairing, and building radio sets, and selling supplies.

Over \$600,000,000 is being spent yearly for sets, supplies, service. You can get your share of this business and, at the same time, fit yourself for the big-pay opportunities in Radio by joining the Association.

Join the Radio Association of America

A membership in the Association offers you the easiest way into Radio. It will enable you to earn \$3.00 an hour upwards in your spare time—train you to install, repair, and build all kinds of sets—start you in business without capital or finance an invention—train you for the \$3,000 to \$10,000 big-pay radio positions—help secure a better position at bigger pay for you. *A membership need not cost you a cent!*

The Association will give you a comprehensive practical, and theoretical training and the benefit of our Employment Service. You earn while you learn. Our cooperative plan will make it possible for you to establish a radio store. You have the privilege of buying radio supplies at wholesale from the very first.

ACT NOW—If you wish No-Cost Membership Plan

To a limited number of ambitious men, we will give Special Memberships that may not—need not—cost you a cent. To secure one, write today. We will send you details and also our book, "Your Opportunity in the Radio Industry." It will open your eyes to the money-making possibilities of Radio.

COUPON

RADIO ASSOCIATION OF AMERICA
Dept. RN-10, 4513 Ravenswood Ave.,
Chicago, Ill.

Gentlemen:

Please send me by return mail full details of your Special Membership Plan, and also copy of your book, "Your Opportunity in the Radio Industry."

Name.....

Address.....

City..... State.....

RADIO NEWS

Volume 10

OCTOBER, 1928

Number 4

HUGO GERNSBACK, Editor-in-Chief

ROBERT HERTZBERG, Managing Editor

C. P. MASON, Associate Editor

FRED H. CANFIELD, Technical Editor

BERYL B. BRYANT, Laboratory Director

C. WALTER PALMER, Assistant Technical Editor

Contents of This Issue

What Is Coming in Television By Hugo Gernsback	299	Television in Natural Colors Demonstrated By Ronald F. Tiltman	320
The Radio Laboratory Takes Wings By S. R. Winters	300	How to Build from the Schematic—Part II By Fred H. Canfield	321
"Wired Wireless"—What It Is and Why By J. E. Smith	302	The Radio Beginner—"The Milk-Shaker Special" Receiver—By the Staff of RADIO NEWS Laboratories	324
The Photoelectric Cell—Radio's "Eye" By Dr. Lewis R. Koller	305	The "Combine" Receiver—a \$100 Prize Winner By W. H. Scheppele	328
The Listener Speaks By Himself	308	A Completely-Shielded Short-Wave Receiver By Herndon Green	334
Broadcastatics	309	The Search for the Perfect Amplifier By Sydney P. O'Rourke	338
What's New in Radio	310	Radio Wrinkles	340
Interesting New European Screen-Grid Tubes By Major R. Raven-Hart	313	Radiotics	342
Television—"Seeing" Music with a Television Receiver	314	On the Short Waves	343
Radio-Picture Equipment for Police By Dr. F. Noack	316	List of Broadcast Station Calls	344
The Fultograph Radio Picture-Broadcast System	317	The Radio Constructor's Own Pages	346
The Radio Bean Sorter—A Novelty By Herbert W. Augustadt	318	RADIO NEWS Laboratories	348
RADIO NEWS Free Blueprints Available for the Asking	319	I Want to Know By C. W. Palmer	350
		Adjusting and Operating the Screen-Grid Strobodync By R. E. Lacault	380
		Terms of Prize Awards	383

RADIO NEWS is published on the 10th of each preceding month. There are 12 numbers per year. Subscription price is \$2.50 a year in U. S. and possessions. Canada and foreign countries, \$3.00 per year. U. S. Coin as well as U. S. Stamps accepted (no foreign coins or stamps). Single copies, 25 cents each. Checks and money orders should be drawn to order of EXPERIMENTER PUBLISHING CO., INC.

All communications and contributions to this journal should be addressed to Editor, RADIO NEWS, 230 Fifth Ave., New York, N. Y. Unaccepted contributions cannot be returned unless full postage has been included. All accepted contributions are paid for on publication. A special rate is paid for novel experiments; good photographs accompanying them are highly desirable. Publishers are not responsible for loss of manuscripts, although every precaution is taken with such manuscripts, upon receipt thereof.

RADIO NEWS, Monthly. Entered as second-class matter, July 12, 1924, at the Post Office at New York, N. Y., under the Act of March 3, 1879. Additional entry at Dunellen, N. J. and San Francisco, Calif. Title registered U. S. Patent Office, Copyright, 1928, by The Experimenter Publishing Co., Inc., 230 Fifth Ave., New York. The contents of this magazine are copyrighted and must not be reproduced in the United States without giving full credit to the publication. Translation into foreign languages must not be made unless permission is

obtained from the publishers. Copyrighted in Germany. Reproduction of articles in Germany is reserved for Radio, Berlin 42.

RADIO NEWS is for sale at all newsstands in the United States and Canada, and at Brentano's, Ave. de l'Opera, Paris, France. European agents: S. J. Wilso & Co., 40 Place Verte, Antwerp, Belgium.

HOW TO SUBSCRIBE FOR RADIO NEWS. Send your name, address and remittance to Experimenter Publishing Co., 230 Fifth Ave., New York. Mention the name of the magazine you are ordering. We also publish SCIENCE AND INVENTION, RADIO LISTENERS' GUIDE, AMAZING STORIES and TRIBUTES. Write clearly.

RATES AND TERMS. The subscription rate for RADIO NEWS is \$2.50 per year. (12 numbers). When remitting do so by check, money order, or registered letter if cash is enclosed. Avoid sending cash through the mail if possible. Subscriptions for less than one year are not accepted. Subscription may be made in combination with SCIENCE & INVENTION, RADIO LISTENERS' GUIDE, AMAZING STORIES and TRIBUTES.

POSTAGE. We prepay postage in all parts of the United States, Mexico and island possessions. For foreign or Canadian subscriptions we require 50 cents in addition to the subscription price for additional postage charge.

CHANGE OF ADDRESS. Notify us as far in advance as possible. It requires several weeks to make an address change on our records. Always write clearly.

The contents of RADIO NEWS are indexed in the Industrial Arts Index, copies of which can be found in every library.

Published by **Experimenter Publishing Company, Inc.**

H. GERNSBACK, President

S. GERNSBACK, Vice-President and Treasurer

C. E. ROSENFELT, Secretary

Member: Audit Bureau of Circulations

Radio Magazine Publishers Association

Advertising Representatives: RHODES & LEISENRING

New York Offices: 624 Graybar Building

Chicago Offices: 307 North Michigan Ave.

Editorial and General Offices

230 Fifth Avenue, New York City

ONLY
\$99 for this **PACKARD**
SUPER 8—\$250 A. C.
ELECTRIC RADIO SET !

Direct From Our Factory

Today's greatest radio! A truly sensational offer! The Eight-tube PACKARD A. C. Electric Radio — a regular \$250 set — shipped to any home in the U. S. at direct from factory price of only \$99. And to prove our claims we will ship this set to your home on

\$5000.00
CASH BOND
to Back Our
GUARANTEE



The PACKARD Engineers

have invented this most unusual, powerful SUPER-Eight Tube Radio. Astonishing volume and tone quality. Remarkable selectivity and long-distance reception. Leading radio engineers unanimously agree that there is no better radio made — regardless of price.

Let us prove this by shipping a set to your home on 30 days' trial. Examine the set from A to Z. Let the most exacting critics pass on its merits. And if, after the 30 day trial period, you are convinced that the Packard Eight-tube Electric is fully the equal of any console radio set selling up to \$250—then, and only then, need you decide to keep it at our factory price of only \$99—otherwise, return it.

This marvelous set combines every new scientific development in receiving sets—possessing beauty, refinement, durability. Gets everything on the air from coast to coast—from Mexico into Canada, loudly, clearly, and distinctly. Only one dial to tune in all stations.

You Save the Jobbers', Dealers' and Salesmen's Profits

The PACKARD Radio is shipped direct from our factory. All the in-between profits are deducted from the price of the set and instead of paying \$250 you pay only \$99. Quantity production, economy in selling, and only a small profit for the manufacturer makes this astounding offer possible.

MAIL COUPON NOW FOR 30 days' free trial offer

Don't miss this opportunity. Mail coupon at once for complete information about the PACKARD A. C.—8 TUBE ELECTRIC RADIO and our liberal 30 days' free trial offer. No obligation on your part. Our \$5,000.00 cash bond backs up our guarantee.

PACKARD RADIO CO.
2323 Milwaukee Ave. Dept. 320 Chicago, Ill.



WORLD'S GREATEST RADIO
Genuine Walnut Console Cabinet

Eight powerful A. C. tubes and one genuine full-wave rectifying tube—nine tubes in all. Supreme quality throughout. Simple to operate. Connect the plug to electric socket and turn switch. Only one dial to tune. One hundred per cent electric. Handsome walnut cabinet—two-tone genuine DUCO finish. Metal trimming finished in old gold. Marvellous built-in, powerful speaker. Size of cabinet is 54 inches high, 27 inches wide.

Packard Radios are also made for BATTERY OPERATION PRICED AS LOW AS \$53

Packard Radio Company
2323 Milwaukee Ave., Dept. 320, Chicago, Ill.

I am interested in Packard Radios and your \$5,000.00 Bonded 30 days' free trial offer and guarantee. Send full details.

Name.....
 Address.....
 City..... State.....

INDEX TO ADVERTISERS

A	Page	F	Page	M	Page	S	Page
Acme Wire Co., The	375	Fanspeaker Radio Co.	381	M & H Sporting Goods Co.	396	School of Engineering of Milwaukee	396
Aerovox Wireless Corp.	389	Fergus Co., The	372	Massachusetts Radio & Telegraph School	383	Scott Transformer Co., Back Cover	
Aero Products, Inc.	378	Freshman Co., Inc., Chas. ...	381	Master Engineering Co.	368	See Jay Battery Co.	370
Allied Radio Corp., 356-358-372-374-393- 400-385-386-358				Metro Electric Co.		Setbuilders Supply Co.	358-391
Aluminum Company of America	359	G		Inside Front Cover		Shanklin Mfg. Co.	393
American Radio & Merc. Co.	388	General Radio Co.	391	MidWest Radio Corp'n	355	Shieldplate Tube Corp.	397
American Sales Co.	378-382	Gernsback, S.	380			Silver-Marshall, Inc.	294
Amrad Corporation, The.	383	Gray & Danielson Mfg. Co.	386	N		Smith, B. Hawley	395
Arcturus Radio Co.	399			National Company, Inc.	388	Southern Toy Co.	385
				National Electrical School.	388	Starrett Mfg. Co.	391
B				National Radio Institute 293-373			
Barawik Co., The, 356-358		H		National School of Visual Education	386	T	
360-368-370-374-378-381-383-385		Hammarlund Mfg. Co.	381	New England Mills Co.	378	Teleplex Co.	356
386-388-391-392-395-396-398-399		High Frequency Labs.	387			Televocal Corp.	356
Belden Mfg. Co.	368			P		Thordarson Elec. Mfg. Co.	353
Benjamin Electric Mfg. Co.	356			Pacard Radio Co.	291	Townsend Labs.	389
				Pathfinder Publishing Co.	391	Transformer Corporation of America	385
C				Penn Co., Geo. R.	395	Tyrman Electric Corp.	399
Carborundum Co., The.	370			Pilot Electric Co., Inc., 296-297-298			
Carter Radio Co.	368	I		Potter Mfg. Co.	360	U	
Ceco Mfg. Co.	354	Illinois Transformer Co.	356	Press Guild, Inc.	362	Underground Aerial System, Inside Back Cover	
Central Radio Labs.	362	Independent Elec. Works.	396				
Chemical Institute of New York, Inc.	394	Interstate Electric Co.	374	R		V	
Chicago Radio Apparatus Co.	389			Radiall Co.	395	Van Asche Radio Co.	392
Cloverleaf Mfg. Co.	396	J		Radio Association of America	289		
Consumers Radio Co.	391	J. M. P. Mfg. Co., Inc.	372	Radio Directory Section of Radio News	364-365	W	
Craftsman Radio Products	372	Jewell Electrical Instru- ment Co.	357	Radio Doctors, Inc.	387	Walker Co., The Geo. W. ...	378
Cunningham, Inc., E. T.	360			Radio Equipment Co.	372	Western Radio Mfg. Co.,	295-374
				Radio Institute of America	367	Wirt Co.	388
D		K		Radio Manufacturers Show Ass'n	397		
Daven Corp., The.	392	Karas Electric Co.	362	Radio Products Labora- tories	369	XY	
Denver Optic Co.	395	Knapp Electric Co.	379	Radio Specialty Co.	366	X-L Radio Labs	362
Directory Section of Radio News	364-365	Kodel Radio Corp.	367	Raytheon Mfg. Co.	358	Yaxley Mfg. Co.	389
Dresner Radio Mfg. Corp.	386			Rowan Co., Walter	395		
E		L					
Fby Mfg. Co., Inc., H. H. ...	392	Lacault, Inc., R. E.	377				
Electrad, Inc.	370-393	Lacey and Lacey	386				
Electric Specialty Co.	391	Lafayette Hotel	358				
Electro-Chemical Co. of America	383	Leutz, Inc., C. R.	363				
Elkon, Inc.	358-371	Lynch, Inc., Arthur H.	372				
Excello Products Corp.	399						
		Mc					
		McAlpin Hotel	391				

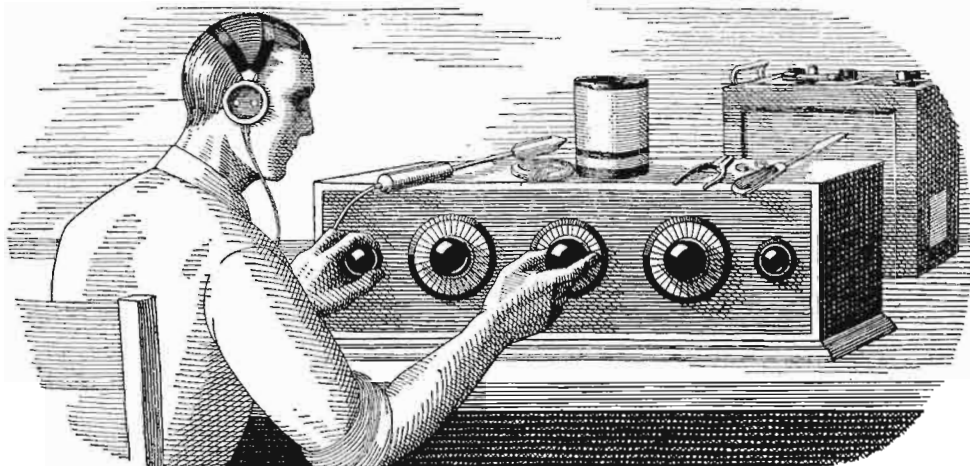

If all the Radio sets I've "fooled" with in my time were piled on top of each other, they'd reach about halfway to Mars. The trouble with me was that I thought I knew so much about Radio that I really didn't know the first thing. I thought Radio was a plaything—that was all I could see in it for me.

I Thought Radio Was a Plaything

But Now My Eyes Are Opened, And I'm Making Over \$100 a Week!

\$50 a week! Man alive, just one year ago a salary that big would have been the height of my ambition.

Twelve months ago I was scripping along on starvation wages, just barely making both ends meet. It was the same old story—a little job, a salary just as small as the job—while I myself had been dragging along in the rut so long I couldn't see over the sides.

If you'd told me a year ago that in twelve months' time I would be making \$100 and more every week in the Radio business—whew! I know I'd have thought you were crazy. But that's the sort of money I'm pulling down right now—and in the future I expect even more. Why only today—

But I'm getting ahead of my story. I was hard up a year ago because I was kidding myself, that's all—not because I had to be. I could have been holding then the same sort of job I'm holding now, if I'd only been wise to myself. If you've fooled around with Radio, but never thought of it as a serious business, maybe you're in just the same boat I was. If so, you'll want to read how my eyes were opened for me.

When broadcasting first became the rage, several years ago, I first began my dabbling with the new art of Radio. I was "nuts" about the subject, like many thousands of other fellows all over the country. And no wonder! There's a fascination—something that grabs hold of a fellow—about twirling a little knob and suddenly listening to a voice speaking a thousand miles away! Twirling it a little more and listening to the mysterious dots and dashes of steamers far at sea. Even today I get a thrill from this strange force. In those days, many times I stayed up almost the whole night trying for DX. Many times I missed supper because I couldn't be dragged away from the latest circuit I was trying out.

I never seemed to get very far with it, though. I used to read the Radio magazines and occasionally a Radio book, but I never understood the subject very clearly, and lots of things I didn't see through at all.

So, up to a year ago, I was just a dabbler—I thought Radio was a plaything. I never realized what an enormous, fast-growing industry Radio had come to be—employing thousands and thousands of trained men. I

usually stayed home in the evenings after work, because I didn't make enough money to go out very much. And generally during the evening I'd tinker a little with Radio—a set of my own or some friend's. I even made a little spare change this way, which helped a lot, but I didn't know enough to go very far with such work.

And as for the idea that a splendid Radio job might be mine, if I made a little effort to prepare for it—such an idea never entered my mind. When a friend suggested it to me one year ago, I laughed at him.

"You're kidding me," I said.
"I'm not," he replied. "Take a look at this ad."

He pointed to a page ad in a magazine, an advertisement I'd seen many times but just passed up without thinking, never dreaming it applied to me. This time I read the ad carefully. It told of many big opportunities for trained men to succeed in the great new Radio field. With the advertisement was a coupon offering a big free book full of information. I sent the coupon in, and in a few days received a handsome 64-page book, printed in two colors, telling all about the opportunities in the Radio field, and how a man can prepare quickly and easily at home to take advantage of these opportunities. Well, it was a revelation to me. I read the book carefully, and when I finished it I made my decision.

What's happened in the twelve months since that day, as I've already told you, seems almost like a dream to me now. For ten of those twelve months, I've had a Radio business of my own. At first, of course, I started it as a little proposition on the side, under the guidance of the National Radio Institute, the outfit that gave me my Radio training. It wasn't long before I was getting so much to do in the Radio line that I quit my measly little clerical job, and devoted my full time to my Radio business.

Since that time I've gone right on up, always under the watchful guidance of my friends at the National Radio Institute. They would have given me just as much help, too, if I had wanted to follow some other line of Radio besides building my own retail business—such as broadcasting, manufacturing, experimenting, sea operating, or any one of the score of lines they prepare you for. And to think that until that

day I sent for their eye-opening book, I'd been wailing "I never had a chance!"

Now I'm making, as I told you before, over \$100 a week. And I know the future holds even more, for Radio is one of the most progressive, fastest-growing businesses in the world today. And it's work that I like—work a man can get interested in.

Here's a real tip. You may not be as bad off as I was. But think it over—are you satisfied? Are you making enough money, at work that you like? Would you sign a contract to stay where you are now for the next ten years—making the same money? If not, you'd better be doing something about it instead of drifting.

This new Radio game is a live-wire field of golden rewards. The work, in any of the 20 different lines of Radio, is fascinating, absorbing, well paid. The National Radio Institute—oldest and largest Radio home-study school in the world—will train you inexpensively in your own home to know Radio from A to Z and to increase your earnings in the Radio field.

Take another tip—No matter what your plans are, no matter how much or how little you know about Radio—clip the coupon below and look their free book over. It is filled with interesting facts, figures, and photos, and the information it will give you is worth a few minutes of anybody's time. You will place yourself under no obligation—the book is free, and is gladly sent to anyone who wants to know about Radio. Just address J. E. Smith, President National Radio Institute, Dept 22S, Washington, D. C.

**J. E. SMITH, President,
National Radio Institute,
Dept. 22S, Washington, D. C.**

Dear Mr. Smith:
Please send me your 64-page free book, printed in two colors, giving all information about the opportunities in Radio and how I can learn quickly and easily at home to take advantage of them. I understand this request places me under no obligation, and that no salesman will call on me.

Name.....

Address.....

Town.....State.....

Occupation.....



FOREMOST in PERFORMANCE

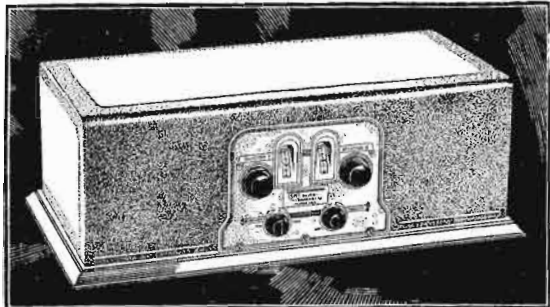

ON this page we present, in conjunction with one of our cooperating distributors, a summary of the most interesting information about kits and parts available to the setbuilder for the 1929 season under the most popular of all kit trade-marks.

Known always as a guarantee of reliability and sure results, the "S-M" mark carries this year an especial message of reduced cost, and of exceptional eye-value.



Power Supplies and Power Amplifiers

FOREMOST among all power devices are the famous S-M Reservoir Power Units and Unipac Power Amplifiers. High undistorted output, and uniform reliable operation are insured by the S-M standards of design and workmanship. All of the models here mentioned use standard tubes (not included in the kit price) and are supplied either in kit form, at prices given, or completely wired at slightly higher prices. Complete information is given in the big new S-M catalog.

For sets requiring 180 volts B, type 670B Reservoir Power Unit (\$40.50) will deliver up to 60 m.a. of current, with 22, 90, and 135 volts also available, besides 22-90 variable. The 670ABC (\$43.00) is similar but supplies also 1 1/2, 2 1/4 and 5 volt A.C. filament current. Type 675ABC (\$54.00) gives 450 maximum voltage instead of 180, and has an adapter which allows a 210 or 250 type super-power tube to be used in the last stage of any receiver at all.

Type 676 (\$49.00) is a Dynamic Speaker Amplifier; it amplifies output of any receiver through a 250 type tube, as well as supplying power to the speaker field. Adding an S-M 676 to any set having a dynamic speaker requiring 90 to 120 volts D.C. will improve marvelously both tone and volume.

S-M Unipac Power Amplifiers provide power amplification with super-power tubes (210 or 250 type), either single or in push-pull circuit, and all (except the 685) furnish B power also (45, 90, 135 volts) to the receiver. Where A.C. filament power is desired, an S-M 247 or 325 transformer is readily built into the amplifier. The 681-210 (push-pull, \$87.00) is the most powerful single-stage amplifier made. The 681-250 at \$81.50 uses only one power tube instead of two. Type 682-210 (2-stage push-pull, \$102.00) uses a 226 tube in a stage preceding its push-pull super-power stage. Type 682-250 at \$96.50 is similar, but with one super-power tube only in the last stage. Type 685 (\$125.00) is the popular Public Address Unipac, using three stages for the amplification of microphone, radio, or record pick-ups to cover crowds up to 10,000 people. The 685 is the only such light-socket unit available, and presents a marvelous opportunity.

All S-M Unipacs give to the output not only tremendous volume when wanted, but at all times that fidelity in tone quality which is not to be had without super-power tubes. The new S-M catalog gives full information about power amplification, and is sent free on receipt of the coupon below.

Are you receiving "The Radiobuilder" regularly? Published every month, this little magazine provides you with the earliest information on forthcoming S-M developments and with operating hints and kinks that will help you to get the most out of radio. To S-M Authorized Service Stations, "The Radiobuilder" is mailed each month, free of charge, together with all new Data Sheets and Service Bulletins as they come from press. To all others a nominal charge is made; see coupon.

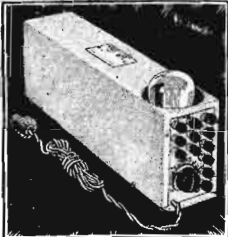

Audio Transformers Radically New and Different

ALWAYS foremost in audio amplification, Silver-Marshall brought a surprise to the thousands who have regarded the older S-M audios as the summit of perfection, by introducing an entirely new principle in transformer manufacture—hailed at the 1928 R.M.A. Trade Show as the greatest advance in quality of reproduction brought forth in years.

These new S-M audios—the first transformers to give freedom from the hysteretic distortion found in all other

types—are available in two sizes. The 225 first-stage and 226 second-stage (\$9.00 each) show a curve absolutely without parallel. (See E, below). The 235 first-stage and 256 second-stage (smaller transformers at \$6.00 each; see curve D) are still far in advance of any audios hitherto available at eight and ten dollars—such as seen at B, C, and D (actual curves of three well-known high-priced transformers).

Remember it—you can have this finer performance in every set you build!

If you don't wish to build, yet want your radio to be custom-made, with all the advantages that this implies, S-M will gladly refer your inquiry to an Authorized Silver-Marshall Service Station near you. If, on the other hand, you build sets professionally, and are interested in learning whether there are valuable Service Station franchises yet open in your territory, please write us.

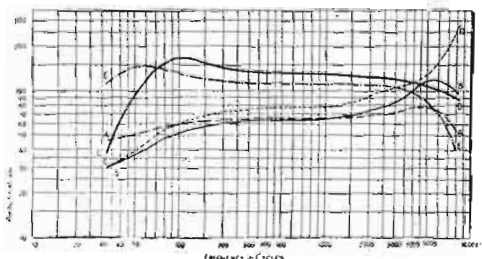

Silver-Marshall, Inc.
848 W. Jackson Blvd., Chicago, U. S. A.
..... Please send me, free of charge, the complete S-M Catalog.
For enclosed..... in stamps, send me the following:
.....(50c) Next 12 issues of THE RADIOBUILDER
.....(\$1.00) Next 25 issues of THE RADIOBUILDER
S-M DATA SHEETS as follows, at 2c each:
.....No. 1. 670B, 670ABC Reservoir Power Units
.....No. 2. 685 Public Address Unipac
.....No. 3. 740, 731, 732 "Round-the-World" Short Wave Sets
.....No. 4. 223, 225, 226, 255, 256, 251 Audio Transformers
.....No. 5. 720 Screen Grid Six Receiver
.....No. 6. 740 "Coast-to-Coast" Screen Grid Four
.....No. 7. 675ABC Power Supply and 676 Dynamic Speaker Amplifier
.....(50c) Sargent-Rayment Instruction Booklet
..... Name
..... Address

SILVER-MARSHALL, Inc., 848 W. Jackson Blvd., Chicago, U. S. A.

SM

SUREST SUCCESS for the SETBUILDER

IT is with unusual enthusiasm that Western Radio Manufacturing Company presents such sure-fire winners as the new S-M kits. Setbuilders looking for superior performance will find in them opportunities such as they have never had before.

The 720 Screen Grid Six

A glance at the illustration will prove that here is a set which, in appearance alone, is worthy to stand with factory products selling at several times the price. But look further into the Screen Grid Six—begin with the antique brass control escutcheon—examine the four tuned circuits—the new high-selectivity S-M 140 antenna coil—the rigid diecast gang condenser—the screen grid r.f. stages individually shielded in neat copper cans—and finally the marvelous new audio transformers, described on the opposite page. Then you will have some idea of the 720's overwhelming superiority in actual reception.

Try it. See these three screen-grid r.f. stages cut past a powerful local and reach out after a feeble signal a thousand miles away on the next channel (only 10 kilocycles difference!) and deliver it with loud speaker volume. And tone quality—well, it takes a vivid imagination indeed to get from the mere amplification curve on the preceding page, remarkable as it is, any idea of the glorious beauty which transformers like these impart to radio music.

So—when we get hold of a set carrying the S-M guarantee, and are able to offer it at a list price of only \$72.50 for the complete kit (the 700 cabinet is \$9.25 extra)—or the entire set custom-built in this cabinet and tested in the S-M laboratories at \$102.00—then we say it's a bargain. And while we hope to keep 720's always in stock, scarcity is coming—so we urge you to order yours now!

The 710 Sargent-Raymont Seven

A station tuned in for every ten kilocycles—a hundred stations heard in one summer evening, in the heart of Chicago interference—that is the performance record of the 710 Sargent-Raymont Seven—latest masterpiece of the inventors of the "Infadyne." The 710 is a precision laboratory instrument for the veteran fan. The thick aluminum shielding and chassis, finished in satin silver, give beauty of a strikingly appropriate type. Other features responsible for this unusual performance include five sharply tuned circuits in a four-stage screen grid r.f. amplifier, all tuned by a single illuminated drum, and provided with individual verniers. One knob controls volume from zero to maximum. There are no other controls. Each circuit is individually shielded, bypassed, and isolated from all others. New S-M transformers insure unbeatable tone quality. The set is a joy to build, so workmanlike is its design and layout.

The approved 710 Sargent-Raymont kit, manufactured exclusively by S-M, is priced at \$120.00 with cabinet.

A Station Every 10 Kilocycles:
The Sargent-Raymont Six

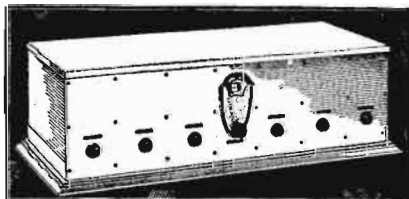

The 740 Coast-to-Coast Four

The new S-M Coast-to-Coast Four offers the finest performance yet attained with this remarkable circuit. A screen grid r.f. amplifier stage, regenerative detector, far finer coils than ever before, the new Clough high-gain audio system, and an all-metal assembly make a receiver which cuts through local interference only 10 or 20 kc. away. Unequaled tone quality, and an appearance (in the cabinet) identical with the 720 Six,—yet the price is only \$51.00 for the complete approved kit, with the 700 cabinet \$9.25 extra. The 740 goes together easily and simply, and will out-demonstrate ready-made sets selling at twice its price.

The 730 "Round-the-World"

Have you had your taste of the "thrill band"—the short wave band from 17 to 200 meters? Down there you can hear European broadcasting stations; chain programs through heavy static; television—the low-wave band is its busy nursery. You can hear amateurs in almost every country, all in one evening—if you have this neat, trim, snappy little receiver—four-tube regenerative (non-radiating)—with one screen grid r.f. stage and two of the S-M high-gain audio stages. Four plug-in coils fit instantly into a 5-prong socket on top of the aluminum cabinet. The complete 730 kit, including cabinet, is \$51.00; the 731 (same kit without the two audio stages, at \$36.00) converts any set to long-distance short-wave reception. The 732 Essential Kit, at only \$16.50, contains the two tuning and tickler condensers, the four plug-in coils, coil socket, and three r.f. chokes, with full instructions.

Choose whichever of the three kits you prefer, and step out into the "thrill band"!

The 1929 Laboratory Receiver

Three stages of screen grid radio frequency amplification, a screen grid first detector, two stages of 65 kc. screen grid intermediate frequency stages, and a super-powered second detector—all copper-shielded—working into an audio stage using the new S-M audio system—selectivity that makes stations literally snap in and snap out—and all under the control of two vernier drum dials, and a "volume" and a "sensitivity" knob. Just imagine a 65 kc. i.f. super, with all the tremendous amplification that this frequency (plus screen-grid tubes) gives! With the ultra-fine tone that can be gotten only with the new S-M audio transformers and a stage of external light-socket, push-pull 210 or 250 Unipac amplification—the highest-powered, finest-toned amplification money can buy!

The parts for this super, mostly of S-M manufacture, cost but \$95.20 complete, less cabinet at \$9.25 list. Outstandingly the finest superhetrodyne money can buy.

SEND FOR OUR FREE DEALER CATALOG AND DISCOUNTS!

We are offering, this season as always, America's biggest radio values. Mail the coupon at the right—it will bring you our big new catalog—FREE. Maximum discounts to dealers. Immediate shipments from stock.

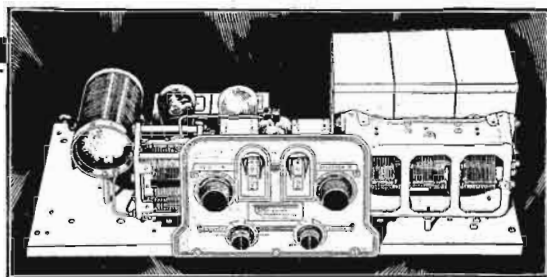

720 Screen Grid Six: The Year's Biggest Value!

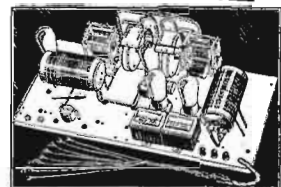

740 Coast-to-Coast Four: Best Money's Worth in the Fifty-Dollar Class

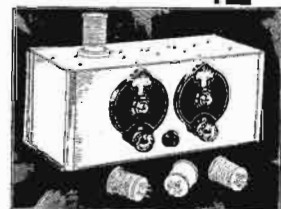

Five Continents in One Evening: 730 Short-Wave Set

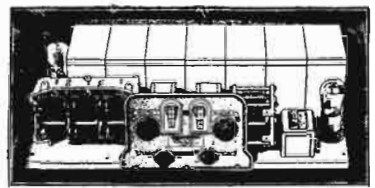

Nine Tubes with Screen Grid Efficiency: The 1929 Laboratory Super

WESTERN RADIO MANUFACTURING CO.

"The Big Friendly Radio House"

128 West Lake Street

Chicago.

Western Radio Mfg. Co. (Dept. SN-10)
128 West Lake St., Chicago

Please send your new FREE catalog, listing S-M parts and kits as well as many other highest-quality radio products.

Name.....

Address.....

PILOT PRESENTS NEWEST

Engineered, Built and Merchandised



Test-and-check is the motto of Pilot engineers who control production.

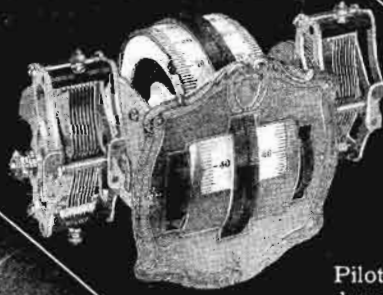

Pilot provides this handsome drum dial with fast and slow-motion wheels to make tuning quick and sure.



Illuminated knob-type vernier drum—built to Pilot precision standards.



Introducing a new family of moisture-proof bakelite case transformers—audio, push-pull and output transformers, output filter, B choke.



Universal A and B pack transformers, approved type for latest A. C. tubes and circuits.



Where Pilot Radio Parts Are Made.

PILOT ELECTRIC M'FG. CO.

323 BERRY ST.  BROOKLYN, N.Y. INC.

TRADE MARK REGISTERED

"WORLD'S LARGEST RADIO PARTS PLANT"

PRECISION RADIO PARTS By Radio's Master Craftsmen



This socket is made for UX and UY tubes. Pilot builds many other types for special purposes.



Engineers specify the Pilot shock-proof socket for A. C. and shield-grid tubes.



Skilled designers specify Pilot mid-gets for short wave as well as broadcast sets. Made in four capacities.

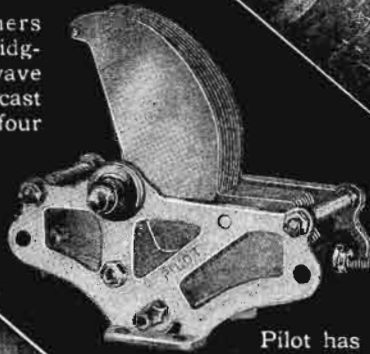

Pilot has made millions of condensers. That experience is built into the new Centraline and S. L. F. types.

Again Pilot scores with new features in the single, double and triple condensers, with compensators for balanced circuits.

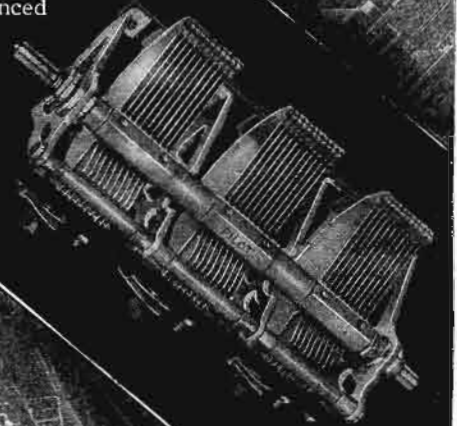

Other new Pilot parts shown in complete catalog.



Illuminated vernier — Pilot gives beauty and precision at lowest cost.

PILOT ELECTRIC M'FG. CO

323 BERRY ST.  BROOKLYN, N.Y. INC.

TRADE MARK REGISTERED

"RADIO MANUFACTURERS SINCE 1908"

OVER

PILOT Pioneers TELEVISION



Pilot's Television Transmitter

designed, engineered and built by world's largest radio parts plant. Now successfully transmitting nightly at Radio News station WRNY (326 meters). Illustration shows subject being televised. Inset illustrates amplification apparatus.

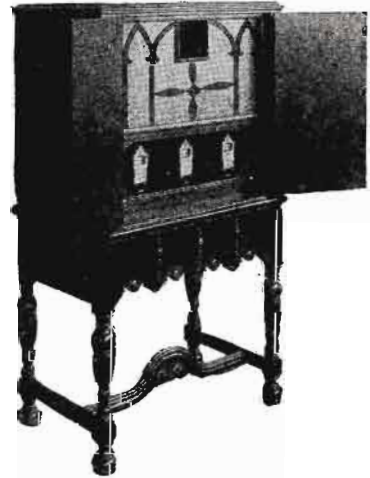

Pilot Television and Broadcast receiver used during first public television demonstration at New York University. Built entirely of standard Pilot radio parts plus Neon tube, Scanning Disc and Synchronous motor. You can assemble a Pilot television outfit for less than the cost of the average broadcast receiver! Write for information.

Television is Here!

In those three words, Pilot proclaims to a waiting world the miracle of practical, workable television.

Not laboratory television with expensive equipment, but *home television*, with no special apparatus except Neon tube, disc and motor. All other parts are *standard* Pilot radio parts—the kind you have always used.

To develop television on a practical basis, Pilot's engineering staff designed and built its own television transmitter. Hundreds of tests were made. Finally the official demonstration at New York

University before a brilliant group of distinguished scientists and engineers provided a fitting climax to the months of unremitting research.

Now each night unseen light travels the ether waves from the Pilot-built television transmitter permanently installed at radio station WRNY. To make sure of results, use only genuine Pilot parts!

Up to time of going to press, Pilot has released no specifications—therefore, dealers and fans are warned against unauthorized scanning discs and parts.

PILOT ELECTRIC MFG. CO.
 323 BERRY ST.  BROOKLYN, N.Y. INC.
 TRADE MARK REGISTERED
"WORLD'S LARGEST RADIO PARTS PLANT"

Send 4c in stamps for complete catalog containing complete data on all Pilot Radio Parts and Newest Apparatus.

This Coupon Brings You

four big issues of Radio Design—the live-wire quarterly edited by M. B. Sleeper, Chief Research Engineer of Pilot and Affiliated Companies. Radio Design is filled cover to cover with advance information especially interesting to radio engineers, custom-set builders and the man who builds his own. Enclose 25c Coin or Stamps.

Name.....
 Address.....
 City..... State..... R.N 10-28

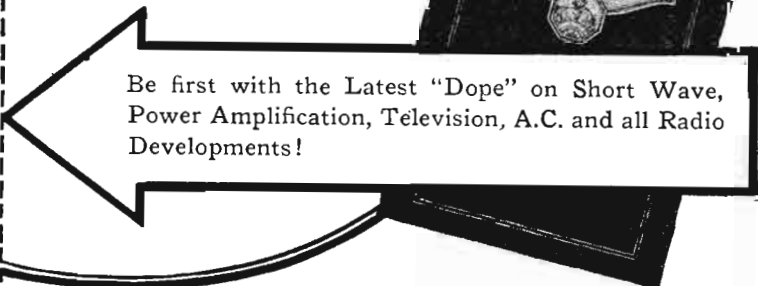

Be first with the Latest "Dope" on Short Wave, Power Amplification, Television, A.C. and all Radio Developments!

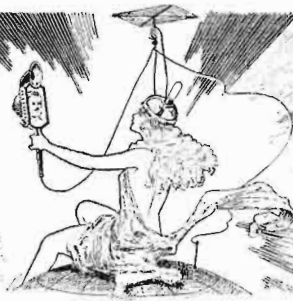

What is Coming in Television

By HUGO GERNSBACK

NOW that television has actually arrived, and a number of radio stations are already broadcasting television as a regular thing, it behooves us to look into the future and see what is likely to happen during the next few months and the next few years. It is a foregone conclusion that history will repeat itself, and that we shall have a boom in television, just as there was a boom in radio in 1921 and 1922. There are, however, certain differences that should not be overlooked and, if these differences are carefully studied, we will avoid the pitfalls and the disappointments which the radio industry had to contend with in the broadcast boom period.

To begin with, I cannot repeat too strongly my previous admonition that television at the present time, and for some months to come, is not for the public at large. It is doubtful whether, for some years to come, television sets will be sold as radio sets are now sold, direct to the public. The problem of synchronization has not, as yet, been solved completely, although much valuable work along these lines has already been accomplished. The idea of "You push the button, we have done the rest," is not yet true in television.

Television just now is in its earliest stages of infancy, and may be compared to radio at its coherer and spark-coil stage in 1903. It took almost twenty years from that period for broadcasting to come about. Of course, the cycle at this time will be shortened considerably; but even the most optimistic today doubt whether television will be ripe for the general public within two years, at least.

In the meanwhile, it will be paradise for the experimenter and the amateur who will "build their own"; who will experiment, who will improve and do a thousand and one things to make television practical from the public's standpoint. For some time we will have the rotating disc and the neon lamp with us. As I have said before, editorially, this is only a transitory stage during the development and, in the end, the disc with its motor will not prevail. But at the present time we have nothing better; and the disc really does give results and is making, at least for the present, television practicable for us. What instrumentality we will be using for television one or two years hence, no one knows; but that does not matter. Every art has to go through its stages of development, during which a great deal of information must be gathered, and the keenest minds in the art concentrated on the problems; but from such beginnings the art will slowly evolve into greater and broader accomplishments.

As in the early days of broadcasting, hundreds and thousands of concerns will rush into the production of all sorts of television material, and a good start has already been made while this is written. A great deal of good material and probably much more poor material will be turned out by these concerns in the scramble for supremacy; but, just as in all other endeavors of this kind, it may be freely predicted that those with the best technical talent, and those who serve the public best, in an economic sense, will probably remain in evidence after all the others have been left by the wayside.

TELEVISION
MEANS
INSTANTANEOUS
SIGHT
AT A
DISTANCE

Particularly with television, a great deal of caution is necessary before any material is put out at all. Manufacturers should not rush into the market with half-baked production and with material that is not scientifically and correctly designed. Radio during the broadcast boom came in for a good deal of adverse criticism; because, seemingly, every shoemaker became a radio manufacturer over night and turned out the most impossible and incredible contraptions, which did not last for more than two months. It will probably be the same with television.

Already, in New York and other cities, small temporary booms have been created artificially by irresponsible retail establishments who sold "television" (?) material which is, in the first place, unfitted for use, and secondly, even though it had been all right, could not have been used because no one was broadcasting television impulses at that time. These practices only react against the merchants themselves, because, when a legitimate demand comes along, those who have been previously deceived and disappointed will probably be most cautious in investing their money in new devices.

The public at large should know that television is purely an experimental art at the present time and only those handy with tools and proficient in radio and general science should attempt to build a television receiver. Pretty soon, many television kits will be offered for sale; but even such kits, no matter how well made, are only for the experienced radio constructor and those mechanically and electrically inclined and handy with tools, and not for the general public.

The television fan should know, without being told, that results to start with will not be any too good. Unless you are within twenty miles of a transmitter, conditions are not apt to be favorable. Such a thing as receiving DX television, for the time being, seems doubtful; unless you can be satisfied to receive only occasional snatches of an image, or when it is impossible to distinguish a man's hand from a woman's face. In television today, we require a strong impulse and, even then, reproductions are apt to be not too good.

In the reception of radio broadcasting, the ear is not as sensitive to slight disturbances and variations as the eye. Static disturbances, battery trouble, loose connections, faulty synchronization of the disc, all tend to make for a poor picture and, for some time, it will be the general rule that the received images are, and must be, rather poor, except when you are very close to the transmitter. For that reason, television, wonderful as it is, even at present, should not be glibly talked to the public; and the public should not be led to believe that, next month, they will be able to purchase perfect television sets through which they can witness a ball game a thousand miles away, down to its most perfect details. That accomplishment, as yet, is in the indefinite future.

Let us go slowly, methodically, and the television art will grow into a tremendous thing. Let us keep our heads and not expect the impossible. Evolution in any art is a slow and orderly process. Let us bear with the necessary delays in perfecting television.

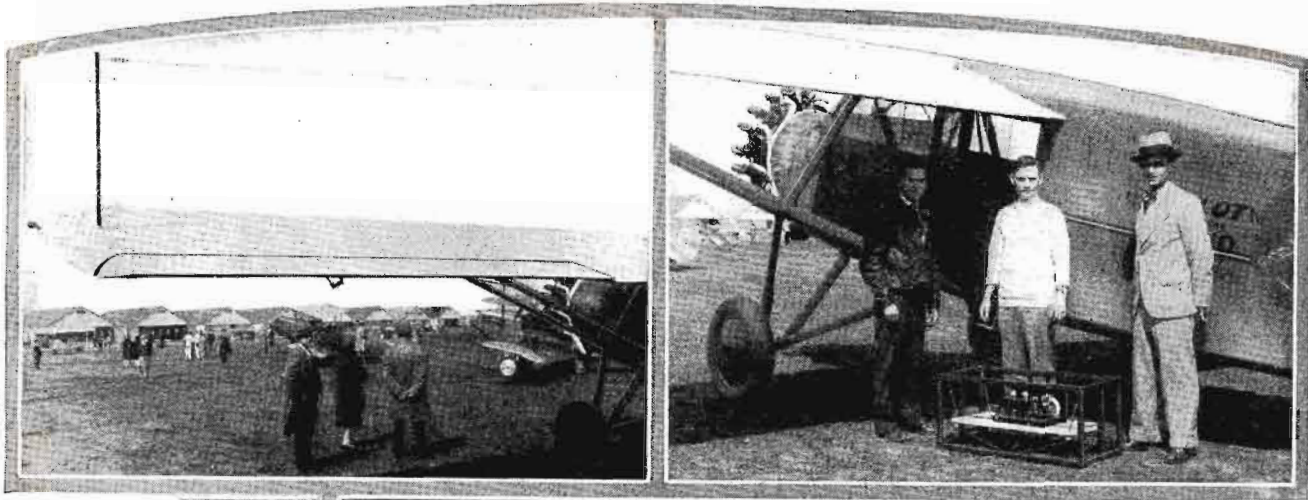

Above: How a fixed aerial is stretched across the wings of a monoplane. The wire is supported by short steel tubes set in special sockets in the wing tips. This type of aerial is intended to replace the trailing wire usually used for airplane radio work, which hangs beneath the body of the plane during flight and is a real source of danger; in that it may tangle in the control wires of the plane or catch on a tree or other obstruction if the radio operator or observer should fail to reel it in before a landing is made. This fixed aerial has the further advantage that it allows uninterrupted communication if the plane should make a forced landing in a deserted spot.



Above: The crate at the feet of the three men holds an experimental receiver hung on springs, the object of which is to protect the apparatus from the strong vibration of the plane's engine. The elimination of microphonic noises in the receiver is one of the main problems with which airplane radio engineers are faced. Left: Milton B. Sleeper, research engineer of the Pilot Electric Mfg. Co., of New York, testing the aforementioned receiver in the cabin of a six-passenger Stinson-Detweiler monoplane used by this company exclusively for experimental radio work. The plane is licensed under the call letters 2XBQ, and may frequently be heard transmitting on 40 meters, in code.

The Radio Laboratory Takes Wings

How the United States Army and Commercial Radio Companies Do Their Experimenting with New Airplane Radio Apparatus in the Sky.



By S. R. Winters



THE floating radio laboratory found on ships and other ocean-going vessels; the field radio laboratory which is carried from point to point on a motor truck; and even the portable radio equipment transported on a man's back, are no longer novelties because of their widespread usage. But the Air Corps of the War Department, in keeping with the spirit of this age of aviation, has introduced the "flying radio laboratory," a new contribution to the facilities of radio research; withal, complete transmitting, receiving and testing equipment on "wings."

An airplane, a Fokker C-2, has been converted into a workshop for radio research; the cabin of this plane being specially outfitted for the accommodation of sending and receiving equipment and for the carrying on of experiments during the course of flight. We learn best by doing, is an adage applicable to both flying and radio training, and a modification of this truism gives virtue to the contention that knowledge of aircraft radio is best obtained under actual service conditions, with the radio sending and receiving outfits studied while the

airplane is in flight. Commercial radio companies, imbued with a like belief after seeing Uncle Sam's "flying radio laboratory," are planning duplications of the facilities whereby new radio apparatus may be subjected to complete tests in the air.

The Air Corps flying radio laboratory includes at least two complete transmitting stations and five different designs of receiving sets. One of the transmitters, identified as type SCR-123, derives its power supply from a double-voltage generator, (1,000 volts—0.5 ampere, 15 volts—20 amperes), connected to the right outboard engine; also from the standard power installation consisting of a 50-ampere generator on the left outboard engine, battery and dynamotor Type BD-41. The other transmitting set included in this laboratory on wings is a short-wave outfit, operating on a band of wavelengths from 75 to 100 meters. The source of energy for this short-wave transmitter is a 2,000-volt, 0.4-ampere French wind-driver generator, mounted on the left side of the fuselage.

The radio receiving equipment in this flying laboratory includes a variety of de-

signs: those approved for aircraft communication as well as new designs, now in the stage of development and awaiting future approval or disapproval, as flight tests may determine. Among the approved outfits are types BC-115 and 116, developed by the Signal Corps of the War Department, which were used in early radio-telephone broadcast reception between a broadcast station in Chicago and an airplane, as well as in communication tests between aircraft and ground radio stations. Of the experimental receivers, this laboratory on wings carries one model each of two airplane receivers now in the process of development by the General Electric Company and the Westinghouse Electric and Manufacturing Company. In addition, the equipment includes a type of receiver known as BC-137, and a short-wave super-regenerative receiving set, also a new design of the General Electric Company.

The maiden journey of this radio laboratory on wings—from Dayton, Ohio, to Buffalo, New York, and return to Dayton by way of Schenectady, New York, Mitchell Field, New York, and Bolling Field, Wash-

ington, D. C., is described interestingly by Captain Paul S. Edwards, a radio engineer of the Signal Corps, in a letter to the Chief Signal Officer of the U. S. Army, Major-General William S. Gibbs.

STORY OF THE FLIGHT

"The radio beacon at Dayton was laid on the course for Buffalo," reports Captain Edwards. "The keying system of the beacon utilized the new interlocking system where dots are sent on one loop and dashes on the other loop with continuous full-power 1,000-cycle note. The beacon was heard throughout the entire trip to Buffalo, a distance of 349 miles. Two-way telephone communication was maintained between the airplane and the ground station at Wright Field for a distance of over 262 miles.

"Just before reaching Dunkirk, New York, both stations switched to interrupted-continuous-wave telegraph transmission and exchanged messages until landing at Buffalo. Upon departing one hour later from Buffalo, both stations worked for about twenty minutes, but the noise level was so increased that, while the signals were audible, they were not readable. We arrived at Schenectady 5:30 P.M. same date. The weather throughout the flight was clear, with the exception of Buffalo, which was slightly overcast with light fog.

"During our stay at Schenectady several flights were made with engineers of the General Electric Company as passengers, who observed the operation of the equipment in the airplane and tested a new type of super-regenerative receiver between Albany and Schenectady, where the ground station utilized an output as low as one watt. This receiver, in operating condition, worked very well, but at the present stage of development is not considered suitable for military use; as there is no standby adjustment and the critical tuning necessary to obtain signals renders it unfit for aircraft use. The G. E. engineers also demonstrated a new type of short-wave receiver, using one stage of UX-222 radio-frequency amplification, detector and two stages of audio-frequency amplification. The results were so remarkable on this receiver that one was purchased for the Signal Corps Aircraft Radio Laboratory, with a view of using it as a standard of performance for aircraft short-wave receiver development.

FROM NEW YORK TO WASHINGTON

"Departing from Mitchel Field, en route to Bolling Field, a schedule with WYB,

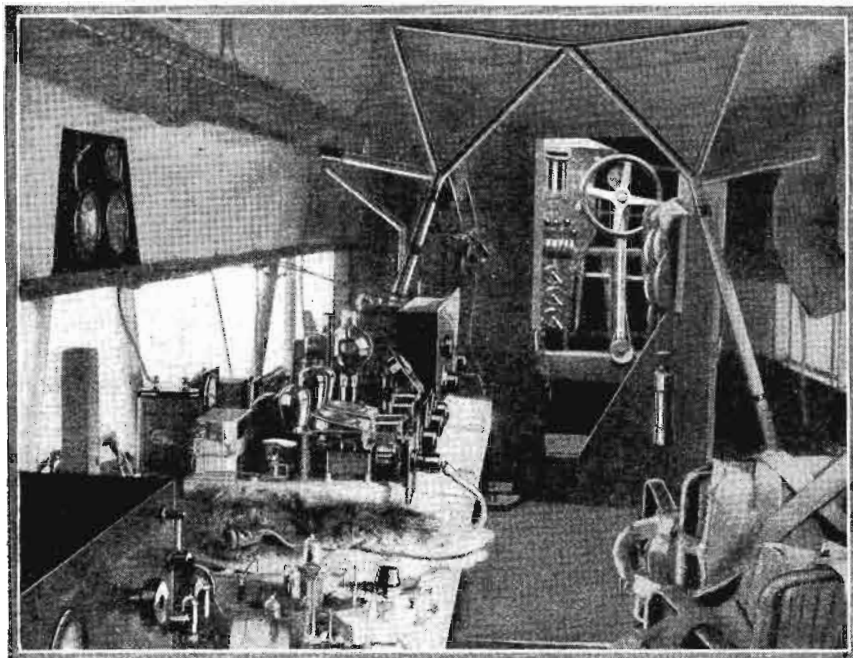

The cabin of the Army airplane, showing part of the extensive radio equipment which is tested under actual flying conditions. Electrical and mechanical deficiencies in any piece of apparatus are quickly discovered during a flight.

Bolling Field, an interrupted-continuous-wave was maintained throughout the flight. Due to delay in delivering the message of take-off, communication did not commence until we had reached Trenton, N. J., but signals at that distance were of such strength that it could have been easily possible to have secured two-way communication from both fields. Due to the fact that the Bolling Field transmitter was not in commission for telephone transmission, all messages were sent and received by interrupted-continuous-wave.

"A flight was made from Bolling Field to Baltimore, and return, using voice and interrupted-continuous-wave throughout the entire trip between the airplane and Bolling Field. The airplane took off from Bolling Field, en route to Langley Field, for the maneuvers, carrying Lieutenant Wolfe as pilot, Captain Edwards, Mr. Knott, and Congressman James and Hoffman. Messages were exchanged throughout the trip until just before landing at Langley Field. On the return trip from Langley Field, ar-

rangements were made to work the Bombardment Squadron SCR-132 (DO 1), and Bolling Field was also advised of our departure. Throughout the trip, communication was maintained with both ground stations and the airplane. Congressmen James and Chapplin and Judge Clay were passengers on the return trip.

"Arrangements were made for a flight over Washington, carrying seven people: Assistant Secretary of War Davison, Mr. Adamson, Major Blair, Signal Corps, Major Davison, Air Corps, Mr. Knott, Captain Edwards and Lieutenant Wolfe. The Assistant Secretary of War was given a demonstration of broadcast telephone reception while in the air. He also transmitted telephone messages to Mrs. Davison who listened in at their home. Radio-telephone communication was established with Bolling Field, and messages were exchanged between the Assistant Secretary and the operator at the ground station.

"The airplane departed from Bolling Field
(Continued on page 370)



The huge tri-motored monoplane which the U. S. Army has outfitted as a flying radio laboratory. Much valuable information on the behavior of radio apparatus under flying conditions has been obtained by army engineers during flights in this big ship.

“Wired Wireless”--What It Is and Why



How Radio Principles are Applied to the Transmission of Four Telephone Conversations or Ten Telegraph Messages Over a Single-Wire Circuit



By J. E. Smith*

WHAT a title! And yet some of the old-timers who “pounded the brass” back in the days of the spark-gaps will be able to appreciate it. For radio was then “wireless.” From that time to the present we have always understood the word to mean *wire-less*, and have extended this self-same idea of late years to the term “radio.” But where is the sense of such a title?

Well, the whole fact of the matter is that “wireless” is becoming less wireless nowadays. For quite some time we have been transmitting messages and concerts through “space” without intervening wires—hence *wire-less*. But it now happens that we are doing likewise through wires, and not through vacuous space.

Some of you know what is in the wind; others are guessing; and still others haven't the slightest inkling of what this article is about. But to drag the dusky gentleman from behind the foliage, let it be known that at the present time great developments are going on in connection with the transmission of intelligence over metallic circuits of wire *at radio frequencies*. Therein lies the secret; we are all well acquainted with the transmission of speech in the ordinary manner over the telephone. Such speech is transmitted at its own frequencies, namely, tones varying from about 200 cycles per second to about 2,000 cycles, in commercial practice. It has been found very practical, for reasons which shall be unfolded as we proceed, to transmit speech *over wires at radio frequencies*, in much the same manner that today we are transmitting through empty space, programs from the broadcast studios.

USING WIRES TO THE LIMIT

This matter of utilizing a carrier wave for the transmission of speech is not new. The beginning of the work dates way back in the nineties, and is due to such men as Pupin, Leblanc, Hutin, Squier, Stone and

others. Then, later on, we may include DeForest for his wonderful contribution, the vacuum tube, G. A. Campbell for his electrical filters, and many more.

Telephone systems in use at the present time furnish simultaneously as many as *four two-way telephone conversations over each line* in addition to the telephone and telegraph facilities normally afforded by the circuit. Other systems are arranged to furnish *as many as ten duplex-carrier telegraph circuits over each line*, in addition to the usual facilities. Think what

this means! Without stringing up more wires on poles, or laying them in conduits under the street, it is possible to multiply the number of channels of communication by five, ten, twenty—who knows how much.

The general principles involved in carrier-current communication are fairly well understood by many of our radio readers. We encounter it every day, in operating our radio receivers or, if we are “hams,” our transmitters. Suppose we start at the transmitting station. First, we have an oscillator, which generates the radio-frequency currents. Next, we have a microphone into which the performer sings or speaks. The speech (audio) frequencies are amplified by the speech amplifier and pass on into the modulator tube, into which at the same time is passing the radio-frequency current from the oscillator; so that the modulator is really a “mixing” tube. Next, from the modulator, the mixed currents may pass through an amplifier and thence to the transmitting antenna and off into space. (See Fig. 1.)

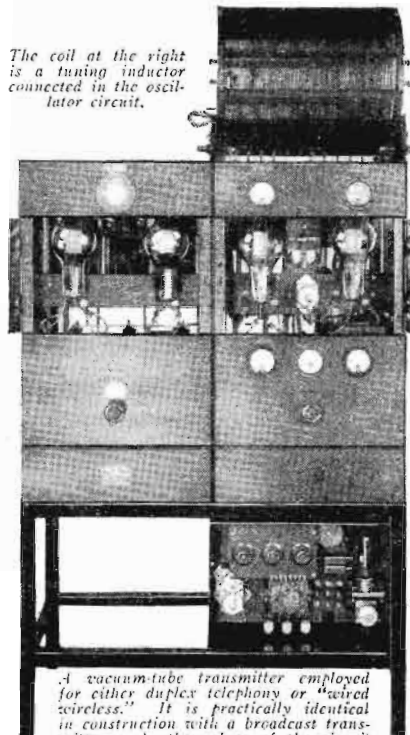

The coil at the right is a tuning inductor connected in the oscillator circuit.

A vacuum-tube transmitter employed for either duplex telephony or “wired wireless.” It is practically identical in construction with a broadcast transmitter; only the values of the circuit components being different.

MODULATION AND SIDEBANDS

The most interesting point of the system is the frequency. The oscillator may be generating power at a frequency of a million cycles a second; the speech frequencies range from perhaps 30 cycles to 10,000 cycles. After being mixed in the modulator these frequencies are considerably changed, and instead of two frequencies we have many. The most important of these are known as the “carrier” frequency and the two “sideband” frequencies.

In order to make this clear, let us suppose that instead of singing or talking we play on a flute in front of the microphone a single sustained note with a frequency of 1,000 cycles (per second). Also, suppose that the “carrier” frequency is 1,000,000 cycles. The two side frequencies are then 1,001,000 and 999,000 cycles, representing the sum and the difference, respectively, of the carrier and the modulating frequencies. The same rule holds when there are a number of frequencies coming from the microphone, and in general, we will have a situation somewhat as represented in Fig. 2. We have the carrier at 1,000,000 cycles; the upper sideband, ranging from 1,000,030 to 1,010,000 cycles, and the lower sideband, ranging from 999,970 to 990,000 cycles.

This mixture of frequencies passes out through space to the radio receiver. Here they are first amplified in the R.F. amplifier; next they pass into a “demodulator,” more generally known as a detector. In the detector or demodulator the complex radio-frequency currents again suffer a change of frequency, and we finally have left only the original audio frequencies, amplified by the A.F. amplifier and changed into sound waves by the loud speaker.

All of these phenomena can be very readily adapted to the transmission at radio

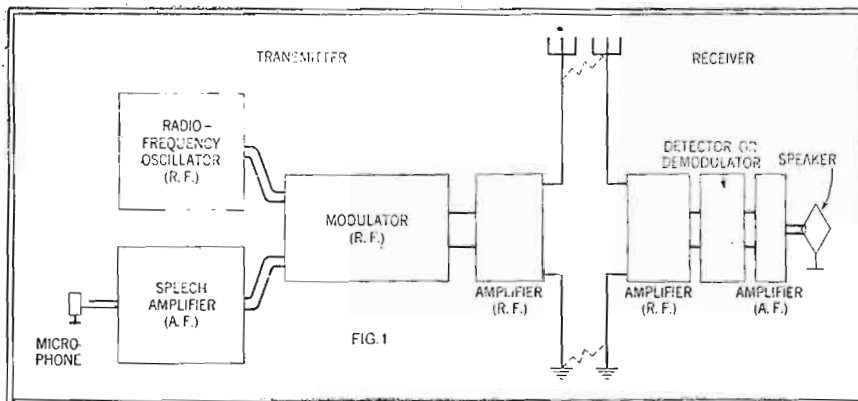

This diagram shows the fundamental units employed in a radio-broadcast transmitter and a receiver, respectively. A sound made before the microphone, on the left, is reproduced by the loud speaker, at the right.

* President, National Radio Institute

frequencies over wires, instead of through space. It would be a very simple matter to simply string up a pair of long wires where the dotted lines are shown in Fig. 1, and thus connect the transmitting and receiving stations by a complete metallic circuit.

MULTIPLE TRANSMISSION

The main advantage attached to such a system would be privacy; but unfortunately, it would be a very expensive proposition, and certainly not a profitable one for the telephone company, if they wished to supply service in a manner similar to the service they now supply us, and at the present rates. It is extremely expensive to construct telephone lines, so that the main advantage of such a system lies in the ability to adapt it to the existing lines, and by means of the selective circuits, carrier-currents modulated by speech can be tuned to resonance in exactly the same way as we tune in one station or another on our receiving sets.

For example, it is easy to imagine that a number of oscillators, each one oscillating at a different radio frequency, being modulated simultaneously by a different microphone, are connected to the same pair of wires. Then, at the other end of the line, we can imagine a number of radio receivers, each one tuned to a different frequency. It is clear that each current wave could be tuned in without experiencing interference from the other, in exactly the same way as we tune in WJZ and tune out WOR, or vice versa. Not only that, but it is not necessary for all of them to be modulated by speech; some of the "channels" may carry speech, some may carry music, others may carry telegraph code, another may control tickers, and what not.

The number of such "channels" which are possible in a single circuit of wire is very great, and depends mainly on the width of the sidebands. For example, in the case illustrated by Fig. 2, in which we are supposing music to be transmitted, the sidebands are 10,000 cycles wide, making it necessary to have a channel 20,000 cycles wide. This is a very wide channel. Generally, intelligible speech requires a band only about 4,000 cycles wide, and music a band-width of about 10,000 cycles.

LOW CARRIER FREQUENCIES

However, before going much farther, it may be well to state that such frequencies as a million per second are not used in carrier telephony or telegraphy; for the losses in the wires and in the associated apparatus at these frequencies would be too great. Therefore, commercial carrier frequencies generally lie between 10,000 cycles and 50,000 cycles. This then permits only five bands 10,000 cycles wide, theoretically; practically, it is possible to squeeze in five such bands only by employing special means for doing so. The Campbell filter makes it possible to cut these bands off sharply, so that they do not interfere with adjacent bands. Such a filter consists of a series of sections, as shown in Fig. 3, consisting of coils and condensers, and so tuned that the "cut-off" is very sharp; it can be so designed as to pass any desired band of frequencies. The filters are connected between the line and the receiver, so that the receiver can receive energy only at the frequencies determined by the filter.

Of course, there are many difficulties to be overcome in such systems; there are the same problems that are found in ordinary

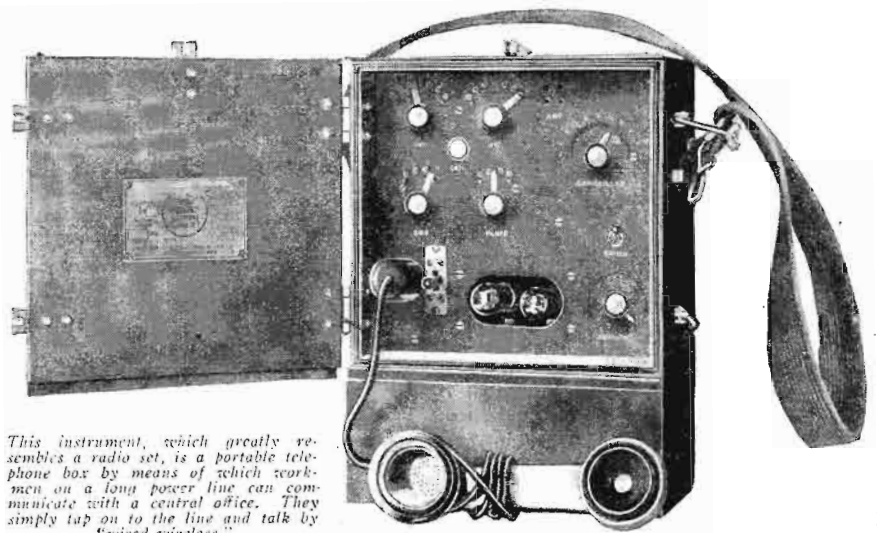

This instrument, which greatly resembles a radio set, is a portable telephone box by means of which workmen on a long power line can communicate with a central office. They simply tap on to the line and talk by "wired wireless."

telephony, and others besides. There is the usual trouble of interference, the trouble of cross-talk, that of "singing," and so on.

SINGLE-SIDEBAND TRANSMISSION

As another means of conserving the channels, it has been found possible to eliminate not only one of the sidebands, but the carrier frequency as well, in certain special cases. For instance, in Figure 2, none of the speech frequencies are included in the carrier; they are included only in the sidebands. Furthermore, since the side-

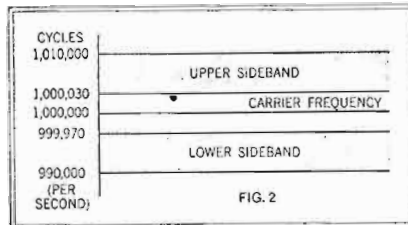

FIG. 2

When music is transmitted over a "carrier-current" system, the sidebands are quite wide, as shown above.

bands are identical in range, why not eliminate one of them? This has actually been done, by applying the Campbell filters at the transmitter, so that they eliminate one band and the carrier, and permit the other band to pass through. When this is done, it is necessary to "supply" a carrier frequency at the receiver, so that amplification and detection can be carried out in the usual manner. This is admirably accomplished by the superheterodyne type of receiver, in which the oscillator of the "super" furnishes the carrier frequency. It is clear that cutting off a single side-

POWER-LINE PROBLEMS

It is clear how this may be done in the case of alternating-current power; for this can be transmitted at a certain particular frequency, say 60 cycles, and occupy its own channel (with no sidebands in this simple case) just as each band of speech frequencies or telegraph code occupies its own channel. And, going still a step farther, it is clear that constant or direct current can be just as easily transmitted along with the communication channels; for direct current has a frequency—zero—and oc-

An arrangement of coils and condensers such as that shown at the right constitutes a "filter" which can be adjusted to pass only a definite band of frequencies, to the exclusion of all others.

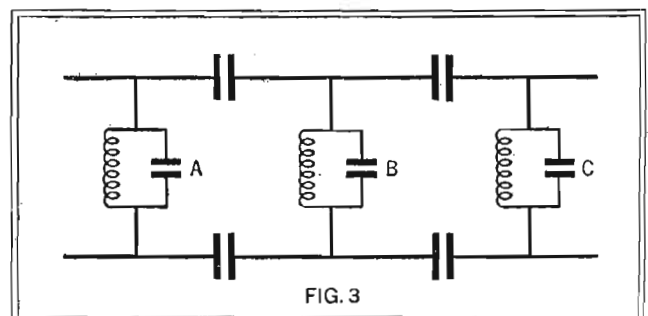

FIG. 3

copies its own channel of zero frequency.

However, when we come to the matter of transmitting intelligence over power lines operating at high voltages other problems arise, the most important of these being the manner in which the transmitter and the receivers of the carrier currents are connected to the power lines. There are two methods of doing this; one of these is shown in Fig. 4, where the transmitter or receiver is coupled to the power lines by high-voltage condensers of small capacity, these two being connected to a protective ground connection. Fig. 5 shows the other method, which consists merely of stringing a pair of wires parallel with the power lines for a distance of a thousand feet or more. These wires act exactly like antennas. In addition to the difficulties of properly insulating the system in these high-voltage power lines, others are encountered. For instance, where "sectionalizing" switches in the lines are opened, it is necessary to erect what might be termed "by-pass antennas" in order that the carrier currents may pass over the gap. This incurs losses, to be sure, but at least the gap is bridged, and it is necessary only to increase the power of the transmitter sufficiently to overcome the loss.

Another difficulty encountered occurs when great loads are thrown on the power lines, as when large mills are running, or at night when the lighting load becomes great. The short-circuiting effect produced by the turning-on of so many feeder lines causes changes, in the characteristics of the lines, which make it necessary to employ more power in the transmitter at such times.

And, finally the carrier-current system is being used successfully as a means of communicating from moving trains. In this case, the antenna wires are strung along

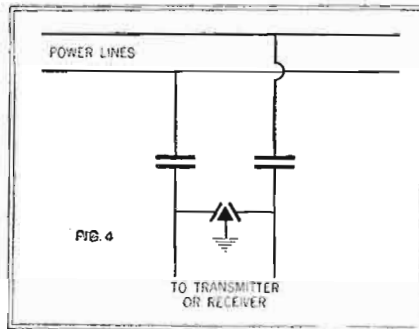

FIG. 4
Two methods of coupling a "carrier-current" communication system to a high-voltage power line. Above, condensers are used, with a grounded protective device. Below, an inductive connection is made by antennas strung near the power wires.

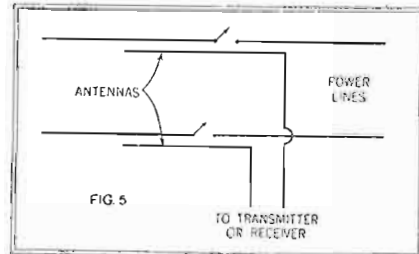

FIG. 5

the tops of the cars, parallel with the telephone wires along the road. (See page 1936, Radio News for June, 1926.)

BROADCASTING OVER WIRES

The principles of "carrier-current" transmission have been successfully applied also to the "broadcasting" of voice and music over electric power lines and the reception of the programs in the home via the lamp socket. A large power company has been experimenting in this direction for the past five years, and has furnished regular entertainment, on a limited scale, to a number of communities. The scenes of these experiments have been Staten Island (part of the city of New York), a section of Washington, D. C., and a small town in Illinois.

The entertainers appear in a regular broadcast studio and perform in front of the usual microphone. The program is then put on the power wires instead of being broadcast through the air. Three or four programs of different nature can be transmitted simultaneously, on different frequencies.

The receiver is a very simple affair, containing only a few tubes and a switch to select any one of the several available programs. It is plugged into any lamp socket, from which it derives, not only the music, but also the power to operate the tubes.

FIXED-TUNE RECEIVERS

Electrically, the receiver consists merely of three or four circuits permanently tuned to the frequencies on which the separate programs are transmitted. A switch is provided to enable the user to select whichever program he wants. There is no extensive tuning to be done, as the reception is entirely limited to what the power lines carry. A loud speaker of standard construction is employed for reproducing the programs as actual sound.

From time to time, during the past few years, newspapers have carried announcements that this system is "about to be inaugurated on a national scale"; but in spite of the size and wealth of the companies in

back of the scheme, nothing has yet come of it. The reasons are not difficult to understand.

In the first place, the number of available programs is limited; so that if a person should not like any of the three or four being transmitted, he would simply have to turn the receiver off. This shortcoming is emphasized by comparison with the great freedom of choice which the owner of a regular radio receiver has. Then again, a special receiving instrument is necessary. It has been evidently the plan of the power companies to rent the instruments on a monthly basis, and to make the system so complicated that it would be difficult, if not impossible, for the home constructor or custom radio builder to make a receiver of his own. The income derived from the rental of the machines was to be used for the payment of the entertainers.

WHY IT FAILED

Possibly the whole plan would have been very successful if radio broadcasting, as we know it today, had not flourished so well. With so many good broadcast stations on the air, at all hours of the day and night, and with good radio receivers available at low prices, it is doubtful if many people would care to buy or rent an apparatus that would furnish only limited entertainment during limited periods. However, since the power companies have not definitely stated that they have dropped the scheme, it may be realized some day.

Similar in principle is an application of "wired wireless" reported from Austria. Programs from a studio in Vienna are carried by telephone wires part of the way to the transmitter; but for over a hundred miles high-voltage lines are used for the circuit.

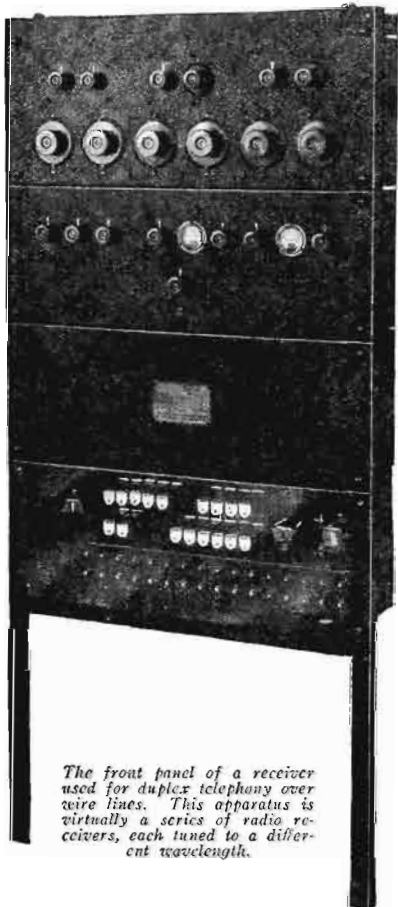

The front panel of a receiver used for duplex telephony over wire lines. This apparatus is virtually a series of radio receivers, each tuned to a different wavelength.

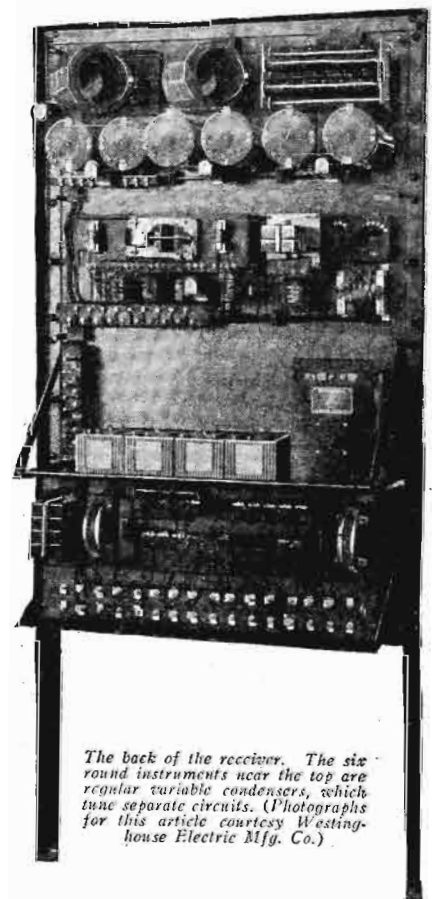

The back of the receiver. The six round instruments near the top are regular variable condensers, which tune separate circuits. (Photographs for this article courtesy Westinghouse Electric Mfg. Co.)

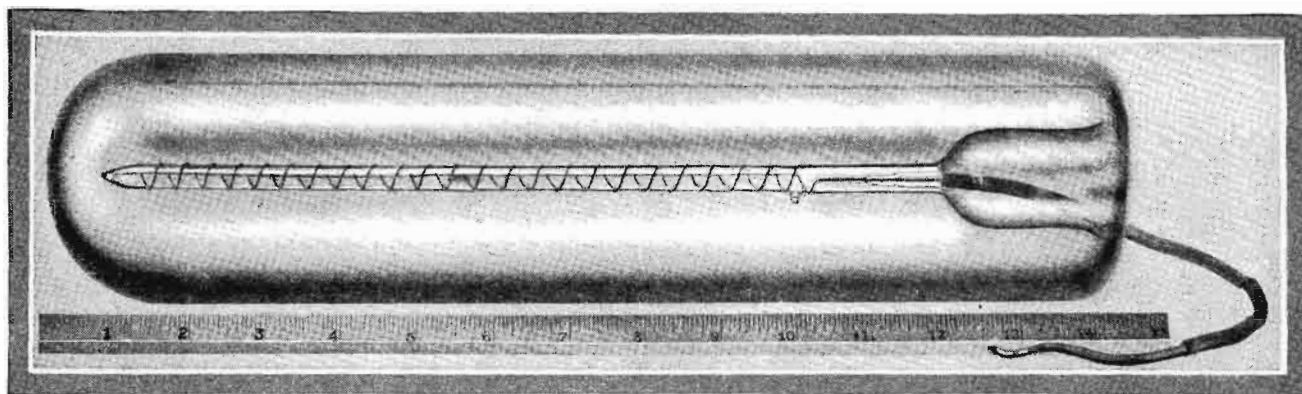

A close-up of a 14-inch photoelectric cell of the type used in television transmitters.

(Photograph courtesy Bell Telephone Laboratories)

The Photoelectric Cell—Radio's "Eye"

An Elementary Description of the Device That Translates Light into Electrical Current and Makes Television and "Talkies" Possible



By Dr. Lewis R. Koller*

Research Laboratory, General Electric Co.

PHOTOELECTRICITY treats of the relationship between light and electricity. The photoelectric cell is a vacuum-tube device by means of which light can be made to control an electric current. It has a great many uses in purely scientific work; and its applications include television, talking moving pictures, photometry, cigar sorting, control of paper quality, control of sign and street lighting, and many more.

The modern photoelectric cell is a comparatively recent development. Its forerunner was the selenium cell. The element selenium was discovered by the Swedish chemist, Berzelius, in 1817. In 1873 an Englishman, Willoughby Smith, attempted to use selenium in making high resistors for use in transatlantic telegraph work. He found that these resistances were very erratic and changeable, and eventually dis-

* From a paper presented before the Radio Division, National Electrical Manufacturers Association Convention, at Chicago, June 7, 1928.

About This Article—

AS the heart of practically all present-day television systems is the photoelectric cell, every radio fan who expects shortly to build a television machine should know something about the cell's characteristics and about photoelectricity in general. Here is a good non-technical article which explains in understandable language the fundamental principles of the device; read it and keep abreast of the times.—EDITOR.

covered that this was due to the fact that the electrical resistance of selenium depends upon the amount of light falling upon its surface; the brighter the light, the lower the resistance of the metal. He was able to get around his difficulties by enclosing his resistors in a light-tight box. Following this discovery, cells were constructed of many different forms to make use of this

interesting property. The selenium cell is still in use for some purposes, although it has many undesirable properties.

DISCOVERY OF THE EFFECT

The action of the type of photoelectric cell that I am going to describe, however, is radically different. The underlying principle was first made clear by the German physicist, Hallwachs, in 1888. The first observations of photoelectric phenomena were made by the pioneer in the field of radio, Heinrich Herz. He was conducting his famous experiments on electromagnetic waves, and did not pause to investigate the subject further. He merely mentioned it in one of his papers, and it remained for Hallwachs to study the phenomena in detail. Hallwachs found that if he charged a zinc plate to a negative potential (by connecting it to the negative terminal of a battery) and then exposed it to ultra-violet light, it gradually lost its charge. When he exposed the plate in the same way, after first raising it to a positive potential, it did not lose its charge. This phenomenon has been thoroughly investigated and it has been found that practically all substances exhibit it to a greater or lesser degree. This is the fundamental phenomenon of photoelectricity.

Hallwachs used a polished disc of zinc, $3\frac{3}{8}$ inches in diameter. In front of this was a large shielding plate of zinc (24 x 28 inches) with an opening in which could be placed windows of various materials. The zinc disc was illuminated by the light of the arc lamp in front of the windows. The gold-leaf electroscope connected to the disc told what was happening to the charge on the plate (Fig. 1.) When it was charged with electricity, the leaves stood out away from each other and, as the charge leaked off, the leaves gradually collapsed. Hallwachs found that, when the plate was negatively charged, the electroscope's leaves remained stationary until light from the arc fell upon the plate. They then began to droop, showing that the charge was leaking off the plate. No such change was observed when the plate was positively charged.

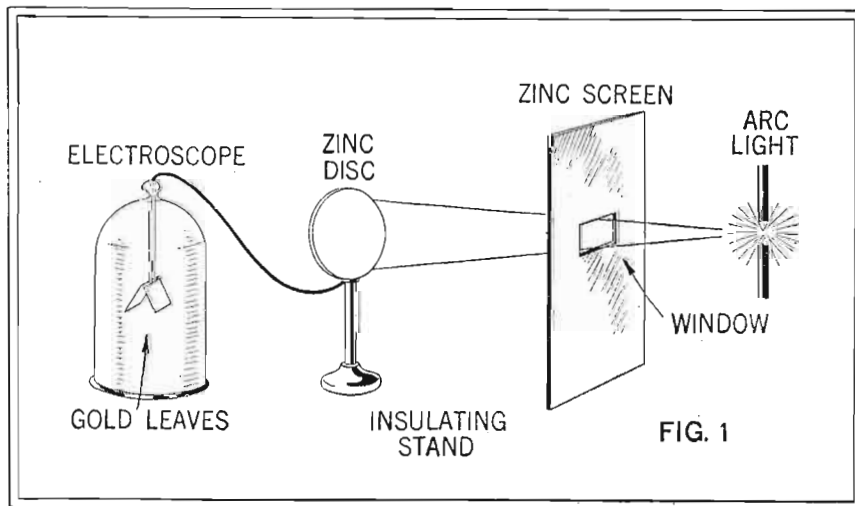

How the German scientist Hallwachs studied the effect of light on the electrical properties of a zinc plate. With the aid of this simple apparatus he made clear the fundamental principles of photoelectricity.

The explanation in terms of present-day physics is simple: The light which is absorbed by the photo- (light-) sensitive surface causes the emission of electrons or negative charges. If the plate is negatively charged to begin with, these electrons are able to escape and so the plate loses its charge; while, if it is positively charged, they are unable to escape because of the positive potential of the plate and the plate remains charged.

WHAT ARE ELECTRONS?

Perhaps before going further into the subject it would be well to say a little about the electron and modern views of the constitution of matter. The earliest conception of the atom was simply the smallest particle of matter that could exist. If one took a small piece of matter and cut it in two; took one of the halves and cut that in two, and so on, eventually one would reach a very tiny piece of matter that could not be any further subdivided. This was the atom. Now, through the work of Thomson, Rutherford, Bohr and many others, we have a picture of a vastly-different structure which has much evidence to confirm it.

Atoms are now believed to be small planetary systems with a massive nucleus in the center like our sun, and rotating about this center a number of electrons like the planets. The nucleus, which carries the positive charge, is made up of atoms of hydrogen, or "protons" packed closely together. The electrons are nothing other than negative charges of electricity.

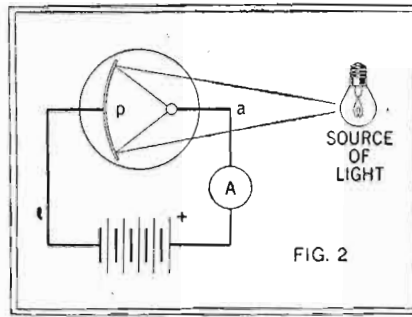

Diagrammatic representation of a photoelectric cell. The cathode, which emits electrons, is P; the other electrode, shown by the small circle, is the anode.

The force of attraction between the positive and negative charges holds the system together, just as the gravitational forces hold our solar system together. Thus the atoms of all substances are made up of the same ultimate units, protons and electrons. The differences between different kinds of matter are due to the different arrangements of these two kinds of building material.

This theory has met with great success in predicting the spectra produced by the different elements. All matter then is made up of atoms like these. Some kinds of matter, notably the metals, have the power of readily conducting a current of electricity. We believe that in material of this type, that is in *conductors*, there are a large number of free electrons; that is, electrons (in addition to the rotating electrons which are attached to each individual

atom) which are free to wander through the metal in accordance with the impressed electric forces. It is the actual motion of these electrons that constitutes an electric current. An electric current is nothing other than a flow of electrons.

To return to the photoelectric cell, it can be represented diagrammatically as shown in Fig. 2. Light falls upon the surface of the metal plate *p* and causes "photo electrons" to be emitted from it. The plate is connected to the negative terminal of a battery and the wire *a* is connected to the positive terminal. The positive charge on *a* draws the electrons across the space and so a current flows through the circuit. The electrode (*P*) which emits the electrons must always be connected to the negative battery terminal and is called the *cathode*. The positive electrode (corresponding in this to the plate of a vacuum tube) is called the *anode*.

This is purely a diagrammatical representation of a photoelectric cell. A more usual form is shown in the illustrations in this article. The inside of the glass bulb is silvered and contact is made with the silver surface by means of a platinum flush seal. This silver surface is coated with a thin layer of some material such as one of the *alkali* metals (lithium, sodium, potassium, rubidium, caesium) which are particularly photo-sensitive. This takes the place of the zinc plate of Hallwach's experiments. The other electrode is in the center. A circular opening serves for the admission of the light. Details of construction may vary, but the essentials remain the same.

ACTION OF THE CELL

The photoelectric cell, as we have said before, allows a current to flow through it when light falls upon it. Its particular value lies in the fact that the current passing through it is directly proportional to the quantity of light falling upon it. Doubling the light doubles the current, etc. For this reason the cell can easily be used for measuring light intensity or changes in intensity.

Of course, these photo-currents are small, so in order to avoid the necessity for using high-sensitivity instruments, amplification is resorted to. This is done by means of vacuum tubes as in radio work; but there is also a method of amplification within the photo cell itself which is of great value. This method makes use of the ionization of gases. For this purpose, after the cell has been exhausted a very low pressure of gas is introduced. This pressure ranges from 1/37,500th of an atmosphere in some of the larger types of cells to fifty times as much in the very smallest cells. The gas used must not react with the sensitive cell surface and it must also not "clean up" during the life of the tube. The gases which satisfy these requirements are the rare gases of the atmosphere and, of these, argon, neon and helium are the most frequently used.

The mechanism of the process is as follows. When light falls upon the sensitive surface of the cell, electrons are emitted and are drawn toward the anode by its positive potential. Some of these electrons, naturally, will chance to collide with gas molecules. As a matter of fact, at the lowest pressure mentioned there are forty-two thousand million million gas molecules in each cubic inch. Calculations show that an electron traveling through a gas at this pressure will make two collisions in each two-fifths of an inch

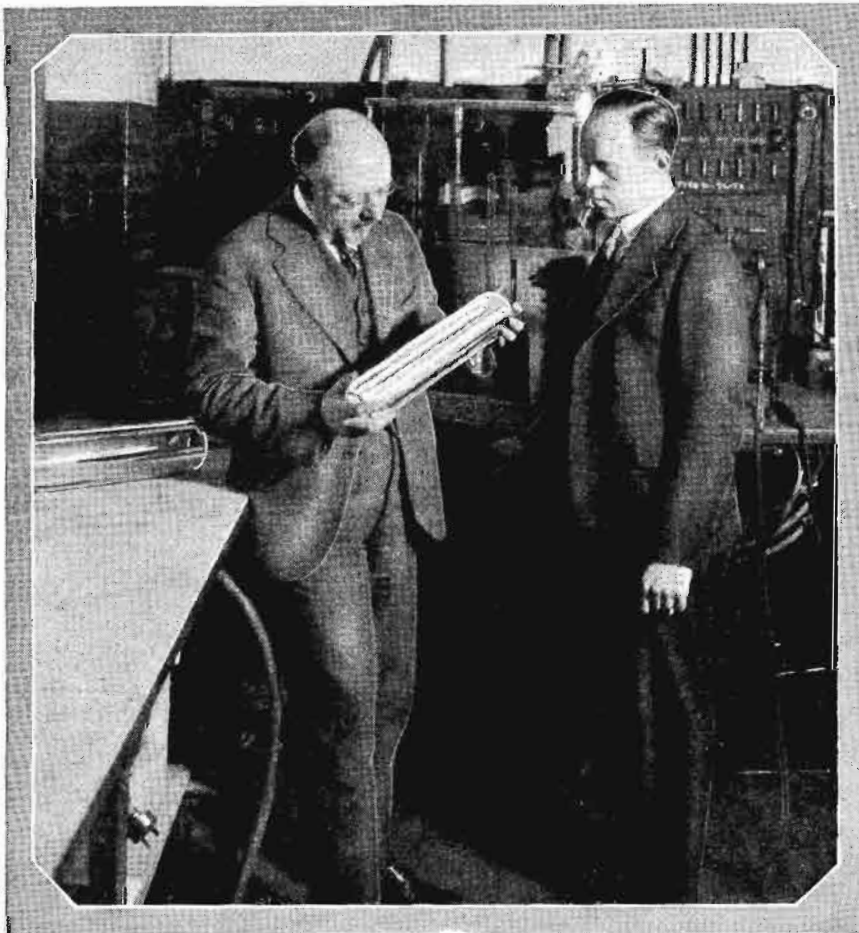

Dr. Herbert Ives (left), television expert of the Bell Telephone Laboratories, examining one of the large photoelectric cells used for television transmission. A close-up of this cell is shown at the top of the preceding page.

of its path on the average. It is the consequence of these collisions that is of interest. The collision may be of the same type as when two rubber balls come together; they will fly apart again, perhaps moving in different directions and at different speeds than before, but otherwise unchanged. Such a collision is of no use in producing amplification.

IONIZATION

On the other hand, a collision may take place with disastrous consequences to the gas molecule. When a collision of this kind takes place the photo electron actually knocks one of the electrons in the outermost orbit completely out of the gas molecule, or ionizes it. The result is that now, instead of the original electron and a neutral molecule we have two electrons moving over to the positive electrode; and the remainder of the gas molecule, which is now positively charged and is called a positive ion, moves toward the cathode. We have thus multiplied the original charge threefold. There is still the possibility of the two electrons making even more collisions before they reach their destination. This is no violation of the law of the "conservation of energy," because the energy required is drawn from the battery across the cell terminals.

The result of this process is that, for each electron which the action of the light liberates at the surface of the cathode, we may have several arriving at the anode. Since the flow of electrons constitutes the current, the gas may be said to amplify the photo current internally. The amount of amplification obtainable in this fashion depends on the nature of the gas, the intensity of the light source, the construction of the tube, and the voltage applied across the tube.

CHARACTERISTICS OF A CELL

The relation between the voltage applied to the tube and the current through it is called "the volt-ampere characteristic," curves of which can be obtained for different conditions of illumination by moving the light nearer to, or farther away from the cell.

At low voltages the current rises rapidly with the voltage. The current, of course, is simply a measure of the number of electrons which reach the anode. At first sight, this variable current would seem to be inconsistent with the fact that the number of electrons set free from the cathode depends only upon the intensity of the incident light. The apparent inconsistency is due to the fact that, at low voltages, all of the emitted electrons do not reach the anode. As the voltage is increased, a larger proportion of them reach their goal, and at one point the voltage is high enough to draw over all the emitted electrons. That is why further increases in voltage do not produce any further change in current and the curve continues as a straight horizontal line. The voltage which is necessary to draw over all the electrons is called the saturation voltage.

In order that the current may be a real measure of the light intensity, the voltage must always be above the saturation voltage. If the light intensity is now increased, a curve is obtained of the same shape as before, but the saturation value is higher to correspond to the new value of light intensity.

In the case of gas-filled cells the characteristics are radically different in form. As soon as a definite voltage, called the ioniza-



W. K. Zworykin, physicist of the Westinghouse Company, comparing a photoelectric cell of his design with a radio tube of the 199-type.

tion voltage, is exceeded some gas molecules become ionized. As the voltage is increased, still more ions are produced so that, instead of being flat, as in the case of the vacuum cell, the curve of current against voltage continues to rise. Eventually this curve becomes quite steep and the cell breaks into a glow.

HOW IT "SEES" COLORS

I have stated that the current through a photoelectric cell is directly proportional to

the intensity of the light falling upon it. However, this statement requires a little modification. It is true, provided the color of the light is not changed; but it is not true that equal intensities of blue and red light, for example, will produce the same response in the cell. In this respect the cell resembles the human eye, in that it is not equally sensitive to all colors. The maximum sensitivity of the average person's eyes occurs in the yellow-green portion of the spectrum. The maximum sensitivity for potassium cells occurs near the ultra-violet part of the spectrum.

This means that a potassium cell does not see colors the same way that we do; it is far more sensitive to blue and less sensitive to red light. Caesium photoelectric cells are the most red-sensitive of all, and consequently are the most desirable for any work involving color.

NOVEL USES

New applications of the photoelectric cell are arising every day. Two of the most spectacular ones are television and the talking movies. There are a number of systems of television, all of them fairly complicated; but the essential feature in all of them is the photoelectric cell. A beam of light travels across the object to be viewed and is then reflected back into a photoelectric cell. The amount of light falling upon the cell will depend upon the object; the white parts, let us say, sending a strong beam of light into the cell and the dark parts a weaker beam. These will produce, respectively, large and

(Continued on page 372)

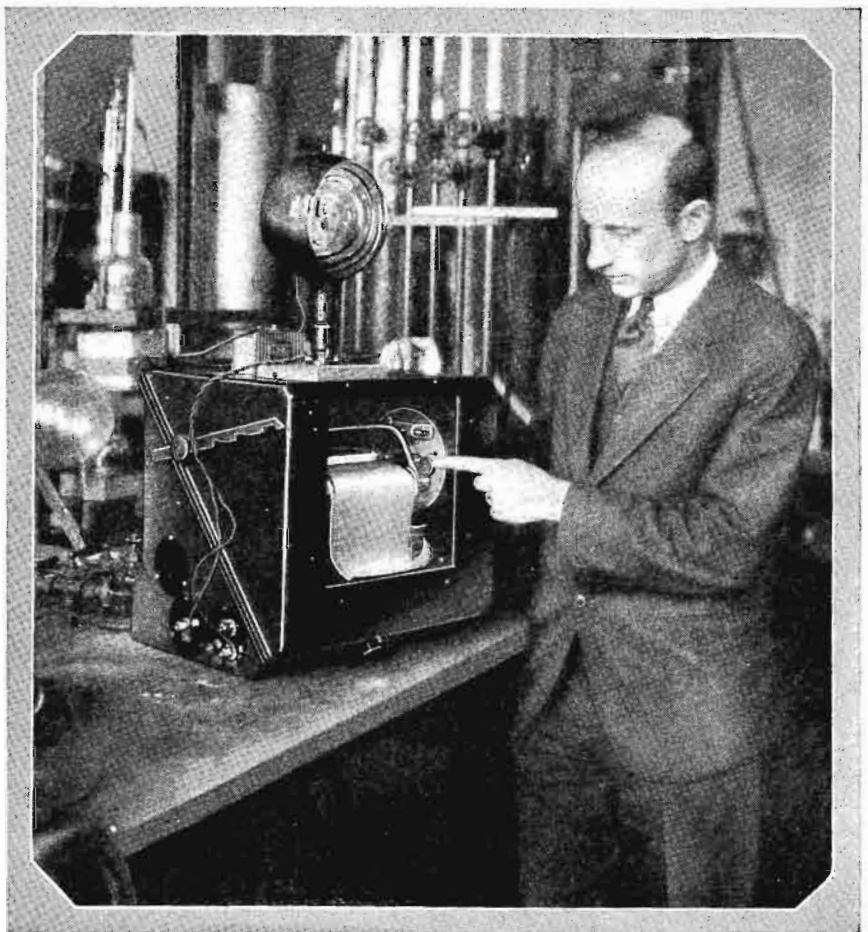

Dr. Koller is shown here with an automatic day/night recorder later installed on the ill-fated arctic dirigible "Italia." The photoelectric cell which operates the mechanism is on the top of the cabinet. (Photo courtesy of General Electric Co.)



More on Lightning

Editor, RADIO NEWS:

I note in your interesting editorial in the June issue that instances of lightning striking a radio aerial are very rare. I agree with you in this, but also say that everything happens once.

Two years ago, lightning struck the aerial of a broadcast fan directly across the street from my home. At the time I had an amateur's antenna, 45 feet high, erected in my yard not more than 200 feet from where the bolt struck. In this altitude, destructive bolts of lightning may leap to earth from clouds so small as to be hardly noticeable; this bolt came from such a cloud while the sun was shining. The bolt struck the aerial directly and melted the aerial wire and lead-in completely out of existence, down to the arrestor; and from the arrestor to earth the wire was not damaged. The arrestor had done its work, but died doing the job of grounding the bolt. The aerial was supported on two one-inch pipe poles at each end of the ridge of the house, and about five feet above the ridge. At the base of each pole a hole was torn through the roof, but otherwise no damage resulted.

My idea is that when a bolt of lightning is going to strike at a certain place, the small aerial will not dissipate the earth charge and "scare" the bolt to other places—or it would have struck my larger and higher aerial across the street. But I will also say that, had it not been for the aerial on that housetop, which received the shock, the house would have been seriously damaged. I have had aeriels erected all over my place of abode since the beginning of amateur days more than fifteen years ago; and this was my first sight of lightning actually striking one. I always feel safe under a properly-grounded aerial in any kind of electrical storm.

A picture of the house, taken at the time, shows a black streak down the side, where tiny bits of the melted lead-in wire were shot into the weather-boarding of the house. The radio set that was connected to it was only slightly damaged and was easily repaired. I thought this instance might be of interest to you.

NORMAN R. HOOD,

1022 So. Ash Street, Casper, Wyoming.

(Two other letters, not dissimilar in nature, have been received from our wide-spread army of readers on the subject; so it is evident that the number of cases of any damage by lightning to a house with a radio receiver in it have been few. In each case, the lightning arrestor functioned as it should. Lightning falls, seemingly, where it will, and plays queer pranks; but a properly-installed radio aerial reduces, rather than increases, the probability of a stroke, and conducts away practically the whole of its force if it does fall.—EDITOR.)

Conditions in Australia

Editor, RADIO NEWS:

In the rural centers in the eastern part of Australia, the average listener demands that his *five-tube* neodyne, T.R.F., etc., shall not only cover 250 miles in daylight, but do so at satisfactory speaker strength. This town is situated about 250 miles from 3LO, Melbourne (5 kilowatts) and 350 miles from 2FC, Sydney (also 5 kw.) and if you were foolhardy enough to offer the radio-buying public a five-tube outfit which would not give satisfactory volume from these stations without fuss, and miles above noise level, you would find it impossible to make a sale.

Quite a large number of American receivers are in use here and, if I may be permitted to name a high-grade one—the

THIS page belongs to the readers of RADIO NEWS. It is theirs for the purpose of discussing fairly and frankly the needs of broadcasting from the standpoint of the great public who listen in. The letters represent, not necessarily the editorial opinion, but that of the writers; who are, in the editorial belief, fairly typical of groups of opinion among the radio public. Make your letters concise and offer constructive criticism when you can; remembering always that there is something to be said for the other fellow's side.

Address The Editor, RADIO NEWS, 230 Fifth Avenue, New York City.

Stromberg-Carlson Model 501—I would like to give some idea of how it performs under our conditions. Also, if any owner of such a set in the United States would like to write me about its performance, I would be grateful. (I do not own one.) Here its performance is equal to almost any distance under 2,000 miles with a good antenna system. These sets have frequently picked up stations in Japan and the Philippines under favorable conditions. Other high-grade American sets show a similar performance.

Mr. Woodruff and Mr. Staves have something to say about supers. I cannot help thinking that some supers are not all they might be; especially Mr. Staves' set, which uses the same (Victoreen) I.F. system as my own. I hold that the air-core super, with high-grade A.F. systems, takes some beating for quality reproduction. With my set, which has high-mu tubes in the I.F., a regenerative first detector, power and super-power audio stages, and a two-foot loop, I have logged such American stations as WEAF, WJZ, WGY, KDKA and KGO in the winter months. The Japanese and Philippine stations can be logged at any time

of the year, with all Australian and New Zealand stations.

With regard to daylight work, I have repeatedly logged 4QG, Brisbane, at mid-day in summer time, at 950 miles airline, also on the loop, as well as all other eastern Australian stations above 1,500 watts. The New Zealand stations make their appearance at from 5:30 p. m. onwards, summer or winter. Oddly enough, a 500-watt New Zealand station has more punch here than its 5,000-watt brother.

In conclusion, I wish to thank you for an excellent journal. I wish it was published weekly. If I were American, I would say "you sure have got the goods." As an Australian, I say your publication is "Good, oh!"

E. MARTYN-JONES,
Box 93, Wagga Wagga,
New South Wales, Australia.

(Australia, comparable in size with the United States, and isolated by thousands of miles from any other country except New Zealand, has about thirty broadcast stations, several quite small. This perhaps has something to do with the excellent DX reception in the antipodal continent.—EDITOR.)

Five-Kilocycle Separation

Editor, RADIO NEWS:

Previous to December 1, 1927, we here in Los Angeles and vicinity were able to play clearly three stations within a ten-kilocycle band, namely: KSB, WLIB and KOMO. As nearly as we could tell, there were no more than ten kc. between KOMO and KSL for WLIB to get through, and we checked this point very thoroughly from here. WLIB was not coming through exactly in the center—they were about four kc. below KOMO and still we (and hundreds of others) played WLIB easily and clearly. This would indicate that it is possible to split up the allocated channels into channels of say six or seven kilocycles without interference from heterodyning carriers; possibly even five kc. if the stations were separated sufficiently geographically. Then, the listeners situated equal distances from all stations on the same channel would be able to play any of them; while those located near one of them would be no worse off than before. We have an example of that, with KFSD at San Diego, and WJR at Detroit, supposed to be on the same channel and yet actually separated sufficient for listeners here with a very selective receiver to separate these two stations enough to identify them, and with very little or no heterodyning.

Now that WLIB has been replaced with WIBO-WHT, we find that these stations have moved so close to KOMO that we cannot play either Chicago or Seattle clear enough to identify them, to say nothing of enjoying the program! When it comes to

(Continued on page 375)



A (RADIO) CRIME WAVE

VERNIERE: "Did you hear about the daring robbery down below last night?"

COYLE: "No, what was it?"

VERNIERE: "Why, the two Brackets held up the Panel!"

—Efty Kyprie.

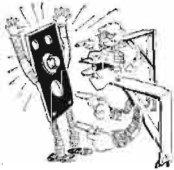

AN INGENIOUS WRINKLE

An oft-asked question is: "Is there any use for used "B" batteries?"

They are always handy when your neighbor wants to borrow one.—*Popular Radio Weekly (Australia).*

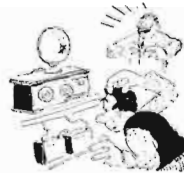

A TUNED-IN ALIBI

WIFE (hearing hubby fiddling with door-knob at 3 A.M.): "You old owl, what in the world are you doing down there at this time of night?"

HUBBY: "Pshh, (hic) I'm trying (hic) to tune out (hic) WOW for WOO."—*James Gibson.*



A HOOSIER BARGAINER

DEALER (to thrifty customer): "Now, these are the accessories of the set. These are the batteries, these are the tubes—"

CUSTOMER (a thoroughgoing shopper): "Are they the kind you can roll up when they get empty and squeeze it all out of them?"

(Dealer faints.)—*R. L. Wilson.*



A SCENE IN EVERY FAN'S LIFE

TALL MAN: "Congratulate me, Bill, the happiest event since I married!"

SHORT MAN: "Boy or girl?"

TALL MAN: "No. PCJJ on one tube!"—*Popular Wireless.*

THIS page is devoted to humor of purely radio interest; and our readers are invited to contribute pointed and snappy jokes—no long-winded compositions—of an original nature. For each one of this nature accepted and printed, \$1.00 will be paid. Each must deal with radio in some of its phases. Actual humorous occurrences, preferably in broadcasting, will be preferred. Address Broadcastastics, care RADIO NEWS, 230 Fifth Avenue, New York City.

A TRAGEDY OF 1929

FIRST OFFICE BOY: "How'd you lose your job, Jimmy?"

SECOND OFFICE BOY: "Aw, I told the boss I wanted the afternoon off to go to me grandmother's funeral and he saw me at the ball game over the television."—*Wm. G. Mortimer.*



A FUTURE M. I. R. E.

HARRY, aged four, turned up the regeneration on our radio until the usual results occurred.

After working on it a while, he said: "Daddy, you better oil the radio. It squeaks."

—*Mrs. Duce Nilsen.*



IT SOUNDED PROMISING

FATHER (to old-maid daughter): "We've tuned in almost every city of importance tonight, so where will we go next?"

DAUGHTER (enthusiastically): "Oh, dad, let's try to get the Isle of Man!"

—*E. H. Foley.*

OR A SHORT-WAVE FAN

"Is he an optimist?" "Is he? Why say, he took a course in foreign languages before he bought his one-tube radio set, so that he would be able to understand the foreign announcers!"



R. I. P.

D.: "Jones looks rather sad."

X.: "Yes, I heard him say he buried his Aunt Emma yesterday!"



AT THE STUDIO DOOR

STUDIO MANAGER: "What's the matter? You look all in."

BEDTIME STORY TELLER: "I had to hurry down without anything to eat; I slept in today."

STUDIO MANAGER: "Well, make it snappy, and get on the air with your bedtime story."

A SPORT FAN

MOTHER: "What's your brother Jimmy doing with the soldering iron and screw-driver?"

BOBBIE: "He's going to put another stage of ossified frequency in the radio set, so he can get the six-day race on 500 kilocycles."

—*George Lieberman.*

RADIO RHYMES

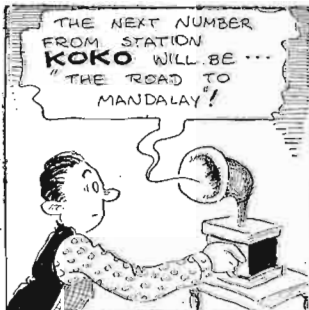

THE NEXT NUMBER FROM STATION KOKO WILL BE "THE ROAD TO MANDALAY!"

IT SEEMS WHEN'E'R I TUNE MY SET THE SAME REFRAIN I ALWAYS GET!

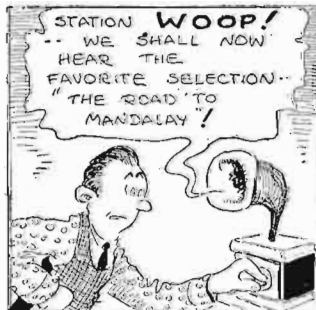

STATION WOOP! -- WE SHALL NOW HEAR THE FAVORITE SELECTION-- "THE ROAD TO MANDALAY!"

THIS VERY SONG, UPON MY WORD, AT LEAST A THOUSAND TIMES I'VE HEARD!

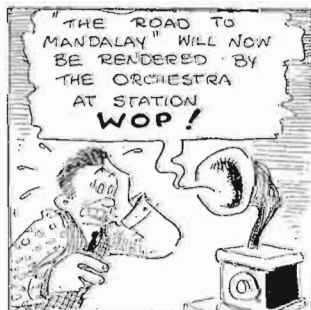

"THE ROAD TO MANDALAY" WILL NOW BE RENDERED BY THE ORCHESTRA AT STATION WOP!

YE GODS ON HIGH! -- IT'S HERE ONCE MORE! -- WELL, WOULDN'T THAT JUST GET YOU SORE?

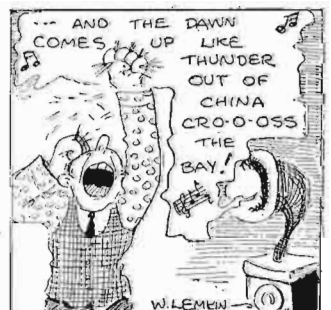

-- AND THE DAWN COMES UP LIKE THUNDER OUT OF CHINA CRO-O-SS THE BAY!

BY GOLLY! -- NOW AT LAST I SEE WHAT'S MEANT BY RADIO FREQUENCY!



What's New in Radio



A New Screen-Grid Receiver Using the Roberts Circuit

FROM the laboratory of a well-known Chicago manufacturer has come an interesting development of the popular Roberts four-tube circuit; namely, a screen-grid version comprising one stage of tuned radio-frequency amplification, a regenerative detector and two stages of audio-frequency amplification. The new set, which is available in complete kit form, possesses interesting new features. It was tested in the Radio News Laboratories, and yielded unusually good results for a simple four-tube affair. It is pictured and described on this page.

From the pictures presented herewith it may be seen that the receiver resembles in mechanical construction the modern factory-built receiver. All of the parts inside the set are mounted on a pierced steel chassis, which is housed within an attractive metal cabinet, finished in two-tone brown moiré, with gold high lighting. The tuning of the receiver is accomplished by means of two knob-operated drum controls, which are mounted on a bronze escutcheon plate together with the sensitivity knob, volume knob and battery switch. The chassis is mounted on a highly-polished mahogany base.

The all-metal design of this receiver not only provides the set with a finished commercial appearance, but also with other mechanical and electrical advantages. The all-metal cabinet, which is of one-piece construction, fits tightly over the chassis, thus providing a low-resistance shield for the set. When the cabinet is removed all the parts and wiring are readily available for adjustment or repair. The use of the pierced steel chassis makes it possible to locate a large part of the wiring under the base; this gives the appearance of neat workmanship.

The person who builds this set has the option of two different systems of wiring. The diagram which accompanies this article shows the circuit used when the set is intended for battery operation. However, the instructions supplied with the kit show the

for providing the desired values of grid bias, and by-pass condensers.

From the schematic diagram it may be seen that the R.F. circuit of the set is much the same as the standard, except for the fact that a screen-grid tube is used in the

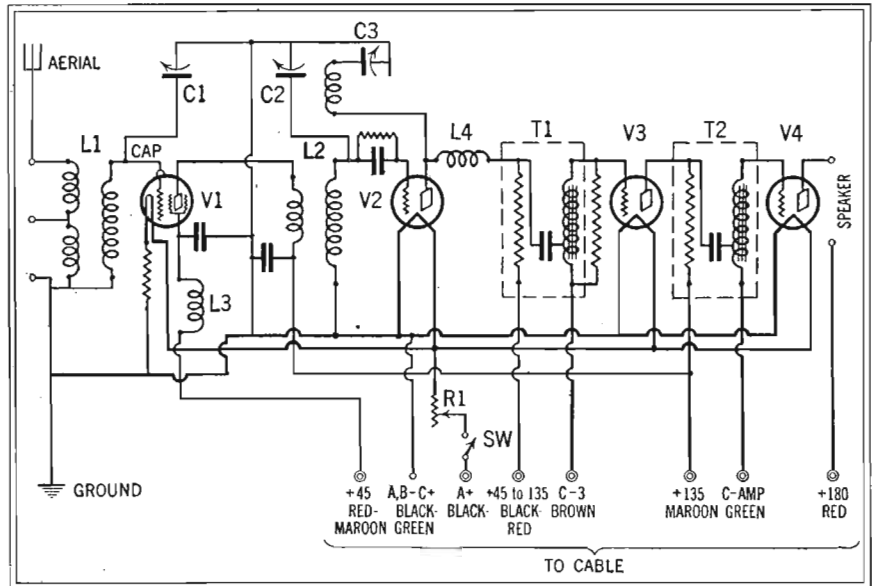

This diagram shows the complete circuit of the screen-grid Roberts receiver; the symbols employed to identify the various parts correspond to those used in the text and pictures. This diagram shows the set wired for D.C. operation, but an A.C. circuit using practically the same parts has been developed.

method for wiring the set when it is desired to use A.C. tubes and a "B" socket-power unit. The essential circuit of the set is the same in each case, but there are several slight changes in the parts and in the filament wiring. In the electric set the extra parts include fixed and variable resistors,

R.F. stage. This tube provides a voltage amplification between 20 and 35 throughout the entire broadcast waveband, thus making it possible for this receiver to equal in sensitivity the usual five- or six-tube receiver using standard tubes. Also, the amplification of the circuit is not very great when compared with the mu of the tube and, as a result, good selectivity is obtained.

The input circuit of the set employs a standard coupler, the secondary winding of which is tuned by a .00035-mf. double-spaced variable condenser of modified SLF-SLW design. The primary of the coupler is in two sections; half the winding is connected when great selectivity with a long aerial is desired, and the entire winding is employed with a short aerial. Volume is controlled in the receiver by means of a rheostat connected in series with the filament wire from the "A+" battery post; this system prevents the distortion which would be caused by overloading of the detector if the volume control were located in the A.F. circuit. A choke coil is also connected in the supply wire to the screen grid, and this overcomes coupling through the plate batteries.

An R.F. transformer with a fixed tickler winding is used to couple the plate circuit of the screen-grid tube with the grid circuit of the detector; the secondary winding of this

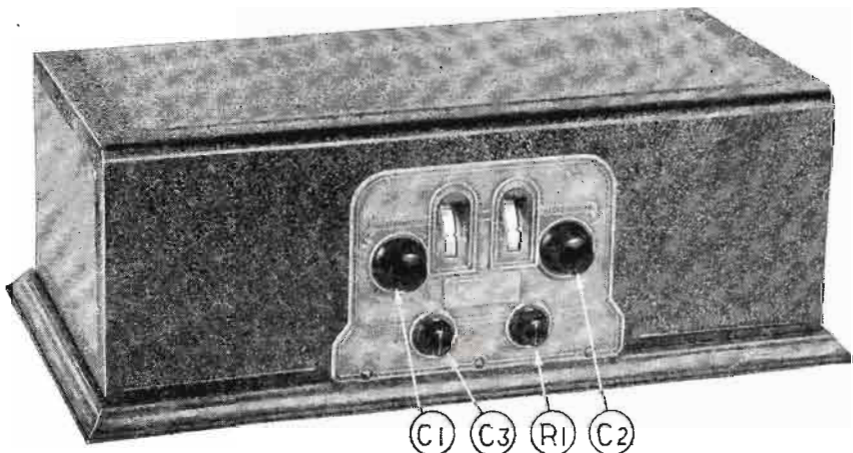

This picture is a front view of the new four-tube, screen-grid Roberts receiver. The tuning controls are mounted on a handsome bronze escutcheon plate, and the metal cabinet is supported on a highly-polished mahogany base.

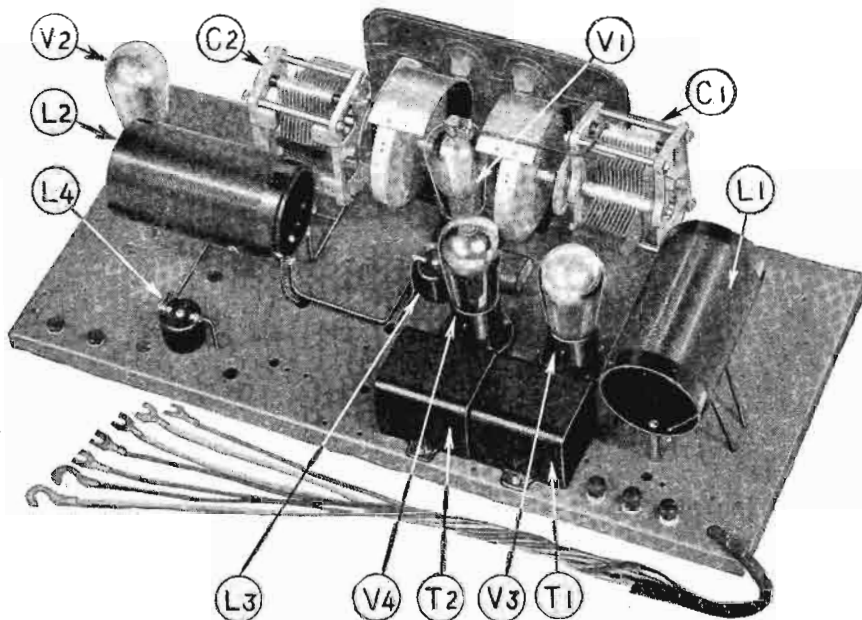

In this chassis view of the new Roberts receiver all parts are shown mounted in their proper positions. It will be noted that practically all wiring is located under the metal chassis.

transformer is tuned by a variable condenser similar to the one used in the R.F. stage. In this circuit regeneration is controlled by a .000075-mf. variable condenser (C3), connected so that the tickler coil is in series with the condenser between the plate of the detector tube and the "B—" or ground.

Probably the most unusual feature of the new receiver is the A.F. amplifier, which employs a new type of coupling device. The amplifier coupling units were designed especially to eliminate the distortion due to hysteresis; they do this by isolating the direct plate current and preventing it from flowing through the winding of the auto-transformer coils. A resistor and a condenser connected to each winding, as shown, accomplish this purpose.

Very uniform amplification is obtained over the entire band of audio frequencies. According to actual tests made in the manufacturer's laboratory, these units provide practically equal amplification at 65 and at 1,000 cycles. The amplifying units in the two stages are of different design; T1 has an effective transformation ratio of 4.3 to 1, and T2 has a ratio of 3.5 to 1. The overall audio amplification of the receiver, when using a 112-type tube in the position V3 and a 171-type tube in the output stage, is approximately 500; or more than twice the amplification obtained from a two-stage amplifier using the same tubes and 3 to 1 ratio A.F. transformers.

With the exception of the audio units and the metal chassis, cabinet and escutcheon plate, the parts employed in the construction of the receiver are of standard design. The R.F. transformers (L1 and L2) are of identical construction and are wound on threaded bakelite tubes 2½ inches in diameter. The secondary windings consist of 72 turns of No. 24 enameled wire spaced to a length of 2¼ inches. In addition, each coil has two other windings, consisting of 20 and 35 turns, the latter space-wound, of No. 34 D.C.C. wire. These coils are wound on 2¼-inch diameter tubes, which are placed just beneath the filament ends of the

secondaries; in L2 the 20-turn winding is used as the tickler.

The operation of the receiver is very simple. The two drum controls (C1 and C2) are the only tuning adjustments of the set. The only additional adjustments are the volume knob and the regeneration control. In operating the set it will be found that the two tuning dials have approximately the same settings for any given wavelength.

Manufacturer: Silver-Marshall, Inc., Chicago, Ill.

New Special Components for Set Construction

SIX radio parts intended for use in the season's new kit receivers have recently been introduced. They include: ballast shields for vacuum tubes, shield compartments, tube-base, type plug-in coils, intermediate-frequency transformers and balancing condensers.

The ballast shield, which is illustrated in the drawing, accomplishes two very important functions in a radio receiver. When installed it prevents electrostatic pick-up by the tube elements and consequently improves the selectivity and stability of the circuit. Secondly, it increases the mechanical inertia of the tube to such an extent that the elements will no longer respond to audio-frequency impulses and vibrations, and the familiar howling caused by such response is, therefore, prevented.

The ballast shields are available in two standard sizes: one for the screen-grid and other standard-size tubes, and the other for the small 199-type tubes. The large-size ballast shield is made in two sections and consists of a heavy die-cast base into which the bakelite base of the tube fits, and a formed copper shell which fits over the tube proper and screws onto the base. The tube is protected by felt pads, which are placed around it before the ballast shield is fastened in place. The small size ballast shield is a die-cast case finished in copper and lined with felt. It is designed to slip over the 199 type of tube, but it is not supplied with a base.

Seven different interchangeable inductors, of the type shown at A in the picture, have also been announced. This series of coils includes radio-frequency transformers for use in circuits functioning at broadcast frequencies; a transformer and a tuned impedance unit for use with screen-grid tubes in an intermediate-frequency amplifier operating at a frequency in the neighborhood of 115 kc.; and an oscillator coupler covering a waveband of 180 to 460 meters and suitable for use in superheterodyne receivers employing a 115-kc. intermediate-frequency amplifier. Also, in the near future, transformers will be available for the reception of short-wave signals.

The mechanical construction of the interchangeable inductors is shown clearly in a drawing which accompanies this article. The base of each coil form is equipped with four prongs which have been designed to fit into a standard UX-type tube socket. Also, each coil is provided with an easily removable primary coil, and various sizes of primaries are available separately, so that the type of primary winding best suited to the require-

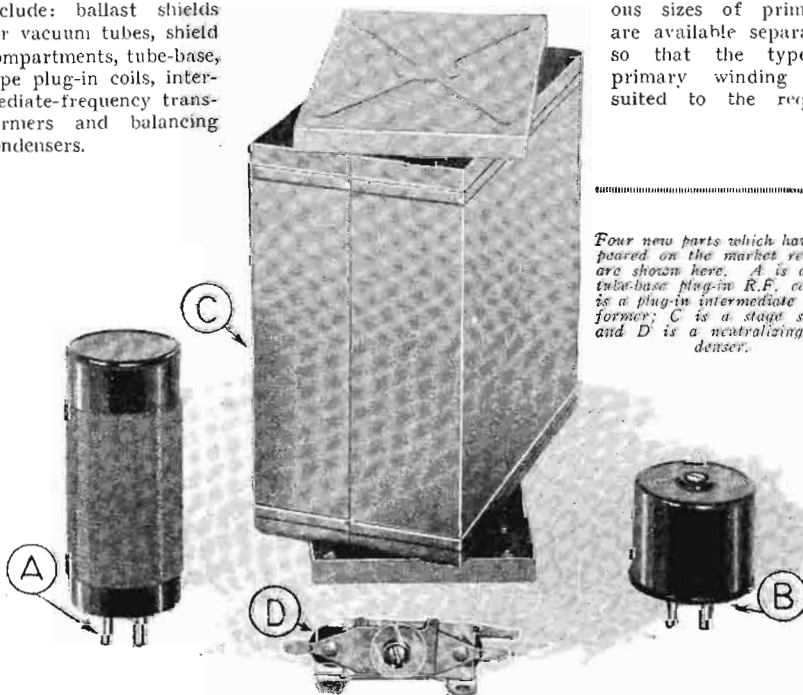

Four new parts which have appeared on the market recently are shown here. A is a new tube-base plug-in R.F. coil; B is a plug-in intermediate transformer; C is a stage shield; and D is a neutralizing condenser.

ments of the individual circuit can be installed. To remove the primary it is only necessary to lift out the top of the bakelite secondary coil form and to unscrew the two small terminal prongs in the base. These prongs project through the base of the secondary form and screw into inserts in the form on which the primary is wound.

Another type of plug-in inductor is shown at B in the picture. These units also use a standard UX-type socket as a terminal base and they are designed especially for use in the intermediate-frequency amplifier of a superheterodyne. Their most interesting feature is that they may be tuned to exactly the desired frequency by adjusting the small screw at the top of the case. This screw changes the capacity of a small condenser which is continuously variable over a limited range. Inductors of this model are available in two different types; the first is a transformer for use with standard tubes, and the second is an impedance unit for use with screen-grid tubes. Both types are tuned to a frequency of 115 kilocycles.

The shield compartment illustrated at C in the picture is of copper, sufficiently heavy to be rigid. It is 3 inches wide by 5½ inches deep by 5¼ inches high. The top and bottom of the shield are removable, so that mounting of the parts and wiring may be accomplished easily. The shield is intended primarily to accommodate two standard UX-type tube sockets (in one of which a tube is mounted and in the other a plug-in coil), and the necessary by-pass condensers, but it is not limited to this application. The base of the shield is drilled for the parts mentioned above, and a bracket is supplied for supporting the socket for the coil away from the bottom of the compartment.

A small balancing condenser is shown at D in the picture. This instrument has a capacity range of 5 to 70 mmf., and may be adjusted with a screw-driver by turning the small adjustment screw. It is ideal for balancing two or more condensers for one-control operation; when used for this purpose, one balancing condenser should be connected in shunt with each section of the multiple condensers. The balancing condenser is also useful for increasing the maximum capacity of a variable condenser.

Manufacturer: Gray and Danielson Mfg. Co. (Remler), San Francisco, Cal.

Below, combination ballast and shield for 199-type tube; Center, similar shield for the screen-grid 222-type and other standard tubes. Right, plug-in tube-base inductance coil with interchangeable primary.

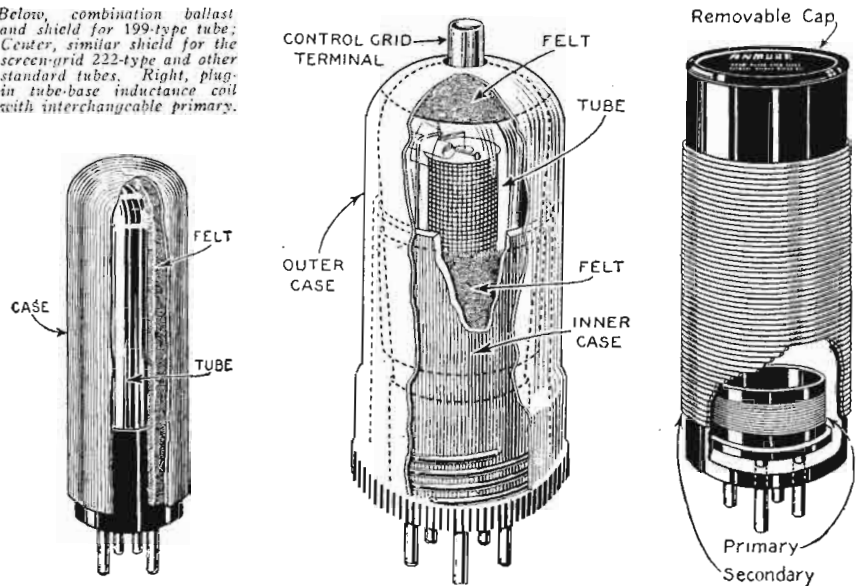

Efficiency of Television Increased by New Disc

A METAL television disc of improved design, with square scanning holes, has been placed on the market recently by a New England manufacturer. The disc is suitable either for transmission or reception and is of very rugged construction. It is twenty-four inches in diameter, has forty-eight holes, and is equipped with a large bushing for attaching the disc to a motor with a ½-inch shaft. When it is used for receiving the image is 1½ by 1½ inches.

In previous issues of this magazine the use of scanning discs for the transmission and reception of television has been described so frequently that little need be said in this article. However, the construction of the disc has never received much consideration. In most of the discs on the market the scanning holes are circular, as this construction is much simpler from the mechanical viewpoint. The square holes which are used in this disc are much more difficult to cut, but they are highly to be desired. A square hole will allow 27% more light to pass through the disc than a round hole of equal width, and this greatly improves results.

The additional light which is provided by square scanning holes in a television disc is very valuable at a transmitting station and is helpful also in receiving. The great-

est problem in transmitting television is supplying the photoelectric cell with sufficient light for its operation, and the solution to the problem is greatly simplified by the use of square holes in the disc.

Manufacturer: The National Company, Malden, Mass.

Special Television Motor Very Accurate

An alternating-current motor which has been designed especially for television

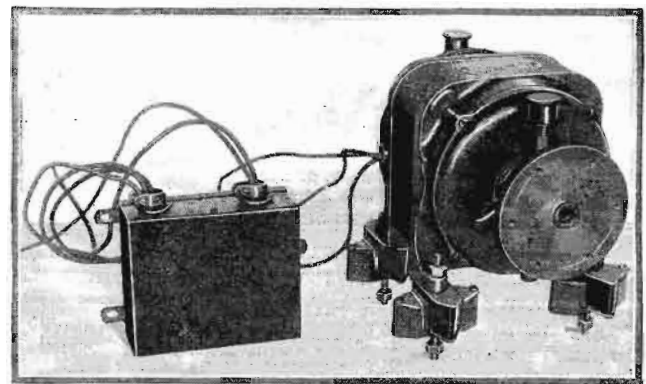

This television motor is very responsive to regulation, while steady in its speed. The large condenser in the case at the left acts on the motor's rotation like the airchamber of a pump.

reception and transmission is illustrated herewith. It is a condenser-type, single-phase, ball-bearing motor and the speed may be varied very easily with a series rheostat. It is quiet in operation and does not cause radio interference.

In a television receiver or transmitter the motor which turns the scanning disc is probably the most important piece of apparatus. At the receiving end the speed of the motor must be synchronized exactly with the speed of the motor at the transmitter, and if the motor is not easily adjustable or if it does not hold a constant speed, successful television reception is impossible. Also, the motor should not be of the usual commutator type, as the tiny

(Continued on page 382)

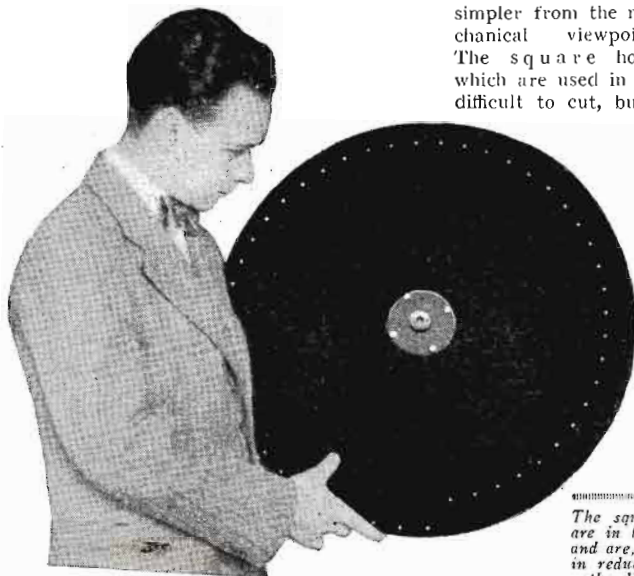

The square holes through this disc are in the center of the white dots and are, of course, too small to show in reduction. The workmanship on the disc is excellent throughout.

Interesting New European Screen-Grid Tubes

One Model Designed for A. F. Use Has Three Grids; the Auxiliary Electrode Neutralizes the Effect of Electron Emission from the Plate



By R. Raven-Hart
(PARIS, FRANCE)

ONE of the most interesting recent European productions is a screen-grid tube adapted to the last stage of audio-frequency amplification.

The internal arrangement will be seen from the picture, Fig. A, and the drawing, Fig. 1. It will be noted that there are three grids, an auxiliary grid being placed between the plate and the screen grid, and connected to the center of the filament. The function of this grid is to neutralize the effects of secondary emission from the plate, as will be explained later. The four prongs in the base connect to the control grid, the plate, and the filament; the screen grid being connected to the extra terminal mounted on the side of the base, and the third grid having no external connection whatever.

The constants given by the makers are as follows: filament voltage, 4 volts; filament current, 0.15 ampere; plate voltage, 50 to 150 volts, with the screen grid at the same voltage as the plate; amplification factor, 100; mutual conductance, 1.8 millimhos; and internal resistance, 55,500 ohms.

Fig. 2 shows the circuit arrangement, which is quite normal. It will be observed that this tube can be substituted for an ordinary (three-element tube) triode with very little change, by merely connecting the terminal on the base to plus "B."

Owing to the high internal resistance, the dynamic characteristic tends to approximate closely the static curves (as in the case of all screen-grid tubes); and thus a high dynamic amplification factor and mutual conductance are retained. Further, as the static curves are rectilinear between their working limits, the dynamic characteristic is substantially straight, even with an external impedance (loud speaker, etc.) very much lower than the internal resistance. In fact, instead of the condition aimed at with a normal three-element tube for a straight dynamic characteristic—that the external impedance shall be at least twice the internal resistance—the condition here is that the external resistance shall not exceed one-half the internal resistance. Otherwise, the plate may become negative with regard to the filament, the alternating voltage developed across the loud speaker exceeding that of the plate battery under these circumstances. Fortunately, this condition is exceedingly easy to realize.

FREQUENCY DISTORTION REDUCED

Thanks to the high internal resistance of the tube, frequency distortion (suppression of the high notes) is greatly reduced. With an ordinary tube, the impedance of the loud speaker is by far the greater proportion of the total impedance of the circuit, but here the internal resistance predominates. Hence the increase in the impedance of the loud speaker for the higher audio frequencies does not so greatly affect the total impedance, and there is less tendency for these notes to be weakened.

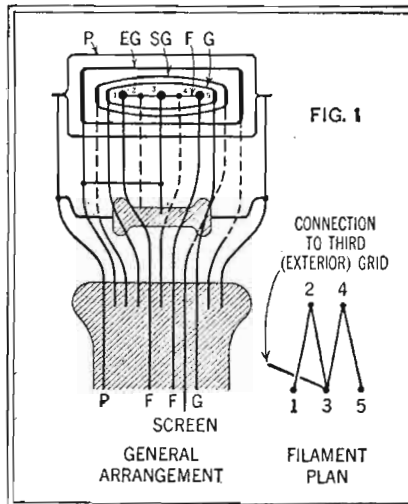

Above: Cross-section view of the five-electrode screen-grid tube. Note that the extra grid, EG, has no external terminal, being connected merely to the center of the filament.

Below: How the tube is connected in an A.F. circuit.

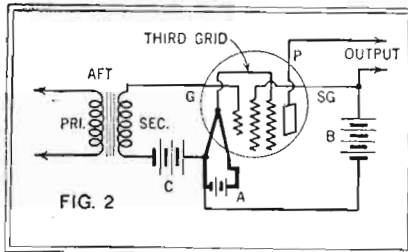

This is perhaps the first tube in which it has been necessary to take steps against the effects of secondary emission—the emission of electrons by the plate under the bombardment to which it is subjected by the filament. In a normal three-element tube such electrons are at once re-attracted by the plate and their charges reabsorbed. Here, however, the plate is frequently at a potential less than that of the screen grid (since an alternating voltage is developed across the loud speaker); and this, being alternately added to and subtracted from the voltage of the plate battery, makes the plate negative with regard to the screen every half oscillation. Under these circumstances the electrons of the secondary emission would be attracted to the screen and give rise to undesirable effects. The presence of the third grid, held at the potential of the center of the filament, causes them to be repelled towards the plate, and they are there reabsorbed during the next (positive) half oscillation.

A DIFFERENT R.F. TUBE

It may be added that the same makers produce a screen-grid tube for radio-frequency amplification, which is in general very similar to the American tube. However, it possesses the interesting variation that the terminal mounted on top of the tube is not that of the screen-grid, but that of the plate; the screen being connected to the pin in the base which would normally go to the plate. The internal arrangement can

(Continued on page 360)

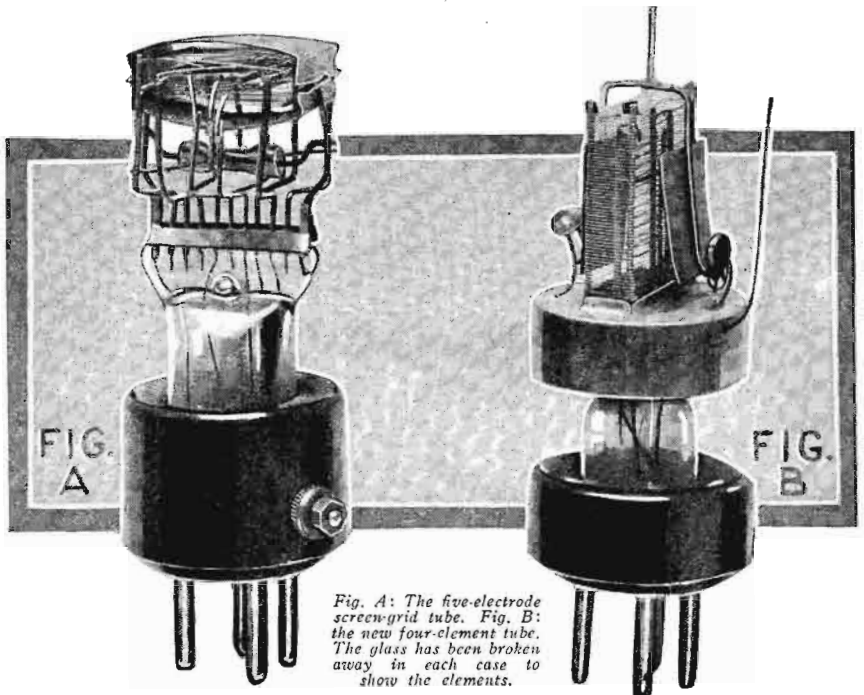

Fig. A: The five-electrode screen-grid tube. Fig. B: the new four-element tube. The glass has been broken away in each case to show the elements.



Under this heading, RADIO NEWS publishes each month descriptions of the latest developments in the extremely interesting field of television.

“Seeing” Music with a Television Receiver

TELEVISION has arrived, but as yet only a few scattered stations are transmitting television images. While preparing for regular television programs, however, the radio fan can perform some highly interesting experiments with a simple television apparatus that he can construct himself at little cost. This machine has all the parts of what is now generally considered the standard television receiver: namely, a scanning disc pierced by a spiral of holes, a motor to drive it, a neon glow tube, and a means of controlling the speed of the motor. By assembling it, the experimenter will obtain a good introduction to the theory and practice of television without having to spend a great deal of money on complex apparatus. After acquainting himself with some of the fundamental theoretical principles and practical operating difficulties, he will be better able to make and use a real television receiver when regular television service is available.

The parts composing the crude machine illustrated in these pages were picked up

at random in the Radio News Laboratories. An electric fan, which was about to be packed away, was instead dusted off and the blades and wire guard removed from it. As the fan was of the “oscillating” type, the worm mechanism which makes it swing back and forth was unhooked, so that the motor would remain stationary while in operation. (These operations did not ruin the fan, as the blades, guard and worm mechanism can be reattached in a few minutes.) It was decided to use a fan instead of a special television motor because fans are very widely used, and because the summer will be well over by the time the constructor builds this machine. Few people would care to spend \$25 or \$30 for a special motor just for an experiment, but they can easily make use of an idle electric fan.

The general appearance of the complete machine, as assembled in the Radio News laboratories in about two hours, is shown in the pictures on this and the facing page, and in uncompleted form on the front cover. It was built, not for the purpose of receiving television images, but merely

to show how ordinary voice and music “looks” in a television receiver. The geometric patterns and formations built up by the apparatus are extremely interesting to behold. More will be said about the operation later.

A CHEAP, USABLE DISC

After taking the fan apart, lay it aside for a while and make the scanning disc. All the discs which are now being sold commercially for television purposes are made of aluminum and are accurately drilled with round or square holes, not more than one sixteenth of an inch across. For this home-made contraption, an ordinary flat piece of cardboard is perfectly satisfactory. It should be not less than a sixteenth of an inch thick, and cut into a disc 12 inches in diameter.

With the aid of a pencil, a ruler and a compass (which you can borrow from your son's or little brother's school bag), now mark off 24 radii (lines running from the center of the disc out to the edge). These should be 15 degrees apart. As a circle has 360 degrees, the lines will radiate outward evenly. If you have forgotten how to subdivide angles with a compass, simply draw one diameter first through the center of the disc. Then draw another one exactly at right angles to it. These gives you four lines. Now spot the middle of each of the four sections as closely as you can, and draw four more lines from the center. If you now subdivide each of the resulting sections into three equal parts, you will have the twenty-four lines.

Take the ruler and measure a distance of $5\frac{1}{4}$ inches along the vertical center line. Make a mark at this point. Proceeding on the next line to the left, measure a distance of $5\frac{3}{16}$ inches. Proceed along, measuring off the distances as indicated in Fig. 1 on page 315; you will have a total of 24 points. Through each one, drill a hole slightly less than $\frac{1}{8}$ -inch in diameter; then, with a piece of stiff wire or a narrow strip of brass, ream out the holes so that they will be square in shape. Their edges are bound to be a little fuzzy, but do not worry about this.

For those who want to save themselves the trouble of marking out the individual lines, Radio News has prepared full-size blueprints which can be used as drilling templates. To use one of these blueprints, you simply lay it over the piece of cardboard and punch through the center points marked on it. (These templates are free; simply write to Radio News, 230 Fifth Avenue, New York, N. Y., and ask for the Television Disc Blueprint.)

If you haven't a piece of cardboard of the right size at home, go to the nearest stationery or draftsmen's supplies store and ask for a piece of heavy bristol board. This will cost only a few cents.



Fig. A. The experimental television receiver in the Radio News Laboratories. The only adjustment is the knob regulating the motor's speed. The patterns created by the music are observed through the square hole cut in the cloth, opposite the neon lamp.

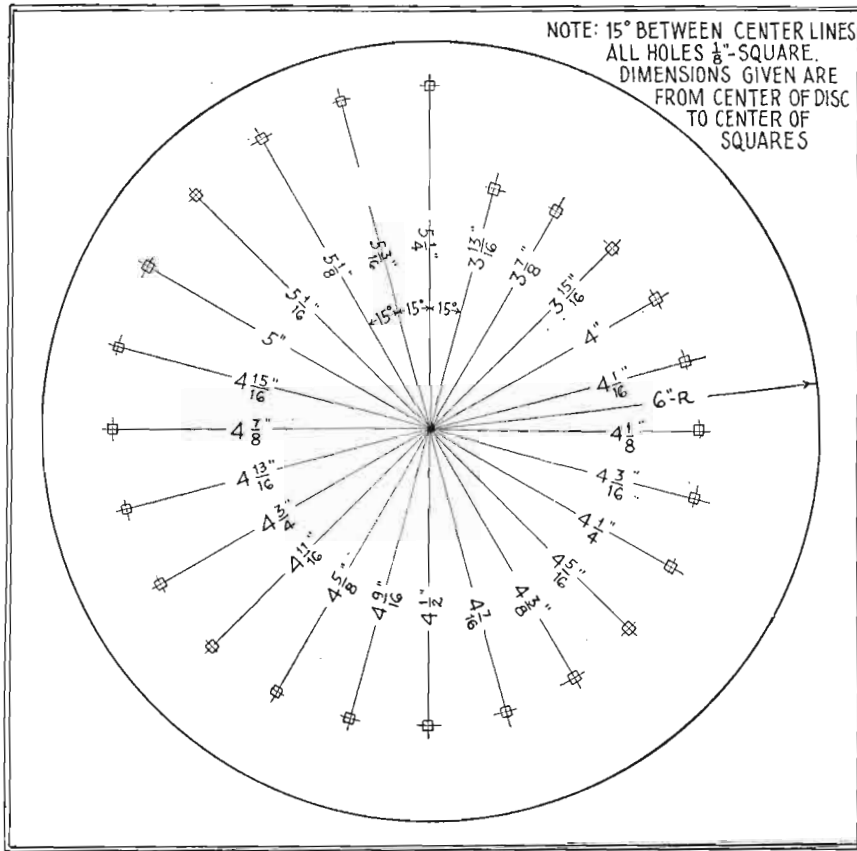

reproduces the changes as variations of light. When a regular television receiver is being operated with television impulses, a picture is built up on the plates of the tube with the aid of the scanning disc.

On the other hand, if voice or music impulses are led to the tube while the disc is rotating, endless varieties of patterns will be observed. After watching them for a while you will be able to distinguish a low note from a high one by merely watching the picture it makes; and you will be able to tell the difference between voice and music.

The neon tube is suspended just behind the scanning disc. It may be either fastened to the underside of the bread board that holds the radio receiver as shown in the pictures (Figs. B and C) or supported on an arm such as that shown on the front cover. In the laboratory machine, four corner pieces (old broom sticks) were used to allow a cloth cover to be tacked around the fan. A hole was cut in the front of the cloth, so that the upper section of the disc between the farthestmost and innermost holes could be observed. The neon tube should be so placed that the hole which is $5\frac{1}{4}$ inches from the center of the disc passes just across the top of the plate, and the hole which is $3\frac{13}{16}$ inches from the center just across the bottom edge.

THE CIRCUIT

A double-impedance unit, such as are used in audio amplifiers, is mounted anywhere along the breadboard on which the motor rests. A 60-ohm rheostat for controlling the speed of the motor is mounted on the front edge, so that it can be adjusted easily.

(Continued on page 385)

After drilling the scanning disc, the next problem is to mount it to the shaft of the fan motor. Obtain from a hardware store a pulley that will fit the shaft of your particular motor. This will have a set screw which allows it to be tightened against the shaft. To fasten the cardboard disc to the face of the pulley, first drill and tap the latter for four 8-32 screws, then clamp the disc between two 5-cent phonograph records and pass the screws through into the pulley, as shown in Fig. 2 (page 365). This was the arrangement used in the original model of the machine; but any other that suggests itself may be employed. The important thing is to make the disc run as smoothly and as evenly as possible. After mounting it, give it a coat of black paint. Liquid shoe polish will serve just as well; the idea is merely to darken the cardboard.

THE FLASH LAMP

The main item of expense involved in this "television" receiver is the neon glow tube. This costs about \$12, but is a good investment because you will be able to use it later in any real television instrument you build. This tube is about six inches long and two and a half inches in diameter, and is fitted with a standard UX-type base, which fits in a standard tube socket. It contains two flat metal plates, placed about a sixteenth of an inch apart and parallel to each other. When an electric current of the proper value is passed through it, the entire surface of one of the plates lights up with a pinkish-red glow, characteristic of the gas neon. The eye-catching red signs now being used so extensively for advertising purposes contain this same gas.

The neon glow tube responds to changes in electrical current just as a loud speaker does but, instead of producing sound, it

Fig. 1. Details of the scanning disc used in the set-up. The holes overlap; but very interesting images are obtained.

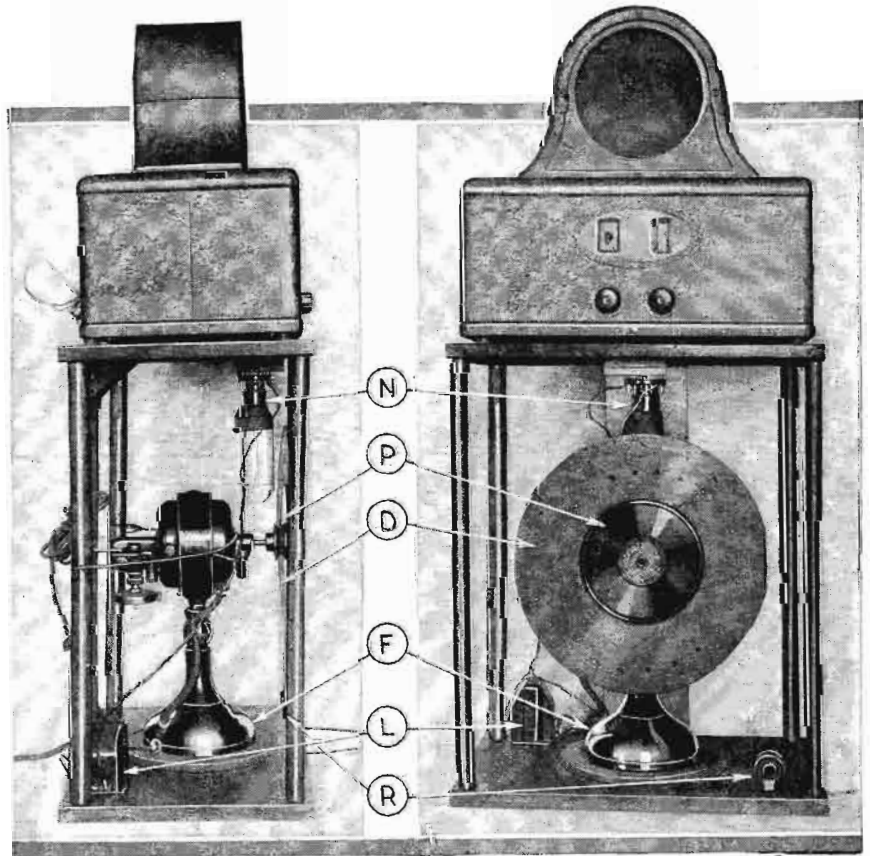

Figs. B and C. The apparatus with the cloth cover removed; N, neon lamp; D, scanning disc; P, phonograph records used for clamp (see Fig. 2); F, fan base; R, motor rheostat; L, double-impedance unit (see Fig. 3).

Radio-Picture Equipment for Police

German System Transmits Illustrated Circulars to All Large Cities Simultaneously Within Three Minutes

By Dr. F. Noack
(BERLIN, GERMANY)

THE pioneer of radio-picture transmission, Professor Korn, who has devoted over twenty years to the task, has lately developed a new system, with the cooperation of the Prussian ministry of the interior and of the police. The equipment designed for use in the transmission of pictures and facsimile messages between police headquarters in various cities, and illustrated here, has been constructed by the C. Lorenz Company of Berlin.

The transmitting apparatus employed is somewhat similar to that of the Telefunken-Karolus system, now in extensive use in Germany and Austria (see Radio News for November, 1926, page 466), but there are numerous differences in the receivers. In the latter, the light impulses are converted into electrical variations by the ring-shaped Karolus photoelectric cell, which is very costly. In the Lorenz-Korn system a small tube-shaped photoelectric cell of the ordinary type is used; with 120 volts across it, its response to light is in the order of .01-microampere to each lux (slightly less than a foot-candle.)

NOT TOO SENSITIVE

The Korn system transmits impulses only as black or white, being therefore much less sensitive to interference, static and other disturbances than the Karolus method, which is designed to transmit and reproduce half-tone shadings.

The Korn receiver is of the usual vacuum-tube type; the detected signals, which correspond to the impulses impressed by the image on the photoelectric cell at the transmitter, are passed after amplification to the windings of a highly-sensitive mirror galvanometer (shown as 1 in Fig. B and 20 in Fig. 2). This reflects the beam, cast upon it from a suitable source of light, through a small slit in the covering of the receiving cylinder, which is covered with sensitized paper. The thickness of the fila-

ment suspending the galvanometer mirror, and the width of the slit are so proportioned that a very slight deviation of the mirror will not cut off the light beam; but that resulting from a strong signal will do so. Thus slight disturbances, atmospheric, etc., are not sufficient to produce a visible spot on the picture. This freedom from interference, essential for the important purposes of the police and

effect this in systems operating at high speed. Professor Korn's apparatus functions at a moderate speed; although in early experiments it was operated at a very high one, transmitting about 10,000 dots per second (a practical television speed), this was found to require the use of a galvanometer which was too sensitive to electrical interference. The transmitter now in actual use sends at the rate of 2,400

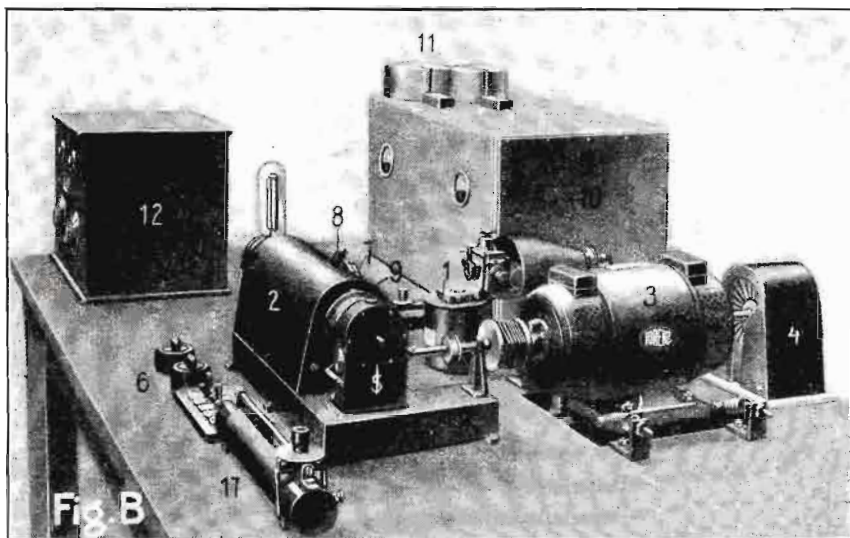

The radio-picture receiver: 1, galvanometer; 2, casing of picture cylinder; 3, motor; 4, synchronizing discs; 6, switches; 8, hole for adjustment; 11, synchronizing-note filter; 17, motor rheostat. Other parts are shown in the diagrams opposite, Figs. 2 and 3.

other government agencies, is obtained only by abandoning the attempt to transmit intermediate depths of shading.

SYNCHRONIZING MODULATION

One of the requisites of successful picture transmission is the synchronization of the revolving mechanism at the transmitter and at the receivers; it is extremely difficult to

dots, each 1/100-inch square, per second; and reception at this speed is found to be practically free from interference.

In order to synchronize the transmitter and receivers, the following ingenious method is used; a commutator-disc (10 in Fig. 1) is mounted on the shaft of the driving motor of the transmitter. By this means an 1,100-cycle alternation is impressed on the grid circuit of the amplifier, and modulates the signals which are broadcast. At the receiver, this doubly-modulated signal is detected and amplified, as we have said; the 1,100-cycle modulating note is passed through a special amplifier and filter, and passed to the synchronizing motor which drives the mechanism. At the same time, an 1,100-cycle current is carried to a glow lamp which illuminates a disc mounted on the motor's driving shaft. By means of the "stroboscopic" effect (explained in Radio News for August, 1927) it is easily possible to determine when the synchronizing impulses have brought the motor at the receiver into step with that at the transmitter. A steady illumination will then be seen on looking at the disc. Any needed correction is made by simply adjusting the resistor regulating the motor's speed. The synchronizing signal, however, is not of sufficient strength to disturb the comparatively insensitive galvanometer and affect the picture.

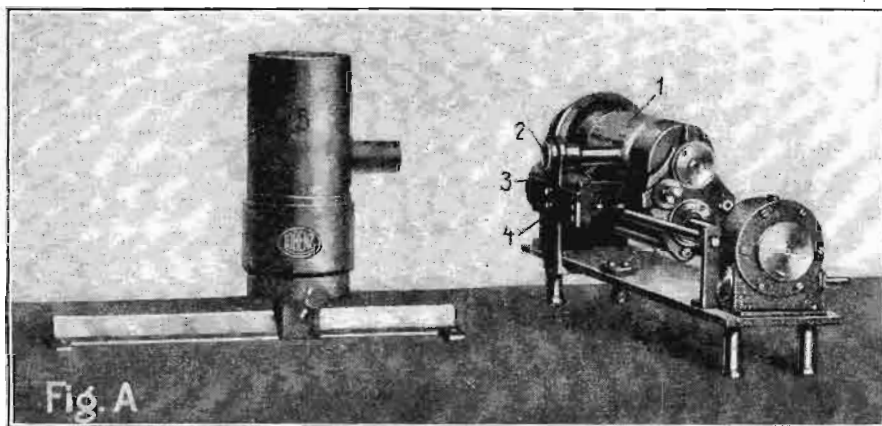

Transmitter of the Lorenz-Korn radio-picture system: 1, picture cylinder in its mounting; 3, photoelectric cell, and 4, its lens; 5, source of light and 2, its condensing lens. Other apparatus is indicated in Fig. 1.



second necessitates only two and a half minutes to receive a picture about 5 x 7 inches. The adaptability of radio-picture service to many purposes is apparent; such as the transmission of news events, facsimiles of public and commercial documents, manuscript, etc.

The appearance of the transmitter is shown in Fig. A, and its schematic circuit is diagrammed in Fig. 1. The receiver is pictured in Fig. B; its schematic circuit is shown as Fig. 2, and a pictorial diagram is Fig. 3. The parts can be identified readily from the captions of these illustrations.

While this system differs only in details from other radio-picture methods, it marks a distant advance in the practical application of the system to broadcast, rather than point-to-point transmission.

Fig. C. Typical German police broadcast of the picture and fingerprints of a man who is wanted. Though in black-and-white, the picture received has a photographic effect.

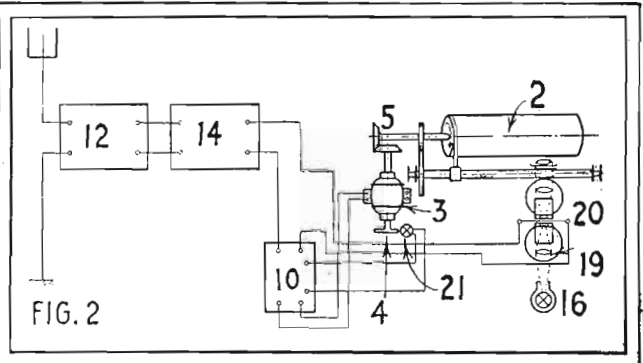
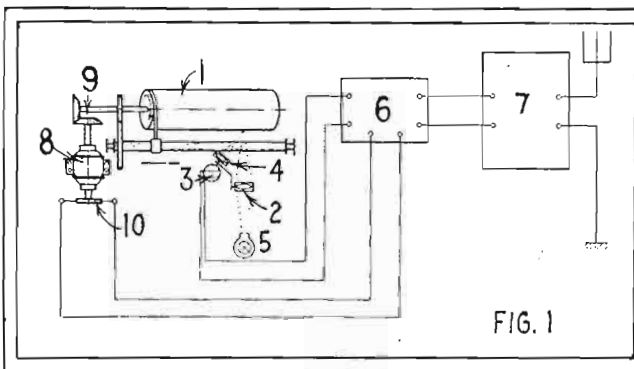

The right moment for the commencement of rotation of the picture-cylinder is signalled by an impulse from the transmitter, which is received by a polarized relay at the transmitter. This closes a circuit which magnetically operates a coupling clutch, connecting the worm-gear of the motor to the shaft of the cylinder.

ADVANTAGES OF THE SYSTEM

The nature of the modulation is so even that the transmitted wave is very sharp; the carrier-wave, at this low speed of transmission, is modulated by only 1,200 cycles and the side bands are very narrow, so that there is no jamming of the channels of communication.

Transmission at the rate of 2,400 dots a

Fig. 1, the transmitter: 6, amplifier; 7, transmitter; 8, driving motor, and 9, gearing; 10, synchronizing disc. Figs. 2 and 3, receiver: 5, gear; 7, slot for galvanometer light-beam; 9, magnetic coupler; 10, synchronizing-note amplifier; 12, radio receiver; 14, relay; 15, case for film; 16, 19, 20, lamp, lens and galvanometer; 21, "stroboscopic" synchronizing lamp. See Figs. A and B.

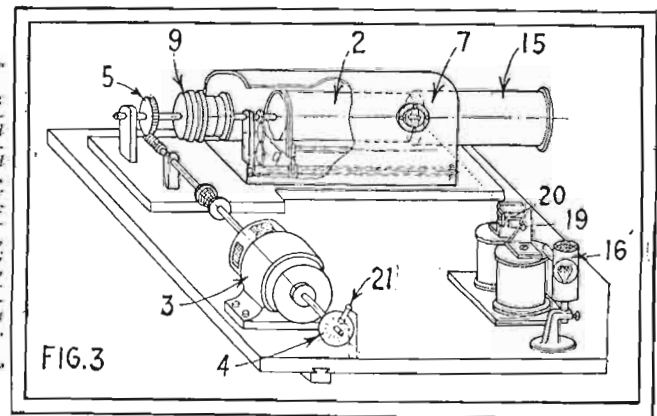

The "Fultograph" Radio Picture-Broadcast System

BROADCASTS of pictures have been demonstrated, and will be, in increasing numbers, it is believed, a feature of European programs. The system of Capt. Otho Fulton has been designed for the purpose of home reception with a minimum of apparatus. The photoelectric cell is not employed; the receiver, in particular, looks back to the principle of Morse's original telegraph apparatus — discoloration of chemically-prepared paper by current flow.

To prepare a picture for broadcasting, it is transferred photographically to a thin sheet of copper, by a process somewhat similar to that of making halftone "cuts" for printing. This copper plate has been covered with a film of glue treated with bi-

chromate of potash; when a negative print is taken upon it, the glue exposed to light becomes insoluble. That representing the white areas (black in a negative) is dissolved. The black surfaces in the original picture appear as bare metal.

When the prepared foil is wrapped around a metal cylinder and a metal contact caused to move over it, each spot of bare metal passes an electric impulse which is amplified and broadcast in the usual manner. When it is received and detected (a two-tube amplifier is said to be sufficient) each flow of signal current passes through a contact into a sheet of paper which has been wrapped around a similar cylinder, and causes a brown discoloration varying in

depth of color with the value of the current. The transmitted, and consequently the received picture, is divided by a screen into dots like a halftone illustration.

The Fulton apparatus is driven by clock-work instead of motors; for purposes of synchronization, a metallic conducting strip is left on the transmitting cylinder. Whenever the contact reaches this, an impulse is sent which operates a magnetic relay at the receiver and lifts the printing contact, thus synchronizing the two cylinders at each revolution.

It requires some time—about 45 minutes—to make up the copper foil picture for transmission. A picture 3½ x 4½ inches is sent in 3½ minutes, says *Amateur Wireless*.

The Radio Bean Sorter—A Novelty

Unique Machine Which Automatically Separates Colored Beans
Uses Photoelectric Cell and Radio Amplifier; Can Be Built Easily

By Herbert W. Augustadt*

THE applications of the photoelectric cell to many operations, industrial and commercial, are scarcely limited. This cell can not only take the place of the human eye in many ways, but in others it can perform functions that the human eye cannot. Because of its newness, the photoelectric cell should be very interesting to the experimenter; new applications for experimental purposes suggest themselves all the time.

The machine with which this article is concerned was built for the purpose of separating colored beans of all colors from white ones. As an automatic seeming intelligence, it not only makes a striking exhibit, but also a very interesting machine for the average experimenter to work up.

CONSTRUCTION

The construction of the machine is simple, for anyone who has done the least bit of work in radio. It is well known that a photoelectric cell passes more current when light falls on it, than when in the dark. This principle is used in this machine by causing the beans to pass under a light that is reflected on a photoelectric cell. The colored beans reflect less light than the white ones; hence, the current through the cell changes. This change in current is amplified and caused to actuate a relay which removes the colored bean from the belt.

Since direct current is used in this machine, the amplifier must be built to amplify direct current. The frequency of the variations is so low that it would be impossible to use an amplifier of any other kind than a resistance-coupled one. The diagram of such an amplifier hook-up is shown in Fig. 1.

The variations in current are very small; for the passing of a single bean under the focus of the cell does not cause a great variation in the light and, hence a large amount of amplification is necessary. To

accomplish this purpose, one should use, for the first three stages, "high mu" tubes, whose distinguishing feature is their high amplification factor. The last tube should pass a large amount of current to actuate the relay; and hence a power tube should be used.

The bias for the tubes may be obtained from old "B" battery cells, that were long ago unfit to supply plate current, but still have voltage. A high bias is necessary to keep the plate current low in the first tubes. The potentiometer around the bias battery will make it easy to adjust this voltage for different conditions, and hence is suggested. The bias can be obtained direct from the battery without the potentiometers; but in that case the adjustments are hard to make without a battery that has taps every 1½ volts.

The first relay, A, in Fig. 1, is the more sensitive of the two. The experimenter can use telegraph relays, if he has nothing else; they were tried and worked very satisfactorily. The relay is set to act on the least current possible and still have positive action. Its contacts close on the second relay, in series with a 1½-volt cell. These contacts then close on the buzzer, which is used as the "kicker" to throw the colored beans off the belt. It was found better to use two relays, to prevent burning of contacts and inductive kicks passing through the machine.

MECHANICAL DESIGN

The construction of the machine proper is shown in Fig. 2. The belt was made of white canvas about an inch wide, and passed around two spools. A small motor, M, was used as the driver. The hopper, H, fed the beans to the belt and was built to drop only one bean at a time on the belt.

The hopper was constructed from an old funnel, the bottom of which was removed to make an opening about the size of a solder box. Then an ordinary solder box

was punched, making a hole the size of the beans it was desired to sort; a bakelite disc, with the same size of hole, was fitted into the solder box. The disc was attached to a crank, which brought the hole in the solder box and the hole in the disc in line with each other every revolution, allowing a bean to pass through. A small arm was fastened to the crank in the bottom of the hopper, to scrape and stir the beans and make them fall into the hole. The beans were then led to the belt by means of a spout, and guided into the middle of the belt.

The kicker, which threw the colored beans from the belt, is the contrivance shown at B, in Fig. 2, and is made from an ordinary buzzer; soldering a brass strip to the armature of the buzzer and increasing the length of travel by bending back the armature. The kicker was controlled by relay C.

Since the maximum variation of light is desired at the time of the passage of the dark bean under the focus of the photoelectric cell, a lamp, L (Fig. 2), was used to obtain a bright spot of light on the belt over which the beans must travel. The lamp used was obtained from an old automobile and adjusted to have its focus about a foot from the lens. Inside the lens a cardboard was then inserted, with only a small hole in its center. Over this hole, and on the outside of the lens, a watchmaker's eyepiece was placed. By this means, it was possible to obtain a bright spot of light not much larger than the beans to be sorted.

The photoelectric cell was then placed so that it would face the small spot of light, and fitted with a hood that allowed light to come in only from a small opening directed on the spot of light. Unless a hood of this kind is used, variations in the light of the room, or shadows from observers, will affect the working of the cell and may cause the relays to chatter.

The time-lag, of the effect of the varia-

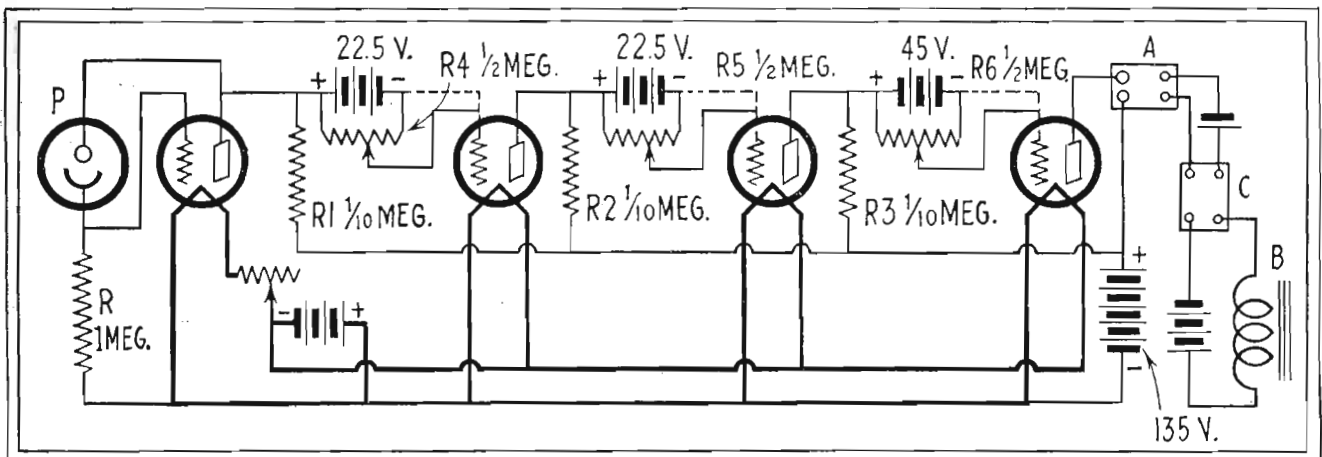

Fig. 1. The electrical circuit of the sorter. P, photoelectric cell; A and C, relays; B, "Kicker," made from buzzer. The first three tubes should be of the high "mu" type, like the 240 and 340 tubes; the last

a 171A or a 210. Old "B" batteries may be used to bias the grids of the amplifiers. If the parts of the amplifiers are shielded, the circuits will be more stable than if left unshielded.

tion of the light, on the cell and the action of the relays is very small, in fact it is almost zero; and so the light-spot should be focused directly ahead of the arm that kicks off the colored beans. It will be found easier to focus the light and cell, if they are mounted so that they can be moved in two planes.

ADJUSTMENT

The values of bias given are approximate, and so it is desirable to adjust the machine to the best working conditions. This is accomplished in the following manner:

All the tubes are removed except the first and second. A milliammeter is then inserted in the plate circuit of the second tube, and on this tube is placed a bias that will keep the normal value of the plate current under 4 milliamperes. After this is accomplished, a colored bean is placed on the belt and run back and forth through the light-spot. The grid bias is adjusted until the variation in plate current is the greatest.

If no variation is recorded, it is more than likely that the cell is not directed toward the light spot. This can be determined by shutting off all of the light. Such action should produce a difference in plate current. If it does not, the cell should be moved around until the plate current does vary and should be fixed in the spot where the plate current is at minimum. The plate current will drop to a minimum at the time that the maximum light is falling on the cell; because the two tubes in the amplifier are connected so that plate current through the first causes an increase in negative bias on the second. The opposite effect takes place when no light falls on the photoelectric cell.

The adjustments for the third tube are made in a similar manner. A plate-current variation of 5 milliamperes is to be expected in this tube, when the black bean passes through the light-spot. This variation in plate current of the third tube will cause a change in grid bias on the fourth tube, large enough to give an increase of at least 50 milliamperes plate current. Hence the tube can be biased to pass no current when a white bean is under the light spot; and yet, when a black bean goes under the focus of the cell, it will pass enough current to cause the relays to act. The machine is now adjusted and ready to work.

POSSIBLE TROUBLES

The only serious trouble that may be experienced is chattering of the relays; this

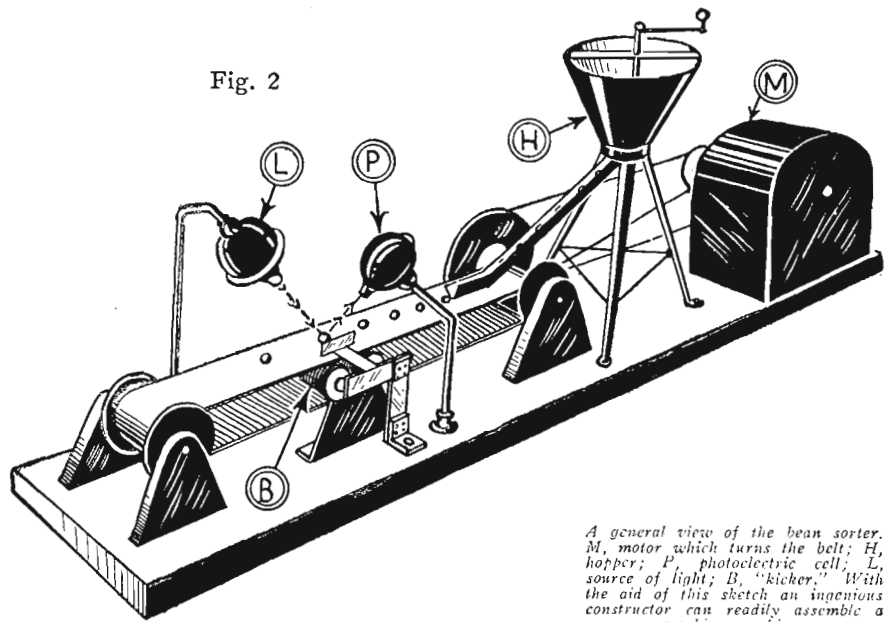

A general view of the bean sorter. M, motor which turns the belt; H, hopper; P, photoelectric cell; L, source of light; B, "kicker." With the aid of this sketch an ingenious constructor can readily assemble a working machine.

will cause the kicker to kick all the time. This trouble can be remedied by adjusting the plate current to a lower value, and by placing a 1-mf. condenser across the contacts of the first relay. It is not well to draw current from the "A" battery of the amplifier for the relays, as this may cause trouble.

A second trouble that will cause the relays to chatter is difference in the color or light-reflecting qualities of the belt. Hence it is necessary to color the belt with some finish that has about the same reflecting qualities as the surface of the white bean. In many cases, white ink will be found very satisfactory for the work.

A third possible source of trouble is the kicker. This part of the apparatus should be colored the same as the belt and the white bean. One can determine whether it is the source of the chattering of the relays or not, by inserting the milliammeter in the plate circuit of the last tube, and pushing the kicker across the surface of the belt. If the travel of this kicker across the belt causes an increase in plate current, the trouble lies in it. This may be remedied by sloping the kicker so that, on closing, it will throw light into the cell and hence

cause a decrease in plate current, rather than an increase, in the second tube.

It is well to place the machine in a room which has an even distribution of light; so that the passing of a person in front of the machine will not cause a shadow to fall on the belt or affect the amount of light on the belt. These changes in the amount of light may be so small that they are not noticeable with the naked eye, and hence one must guess at this source of trouble. Of course this effect can again be noticed in the change of the plate current of the last tube when someone steps near the instrument. If the change is not great enough to cause an appreciable difference in plate current, the machine will work satisfactorily.

The experimenter will no doubt think of other methods of making up a photoelectric machine. These can easily be worked up once one has the idea and a method of approach. The construction of the machine is not as complicated as it may sound and it makes a very interesting exhibit, when it is built. That described here was shown on Engineer's Day at the University of North Dakota, Grand Forks, North Dakota.

Radio News Free Blueprints Available for the Asking

DURING the past six months RADIO NEWS has prepared a number of blueprints showing the construction of several different types of broadcast receivers, short-wave receivers, audio-frequency amplifiers and power packs. These blueprints include full-size panel and sub-panel drilling layouts, pictorial and schematic wiring diagrams, details of coils and special components, and complete lists of the parts actually used in the outfits. They are absolutely free to the readers of RADIO NEWS; to obtain any of them all you need do is write in and ask for them.

The following blueprints are available. Simply order them by number.

No. 53, "A Simple Two-Tube Receiver,"

WRITE PLAINLY

WHEN writing for the RADIO NEWS free blueprints, please typewrite or print your full name and address clearly. Many requests which we receive cannot be filled because the handwriting is illegible or the address incomplete or missing altogether.

SEND NO MONEY. Just give the number or numbers of the blueprints you want and they will be sent to you free of cost.—EDITOR.

May, 1928 number: This set was designed specifically for the beginner in radio—the man or boy who is interested in making his own radio receiver and who wants to start with something that is cheap and easy to build. It is a "sure-fire" outfit that will work without trouble the first time it is hooked up. If you know some youngster who likes to make things with tools, send us his name and address and we will mail him a set of these blueprints.

No. 55, "An Amplifier for the Simple Two-Tube Receiver," June, 1928 number: The two-tube set mentioned in the previous paragraph is designed to work with headphones. After you get it operating satis-

(Continued on page 367)

Television in Natural Colors Demonstrated

Application of Three-Color Separation Process Used in Photography and Printing Makes Possible Transmission and Reproduction of Brightly-Colored Daylight Scenes

By *Ronald F. Tiltman**
(LONDON, ENGLAND)

THE last few months have witnessed two spectacular strides in the art of television. The first was the transmission of images, using ordinary daylight, and this has removed television from the laboratory to the open air. Any light now sufficient for an ordinary photograph to be taken is sufficient for television purposes.

This step was demonstrated by Mr. J. L. Baird in London on June 11th before representatives of the press, and subsequently before several eminent scientists, including Dr. J. A. Fleming, F.R.S., world-famous as the inventor of the thermionic valve, who described it as "a very striking advance" and "a great step forward." (See also description of American experiments, page 258, September RADIO NEWS—Editor.) Writing in a technical paper after his visit to the Baird Laboratories, Dr. Fleming referred to television as "a quite genuine and veritable scientific invention" and concluded with the words: "the writer left the laboratory with the strong conviction that it was the birthplace of new, interesting, and very important inventions."

TELEVISION IN COLOR

This demonstration was almost immediately afterwards followed by a demonstration of even more striking character. The problem of color television has at least been solved, and it was demonstrated on July

3rd for the first time to the press and to a party of scientists.

By kind permission of the British Inventor, I am allowed to publish full details of this most remarkable achievement.

At the transmitter, in place of a single exploring spiral, three spirals are used, arranged consecutively round one disc, each spiral being covered with a daylight filter. The first spiral is covered with a green filter, which allows only the green rays to pass through. The second spiral is covered with a red filter which passes only the red light. The third spiral is covered with a blue filter which allows only the blue light to pass through. (See diagram.)

As the disc revolves, the face is scanned first by the red spot of light, then by the blue spot of light, and then by the green spot of light, and the cells react to these lights, sending out first an image composed of the red parts of the picture, then an image composed only of the blue parts of the picture, then an image composed of the green parts of the picture.

At the receiving station a similar disc revolves in step with the disc at the transmitting station, and this disc has behind it, in place of the ordinary neon tube, two separate glow discharge lamps.

SUPPLYING THE COLORS

It was at the receiver that a problem immediately arose. It is obvious that the receiving disc must give a red image, a blue

image and a green image, and if the source of red consists only of red, as does the ordinary neon tube, it will be impossible for the receiving apparatus to produce blues and greens. The problem was to find a lamp which would give red, blue, and green,



Arrangement of the spirals on the Baird multiple-colored television disc.

for, as it is well known, all colors which we see are made up from red, blue and green; purple for example, is only a mixture of red and blue, yellow only a mixture of green and blue. In similar fashion, any other color can be made up by combining three primaries, or two of them, in the requisite proportions.

Thus it will be seen that it was essential to have three primary colors, and the neon tube contains only red.

The problem was solved by using two different lamps: the neon to give red, and a lamp containing a combination of helium and mercury vapor to give the blue and the green. These lamps are brought into operation by means of commutation. The neon tube operates while the spiral holes with the red filter are in use, and the helium and mercury vapor lamp operates while the spirals of green and blue are in use. Helium, it may be known to many, gives a vivid blue distil, and mercury gives a distil in green and also in blue, so that the lamp containing the mercury vapor and the helium gives a remarkable supply of these two primary colors.

At first sight one might remark: why not put mercury and neon into one tube? This is an unsatisfactory working arrangement, the neon tending to give an undue preponderance of red at one time and not enough red at another.

SUCCESSFUL TRANSMISSION

With his system Baird has been able to give demonstrations of television in natural colors. I was present at one of the demonstrations recently, and the vivid reality of the colorings was most remarkable, and adds very greatly indeed to the effect. A bunch of flowers, blue delphiniums, was

(Continued on page 374)



Mr. Baird (right) showing his television camera to an old schoolmate, Jack Buchanan, musical comedy star. Observe the light-gathering capacity of the lens, contained in the tube, behind which is the covered scanning mechanism.

* Author of "Television for the Home."

How to Build from the Schematic—Part II

Some Advice to the Set Constructor who is Getting Beyond the Beginner Stage and Wishes to Experiment



By Fred H. Canfield

IN the first installment of this article, which appeared in last month's issue of *RADIO NEWS*, the principle of the schematic diagram was explained and three important parts of a radio receiver were analyzed, viz.: the antenna circuit, inter-stage R.F. coupling circuits and the detector circuit. This concluding installment of the article will analyze other important parts of a radio circuit, and it will also show how it is possible to build a receiver entirely from the information contained in a schematic diagram.

Following the detector in a radio receiver comes the audio-frequency amplifier and, therefore, this is the next logical part of the circuit to consider. Often the A.F. amplifier is the most expensive part of the set but, fortunately, it is one of the simplest to understand. Usually there are no adjustable controls in this part of the set. The signal is passed from one tube to the next and amplified by them, additional amplification being furnished by the step-up ratio of the coupling device in the case of a transformer-coupled amplifier. The interesting thing in all amplifiers is the coupling device, which allows the signal to pass from one stage to the next, and which insulates the grid circuit of each tube from the plate circuit of the preceding tube.

A large majority of receivers now have standard transformer-coupled amplifiers (see A in Fig. 1), and the others use either resistance-coupled, impedance coupled or double-impedance-coupled circuits (see diagrams B, C and D, respectively). These circuits require practically no explanation. In the case of the transformer-coupled circuit, the primary winding of each transformer is connected in the plate circuit of a detector, or A.F. tube, and the secondary winding in the grid circuit of the following tube. A 201A-type tube is generally used in the first stage and a power tube in the last stage.

In the case of resistance, impedance, and double-impedance-coupled amplifiers three stages are usually required in order to obtain sufficient amplification; and 210-type ("hi-mu" tubes) may be used in the first two stages and a power tube in the last stage. The resistance-coupled amplifier has an .01-mf. condenser coupling the plate and grid of the tubes and resistors connected, in the plate circuit of the first tube and in the grid circuit of the second tube, respectively. When 240-type tubes are used, these two resistors each have a value of 250,000 ohms. The impedance-coupled circuit is the same as the resistance-coupled circuit, except that a plate impedance (choke coil) is substituted for the resistor in the plate circuit. This impedance is not critical in value and may be 30 henries or larger. The double-impedance circuit is also similar, except that an impedance is used in both the plate and grid circuits. Double-impedance units are manufactured for this purpose and the builder does not have to worry about the

sizes of the various parts which he is to use.

When a power tube is employed the plate current is often so heavy that it would damage the winding of the loud speaker and, therefore, a protective device should be employed in the plate circuit of the last tube. Two different types of units are used for this purpose; the first is known as an output transformer and the second as an output filter. The output transformer is a 1:1-ratio audio transformer, connected as shown at E in Fig. 1. The output filter consists of a 30-henry A.F. choke coil and a 4-mf. A.F. by-pass condenser, connected as shown at F.

CHOKES AND CONDENSERS

In all modern radio circuits it will be noticed that choke coils and by-pass condensers are connected in various positions. Frequently, these parts are not essential to the operation of the receiver, and many experimenters make the mistake of omitting them from the circuit. However, both by-pass condensers and choke coils are very important considerations, and when they are used intelligently greatly improve the performance of a receiver.

Choke coils and by-pass condensers are used frequently together, but they perform

two very different functions in a radio receiver. A choke coil is connected in a circuit where it is desired to arrest the flow of a current of a given frequency and at the same time allow direct current and current of a different frequency to pass. On the other hand, a by-pass condenser is employed to arrest the flow of direct current and permit alternating current to pass.

Both choke coils and by-pass condensers are made in different sizes for use in various parts of a circuit. For example, in a radio-frequency circuit, small R.F. choke coils having an inductance in the order of 60 to 85 millihenries and low-capacity by-pass condensers of approximately .001- to .01-mf. are used, whereas in power and audio-frequency circuits the choke coil will have an inductance from 1 henry up, and the by-pass condensers a capacity of 0.5-mf. or more.

The diagrams in Fig. 2 show several ways in which choke coils and by-pass condensers may be used to advantage in a radio receiver. Diagram A shows how a choke coil (L.) may be employed as an antenna coupling inductor where it is not desired to tune the grid circuit of the first tube. In this circuit the R.F. voltage drop across the

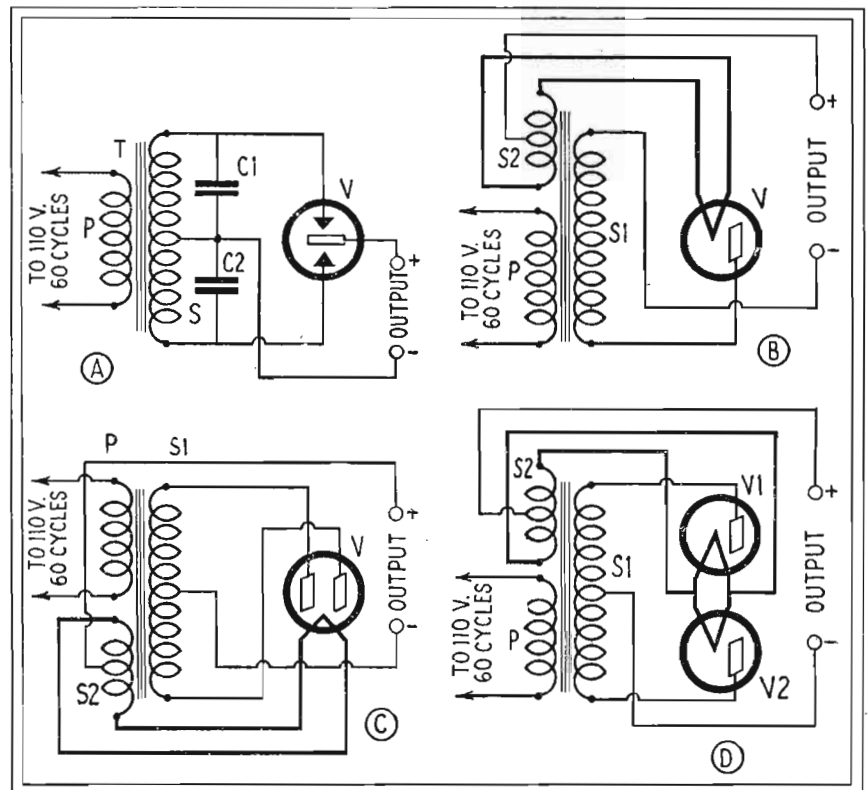

Fig. 3. These diagrams show four methods of wiring the rectifier circuit of a "B" socket-power unit. Diagram A shows the circuit used with a full-wave gaseous-type rectifier; B is the circuit for use with a half-wave filament-type rectifier; C shows the wiring for a full-wave filament-type rectifier, and D shows how two half-wave filament-type rectifiers may be used in a full-wave circuit.

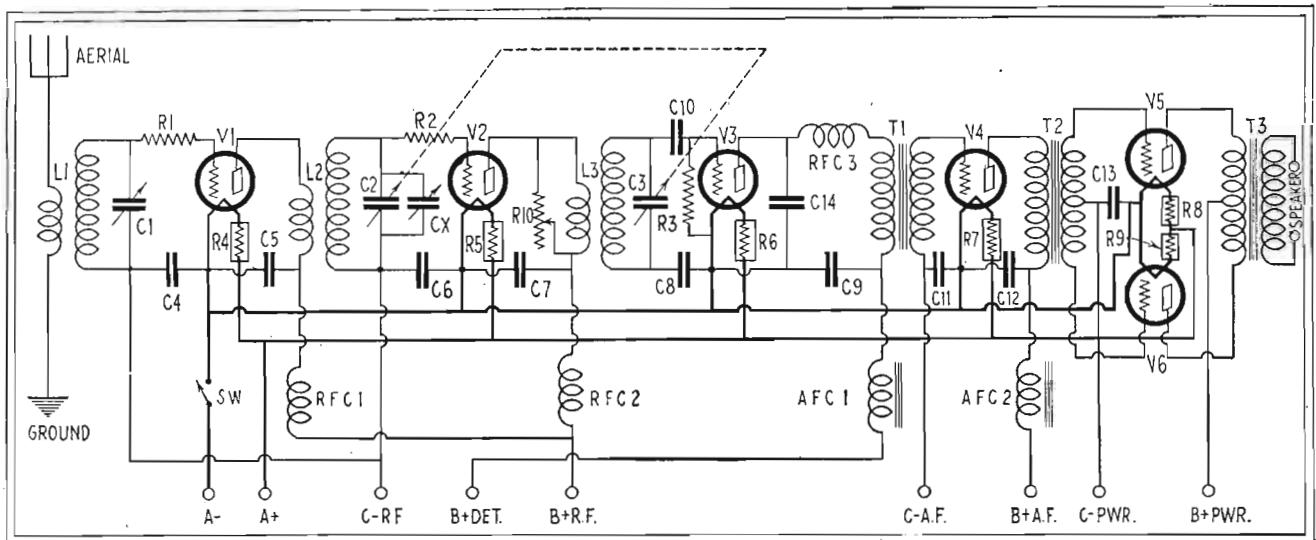

Fig. 4. This schematic diagram of a modern six-tube tuned R.F. receiver provides sufficient information to enable a well-informed experimenter to build a receiver employing the circuit. Experience would supply suitable values for each of the parts used.

choke coil produces a potential in the input circuit of the tube (V) and permits the reception of signals. Of course, the efficiency of a circuit of this type is not as high as that of a tuned circuit, but it has the advantage of eliminating one tuning control. This circuit is used frequently in multi-stage, one-control tuned-R.F. receivers where it is not desired to use a separate condenser for tuning the antenna circuit.

USES OF CHOKES

Diagram B of Fig. 2 shows how an R.F. choke coil (L) and by-pass condenser (C) are connected in the plate circuit of a detector tube. The choke coil is connected in series with the plate wire to the A.F. transformer (T) and prevents R.F. currents from entering the audio amplifier, and the by-pass condenser is connected between the plate of the detector tube (V) and the filament, to provide a low-impedance path for the R.F. energy to return to the filament. In this case, the by-pass condenser (C) should have a comparatively low capacity so that the A.F. current will be forced to pass through the primary winding of the transformer rather than go through the condenser. A condenser having a capacity of .002-mf. usually is used for this purpose.

In diagram C of Fig. 2 a method is shown for utilizing by-pass condensers and R.F. choke coils for preventing inter-stage coup-

ling through the batteries in R.F. circuits. In this circuit a radio-frequency choke coil (L) is connected in series with the plate-supply wire to prevent the R.F. energy from entering the battery or power circuits, and two by-pass condensers (C) are employed to provide a low-resistance return to the filament for the R.F. current. One by-pass condenser is connected between the filament end of the grid inductor and the filament, thus by-passing the current around the "C" battery, and the other by-pass condenser is connected in the same relative position in the plate circuit. Both by-pass condensers should have capacities of 1-mf. In diagram D the same arrangement is shown for use in audio and detector circuits. The only difference is that an A.F. choke coil is used in place of the R.F. choke coil. The A.F. choke coil which is used for this purpose need not be very large, as any choke having inductance of 3 henries or more will be found satisfactory.

THE FILTER CIRCUIT

Diagram E of Fig. 2 shows another way in which choke coils and condensers are used, but in this circuit they are called filter choke coils and filter condensers. This diagram shows a filter circuit such as is used in a "B" power unit for eliminating the A.C. hum in the pulsating direct current supplied by the rectifier tube. The choke

and condensers perform the function in this circuit as in other parts of the set with the result that the A.C. component is retarded and by-passed until practically pure D.C. is available at the output. The choke coils (L1 and L2) should have an inductance of at least 30 henries each and the filter condensers (C1 and C2 and C3) should have a capacity of approximately 4-mf. each.

A voltage-divider circuit is also shown in diagram E of Fig. 2. This consists of the three fixed resistors (R1, R2 and R3) connected in series across the output of the filter. The resistors of the voltage divider cause drops in voltage and make it possible to obtain any desired potential for the operation of the various tubes of the receiver. The exact resistance for each section of the voltage divider cannot be stated without knowing the output voltage of the power unit and the number of tubes to be operated in the receiver. However, an article entitled "Applying Ohm's Law to Radio Apparatus" which appeared on page 1348 of *Radio News* for June, 1928, gives complete details for designing various types of voltage dividers, and readers are referred to this for further information on the subject. It should also be noted that each section of the voltage divider is by-passed by a condenser to the "B—" wire. These condensers (C4 and C5) are needed to prevent coupling in the resistor circuit;

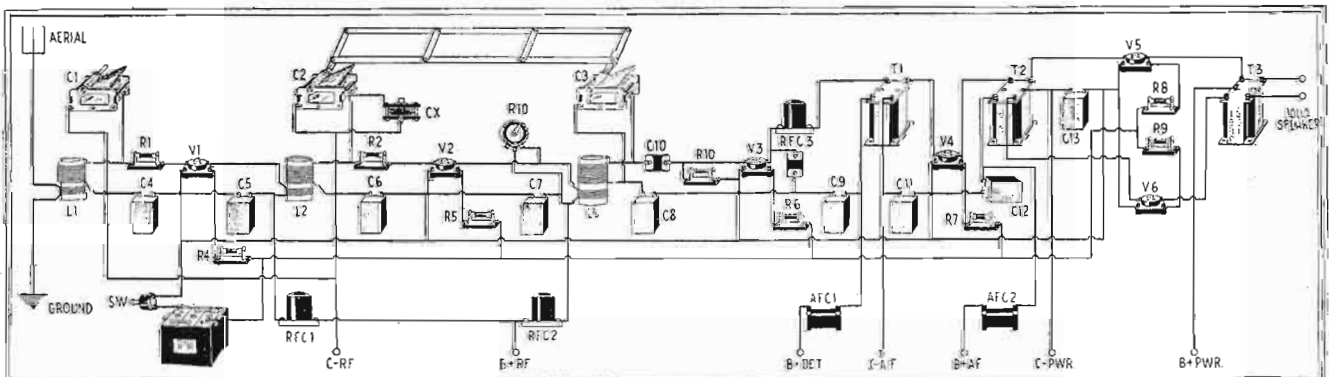

Fig. 5. The above is a pictorial diagram of a receiver using the circuit shown schematically in Fig. 4. This diagram shows the method of connecting wires to the parts specified for the receiver,

but it does not indicate the electrical circuit of the set. Without a description of the apparatus pictured it would be difficult to build from this diagram, unless the builder were able to use a schematic also.

they should have a capacity of 1-mf. each.

THE RECTIFIER

The rectifier circuit of a plate ("B") socket-power unit is practically the only part of a radio installation which has not been considered in this article. In this circuit a step-up power transformer and a rectifier tube are used to raise the house current to the proper potential and to change it to direct current. There are four different circuits of this type which are commonly used and these are shown in Fig. 3. Here we have at A the method used in connecting a full-wave gaseous-type rectifier tube to a power transformer. T is the power transformer with a primary winding (P) and a secondary winding (S). The secondary winding of the transformer is center-tapped and the two outside terminals are connected to the cathode terminals of the tube. The center-tap of the secondary is the negative high-voltage wire and the anode of the tube is the positive high-voltage wire. The condensers C1 and C2 are 0.1-mf. buffer condensers, which protect the tube from line-voltage surges.

Diagrams B, C and D show the method of connecting filament-type rectifier tubes to a power transformer. In each of these diagrams it will be noticed that the transformer is provided with two secondary windings: S1, the high-voltage winding for the plate supply, and S2, a low-voltage winding for heating the filament of the rectifier tube. Diagram B shows the connections for a circuit using a two-element (half-wave) rectifier tube of the 281 type, diagram C gives the connections for a circuit using a three-element (full-wave) rectifier tube of the 280 type, and diagram D shows the connections for a full-wave rectifier circuit using two two-element (half-wave) rectifier tubes of the 281 type.

HOW TO WORK

In the preceding paragraphs the essential parts of a radio circuit have been explained and the reader should now be ready to study a radio diagram. A two-stage tuned-R.F. receiver with all modern improvements is shown in Fig. 4. This is a six-tube set comprising two stages of tuned R.F., a regenerative detector, and two stages of trans-

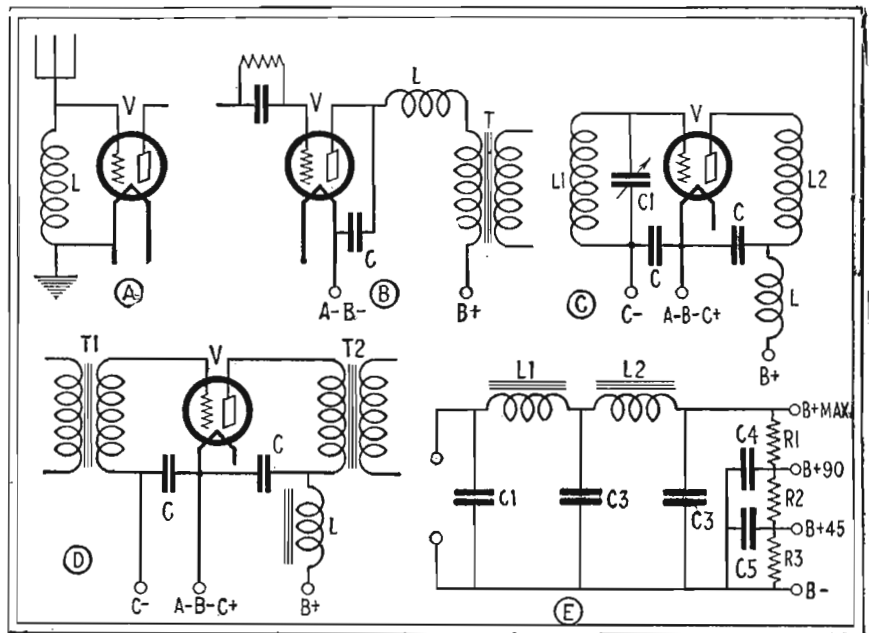

Fig. 2. By-pass condensers and choke coils may be used in numerous ways in a radio receiver, and the above diagrams show a few of the places where they may be used to advantage in a circuit.

former-coupled amplification, with "push-pull" in the last stage. All tubes are operated with a grid bias, and A.F. and R.F. chokes as well as by-pass condensers are employed to prevent coupling.

A glance at the diagram will show that the R.F. and detector circuits are standard: except that the R.F. tubes are biased and therefore extra by-pass condensers are needed. The coils L1, L2 and L3 are similar R.F. transformers, and the condensers C1, C2 and C3 are variable condensers of identical design. Oscillation is prevented by the resistors R1 and R2 in the grid circuits of the R.F. tubes. The condensers C1 and C2 are linked for one-control operation, and the small adjustable condenser (Cx) is employed to compensate for any difference between the capacity of the two tuning condensers. Another refinement is an R.F. choke coil (RFC3) in the plate circuit of the

detector, with an R.F. by-pass condenser (C14) which should have a capacity of .002-mf. C10 and R3 are the standard detector grid condenser and leak.

The audio circuit is also more or less standard. The first stage is a standard transformer-coupled circuit and the second stage employs a push-pull transformer (T2) and also a push-pull output transformer (T3.)

The by-pass condensers C4, C5, C6, C7, C8, C9, C11, C12 and C13 are A.F. by-pass condensers to prevent coupling through the batteries or power unit. These condensers are not absolutely necessary, but they are refinements which greatly improve the general operation of the receiver. The condensers should have a capacity of 1 mf. each. The two R.F. choke coils (RFC1 and RFC2) and the A.F. choke coils (AFC1 and AFC2) also help to prevent coupling through the batteries. The R.F. choke coils are of the standard 85-millihenry type, and the A.F. choke coils have an inductance of 3 henries. The resistors R4, R5, R6, R7, R8 and R9 are automatic filament ballasts regulating the supply of current to the vacuum tubes, and are of the proper size for the tubes used. R10 is a volume-control rheostat having a resistance of 75 ohms.

By comparing the schematic diagram in Fig. 4 with the picture diagram in Fig. 5 it may be seen how much more informative the former type of diagram is to the builder of a receiver, after the principle has once been explained to him.

The experienced constructor, with a schematic diagram in his hand, is ready to substitute freely any part to suit the material at hand, when trying a new hook-up. If his tuning condensers are larger or smaller than the size specified, he uses with them coils which he knows will cover the waveband. If he wishes to use a special tube in any position, he wires his set with the proper resistors and battery voltages; freely modifying the circuit in this regard. He preserves the published information

(Continued on page 373)

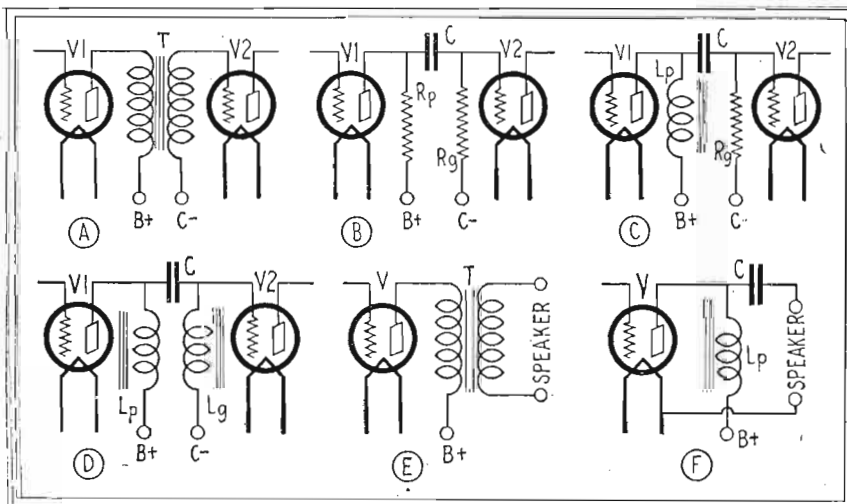

Fig. 1. Four popular A.F. amplifier systems are shown schematically above: A, transformer-coupled; B, resistance-coupled; C, impedance-coupled, and D, dual-impedance-coupled. Diagrams E and F show two types of output circuits used in with A.F. amplifiers.



The "Milk-Shaker Special" Receiver*

By the Staff of RADIO NEWS Laboratories

GETTING started in any new field of endeavor is a most difficult problem, and this observation applies to radio as much as to any other activity. After the beginner has built his first receiver he does not hesitate to add to it, as a rule, nor is he slow to provide himself with a new set when the old one becomes antiquated. However, more often than not, the newcomer in radio who contemplates the purchase or construction of a receiver considers the matter seriously for several months before he is able to decide to take the initial step. This state of mind may be likened to a man learning to swim; he is afraid of the water until he becomes accustomed to it, and then he thoroughly enjoys diving in head-first.

The "Milk-Shaker Special" receiver, described in this article, has been designed especially to answer the requirement of the average radio beginner. It was built in the RADIO NEWS Laboratories, and these three aims were constantly in the mind of the engineer in charge of its development:

First, the construction of the receiver must be as simple as possible.

Second, the cost of building the set must be reduced to a minimum.

And, third, the set must be highly efficient and of modern design.

When the completed receiver was tested, it was found that it satisfies the given conditions very satisfactorily. Therefore, its

THE fact that this receiver is called the "Milk-Shaker Special" does not indicate that it is a new-model radio cold-drink dispensary, or anything of that nature. On the contrary, it is an inexpensive, two-tube set using a screen-grid R.F. amplifier, thus equalling the ordinary two stages of R.F.; but it is easy to construct, being designed especially for the beginner. Its title is derived from the unusual character of the shields which are used in the R.F. circuits; they are simply converted beverage shakers of the variety sold in 5- and 10-cent stores. The use of these common household items in the construction of the set is one of the factors responsible for the low cost of the receiver. It may be used with any good A.F. amplifier; the "Extension" amplifier (described in the June issue of RADIO NEWS—Free Blueprint No. 55) with a 171A-type tube will be found especially well suited for this purpose.

—EDITOR.)

description is being presented in "The Radio Beginner" department, as it is considered an ideal set for the man just starting in radio.

THE CIRCUIT

A glance at the pictures, which accompany this article, will show that the "Milk-Shaker Special" receiver is of very compact design; but this does not indicate that efficiency has been sacrificed. The set comprises one stage of tuned radio-frequency amplification followed by a tuned detector circuit; the R.F. stage employs one of the new 222-type, screen-grid tubes and the detector circuit is regenerative. This combination is very simple, but it is also very sensitive and selective. With a pair of headphones connected in the detector circuit of this set it is possible to receive just as many distant stations as with the average five-tube receiver, and the set will also have the ability to separate powerful local stations.

At this point it should be explained that this receiver is not intended to operate a loud speaker. It employs only two tubes and at least two extra (audio-frequency amplifier) tubes would be required in order to provide sufficient power to operate a speaker. However, it requires but an instant to connect any standard A.F. amplifier unit externally to this receiver and under these conditions the volume and quality of reproduction obtainable from the set will equal that of any other using a similar amplifier. It should also be explained that, though this receiver was designed for operation from batteries, it may be operated from a socket-power unit if it is so preferred.

From the date presented in the above paragraphs, it may be seen that the "Milk-Shaker Special" is not a complete receiver, but merely the tuner unit. By following this plan, the designer was able to simplify the construction and reduce the cost to a very low figure. It should not, therefore be considered an undesirable feature. The tuner unit will do everything the average receiver will do, except provide volume for the operation of a loud speaker; while it may be added to at any time. It provides a modest start for the beginner and provides a future way for him to enlarge his radio installation at any time without discarding any of its parts.

SIMPLICITY OF DESIGN

Proof that the set is a beginner's receiver is found in the construction; it may be built by any individual of average intelligence, regardless of his mechanical skill or previous experience. Also, only tools of the simplest type are required. Less than a dozen small holes in the front panel are needed; and these may be drilled either with the usual hand drill or with a standard brace and machine drill. Practically all of the parts are mounted on a wooden base-

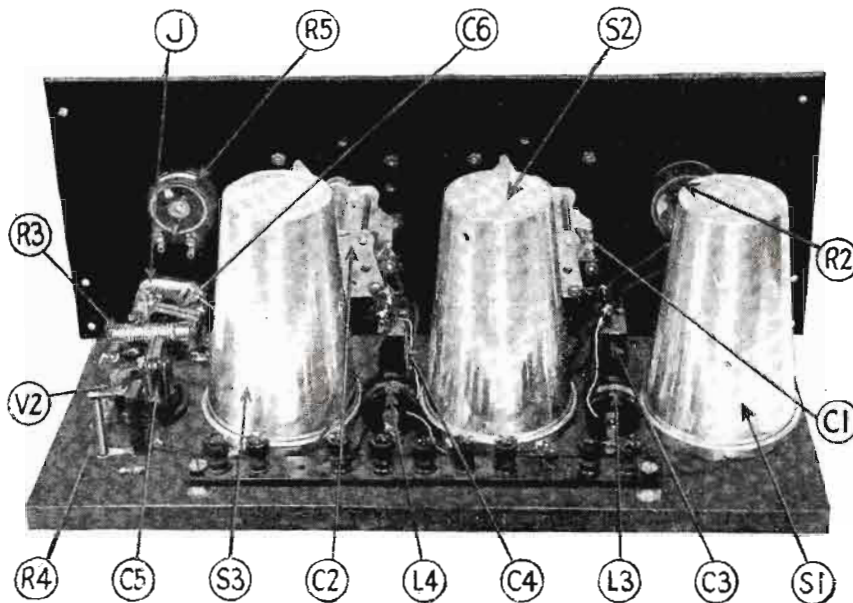

Fig. A. This rear view of the receiver shows the milk-shaker shields in place. S1 and S3 shield the antenna and R.F. coils, respectively, and S2 shields the screen-grid tube V1.

board, and fastened in place with wood-screws. There is no need for great mechanical precision in assembling the set, for slight deviations from the specifications will not affect the efficiency of the receiver. In wiring the set, flexible insulated connection wire is used; so that the builder does not have to worry about short circuits if the wires are not separated properly. Of course, all connections should be soldered; but this is really a very simple job if directions are followed carefully.

A second indication that a set is suitable for a beginner is found in its adjustment and operation. Many receivers, after their construction has been completed, require numerous adjustments before they may be used and, oftentimes, these adjustments are very delicate. In the case of the "Milk-Shaker Special," however, as soon as the wiring has been completed and found to be correct, the receiver is ready for operation. The only parts of the set which may be adjusted are the panel controls, and even these are very easy to operate. The two large dials C1 and C2, on the front panel, are the wavelength tuning controls, and these both have approximately the same setting for any wavelength to which they are tuned. The knob R2, at the left of the

- Two by-pass condensers, paper-type, 1-mf. (C3 and C4);
- One grid condenser, mica-type, .00025-mf. (C5);
- One mica fixed condenser, .001-mf. (C6);
- One antenna coupler, home-made (L1);
- One R.F. transformer, home-made (L2);
- Three R.F. choke coils, home-made (L3, L4 and L5);
- One fixed resistor, 10-ohm (R1);
- One filament rheostat, 30-ohm (R2);
- One grid leak, 2-megohm (R4);
- One filament-ballast resistor, 5-volt, 0.25 ampere (R3);
- One variable high resistor, 0-2,000-ohm (R5);
- Three shields—beverage shakers, bought at "5 and 10" store (S1, S2 and S3);
- One screen-grid tube, 222-type (V1);
- One standard vacuum tube, 201A-type (V2)
- One battery switch, (SW);
- One telephone jack, single-circuit, closed-type (J);
- One grid-leak mounting, vertical type;
- Two tube sockets, UX-type;
- Two tuning dials, 3 $\frac{7}{8}$ -inch;
- Nine binding posts;
- One terminal strip, 3/16 x 3/4 x 10-inch;
- One front panel, bakelite, 3/16 x 7 x 18-inch;

L2; and the three R.F. choke coils, L3, L4 and L5. Also, the shields, S1, S2 and S3, must be made from three beverage shakers which may be readily purchased for a few cents each. All of these parts are easy to make, and the builder is able to save considerable expense by employing his energy in this direction.

MAKING THE COILS

Winding the antenna coupler, L1, and the R.F. transformer, L2, is a very simple task. Both coils are of very similar construction and on forms of identical size; each has two windings, which are wound in the same direction with No. 28 D.S.C. wire. The coil forms are bakelite tubes, 1 $\frac{1}{2}$ inches in diameter and 3 inches in length. The antenna coupler consists of a primary coil (p) of 20 turns of wire and a secondary coil (s) of 98 turns of wire, with a space of $\frac{1}{8}$ inch between the windings. The R.F. transformer has a grid coil (g) of 98 turns and a tickler coil (t) of 40 turns, also with a space of $\frac{1}{8}$ inch between the windings. Further data on winding the coils will be found in the drawing, Fig. 2.

After winding the coils, L1 and L2, it is wise to protect their windings with a coat of insulating varnish. Collodion, which may be purchased at any drug store, is ideal for this purpose; as not only does it hold the windings in place, but it is waterproof and prevents the absorption of moisture. A small brush of the type used for water-color work may be used, and one coat should be sufficient.

Before the coil is completed it is necessary to provide terminals for the windings. A simple way to accomplish this is to drill a hole at the end of each winding and four other holes at the base of the coil form about $\frac{1}{4}$ -inch from the edge. When winding the coil three or four inches of wire should be left over at the ends of each winding, and this wire should be threaded through the nearest hole in the tube and brought to the base of the form. Then, it should be looped several times around the edge of the coil form and through one of the holes provided for the purpose. When you connect the coils in the receiver, the hook-up wire may be soldered directly to the wire

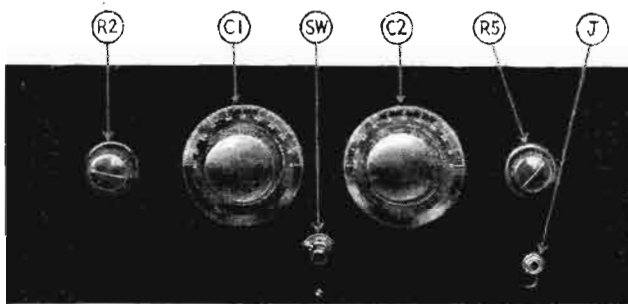

Fig. B. The two dials on the front panel of the "Milk-Shaker Special" receiver are the wavelength tuning controls. The knob R2 at the left is the volume control, and the knob R5 at the right is a regeneration control.

panel is a rheostat, connected in series with the filament of the screen-grid R.F. tube, and serves as a volume control for the receiver. The knob R5 at the right of the panel controls a variable high resistor which is the regeneration adjustment for the receiver. The small knob SW, in the center, is the battery switch which turns the set on and off.

In constructing the set, provision is also made for connecting it easily in any desired way. The phones may be plugged into the jack J in the lower right corner of the front panel or, if a separate amplifier is used, it may be connected to the binding posts marked "output" on the terminal strip at the rear of the baseboard. The circuit is so arranged that, when the phone plug is inserted in the jack, the external amplifier is disconnected automatically. To connect the set with the batteries binding posts on the terminal strip have been provided in place of the usual battery cable. This plan was considered advisable in the design of this receiver, as it tends to make the set more flexible.

COMPONENTS NEEDED

Before continuing further with the description of the receiver the parts required for its construction will be listed. The symbols printed in connection with the various pieces of apparatus correspond to the symbols used in the text and illustrations when referring to the parts. The list follows:

- Two variable condensers, .00035-mf. (C1 and C2);

- One baseboard, wooden, $\frac{1}{2}$ x 8 x 17-inch;
- Connection wire, flexible, with push-back insulation;
- Copper sheet (for base of shields).

By looking over the above list it may be seen that five parts used in the receiver must be home-constructed; these are the antenna coupler, L1; the R.F. transformer,

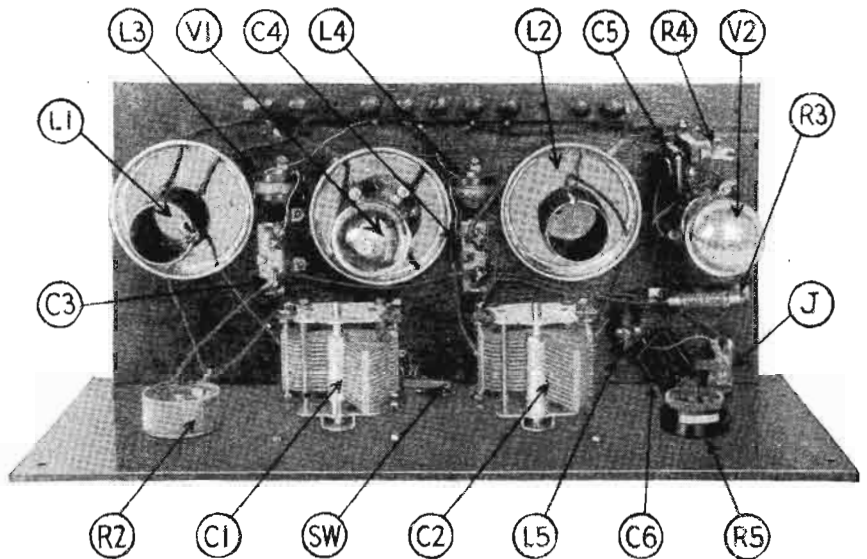

Fig. C. The exact arrangement of all apparatus on the baseboard of this receiver is shown in the top view of the set; the parts are fastened on the wooden base with wood-screws, and all wiring is in plain view. Compare with Fig. 4.

of the coil at the point where it is looped at the base of the coil form.

The winding of the R.F. choke coils, L3, L4 and L5, is even simpler than the coils just described but the job is more tedious; for there are several times as many turns of wire. Each R.F. choke coil is a single winding on a bobbin of the dimensions given in Fig. 2. No. 36 D.S.C. wire is used and the number of turns required on the coils is as follows: L3, 1,000; L4, 1,100, and L5, 900. No attempt should be made to wind the wire in layers, because the choke coil will have a higher efficiency if it is "jumble" wound. It should also be explained that the number of turns on the choke coils need not be exactly the number specified, nor is it necessary to use a bobbin of exactly the size shown; however, the specifications should be followed as closely as possible.

THE SHIELDS

Converting the beverage shakers into radio shields is not at all difficult, and the only tools needed are a hammer and a heavy pair of scissors. The cover of the shaker is

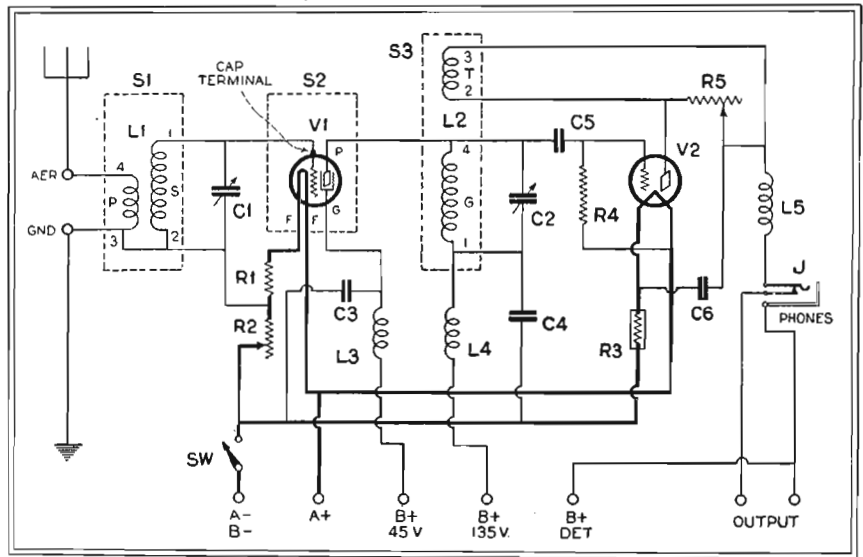

Fig. 1. Schematic diagram of "Milk-Shaker Special" Receiver.

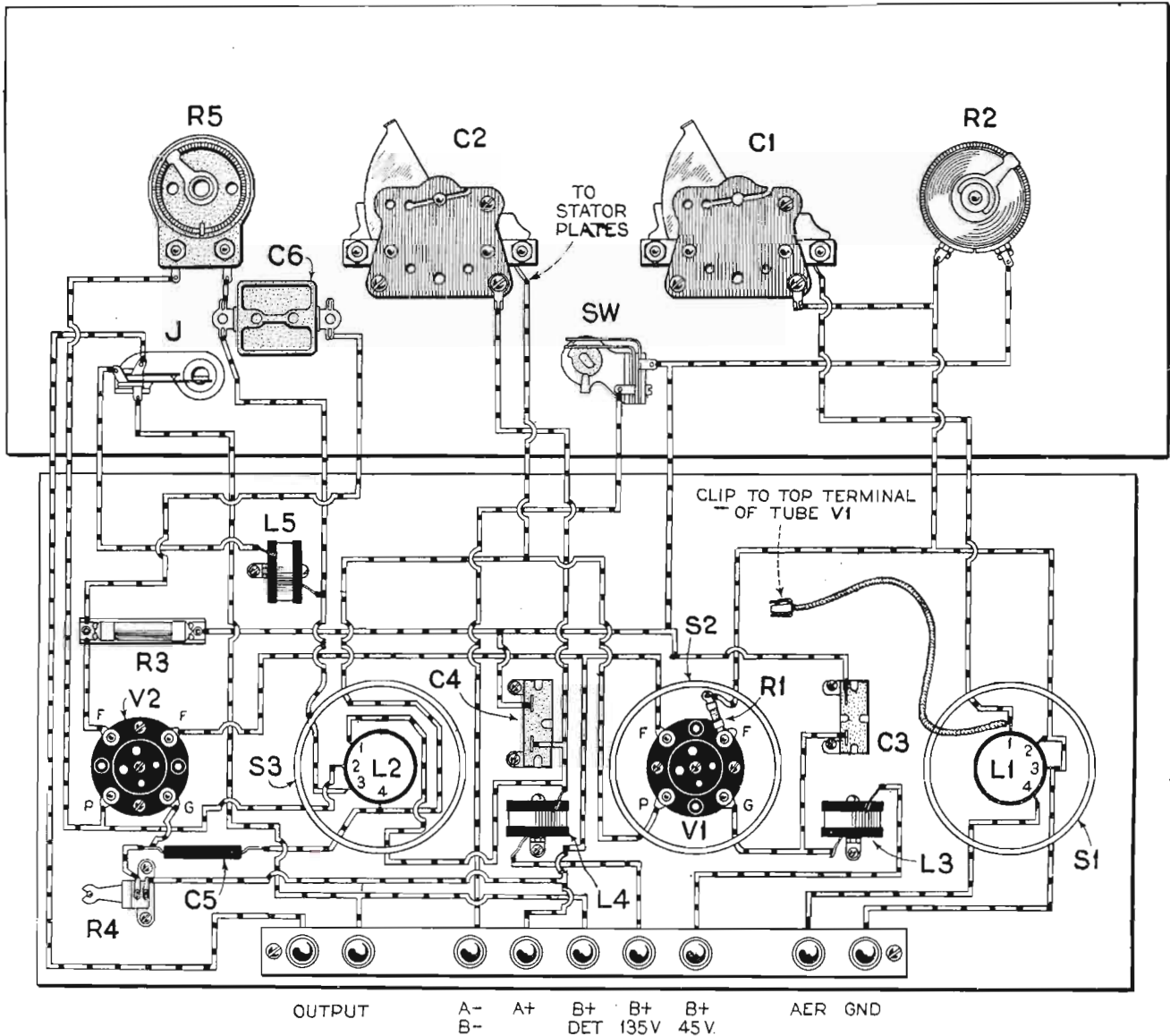

Fig. 4. All connections in the set are clearly shown in this pictorial wiring diagram. When making connections, each wire should be crossed out on the diagram with a colored pencil after it has been installed in the receiver and in this way the possibility of error in

wiring may be reduced greatly. The diagram shows all parts on the front panel and baseboard in their proper position, but slightly reduced in size in order to make the drawing more legible. The flexible lead from L1 to V1 passes through holes in S1 and S2.

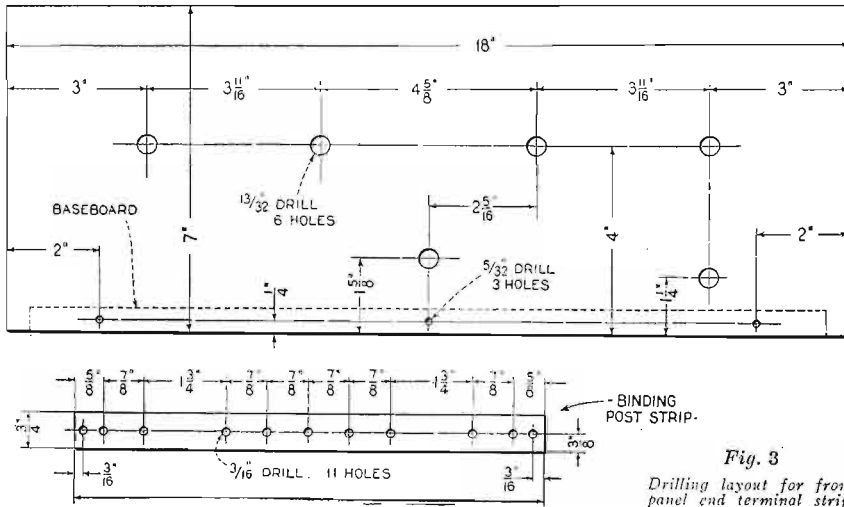

Fig. 3
Drilling layout for front panel and terminal strip.

used as a base for the shield. First the cover is cut as indicated in the drawing, Fig. 2, and then it is hammered flat. Next, a piece of sheet copper is cut to the inside diameter of the cover. To mount the shields in place on the baseboard, the base is placed in the desired position, the copper disc is placed inside the base, and nails are driven through the copper to hold the entire shield base in place. The top of the shield fits into the base and is held in position by friction.

After the shields have been made, it will be necessary to drill a number of holes for the wiring to pass through. Four holes are needed in the base of each shield, but the

position of these is best determined when wiring the set, after the shields have been

No. 64

A set of large blueprints and a list of the parts used in the construction of the "Milk-Shaker Special" receiver shown here will be sent postpaid to any applicant. See that your name and address are written or printed legibly. Ask for blueprint No. 64.

mounted. Also, a hole 1/2-inch in diameter in the top of the shield S2 is required for making contact to the control-grid terminal of the screen-grid tube; and a hole in the side of the shield cover of S1 is required for the wire which connects the coil L1 with the grid of V2.

When the construction of all the home-made parts has been completed the various pieces of apparatus may be mounted on the baseboard. First, the shield bases are fastened in place as described. S1 is located at the extreme left of the baseboard and 1 1/2 inches from the rear edge. The shields S2 and S3 are located 1 1/2 inches from the rear edge of the baseboard, and there is a distance of 1 inch between S1 and S2 and between S2 and S3. After the shield bases have been fastened in place, the coil L1 is mounted in the base of S1, the tube socket for V1 in the base of S2, and the coil L2 in the base of S3. The two coils are held in position by angle brackets, as shown in Fig. 2.

LAYOUT OF THE OTHER PARTS

The next step in assembling the set is to mount the binding posts on the terminal strip and then fasten the terminal strip in the center of the baseboard on the rear edge. The two by-pass condensers, C3 and C4, are mounted between the shield bases with wood screws in the position shown in the pictorial diagram and pictures. The rear edges of these condensers are on a line with the center of the three shield bases. The two choke coils, L3 and L4, are mounted in the rear of condensers C3 and C4, respectively.

(Continued on page 386)

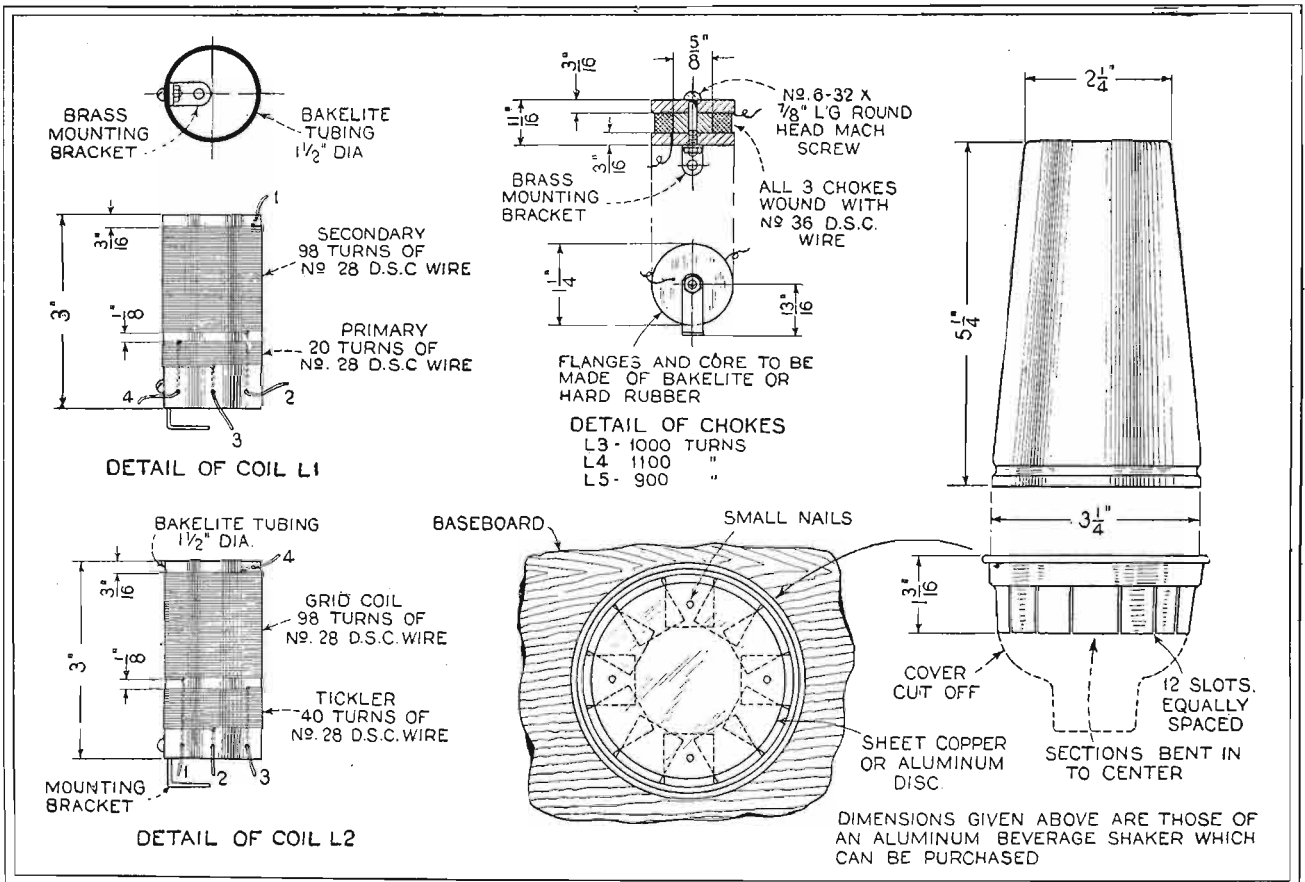

Fig. 2. The above drawing gives complete directions for constructing the homemade parts used in the "Milk-Shaker Special" receiver. The two coils and the R.F. choke coils are of very simple construction;

and a pair of scissors may be used to convert the aluminum beverage shakers into shields. The locations of the holes in these should be determined by the constructor.

The "Combine" Receiver—a \$100 Prize Winner



A Double Set Which Makes Both Standard and Short-Wave Broadcasting Available on the Loud Speaker at Will

By W. H. Scheppelle

FROM the viewpoint of circuit design the "Combine" receiver is highly efficient, but not in the least unusual; that is, the electrical system is more or less conventional and freak combinations have not been employed. However, the set possesses one outstanding feature which is both practical and novel—it may be operated at maximum efficiency on all wavelengths between 15 and 550 meters with only one wavelength tuning control.

There is nothing mysterious regarding the great wavelength range of this receiver, for, in reality, it consists of two sets—one long-wave and one short-wave—built into one cabinet. It is, nevertheless, interesting to note the compactness and simplicity of the design. The front panel measures only 7 by 18 inches, and all the parts are mounted on a baseboard 10 inches deep. These dimensions are less than those of the average broadcast receiver using an equal number of tubes, and the number of controls on the front panel does not exceed that of most sets.

Most combination sets are very complicated to operate, and have an elaborate switching system for changing from short to long waves. In this set, however, both the tuning and the change-over have been made as simple as possible. A large double drum dial is the only wavelength tuning control; one section is used for tuning the long-wave set and the other for the short-wave set. Thus, it will be seen, the receiver is single-control whether it is operated on the long or the short wavelengths. The change from long to short waves is accomplished by turning off one rheostat, turning

THE "Combine" receiver described here has the following features which will at once attract the enterprising radio constructor:

- (1) Wavelength range from 15 to 550 meters.
- (2) Quick and easy to change from long to short waves—operates on both at once, if desired.
- (3) Broadcast circuit employs three stages of tuned R.F. with non-regenerative detector.
- (4) Short-wave circuit employs tickler regeneration and tube-base plug-in coils.
- (5) Set is very compact and employs only six tubes altogether.
- (6) Single-control tuning on both long and short waves.

on another rheostat and throwing a switch which connects the aerial with the proper section of the set.

In addition to compactness, other advantages are obtained by combining two sets in the manner followed in the "Combine" receiver, and chief among these is economy. If the two sets were housed in separate cabinets, five tubes would be required for the broadcast receiver and three tubes for the short-wave set, making a total of eight tubes. However, since the two sets are mounted in one cabinet, it is entirely practical to employ the same audio amplifier for the two receivers, and in this way the same efficiency is obtained with six tubes. Not only does this result in a saving in

tubes, but the expense of building a second audio amplifier is also avoided.

SIMULTANEOUS RECEPTION BETTER

Many interesting experiments are possible with the "Combine" receiver, as it is possible to use the short-wave and long-wave sets at the same time. In this connection the writer has tried tuning in the program of WGY with the long-wave set and, at the same time, having the short-wave set tuned to 2XAF, one of the short-wave stations which transmit WGY's regular program. With the receiver adjusted in this manner, the signals may be received with excellent volume and without added distortion or interference of any kind. Also, it may be noted, oftentimes a station will fade on the long waves and not on the short waves; but with the double receiving system just described interruption to reception resulting from this cause is reduced greatly. In addition to WGY and 2XAF, there are many other stations with which the same stunt may be tried. The National Broadcasting Company programs are transmitted by the short-wave transmitter of KDKA, and these may be received and combined with any one of a dozen stations throughout the country which are transmitting the same program. WRNY, WLW and WABC are also among those sending the same program on both short and long waves, on regular schedules.

LAYOUT OF SETS

The accompanying pictures clearly show the appearance of the receiver. Fig. A is a view of the front panel of the set. In the center of the panel is the drum-dial control; the left side (C1, C2 and C3) is used for tuning when broadcast stations are being received, and the right section (C4) is employed for short-wave reception. The knob (R1) at the extreme left of the panel is the rheostat used to turn on the broadcast set, and this serves also as a volume control. The knob, SW, to the right of this rheostat, controls the switch turning on the receiver. On the right side of the set, the knob R7 is used to adjust a universal-range variable resistor, which is an oscillation control for the short-wave section of the set; and the knob R3 operates the rheostat turning on and controlling the volume of the short-wave set.

Apparatus on the baseboard of the set is shown in Fig. B. The four tuning condensers are mounted directly to the sub-base panel, near the front, with their shafts running parallel to the front edge. The condensers, C1, C2 and C3, on the front edge, are a triple unit, employed for tuning the circuits of the broadcast set. Each section of this condenser has a maximum capacity of .00035-mf., and three compensators are provided for adjusting the various sections to exactly the same capacity at any given setting. The condenser, C4, at the right of

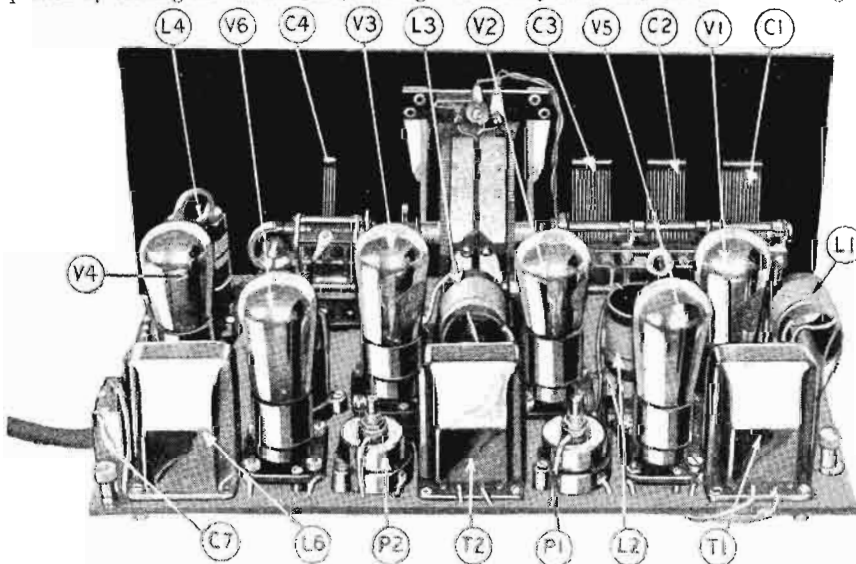

Fig. C

This rear view of the "Combine" receiver shows the set ready for use, with the tubes and coil in their respective sockets. C1, C2 and C3 is the triple condenser used for tuning the broadcast circuit of the set, and C4 the tuning condenser for the short-wave section. L4 is the plug-in short-wave coil.

* RADIO NEWS Free Blueprint Article No. 65. (See page 383 for rules of prize entries.)

the drum dial, is for tuning the short-wave circuit; it has a maximum capacity of .00014-mf.

Directly behind the variable condensers are the coils and tube sockets of the R.F. circuits. This arrangement of the parts has been found most satisfactory, as it makes possible very direct wiring and high efficiency. The small coils L1, L2 and L3, and the three tube sockets V1, V2 and V3, at the left of the sub-base, are in the R.F. circuit of the broadcast set. The tube socket V4, at the right of the panel, is the detector tube of the short-wave set, and the five-prong, UY-type tube socket, L4, is a receptacle for the plug-in coils of the short-wave circuit; L5 is a R.F. choke coil which is common to the plate circuits of the detector tubes of the two sets, and is employed to prevent the R.F. energy from entering the A.F. amplifier. The units P1 and P2 are oscillation-suppressing devices, connected in the plate circuits of the R.F. tubes of the broadcast receiver. The apparatus in the A.F. amplifier is mounted at the rear of the sub-base panel. T1 and T2 are the two A.F. transformers, and V5

ing in this part of the circuit. To control the set a filament switch, SW, is connected in the negative "A" battery wire and when turned on this lights the tubes in the A.F. amplifier. However, in order to turn on the tubes in the R.F. circuits it is necessary to turn the rheostat R1 for the broadcast set or the rheostat R3 for the short-wave detector tube. The battery switch, SW, may be used for turning off all tubes of the receiver.

The broadcast receiver comprises a more or less standard two-stage R.F. amplifier, followed by a non-regenerative detector. L1, the antenna coupler, and L2 and L3, the R.F. transformers, are home-made coils, having the same number of turns on their secondary windings, so that they may be tuned simultaneously by the triple condenser, C1, C2 and C3. L2 and L3 have the same number of turns on the primary windings, but L1 has fewer in order to improve the selectivity of the circuit. Oscillation in the circuit is prevented by "Phasatrols," P1 and P2, which are shown enclosed within dotted lines.

In connecting the output circuit of the

ticed that the grid leak, R5, is connected, not in shunt with the grid condenser, C5, in the usual manner, but between the grid of the tube and the "A+" battery wire. This plan is followed because the detector tube works best with a positive bias, and the filament side of the R.F. transformer, L3, leads to the "-A" wire because the triple condenser is connected in this way. It will also be noticed that a filament-ballast resistor, R2, is connected in series with the tubes in addition to the rheostat, R1. Connecting the resistor in this manner prevents overloading the tubes by turning the rheostat too far.

SHORT-WAVE COILS

In the short-wave circuit the most interesting feature is the plug-in coil, L4. The wavelength range of this receiver is from 15 to 200 meters and it is impractical to cover this with a single coil. Therefore, the simplest solution to the problem is to use coils of the plug-in type, which may be changed easily when it is desired to operate on another waveband. The coils in this set have three windings—primary, secondary and tickler—and are wound on bakelite forms fitted with prongs similar to those on a vacuum tube. As one wire from the primary winding is connected to one end of the secondary winding, only five prongs are required, even though the coil has three windings; and these prongs are arranged in the same manner as those of the base of a UY-type tube. Therefore, a standard UY-type tube socket is used as a receptacle for the coils.

The circuit in the short-wave section of the receiver is regenerative and of the tickler feed-back type. Tuning is accomplished by a variable condenser, C4, connected in shunt with the secondary windings; and regeneration is controlled by a variable resistor, R7, in shunt with the tickler winding T. The circuit has the usual grid condenser, C6, with a grid leak R6 in shunt, in the grid circuit; and the filament-ballast resistor R4 is connected in series with the rheostat R3 in order to prevent

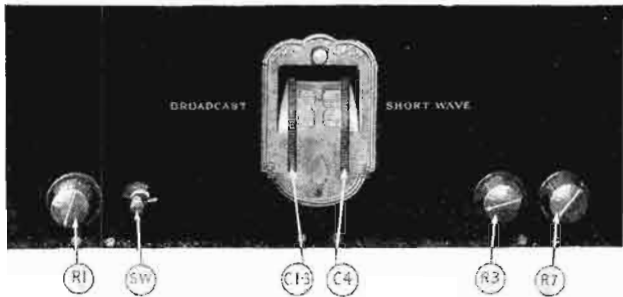

Fig. A

The arrangement of controls on the front panel of the "Combine" receiver is shown in this front view of the set. The left section of the drum dial, C1-3, tunes the broadcast circuits and the right section, C4, the short-wave coil. These are the only wavelength tuning controls.

and V6 the sockets for the two tubes; V6 is for the power tube. L6 is the output choke coil, and C7 the output condenser.

Fig. C shows the appearance of the receiver when seen from the rear. In this picture the tubes are shown in the sockets and also one of the set of short-wave coils is in its socket. An interesting feature of the receiver, which is illustrated in this picture, as well as in Fig. B, is that very little of the wiring of the set is visible above the sub-base panel. In constructing the set, holes are drilled adjacent to the binding posts on the various parts, and the wiring is passed through these and completed under the base. In this way the appearance of the set is improved greatly. Another thing which will be noticed is that the usual binding-post strip has been omitted and in its stead a battery cable is employed for making connection to the batteries. However, four binding posts are provided for connecting the wires from the loud speaker, aerial and ground.

THE TWO CIRCUITS

The complete schematic wiring diagram of the receiver is given in Fig. 1. Here it will be noticed that the receiver is divided into two distinct parts; the upper half of the diagram is the short-wave circuit followed by the audio amplifier, and the lower half gives the wiring in the broadcast receiving circuit. The aerial connects directly with a single-pole double-throw switch, SW1, making it possible to connect it easily with either of the two circuits. The output circuits of the broadcast and short-wave sets are connected with the input circuit of the audio amplifier at all times, thus avoiding the necessity of switch-

broadcast set to the audio amplifier, it will be noticed, the R.F. choke coil L5 is connected in series with the wire from the plate of the detector tube, V3, and the first A.F. transformer, T1. This choke coil keeps the R.F. energy out of the amplifier, and the fixed condenser, C8, serves to by-pass this current to the filament. It will be no-

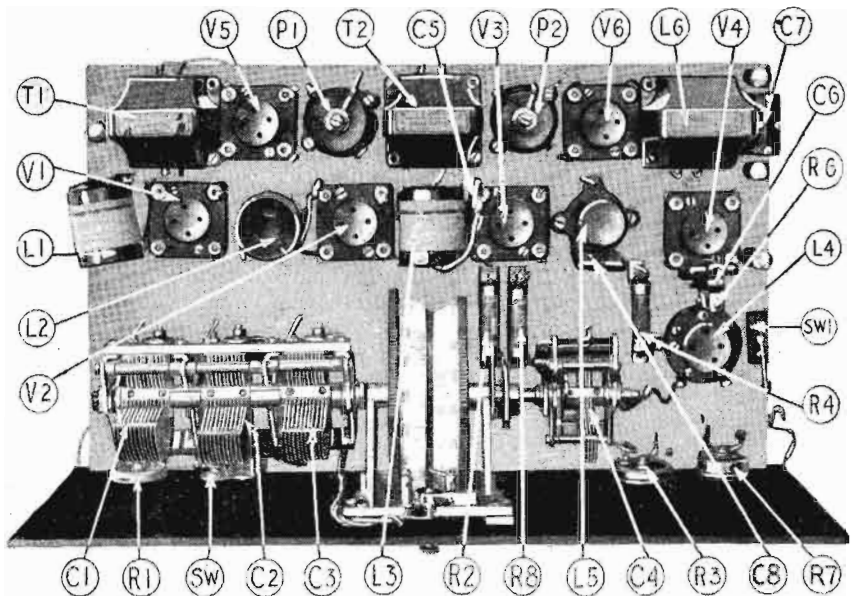

Fig. B

The exact location of all parts on the base panel is shown in this top view of the receiver. The only parts mounted on the front panel are the four knob controls and the drum dial; the remaining pieces of apparatus, including the variable condensers, are fastened to the base panel, under which most connections are made.

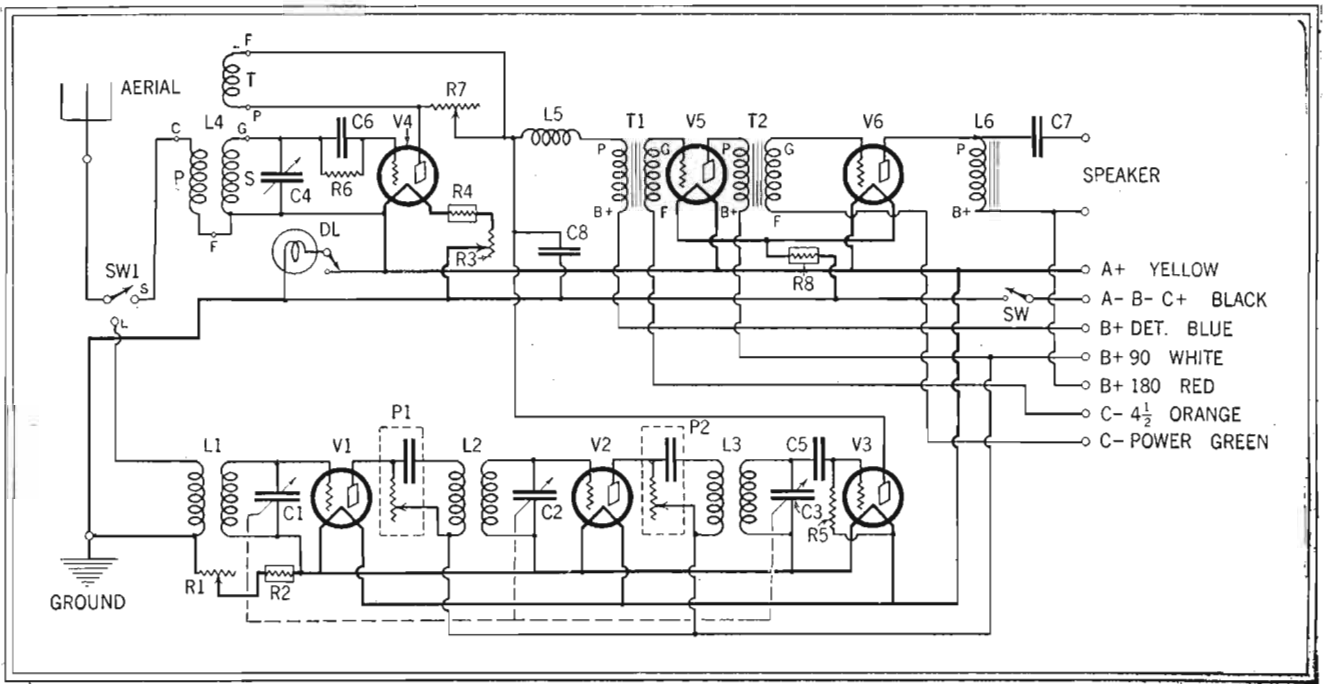

Fig. 1

The schematic diagram clearly shows the electrical circuit of the "Combine" set. This corresponds exactly with the wiring in the pictorial diagrams, below and on the opposite page. The long and short-wave tuning units the same A.F. amplifier.

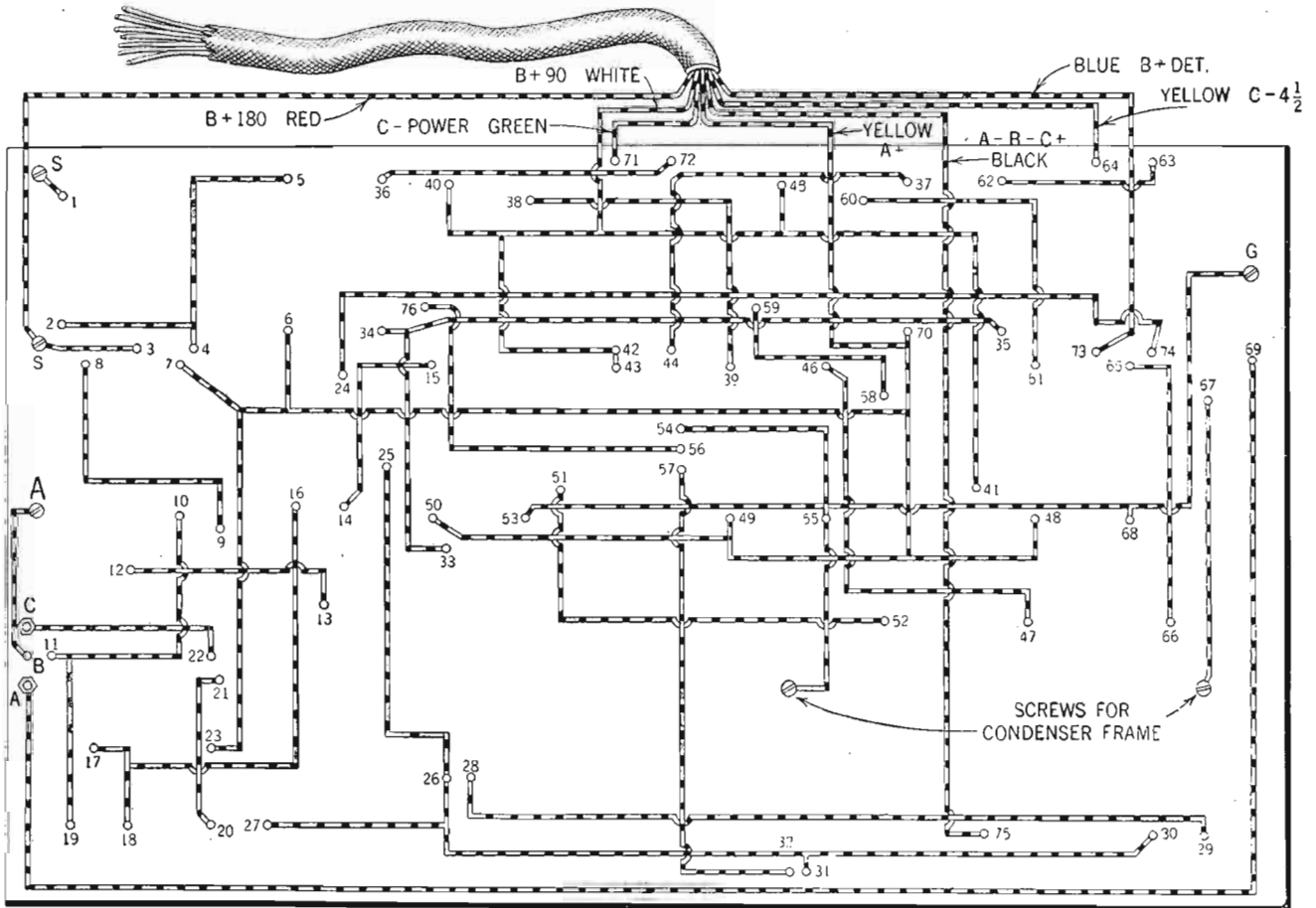

Fig. 6

Pictorial diagram of the wiring under the base panel. This diagram, together with Fig. 5, opposite, should be used by the beginner as a guide when wiring the "Combine" receiver and, as each connection is completed, the corresponding line in these

drawings may be marked off with a colored pencil. These diagrams show all of the parts in their correct relation to each other and indicate how the wires are connected to the various terminals of the apparatus and battery cable.

overloading the filament of the detector tube V4. The output circuit is connected to the audio amplifier in the same manner as the broadcast circuit; that is with the R.F. choke coil L5 in series with the plate wire, and the by-pass condenser C8 connected between the plate and the filament.

The audio amplifier of the receiver is a standard transformer-coupled circuit having two stages. T1 and T2 are standard 2:1-ratio A.F. transformers, and L6 and C7 are the output choke and condenser, respectively. Both tubes of the amplifier are biased properly, and a power tube may be used in the last stage if desired. R8 is a filament-ballast resistor to regulate the current for the two tubes.

LIST OF PARTS

The following is a complete list of the apparatus required for the construction of the "Combine" receiver:

One triple condenser with compensators, .00035-mf. per section (C1, C2 and C3);

- One variable condenser, .00014-mf. (C4);
- One mica grid condenser, fixed, .00025-mf. (C5);
- One mica grid condenser, fixed, .0001-mf. with clips (C6);
- One by-pass condenser, paper type, 1-mf. (C7);
- One mica fixed condenser, .001-mf. (C8);
- One antenna coupler, home-made (L1);
- Two R.F. transformers, home-made (L2 and L3);
- One set of short-wave coils, tube-base plug-in type for five-prong UY-type socket, four coils in set (L4);
- One R.F. choke coil, 60-millihenry (L5);
- One output choke (30-henry) L6;
- Two A.F. transformers, 2-to-1 ratio (T1 and T2);
- One rheostat, 10-ohm (R1);
- One filament-ballast unit, 5-volt, 0.75-ampere (R2);
- One rheostat, 20-ohm (R3);
- One filament-ballast unit, 5-volt, .25-ampere (R4);

- Two grid leaks, 2-megohm (R5 and R6);
- One variable resistor, universal range (R7);
- One filament-ballast unit, 5-volt, 0.5-ampere (R8);
- One battery switch (SW);
- One aerial switch, single-pole, double-throw (SW1);
- Five vacuum tubes, 201A-type (V1, V2, V3, V4 and V5);
- One vacuum tube, 171A-type (V6);
- Two Phasatrols (P1 and P2);
- One battery cable, 7-wire type;
- One front panel, bakelite, 18 x 7 x 3/16-inch;
- One sub-base panel, bakelite, 17 x 10 x 3/16-inch;
- Four binding posts, push-type;
- One drum dial, double type;
- One dial light, five-volt (DL);
- Six tube sockets, UX type;
- One tube socket, UY type (for L4);
- One grid-leak mounting for R5.
- Three pieces of angle brass, 1 x 7/16-inch (to support front panel);

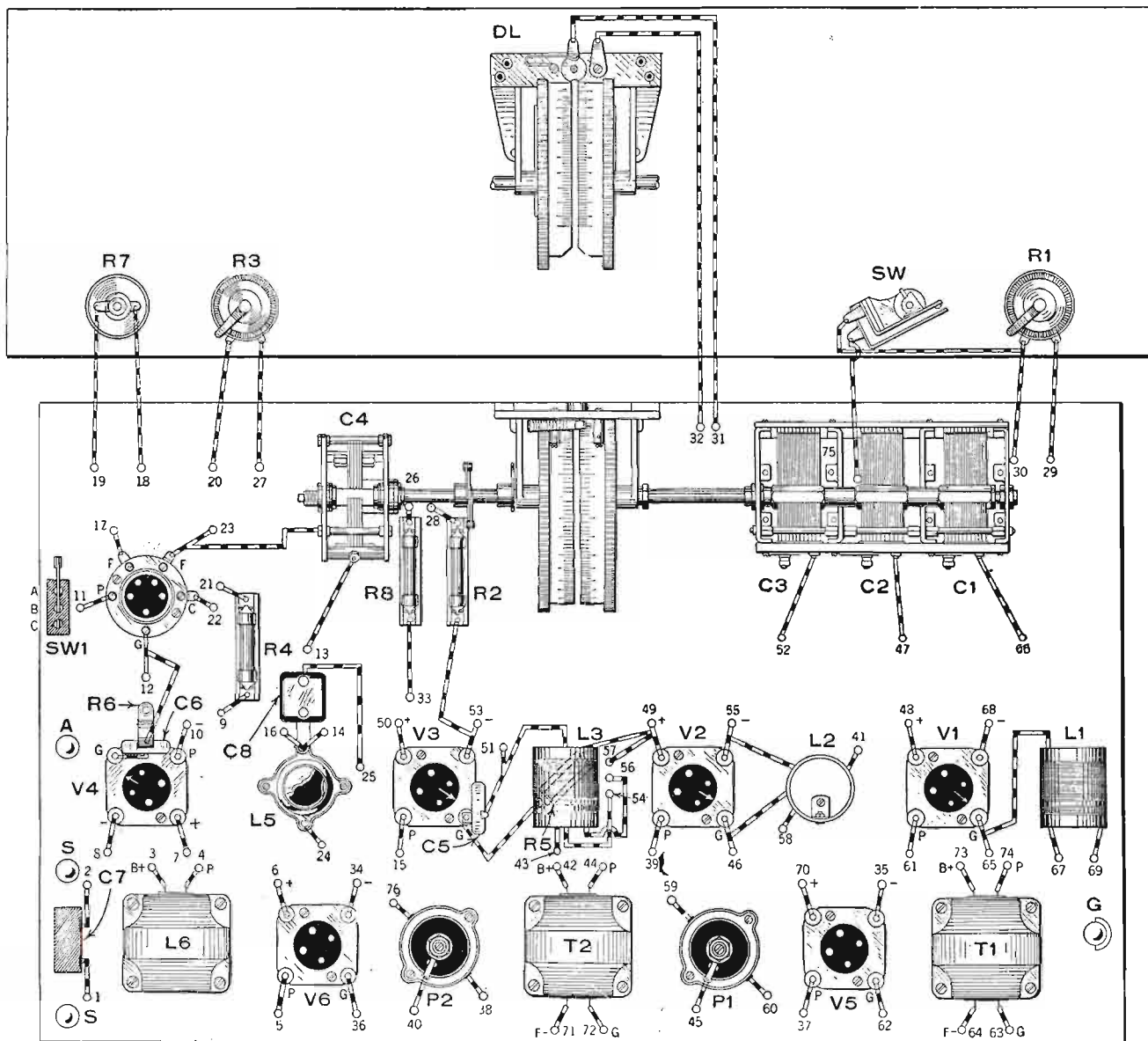

Fig. 5

Pictorial diagram of wiring above the base panel. This shows the exact method followed in the original model of the "Combine" receiver. As much as possible of the wiring is concealed under the base, and most of the wires make contact with the terminals of the

various parts by passing through holes drilled in the base panel. Each hole through which a wire passes is numbered and the numbers correspond in both diagrams. Each piece of apparatus is marked with the same symbol in the text, list of parts and all illustrations.

- Three brass brackets, 1/2 x 1 1/2-inch (to support R.F. coils);
- Three brass legs, 7/16-inch (base-panel supports);
- Connecting wire, screws, solder, etc.

WINDING THE COILS

In constructing the "Combine" receiver the first problem which confronts the constructor is securing the necessary coils. The coils for the short-wave circuits may be purchased already wound; or they may be homemade, if desired. However, the coils for the broadcast circuits must be constructed by the set builder; as manufactured coils answering the exact specifications are not available.

Data on the construction of the three coils for the broadcast set is given in Fig. 2. The drawing shows the mechanical construction, and the chart gives data on the number of turns of wire required. The coils are wound on bakelite or other composition forms 1 1/2 inches in diameter and 1 3/4 inches long, and each coil has two windings. The antenna coupler L1 has a primary of 15 turns and a winding of 80 turns. Both windings are wound in the same direction with No. 32 D.S.C. wire. A space of 1/8-inch is left between the windings.

If it is decided to make the coils for the short-wave circuit at home, their construction will be found slightly more difficult. The drawing in Fig. 2 illustrates the exact mechanical construction of the factory-made coils, and the experimenter who is gifted with a little mechanical ingenuity should be able to build duplicates from this data. Coil forms fitted with a five-prong tube base are available on the market; but if these are not at hand the base of a UY-type tube, with a bakelite tube fitted over it, may be used for the purpose. The coil form should be 1 1/2 inches in diameter and 2 1/2 inches in length. The coil form of the manufactured coils is ribbed to reduce the area of contact between the wire and the dielectric, but this is not an essential feature, although it does increase slightly the efficiency of the coil.

For tuning between 15 and 200 meters a set of four coils is required. Each coil has three windings—primary, secondary and tickler—and No. 24 D.S.C. wire is used

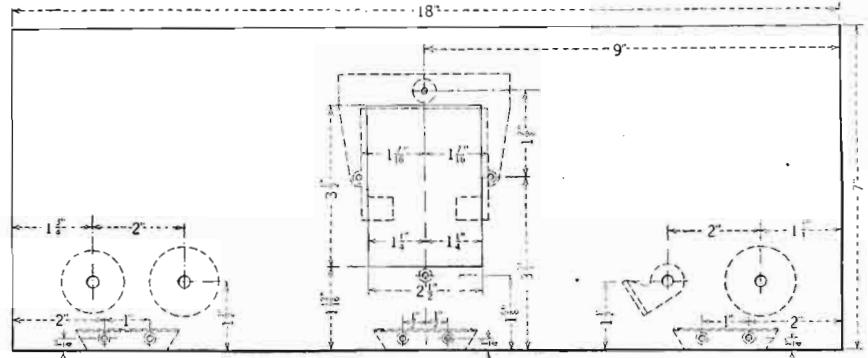

Fig. 3

This drawing shows the exact locations and sizes of all required holes in the front panel of the "Combine" receiver. Directions for cutting the large hole required for the drum dial are given in the text.

throughout. The primary coil is located near the base of the form, the secondary is wound at the top and the tickler is placed in the center. All are wound in the same direction, and a distance of 1/4- to 1/2-inch is left between each pair of windings. After the coils have been completed, they may be identified easily by painting each coil form a different color. The chart gives the number of turns required on each winding and also the wavelength range of each coil.

The next step in the construction of the receiver is drilling the front and sub-base panels. In preparing the front panel the most difficult thing is to cut the hole for the drum dial, but it may be done accurately with the template supplied with the dial. Small holes are drilled close together around the edge of the large hole, then the large hole is knocked out with a banmer. The edges of the large hole may be made smooth with a small file. All of the other small holes required in the panel may be drilled with standard drills; the exact locations, as well as the sizes of these holes, are indicated in the drilling layout (Fig. 3).

MOUNTING AND WIRING

Preparing the baseboard for mounting the parts is next in order. Fig. 4 indicates the exact location of all parts on the sub-base panel and this arrangement of parts should be followed, if possible. Measure-

ments for drilling holes in this panel are not given here, as the builder might wish to make substitutions in the parts; but a complete sub-base drilling layout will be supplied with the free set of blueprints for this set. The latter shows the exact location of every hole required for mounting the apparatus specified in the list of parts; it may be used as a template, as it is printed full size. Also, the size of each hole is specified on the blueprint.

When the drilling of the sub-base panel is complete, all of the parts, including the variable condensers, may be mounted in place. When screwing parts to the sub-base, it is important to make sure that they are fastened in the proper positions, and this is true particularly of the tube sockets and transformers. However, a careful examination of the baseboard layout (Fig. 4) will show that all identifying features of each piece of apparatus have been indicated, so that the builder should have no difficulty in this particular.

The method of mounting one or two of the parts may seem somewhat puzzling. For example, the three coils of the broadcast set, L1, L2 and L3, are supported 1 1/2 inches above the sub-base panel with brass angle brackets, and the grid leak R5 (for the broadcast set) is mounted under the coil L3, as indicated by the dotted lines in Fig. 4. The three mica fixed condensers C5, C6 and C8 are not mounted to the sub-base with screws, but held in place by the wiring.

The wiring may be started as soon as the mounting of parts has been completed. Flexible insulated wire should be used and, wherever possible, it should be run under the sub-base panel. Therefore, a number of extra holes must be drilled in the sub-panel for the wiring; the positions of these holes are shown in the set of blueprints as well as in the two pictorial wiring diagrams, Figs. 5 and 6. In wiring the set the builder may follow either the schematic diagram, Fig. 1, or the pictorial wiring diagrams, of which Fig. 5 shows the wiring above the baseboard and Fig. 6 shows the wiring under the base. Wherever the wiring passes through the sub-base in the diagrams it is indicated by the wire terminating at a circle, and the number placed next to this circle is employed to designate the continuation of the wire in the other diagram. It is unnecessary to give complete data for connecting each wire, as all details may be found in the diagrams.

The front and sub-base panels are not fastened together until after the wiring has been completed. The drilling of the front panel has been arranged so that the drum

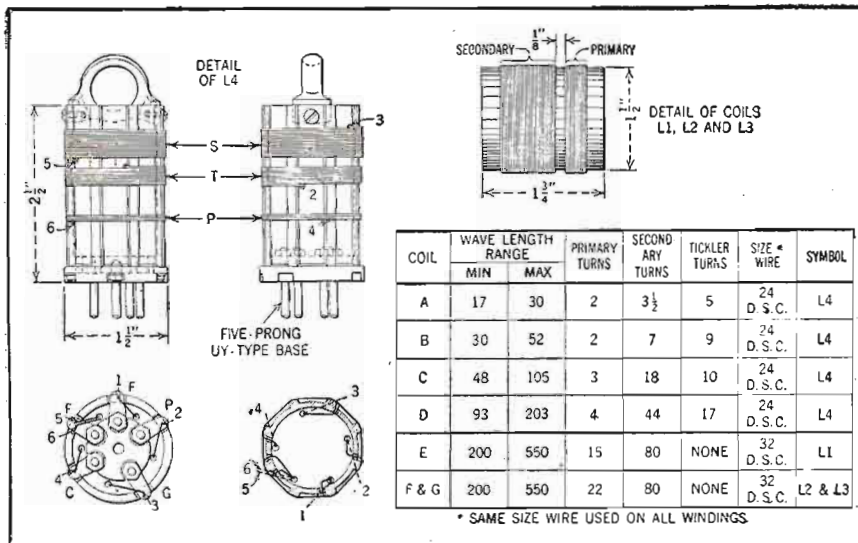

Fig. 2

The drawings and table in the above illustration give complete directions for constructing the various coils required in the "Combine" receiver. The plug-in coils may be made by using a UY-type tube base with a bakelite tube fitted over it for each coil form.

dial will meet the shafts of the variable condensers when the sub-base panel is supported 1/16-inch above the bottom of the front panel, and this provides ample space under the sub-base for the wiring. The two panels are held in this position with brass angle brackets, and the rear of the sub-base panel is supported by three small brass feet located at each side and in the middle of the base on the rear edge.

As soon as the set has been wired and assembled it should be checked carefully against the diagrams and tested. In testing the set, connect the "A" battery to the "A" leads of the battery cable and insert a tube in each of the six tube sockets. First turn on the battery switch, SW, and make sure that the two amplifier tubes V5 and V6 light. Next, with the switch turned on, advance the rheostat R1 and see that it controls the filaments of the three tubes V1, V2 and V3 in the R.F. circuits of the broadcast set, and then advance the rheostat R3 and make sure that it controls the filament of V4. After this has been done, all tubes of the set are lighted and, to complete the test of the filament circuit, turn off the battery switch and make sure that it turns off all of the tube filaments.

To test the "B" circuits before connecting the plate batteries, the "A—" binding post should be connected with the "A—" wire of the cable. Now, with the battery switch and rheostats of the set turned on and the tubes in their sockets, touch each wire of the cable to the "+" terminal of the "A" battery. The tubes of the set will light when the "A+" wire touches the binding post of the battery but, if the set is correctly wired, the tubes will not light when the "C" or "B" wires of the cable are touched to the battery. If a tube should light when a "B" or "C" wire is touched

No. 65

A set of large blue-prints and a list of the parts used in the construction of the "Combine" receiver shown here will be sent postpaid to any applicant. See that your name and address are written legibly. Ask for Blueprint No. 65.

to the battery, the set must not be connected to the batteries before locating and correcting the cause of the trouble.

ACCESSORIES AND OPERATION

Operating the receiver requires very little instruction, but there are several points which should be remembered. In the first place, inasmuch as the set is a combination long-wave and short-wave tuner it is advisable to use "A" and "B" batteries for its operation. "A" and "B" socket-power units could be used when operating on broadcast wavelengths, but on short waves considerable interference results from their use. For the "B" circuits three 45-volt heavy-duty dry batteries will give best results, and a six-volt storage battery should be used for the "A" supply.

The selection of an aerial for this receiver is another important consideration. With the average aerial of 100 to 150 feet excellent results will be secured from the broadcast circuit; but such an aerial may prove to be too long for the short-wave set. If it is found that the aerial is too large when operating on short waves first try opening the aerial switch (SW1) so that there is a

space of a fraction of an inch between the arm B and terminal C. With the switch arranged in this manner, a small capacity is placed in series with the aerial, the effective length of which is reduced greatly. Opening the aerial switch may cause too much reduction in signal strength on the short-wave set and if this is the case, a small fixed condenser should be connected in series with the aerial wire. This condenser should have a capacity of approximately .0001-mf., and may be short-circuited when receiving on broadcast wavelengths. The ground for the receiver may be the standard water-pipe connection.

It has been explained that the receiver is equipped with a two-stage audio amplifier and, therefore, is capable of providing sufficient signal strength for the operation of a loud speaker in connection with either the short-wave or long-wave circuits. However, on short wavelengths, the signals from some distant stations are weak, and it is often advisable to use headphones for tuning-in. When it is desired to use phones the builder may do so by connecting the cords to the two primary terminals, "B+" and "P," of the second A.F. transformer T2, but the phones should never be connected to the speaker binding posts; as accidentally tuning in a strong signal might cause injury to the ear of the listener as well as the phones.

After the receiver has been connected properly, the long-wave set may be adjusted for best efficiency. First, tune in a station operating on a wavelength of approximately 300 meters; i.e., in the middle of the broadcast waveband, and set the dial at the point where maximum signal strength is obtained. Now adjust the three compensator knobs

(Continued on page 382)

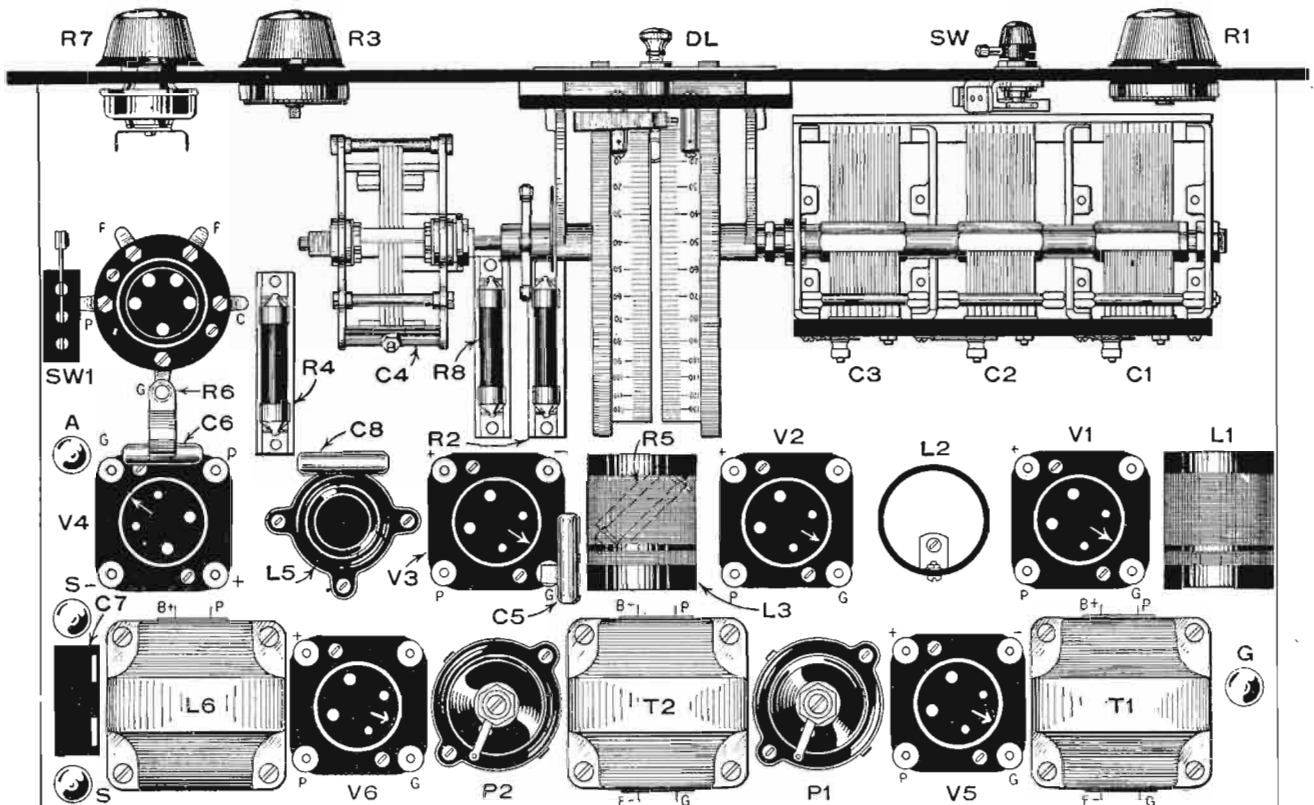

Fig. 4

This drawing shows the location of all parts on the base panel of the "Combine" set. The apparatus is shown full size, in proportion to the base. When mounting the parts

constructor should remember that they must be in the correct positions, as well as in the proper locations. This applies particularly to the tube sockets and transformers.

A Completely Shielded Short-Wave Receiver

Features of Set Are a Stage of Tuned R. F. Amplification and Wavelength Range of 10-230 Meters; Attractive Brass Cabinet Acts as Effective Shield



By Herndon Green

TWO features of interest in the short-wave receiver described in this article are the use of a stage of radio-frequency amplification, with a screen-grid tube, and the plug-in coils, which permit the reception of extremely short wavelengths. The set was originally designed by Charles Atwater, owner of amateur station 2JN, Montclair, N. J., for the purpose of conducting tests on the ten-meter band, which was recently assigned for amateur use by the Department of Commerce.

A duplicate of Mr. Atwater's set constructed in the Radio News laboratory was found to give excellent results. A few slight changes have been made in this model to simplify the construction as much as possible for the home set-builder. However, these changes have not altered the operation of the set in any way.

In order to get the greatest possible amplification from the screen-grid tube on the short wavelengths, the designer found it desirable to completely shield the entire set. This is an important point, and the builder should follow very closely the method of construction and assembly outlined in this article.

A glance at the front of the set shows that there are three adjustments or tuning controls. The large dial at the left is for the variable condenser used to tune the stage of screen-grid R.F. amplification; the one at the right tunes the grid circuit of the detector tube. The small center knob is the regeneration control. With present-

day equipment it is not practical to attempt to use single-dial control on a set designed to operate much below 50 meters, due to the extremely accurate tuning required to bring in short-wave stations. It is, of course, possible to use an untuned stage of radio-frequency amplification; however, this results in broad tuning and lack of signal strength, and the lower the wave-

length, the greater is the loss in efficiency.

The regeneration control found best adapted for use in this set is a variable resistor in the plate circuit of the detector tube. This (R5) with the by-pass condenser C6, shown in the diagram, gives smooth and even control of the regeneration which makes it possible to receive both code and short-wave phone stations

FREE Blueprints

No. 66



A complete set of blueprints showing the construction of this fine receiver will be sent free to any reader writing in for it. A list of the actual parts used in the original model is included. Write your name and address clearly. Send no money. Be sure to ask for Blueprints No. 66.

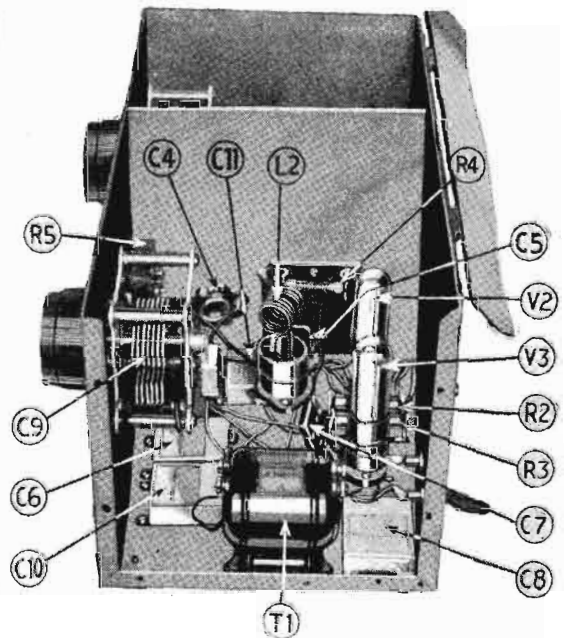

Right: A view of the detector-A.F. section with the right end of the brass cabinet removed.

without the annoying squeals and howls which are usually found in regenerative sets.

CABINET ENTIRELY OF BRASS

The cabinet is constructed entirely of sheet brass one-sixteenth of an inch thick and measures 15 inches long, 8 inches wide and 8 inches high. The constructional details are shown in Fig. 1. Brass angle strips one-half inch wide are used to hold the corners of the cabinet together and a hinged cover is provided to allow easy access to the inside.

The cabinet is divided into two compartments by a brass partition. The left-hand section of the cabinet contains the stage of screen-grid amplification, which is completely shielded from the detector and audio-frequency amplifier. In the screen-grid compartment are mounted the socket for the screen-grid tube and another for the plug-in coil, J,1, together with the variable condenser C1, radio-frequency choke coil L3, by-pass condensers, and the fixed filament resistor for the screen-grid tube.

The compartment at the right-hand side of the partition contains the detector tube, the mounting on tuning coil L2, the detector tuning condenser C9, the regeneration control resistor, grid condenser and

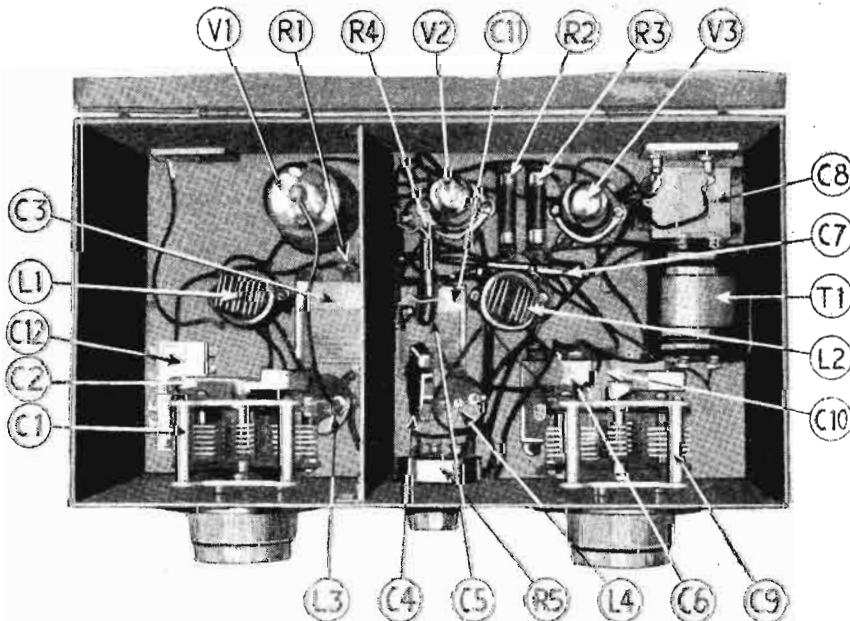

Looking into the top of the set. The R.F. stage occupies the left compartment, the detector and A.F. stages the right. Note how the two sections are separated by a brass partition; they are completely shielded from each other.

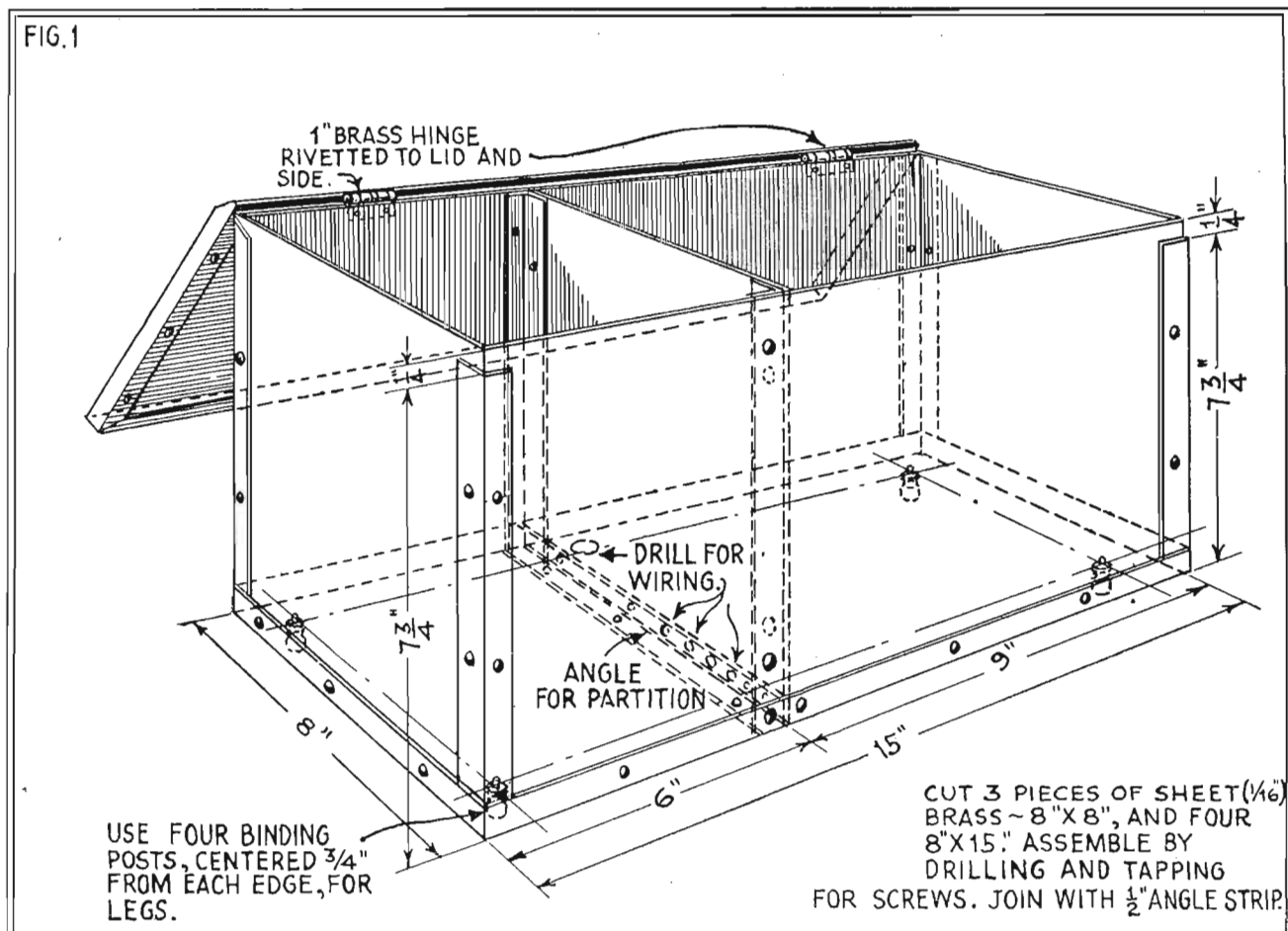

The details of the brass cabinet. The best thing to do is to have the sheets cut to the proper size by a tinsmith or machinist, who can do the work in a few minutes with a cutting press. This will cost only

a few cents and will save you much time and trouble. A brass cabinet is something unusual and not only has decided electrical advantages, but presents a rather spectacular appearance.

grid leak, audio-frequency transformer and audio-amplifier tube, together with the radio-frequency choke coils and by-pass condensers.

Another interesting feature of this receiver is that by means of the five sets of plug-in coils (ten coils in all) a wavelength range of 10 to 230 meters may be covered. If desired, an additional set of coils may be constructed to cover the broadcast band from 230 to 500 meters.

The tuning coils, two to a set for each wavelength range, are used in positions L1 and L2 shown in Fig. 2A and 2B, each consists of two windings. The windings of L1 are used as the antenna coil and the grid tuning coil of the screen-grid tube; while the windings of L2 serve as the grid coil and the tickler coil for the detector. The number of turns in the grid coil of L1 corresponds to the number of turns in the grid coil of L2, but the tickler coil on L2 has a little more than twice the number of turns used on the antenna coil on L1.

THE PARTS REQUIRED

A complete list of the apparatus required for the construction of the receiver is as follows:

- Two variable condensers, double-spaced, .000125-mf. (C1 and C9);
- Seven by-pass condensers, 0.5-mf. (C2, C3, C6, C8, C10, C11 and C12);
- One fixed mica condenser, .001-mf. (C7);
- One fixed mica condenser, .00025-mf. (C5);
- One fixed mica condenser, .006-mf. (C4);

- Two radio-frequency choke coils, (L3 and L4);
- One tapped resistance unit for filament of 222-type tube, 25 ohms, (R1);
- Two fixed filament resistors for use with 199 tubes on six volts, (R2 and R3);
- One grid leak, 1-megohm, (R4);

- One variable resistor, 0 to 200,000 ohms, (R5);
- One audio-frequency transformer, (T1);
- Three UX-type tube sockets;
- Two UX-type sockets, for the plug-in coils;
- Two vernier dials;

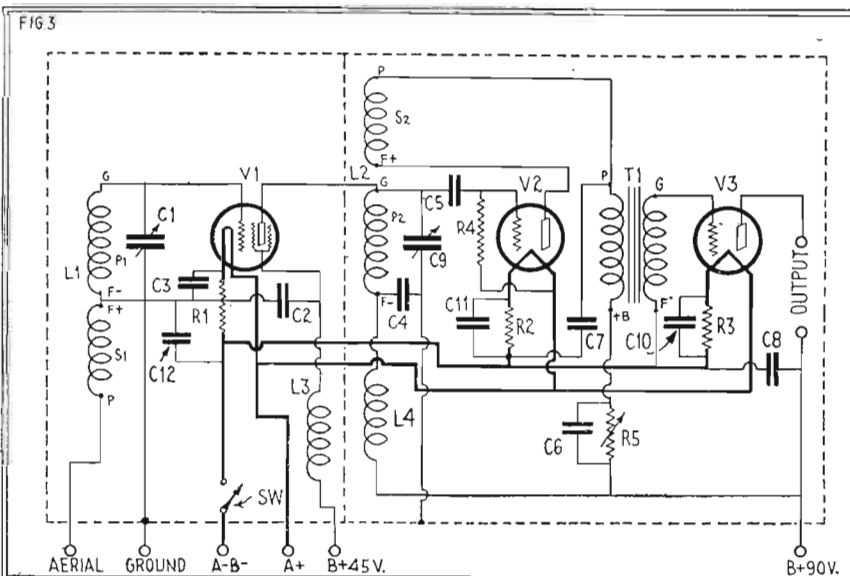

The complete schematic diagram of the receiver. The dotted lines indicate the brass cabinet, to which the tuning condensers C1 and C9 are "grounded." V1 is the screen-grid tube.

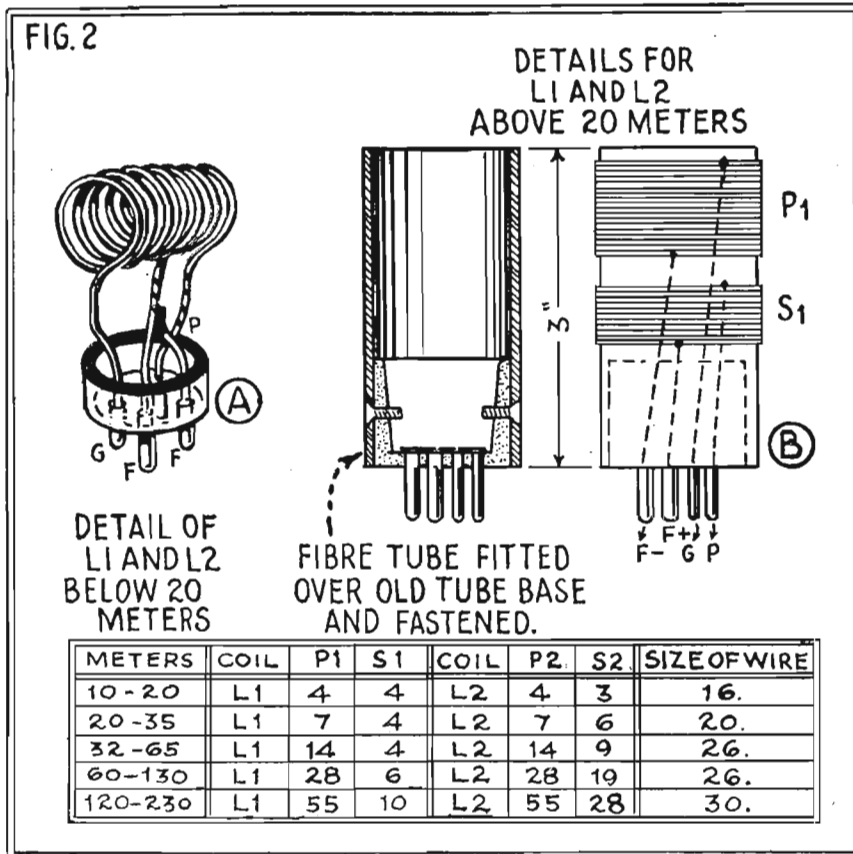

Two plug-in coils are used for each wavelength range of the set: L1 for the antenna and screen-grid input circuit, and L2 for the detector circuit. Their dimensions are given above.

- One grid-leak mounting;
- One vacuum tube, 222 type, (V1);
- Two vacuum tubes, 199 type, (V2 and V3);
- One battery switch, SW;
- Four binding posts;
- One four-wire battery cable;
- Two tip-jacks;
- Five sets of plug-in coils, home-made, (for L1 and L2);
- Twenty-five inches of bakelite tubing, 1 3/8 inches in diameter, for the home-made coils L1 and L2;
- Ten UX-type tube bases;
- Four brass panels, 15 x 8 x 1/16 inches, (for top and bottom and front and back of cabinet);
- Three brass panels 8 x 8 x 1/16 inches, (for ends of cabinet and partition);
- Nine feet of 1/2 inch brass angle strip, to hold edges of cabinet together.

All of the parts mentioned in this list are standard, with the exception of the plug-in coils. Factory-made forms may be used for these, if desired, but the winding should be done at home.

CONSTRUCTING THE COILS

The ten short-wave coils are constructed as shown in Fig. 2. The base for each of the coils may be obtained from a burned-out or defective UX-type tube. All of the glass should be removed from the base by heating the sealing compound, while the wires may be removed from the four prongs by means of a hot soldering iron. The tubing on which the wire itself is wound should have an inside diameter of one and three-eighths inches, which will just fit over the outside of the tube base. The tubing should be cut up into 3-inch lengths and fastened

over the tube bases with small machine screws and nuts. The winding is started about one-eighth of an inch from the top of the tube. Each of the eight coils has two separate windings.

The two largest coils have a wavelength range of 120 to 230 meters. In order to get the desired number of turns on these coils it will be necessary to use No. 30 D.C.C. wire. The winding is started at the top of the form and 55 turns are used for coils P1 on L1 and P2 on L2, for the first set of coils. A space of one-eighth of an inch is then left and ten turns are wound on L1 for the coil S1. This serves as the antenna coil. The second coil, S2 on L2, is wound in the same manner but in this case the winding consists of 28 turns, and is used for the tickler coil.

The start of the winding, P1, is connected to the prong in the tube base which was originally connected to the grid of the tube. The end of this winding is connected to the corresponding filament prong, F-. The upper end of S1 is connected to the plate prong, while the other end of this winding goes to the remaining filament prong, F+. All eight coils are wound in exactly the same manner and all are connected alike, the only difference between them being in the number of turns of wire on them.

The two coils comprising set No. 2, have a wavelength range of 60 to 130 meters. Due to the fewer number of turns required, a slightly larger size of wire may be used to advantage for these windings. The coils in the set shown here were wound with No. 26 D.C.C. The coil P1 on L1 consists of 28 turns, with six turns in S1. On L2, 28 turns are used for P2 with 19 turns in the tickler coil.

No. 3 is wound with No. 26 D.C.C. wire and No. 4 with No. 20 D.C.C. wire. P1 on L1 in set No. 3 consists of 14 turns, with 4 turns in S1, while the P2 on L2 consists of 14 turns with nine turns for S2. This set covers the wave band from approximately 32 to 65 meters. The upper winding P1 on L1 in coil set No. 4 consists of 7 turns with 4 turns in the antenna coil; while the two windings on L2 consist of 7 and 6 turns, respectively. These two coils are used for stations operating in the band between 20 and 35 meters.

THE 10-METER COILS

The coils L1 and L2 used in set No. 5 are designed to cover the band between 10 and 20 meters. They are self-supporting, being wound with No. 16 bare copper wire. Details of the construction of coil L1 are shown at Fig. 2A. It is first wound on a form one inch in diameter, with the turns spaced about one-sixteenth of an inch apart. Seven turns are used and a tap is taken from the mid-point on the winding and connected to the two filament prongs on the tube base. The start of the winding is connected to the G prong, while the last turn connects with P. Coil L2 consists of two separate windings, space-wound and self-supporting, following the same method of construction used for L1. Coil P1 has four turns, while S2 has 3 turns.

Two radio-frequency choke coils are required, L3 and L4, shown in the diagram, Fig. 3. The ones used in the receiver shown in the illustration were factory-made. However, home-made ones will give just as good

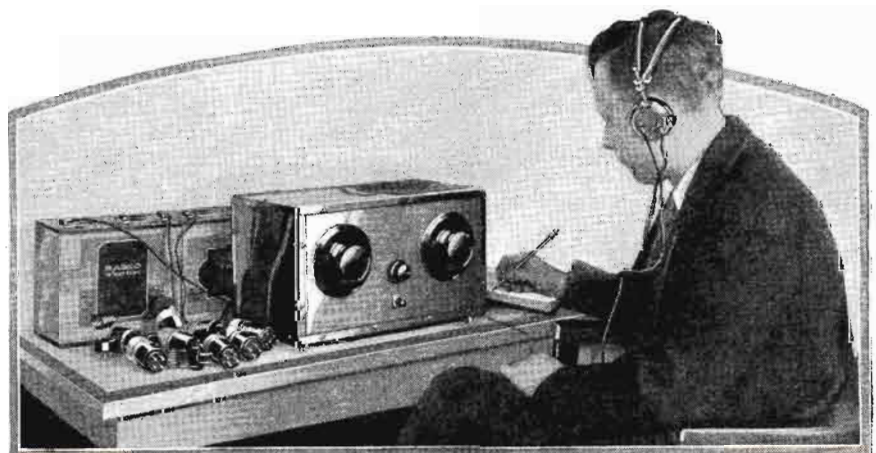

This picture cannot do justice to the fine appearance which the brass cabinet presents. The constructor will be proud to show this receiver to his friends.

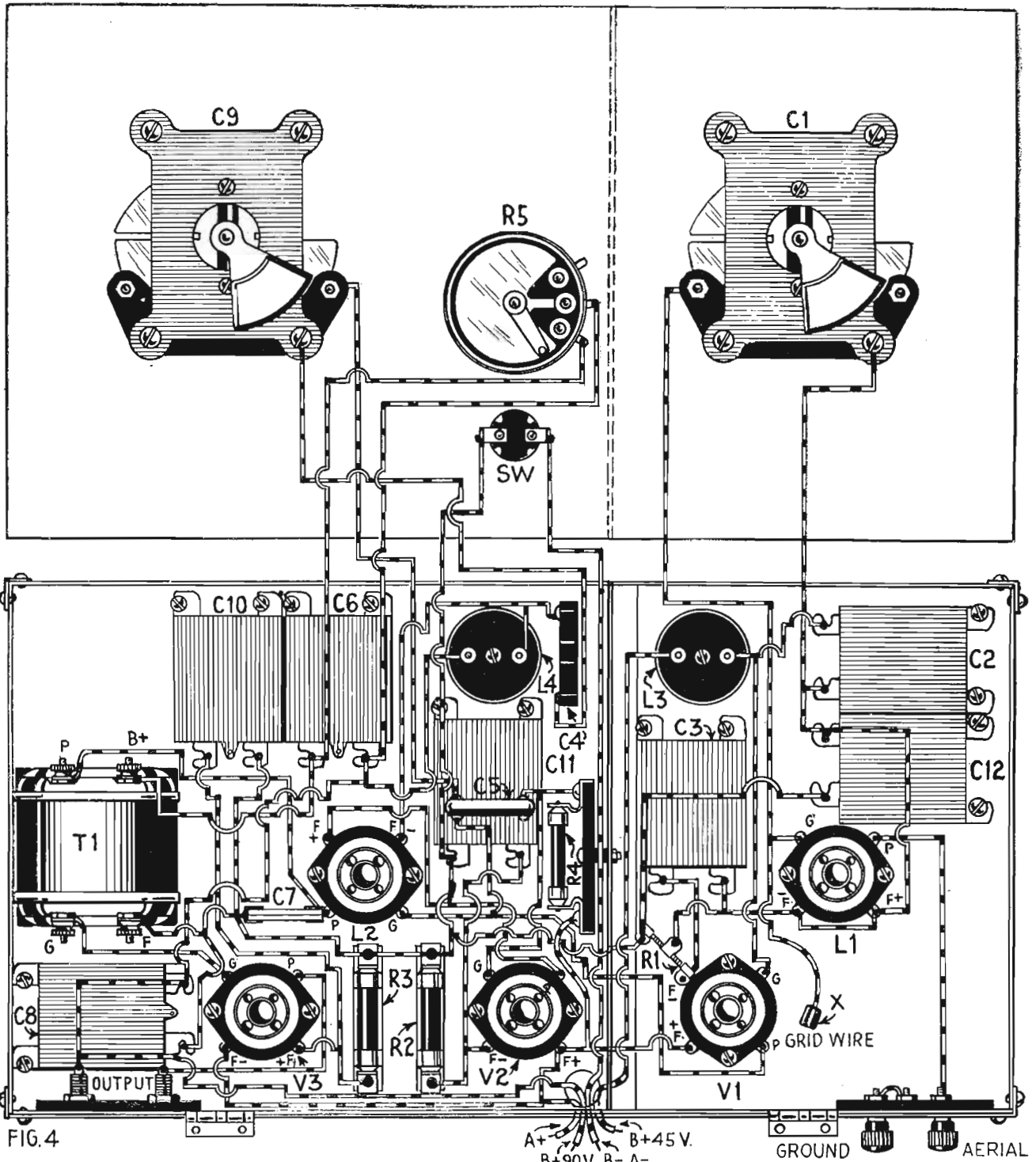

FIG. 4

This drawing shows every wire in the set. In order to keep them clear, the draughtsman has separated the leads considerably and made them turn and cross irregularly. Actually, the wires should

be as short as possible; particularly the grid leads. The wire marked X connects to the brass cup on the screen-grid tube. Study this carefully before you start soldering and you will have no trouble.

results. If home-made, they should consist of approximately 50 spaced turns of No. 30 wire on a form one inch in diameter.

WIRING THE SET

The layout of the parts and wiring of the set is shown in Fig. 4. The only parts mounted on the panel are the two variable condensers, C1 and C9, the regeneration control resistor, R5, and the battery switch, SW. Their arrangement and the position of the mounting holes is shown in Fig. 5A.

The arrangement of the parts within the cabinet is shown in Fig. 4. While it is not

necessary to follow this layout exactly, it is important that all leads be kept as short and direct as possible if good results are to be obtained on the very short wavelengths, for which this receiving set was designed. Machine screws are used to hold the parts in position.

A four-wire battery cable in place of the usual array of binding posts is used to connect the batteries with the set. Two bindings are mounted on an insulating strip at the back (drilled as in Fig. 5B), for aerial and ground connections. The aerial binding post is connected to post P on the tube

socket used for the coil mounting L1. The ground binding post is connected directly to the brass cabinet. The mid-tap of the filament resistor R1 is also grounded to the cabinet, as shown in Fig. 1. A second insulating strip mounted at the opposite end of the cabinet holds two pin-jacks for the phone tips.

Fixed filament resistors are used to reduce the number of adjustments on the set to a minimum. The model illustrated was designed to operate direct from the usual six-volt storage battery. The resistor con-

(Continued on page 354)

The Search for the Perfect Amplifier

Encouraging Results Obtained by British Experimenter in the Development of Unusual Circuits with Inputs on the Filaments and Outputs on the Grids

By Sydney P. O'Rourke

IN the January issue of Radio News, under the heading, "The Search for the Perfect Detector," the writer described a novel method of rectification differing very considerably from the usual circuits; the radio-frequency input was applied to the filament, the A.F. output being taken from the grid and the whole tube was regulated by the plate, suitably biased.

In the present article the writer will give practical details of a new amplifier circuit which the above system has made possible.

Firstly, it will be necessary to reiterate briefly the advantages and utility (or otherwise) of the various conventional forms of audio-frequency inter-tube coupling, examine where each one fails, and finally endeavor to define the requirements of the ideal amplifier.

TYPES OF COUPLING

First and foremost in popularity among all A.F. coupling devices ranks the simple and efficient transformer. This much-used and abused component has received much attention from manufacturers and now there are many first-class articles on the market capable, if properly used, of giving practically perfect reproduction from about 100 to 5,000 cycles with a useful amplification of about 30 to 40 per stage.

The success of this type of coupling depends almost entirely upon the quality of the transformer, a cheap instrument being practically useless for quality reproduction.

Resistance-capacity coupling next claims our attention.

The popularity of this method has increased by leaps and bounds during the past several years, due to the introduction of efficient metallized resistance units and special "high- μ " tubes. This type of coupling is highly favored for true-purity amplification; a straight-line amplification curve from about 50 to 5,000 cycles and an over-all voltage amplification of 20 to 30 per stage are obtainable if values are properly chosen.

Lastly, choke coupling in its modern form, usually called double-impedance coupling, is rapidly gaining in popularity. It may give a frequency curve equal to any resistance-capacity coupling, with less of the latter's bugbear of voltage drop across the plate resistor.

For further information on these various forms of coupling the interested reader is referred to other articles which have appeared in Radio News from time to time, and particularly to that on page 1140 of the April, 1928 number. Suffice it to say that, in nine cases out of ten, it is the coupling itself which introduces any uncontrollable distortion, slight though it may be.

HOW ELIMINATE DISTORTION?

What, therefore, will constitute our ideal amplifier, if such is at all possible with

RADIO fans can spend an interesting evening experimenting with the novel audio-amplifier circuit described in this article. The hook-up is totally unlike any of the standard arrangements; the tubes being actually connected backwards and coupled directly to each other.

RADIO NEWS would like to hear from readers who try this circuit or any similar hook-ups it might suggest.

existing apparatus? It should be able to amplify reasonably well and equally every cycle from 25 to 10,000; these figures cover all the fundamental notes and harmonics audible to the average ear.

Hence, until some new form of coupling is discovered, we must rule out all the usual circuits and take our detector output direct to the input of the first A.F. tube.

This cannot be accomplished easily in conventional circuits, since the positive "B" potential would be applied not only to the output plate, but also to the following

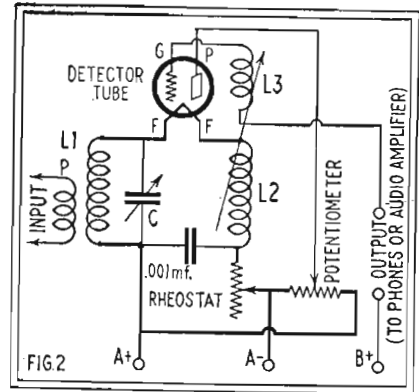

The author's filament-input detector circuit, described in his preceding article.

input grid; which would of course render that tube completely inoperative, except under special conditions of operation.

Having seen that, at present, direct coupling is the only cure for coupling distortion, let us go back for a few moments to the filament input circuit of Fig. 2.

Considering the greater efficiency of this circuit compared with standard grid-input detectors, the writer has recently been following a very interesting line of experiment in endeavoring to employ this "input to the filament" principle to work a tube as an audio-frequency amplifier.

That this should be possible is quite evident if one examines the "straight" portion of a curve obtained from a Fig. 2 circuit. A moment's consideration would suggest chokes to isolate the filament, as in the detector circuit; these would have to be A.F. chokes, however, and would obviously be out of the question for carrying the "A" battery current to and from the filament.

THE FIRST EXPERIMENT

These, then, were definitely excluded from the start and the circuit of Fig. 3 developed as a "possibility."

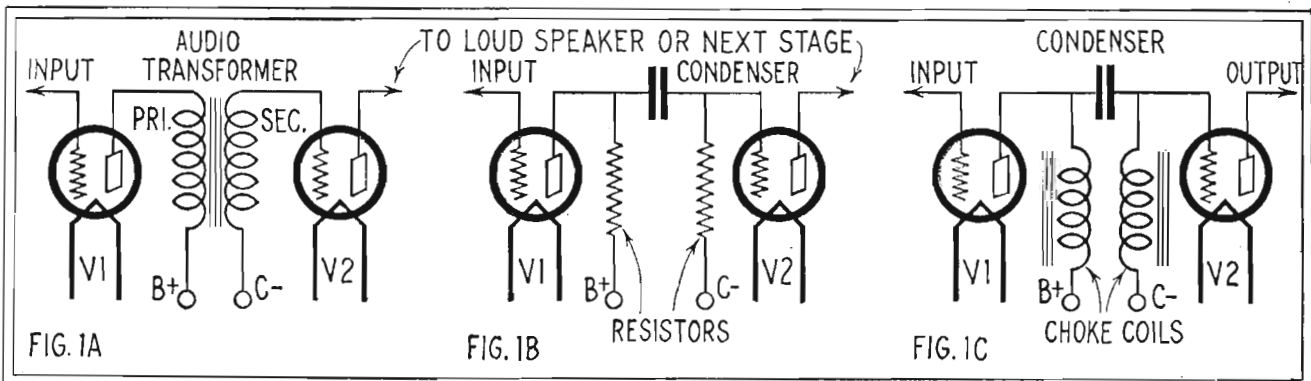

Each of the three well-known methods of A.F. coupling, in order to isolate the grid from the preceding plate voltage, introduces a device which favors certain audio frequencies at the expense of others. The problem of remedying this is a grave one.

Transformer coupling was selected to start with. Notice that the end of the secondary opposite to that connected to the filament as input is connected, not to the "A" battery, but to "B—" only. If "B—" were connected to the "A" battery, the impracticability of the circuit would

THE CONCLUSION

Fortunately, this is not so by any means. The theoretical diagram of the final circuit is shown in Fig. 4. I will say nothing further of what the circuit will do except to state that, quite unusual though it appears,

it will give any fan who cares to hook it up an agreeable surprise.

Finally, a few words upon the operation and working details of the circuit. Correct values and voltages must be adhered to throughout for best results, although no adjustment is super-critical in any way.

Let us run briefly through the details of Fig. 4.

Each of the two parallel coils L1 and L2 should be slightly larger than a single coil in the usual circuits. Thus, if at present, to cover a certain band of wavelengths, you are using a single coil of say 50 to 60 turns, then in this circuit you should use two coils of 70 to 80 turns each, *not coupled*, to cover the same wavelength band; L3 may consist of a coil of 45 to 75 turns coupled to L2.

Regeneration is controlled simply by the potentiometer P wired across the "A" battery. If L3 is adjusted correctly with respect to L2, the feed-back action will be found delightfully smooth and easy.

Now we come to the amplifier tube. Leaving the plate disconnected for the moment from the "B" battery, turn the rheostat full "on"; signals should be fairly good now if everything is all right. Now connect the plate to about 10 volts positive on the "B" battery; then lower the filament rheostat until a point is reached when the volume of signals will increase enormously.

Lowering the rheostat any further will result in horrible distortion but, at the correct point as above, volume and quality seem perfect. Finally, for maximum results, the "B" voltage should be increased or decreased in sympathy with the rheostat until the tube is taking its correct filament voltage and current.

The voltage is not critical and may vary according to the tube and the A.F. choke separating the "A" and "B" batteries; if this choke were omitted, the input and output (Continued on page 356)

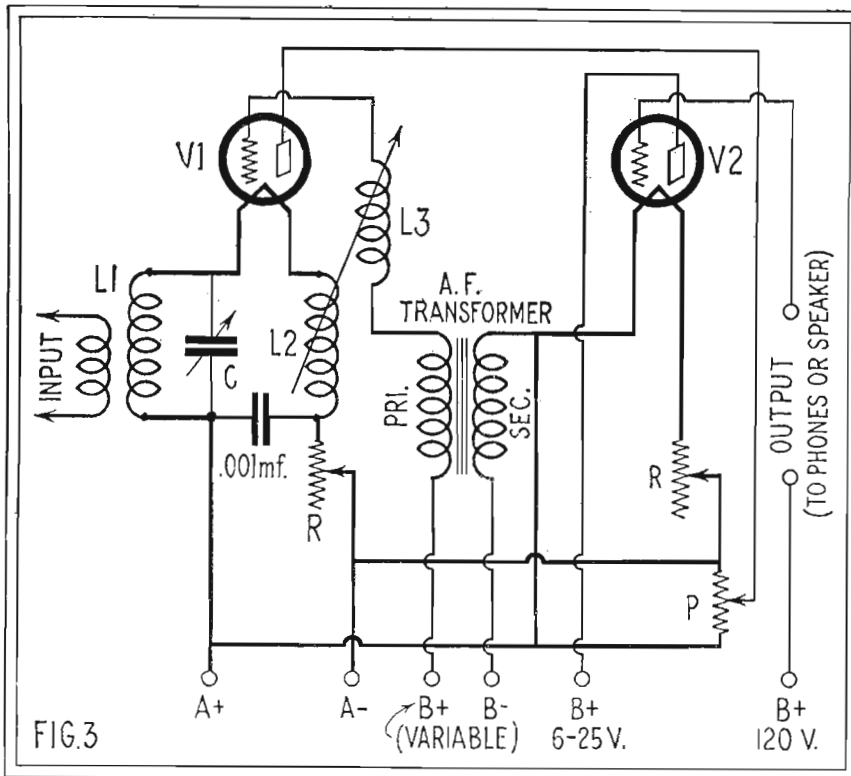

FIG. 3

This is the author's first application of the filament-input idea to an audio amplifier. It includes, however, the transformer with which he is endeavoring to do away, though good results were obtained.

at once be apparent; since the transformer secondary would then be directly shorted.

Fortunately however, the circuit of Fig. 3 functions very well indeed; far better than had been even remotely expected.

We are no nearer yet, however, to our conception of the perfect amplifier; since our new circuit still retains a coupling medium, in this instance, of the A.F. transformer.

Though a good transformer may introduce so little distortion that it would remain unnoticeable to even a critical ear, yet it seems a case of "tis folly to be wise;" for we may not rest content until real direct coupling is achieved.

Now it is the peculiarity of a filament-input detector circuit that output impulses are present, not only in the grid circuit, but also in the plate circuit. This fact may easily be verified by inserting a pair of headphones in the plate circuit, when it will be found that signals are but a little weaker than those obtainable in the grid output circuit. That the signals are slightly weaker may easily be explained by the additional resistance lowering the efficiency of the rectification bend; and curves may be drawn to prove this.

Hence we are provided with a second output electrode which has no high positive "B" potential. It must, however, have a small biasing potential with respect to the filament of the tube of which it forms part; and here it would seem that we are in a "blind alley" once again.

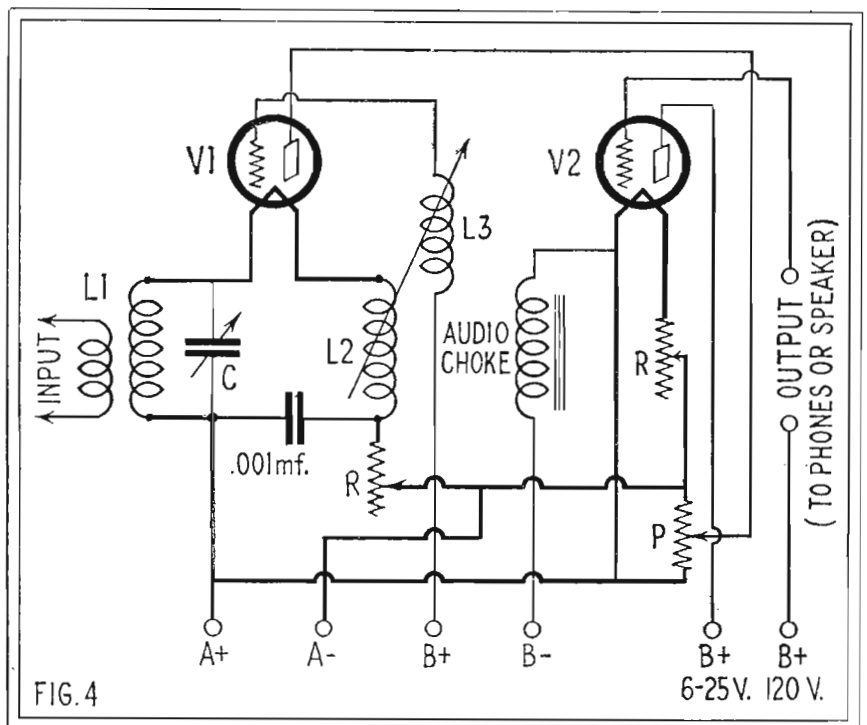

FIG. 4

This is the circuit which the author has arrived at, and which he suggests as a starting point for other experimenters who are not afraid to try the unconventional. Only approximate data are given.



An Amusing "Talking Doll" For the Children

An amusing "talking doll" can be made for the children by concealing a small telephone receiver or loud-speaker unit in the body of an old doll.

The body fabric in the back of the doll is slit open just enough to admit the phone unit. Enough excelsior or other body filling is removed to allow the unit to fit snugly inside. The cord is pushed through the back of the doll and the slit for the unit and cord is then sewed up again.

A loud-speaker unit of the adjustable

RADIO NEWS has received from readers so many letters and ballots requesting more "Wrinkles" that it has been decided to re-establish the department. A year's subscription to RADIO NEWS will be given in compensation for each accepted item. If the author of the wrinkle is already a subscriber, his subscription will be extended one year or he may accept a one year's subscription to Science and Invention or Amazing Stories, both published by the Experimenter Publishing Co.

holes, twist them together inside the tube, and solder them. When made in this manner, the splice will be hardly noticeable.

Figs. 3 and 4 present two views of a simple device for holding the wire taut while winding a coil. Run a rod through the reel on which the wire is wound and support this on two Xs formed by driving four nails in a board. Empty thread spools are then fastened with wood-screws in staggered positions on the board, as shown in Fig. 3. Now run the wire past the spools as illustrated. Different degrees of tension may be ob-

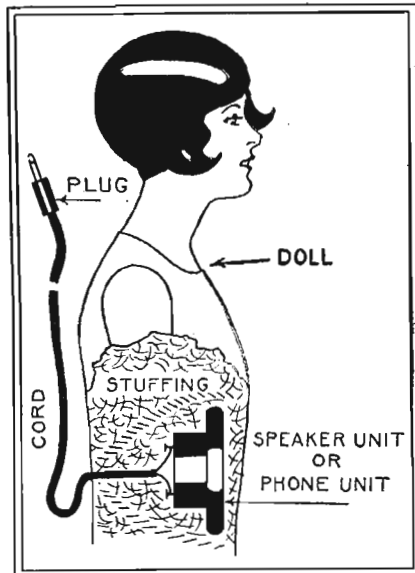

If the cord running to the speaker unit is concealed and the doll placed on a chair, the effect on the children is very amusing.

a panel equipped with luminous dials presents a strikingly novel appearance and at the same time provides a means of tuning the set in the dark.

A good grade of radium luminous compound should be procured and applied to the dials and markings on the panel of the set with a wooden or glass stylus. It should be forced into all graduations on the dials and other controls; with special care to wipe off all surplus compound, so that the markings will present a neat, clean-cut appearance in the light as well as in the dark.

It should be remembered that there are two classes of luminous compounds; one grade containing no radium salts is effective only for short periods after which it has to be renewed, while the other does contain radium salts and will retain its brightness for years. The latter is the grade that should be used.—Contributed by Dorothy Dietz.

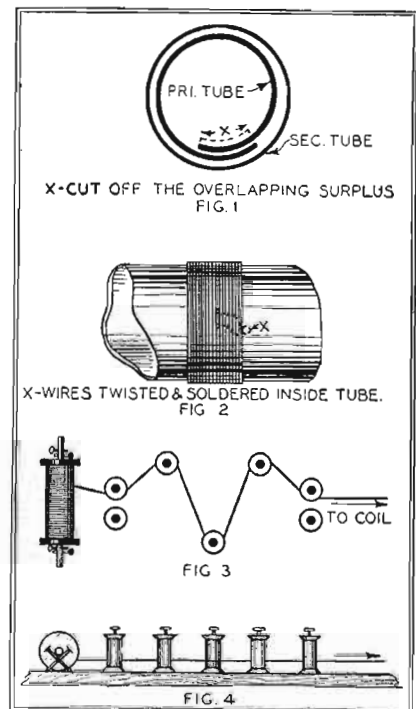

Fig. 1: Fitting a primary inside a secondary. Fig. 2: Making a joint that won't show. Figs. 3 and 4: Keeping wire taut while winding.

Some Useful Hints On Winding Your Own Coils

NO doubt, many home set builders have at some time had difficulty in procuring a primary tube form of the proper diameter for use inside a secondary tube. Fig. 1 illustrates a simple method of overcoming this problem. A short piece of tubing of the same diameter as that of the secondary tube is cut; and the edges are lapped until it is of the right diameter to slip inside the secondary. Then cut off the overlapping portion, which will run in the neighborhood of three-quarters of an inch. The edges are held together until the primary wire is wound in place, and then the wire will hold the tube firmly to the correct diameter.

There are times when, in order to be economical, it is necessary to make a splice in the wire while winding a coil. The usual splice always leaves an unsightly lump. To avoid this, drill two small holes at the point where the splice is to be made, as in Fig. 2. Run the ends of the wire through these

tained by placing the opposing spools at different distances from each other.

In winding coils with spaced windings, when a thread is used to space the turns, a similar tension may be placed on the thread. However, as there is no insulation to mar on the thread, as there is on the wire, staples may be used instead of spools.—Arthur L. Kaser.

type may be used, but in this case it should be properly adjusted before it is placed in the doll. A phone plug is placed at the end of the speaker cord and the plug is pushed into the loud-speaker jack of the receiving set.

This "talking doll" will afford amusement for the children, as it can be made to talk or sing at will by merely tuning in the desired station on the receiver. The speaker unit can also be placed inside of a toy dog, cat or other toy animal instead of a doll.—Contributed by H. R. Wallin.

Luminous Dials Make Tuning In the Dark Easier

RADIO listeners who use their receiving sets during the early evening or late at night, and who like to listen to the programs in a darkened room, will find that

Protecting the Work Table with a Window Shade

MY radio work table is in the corner of the kitchen, because of lack of space elsewhere, so my tools are too convenient for other members of the family. Besides, I have frequently been annoyed by finding

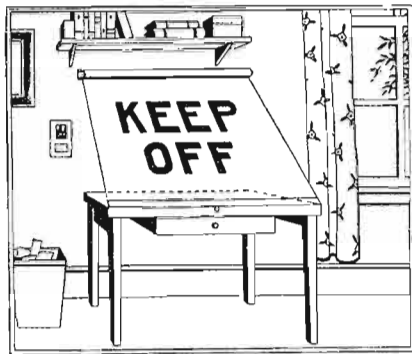

A window shade fixed in the position shown not only protects the table from dust but discourages the other members of the family from playing with your tools.

that my table was a catch-all for every kind of household article. To remedy this situation I fastened an old window shade to the wall above my work bench, and when I am through working I pull down the shade and attach it to a hook on the front of the table. Across the front of the shade I have printed in big letters "KEEP OFF." The result is that the family has taken the hint. Now I can pull the shade over the table and know that when I let it up again my tools and the things on the table will be just as I left them.—Contributed by Malcolm D. Jones, Jr.

Making Your Own Distilled Water For the Battery

It is sometimes difficult to obtain distilled water with which to refill storage "A" and "B" batteries. At such times the following plan may be used to produce the small quantity of water required to refill the batteries of any receiving set. A large thin-walled vessel, a kettle, and a large dinner (or soup) plate comprise the parts required. The cooling vessel should have a very thin wall, preferably of aluminum, and should be filled with cold water (ice water if possible) and suspended close to the spout of the kettle, the dinner plate being placed directly beneath the cooler. The kettle should be filled with water and this brought up to the boiling point; then the jet of steam from the spout should be adjusted to strike the outer wall of the cooling vessel. As the steam strikes the vessel it will be condensed and the distilled water will drip off into the plate. Despite its crudeness the device will be found to produce plenty of distilled water for refilling the batteries.—Contributed by C. A. Oldroyd



This simple "condenser" arrangement will supply pure distilled water at little cost.

A Cheap and Handy "Trouble Shooter" for the Experimenter

A HANDY trouble-shooter that will operate either on the house lighting circuit or on batteries is a useful addition to any radio work shop. A tester of this kind for use in tracing broken wires, short circuits, etc., can easily be made at home at a very reasonable cost. The mounting board should be 5 inches wide, 8 inches long and at least one-half inch thick. Seven binding posts are required, and should be mounted as shown in the accompanying diagram. The lamp socket should be wired in series with posts No. 2 and No. 5. Use a 110-volt lamp of not over 25 watts rating in this socket. Next, make up two five-foot portable cords and solder two 5-inch pieces of No. 8 copper wire to one end of them. Wooden handles may be slipped over the soldered splices for convenience in handling, and the

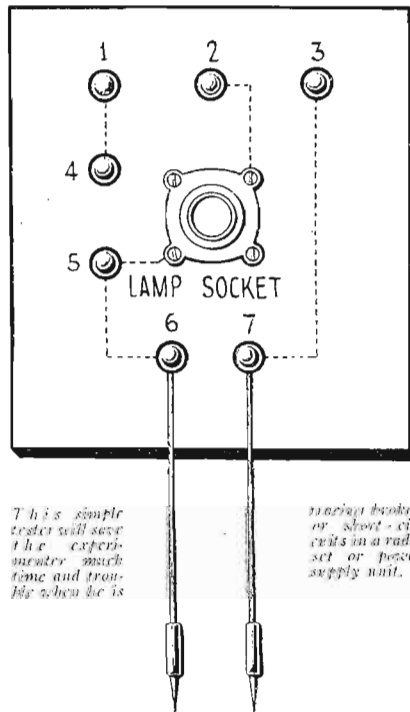

This simple tester will save the experimenter much time and trouble when he is tracing broken or short circuits in a radio set or power supply unit.

ends of the wire filed down to a sharp point. These cords are then connected to binding posts No. 6 and 7. A cord and attachment plug should next be made up of sufficient length to feed the tester from the light socket. These feeders connect to posts No. 2 and 3. When using battery current attach the feeders to No. 1 and 3 and connect a pair of headphones to posts No. 4 and 5. The battery and headphones will be found best for testing high-resistance coils in the set; while 110 volts and the 25-watt lamp may be used for tracing wiring, short-circuits, etc. Contributed by S. Saunders.

Low-Capacity Condenser Made From Large One

THE radio experimenter frequently has need of a low-capacity variable condenser. As there are often any number of large-size condensers laying around the radio work shop, a method was found of cut-

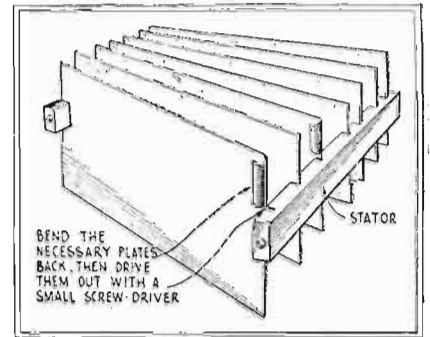

A good low-capacity condenser can be made by driving out every other plate of a large-size instrument.

ting down the capacity value of these condensers to meet the requirements for a small-size condenser. If none of these large condensers is on hand, they can usually be obtained for a small sum. By purchasing these large condensers and removing some of the plates or double-spacing them for the proper values, a good low-capacity condenser can be obtained at small cost. In some condensers the extra plates may be removed by bending them back so that they can be driven out with a small screw driver, as shown in the illustration. In other types, the plates can be removed by using a pair of long-nose pliers and bending the plates until they break off at the supports. The rough edges may be smoothed off with a small file. After removing part of the plates in the condenser, it is usually necessary to re-adjust the lock-nuts on the end plates so that the rotor plates pass in the center of the stator plates. If desired, the condenser can also be triple spaced by removing two plates at a time instead of one. In this case the capacity is decreased considerably. Such condensers can be used to advantage in amateur transmitting sets.—Contributed by Clyde A. Randon.

A Handy Connector Plug For the Dynamic Speaker

THE new electrodynamic speakers require four wires for connections. The six-volt type seems to be the favorite and as I am engaged in radio service work I am frequently required to wire the receiving set so that the speaker can be (Continued on page 358)

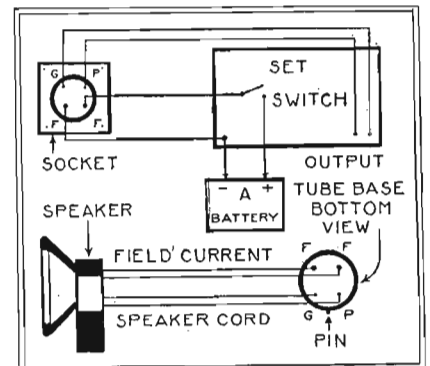

This diagram shows how an old tube base may be converted into a convenient connector plug for a dynamic speaker.

Radiotics

WHAT AN APPETITE!



Testimonial letter in *New Zealand Radio*: "We now have 2LO - SSW (England) ON THE LOUD SPEAKER FOR BREAKFAST." With honeydew melon, bacon and eggs, dry toast, a side order of hashed brown potatoes and some black coffee to wash down the taste of the insulation, we presume.
—Edmund Hawthorne.

THIS PEAKS EVERYTHING

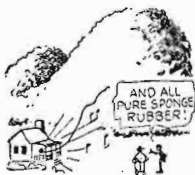

More useful advice, this time from the *St. Louis Post Dispatch* of July 1: "When the elements of a tube are not firmly held in place it becomes microphonic. This condition is due to vibration. The noises can be prevented by sponge rubber MOUNTAINS, anti-howler caps and other precautions." How about a hammer?
—J. W. Hittle.

GOOD MANUAL CONTROL, WOT?



Advertisement in the radio section of the *New York Sun* of July 14: "Sets Built to Order. HANDPASS FILTERS, Matched Intermediates, Muller, 117 E. 19th Street." This must be one of those "music from the air" outfits that are tuned by waving the hands in front of them.
—R. Montague.

HOW SHOCKING!

Technical description in the *Detroit News* of July 22: "Merle Lanphere, a Wenatchee radio engineer, wrote to Mr. Redfern that the apparatus steps up 220 A.C. to 25,000 volts. He described it as simply a large spark transmitter using an OSCULATING circuit." How would you like to be kissed by 25,000 volts?
—H. M. G. Mortimer.



BUT PUMP 'EM UP FIRST

Our esteemed contemporary, *Popular Radio Weekly* (Australia) has the following caption beneath a picture: "Using 222 TYRE tubes in an audio amplifier." We suppose that, if the tubes blow out, they can be repaired with those gummed patches and a match.
—Herndon Given.



RIDE 'EM, COWBOY!

The wild and woolly West is doing its damndest even in these advanced days of broadcasting. The *Sioux City Journal* of July 24 says: "One hundred and fifty head of cattle stampeded through the streets here to-day following the wreck of a freight train. The police and motorists staged many impromptu RADIOS in the downtown district."
—F. D. Carpenter.



WHAT AN OUTFIT!



Bargain sale advertised in the *Worcester (Mass.) Gazette* of July 24: "Clearance sale radios, 36-TUBE table models, \$14.50." If they'd throw in the local power house and a few spare tubes, this would make a nice set to have around the house at Christmas time.
—David G. Rabinowitz.

If you happen to see any humorous misprints in the press we shall be glad to have you clip them out and send to us. No **RADIOTIC** will be accepted unless the printed original giving the name of the newspaper or magazine is submitted, with date and page on which it appeared. We will pay \$1.00 for each **RADIOTIC** accepted and printed here. A few humorous lines from each correspondent should accompany each **RADIOTIC**. The most humorous ones will be printed. Address all **RADIOTICS** to

Editor, **RADIOTIC DEPARTMENT**,
c/o Radio News.

A NEW ONE ON ARMSTRONG

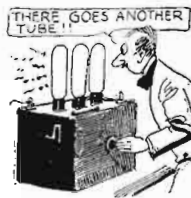

All radio fans who have had dead batteries on their hands should answer this advertisement in the *New York Sun* of June 23: "For Sale, three-tube REGENERATIVE BATTERY. Complete, \$15." The only danger is that, if you advance the regeneration knob too far, the battery is likely to spoil the carpets.
—Hyman Herman.

SERVE IT ON THE PLATE

Tempting offer in the *Springfield (Mass.) News* of July 17: "For sale, motorcycle and radio CHOP at 335 Orange Street." As a housekeeper I am always looking for something new in the eating line. This radio chop sounds appetizing; should I fry it on the "grid?"
—Mrs. S. E. Lofgren.



HORSES, HORSES, HORSES!

New use for colts revealed by the *New York Sun* of July 15: "It is preferable to make this adjustment with the aid of an A.C. COLTMETER connected across the heater terminals of the tube." With their place in radio established, its trend will undoubtedly be toward better accommodations for our barnyard friends.
—Charles Christman.



A SELF-CLEANING SET

Allen-Rogers' catalog lists "plug-in short wave INDUSTORS" for use with .00014-mf. tuning condensers. Many a house wife would appreciate a set of these coils, because they would save her some work every morning. Or perhaps they dust off the static and make the reception nice and clean.
—Peter Smith.



IN HOT WEATHER, YES

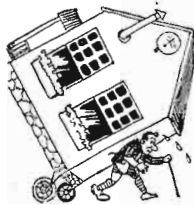

Practical wrinkle published by the *Cincinnati Enquirer* of July 22: "A satisfactory set inexpensive - low-range voltmeter may be made with a low-reading milliammeter and a variable RESISTENCE." It would be rather inconvenient to carry such a meter around though, wouldn't it?
—R. Bucher.

OH, DEARIE!



Perfumed advertisement in June *QST*: "For use in amateur transmitters and medium POWERED commercial installations, the regular line of Cardwell condensers has no peer." What with television coming, the broadcast stations will be hiring cosmeticians to see that the make-up of the studios is OK before the cameras start working.
—Leon B. Stroik.

NOT WITH PLUG-IN COILS!

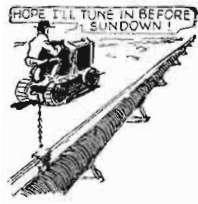

Under the headline "Radio Amateurs Hear Distress Call From Ship," the *Crawfordsville (Ind.) Review* says "the amateurs received the messages on wavelengths varying from 800 TO 1,000 MILES." Looks as if the old days of the stovepipe tuning coils were here again. We hope the wavelengths didn't vary too much; imagine a poor operator climbing up a 1,000-mile inductor and adjusting its turns!
—J. C. Markin.

HOT STUFF!

Classified advertisement in the *McKeesport (Pa.) News* of July 21: "For sale, TEN TUBE Radiant fire reliable gas range, white kitchen cabinet. What a boon this would be to the young bride who follows the radio cooking lessons every morning!"
—Mike Plutko.



AN HONEST MAN AT LAST!

Startling headline in the *Grand Rapids Press* of June 29: "He Resides in a TUBE. Just as Did Diogenes." To unscramble this piece of history, we might say that the Greek cynic lived in a tub and used an oil lantern in his search, but that was before the days of radio.
—John Kanulaukas.

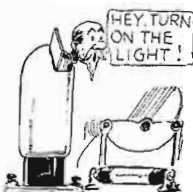

NOT ALL OF IT

Explanation of these wise-cracking lectures that we get an occasional earful of, in the *New York Herald Tribune* of July 22: "The Quantum theory is that energy is radiated in DISCREET particles." Let's tune old Quantum out and see if we can catch Paul White-man on the air.
—S. H. Woods.





On the Short Waves



2XAL'S Schedule

ALL programs of the RADIO NEWS station WRNY are transmitted also simultaneously through station 2XAL on 30.91 meters (9,700 kilocycles). This will apply also to the television broadcasts, the schedule of which will be definitely given later.

Outside a radius of about 200 miles, this station has been heard very clearly by short-wave listeners in most states and in Canada. Regular reports are received also from Europe, the northern part of South America, Hawaii, Australia, India and South Africa.

We shall welcome and verify reports of reception from all quarters. The hours of operation are as follows:

7 to 9 a.m., Eastern Daylight Time, or 1100 to 1300 G. M. T., every day.
 11 a.m. to 1 p.m., E. D. T., or 1500 to 1700 G. M. T., daily except Sunday, when the program ends 30 minutes earlier.
 2 to 7 p.m., E. D. T., or 1800 to 2300 G. M. T., Mondays, Wednesdays and Fridays. On Sundays, 1:30 to 6:30 p.m., E. D. T., or 1730 to 2230 G. M. T.
 After 7 p.m., E. D. T., or 2300 G. M. T., on Tuesdays until midnight (0400 G. M. T., Wednesday); on Wednesdays till 9 p.m. (0100 G. M. T., Thursday); on Fridays until 11 p.m. (0300 G. M. T., Saturday); on Saturdays until 10 p.m. (0200 G. M. T., Sunday).

On September 30th next, New York local time reverts to Eastern Standard Time, five hours slower than G. M. T., instead of four as shown.

COMMERCIAL USE OF SHORT WAVES

Editor, RADIO NEWS:

I congratulate you on your wise decision to set aside a special section in RADIO NEWS for comments on short waves. The future of radio is skillfully enclosed by Nature within the high-frequency waves and it remains for men of science devoted to this study to open up the way by continued experimentation and study of the high frequencies. When this is done international brotherhood will be a real tangible fact.

In the meantime, do the various Chambers of Commerce in the numerous sections of the United States realize the tremendous power behind short waves to open up the markets for American products in Central and South America? Please notice what Holland, through PCJJ, is doing in sending direct and indirect advertisements to Cuba, Argentine, Brazil, Venezuela and Mexico, to sell what they make on the other side of the Atlantic Ocean. Short-wave transmissions could do more for the good will of North and South America than all of the Pan-American Conventions, and be just as effective as the great flight of the young American aviator to Mexico as good-will ambassador.

I do not make any further comments on this matter, but simply would like to open the eyes of stations other than KDKA, WGY, WLW, WRNY and WABC, which are transmitting regularly on the short waves, to go ahead and aid in the building of this great international brotherhood.

R. DEL VALLE SARRAGA,
 Vice-President, Radio Club of Puerto Rico,
 Box 935, San Juan, P. R.

AN OPERATING HINT

Editor, RADIO NEWS:

Anyone wishing to improve the operation of his short-wave receiving set should install another aerial. I now have two aeriels and connect one to the plate coil and the other to the grid coil of my short-wave set. I never use headphones any more and I receive KDKA on 66 meters loud enough to be understood all over a seven-room house, in addition to hearing amateur stations from all parts of the United States and Canada.

CARL W. PEADRO,
 Gays, Ill.

JAPANESE PROGRAMS

Editor, RADIO NEWS:

The regular broadcasting schedule of station JOAK, Japan, on short waves, each month, is as follows:

Date	15	16	17	18	19	20	21	22
Wavelength (meters)	30	60	35	70	30	60	35	70

I hear this station and others often. JOAK is quite easily received on the Pacific Coast during the fall, winter and spring months, when atmospheric conditions are clear. I find, after several years of specializing in long distance, that the most favorable atmospheric condition is when the stars are shining the brightest, it being practically impossible to hear extreme distance during a haze or heavy cloudiness, or particularly a fog, the occasional exception being immediately before, during or after a rain, when fair reception is possible.

The above information is correct and the station schedule authentic.

L. J. WRIGHT,
 3068 Casador Street, Los Angeles, Calif.



The short-wave transmitter of 2XAL is small and simple, but carries farther than high-power stations on long waves.

TELEVISION ON 62.5 METERS

Editor, RADIO NEWS:

You will be interested to know that station WLEX has been granted a temporary three-months license to broadcast experimental television signals on a wavelength of 62.5 meters and to make use of a frequency band 200 kilocycles wide. This is going to permit this station a large latitude in experimental work and we are expecting some excellent results from these tests. The signals of this station have been received by amateurs in and around this vicinity with very good success. Just at present the station is handicapped by a weak power transmitter, but work is being done to increase the power.

Station WCFB, using a forty-five hole disc, is soon to be on the air in Chicago. Their wavelength, the last I heard, was to be 195 meters. Fairly successful reception of pictures has been possible from this station by airplane.

D. F. REPLOEGE,
 Raytheon Manufacturing Co.,
 Cambridge, Mass.

EUROPEAN TRANSMISSIONS

Editor, RADIO NEWS:

Just a few short-wave notes from an English short-wave enthusiast which may be of some use to you.

The Eiffel Tower, Paris, is conducting various short-wave tests on about 32 meters. Call PL. No fixed schedule. Very strong signal here. Your correspondent Alvin Carlson, of Gladstone, Mich., says 5SW (London) closes with twelve strokes of gong, of course, this is the Big Ben clock, London. Also, 5SW does not transmit on Saturdays.

I can clear the point about PCJJ. G. W. Robinson of Buffalo says PCJJ is at Eindhoven (Holland) and you say it is at Hilversum. The actual transmitter is at Hilversum but the control studio is at Eindhoven, so it is always announced as Eindhoven. Announcements from PCJJ are generally made in Dutch, English, German and French.

The English wireless magazine "Radio World" says there is a Spanish station at Madrid on 30.7 meters. Call EAM. Perhaps this will help your correspondent, Robert M. Sprague, of Hanover, New Hampshire. Bandoeng seems to be pronounced by the Dutch as "Bandoeng"; perhaps this will help F. W. Fitzpatrick of St. Johns, Mich. As to his word "Bostol": PCJJ is sometimes heard calling up Java as "Allo, radio Dienst-Bandoeng."

I hope that the above information may be of some use to you, even if it is a bit late (RADIO NEWS does not arrive here until about the tenth of each month). I think RADIO NEWS is a fine

(Continued on page 392)

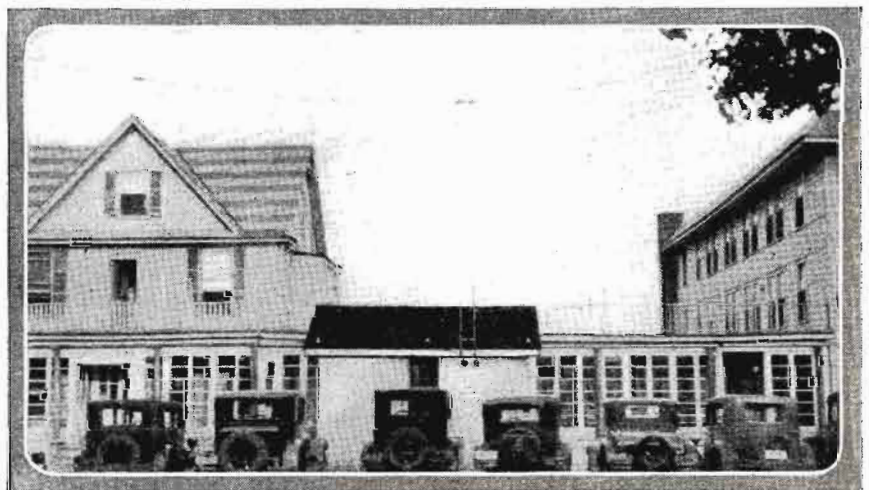

The transmitter house of WRNY and 2XAL at Villa Richard, Coxsackville, N. J., opposite 181st St., New York City. The larger aerial is above the pictured scene; that of 2XAL, a Hertzian doubler, and in line with it in the counterpoise, another L, and the R.F. leads separated by insulators, may be seen.

Main broadcast call table with columns for Radio Call Letters, Broadcast Sta. Location, Wave (Meters), Power (Watts), and a second set of columns for another set of stations.

LIST OF CANADIAN BROADCAST CALLS

Table listing Canadian broadcast calls with columns for call letters, location, wave, and power.

LIST OF SHORT-WAVE STATIONS OF THE WORLD

Large table listing short-wave stations worldwide, categorized by continent (Africa, Australia, Canada, Denmark, England, France, Germany, Italy, Japan, Java, Holland, U.S.S.R., U.S.S.R. Far East, Sweden, Switzerland, United States) and including a detailed text box about the list's purpose.

(Continued on page 391)

The Radio Constructor's Own Pages

Wherein Custom and Home Set Builders and Experimenters
All Over the World Swap Experiences and Suggestions About
Hookups and Accessories



IN DEFENCE OF THE 4-TUBER

Editor, RADIO NEWS:

I have just run over the magazine for this month; I can hardly wait till they come out. I have played with radio for five years, and have built many good sets from your articles, for instance the Interflex and the Regenerative Interflex, also the Peridyne. Though I do not favor one-dial sets, this comes nearest to the mark of any I have had experience with.

On account of illness, in the last three years I have done nothing but build sets for my friends; and there are several of them I have rebuilt to later models, to include the nice big audio transformers now on the market, power tubes, S.L.F. and M.L.F. condensers and smaller coils. In this length of time I have built not less than 75 sets; all with good parts or I do not build them.

In regard to your newer policy, which I think is a good one, the Neutroheterodyne described in the May and June issues will hit many a fan just right. I am especially interested in this hook-up. I would the intermediate coils for the L2 Ultradyne described in your May and June 1926 issues and, although the transformers were not matched, I could pull any station in the United States with this hook-up, which I still think is hard to beat. I also built the Stroboddyne; some kick in this set! I listened to Japanese stations such as JOAK and JOCK, also Cuban stations. (No, I did not get Australia.)

In this June issue, I ran across Mr. Maxwell Hamilton's little speech; now let me add mine. Mr. Hamilton, residing over 100 miles from a superstation, says he tied the can on his Browning-Drake and is using a 5-tube Neutrodyne. In defence of the 4-tube variety, nothing short of a 7- or 8-tube shielded neutrodyne or superheterodyne could be considered in my location, three miles from KF1 and ten miles from about fifteen or twenty other lesser stations. The 4-tube set, such as that mentioned, and many others of similar power come nearer separating the high-frequency stations than any sets I have had experience with, and, as for quality: I have one of these four-tubers for local purposes, with two good audio transformers and a 210 tube using 350 to 425 volts on the plate, a well-known cone speaker and an overstuffed chair with an amber light; and I am listening at 10:00 p. m. to the dance orchestra at the Coconut Grove, Ambassador Hotel. It does not sound bad, either; I have heard worse.

Back to Mr. Hamilton: I have rebuilt these so-called five-tubers (not ancient ones either) into four-tubers. With these five-tubers, when you get down below 275 meters, you would think they were holding a convention.

FRANK E. EKSTROM,
636 West 79th St., Los Angeles, California.

ALL FOR THE BETTER

Editor, RADIO NEWS:

Let me congratulate you on the improvement in RADIO NEWS since the change of policy! Now one really enjoys sitting down reading the magazine. Every article has a story to tell and advertising has been forced into the background. No

wonder your readers like the change. I don't think the other radio magazines will have the courage to follow your example. But then, you have always struck out along original lines, and that is the feature which makes your publications so attractive.

The manufacturers will perhaps object to a "clean" magazine devoted entirely to the interest of the enthusiastic experimenter, and devoid of disguised publicity; but the time will come when they will admit your change was all for the better. After all, a radio magazine must first of all stimulate the interest in radio. If this is skillfully done, the producers will soon feel the effect. More power to your elbow!

C. A. OLDROYD,
Barroco-in-Furness, England.

SUGGESTED NEW TUBE

Editor, RADIO NEWS:

I wish to call your attention to an idea for a new tube, though I have no way of making one at present. It would be built to displace the space-charge by repulsion, rather than attraction; as is the case with the screen-grid tube when used this way. It would have one grid, one filament and two plates; the center element being a small, narrow plate with the filament extending up one side and down the other, as close to it as possible without danger of a short circuit. The rest of the tube is arranged as in a 301A. The small plate in the center is charged negatively, say 45 volts, and will repulse the electrons of the space charge from the center of the tube. Being out of the path of the electronic flow, it would do away with any absorption or feeding back from through the batteries. While not as good as the screen grid at radio frequency, I think this would be much better as a space-charge displacer in audio and other places where a tube of this kind can be used to advantage. If you think this a good idea and should make a tube like this, please let me know what results you have with it.

WILLIAM J. HOWARD,

703 Chamberlain St., Corpus Christi, Texas.
(The idea is ingenious; but the mechanical difficulty of constructing a filament with a plate inside of it is rather too great, as the filament would screen the plate physically and electrically. Many of our readers suggest the construction of new apparatus on a purely theoretical basis; we are unable to undertake development work of this kind, but we and our readers are always glad to learn what has been done. The inventor who has conceived a new idea and publishes it is protected for a period of two years in getting out a United States patent; it is necessary, of course, that he shall thereafter use due diligence in perfecting its details.—EDITOR.)

USE AND ORNAMENT

Editor, RADIO NEWS:

The speaker illustrated here is of the balanced diaphragm type on a frame 36 inches square, covered with tracing cloth treated with collodion. The rear diaphragm is 9 inches square. It is covered with a hand-painted sunset scene in colors which, of course, do not show. This serves as a screen for the fireplace as well as an excellent reproducer. The frame, legs, and carrying bundle are finished in walnut with an edging of tinsel fringe around the painting.

WM. I. VAN ARNUM,
Youngstown, Ohio.

Mr. Van Arnum's solution of the three-foot speaker problem is shown at the left. Of course, some artistic ability is required for this.

BLUEPRINTS ARE POPULAR

Editor, RADIO NEWS:

Please mail set of blueprints for the "Neutroheterodyne," published in the June issue of RADIO NEWS.

I like your home construction articles very much, on account of the fact that I enjoy making the coils, etc.; also because of the fact that many of us have quite a number of old parts on hand which can be used in connection with a circuit of this kind, whereas, there have been so many articles of late regarding A.C. tubes, circuits, etc., which require the purchase of entirely new parts, that it leaves us with some very good old parts on hand for which we can find no use.

W. B. HUNKINS,
Box 655, Hollywood, Calif.

Editor, RADIO NEWS:

Please send me your Blueprint No. 56 as described in the June issue.

I have been a reader of RADIO NEWS for about two and a half years and have derived much pleasure and real knowledge from its pages. I think your recent policy has much to commend it, since I believe most of the readers look for information which will be of value to them in pursuing the elusive radio "bugs."

Thanking you for the blueprint articles and wishing you every success,

LEO DEWSEN,

1118 June Street, Wilkesburg, Penna.
(Over ten thousand free blueprints have been mailed to inquirers to date, and the requests are increasing. These cannot be sent with the magazines, as numerous subscribers request, because of U. S. postal regulations.)

FAR FROM THE FACTORY

Editor, RADIO NEWS:

I feel I must write to let you know the opinion of one of your overseas subscribers. If reverting to the old policy means the reintroduction of giving data of coilage, then I think it is more than justified. We in Australia are not in a position to purchase kits until at least twelve months after the circuit appears in RADIO NEWS, and in some cases not at all. So you can see that in R.F. circuits, we cannot try out the various coils owing to the lack of information. The same trouble exists in relation to oscillator couplers; having an intermediate and transformer kit, but no coupler, I cannot try out the various circuits unless the number of turns, gauge of wire, etc., are given. I have made several oscillator couplers for various circuits, but cannot just strike the right thing.

When you first published the Infradyne circuit, I imported the Remler amplifier and condenser, etc.; but it was over twelve months before the amplifier was on sale here and then, unless you possessed a copy of RADIO NEWS or the Infradyne manual, the thing was useless; as no special oscillator was brought out with it. And the price asked for the amplifier alone! Sixty dollars.

The kit system is O. K. for the man who wants to make a set and leave it; but for one who is continually experimenting with each new circuit it is useless, unless of course he has money laid on. One firm out here is making up the Peridyne coils; they retail at about \$15.

Tube prices have dropped this last week, the following giving you some idea of the now prevailing retail prices: UX-199, \$2.40; UX-201A, \$1.92; UX-171, \$5.04. The first shipment of screen-grid tubes has been put on the market, being the English Osram 6-volt 625, retailing at \$7.23. The prices are mentioned only for comparative purposes and to show the difficulties under which we suffer in regard to kits.

The local "B" class station 2GB announced recently that they will be on the air on the short wavelength soon, probably on dual wavelengths.

The Commonwealth Government collects our listener's license fee, \$4.97 per annum, and as the enclosed clipping shows, is at last doing something to co-ordinate the programs.

Assuring you of my continued support to RADIO NEWS.

ALBERT JIARIS.

14 Ranger Road, Croydon, New South Wales, Aus.



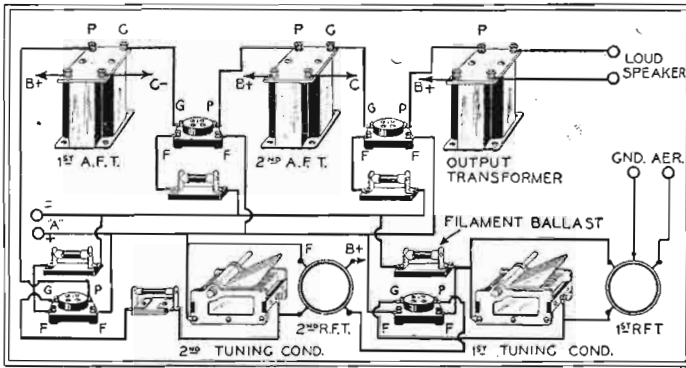

PRINCIPLES OF SET LAYOUT

Editor, RADIO NEWS:

This is a plea for simplicity. In presenting it, I have in mind my own first attempt to follow a pictorial wiring diagram—and the howls and “echoing silence” which ensued until I doped out the schematic. That set was of the “super-hyper-dyne” variety and unquestionably was a “howling success.”

Gone are the old-time regenerators and the ungrounded rotor and the lead-pencil vernier. Gone, too, are the two-pound condensers and the variometers which reached half way across mother’s biscuit board. Every Tom has made his “Worse-World” circuit out of the old ones; every Dick has juggled the parts for it; and every Hank has put its old gadgets in new cases. But still we build IT and all the other “its” from left to right, leave the most important leads as long as convenient and place by-pass condensers across audio stages to quiet them down.

Now that A.C. filament supply has come into vogue, we add insults to our injuries to “Dame Electra,” insert a “twisted pair” and heap epithets of opprobrium upon the more or less reputable tube-maker who promised little or no 60-cycle hum!

Instead of having another parts-juggling spasm like that which accompanied the first wave of enthusiasm or T.R.F. receivers, why not look for a different route from “Hamtown” to “Musical,” and, while we are about it, try to find one both shorter and more substantial than the old.

My own receiver layout is shown in the accompanying diagram. It roughly illustrates an average layout for an average set, capable of running circles around similar average left-to-right layouts, all-around performance considered. Only sufficient detail is shown to illustrate the principle involved and none but essential parts are included; but it will be noted that ample room is allowed for the latter.

Briefly, the following features will be noted:

- (a) Short leads in all circuits carrying R.F. current, especially oscillating portions thereof;
- (b) Short A.F. grid and plate leads (yes, it helps);
- (c) Wide separation of successive stages and portions thereof; R.F. entirely removed from A.F. grid and plate leads;
- (d) Filament leads well removed from sensitive portions of circuit;
- (e) Well-adapted for cable wiring;

One truism which has been much overworked in the past is, “Grid leads should be ultra-short, plate leads as short as convenient, and the two well-separated, but battery leads are immaterial.” The net result has been that the uninitiated consider a connection a battery lead from the point it leaves the inductor and frequently place it parallel to another similar lead or even a grid or plate connection. Then, without looking the “job” over, we call it “battery coupling” and advise better by-passing, which may help and may not. Would it not be simpler to advise separation of such leads and by-passing direct from inductor to tube? The right-to-left layout allows plenty of room.

This letter is in no way a criticism of RADIO NEWS circuits, (barring the now defunct manufacturers’ outfits which have already received enough lambasting). Neither is it something new—although it is far more up-to-date than many much-touted “dud-dynes” of recent years—and the writer certainly has nothing to sell in the way of advice or circuits. . . . He always has too little time for experimentation and is still able to learn, which seems true of the entire radio fraternity with the exception of those who design the latest hits in setdom.

The layout as illustrated is but average and necessarily typical of a four-tube outfit. Add stages if you wish, either before or after the detector;

introduce body capacity for Heaven’s sake either reduce or buy some shields.

W. H. P. PERDUE,
Staff Sergeant, U. S. Army,
Sixth Corps Area, Chicago.

NEW POLICY A WOW

Editor, RADIO NEWS:

Many times I have been on the verge of writing and have even gone so far a few times as to start and once finished one but never sent it. And now here it is along with a request for a blueprint. I have been reading RADIO NEWS for a stack about three feet high. Have at times been in sympathy and other times in a state of “Dempsey Admirers” argumentative.

Think the new policy will be a wow (Not Omaha). For instance; the application for the blueprint, accompanying. I have built many, same type at times and all have acted differently. Think a blueprint with the results of scientific calculation, etc., should be of big assistance; though of course we all will, like the musician who improvises, try and improve on the composer.

I have found that most of the time, under the old policy, we started a set and naturally being short of jack had to substitute in lots of cases and a good lot of the time it took a lot of trying, guessing and cussing before we made the bloomin’ contraption either oscillate or quit oscillating, whichever we did not want it to do. Under this new arrangement we ought to substitute with a working knowledge as to what to do when the thing acts up and our correspondence with other bugs will let up considerably. I have had lots of letters from different men on different hook-ups and the trouble usually comes from insufficient directions, mainly in constructional data, and usually my queries to them were of the same sort, when the trouble had simmered down to bedrock.

Would like to hear from some guy who has had some experience with double-grid tubes, particularly being used as an R.F. tube with a regenerative detector. Can’t help but think the above (two stages with one audio of about a 171 power tube) ought to work right nicely. Somebody please try it and let me know, as the kids need shoes and I am afraid the Mrs. won’t let me eat if I invest and it don’t work.

E. L. ROGGEV,
Waco, Nebr.

A STROBODYNE CONVERT

Editor, RADIO NEWS:

When Laocott came out with the translation of Lucien Christien’s Strobodyne method of reception, I read and reread the articles; but under no circumstance could I get the desired kick from the claims as made for the circuit or method used in detection, I want to say that I went so far as to build the oscillator unit, but never could raise courage enough to rig it up and try the scheme; having tried so many autodyne methods in my experience and finding them wanting in some respect.

Two or three days ago I didn’t have anything to do and was rummaging through the junk box and found the coil as I left it six months ago. A happy thought came to me that I might find out something if I would try the circuit out. I rigged it up from memory and hooked it onto the big super—and I want you to know that I have never found anything to give me the surprise of my life, during my experience in radio, that this one tube did (excepting of course to the Armstrong super-regenerator.) This tube, acting as it did, gave me the impression that it was really some kind of a super-regenerative combination rigged up to heterodyne through the intermediate branch of the circuit.

Well, further to back up the statement, I have five intermediates in the set. I was using the old standard super as it was found to be better than the autodyne methods which I have tried, and on many of the stations I could get them, but not satisfactorily. Now, since the change, I get all those stations with plenty of power and plenty of margin; and stations I could not separate at all. I now get with very good decency in selectivity. I am using a center-tapped loop at first trial and am figuring on using the tuned radio stage; but can’t figure out from further doping on the circuit just what the winding ratio is for the three windings; as this is a better method than using a tapped input coil.

For those wanting a kick I would suggest that they try it out and they will be more than surprised with results, provided they use a bit of care in parts used.

Yours truly,

S. W. NEWLAN,
Chief Testboard Man, A. T. & T. Co.,
Long Lines Dept., Key West, Florida.

DUAL AERIAL WIRES

Editor, RADIO NEWS:

Some months ago I wrote concerning distance reception and the number of stations that I had logged. May I say that, to date, I have logged and have verifications from no less than 469 stations. The longest distance received on this continent by me is 3,030 miles, station KFCU, 100 watts, at Holy City, Calif. I have picked up about forty amateur stations, and J.L.O., Melbourne, Australia, 32 meters, on a Sunday evening, about 5 p. m., on which I am awaiting verification. The receivers I have used are a C.G.E. Radiola 193 and a three-tube set built by my son, a lad of 17. He has built a number of sets which are giving good satisfaction in the district.

I think that one of the reasons for this success is the antenna that I have; my aerial, or aerials, is 100 feet long, with twin wires 30 inches apart; one cut at 60 feet has a separate lead-in; the longer can be

(Continued on page 388)

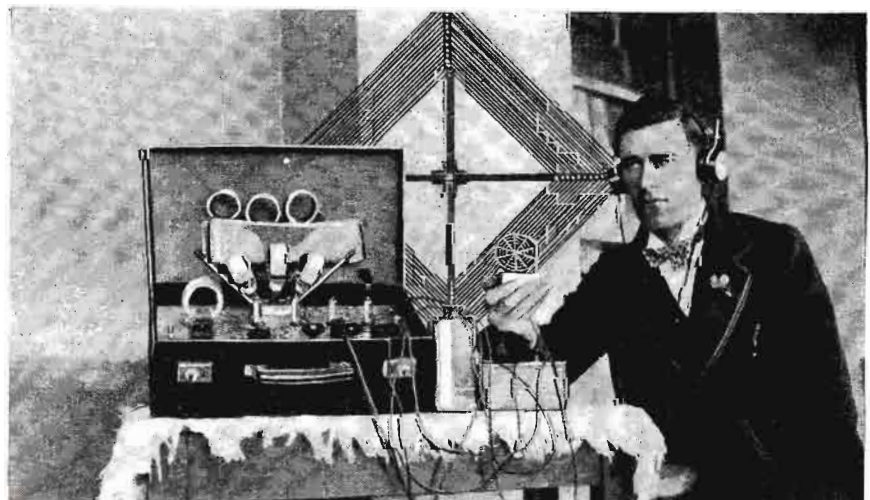

Mr. Stephens and his DX-getting “portable” at Hobart, Tasmania. The loud speaker in his hand is especially portable.



Radio News Laboratories

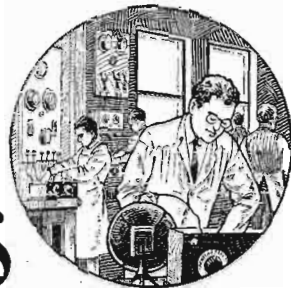

RADIO manufacturers are invited to send to RADIO NEWS LABORATORIES samples of their products for test. It does not matter whether or not they advertise in RADIO NEWS, the RADIO NEWS LABORATORIES being an independent organization, with the improvement of radio apparatus as its aim. If, after being tested, the instruments submitted prove to be built according to modern radio engineering practice, they will each be awarded a certificate of merit; and that apparatus which embodies novel, as well as meritorious features in design and operation, will be described in this department, or in the "What New in Radio" department, as its news value and general interest for our readers shall deserve. If the apparatus does not pass the Laboratory tests, it will be returned to the manufacturer with suggestions for improve-

ments. No "write-ups" sent by manufacturers are published in these pages, and only apparatus which has been tested in the Laboratories and found of good mechanical and electrical construction is given a certificate. As the service of the RADIO NEWS LABORATORIES is free to all manufacturers, whether they are advertisers or not, it is necessary that all goods to be tested be forwarded prepaid, otherwise they cannot be accepted. Apparatus ready for, or already on, the market will be tested for manufacturers free of charge. Apparatus in process of development will be tested at a charge of \$2.00 per hour required to do the work. Address all communications and all parcels to RADIO NEWS LABORATORIES, 250 Fifth Avenue, New York City. Readers will be informed on request if any article has been issued a Certificate of Merit.

SHORT-WAVE COIL KIT

The short-wave coil kit shown, submitted by the Air-King Products Company, 222-226 Grand Street, Brooklyn, N. Y., enables the amateur and short-wave bands of from 15 to 133 meters to be received by the use of three interchangeable coils (No. 1, 15 to 33 meters; No. 2, 31 to 68 meters; No. 3, 57 to 133 meters approximately) when tuned by a variable condenser of .00014-mf. (7-plate) capacity. Each coil has the wavelength range engraved on its frame. The coil forms, of skeleton low-loss construction, are very sturdy and rugged. The primary coil is variable and mounted by a hinged joint to the plug-in base mounting.

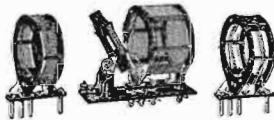

AWARDED THE RADIO NEWS LABORATORIES CERTIFICATE OF MERIT NO. 2393.

ELECTRODYNAMIC SPEAKER

The speaker (type D-44-A.C. shown) submitted by the Jensen Radio Manufacturing Company, Oakland, Calif., is of the electrodynamic moving-coil type. Its field winding is of the low-voltage type, and has a resistance of 15 ohms; the necessary direct current is obtained from the A.C. line through a step-down transformer and a rectifier of the dry metallic type. The cone, approximately 8 inches in diameter, is anchored to the speaker frame by thin kid-skin strips, cemented around the edge of the paper cone. The complete speaker is housed in a

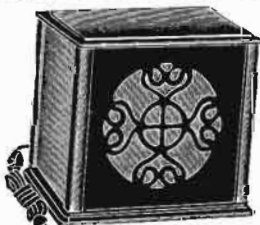

cabinet of pleasing design, which serves also as a baffle for the low-frequency cut-off. Dimensions of cabinet are 14 inches in length, 13 1/2 inches high and 11 inches wide. This speaker handles tremendous power with excellent reproduction of music and speech.

AWARDED THE RADIO NEWS LABORATORIES CERTIFICATE OF MERIT NO. 2394.

TWISTED A.C. FILAMENT WIRE

The "Twisted A.C.-Filament Celat-site" hook-up wire shown, submitted by the Acme Wire Company,



New Haven, Conn., is two-color (red and black) stranded Celat-site with non-burning insulation. The two colors eliminate difficulty in obtaining the correct polarity when wiring A.C. filament circuits. Each lead consists of 16 strands of tinned No. 30 wire. The wire is available in coils 25 feet in length.

AWARDED THE RADIO NEWS LABORATORIES CERTIFICATE OF MERIT NO. 2395.

WIRING CABLE

The "R112 Universal Cable" shown, submitted by the same company, is of the 12-wire type, and composed of stranded colored Celat-site. There are four pairs of twisted



wire: red and black (41 strands No. 30 wire), red and maroon, red and yellow, and red and blue (16 strands No. 30 wire), provided for A.C. filaments. Four single wires (white, slate, brown and green) are available for "E" and "C" voltage supply. The wires are formed into a cable encased by a neat braided covering of strong material, and may be obtained in any desired length.

AWARDED THE RADIO NEWS LABORATORIES CERTIFICATE OF MERIT NO. 2396.

HOOK-UP WIRE

The "Pushback" hook-up wire, submitted by the same company, has a single strand of No. 20 tinned wire. There are two insulating layers; the inner one, single cotton, over which is braided covering; they are impregnated with paraffin to prevent loosening of the braided covering. This wire is convenient for connections, as it may be cut to length and the insulation pushed back for soldering; after which the insulation may be pushed back to the joint. This produces a neat and efficient wiring job. The wire is available in red or black in 25-foot rolls.

AWARDED THE RADIO NEWS

LABORATORIES CERTIFICATE OF MERIT NO. 2397.

SUB-PANEL BRACKET

The sub-panel bracket shown, submitted by the Pilot Electric Mfg. Co., 323 Berry Street, Brooklyn, N. Y., is molded of bakelite, and is 8 1/2 inches long, 1 inch high, and 3/4-inch thick. Two holes are provided at the end for fastening it to the panel, while five holes in various positions are arranged along the top for any width of sub-panel. The bracket, being of insulating material,



will not introduce stray capacity effects or absorb energy. Its height and length will meet the needs of the radio set builder who requires a wide and low sub-panel.

AWARDED THE RADIO NEWS LABORATORIES CERTIFICATE OF MERIT NO. 2398.

VARIABLE GRID RESISTOR

The "Adjustograd," a variable grid stabilizer, submitted by the same company, is of the wire-wound type. Variation of the resistance is obtained by adjustment of the screw, on top of the housing, which applies pressure to a curved strip of spring brass which is made to flatten out against the resistance strip. The Adjustograd occupies a space on the sub-base or sub-panel 2 13/16 inches long by 9/16 inches wide; the overall height at minimum resistance is 1 inch. The samples submitted for test were found to have a maximum resistance within 10% of their rated values, and a minimum resistance of approximately 20 ohms. They will safely dissipate 5 watts of energy, although designed for use as grid stabilizers. The housing of molded black bakelite has a pleasing appearance.



AWARDED THE RADIO NEWS LABORATORIES CERTIFICATE OF MERIT NO. 2399.

MIDGET CONDENSER

The "Neutograd Midget" condenser shown, submitted by the same company, is of the air-dielectric type,



with a bakelite end plate into which is molded a bushing for single-hole

mounting; the plates are of hard-rolled brass. The capacity range of the 5-plate midget submitted for test was from 3 to 20 mmf., although other capacities are available. The condenser is provided also with a black bakelite knob.

AWARDED THE RADIO NEWS LABORATORIES CERTIFICATE OF MERIT NO. 2400.

ANTENNA TUNING UNIT

The antenna tuning unit (type BD-1E shown), submitted by the National Company, Inc., Malden, Mass., is of the Browning-Drake auto-transformer type. It consists of a 60-turn, center-tapped space-wound coil of modern design, shunted by a .0005-mf. (25-plate) tuning condenser of the girder-frame type made by this manufacturer. The coil is mounted in a vertical position, on the rear supporting post of the condenser frame, by a special bracket.

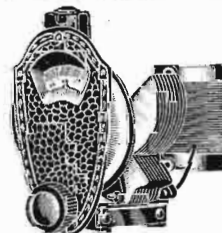

A "type B" dial (flush-panel type) is provided for turning the variable condenser. The unit is arranged for sub-panel mounting and, when assembled on the sub-panel with its dial set into the panel, has a very neat and pleasing appearance. It occupies a space 7 inches long, 4 inches wide, and 6 inches high. With the recommended aerial and series tuning condenser, the wavelength range was found to be from 200 to 550 meters.

AWARDED THE RADIO NEWS LABORATORIES CERTIFICATE OF MERIT NO. 2401.

DETECTOR TUNING UNIT

The detector tuning unit (type BD-2E), submitted by the same company, is of the three-circuit-coupler type; it consists of a 110-turn secondary winding tapped for neutralization 20 turns from the filament end. The primary winding is wound in a slot on a smaller tube which is placed inside at the filament end of the secondary; this winding has sufficient inductance to give maximum energy transfer when used in the plate circuit of the R.F. tube recommended. The movable tickler, at the grid end of the secondary, is provided with a long extension shaft for panel control. The coil is mounted in a horizontal position, with its filament end attached to the rear post of the tuning condenser by a special bracket; the secondary wind-

ing is shunted by a condenser of approximately .0003-mf. capacity (15-plate) of the girder-frame type. This unit also is provided with a "type B" dial for panel control; the space required is 7 inches long, 5 inches

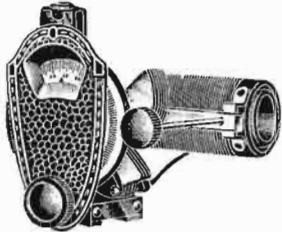

wide and 6 inches high. It is arranged also for sub-panel mounting and, when used with the antenna tuning unit described above, enables the construction of a simple and efficient radio receiver, of attractive modern design. The tuning range is from 200 to 550 meters.

AWARDED THE RADIO NEWS LABORATORIES CERTIFICATE OF MERIT NO. 2402.

VERNIER DIAL

The "Laboratory Type" vernier dial shown, submitted by the same company, is of the friction-movement type. It was designed for use on precision instruments, although it may be used on radio receivers or wherever a smooth and positive vernier adjustment is desired. The dial has accurate graduations from 0 to 100 over half a circle; on the top portion of the frame is a graduated scale for vernier readings. In mounting, the dial's collar (which is 7/16-inch in diameter and extends



approximately 1/2-inch from the back of the dial) is passed through the panel; the collar has a set screw for tightening it upon the shaft of the instrument. The dial is 4 inches in diameter and the frame is 5 inches long over all; the knob of black molded bakelite is 2 inches in diameter. The dial and frame are of nicked metal with satin finish and neat in appearance.

AWARDED THE RADIO NEWS LABORATORIES CERTIFICATE OF MERIT NO. 2403.

INSTRUMENT FUSES

The "Littelfuses" shown, submitted by the Littelfuse Laboratories, 1772 Wilson Avenue, Chicago, Illinois, are quick-acting fuses of low current ratings; the sizes submitted for test were 1/32, 1/16, 1/8, 1/4, 1/2, 1 and 2 amperes. They were found on test to fuse at a current value very close to the figure given by the manufacturer. To protect the tubes of a radio receiver, one of suitable current rating should be selected; the fuse is inserted in the negative "B" voltage supply; when it is used with instruments the fuse is placed in series with one lead of



the instrument. The fuse is 1 inch in length and has an over-all diameter of 1/4-inch; mounting blocks are obtainable, the dimensions of which are 1 3/8 inches long, 1/2-inch wide,

and 3/16-inch thick. Cap grips ("Grip-connectors") are also obtainable; these may be slipped over the ends of the fuses, connected into the circuit by inserting the wires into the holes provided, and fastened by tightening the thumb nuts. These fuses may be recommended to the careful experimenter as instrument and tube insurance.

AWARDED THE RADIO NEWS LABORATORIES CERTIFICATE OF MERIT NO. 2404.

A.C. TUBE PROTECTOR

The "Protector" (Model 6 shown) submitted by the Protecto Mfg. Company, Brooklyn, N. Y., is designed for the protection of the A.C. tubes of an electric receiver. It is essentially a fixed resistor, which is placed in series in one leg of the A.C. line between the light socket and the radio set; the resistance of the unit submitted for test was 7 ohms at 1/2 ampere. It is arranged



in such manner that the user has only to plug it into a lighting receptacle, and then insert the line cord of the receiver in the receptacle side of the device; this automatically places the resistance in series with the line. The device is 1 1/8 inches in diameter and has an over-all length, to end of receptacle prongs, of 3 1/2 inches.

AWARDED THE RADIO NEWS LABORATORIES CERTIFICATE OF MERIT NO. 2406.

MICA BALANCING CONDENSER

The small adjustable balancing condenser shown, submitted by the Remler Division of Gray and Danielson Mfg. Co., 260 First Street, San Francisco, Calif., is of the mica-dielectric type and designed for balancing or compensating radio-frequency circuits; it has a capacity range between approximately 5 and 85 mmf. The condenser proper is very small, being but 3/8-inch in diameter by 1/2-inch thick, over all. It is provided with a mounting bracket, connected to the stationary condenser plate, approximately 1 1/4 inches in length and 7/16-inch wide,



which may be bent at any angle for convenient mounting; the adjustable plate has a pigtail connection provided for soldering to the stator of the condenser to be compensated. The adjustment is obtained by turning the screw near the edge; which applies pressure to the movable plate, causing it to flatten against the mica and thereby increasing the capacity.

AWARDED THE RADIO NEWS LABORATORIES CERTIFICATE OF MERIT NO. 2407.

REMOTE-CONTROL RECEIVER RELAY

The "Lotus" remote-control relay shown, submitted by Garnett, Whiteley and Company, Ltd., Lotus Works, Broadgreen Rd., Liverpool, England, provides remote control for any receiver operating from either a D.C. or an A.C. line; it is so arranged that the receiver can be operated from any number of points by the use of additional wall jacks. The relay is designed to operate from a 3-volt battery, and the 110-volt contact points are sufficiently heavy to carry the load that might be imposed by any receiver. A socket is provided for connection to the receiver, and an extension cord with plug for

the line socket or receptacle. Special four-strand wire cable is used for leads to the remote jacks. The relay,

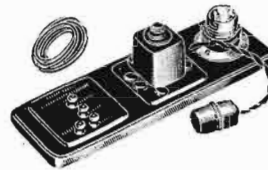

which should be mounted in close proximity to the radio receiver, requires a space 9 1/4 inches long by 3 1/4 inches wide. The overall height is 3 inches. The insulating parts (base and housing) are of black molded bakelite.

AWARDED THE RADIO NEWS LABORATORIES CERTIFICATE OF MERIT NO. 2408.

SPECIAL WALL JACK AND PLUG

The "Lotus" special wall jack shown, submitted by the same manufacturer, is of special design and is used in connection with the "Lotus" relay, for control as well as to allow the speaker to be connected to a distant radio receiver. It is of the open-circuit filament control type; although the filament control is used



in this case to operate the relay field winding, by opening or closing the circuit in which is a 3-volt battery. The jack is mounted in a black molded bakelite housing, whose overall dimensions are 2 3/4 inches long, 2 1/4 inches wide and 2 inches high.

AWARDED THE RADIO NEWS LABORATORIES CERTIFICATE OF MERIT NO. 2409.

The special plug shown, submitted as an accessory for the special jack



described above, is longer than the usual plug but has the same general construction. The plug grip is approximately 1-3/16 inches in diameter and of black molded bakelite; it is provided with two screws, by which the speaker-cord tips may be locked into position. The over-all length of the plug is approximately 3 1/4 inches.

AWARDED THE RADIO NEWS LABORATORIES CERTIFICATE OF MERIT NO. 2410.

DRY BATTERY

The "No. 665," 3-volt dry battery shown, submitted by Simcox Brothers and Company, Ltd., Woolwich Works, London, England, has been found to have a life curve of approximately 10 ampere hours when used with a small current drain. This battery is approximately the same size as the standard No. 6 dry cell; it is 6 1/4 inches long over all and approximately 2 1/2 inches in diameter. Such a battery would prove useful in a portable radio receiver or for other purposes where a greater voltage supply is desired in the same space that



would be normally occupied by a No. 6 dry cell.

AWARDED THE RADIO NEWS LABORATORIES CERTIFICATE OF MERIT NO. 2411.

R.F. CHOKE COILS

The "Magnum Standard" R.P. choke coil shown, submitted by Burns-Jones and Co., Ltd., Magnum House, 288 Borough High Street, London, England, has an inductance within 10% of the rated value of 160 millihenries (measured at 1,000 cycles) and a distributed capacity less than 8 mmf.; its D.C. resistance is somewhat less than 400 ohms. It is wound in six grooves approximately 3/8-inch in width; the diameter of the grooves and the number of turns in each slot decrease from the base to the top. The diameter of the base is 1 1/4 inches and that of the top 1/2 inch. The base is provided with two screw terminals; that for connection to the



plate of the vacuum tube is marked "A" (anode). A black molded bakelite housing fits over the cone-shaped form and is secured in place by a flat-head screw at the top. The mounting space required is 1 1/2 inches by 2 1/2 inches.

AWARDED THE RADIO NEWS LABORATORIES CERTIFICATE OF MERIT NO. 2412.

The "Magnum Short-Wave" R.F. choke coils submitted by the same maker, has the general appearance as the "Standard H.F." choke coil, but has been especially designed for use in short-wave receivers. It has less than 0.5-ohm (D.C.) resistance, and is wound with the equivalent of No. 34 D.S.C. wire, in six slots; each slot with a different number of turns, to eliminate self-resonant points. The distributed capacity was found of negligible value; the measured inductance is approximately 0.3 millihenry.

AWARDED THE RADIO NEWS LABORATORIES CERTIFICATE OF MERIT NO. 2413.

CUSHION SOCKET

The "Magnum Vibro Valve Holder" or tube socket shown, submitted by the same company, is of the spring-cushion "X" type, and



designed for the European type of "valve" or tube base. It is made in two parts; the base is fastened to the socket by spring-brass strips, which in turn serve as the socket terminals for the tube electrodes. It is approximately 1 1/2 inches in diameter and molded of black bakelite.

AWARDED THE RADIO NEWS LABORATORIES CERTIFICATE OF MERIT NO. 2414.

FIXED CONDENSER

The "Magnum" fixed condenser shown, submitted by the same company, is of the compressed-mica type;



the sample was found within 5% of its rated capacity of .0003-mf. The condenser is sealed with insulating composition in a molded red bakelite housing which measures (Continued on page 397)



Conducted by C. W. Palmer

RADIO NEWS readers send in every month an average of 5000 letters asking information on every phase of radio theory, construction and operation. We can only print the five or six replies which are of widest general interest.

Other letters will be answered by mail, if inquirers observe these rules: BE BRIEF: TYPEWRITE OR WRITE LEGIBLY IN INK ON ONE SIDE OF THE SHEET ONLY: ENCLOSE A STAMPED ENVELOPE ADDRESSED TO YOURSELF. Many letters are not readable. Simple questions will be answered free;

those asking for sketches, diagrams, data, etc., should send TWENTY-FIVE CENTS FOR EACH QUESTION: failure to enclose this will cause delay. We cannot answer for this sum questions requiring original research, intricate calculation, or patent investigation; we cannot compare the merits of trademarked apparatus, or give constructional data on apparatus whose makers withhold it. We cannot undertake to answer more than THREE QUESTIONS in each letter. If you inquire concerning a circuit which is not a standard, published one, enclose a diagram to save delay.

PERIDYNE DATA

(2304) Mr. Chas. Krayner, St. Louis, Mo. writes:

"Will you kindly help me with my Peridyne Five, which I constructed according to the design and instructions in your December issue? I used the specified parts except for the audio transformers, sockets and oscillation control. I have been reading the letters of Peridyne builders and the results they have obtained with their sets, and I am sure that my receiver is not working correctly. My desire is to correct it as follows: First, when the local stations are on the air, I cannot separate them. Each station requires 10 to 15 degrees on the dial. Secondly, there are a number of whistles indicating distant stations, but it is impossible to clear them up so that the stations can be heard. I am using a storage "B" battery for the plate supply and an outside aerial about 75 feet in length. I constructed the coils and shields exactly to your specifications and I am sure that they are satisfactory."

(A.) Because some Peridyne constructors are having trouble with their sets, we are giving a list of suggestions to overcome all of the difficulties which might be encountered with this popular receiver. We are sure that you will be able to clear your own trouble with the aid of these suggestions.

Broad Tuning

This may be caused by the use of too long an aerial or one which is not insulated very carefully. Use an aerial between 75 and 100 feet in length. This will give the correct amount of selectivity and sufficient signal pick-up so that you can receive both local and distant stations. Also, make sure that the ground connection is a good one; the use of a poor ground will greatly reduce the volume and selectivity of any set.

The main cause of broad tuning in the Peridyne receiver is lack of circuit resonance. You must match the radio-frequency stages within five percent, so that the Peridyne plates can then bring the set into exact resonance. To do this you must have the coils matched very closely—within about three percent—before they are placed inside the shields. You can match the coils by using them with a crystal detector as a small crystal receiver. Connect the small winding or primary of the first coil to the aerial and ground. If your local stations are very close by, place a small fixed condenser of about .00025-mf. in series with the aerial wire. This will reduce the volume slightly and increase the sharpness of tuning considerably. Then connect the earlironium detector or other crystal detector to one of the wires from the larger or secondary coil. The other terminal on the crystal is connected to a pair of phones and the phones are in turn connected to the other side of the secondary. You may have to connect a .001-mf. fixed condenser across the two wires to the head phones in order to hear the radio signals. One section of the gang condenser should be connected across the secondary coil, to tune it.

Tune in a local station to the maximum volume. If the tuning is not very sharp, use the small fixed condenser in the aerial wire, as explained above; or, if one is being used already, try a smaller one. After you tune in a station sharply, disconnect the first coil and try the other two in turn. If they are matched correctly you will not have to readjust the variable condenser. If you

find that the signals with one coil are stronger when the variable condenser is turned higher (with the plates further in mesh), remove a small amount of wire from the secondary until the signal comes in strongest with the condenser set at the exact position required for the other coils. Add wire to the secondary if the condenser setting is lower than that required for the other coils.

After the set is assembled, you should match the tuned circuits again. This time, remove the first radio-frequency tube from its socket and bridge the crystal circuit across the secondary winding of the first R.F. transformer. The shields should be in place with the adjustable plates at the highest point, when balancing in this case. Note the exact position of the gang condenser for a local station. Then remove the aerial and ground wires from their binding posts and connect them (temporarily, by means of clips) to the primary of the second radio-frequency transformer, and repeat the foregoing test with the crystal across the second transformer, of course. Repeat with the third transformer. If the condenser readings do not match exactly, add or remove wire from the secondary windings, as advised in the previous paragraph.

Use a triple condenser in which each section has exactly the same capacity as the other sections on each part of the scale. The specified condenser was equipped with small condensers to adjust each section of the condenser individually. If one of the tuned circuits has a higher reading than the others for a local station, separate the wiring further or reduce the number of turns on the secondary coil slightly until the signal is loudest when the condenser is tuned to exactly the same point required for the other coils. When the circuits are all in resonance, a very slight fraction of a turn on the Peridyne plates will change the operation of the circuit. You will notice this to some extent by broadening of the tuning. The radio-frequency circuits will oscillate violently when perfect resonance is reached, although this action is under perfect control by varying resistor R3 in the set. This resistor must have the correct value, 6-100,000 ohms.

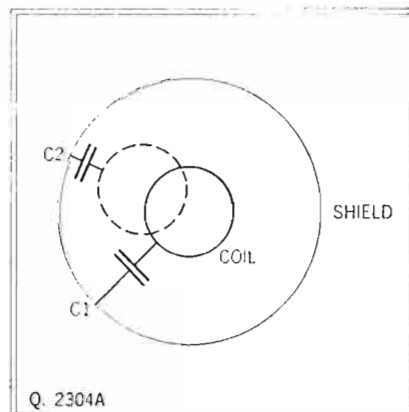

The centering of the coils in the shields is very important. The change in the capacity between the coil and the shield when the former is off center is shown by C2. C1 is the normal capacity.

Broadness of tuning might also be caused by too close coupling between the primary and the secondary coils. When constructing the coils for this set, keep the spacing between the turns of wire on the secondary coil very accurate. If the spacing between the turns of wire on the different coils is not exactly the same, the capacity between the turns of wire will be different, and this will be sufficient to change the tuning characteristics of the coils. When building them, follow the instructions given in the December issue of RADIO NEWS, both for winding the secondary coils and for placing the primaries in the correct position in reference to the secondaries.

Improper wiring might also cause broad tuning, since it might introduce interactions between the circuits, which should be kept entirely separate. Follow the exact layout specified and wire the apparatus according to the instructions given in the constructional article and in the picture diagrams. The final cause of broad tuning is improper adjustment of the shield plates. If the plates are too close to the coils, losses will be introduced which will be sufficient to "damp" the circuits.

If the dial reading for one of the coils is lower than the other two, this coil can be brought to resonance by moving it a little to one side of the center of the shield. This will increase the capacity between the wire in the coil and the wall of the shield and will increase the tuning range of the coil. Fig. Q2304A indicates this effect. Notice that a capacity exists between the side of the coil and the shield, and when the coil is moved closer to the wall of the shield, this capacity is increased. This also shows why the coils must be centered very carefully in the shields after they have been matched previously.

Volume and Sensitivity

If the set does not have the "pep" that is expected from it, the trouble is due to poor tubes, too high a "B" voltage on the plates of some or all of the tubes, incorrect "C" bias, lack of circuit resonance, defective parts or the incorrect placement of the crystal detector. If the tubes are suspected, the only thing to do is to try new ones. However, first check the plate and grid voltages on the tubes in order to be sure that these values are correct. The lack of circuit resonance can be overcome as explained previously.

Distortion

This is usually due to the first (detector coupled) audio-frequency tube being overloaded. If a 201A tube is used in this socket, the plate voltage should never exceed 22½ volts. The results can often be improved by reducing this value.

A 112A tube can be used in this position with slightly better results and the "B" voltage may be increased. In this case, however, it may be necessary to insert a "C" battery between the negative filament side of the last radio-frequency transformer and the negative "A" battery terminal. The value of this "C" battery depends upon the plate voltage, but a value of 1½ to 3 volts will usually be sufficient. The negative terminal of the battery should be connected to the secondary terminal of the coil and the positive terminal of the battery should be connected to the negative filament terminal. Connect a by-pass condenser of about .05-mf. capacity across the "C" battery.

You must also adjust the filament rheostats very carefully. This point was explained thoroughly in

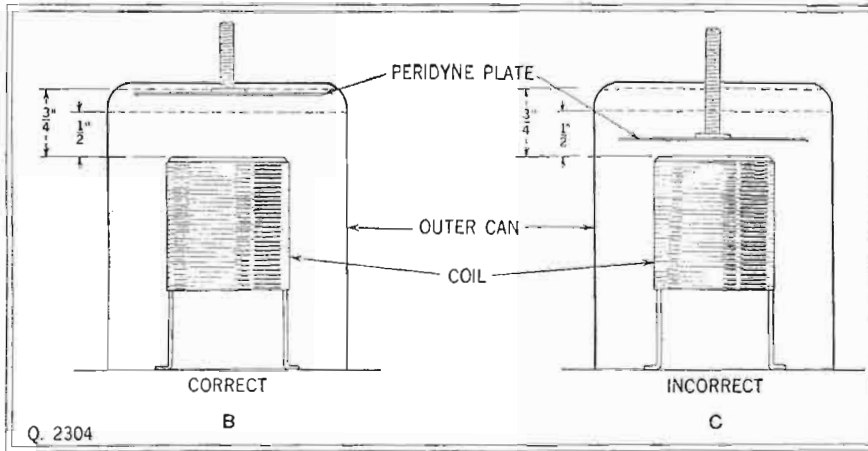

To get the greatest efficiency from the Peridyne 5, the adjustable plates must be in the correct relation to the coils. If they are closer than 1/2-inch, the results will be poor.

the constructional article. Distortion may arise from overloaded audio-frequency tubes in the other stages, or from poorly designed audio-frequency transformers. The choke coil and the by-pass condenser in the plate circuit of the first audio-frequency tube, if they are of the wrong value, will also cause distortion. Use the specified parts in these positions.

Interflex Detector

The Carborundum crystals used for detection do not all work equally well, and most of them will only work in one way. By reversing the position of the crystal, the volume and clarity can often be increased considerably. In order to obtain clear reception, in some cases, you may have to place a small by-pass condenser between the crystal and the negative "A" battery terminal on the tube socket. This condenser should be connected to the side of the crystal which is connected to the grid terminal on the tube socket. A small semi-variable condenser, between 20-mmf. and 500-mmf., can be employed for this purpose. By adjusting this condenser the required capacity can easily be obtained.

Wiring

The wiring in the Peridyne set is extremely important and you must do it very carefully. Considerable interaction can be prevented by separating the grid and plate leads as far as possible. The plate and "B" plus leads can be bunched together if desired. At the points where the grid and plate leads cross, an angle as close to 90 degrees as possible should be used. All of the grid and plate leads should be as short as possible.

Coils and Condensers

The distance between the bottom of the R.F. transformers and the bottoms of the shields can vary between 1 inch and 1 1/4 inches with no great change in the efficiency, providing all of the coils are exactly the same distance from the bottoms. You must place the coils in the exact center of the shields (when looking from the top), so that the capacity between the coils and shields will be the same in each case. This position can be changed slightly if necessary, as explained under "Broad Tuning."

If the circuits do not match within five percent, you will not be able to get the correct balance, and the Peridyne plates will apparently have no effect on the operation of the set. This is due to the fact that the capacity between the Peridyne plate and the top of the coil has a very small value. It was found on test in the Radio News laboratories that the maximum capacity was approximately .000013-mf. when the Peridyne plate was touching the top of the coil, and the minimum capacity .00000775-mf. when the shield plate was as far away from the coil as possible.

Peridyne Shield Plate

The constructional article on the Peridyne receiver explained that when the Peridyne shields were used in other circuits, the shield plate should never be closer than one inch. The article also explained that because of the method of stabilizing used in the Peridyne, this value can be decreased to within one-half or three-quarters of an inch. (See Fig. Q. 2304 B and C.) Less than one-half of an inch will result in a considerable absorption of the current from coil, and as the distance is decreased, the efficiency of the circuit will fall off greatly. The normal position for the

shield plate in the can is very close to the top, usually not more than 4 complete revolutions of the adjusting knob when the No. 32 screw is used. When the set is completely balanced, a quarter of a turn of the adjusting knob will be sufficient to throw the coil in and out of resonance.

VOLUME CONTROL IN A.C. SETS

(2305) Mr. W. O. Pearce, Bayonne, N. J. writes:

"In constructing an A.C. set, I am encountering difficulty in knowing just how to control the volume. The usual filament control method is, of course, out of the question because of the sluggish operation of the filaments in A.C. receivers. Can you help me out in this matter?"

(A.) The tube manufacturers suggest a system which is a very convenient and satisfactory one. It consists of a potentiometer connected in the aerial circuit, according to Fig. Q. 2305A or B. In the first case, a potentiometer of about 3,000 or 4,000 ohms resistance, with the slider connected to the grid circuit and the two outer terminals to the aerial and ground, is employed. This method is usually used when a new set is being constructed. It eliminates one of the tuning controls. The other method makes use of a potentiometer with a resistance of about 25,000 ohms. The slider in this case is connected to the primary of the antenna coupling coil, while the two outer terminals are connected to the aerial and ground. This method is more suitable for equipping an existing receiver.

There are several other methods which are satisfactory for controlling the volume of sets of this type, including the use of a 50,000-ohm variable resistor connected across the secondary of one of the radio-frequency transformers, and the use of a high resistor in series with the positive "B" battery terminal supplying current to the radio-frequency tubes. The last mentioned method, however, may cause trouble with hum.

A SHORT-WAVE SUPERHETERODYNE

(2306) Mr. C. O. Lorenz, San Antonio, Texas, writes:

(Q.) "Can I take an eight-tube Ultradyne receiver, remove the antenna coil and oscillator coil, and replace them with plug-in coils for short waves? Will the oscillator work correctly with these few turns and could the tickler coil in the modulator circuit be wound to cover all of the short-wave bands? If the Ultradyne circuit will not work correctly in this matter, will you give me the constructional details for a suitable short-wave superheterodyne, specifying the correct intermediate-frequency amplifier and giving the values of all the parts used?"

(A.) We do not believe that the model L-2 Ultradyne would be satisfactory for receiving short waves, since the values of the tuning condensers, both in the aerial and oscillator circuits, would have to be changed; and we doubt if the oscillator would operate correctly on the very short wavelengths. The .0005-mf. tuning condensers employed in this set have too great a minimum capacity to be used successfully with a short-wave set, and this would necessitate removing them and replacing them with .00015- or .00025-mf. condensers. On the broadcast band, the set would not operate satisfactorily with these smaller condensers.

We are printing the diagram and specifications for a short-wave superheterodyne which will work very efficiently on wavelengths up to about 150 meters. The set was constructed by the writer with a second oscillator coupled as shown to the last I.F. transformer. This was used to receive continuous wave code signals. The set employs four tubes in the radio-frequency section, which would make a total of six tubes in the complete receiver. Three or four stages of intermediate frequency amplification may be used instead of the two specified, thereby increasing the radio-frequency amplification and also the sensitivity.

This short-wave superheterodyne consists of a short-wave regenerative detector circuit of the usual type, coupled to an intermediate-frequency amplifier operating on a rather low frequency. When dealing with waves below 125 or 150 meters, the detuning to an incoming signal offered by an oscillating detector is not sufficiently great to cause any appreciable loss in signal strength. For this reason, we can make the first detector self-heterodyning. In this way, it can be made to furnish the intermediate frequency, by heating on the incoming signal. This arrangement is similar to that used in the usual superheterodyne, except that with the latter a separate oscillator is used.

In Fig. Q. 2306A, the coils L1 and L2 are the primary, secondary and tickler respectively of the input circuit; they can be almost any form of coil designed for short-wave work. (The coils specified for the five-tube, short-wave and broadcast receiver described in the April, 1928 issue of Radio News will be ideal for this purpose.) The tuning condenser C1 has a capacity of .00015-mf., and the regeneration control C2 a value of .00025-mf. The radio-frequency choke coil in the detector plate lead is extremely important, and a very good one should be used.

As you will notice, the grid return of the detector is placed on the negative "A" battery terminal. It was found that this method gave more stable operation than the usual positive return, although both methods should be tried and the better one used. If you desire to make the radio-frequency choke coil, it can be wound on a one-half inch tube with approximately 150 turns of No. 30 to 36 double cotton covered wire.

Intermediate-Frequency Amplifier

The intermediate-frequency amplifier in this receiver is of the usual type, with two broadly tuned transformers and a rather sharply tuned filter. A potentiometer is used for controlling oscillation.

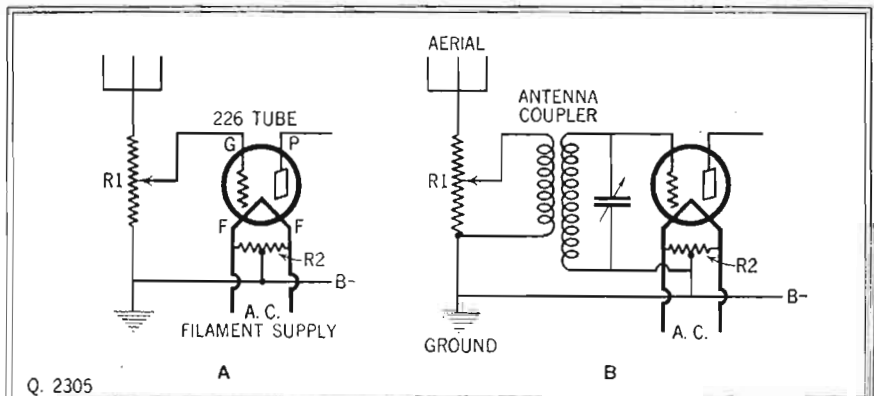

Two methods of coupling the aerial of an A.C. receiver to the first tube are shown here. In A, the resistor, R1, has a value of 3,000 ohms; in B, the resistor, R1, is about 25,000 ohms. R2 in both cases is the ordinary filament resistor.

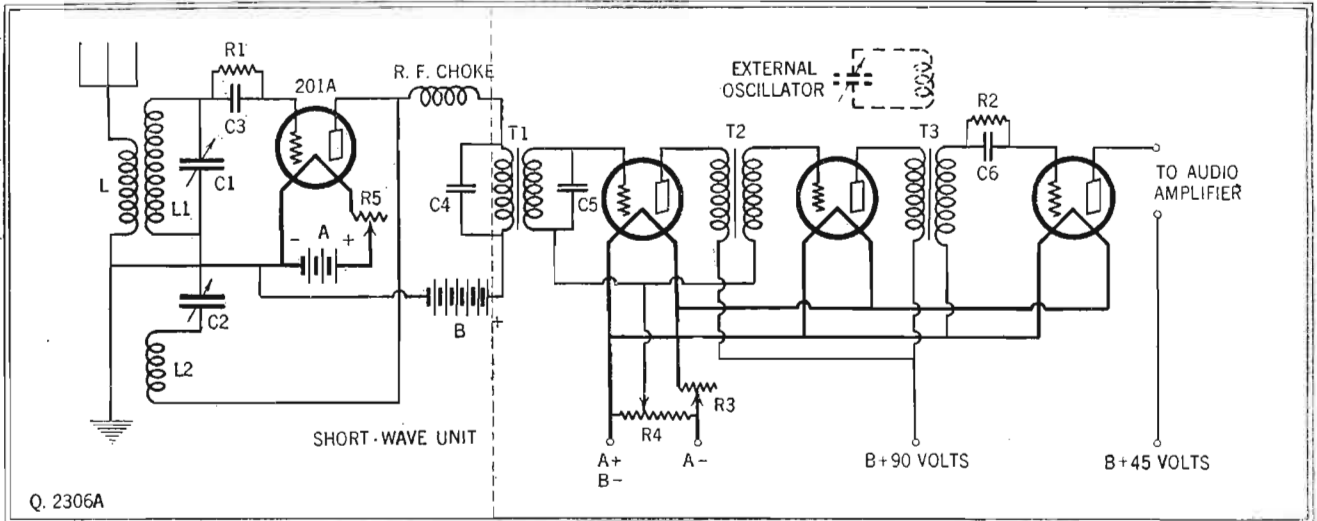

An ordinary short-wave regenerative receiver can be made into a short-wave superheterodyne, by coupling it to a 30-kilocycle intermediate-frequency amplifier. A separate "B" battery is used for the first tube.

The filaments are controlled either by a rheostat or by automatic filament ballasts. The potentiometer should have a resistance of about 400 ohms; an ordinary 10-ohm rheostat will be satisfactory for controlling the filament current. The detector is coupled to the last I.F. transformer through a grid condenser and grid leak, C6, R2. The condenser C6 has a value of about .00025-mf.; the value of the grid leak depends upon the characteristics of the detector tube. A resistance of about 2 meg-ohms will be suitable for most tubes.

The primary and secondary of the filter coupler are shunted by .0005-mf. fixed condensers. These condensers must be matched closely in order to produce satisfactory results; it may be advisable to use semi-variable condensers so that the two circuits can be adjusted correctly. The filter coupler is wound on two separate spools, as shown in Fig. Q. 2306B. Wooden discs two inches in diameter and three-quarters of an inch wide are used for the cores; the sides are fibre discs four inches in diameter. The two spools are fastened together with a long brass screw and several nuts, as shown. By adjusting the distance between the two coils, the tuning can be made sharper or broader, as desired. Both the primary and secondary are wound with No. 32 D.C.C. wire and each contains 950 turns. The wire should be wound jumble fashion and not in layers.

The broadly tuned intermediate-frequency transformers are constructed with iron cores. A piece of three-quarter inch fiber tubing about 7/8 inch long is used to hold the core. Soft iron wire of about 24 gauge is packed into this tube until no more can be forced in. It is advisable to use enameled wire or to insulate the wires with shellac before placing them in the tube. The spools are made by forcing fibre discs 2 inches in diameter over the 3/4 inch tube, as shown in diagram Fig. Q. 2306C. The primary is wound with 2,500 turns of No. 36 enameled wire and the secondary with 2,600 turns of the same wire.

The intermediate-frequency transformers should be spaced about 2 inches apart and the cores should be at right angles. In the original receiver, an external oscillator was coupled inductively to the

last intermediate-frequency transformer. This oscillator was used for the purpose of receiving continuous-wave code signals. The audible beat note is produced by the signal in the intermediate-frequency amplifier, mixing with the current of the oscillator. In the usual regenerative receiver, of course, the oscillation produced by the feedback coil is used to produce this audible frequency.

The oscillator was of the standard Hartley type, with two 600-turn honeycomb coils for the inductors. A tuning condenser of .001-mf. maximum capacity was used to obtain the exact frequency desired. This frequency should be between 600 and 1,000 cycles higher or lower than the intermediate frequency used in the amplifier; the best adjustment is found by trial.

The audio-frequency amplifier has been omitted, since any good type of amplifier may be employed. It is advisable to use separate batteries for the detector-oscillator and the intermediate-frequency amplifier. If desired, the "A" battery can be common, but much better results are noticed when a separate "B" battery is used for the first tube. This battery should have a value between 22 and 45 volts, the correct voltage, of course, depending upon the tube used in this circuit. The condenser C3 in the grid circuit of the short-wave unit should have a capacity of .0001 mf.; the grid-leak value will have to be found by experiment.

is as follows: the actuating voltage from a "C" battery causes the crystal to get thinner and to become longer between the metal plates. Because of the strained position of the crystal, it starts to release or get thicker and this starts a pendulum-like action which is maintained by the exciting voltage and the alternating current in the grid circuit of the tube. The expansion and contraction of the crystal produces an alternating current, as explained above.

In making the crystals, they are cut very carefully on planes determined by measurements with optical instruments and they are then ground down with the opposite sides perfectly smooth and parallel. The thickness of the crystal is generally used to determine the frequency, and manufactured crystals are finished either round, square or oblong. The crystal mounting consists of two plates of a good conducting metal, such as copper or brass. The surfaces of the metal between which the crystal is held are ground smooth, and the crystal is usually held in place by the pressure of a spring on one of the plates.

In testing the crystals, a vacuum-tube circuit with a receiving tube is used. The grid circuit of the tube contains the crystal shunted by the "C" battery, which has a radio-frequency choke coil in series with it. The plate circuit contains an inductance coil of suitable size, shunted by a variable condenser in series with a hot-wire milliammeter. As the condenser and coil are tuned approximately to the fundamental frequency of the crystal, the hot-wire milliammeter starts to register. When the two circuits are exactly in resonance, the tube stops oscillating because the tuned choke circuit in the plate has an extremely high impedance at the working frequency. For this reason, in a transmitter, this circuit is always tuned to a slightly different wavelength than the crystal.

Quartz crystals are being used more and more. Practically all of the large broadcast stations employ them now to keep their waves constant.

PIEZO-ELECTRIC CRYSTALS

(Q. 2) What is the piezo-electric effect and how is it used in radio? I have often heard of quartz crystals and piezo-electric crystals being used in transmitters but I am at a loss to know where to find information on this subject.

(A. 2) When a piece of quartz of correct shape is placed between two metal plates, a condenser is formed with the quartz as the dielectric and the metal pieces as the plates. When the plates are connected to a source of alternating current, the quartz is found to expand and contract; as the charges on the plates increase and decrease, due to the changes of polarity. It is also found that an alternating potential is generated by the crystal itself; this can be detected if a sensitive galvanometer is connected to it. From this explanation it will be seen that the action is reversible: alternating electric currents cause the crystal to expand and contract, and lengthening and shortening of the crystal cause it to produce alternating electric impulses in the plates.

Although this action takes place to some extent on any frequency, the action is much greater on one frequency, depending on the size and thickness of the crystal. The thinner and shorter the crystal, the higher the natural or resonant frequency. When a crystal is placed in the grid circuit of a vacuum tube and an exciting voltage is impressed on it, it immediately starts to expand and contract, which causes the plates to become charged. If the vacuum-tube circuit is tuned to a frequency close to that of the natural frequency of the crystal, the crystal will feed currents of this frequency to the grid of the tube, whose plate circuit will deliver more powerful impulses at the same frequency. These currents are then amplified and impressed on the antenna, in the case of a transmitter.

Another explanation of the action of the crystal

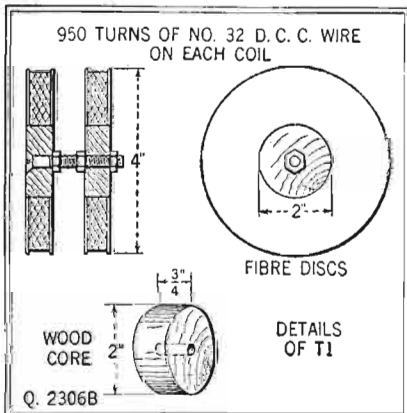

The tuned filter for an intermediate amplifier of about 30 kilocycles can be made as shown above.

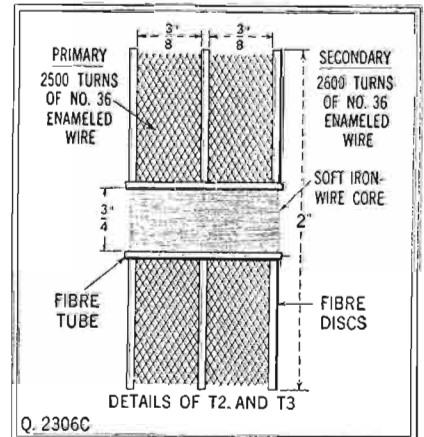

Broadly tuned transformers with iron cores for the amplifier may be constructed around a 3/4-inch tube in this manner.

A NEW NOTE IN AUDIO AMPLIFICATION

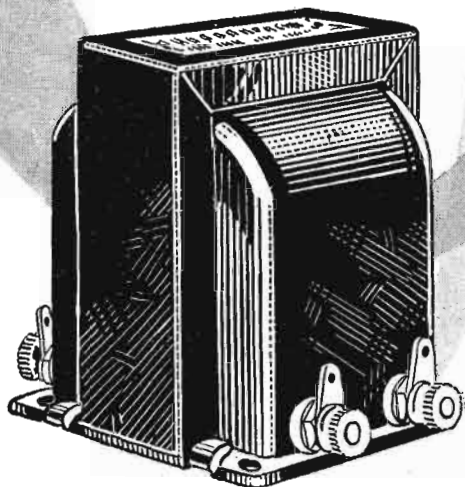

THORDARSON R-300 AUDIO TRANSFORMER

SUPREME in musical performance, the new Thordarson R-300 Audio Transformer brings a greater realism to radio reproduction. Introducing a new core material, "DX-Metal" (a product of the Thordarson Laboratory), the amplification range has been extended still further into the lower register, so that even the deepest tones now may be reproduced with amazing fidelity.

The amplification curve of this transformer is practically a straight line from 30 cycles to 8,000 cycles. A high frequency cut-off is provided at 8,000 cycles to confine the amplification to useful frequencies only, and to eliminate undesirable scratch that may reach the audio transformer.

When you hear the R-300 you will appreciate the popularity of Thordarson transformers among the leading receiving set manufacturers. The R-300 retails for \$8.00.

THORDARSON ELECTRIC MANUFACTURING CO.
Transformer Specialists Since 1895
WORLD'S OLDEST AND LARGEST EXCLUSIVE TRANSFORMER MAKERS
Huron and Kingsbury Streets - Chicago, Ill. U.S.A.



Power Supply Transformers

These transformers supply full wave rectifiers using two UX-281 tubes, for power amplifiers using either 210 or 250 types power amplifying tubes as follows: T-2098 for two 210 power tubes, \$20.00; T-2900 for single 250 power tube, \$20.00; T-2950 for two 250 tubes, \$29.50.

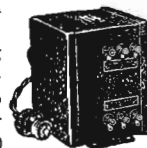

Double Choke Units

Consist of two 30 henry chokes in one case. T-2099 for use with power supply transformer T-2098, \$14; T-3099 for use with transformer T-2900, \$16; T-3100 for use with transformer T-2950, \$18.



Power Compacts

A very efficient and compact form of power supply unit. Power transformer and filter chokes all in one case. Type R-171 for Raytheon rectifier and 171 type power tube, \$15.00; Type R-210 for UX-281 rectifier and 210 power tube, \$20.00; Type R-280 for UX-280 rectifier and 171 power tube, \$17.00.

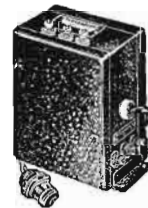

Speaker Coupling Transformers

A complete line of transformers to couple either single or push-pull 171, 210 or 250 power tubes into either high impedance or dynamic speakers. Prices from \$6.00 to \$12.00.



Screen Grid Audio Coupler

The Thordarson Z-Coupler T-2909 is a special impedance unit designed to couple a screen grid tube in the audio amplifier into a power tube. Produces excellent base note reproduction and amplification vastly in excess of ordinary systems. Price, \$12.00.



THORDARSON ELECTRIC MFG. CO.

500 W. Huron St., Chicago, Ill.

3583-L

Gentlemen: Please send me your constructional booklets on your power amplifiers. I am especially interested in amplifiers using.....tubes.

Name.....

Street and No.....

Town.....State.....

Enjoy Any Miraco 30 Days

—then decide. Return EVERYTHING, our expense, unless thoroughly delighted.

Wonderful Selection of Beautiful New Cabinets

For AC-9, AC-8 and Battery 7's and 6's

30 DAYS' TRIAL—TAKE YOUR PICK



Richly designed, genuine walnut console of finest type. Electro-dynamic cone, magnetic cone or long air column speaker. Wonderful value!

Beautifully graceful Spinet model, handsomely designed. Genuine walnut electro-dynamic or magnetic cone. (This model for "AC-9" and "AC-8" only.)



The same charming Spinet model, for battery or AC sets. Electro-dynamic or magnetic cone or air column speaker.

A most popular walnut Hi-Boy Console, with drop-leaf desk. For all Miraco Sets. Choice of speakers. Astonishingly priced.



A Lo-Boy Console that's a gem, and very low-priced. Walnut finish. For all Miraco sets. Choice of speakers.

A new type arm-chair console (for AC sets only) that is very much admired. Genuine walnut. Electro-dynamic or magnetic cone. A splendid value.



A popular, inexpensive combination. Table model Miraco set on handsome table speaker. Table speaker also is sold separately.



Miraco table model sets may be had in metal or wood cabinets. Wood cabinets in walnut or new shaded silver-chrome finishes. Cathedral electro-dynamic or magnetic speakers to match.

Latest All-Electric "AC-9"

Super-Shielded AC Chassis

\$83.75

Speaker, tubes and cabinet extra

Newest Type

6-Tube

Battery-Operated

Super-Shielded

Chassis

Equipment extra

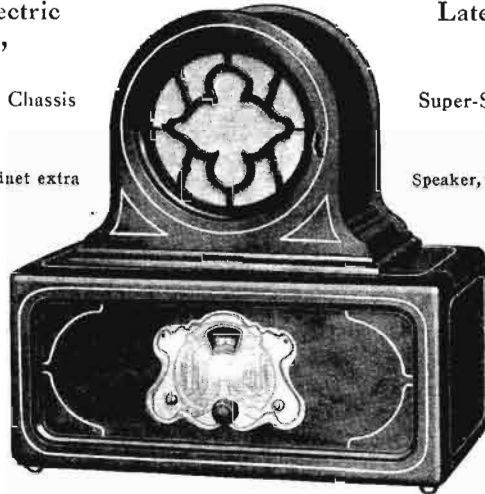

Latest All-Electric "AC-8"

Super-Shielded AC Chassis

\$71.50

Speaker, tubes and cabinet extra

Newest Type

7-Tube

Battery-Operated

Super-Shielded

Chassis

\$49.88

Equipment extra

MIRACO

TRADE MARK REGISTERED

Cathedral Tone—Super-Selective—Powerful Distance Getters

Celebrating its ninth successful year, America's big, old reliable Radio Corporation springs a genuine sensation in high-grade sets. With its latest, super-powered, 1-dial Miraco's—the wholly self-contained.

Many thousands of Miraco's—bought after 30-day home comparisons—are cutting through locals and getting distance with the tone and power of costly sets—their delighted users report. Miraco's are laboratory-built with finest parts, and embody nine years' actual experience in constructing fine sets. Approved by radio's highest authorities.

Big Discounts to User-Agents

A Miraco will so delight you and those who hear it that people will ask you to get Miraco's for them. In this way our sales grow by leaps and bounds each year. No selling necessary—no radio experience needed. You can easily pay for your set and make as much extra money as you wish, spare or full time, by getting our Amazing Special Offer.

Compare a Miraco with highest-priced radios, for 30 days in your home. Surprise and entertain your friends—get their opinions. Unless 100% delighted, return everything—the complete outfit—at our expense. Your decision is final—absolutely! Only exceptionally fine radios, of the very latest approved type, at rock-bottom prices, could possibly back up so liberally unconditional a guarantee. Send coupon now for Amazing Special Factory Offer!

direct with radio's old reliable builders of fine sets—ninth successful year.

Don't Confuse with Cheap Radios

With its rich, clear cathedral tone, hum-free operation, tremendous "kick" on distant stations and razor-edge selectivity—with its costly, sturdy construction, latest features, beauty, ease of tuning and economy—a Miraco will make you the envy of many whose radios cost 2 to 3 times as much.

IMPORTANT NOTICE!

"30-Day Free Trial" offers usually are money-back guarantees, frequently only on the "set." Please understand that unless you are thoroughly pleased we pay return charges and refund the FULL purchase price on both the "set" and ALL equipment—tubes, cabinet, speaker, antenna (also on batteries or eliminators with 6- and 7-tube sets). Could any offer be fairer?

MIDWEST RADIO CORP'N, 404-AO Miraco Bldg., Cincinnati, Ohio



BEAUTIFULLY ILLUSTRATED CATALOG, AMAZING SPECIAL FACTORY OFFER, TESTIMONY OF NEARBY USERS—All the proof you want—of our honesty, fairness, size, financial integrity, radio experience and the performance of our sets—including Amazing Factory Offer—sent with catalog.

Free!

MIDWEST RADIO CORPORATION,
Pioneer Builders of Sets—Ninth Successful Year,
404-AO Miraco Building, Cincinnati, Ohio.

THIS COUPON IS NOT AN ORDER

WITHOUT OBLIGATION, send free catalog, Amazing Special Factory Offer, testimony of nearby users, etc.

..... User Agent Dealer

Name..... Address.....

Please say you saw it in RADIO NEWS

BENJAMIN

Cle-Ra-Tone Radio Sockets

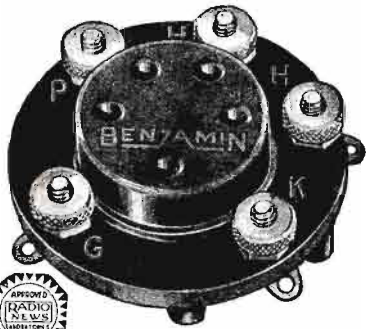

Specially Designed
for
A. C. Detector Tubes

Spring supported, shock absorbing. The tube-holding element "floats" on perfectly balanced springs. Reduces microphonic disturbances, tends to lengthen life of tube, and lessens the possibility of short-circuiting closely-spaced tube elements.

Y-Type, Green Top, for 5 Prong A. C. Tubes: for mounting on top of panel, \$1.00; for direct attachment to panel, 75c.

Red Top, for Standard UX Type Tubes: For mounting on top of panel, 75c.; for direct attachment to panel, 50c.

Shelf Supporting Brackets

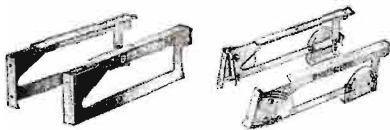

A decided advantage for the neat and substantial construction of the set. Used when panel and subpanel are assembled to make one complete removable unit. The Adjustable Brackets permit panels to be mounted vertically or at any desired angle.

No. 8629—Rigid—70c. per pair
No. 9029—Adjustable—\$1.25 per pr.

At all Radio and Electrical
Dealers and Jobbers

Benjamin Electric Mfg. Co.
120-128 S. Sangamon Street
Chicago

New York San Francisco
247 W. 17th St. 448 Bryant St.

The Search for the Perfect Amplifier

(Continued from page 339)

put impulses would, in effect, be shorted across the "B" battery. Tubes of the 199 or 201A types should be found quite suitable in either position.

Considering the circuit functionally; presumably the rectified half-wave proceeds from the plate to the filament circuit and there influences the electrons emitted from the amplifier filament, being received in an amplified form in the grid output circuit.

We have achieved a great part of our amplifier ideal in dispensing with all electro-magnetic and electro-static couplings and providing a direct low-resistance path between detector output and amplifier input. Any distortion that now occurs is due solely to incorrect operating conditions and the remedy is within the scope of any radio fan.

SECOND STAGE NOT AVAILABLE

The only snag lies in the fact that, as yet, I have not found it possible to add a further similar audio stage. Nevertheless, the extra volume given by one stage is quite as great as that provided by a well-designed transformer coupling. How this can be so is a little perplexing; since it would appear that the total amplification obtainable would be limited to the "mu" of the tube in use; which in the case of 199 or 201A types could not amount to more than about eight.

Undoubtedly, however, the extra amplification is provided by some form of audio regeneration or reflex action; also, it should be noted that the unconventional connections to the tube may alter its amplification factor and impedance very considerably.

Whatever happens has no adverse effect on the quality and purity of reproduction, as some super-reflex and audio-regenerative circuits unfortunately have.

Radio-frequency amplifiers may be added as desired and, to preserve the efficiency of the current as a whole, they should be properly neutralized. If further amplification on the audio side is desired, the writer recommends the addition of a stage of double-impedance coupling.

The resulting over-all efficiency of the complete five- or six-tube receiver should meet the requirements of the most ardent of DX fans and the most fastidious of musical ears.

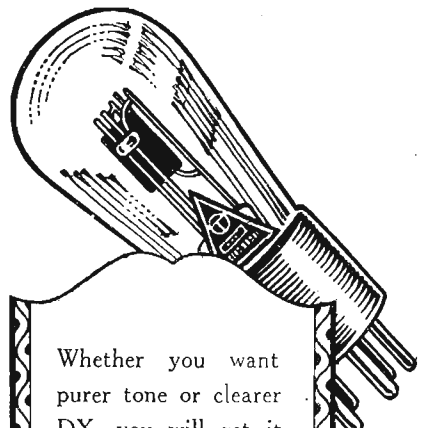

Whether you want purer tone or clearer DX, you will get it with Quality Televocals. All standard types. Ask for them at your dealers.

Televocal Corporation

Televocal Building
Dept. A-3
588 12th Street
West New York, N. J.

Televocal Quality Tubes

Lowest Prices

Tremendous stock and sales volume, with rapid turn-over to the thousands of radio dealers we serve enables us to make you worthwhile savings at lowest wholesale prices. Write for latest, new illustrated Catalog "B."

Allied Radio CORPORATION

711 W. LAKE STREET, CHICAGO

LEARN CODE

At Home with the **Teleplex Code Sender**. Reproduces actual sending of expert operators. Sends messages, radiograms, etc.—regular code traffic at any speed. You "listen and learn." No experience necessary. Endorsed by U. S. Navy and leading schools. Complete set of **Instruction Types (Wireless or Morse)** furnished. Remember only code brings you the thrill of real DX. Write for Booklet NR10.



TELEPLEX COMPANY
76 Cortlandt St., New York, N. Y.

FREE RADIO CATALOG

Since the dawn of Radio, Barawik has been known the world over as headquarters for radio set builders and fans. Here, under one roof, is everything you need—sets, parts, supplies—thousands of products—ready to ship to you the same day your order arrives. Barawik prices save you money. Barawik service saves you time. Barawik merchandise always pleases. A quarter million satisfied customers say, "Barawik is Best." Let us send you the **Big Barawik Book** free and prove it to yourself. **BARAWIK CO., 2308 CANAL ST., CHICAGO, U. S. A.**



A-C FILAMENT TRANSFORMER ONLY \$4.87

Supplies stepped down current from 110 volt 50-60 cycle lines for six type 226 tubes, two type 227 tubes, and two type 71 tubes. Guaranteed. Only \$4.87. Order today. Money back if not satisfied.

Illinois Transformer Co. 223 W. Elm St. Dept. 107, Chicago

RADIO TERM ILLUSTRATED

"AND I HAVE IT FROM RELIABLE SOURCES THAT THESE SIGNALS WILL BE ETC., ETC."



"A Grid Leak"

Please say you saw it in RADIO NEWS



Pattern No. 77

A portable instrument, moderate in price, but very effective for making the various alternating current tests required in the adjustment of filament and line voltages. Ranges of 0-3-15-150 volts are ample to check and adjust all circuits. Current draw is very small.



Pattern No. 139

High resistance voltmeter of the D'Arsonval moving coil type, suitable for use by the individual in checking and adjusting B eliminator voltages. Scale range of 0-300 volts covers all ordinary requirements. It is a thoroughly reliable instrument and can be depended upon.

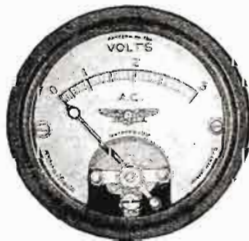

Pattern No. 190

Flush type panel mounting A.C. instrument, very valuable for panel control of A.C. filament voltage and for line voltage checking. The numerous ranges in which it is available enables a choice to cover the requirements of any radio set.



Safeguard Your Radio Investment With Jewell Instruments

Safeguarding money invested in a Radio Receiver is just as essential as the protection which you accord your other valuable investments.

In the new alternating current set you have an expensive investment, especially in the high-priced A.C. tubes, which are commonly burned out by variations in voltage of house lighting circuits. It is true that most sets carry a compensating arrangement, but which tells nothing of the voltage received by the filaments of the tubes.

Right there is where you can safeguard your investment by purchasing a suitable voltmeter which will enable you to keep your tube filament voltage in correct adjustment.

Then, too, there is the annoyance that comes with burned out tubes or when the line voltage drops to a point where reception is impossible.

Jewell has portable and panel mounting voltmeters that are exactly right for making line voltage adjustments. Ask your nearest radio dealer about them or write to us direct. Our Radio Instrument Catalog No. 15-C, together with Form No. 1145, covers them in detail. Write for a copy of each.

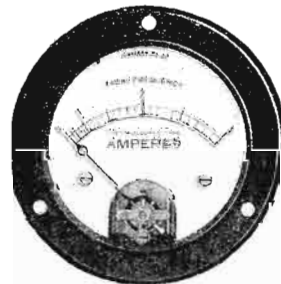

Pattern No. 64

Thermo-Couple Ammeter

A highly efficient instrument for working the short waves. Losses are less than 1/2 of the minimum required by the Navy.

The JEWELL TRIO For Amateurs and Experimenters

The Jewell Trio of amateur broadcasting instruments, Patterns Nos. 54, 64, and 74 are still making radio history. Many of the recent successful pioneering airplane ventures have been guided by Jewell instruments. Where success and life have been trusted to their reliability; they have proven their worth. Every amateur and experimenter should use them. The Pattern No. 64 above illustrates their general appearance, as they are uniform in size.

Pattern No. 54

Used for measuring plate voltage in transmitting sets as well as for general laboratory work, they are available in direct current ranges, running to relatively high voltages, and also in various ammeter and milliammeter ranges.

Pattern No. 64

A thermo couple type radio frequency ammeter. It is extremely accurate and has a guaranteed overload capacity of 50%. The losses are very low, being less than one half the Navy minimum.

Pattern No. 74

This A.C. instrument is widely used for filament control of power tubes. The movement is a rugged moving vane type of proven worth. It perfectly matches the appearance of both Patterns Nos. 54 and 64.

The Jewell Trio is described in detail in our Radio Instrument Catalog No. 15-C. Write for a copy.

"28 Years Making Good Instruments"



Jewell Electrical Instrument Co.

1650 Walnut St., Chicago, Ill.

Raytheon Kino-Lamp

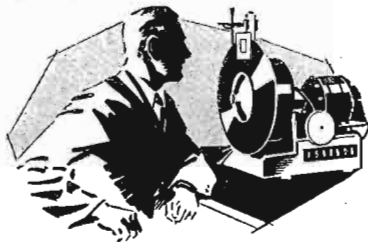
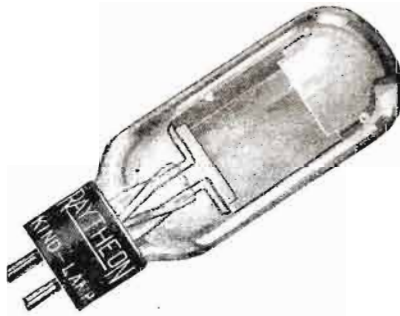

TWO PIONEER TELEVISION ACCESSORIES

The Raytheon Laboratories invite correspondence from both engineers and amateurs in regard to these two accessories now in successful operation.

Raytheon Kino-Lamp is the first television-reception tube developed to work on all systems.

Raytheon Foto-Cell, an extra sensitive broadcasting tube, is supplied in either hard vacuum or gas-filled types.

RAYTHEON MFG. CO.
Kendall Square Bldg., Cambridge, Mass.

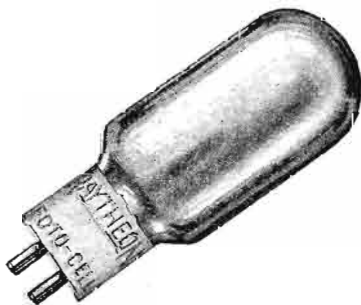

Raytheon Foto-Cell

Radio Wrinkles

(Continued from page 341)

moved from room to room—about the house. I have found that by taking the base from an old or defective UX-type vacuum tube and fastening it to the speaker terminals and putting UX-type sockets on the floor at different points in the house, the speaker can be easily moved from room to room.

The most important thing to watch out for in making this type of installation is the voltage drop in the line leading to the field winding. By using No. 14 solid wire, a 25-foot extension can be made without any noticeable drop in voltage. In my own home the speaker installation is about 40 feet from the set and "A" battery, but I have a voltage drop of only about one-eighth of a volt, which does not interfere with the operation of the speaker. I use a 210-type tube in the last stage of the audio amplifier and, although the 450 volts for the plate of this tube has to travel through 80 feet of wire before it reaches the tube, this does not seem to affect it in the least. Of course, it would be much better and safer to use some kind of output coupling device between the output of the 210 tube and the speaker. This would keep the high voltage out of the line and if a short-circuit occurred, no damage would be done.—Contributed by C. H. Jenkins.

Making a Glow Tube for Television Experiments

AN essential piece of apparatus for a television receiver is a neon tube. Television experimenters who do not have access to a vacuum pump and who are unable to purchase a neon tube of suitable size may find the following a simple expedient for this purpose.



A rectifier tube filled with gas will flash on the application of suitable voltage and may be used in television experiments.

First secure a QRS 400-milliamperere rectifying tube; these tubes can be obtained very easily and care should be taken to pick out one in which the glass is quite clear, especially in the middle. Next, apply a thin coating of banana oil over the glass and wrap the tube with a smooth piece of tinfoil extending from the base of the tube to a point about three-quarters of the way up on the glass. A square window, about the size of the image it is desired to receive, should next be cut in the tinfoil with a razor blade. This square should fall just below the horizontal level of the tube elements.

In order to place the tube in operation,

Please say you saw it in RADIO NEWS

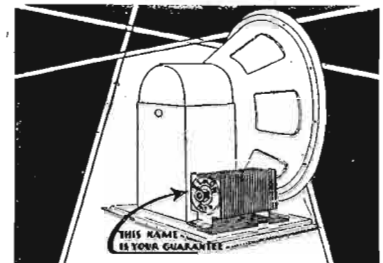

Bought Your New Dynamic Speaker Yet?

WELL, when you do, look for the Elkon Rectifier—you'll find it on good dynamic speakers about in the position shown above—no matter whether in sets, cabinets or separate units. You can't fail to recognize it, by its solid, husky appearance.

For your own protection make the dealer show you the Elkon name plate on the end of the rectifier.

ELKON RECTIFIERS

Standard equipment on the better DYNAMIC SPEAKERS, Δ ELIMINATORS and BATTERY CHARGERS



HOTEL LAFAYETTE

ATLANTIC CITY, N. J.

A new and beautifully furnished fire-proof hotel situated on South North Carolina Ave., in the Boardwalk block near the Steel Pier. Where personal service, homelike surroundings and superior food abound. Carefully selected clientele and friendly prices. Write for Booklet D.

Arthur O. Franklin, Everett L. Cope, Proprietors

EVERYTHING IN RADIO

We supply every radio need from our mammoth stock of kits, parts and sets of latest design. Lowest wholesale prices. Expert attention; immediate service. Write for big, illustrated Catalog "B."

Allied Radio CORPORATION

711 W. LAKE STREET, CHICAGO

FREE RADIO CATALOG

Since the dawn of Radio, Barawik has been known the world over as headquarters for radio set builders and fans. Here, under one roof, is everything you need—sets, parts, supplies—thousands of products—ready to ship to you the same day your order arrives. Barawik prices save you money. Barawik service saves you time. Barawik merchandise always please. A quarter million satisfied customers say, "Barawik is Best." Let us send you the Big Barawik Book free and prove it to yourself. **BARAWIK CO., 210EE CANAL ST., CHICAGO, U. S. A.**





In the studio of station W E A F, New York, from which some of the most delightful programs are broadcast.

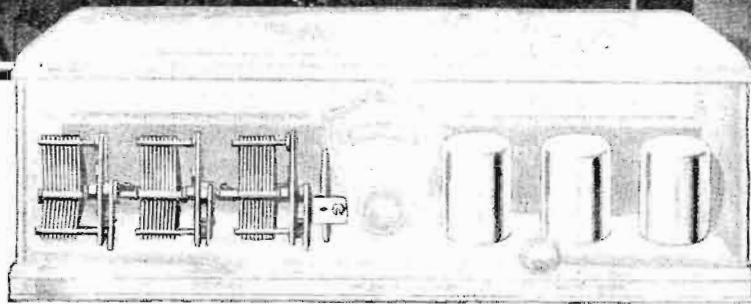

Clearer reception, finer tuning, reduced interference with aluminum equipped receiving sets.

Reception as Fine as the Broadcast

EVERY DAY millions of families throughout the world are listening to delightful broadcast programs with a keener enjoyment because their radio sets are "Aluminum equipped."

Reception is made clearer, tuning made finer, interference reduced to the minimum by designers who have found that this wonderful metal meets the varied needs of radio so admirably.

Aluminum is the ideal radio metal because it combines high electrical conductivity, permanence, beauty and extreme lightness.

Leading radio manufacturers recognize its superiority. So, in many receiving sets you find

aluminum shielding, aluminum condenser blades and frames, aluminum foil fixed condensers, chasses, sub-panels and cabinets.

When you see an aluminum equipped set you will know that its manufacturer has done everything he can to bring the true enjoyment of radio to you—to give you reception as fine as the broadcast.

Look for aluminum in the set you buy—if you build a set, by all means, use aluminum. We will be glad to send on request a copy of the booklet, "Aluminum For Radio," which explains in detail the many and varied radio uses to which this modern metal is adapted.

ALUMINUM COMPANY OF AMERICA

ALUMINUM IN EVERY COMMERCIAL FORM

2467 Oliver Building
Pittsburgh, Pa.



Offices in 19 Principal
American Cities

ALUMINUM

The mark of Quality in Radio



**Increase
your radio
enjoyment**

BY replacing each tube in your set with a new Cunningham Radio Tube you are sure of clear, resonant tone. You are virtually giving new life and energy to your radio, and you thereby increase your radio enjoyment.

Don't use old or inferior tubes with new ones—use new tubes throughout.

Look for the name
CUNNINGHAM
on the Orange and
Blue carton

E. T. CUNNINGHAM, Inc.
New York Chicago San Francisco

Cunningham
RADIO TUBES

one lead from the output of the amplifier should be connected to the tinfoil and the other to the plate of the tube. The characteristic neon glow will appear when approximately 180 volts is applied across the elements of the tube, increasing in intensity as the applied voltage is increased. Best results will be obtained when a resistance-coupled amplifier is used with a 210- or 250-type power tube in the last stage, and a high-ratio output transformer.—Contributed by Gilbert Schmidling, Chicago, Ill.

A Compact Aerial

THOSE who live in congested cities and are unable to erect an outdoor antenna will find the following type of indoor aerial convenient for use in small apartments, due to its small size and flexibility.

The material needed consists of a window screen with an adjustable frame, four small insulators and sixty or seventy feet of insulated wire such as bell wire. The netting of the screen is removed and the insulators are mounted in the corners of the frame. The aerial wire is then passed through the eyes in the insulators in a loop-like manner until twelve turns are completed; this will be found sufficient for most sets. The end of the wire is, of course, connected to the aerial binding post on the receiving set. When completed the frame may be placed in any convenient window, out of the way.—Contributed by Irving Schwartz, Brooklyn, N. Y.

New European Tubes

(Continued from page 313)

be seen from Fig. 3 and Fig. B. The dead wire running out from the screen is connected to the magnesium deposit on the walls of the bulb, thus making this form part of the screening.

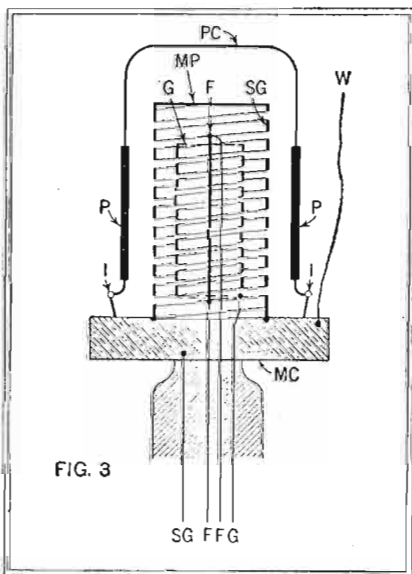

FIG. 3
The four-element tube; PC, plate connection; MP, metal plate covering screen-grid; I, insulation; MC, metal cap connected by wire W to metallic deposit on bulb, completing shielding.

Although this arrangement of the contacts makes it more difficult to use the tube in a

Please say you saw it in Radio News

**Outstanding
Reception**

Equip your Power Amplifier with a **POTTER CONDENSER BLOCK** and enjoy the pleasure of natural, life-like reception. New tone brilliancy over the entire receiving range. Bass tones become full and rich in quality.



No. T2900 where one 250 type Power Tube is used \$20.00
No. T2950 where two 250 type Power Tubes are used \$22.50

POTTER BY-PASS CONDENSERS
Withstand High Voltages—
Highest Quality

No.	Cap.	DC Working Test Voltage	Price
A-1	.1	200V 160	\$0.60
A-2	.25	200V 160	.70
A-3	.5	200V 160	.75
A-101	.1	400V 200	.70
A-102	.25	400V 200	.75
A-301	.1	750V 400	.85



POTTER CONDENSERS
Have Highest Efficiency—
Longest Life

The Choice of Leading
Radio Engineers

Ask your dealer for full information

POTTER MFG. CO.
North Chicago, Illinois

RADIO SETS
—at—
LOWEST PRICES

Every farm, every home, every man and woman needs radio this year to follow elections, markets, big national events, football, sports, music, etc. Barawik's Big Radio Guide tells you the best sets, methods and supplies to use and how to use them for best results at lowest cost. Thousands of clear illustrations and latest valuable information, furnished free. Just send for Barawik's Big Radio Guide, the guide to radio and real radio enjoyment. You can get what you want here at biggest savings. Write today for free copy. **BARAWIK CO. CHICAGO, U.S.A.** 1100 Canal Sta. Mail this Coupon for Free Radio Guide.

Name.....
Address.....



Insure your copy reaching you each month. Subscribe to **RADIO NEWS**—\$2.50 a year. Experimenter Publishing Co., Inc., 230 Fifth Avenue, New York City.

If you are really looking for a *future*
—if you are really out for **SUCCESS**

Learn RADIO

—*the most fascinating of all professions*

Well-paying positions in this *live*
industry need *trained men*

You Can Learn At Home!

RADIO offers you good pay from the start—rapid advancement—glorious adventure. It is a respected profession of fascinating brain-work where your sincere efforts can win you Success.

Our graduates are earning big money as radio designers, as executives with large radio organizations, in broadcasting work, as skilled mechanics, assemblers, service men, and radio dealers.

We have trained thousands of men to become successful radio operators on ships traveling to far corners of the globe—to become radio operators in shore stations, sending and receiving radio traffic with countries across the two oceans. And now Opportunity is knocking at your door. *Are you going to plod along at an ordinary salary when REAL MONEY is waiting for you in radio?*

New Course Offered by the
World's Oldest Radio School

After years of experience the Radio Institute of America has evolved a

new and revolutionary course in radio—right up to the minute and abreast of the most recent developments in the radio industry. It starts with the very fundamentals and takes you through every phase of radio—right through television—photoradiograms and airplane radio equipment.

The instruction is the work of radio experts and its clearness and simplicity are such that you can master every point with ease. You take examinations and your papers are corrected by men with years of radio experience. All your questions are answered and you are in contact with the Institute at all times.

Complete Kit of First-Quality Equipment at No Extra Cost

Our students must have the finest in equipment, so we furnish, at no extra cost, all the parts—first quality—to make many different radio circuits. We also furnish the Peerless Signagraph and other instruments for code instruction—at no extra cost.

Radio Institute of America
Sponsored by RCA, G-E
and Westinghouse

Conducted by the Radio Corporation of America and enjoying the advantages of RCA's associates, General Electric and Westinghouse, the Radio Institute of America is equipped to give—and does give—the finest radio instruction obtainable anywhere in the world.

Home Study Course

Moreover, you need not sacrifice your present employment, for you can study at home, when you please, and as long as you please. Thousands have successfully completed our Courses and advanced to important radio positions. Our new catalog, describing the course, is now ready. If you want to learn more about the profitable and fascinating profession of radio, send the coupon now for your copy.



Radio Institute of America,
Dept. A-10,
326 Broadway, New York City

Gentlemen:
Please send me your new catalog.
I want to know more about your
new radio course.

Name.....
Address.....
City..... State.....

RADIO INSTITUTE OF AMERICA

326 Broadway Dept. A-10 New York City

Enjoy LOUD SPEAKER OPERATION from a CRYSTAL

NO "TUBES" - NO "B" BATTERIES - NO COSTLY "ELIMINATORS" WITH THE SKINDERVIKEN TRANSMITTER UNIT

Simple microphone unit provides a most effective and inexpensive way to satisfactory speaker operation. Easy to build and operate circuit.



Everybody can do this now with a Skinderviken Transmitter Unit. The unit is fastened to the diaphragm of the speaker unit. It will act as a "microphonic relay." Every time an incoming signal actuates the diaphragm, the electrical resistance of the microphone unit will be varied correspondingly and the current from the battery, in series with it and the loud speaker, will fluctuate accordingly. Thus the problem of securing sufficient power to actuate the loud speaker is simply and adequately solved.

The results from this very novel and simple unit will astound you.

The expense of this hook-up is trifling compared to the elaborate tube circuits that give no greater actuation of the speaker.

Besides this there are many other valuable uses in Radio Circuits for this marvelous little unit. Every builder of Radio sets should have a few on hand.

LISTENING THROUGH WALLS

This Unit makes a highly sensitive detectaphone, the real thing—you listen through walls with ease. Plenty of fun and real detective work too.

CONDUCTING SOUND THROUGH WATER

Make yourself a miniature submarine signaling apparatus like those used during the war. Simple circuit with this microphone unit gives splendid results.

12-PAGE INSTRUCTION BOOKLET containing suggestions and diagrams for innumerable uses, furnished with each unit.

P. G. MICROPHONE TRANSFORMER

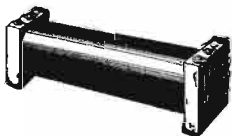

A Modulation Transformer specially designed for use with the Skinderviken Transmitter Unit. Has many other uses. Primary resistance, 1/2 ohm; secondary, 55 ohms. **\$2**

FOR SALE AT LEADING DEALERS

Or Order Direct, Using Coupon Below

SEND NO MONEY

When the postman delivers your order you pay him for whatever you have ordered, plus a few cents postage.

PRESS GUILD, INC. R-10-28
16-18-R—East 30th St., New York, N. Y.

Please mail me at once as many of the following items as I have indicated.

... Skinderviken Transmitter Units at 95c. for 1; \$1.75 for 2; \$2.50 for 3; \$3.20 for 4.

... P. G. Microphone Transformers at \$2.
When delivered I will pay the postman the cost of the items specified plus postage.

Name.....

Address.....

City..... State.....

socket designed for ordinary tubes, it presents the advantage that the physical separation of the plate circuit from those of the screen and (especially) of the control grid is rendered very much easier than in the case of the American tube.

One of the most interesting of the recent developments in French tube production is the so-called "plateless" tube. Needless to say, the plate exists *electrically*, being

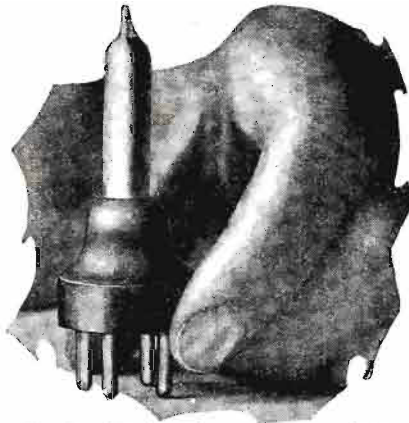

Fig. C. This is a picture of the new "plateless" tube now available to French experimenters.

formed by a metallic deposit (chiefly mercury) on the inside of the glass wall of the tube, to which contact is made.

The filament takes 0.06-ampere at 3.5 volts (the standard French filament voltage), and works with plate voltages about half those of the ordinary tubes. An internal resistance of from 25,000 to 40,000 ohms (according to type, the tube being produced in three types, for use as radio-frequency amplifier, detector, and audio-frequency amplifier, respectively) and an amplification constant of 12 to 15 are values given by the makers. The most striking feature is the practically complete absence of microphonic effects.

AMAZING STORY

In Our October Issue:

The Menace of Mars, by Clare Winger Harris. Most of our readers will note with pleasure this announcement of a new story by Mrs. Harris. In this tale, the structure of the atom and the analogy of the planetary systems of the universe thereto, and cosmic changes affecting the earth disastrously, are all treated in a most instructive manner.

The Voyage to Kemptonia, by E. M. Scott. Certain irregularities of our moon's motion have led some of our astronomers to believe that there is another body—small, to be sure—between the earth and the moon. Around the idea of this extra-terrestrial body is woven an absorbing tale of unusual interest.

The Skylark of Space. In the concluding chapters of this story, our author confines the travels of the Skylark to their newly discovered planet, the inhabitants of which seem to have made marvelous strides in mechanical science, but fall short of the advances in atomic theories and chemistry made by the Earth people.

To the Moon by Proxy, by J. Schlossel. The mechanical man, to most of us, seemed nothing more than a far-fetched dream only a short time ago. Yet today we have not only "the silent salesman" and "automatic change maker," but we actually have a mechanical man—a product of the Westinghouse Electric Company—who will start your vacuum carpet cleaner, answer your telephone, and do various other things, in response to the proper stimulus. The author conceives a creature of vastly more extraordinary abilities, and so gives us a most absorbing story.

Centralab Radio Control Box Protects "AC" Tubes from High Line Voltages

ELECTRIC Radio Sets using "AC" tubes are designed to operate on a line pressure of 110 volts. Any high voltage overloads the tubes and greatly shortens their life.

In many cities the normal line pressure runs from 120 to 135 volts. It nearly all cities the voltage fluctuates with the lighting load, and at some period during the day is high enough to damage the delicate tube filaments. That is why tubes lose their pep after short service and why the new Centralab Radio Control Box is an essential and economical accessory for most "AC" set owners.

The Centralab Radio Control Box is a manual line voltage control for "AC" sets. It can be adjusted for any set and for any local condition. It will protect radio tubes from high line voltage that would otherwise soon paralyze or burn them out. It insures longer tube life and better radio reception.

The Centralab Control Box is easily mounted within the cabinet. Adjustment is made by means of a knob, and when once set to obtain the average workable voltage need not be adjusted again. Connected as easily as placing a lamp into a wall socket. Furnished complete with receptacle and cord. No other wiring necessary.

Price \$3.00

At your dealer's, or write us.

CENTRAL RADIO LABORATORIES
19 Keefe Avenue Milwaukee, Wisconsin



Centralab

XL Products



Model N-1 Vario-Denser

Less Static

Sharper Tuning Bring Your Set to Maximum Sharpness

IN EVERY HIGH GRADE CIRCUIT TODAY

MODEL "N" VARIO-DENSER—Micrometer adjustment easily made, assures exact oscillation control. Quick, easy tuning, more volume, clearness and stability. Capacity range 1.8 to 20 micromicrofarads. Price \$1.00



Made in 3 variable capacity ranges; price, each, \$1.50. FREE Big new up-to-date book of wiring diagrams of all leading circuits. Write today for copy.

XL Radio Laboratories

Dept. A. 1224 Belmont Ave., Chicago, Ill.

FREE BOOK

New Hook-ups. This book shows how to make Short-Wave Receivers, and Short-Wave Adapters.

How to use the new screening tube in D.C. and A.C. circuits.

How to build Power Amplifiers, and ABC Eliminator. Up-to-the-minute information on all new radio developments.

Set Builders, Fans, Dealers, send for it today!



Write for it!

KARAS ELECTRIC COMPANY
4038-K N. Rockwell St., Chicago, Illinois
Please send me your Free Book!

Name.....

Address.....

City..... State.....

4038-K

THE NEW LEUTZ UNIVERSAL TRANSOCEANIC

9 TUBES

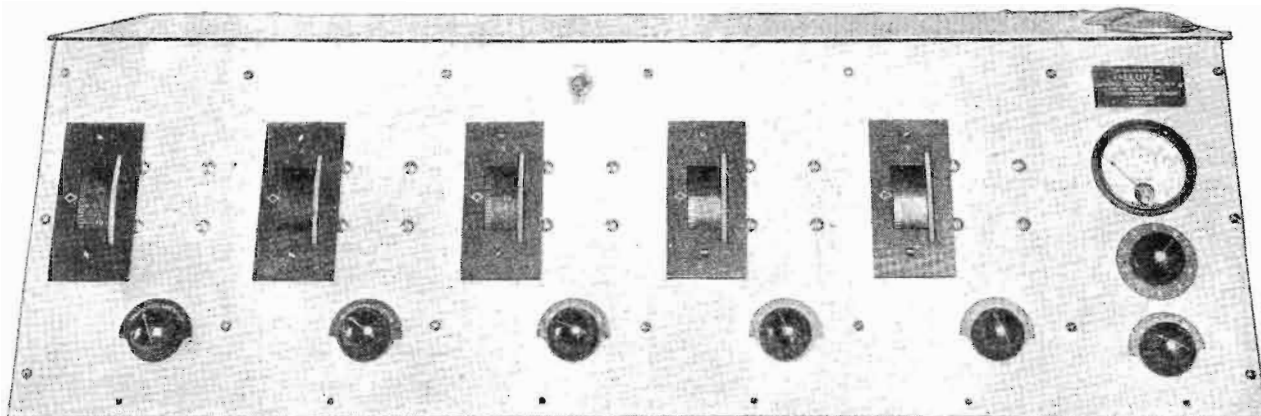

WITH FOUR UX222's AND 2—UX210's OR 2—UX250's

NEW IMPROVEMENTS

THE UNIVERSAL TRANSOCEANIC has now been completely redesigned to use the new 222 Screened Grid Tubes in the four stages of radio frequency amplification. The total radio frequency amplification is now approximately 810,000 compared with only 10,000 obtained with the 201A tubes. This allows increased receiving range, greater volume on distant signals, and without any loss in selectivity. The detector circuit has been altered to use the new 200A type detector.

The audio amplifier has been further improved, a total of four stages being employed, two of these stages in a

push - pull system. The push - pull power amplifier will take either two 210 or two 250 power tubes, the most powerful audio amplifier one could desire. The undistorted output available for the loud speaker is approximately five times greater than a receiver using only one 210 or 250 power tube.

The 400/500 Volt BC Current Supply has been changed to the full wave type, using two 281 rectifier tubes for increased output. Provision has been made to use a Dynamic speaker if desired. The addition of the Leutz "A" Current Supply having a capacity of 3 amperes at 6 volts makes the set available for all electric operation.

PRICE — COMPLETELY CONSTRUCTED AND LABORATORY TESTED — \$250
(NO ACCESSORIES)

Complete Constructional Blueprints—3 Large Sheets—\$2.00 Postpaid

A NEW RADIO BOOK for Custom Set Builders, Broadcast Listeners, Experimenters and Radio Engineers: "MODERN RADIO RECEPTION"—by Charles R. Leutz

PRICE — \$3.00 — POSTPAID

384 PAGES—OVER 250 ILLUSTRATIONS—FULLY BOUND—6 x 9 INCHES
Subject to refund if returned as unsatisfactory within 7 days

C. R. LEUTZ, INC.

195 PARK PLACE, LONG ISLAND CITY, NEW YORK

RADIO DIRECTORY



RADIO-LITE-TENNA

Write for details

AERIAL INS. CO.
GREEN BAY, WIS.

AMERICAN



Sub-Panel Brackets
Sub-panel brackets in various sizes ranging from 1" to 2 1/2" in height and from 7" to 11" in length. Cut illustrates No. 11. Write for literature.

American Radio Hardware Co.
Dept. 108, 135 Grand St.
New York, N. Y.

BAKELITE PANELS

MAHOAGANY or BLACK

7 x 18\$1.00	\$1.50
7 x 211.20	1.75
7 x 241.40	2.00
7 x 251.50	2.15

All Odd Sizes Cut to Order,
1/2¢ per Sq. In.

Mail Orders Filled Same Day
Send Money Order. Plus 15¢
for Postage

CENTURY RADIO PANEL CORP.
Now located at
67P Cortlandt St., New York
Telephone Rector 7468

BUILD THE NEW
Screen-Grid Hi-Q 29

Hammarlund
Roberts
CUSTOM-BUILT
Radio

A.C. and D.C. Models

Send 25c for
Construction Book
Hammarlund-Roberts, Inc.
1182 B'way, Dept. C, N. Y.

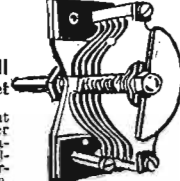

Cardwell Balancer

An efficient condenser for neutralizing, balancing, vernier, etc. It is also manufactured in dual model having two sets of stator plates which in operation give an increase on one side and corresponding decrease on other. Write for catalog.

Allen D. Cardwell Mfg. Corp.
81 Prospect St., Brooklyn, N. Y.



USE YOUR RADIO MORE!
Thousands of homes get more use of their radio because of the exceptional economy and dependability of our "B" and "AB" equipment. **WRITE!**

KIMLEY ELECTRIC CO.
441 East Ferry St.
Buffalo, N. Y.



HY-WATT

The Standard Resistances of Radio

El Menco radio products have become standards of quality and performance by sheer merit alone. Resistances of accurate and unchanging values. Write for literature on these and other products.

Electro-Motive Eng. Corp.
127 West 17th St., New York

VALLEY POWER UNITS



Dependable, Silent "B" Power Supply

Operates from 1 to 12 tubes. Designed for operation with all radio receivers. Toggle switch on panel controls lighting circuit. Amplifier and detector controlled by variable resistances. Silent, dependable and thoroughly efficient. Write.

VALLEY ELECTRIC CO.
St. Louis, Mo.



KLOBER SOCKETS, Type 125, 60c.
Genuine bakelite throughout. Absolutely shock-proof. Designed to give maximum efficiency permanently. Write for literature.

KLOBER RADIO CO.
1022 E. 178th St., New York, N. Y.

CABINETS

For Those Who Buy the Best Distinctive to say the least, are these exquisitely worked radio cabinets. Each one of the many styles, a masterpiece of the craftsman's art. Write for literature.

NEDMEL FURNITURE CO.
241 W. 36th St., New York City

O'NEIL Dynamics



The Speaker Hit of the Season

Two types—one for A.C. operation, the other for D.C. Equipped with our dynamic units. Beautiful two-tone walnut finish to match the popular sets. Write for literature.

O'NEIL MFG. CORP.
West New York, New Jersey



B. M. S.

The New Idea for a Radio Party

Lots of fun; fool your friends. Be your own broadcaster. Just plug the **Home Broadcaster** into detector socket of your radio and you can broadcast your voice just like the announcer. Write today for data.

Brooklyn Metal Stamping Corp.
718 Atlantic Ave., Brooklyn, N. Y.

Radio Hardware



Every type of terminal used in radio work, angles, lugs, ground clamps, bus bar strips—in fact everything to make set construction better and easier.

Write for literature

F. R. Zierick Machine Works
6 Howard St., New York, N. Y.



NA-ALD

parts for radio efficiency

Superior quality sockets designed for maximum efficiency—The Silencer Socket. Universal, and Na-aid Deluxe one of these is sure to meet your requirements. Write for literature on this and other Na-aid achievements.

ALDEN MANUFACTURING CO.
Springfield, Mass.



HAR-FIELD

WIRE-WOUND RESISTORS

FOR EVERY PURPOSE

There is a Harfield Resistor for every place that resistances are called for in radio. Write us and let us tell you about them.

HARDWICK-FIELD, INC.
122 Greenwich St., New York



BAKELITE and HARD RUBBER

DRILLING — ENGRAVING PUNCHING — STAMPING

Latest Circuit Panels in Stock. We cater to retail as well as manufacturing trade.

Cortlandt Panel Engraving Co.
165 Greenwich St., N. Y. C.

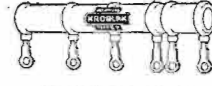

KROBLAK RESISTORS

For A, B, and C Eliminators

KROBLAK resistors never change their values, regardless of operating conditions. Write for literature, or ask your dealer to show this line to you.

C. E. MOUNTFORD
30 Sullivan St., New York



FAMOUS FAHNESTOCK CONNECTION CLIPS

Use them for appearance, positive contact, and durability. Write for catalog or pick them out at your nearest dealers.

FAHNESTOCK ELECTRIC CO.
Long Island City, New York

LINCOLN REVOLUTIONARY

A. F. Transformers

Designed by Kenneth H. Clough. Give 50% more undistorted amplification. Heavy bass frequency register. Marvelous tone quality. Specified in famous Lincoln 8-80 receiver. Write for information on Lincoln No. 105 first, and Lincoln No. 106 second Audio Transformers.

LINCOLN RADIO CORP.
329 S. Wood St., Chicago, Ill.



Sandar Speakers

Leaders by Popular Choice

Sandar low-tone quality reproduction has placed this line of speakers first in popular demand. Yellow reception over the entire musical scale. Write to us.

SANDAR CORPORATION
Long Island City - New York
Division of Farrand Mfg. Co., Inc.



NOPHONIC TUBE CAPS

Stop That Howl!

To get the best from your set, be sure that all tubes employ Nophon Tube Caps. Stops all vibration of the filament.

List Price..... 25c
Ask your dealer or write direct

MERTZ SPECIALTY CO.
1306 Stockton Street
Wilmington, Del.



WESTON INSTRUMENTS

WESTON INSTRUMENTS are precision instruments.

WESTON ELECTRICAL INSTRUMENT CORP.
589 Frelinghuysen Ave., Newark, N. J.

Pacent

PHONOVOX

THE ELECTRIC PICK-UP

Pacent Electric Co.
Inc.
91 7th Ave. New York

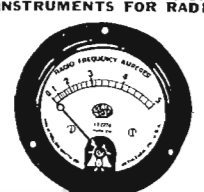

ROLLER-SMITH PRECISION INSTRUMENTS FOR RADIO

We manufacture an instrument for every need in radio. Send for bulletin.

ROLLER-SMITH COMPANY
2134 Woolworth Bldg., New York



PYREX

Radio's STANDARD Insulating Material

It's Insulation—be sure it's PYREX.

Write for descriptive book

Corning Glass Works
Corning, New York



VITALITONE

Life-liketone SPEAKER

Ask for literature

Reception so perfect that you will believe you are in the studio with the artists. Take no substitute. **INSIST on Vitalitones**

VITALITONE RADIO CORP.
88 University Pl., New York, N. Y.



Carborundum

THE LOGICAL DETECTOR

Bell-clear, Noiseless, Sensitive The Detector alone is suited for use in any set wired for a permanent crystal detector.

Write for literature.

CARBORUNDUM COMPANY
Niagara Falls, N. Y.

SAVE YOURSELF MONEY

SEND FOR OUR MONEY SAVING CATALOG Now

SET BUILDERS DEALERS!

Save money, time and bother by purchasing kits and parts from us. Maximum discounts to dealers. Latest kits and parts always in stock. Send NOW for catalog.

Wholesale Radio Service Co.
6R Church St. New York



RED LION

Cabinets

Authorized furniture for all Atwater Kents. Each design a work of art. Walnut finished; two-toned panels. Write for details and prices

Model illustrated, \$45.00

RED LION CABINET COMPANY
Red Lion - Pennsylvania



CORWICO

BRAIDITE

Hook-Up Wire

"The Braid Slides Back" Make your connection, solder it and the insulation slides right back into place. **SOLD BY ALL DEALERS** If yours can't supply you, order direct

25 Ft., .35c 25 Ft., .30c

CORNISH WIRE CO.
32 Church St., New York

The RADIO DIRECTORY is your buying guide. Space permits display of only one product at a time. Write advertisers for complete catalogue.

RADIO DIRECTORY

MAJESTIC CONE
Natural Tone
List Price \$12.50
YOUR PRICE \$2.25
Postpaid



Designed for use with or without power tubes

BIRNBACH
Moisture-Proof Extension Cords
Birnbach Extension Cords permit the Loud Speaker to be moved to any room in the house. Attaches instantly. Install a Birnbach Cord and put an end to distortion so often due to badly insulated cords. Your neighborhood dealer has these sizes in stock: 10-20-30-40-50-100 foot lengths. Send for Catalog.

BIRNBACH RADIO CO.
254 W. 31st St., New York

If you want more hours of service per tube, insist upon
PERRYMAN RADIO TUBES
"The tubes with the patented shock-proof bridge."
A tube for every radio purpose. All the A.C. types.
Write for literature.
Perryman Electric Co., Inc.
33 West 80th Street
New York City



RAMCO
Line of Radio Cabinets
Beautiful cabinets made by craftsmen to suit the taste of everyone. Model illustrated is known as our Type 1. American walnut imported overlays. Price \$36.50.
Write for literature
RADIO ALLIED MFRS. CORP.
1340 S. Michigan Av., Chicago, Ill.



B-L RECTIFIERS
Bone-Dry Noiseless, Durable Compact
B-L Rectifiers embody a new principle. They are adaptable to all types of electrical equipment requiring low voltage rectifiers. Write for further information.
THE BENWOOD-LINZE CO.
1832 Washington Avenue
St. Louis, Mo.



AMPLIFLEX LOOPS
Collapsible. Folding — Built-in Compass. List price, \$32.50; our price, \$2.79, postpaid. Write for Special Bargains now.
SPIEGEL RADIO COMPANY
135 Liberty St., New York City

THE B. B. L. MOTOR
An improved motor for loud speaker operation. Power without saturation. Eddy currents reduced to minimum. Permanent adjustment assures the highest quality tone reproduction.
Write for details
BEST MANUFACTURING CO.
1200 Grove St., Irvington, N. J.

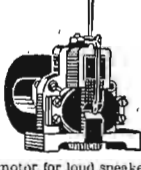

WEBSTER AU TO-POTENTIALATOR
A Webster product that instantly and automatically regulates local A.C. voltage, producing even supply of current best suited for operation of A.C. sets. Send for our catalog.
THE WEBSTER COMPANY
854 Blackhawk St., Chicago, Ill.



AIR-KING
The Ultimate in Precision Short-Wave, Plug-In Coils
Write for complete details and free instructions for building an efficient short-wave receiver.
AIR-KING PRODUCTS CO.
222-226 Grand Street
Brooklyn, N. Y.



GAVITT
EXTENSION CORDS
A fine, durable cord. Rubber insulated, twisted, and covered over all with high-grade mercerized braid.
Write for literature
GAVITT MFG. CO.
Brookfield - - Massachusetts



BACO VOLTAGE REDUCER
Equalizes A.C. voltages on the receiver. Saves the tubes from overstrain. Prolongs life. Install them for absolute protection.
Write for literature
BACO ENGINEERING CO.
1341 Flatbush Av., Brooklyn, N. Y.

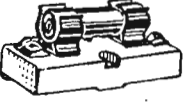

VICTOREEN RADIO PRODUCTS
The heart of the Super Heterodyne R. F. Transformers. Victoreen are matched Precision assures maximum results. Send for our catalog and full data on the Victoreen circuit.
THE GEO. W. WALKER CO.
2825 Chester Ave., Cleveland, O.



RADIO PARTS OF EXCELLENCE
A complete line of quality radio parts and tools. Sockets to accommodate all tubes. Beautifully designed dials and knobs. Binding posts, extension connectors; many other radio parts.
HOOSICK FALLS RADIO AND ELECTRICAL PARTS MFG. CO., INC.
Hoosick Falls, N. Y.



200,000
RADIO NEWS readers carefully scan the RADIO DIRECTORY every month. YOUR product here, at the lowest cost in the world's largest and most widely read radio magazine.
RATE CARD:
Three time rate.....\$25.00
Six time rate.....23.75
Twelve time rate.....22.50
No order for less than three insertions accepted.
Write for information.
Radio News, 230 5th Ave.

BODINE ELECTRIC TURNTABLE
Designed by experts for radio-phonograph combinations. Positively no interference in the loudspeaker. Write today for full information on this big new development.
BODINE ELECTRIC CO.
2242 West Ohio St., Chicago, I.



H. A. STILES
Beautiful Cabinets
Be sure and see our line of cabinets before you buy. Beautifully designed—beautifully made and beautifully finished. All standard sizes. Write for literature.
H. A. STILES & CO.
174 Portland St., Boston, Mass.



UTAH Exponential Horn
Illustration shows Series 1000—A very popular number for Phonograph Cabinets. Send for complete catalog of the various horns of this type that we manufacture.
UTAH RADIO PRODUCTS CO.
1615 S. Michigan Ave., Chicago, Ill.

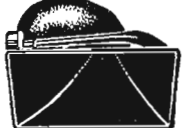

SMITHCRAFT WROUGHT IRON RADIO TABLES
B. H. SMITH SALES CO.,
755 Boylston St., Boston, Mass.



Arcturus Leads Again
The ARCTURUS type 22 was the first shielded-grid tube on the market. ARCTURUS not only leads in development, it leads in quality, also. Send for our catalog of Arcturus tubes—leaders, first, last, and always.
ARCTURUS RADIO COMPANY
Newark - - New Jersey



Ferranti
Transformers and Chokes for Every Purpose
The uniform high quality regular line—each one must come up to our rigid tests, instituted to insure their being of the highest quality. Read our literature before buying your next tubes.
FERRANTI, INC.
130 W. 42nd St., New York, N. Y.



HERALD Gothic Mantel Speaker
For Electric and Battery Sets
Handsome, compact, wonderful purity of tone. Equipped with new tone filter. Never rattles, regardless of the power behind it. Send for particulars
HERALD ELECTRIC CO.
29 East End Ave., New York, N. Y.



ERLA
SHIELDED GRID SEVEN
The World's Most Powerful Rectifier
A.C. operated. Extremely sensitive. Terrific amplification. Only two controls: one for tuning, the other for volume. Write for information and prices
Electrical Research Labs.
Chicago - Illinois



DE JUR VITREOUS ENAMELED POWER RESISTANCES
For "B" eliminators, power amplifiers and electric sets. These resistances are backed by 16 years of continuous, satisfactory service to the radio public. Write for catalog.
DE JUR PRODUCTS CO.
199 Lafayette St., New York, N. Y.



CONSOLIDATED CORPORATION'S
COMPLETE AERIAL KITS AND EQUIPMENT
Ask your dealer or write direct to
CONSOLIDATED CORPS.
Green and Congress Sts.
Chicago, Ill.

VOGUE NONPAREIL RADIO TUBES
Just the right tube for every radio use. Power tubes, A.C. tubes, the regular line—each one must come up to our rigid tests, instituted to insure their being of the highest quality. Read our literature before buying your next tubes.
ALLEN MFG. CO.
112 North Fifth St.
Harrison, N. J.



Silver-Marshall 660-171A UNIPAC
Supplies complete "A-B-C" Power. Contains built-in push-pull amplification stage requiring two 171A type power tubes. List Price Wired \$76.00 \$29.50 YOUR COST!
In Kit Form—Your Cost \$26.50 ALL NEW SEALED CARTONS.
RAUNER RADIO CO.
142 Liberty St., New York City



SONORA
ELECTRIC PHONOGRAPH MOTOR
For Radio-phonograph combinations. Absolutely no interference with programs. Made by specialists in phonograph equipment.
Send for full information
SONORA PHONOGRAPH CO.
50 West 57th St., New York, N. Y.

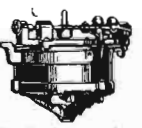

Stevens Speakers The Golden Voice of Radio
Stevens Speakers reproduce tones just as they come from the entertainers. Clear and accurate of the entire scale. Write.
STEVENS MFG. CORP.,
46 East Houston St., New York



NAME PLATES
WE SPECIALIZE IN NAME PLATES OF ALL VARIETIES: ETCHED PLATES, EMBOSSED PLATES, RADIO ESCUTCHEON PLATES.
Write for Samples and Prices.
ETCHED PRODUCTS CORP.
Queens Boulevard
LONG ISLAND CITY-N.Y.

REMLER
Interchangeable Inductances
Designed to be plugged into the standard UX socket. Equipped with easily removable and interchangeable primaries. Various primaries are available. Write for literature.
Gray & Danielson Mfg. Co., 260 First St., San Francisco, California.



SYLVANIA--TUBES OF EXTRAORDINARY MERIT
Maximum satisfaction and longer life—these are the high-lights of Sylvania Tube success. A tube for every use in radio. Write us today for literature on our superior radiotube line
SYLVANIA PRODUCTS CO.
Emporium - Pennsylvania



The RADIO DIRECTORY is your buying guide. Space permits display of only one product at a time. Write advertisers for complete catalogue.

WHOLESALE PRICES

for Dealers, Community Set Builders, General Repairmen and Agents!



Be sure to get this great 144-page book with net prices to the radio trade.

Radio Specialty Company is radio's oldest radio parts mail order house in the country, and the new confidential prices on standard radio merchandise are the lowest of any radio house.

We are ready now to appoint additional agents in all parts of the country. If you are contemplating making big money in radio merchandise, be sure to get in touch with us at once.

Television is here!

Radio Specialty, as usual, is first with all new things. Send at once for free booklet for lowest prices on all television parts which have been put on the market so far. (If you have Catalog No. 18, just ask for the Television Supplement.)

New 75 HOOKUPS
500 ILLUSTRATIONS

THIS 144 PAGE RADIO CATALOGUE FREE

BUY from Radio's Oldest Mail Order House!

We are the oldest established, exclusive radio mail order house in the country. All orders are positively shipped within twenty-four hours; quick, prompt, cour-

teous service. We carry a larger variety of radio parts, radio instruments, accessories and radio findings than any other radio house in the country.

You will find in Catalog No. 18 the largest assortment of radio merchandise in this country. Radio Specialty carries more radio parts and radio material than any other house in the country. You will find in this catalog positively the largest variety of radio merchandise.

If you are in need of certain small radio parts that other radio and mail order houses do not bother to carry get the Rasco Catalog and you will find the small parts there, anything from a screw to copper ribbon, telephone diaphragms, as well as thousands of other small radio findings. Just to mention a few:

Lugs, nuts, jacks, plugs, all kinds of knobs, cords, panels, screws, sliders, washers, selenium, tinfoil, switches, crystals, cap nuts, Litz wire, cord tips, brass rods, resistances, binding posts, switch parts, carbon balls, switch points, lock washers, carbon grains, ground clamps, metal pointers, insulate d tubing, low melting metal, antenna connectors, as well as thousands of other articles. We carry the Largest Variety of Small Radio Parts in the World, BUT We also carry All Standard Radio Merchandise.

"RASCO" has it

ANYTHING IN RADIO



Radio Specialty Co.



98W PARK PLACE, NEW YORK

Radio Free Blueprints Available

(Continued from page 319)

factorily in this manner, you can make it work a loud speaker by adding this simple two-tube amplifier to it. This amplifier will also work perfectly with any tuning system if it is connected after the first detector tube.

No. 56, "The Neutroheterodyne," June, 1928 number: This is a seven-tube super-heterodyne of advanced construction and design. Although we do not recommend it to the beginner, the man who has made one or two small sets and who is ready for something more ambitious will find this outfit very interesting. It is considerably cheaper and easier to make than most super-heterodynes, as the intermediate transformers can be wound at home and matched without trouble. Unlike most "supers," this receiver tunes with only single sets of dial readings, and not with double readings.

No. 59, "A Sturdy and Dependable 'B' Power Unit," July, 1928, number: This is a husky "B" socket-power unit, designed especially for the Neutroheterodyne, but which will work equally well with practically any other receiver. It provides a maximum of 350 volts for the operation of a 210-type power tube and has enough capacity for a ten-tube receiver.

No. 57, "A Crystal Set," July, 1928 number: This is the very simplest possible radio receiver that can be made for the actual reception of signals from broadcast stations. The whole thing is only six inches square and three inches deep and can be assembled at a cost of less than \$2.00. It uses neither tubes nor batteries, but will bring in stations up to 25 or 30 miles away. It can be assembled in an evening by any intelligent 12-year-old boy.

No. 58, "A 'Junk Box' Short-Wave Receiver," July, 1928 number: This is one of the most popular receivers Radio News has ever described. It is a simple two-tube affair assembled on a small board, and uses parts that practically every experimenter can find in his junk box. With four plug-in coils wound on tube bases, it covers the short-wave channels from 20 to 100 meters. Hundreds of people who have built this set have heard short-wave broadcast stations in many parts of the world.

No. 60, "A Two-Tube Reflex Set of Simple Design," August, 1928 number: Another good set for the beginner. It uses two tubes, but gives the results that about 3½ tubes would give in an ordinary circuit.

No. 61, "A Booster Unit for the Browning Drake," August, 1928 number: The original Browning Drake uses only one stage of tuned radio-frequency amplification. If you own one of these receivers and want to increase its sensitivity and selectivity, make up this simple booster and hear more DX.

No. 62, "A Screen-Grid Short-Wave Receiver," August, 1928 number: Most short-wave receivers use a simple regenerative circuit. This one has an additional radio-frequency amplifying stage which makes the reception of distant short-wave broadcast stations more reliable. It has only one tuning control and does not require complicated shielding. It is an inexpensive, easily-constructed set that will work without trouble.

No. 63, "The Screen-Grid Stroboddyne," September, 1928 number: This fine set has

Your Present Radio

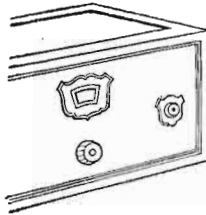

... can be made an Electric A.C. Set *without changes in wiring or even the cost of new tubes*



Kuprox A.C. Power Pack. Makes any battery set an electric A.C. receiver. \$32.50 up.



Kuprox Multi-rate Rectifier, for trickle charging, dynamic speaker operation, etc. \$11.50



Kuprox Replacement Unit eliminates acids, liquids, bulbs from trickle chargers \$5.00

THERE'S no necessity for discarding a good battery operated receiver to get the convenience of A.C. operation. The Kuprox A.C. Power Pack converts any good set into an electric A.C. set, without changes of any kind in wiring, without the use of harnesses or adaptors.

Kuprox equipped, your present set, using your present tubes will give you super-fine A.C. operation. Everything your radio did before, it will do even better. And there's nothing to bother about... the entire set turns on and off at your light socket. The Kuprox A.C. Power Pack is a permanent addition to your set that will double your radio enjoyment.

Several models are offered. One that supplies all radio power for any size set. Or separate filament and plate models for those who desire this form. And an efficient "A" model that supplies filament current and will operate in conjunction with any good "B" eliminator. Priced from \$32.50 up. See the various models at your radio dealer's. Or, if you first desire more information, we'll be glad to send it if you will write.

THE KODEL ELECTRIC & MFG. CO.
Formerly The Kodel Radio Corp.

501 E. Pearl St. . . Cincinnati, Ohio

KUPROX

A.C. POWER PACK

Please say you saw it in RADIO NEWS

A Good Antenna System will improve Your Radio Set!

Few set owners realize how important it is to have a good antenna system. An old, corroded antenna picks up very little energy from broadcasting stations, and the receiver cannot work properly. A Belden Aerial Kit assures an antenna system of high efficiency. Furthermore, it is permanent, because a Belden Aerial cannot corrode.

Bare Copper Aerial Wire Corrodes Rapidly

Belden Aerial Wire is protected against corrosion

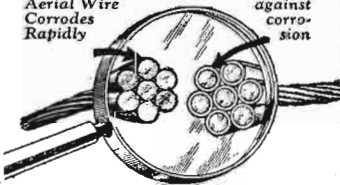

Other Belden Radio Products

Indoor Aerial Kits, Colorubber Hookup Wire, Aerial Accessories, Battery Cords, Extension Cords and many other items are included in the Belden Line.

Ask your dealer to show you the New Belden Loudspeaker Extension Cord that is flat and lies under the rug. No unsightly wiring around the room. Does not wear the rug.

Belden Manufacturing Co.
2314-A S. Western Ave. - Chicago



Belden

been acclaimed the most sensitive one of the year. It is an improvement over the original Strobodync, which was described in RADIO NEWS last summer and which has achieved world-wide fame. The large blueprints show every detail of the interesting construction.

The three latest blueprints are listed elsewhere in this number of RADIO NEWS. They show the construction of a completely shielded short-wave receiver, a simple screen-grid set for the beginner, and a combination broadcast and short-wave outfit.

Please remember to write your name and address clearly, and to state specifically what blueprints you want.

Reception in a Draped Room is More Pleasant

A ROOM which is generously furnished with rugs, stuffed furniture and curtains or other draperies usually has better acoustical properties than one which is comparatively bare; and it, therefore, can be expected to make the radio reproduction sound better to the listener's ears. In a bare room the sound produced by the loud speaker tends to develop echoes, which sometimes completely spoil the performance of the set.

Treatment of a Baseboard

IF you plan to use a wooden baseboard as a permanent part of a radio receiver, it is a good idea to give it two or three coats of shellac or varnish before mounting any instruments on it. It will then be less susceptible to warping than if it were left uncoated.

PENETRATING RADIATION

When Dr. Brown's X-ray machine Made static in our block
The neighbors lost their patience and The patients lost their Doc.
—Helmert Huebner

40 Non-Technical Radio Articles

every month for the beginner, the layman and those who like radio from the non-technical side.

SCIENCE AND INVENTION, which can be bought at any newsstand, contains the largest and most interesting section of radio articles of any non-radio magazine in existence.

Plenty of "How to Make It" radio articles and plenty of simplified hook-ups for the layman and experimenter. The radio section of SCIENCE AND INVENTION is so good that many RADIO NEWS readers buy it solely for this feature.

Radio Articles Appearing in October Science and Invention Magazine

- AUTOMATIC TUNING FOR THE RECEIVER
- BUILDING A PARROT LOUD SPEAKER
- NEW RADIO DEVICES
- RADIO WRINKLES
- RADIO ORACLE
- LATEST PATENTS

MASTER VOLTAGE CONTROL

This voltage regulator (patent pending) is a necessity on all A-C sets. It protects A-C tubes from burning out by reducing excessive line voltage to the proper value. Anyone can install it. Requires no guesswork in setting for the proper voltage. Has no moving parts, therefore nothing to wear out or get out of adjustment.

NO TOOLS NECESSARY

Simply call up the power company in your district and ascertain the maximum line voltage. Plug your A-C set into the MASTER VOLTAGE CONTROL to correspond to that line voltage. These various line voltages are clearly indicated so that the proper setting may be had. No voltmeters, no tools or a service man's time is required for installation. Once installed it requires no further attention. To get proper life out of A-C tubes and keep them from burning out use a MASTER VOLTAGE CONTROL.



PRICE \$2.50

At your dealers or write us.

MASTER ENGINEERING CO.

Dept. 827-N

124 South Michigan Ave., Chicago, U. S. A.

CARTER

A New Principle in RESISTORS

Steel Tube—Vitroous Enamel

New steel construction makes them unbreakable. Dissipate more heat. Lighter in weight. Terminals will not become loose. Carter again leads with this new product.

MEMBER RMA
Carter Radio Co.
CHICAGO

Newest Information TO SET BUILDERS

LATEST RADIO GUIDE

Elections, football games, big National events will boost radio business this year. Set builders will reap a rich harvest. Barawik service will make you money. Everything in A-C sets, parts, supplies. World's largest radio stocks on hand. Orders shipped same day. Lowest rock-bottom wholesale prices.

Mail coupon for free Radio Catalog now
BARAWIK CO. 130E Canal St., CHICAGO, U. S. A.
Mail this coupon for Free Radio Guide

Name _____
Address _____

We Unconditionally guarantee

The LOFTIN-WHITE JEWELL and MIESSNER

A-C "R-P-L" Receiver

to be the

World's Greatest

RADIO BROADCAST RECEIVER

REGARDLESS OF PRICE

*Sold Only Through Authorized Representatives,
Complete or in Unit Form*

SPECIFICATIONS

**THESE SPECIFICATIONS MEAN SOMETHING TO ANYONE
WHO KNOWS ANYTHING ABOUT RADIO**

Three stages of Loftin-White constant coupled tuned radio frequency amplification, giving practically a straight-line amplification factor over the entire broadcast wave band. Giving 10,000 cycle separation, and due to new design of coupling in each stage it has an unusual sensitivity factor. True single dial operation with tuned antenna input and full range volume control. Automatically adjusted below the point of oscillation. Non-regenerative detector feeding the audio amplifier that has an amplification factor of over 750, which is from three to five times greater than any commercial types that are now on the market. Two stages of Jewell Dual Impedance audio amplification, assuring straight line amplification over the entire band of audible frequencies, feeding into a 250-power tube that has an undistorted output of over 500 milli watts. This amount of power is capable of overloading any of the commercial loud speakers now on the market. In other words, nothing has been left out in the engineering of the receiver that could be desired by the most discriminating radio critic, and also due to the fact that the Miessner system of A.C. operation is employed the A.C. hum is reduced to an absolute minimum.

Mr. Radio Fan and Professional Set Builder!

Why not capitalize the prestige and distinction that goes with being our local representative in your territory by selling the most remarkable radio receiver that has ever been offered to the American public? This receiver was designed and engineered by the most prominent radio engineers in the world today. Write us NOW for our EXCLUSIVE REPRESENTATIVE PLAN.

Unconditional Guarantee---You Being the Judge

We unconditionally guarantee this receiver to be the best radio broadcast receiver that can be built under the present known theories of the science and if, for any reason, it does not come up to your every expectation, it may be returned to us, in good condition, any time within thirty days and your money will be refunded in full.

RADIO PRODUCTS LABORATORY

F. A. JEWELL—GENERAL MANAGER

1931 BROADWAY - - NEW YORK, N. Y.

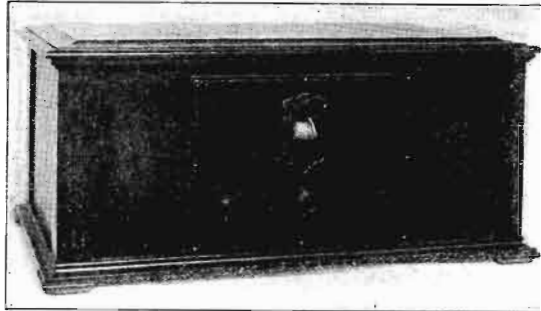

PROVISION IS MADE FOR ELECTRIC PHONOGRAPH PICKUP

Manufactured Under Loftin-White Jewell and Miessner Licenses

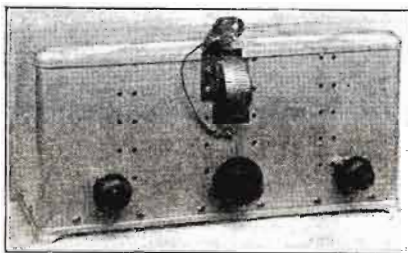

LOFTIN-WHITE TUNER

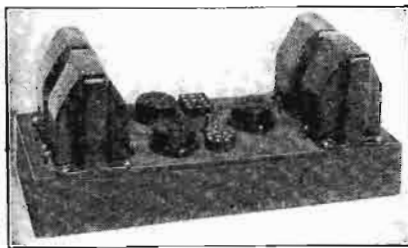

JEWELL DUAL IMPEDANCE POWER AMPLIFIER

Distributors for Loftin-White Tuner R. F. Amplifier, Jewell Audio Amplifier, CeCo Tubes, Airchrome, and Jensen Loud Speakers

FIELD REPRESENTATIVES WANTED

RADIO PRODUCTS LABORATORY
1931 Broadway, New York, N. Y.

Gentlemen: Kindly send me, without obligation your Field Representative Plan.

Name.....

Address.....

City.....State.....

Laboratory Takes Wings

(Continued from page 301)

at 2:00 P.M., en route for Dayton. Communication was maintained between Bolling Field and the airplane until Burgess Field was reached, where we landed. The last one-half hour schedule was interrupted due to a "short" in the keying circuit in the airplane transmitter, but signals from the Bolling Field station were as audible at Uniontown as throughout the trip. Upon taking off at Burgess Field a short schedule was worked with WYI at that station by telephone. As the beacon from Dayton was laid on the Uniontown-Dayton course, WYI was asked to stand by while the airplane worked Dayton by phone. Telephone communication was established before reaching Wheeling and maintained until landing at 6:45.

ARMY SETS SUCCESSFUL

"This trip has amply demonstrated that the SCR-134 can work far in excess of its conservative rating. The experimental double-voltage engine-driven generator functioned perfectly throughout the 22-hour flight. This type of generator used somewhat in excess of the power requirement for the SCR-134, and will be used for the long-range bomber sets now under development. The adoption of this generator will lighten the power load on the bomber, over the SCR-135 power installation, approximately 190 pounds and will displace power equipment and other apparatus at a saving of approximately \$600.00 per bomber. A similar type generator for observation planes will reduce the observation load approximately 50 pounds, and displace equipment costing approximately \$100.00. A similar generator will eliminate the need for batteries on pursuit planes and will lighten the pursuit load considerably by the displacement of dynamotor and battery.

"With the facilities for directly comparing various types of apparatus in the airplane during flight, and for making repairs and changes on apparatus during flight, the C-2 airplane has more than paid for itself, even in the limited time that it has been in commission as a flying radio laboratory. Considerable data have been obtained on short-wave propagation during the day, and this type of airplane, due to its navigation and power equipment, will make it possible to safely and economically conduct long-range night radio and navigation experiments."

PRIVATE EXPERIMENT

Radio airplane experiments of extensive nature are now also being conducted by the Pilot Electric Mfg. Company, of Brooklyn, New York, under the supervision of its research engineer, Milton B. Sleeper. For this work a specially-constructed six-passenger Stinson-Detroit monoplaner is being used, the various experimental transmitters of the plane operating under the call letters 2XBQ. A portable ground station with the call letters 2XBP, erected at Curtiss Field, Long Island, is also on the air frequently. Pictures of this plane appear on page 301.

The metal "fuselage" of the plane is bonded together to form a low-resistance electrical path, to be used as a "counterpoise," or artificial ground. The ignition system is thoroughly grounded to prevent spark interference. Details of the interesting work being done with this plane will be published in a forthcoming number of RADIO NEWS.

Enjoying Fan Confidence

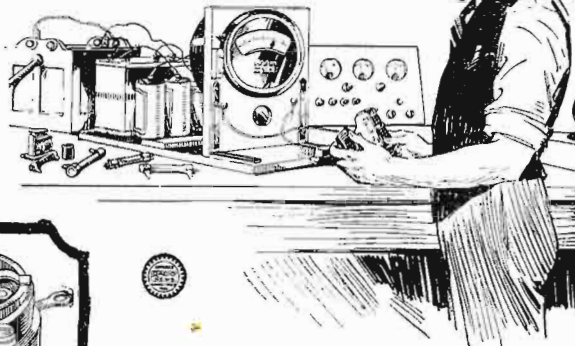

TONATROL

Trade mark

A Complete Line of Volume Controls

Concerts, sporting events, speeches, jazz—how much better they come in if your volume is just right! Tonatrol enables you to control volume smoothly and adapt it to each occasion. There are types designed expressly for your circuit, whether it's battery or A.C. Can be had with filament switch or power switch attached—\$1.50 to \$3.00.

TRUVOLT

Reg. U. S. Pat. Off.

ALL-WIRE RESISTANCES

The ideal variable, fixed, and tapped voltage controls. Truvolt Variables simplify B-Eliminator construction by eliminating difficult calculation and making all adjustments easy. 22 Stock Types—\$3.50 each. Truvolt Fixed Resistances are adjustable to different set values by the use of sliding clip taps—an exclusive Truvolt feature! Made in all desirable resistance values and current ratings.

Electrad specializes in a full line of Controls for all Radio Purposes

-CUT HERE-

ELECTRAD, INC., Dept. N-10, 175 Varick St., New York, N. Y.
 Please send me descriptive circulars on the following products and put me on your mailing list for similar literature.
 ... General Circular; ... Tonatrol Volume Controls; ... Phasatrols; ... Royalty Variable Resistors; ... Truvolt Divider; ... "Electrad Control Manual" (enclose 10c. for mailing); ... "What Eliminator Shall I Build?" (enclose 10c. for mailing).
 I am particularly interested in
 Name
 Address

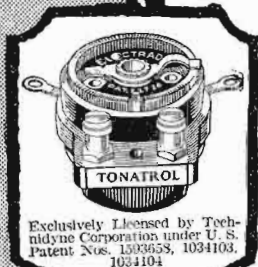

Exclusively Licensed by Technidyne Corporation under U. S. Patent Nos. 1,593,553, 1,034,103, 1,034,104

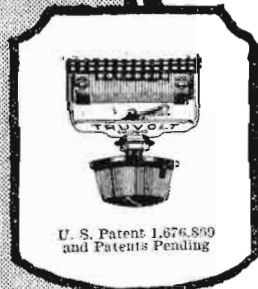

U. S. Patent 1,876,899 and Patents Pending

ELECTRAD Inc.

DEPENDABLE "B" BATTERY POWER

100 Volt Edison Element.
 Non Destructive, Rechargeable "B" Battery with charger. Shipped dry with solution. \$12. 140 Volt with charger. \$17. 180 Volt Power Unit with Trickle Charger. \$24.00. Free sample cell. See how it operates.
SEND NO MONEY—PAY EXPRESSMAN
 Write for our Free Illustrated 24-page Booklet
SEE JAY BATTERY CO., 915 Brook Ave., New York

HOOK-UP BOOK FREE

Improve your reception with
CARBORUNDUM
 Stabilizing Detector Units,
 Grid Leaks and Resistors
THE CARBORUNDUM COMPANY
 DEPT. D-1, NIAGARA FALLS, N. Y.

More Profits To Set Builders

One good radio idea may be worth millions. Barawik has thousands of ideas for radio set builders to make more money. **Barawik's Big Radio Book** will help you while elections are on and big national events stir the world.
 Send for your copy today - NOW.
BARAWIK CO. 210 Canal Station, CHICAGO, U. S. A.

PEP UP YOUR SET!

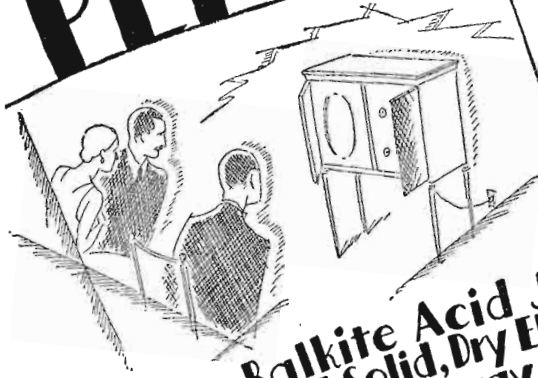

Replace your Balkite Acid Jar with the Authorized Solid, Dry ELKON Replacement Unit. . . Get away from Acids, Water, Corrosion, Trouble. . .



BUY ELKON—The Authorized Replacement Unit
Throw away the acid jar! No more fuss, mess, trouble. Simply remove the Acid Jar and snap in the Elkon Replacement Unit—Solid—dry—self healing—no attention or adjustments, and forget it for 5000 hours.
The Elkon Replacement Units and those made by the Fansteel Power Units are the only ones authorized for replacing the acid jars in Balkite Power Units.
With the Elkon Self-Healing Replacement Rectifiers, your type K will charge at the rate of .8 ampere, type N at the rate of 1 ampere. The charging rate of type J the large charger, is raised 20%. Increased efficiency, too! Why not see your dealer today!

ELKON, INC.
Port Chester, N. Y.
Division of P. R. Mallory & Co., Inc.

This is just one of the many reasons why Elkon Replacement Units are authorized by Fansteel—Accurate, careful testing of every Rectifier.



Perhaps you need a New Elkon Rectifier

If your set hasn't the same pep and kick it did when you first installed your "A" Eliminator, you need a new Rectifier in the "A" Eliminator. And you are lucky if you have a Majestic, Elkon, Knapp, Fada, Sentinel, Webster, Metro and many others for then you can slip the old rectifier off, and put in a new Elkon Replacement Rectifier in less time than it takes to read this. And the old eliminator is as good as it ever was! Buy one today from your dealer.

If your trickle charger isn't keeping the battery up as well as it did when you bought it—buy a set of Elkon replacement rectifiers and it will be as good as it ever was. Elkon Type V-4 replacement Units can be placed in Acme, Elkon, National, Cleveland, Precision, Bernard. Today's a mighty good time to pep up the old charger—see your dealer.

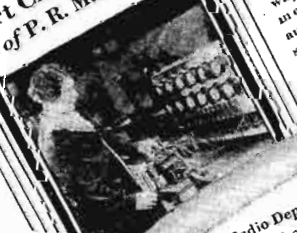

Radio Department,
Elkon, Inc., Port Chester, N. Y.
280 Fox Island Road.
Send me complete information on Elkon Radio Products.
Name.....
Address.....

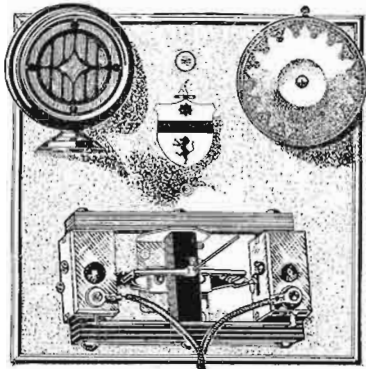

Mozart-Radioceiver Speakers and Speaker Units FOR SEASON 1928-9

MERIT, and merit alone, will sell and keep sold a loud speaker unit in a discriminating market where the continual craze is for better and better performance. Hence the only reason for the Radioceiver Twin Armature (double motor) speaker unit again far outselling all others in its class during the past summer season to New York City fans.

Here indeed is still the last word in a Super-Sensitive unit for operating almost any type of diaphragm with minimum current consumption and at voltages all the way from 90 to 400.

Or where a complete Speaker is required our Mozart Wall-Cones or Drum type fitted with this unit are still guaranteed on a money-back basis, to excel in appearance and performance all others in the market at anything approaching their prices.

- Twin Armature (double motor) Speaker Unit complete with Cord \$ 6.00
- 26" Wall Cone Speaker complete with Twin Unit 8.00
- 36" Wall Cone Speaker complete with Twin Unit 10.00
- Drum Type Speaker complete with Twin Unit 12.00

THE FERGUS CO.
239 ELIZABETH AVENUE
NEWARK, N. J.

**This Catalog Will
Save You Time
and Money**

Write today for our large illustrated new Catalog "B," showing how this organization of men with years of experience in Radio can give you personal service.

**Allied Radio
CORPORATION**
711 W. LAKE STREET, CHICAGO

6 TUBE SUPERPHONIC RADIO—\$16.95

FREE—Six tubes, tested and matched.
An amazing value that can't be beat! Latest 6-tube tuned radio frequency circuit. Metal chassis, shielded. Extremely selective. Long-distance reception. Send for complete descriptive circular. Value \$60, our price \$16.95. Write today. Radio Equipment Co., D. 12K, 545 S. Wells St., Chicago, Ill.

The Photoelectric Cell— Radio's "Eye"

(Continued from page 307)

small currents in the cell. Thus the shading of the object is translated into an electric current of varying magnitude.

The application to the talking movies is extremely simple in principle. Sound, as you know, consists of vibrations of the air. Each pitch has a definite frequency that is a definite number of vibrations per second. Sounds are recorded on a strip of film, along one side of which little wavy lines represent individual sound vibrations. When this film is run at the customary speed, a certain number of these lines pass a given point in each second. Where they are closely spaced, of course, more pass than where the spacing is greater. A narrow beam of light is passed through this film into a small photoelectric cell in back of it. Where there are no wavy lines, the intensity of the light beam remains constant and, consequently, the current through the cell stays constant. When the little lines move across the light beam, however, they cut off the light a definite number of times per second. This means that the photoelectric-cell current decreases and increases again the same number of times per second. If this current is passed through a telephone receiver a note will result, having its pitch corresponding to that number of vibrations per second, and in this way musical sounds or speech can be reproduced.

AUTOMATIC INSPECTORS

Another application of the photoelectric cell has been to the sorting of cigars. After manufacture, cigars must be sorted into various grades, depending upon their relative degree of lightness or darkness. Formerly this was done by eye. Now the cigars pass on a conveyor before a photoelectric cell, and a beam of light directed on the cigar is reflected into the cell. The lighter the cigar, the more light is reflected into the cell, and the larger will be the current in the cell circuit. Cigars are separated into a number of different groups, according to their shades, by the action of selective relays operated by the photoelectric currents which cause the cigars to be dropped into the proper bin. (See the article, "A Photoelectric Bean Sorter, on page 318 of this issue.—EDITOR.)

A rather similar principle is made use of in a photoelectric cell device for testing breakfast foods. The corn flakes come out of the oven on a conveyor and pass beneath a photo cell. If they are overdone, they are dark in color and little light is reflected into the cell; while if they are underdone, more light passes into the cell. In the first case the cell current is comparatively small and in the second large. The cell current is used to operate relays which control the furnace temperature.

Another interesting application is the automatic recording of daylight. The cell is exposed to diffused daylight and the cell current is passed through a recording meter. The meter records on a strip of paper the variations in current which are, of course, proportional to the variations in daylight intensity.

Another application is to the control of street or sign lighting. When the light intensity drops below a definite value, the

LYNCH TELEVISION Amplifier Kit



WITH this precision-built kit you can assemble at minimum trouble and expense an efficient amplifier for securing quality reproduction in your television reception apparatus.

The audio amplifier is an extremely important part of television receivers. Where the signal to be received contains frequencies of from 18 to 20,000 cycles, the audio amplifier must be able to amplify all frequencies within these limits. Such an amplifier is available at your dealer in the Lynch resistance coupled amplifier kit.

Your dealer has a Lynch precision-built resistor for every resistance need. Send for free book.

ARTHUR H. LYNCH, INC.
General Motors Building
1775 Broadway, at 57th Street
New York, N. Y.

Your Set Can Now Get Short Waves

Send anywhere in the U. S. post paid upon receipt of price. Canada and Foreign, 50c additional. Money order only. Also sent C. O. D. plus postage in U. S. if \$1.00 accompanies order to insure carrying charges. In ordering be sure to name set and tubes used, such as UV195, UX199, WD11, 201A, UX226 or UY227. Price \$15.00 or \$17.50 for A. C. Sets.



The SUBMARINER

will convert your regular set into a short-wave receiver by simply inserting a plug in place of one of the tubes. This takes but a few seconds. With "Submariner" it will enable you to tune between 26 and 68 meters.

This device operates with all sets, such as T. R. F., Nonodyne, Super-Heterodyne and others A C or D C operated. No additional tubes, batteries, or coils required. If set operates a speaker it will go so with "Submariner" attached. Operates as a wave changer with Super-Heterodyne and as detector unit with others.

SHORT-WAVE RECEPTION

is practical, and especially in summer, as they penetrate better and there is less static. The "Submariner" waveband includes practically All Powerful Stations Which Broadcast Programs. You may also listen to amateurs from all parts of the world who transmit code messages. You will have one of the most efficient short-wave receivers when the "Submariner" is attached to your set. Get a "Submariner" so you may have command of the short-wave activities as well as the broadcast band. If your Dealer does not carry

ORDER TODAY DIRECT

This device has been nationally advertised, and sold in all parts of the world for the past two years

J. M. P. MANUFACTURING CO., INC.
Department 53 Millwaukee, Wis., U. S. A.

\$1 SAVES YOUR SPEAKER

The CRAFTSMAN Dollar Speaker Filter is guaranteed to relieve speaker of plain D.C. (189 to 250 volts). Complete Protection. One Dollar Postpaid.

CRAFTSMAN RADIO PRODUCTS
9 Orchard St., Newark, N. J.



current through the cell also drops proportionately; and it can be made to operate a relay which will switch on the lights.

These are a few of the applications of the photoelectric cell. It has great possibilities for any work in which light plays a part, and I believe that, once its characteristics are understood by engineers, it will find as many uses as has that other member of the vacuum tube family, the radio tube.

How to Build from the Schematic

(Continued from page 323)

available to him in the pages of RADIO NEWS, to be consulted when necessary. He knows the precautions to be taken in running his leads and in the use of shielding, when he introduces it into his construction. He reads the schematic circuit as a plan which allows him considerable latitude in his selection of material, so long as its electrical effects are properly proportioned. In other words, the schematic diagram is his servant; while for the neophyte the pictorial diagram is a master who must be obeyed literally.

Lengths of Flexible Wire Useful in Experimenting

ORDINARY flexible lamp cord, which is the equivalent of No. 18 wire, is very convenient for temporary connections in experimental work. It is a good idea to cut up a dozen or so pieces of different lengths (one foot to three feet) and equip their ends with clips. Quick connections can then be made with these wires without the necessity for soldering or for the use of pliers.

The Humorists Begin Worrying for Us



"When the latest television invention is attached to our telephones, we shall be able to see the person we are speaking to—"



—but no invention has yet been discovered that entirely eliminates the possibility of being suddenly switched on to a wrong number!"
—"London Opinion."

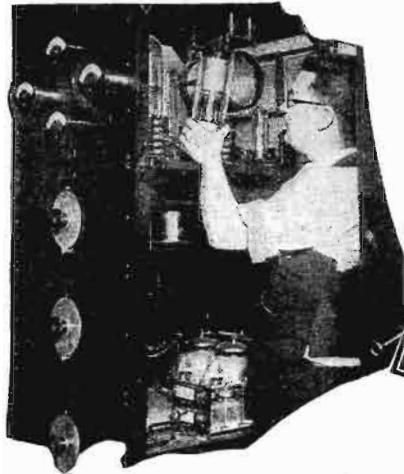

FREE RADIO BOOK~ describes many opportunities to make big money in the Radio field.

Here's a book that's shown man after man the way to "cash in" on the big opportunities in Radio. I'm not asking \$5 or \$6 for this book—it's FREE. If you're earning a penny less than \$50 a week clip the coupon below and get a copy of this free Radio book for yourself.

Salaries of \$50 All the Way Up to \$250 Weekly Not Unusual

Radio—the NEW, speedy, growing, live-wire profession—needs trained men for its good jobs. Television, trans-Atlantic Radio telephony, many other wonderful inventions and developments are being made constantly in this field! Each one means more big-money opportunities for a trained Radio man. My book gives the facts about these Radio opportunities. And more—it tells how you can get all the training in Radio you need, quickly and easily in your spare hours at home, by my new and practical methods. In a short time you, too, as have hundreds of others, can be prepared to take advantage of these big-money Radio opportunities—salaries of \$50 all the way up to \$250 a week not unusual. My Free Book will give you all the Facts and Proof.

Extra Dollars for You Almost At Once

Think of making \$15, \$20, \$30 extra each week "on the side," without interfering with your regular job! I'll show you how to do that, too, by using spare time that you're wasting now. I'll show you how to turn what I'm teaching you into cash almost at once, when you and I get started together. My Free Book tells you all about it. If you send for the book today, and if you have the average man's ability, it's possible for you to be making extra money thirty days from now. And you'll be ready for a good full-time Radio position after eight to twelve months' of spare-time training.

I'll Send You this Big 64-Page Book FREE

My book is filled with photos and facts—the paying facts you want to read. If you're interested in Radio, or if you're interested in making more money, you owe it to yourself to read this book. The book absolutely won't cost you a cent, and you place yourself under no obligation by sending for it.

No previous Radio experience needed to take advantage of this offer. No special schooling required. Send coupon today.



J. E. Smith

Address J. E. SMITH, President
National Radio Institute, Dept. 22SS, Washington, D. C.

J. E. SMITH, President,
National Radio Institute,
Dept. 22SS, Washington, D. C.

Dear Mr. Smith: Kindly send me your free 64-page Radio book, with all information about learning Radio for bigger pay. I understand this places me under no obligation.

Name.....

Address.....

Town..... State.....

HUNDREDS OF MEN HAVE WON SUCCESS THIS WAY
The National Radio Institute is the oldest and largest Radio home-study school in the world. It has prepared hundreds of men for the Radio profession—some of them now holding leading positions in this industry. You'll find N.R.I.-trained men in practically every Radio organization of any importance throughout the world. The same practical tested training that enabled these men to get ahead is now open to you. And this training has been improved, enlarged greatly to keep up with the constant expansion of Radio opportunities.

Executive with Big Corporation
"Am now Secretary and Treasurer of the Hammarlund-Roberts organization. My success here and in my former position as Editor of Radio Home due to the splendid training I got from you."—Leslie G. Biles, 1182 Broadway, New York City. **Earns \$1000 by Spare Time Work**

"In spare time in the evening I have made about \$1000 since starting your course. I am going right ahead with the lessons and work hard, for Radio sure is a field of unlimited opportunity."—Deloss Brown, South St., Foxboro, Mass. **From Miner to Over \$5000 Yearly**

"Two years ago I enrolled for your training—a coal miner by trade. Now I'm manager for the entire state of Michigan for the National Lead Battery Co., salary \$3480, bonus \$360, and commission, on sales that boosts it over \$5000. Your training gets all the credit."—Wm. H. Wilson, 1429 S. Michigan Ave., Chicago, Ill.

Mail coupon Today!

Now— TELEVISION —and the accepted motor for it!

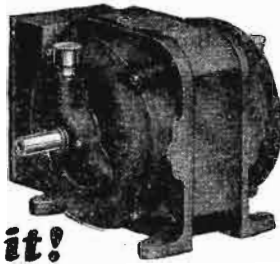

ON JUNE FOURTH through Station WLEX, Lexington, Mass., before a gathering of business and engineering leaders of the radio industry, a very successful demonstration of Television was held. The images were sent over the air and accurately received without the noise that had previously accompanied earlier experiments. The Baldor Motor illustrated above was responsible for the success of the Television demonstration. Many motors were tested but the Baldor Single Phase Motor with constant or adjustable varying speed gave, by far, the best results. It is the only approved motor.

Television requires a motor which will not spark; sparking distorts the received picture. *The Baldor Variable Speed Motor has no brushes, commutator or automatic switch, or any device that can spark.*

Television requires a motor with little friction, so as to be able to follow the moving picture accurately.

The Baldor Motor is ball bearing, which means minimum friction, and is easy to keep accurate.

Television requires a very quiet receiver, so as not to transmit noises to the receiving set.

The Baldor Motor is quiet and humless.

Get the facts on this improved motor. Send for Bulletin No. 11.

INTERSTATE ELECTRIC CO.
4355 Duncan Avenue, St. Louis, Mo.

Distributors for the Baldor Variable Speed Motor



Television requires at the receiving end a motor which can be varied to suit. *The Baldor Motor is designed and built expressly for variable speed work. It is possible to vary the speed from 50 to 1100 r. p. m. in the 6 pole motor and 100 to 1700 r. p. m. in the 4 pole motor in gradual steps.*

Television in Colors

(Continued from page 320)

placed in front of the transmitter, and appeared on the receiving screen in a most vivid blue. This was replaced by red carnations, and the red blossoms appeared very clearly.

A human face was then transmitted, and when the tongue was put out, the pink color showed clearly, the face appearing in a different shade of pink. A policeman's helmet was then placed before the transmitter, and the blue shone up most strikingly. By far the most impressive part of the demonstration was a basket of ripe strawberries, the red fruit showing in an amazingly vivid fashion against the white basket. I also clearly saw the living moving images of a man tying a red and blue handkerchief alternately around his head.

At present there is great activity in preparing for the commencement of a broadcast television service in Great Britain. Television will be publicly demonstrated by Mr. Baird at the Radio Exhibition, to be held in London between September 22nd and 29th, and it is hoped to have the first receiving sets available at that time.

A popular type of "Televisor" will be marketed, this being a self-contained combined radio and television receiver, with a screen about nine inches square on the right and a dynamic type loud speaker mounted behind a grill on the left. It can be used as a normal radio set, and when television is being broadcast, it will merely be necessary to tune to the special station and then turn a switch to wake the television screen to life. There will probably be but two controls, and the current needed for operation of the television apparatus will be taken from a twelve-volt storage battery.

At the commencement the programs will be transmitted for one or two hours each evening and will consist of sole items such as entertainers, lecturers, cartoonists, comedians, etc.

One of the first stations to be put into operation will be 2TV, London, Baird's station, which uses a wavelength of 200 meters and a power of 4 kilowatts. Other stations will be opened in the leading provincial centres later.

Although the first programs will naturally be of a rather restricted nature, the experience in the operation of public television services in Britain and the U. S. A. must quickly lead to improvements.

FROM DOWN BELOW

Radex, our radio authority, says that he winds his own cigarettes.—*Popular Radio Weekly* (Australia.)

OUR BRITISH COUSINS HAVE 'EM, TOO

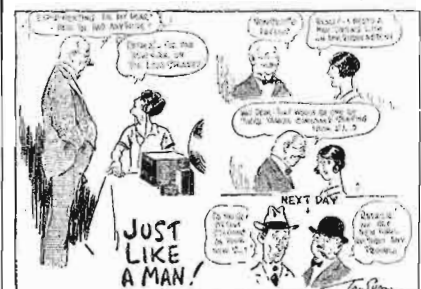

—Wireless Constructor (London).

Send for WESTERN RADIO New 1929 Catalog

DEALERS AND SET BUILDERS

THE NEW 1929 Catalog is crammed full of the FINEST, NEWEST, nationally-known A.C. sets, consoles, cabinets, dynamic speakers, kits, eliminators, and accessories at LOWEST PRICES. Largest stock of Radio Parts. Prompt delivery. Write for our FREE catalog.

WESTERN RADIO MFG. CO.

128 WEST LAKE ST. Dept. RN-10 CHICAGO, ILL.

The Big Friendly Radio House



SET BUILDERS

Get this Book



Barawik, the first and oldest radio specialty house, offers you unusual service this year. Bigger stocks, quicker shipments, lower prices. Deal with an old established, reliable house. Get honest goods, honest service, honest prices. Barawik service makes you more money. Send now for big new Catalog showing lowest wholesale prices.

BARAWIK CO. 1101 Canal Sta., CHICAGO, U. S. A.

Mail This Coupon Now for Free Radio Guide

Name _____

Address _____

WHOLESALE PRICES

Here you will find a new up-to-date stock of kits, parts, accessories and sets—everything you want in radio. Write for Catalog "B," quoting special dealer's wholesale prices.

Allied Radio CORPORATION

711 W. LAKE STREET, CHICAGO

Please say you saw it in RADIO NEWS

The Listener Speaks

(Continued from page 368)

a choice of heterodynes, the writer would rather hear a peanut-whistle than a fog-horn grunt—wouldn't you?

Another beautiful mess in KOIN and KOIL—neither of whom can be heard clearly enough for identification when transmitting simultaneously. Still, we can separate WMAQ and WQJ from KFOA enough to get the announcements and music from either with only a faint whistle; simply because it appears that the Chicago stations are up a few kilocycles to let us in. On the other hand, KQW and WLEAF, as well as KFRC and WJZ are absolutely "the bunk"—the two Pacific Coast stations invariably have a bad grunt mixed up with their transmissions. If these fellows were about five kc. apart, we can see no real reason why the reception would not be clear for all except those actually situated under their aerials, who would be unaffected by the change; inasmuch as they were unable to tune that close in the first place, and the local would be so powerful that any overlap would be drowned out. It is a cinch that the thousands of listeners between the stations in question would have more of a chance of getting either one or the other of two stations on the same channel; and they should be able to get both of them, and clearly enough to identify and enjoy the program.

The re-allocation would give at least half again as many available channels, and perhaps twice as many; thus solving the problem to the last decimal. Very few, if any, stations would be required to cease operations, while those who wanted could make arrangements for splitting time so that no two stations would be using the same channel at the same time.

Of course, it all rests upon the possibility of close adherence to assigned frequencies, as a deviation of a kilocycle would raise Cain in some instances; but if Mr. Doolittle can regulate to 100 cycles, that is surely close enough.

Now, the theory that a channel must be wide enough to pass 8,000 cycles at least sounds O.K. on paper; but can any one explain to us why we are able to play half a dozen three-station groups with ten-ke. bands—and we know they are pretty close to being ten ke.; say within a half-ke. of the assigned frequencies? Isn't it possible that the factor of interference does not hold true for stations widely separated geographically?

Therefore, we would like to see something done in bringing pressure to bear on the Federal Radio Commission, toward the end of adopting this plan or something similar, assuming there are no serious flaws in the plan or that something can come of it in which there are no flaws. We are sure of one thing—anything would be better than the present condition, with heterodyning carriers on nine out of ten channels.

One authority recently stated that even though two 500-watters were separated by the entire width of the continent, and even though their normal voice range was only a few hundred miles, if they be transmitting on or near the same frequency channel, their carrier waves would heterodyne and cause such interference that neither of them could be understood. It is believed that

VOLTAGE SURGES

Deadly as a
Serpent's
Fangs!

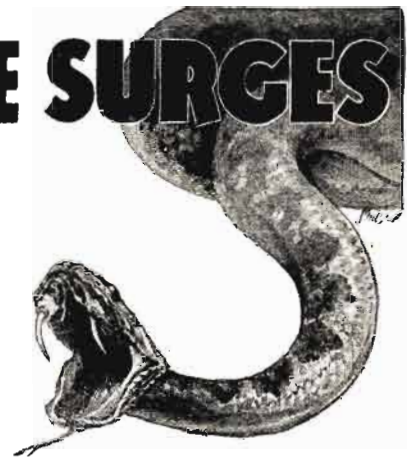

Play Safe With
PARVOLTS!

VOLTAGE Surges in electric-powered radio strike at filter condensers with the lightning speed and deadly power of a venomous snake.

Why take chances with ordinary condensers when ACME PARVOLTS give you positive protection?

Imperfect condensers, improperly-rated condensers, non-uniform condensers—all break down sooner or later under the destructive action of voltage overloads. Blown condensers usually mean blown tubes, burned out transformers and chokes, and even the destruction of speaker units.

These condensers are made only from highest grade insulation papers and special foils. Every detail of manufacture is under the constant supervision of experts who have devoted many years to the manufacture of condensers for heavy and continuous industrial duty.

Every PARVOLT is tested to R.M.A. and N.E.M.A. standards and can be relied upon for accuracy and **CONTINUOUS DUTY**. Sold by leading jobbers and dealers.

Made by THE ACME WIRE CO., New Haven, Conn., manufacturers of magnet and enameled wire, varnished insulations, coil windings, insulated tubing and radio cables.



ACME PARVOLT FILTER CONDENSERS—Supplied in all standard mfd. capacities for 200, 400, 600, 1000, and 1500 Volt D. C. requirements. Uniform height and width for easy stacking. Supplied singly or in complete housed blocks for the important power supply units such as Thordarson, Samson and others.
ACME PARVOLT BY-PASS CONDENSERS are supplied in all standard mfd. capacities and for all required working voltages.

ACME PARVOLT CONDENSERS

Made by the Manufacturers of

ACME CELATSITE WIRE PRODUCTS

- | | | | |
|---|--|---|--|
| <p>ENAMELED AERIAL WIRE
Enameled copper wire in both stranded and solid types. Also Acme Lead-ins, Battery Cables, Inductor and Loop Aerial Wires.</p> | <p>CELATSITE WIRE, FLEXIBLE and SOLID
For all types of radio wiring. High insulation value. Non-inflammable. 10 colors.</p> | <p>ACME COILS, MAGNET WIRE, & VARNISHED INSULATION</p> | <p>ACME SPAGHETTI
A superior cambric tubing for all practical radio and other electrical requirements. Supplied in 10 colors.</p> |
|---|--|---|--|

THESE

2

MAGAZINES

for

THE PRICE

OF

1



A year's subscription to these two popular magazines for the price of Radio News—alone. If you were to buy Radio News and Radio Listeners' Guide and Call Book individually for one year they would cost you \$5.00. By our special combination yearly subscription rate you can get both of these foremost radio periodicals at the tremendous bargain price of \$3.00. In order to keep up with the latest developments of Radio, to know the newest sets and how to build them, to find every radio broadcasting station you must read these leading periodicals of radio.

The RADIO LISTENERS' GUIDE AND CALL BOOK is the foremost quarterly magazine in the field. A special feature of this remarkable magazine is the up-to-the-minute log of every station in this country,

Special Combination Yearly Subscription Rate

\$3.00

For the Radio Listeners' Guide and Call Book and Radio News

EXPERIMENTER PUBLISHING COMPANY

230 5th AVE., NEW YORK CITY, N. Y.

Canada and in Europe. This list of call letters is carefully checked and corrected in each quarterly edition.

RADIO NEWS is read each month by more radio enthusiasts than any other publication in the field. It contains the latest developments and the most modern circuits of the radio world. Honest, unbiased opinions on every subject of interest—this is what RADIO NEWS gives you.

Write today—insure your receiving each issue of RADIO LISTENERS' GUIDE and CALL BOOK and RADIO NEWS. Take advantage of this special subscription offer—Two magazines for the price of one.

EXPERIMENTER PUBLISHING COMPANY
230 5th AVE., NEW YORK, N. Y.

Gentlemen—Enclosed find \$3.00 for which please send me the RADIO LISTENERS' GUIDE and CALL BOOK, and RADIO NEWS for one year beginning with the next issue. It is understood there will be no further payments of any kind.

Name
Address
City
State

the carrier wave interference is effective at about four times the normal voice range.

Something ought to be done and mighty quick; or there won't be any more DX! This, for thousands of radio fans, means no more radio for them! Let's see what can be done—we are open for suggestions. Why not move one-half the country's stations up or down 5 kc. as an experiment?

V. V. Rog,
South Gate, Calif.

(A problem in radio is caused by the harmonics of broadcast stations, many of which can be heard at several frequencies which are multiples of their carriers. The Radio Commission was led on this account to discard proposals to put several stations halfway between the even 10-kc. bands originally adopted. One of the troubles attending the broadcast reapportionment is the strength of other considerations beside those of sound radio engineering and practical business methods.—Editor.)

Likes the Ukulele

Editor, RADIO NEWS:

Having repaired sets for some time, I have come into contact with many radio fans, and they all wonder why the sweetest music is slighted. In short, they would all appreciate more, or at least some, Hawaiian music.

Many of my friends have written to studios, and their efforts were not even recognized. The hope of getting more Hawaiian music through the medium of Radio News gives me the incentive to write this, as I believe the first stations to wake up to its drawing power will become the most popular of all.

Wm. H. Pertz,
1514 East 94th St., Brooklyn, New York.

The Modulation Problem

Editor, RADIO NEWS:

In his article, "Vacuum Cameras to Speed Up Television," in the July issue of Radio News, Mr. Clarkson asks why it is necessary to employ a band of frequencies for television transmission, rather than a single frequency.

Surely, it is a well-known fact that electrical communication of any kind, whether it be by telegraph, voice or television, cannot be maintained by means of a single frequency. It is necessary in every case to employ a band of frequencies. Mr. R. V. L. Hartley, the noted research engineer, has shown in a fundamental study of the frequency relations in electrical communication, that the width of the frequency band or spectrum used is a direct measure of the speed with which intelligence of any kind may be transmitted. For 20-cycle telegraph transmission, the frequency-band width necessary for good signal quality is from 60 to 80 cycles. For voice transmission, a frequency band 8,000 to 10,000 cycles wide should be used. A well-known laboratory for communication research demonstrated recently that a frequency-band width of at least 20,000 cycles is necessary to obtain reasonably-good resolving power in television apparatus. This wide frequency band is, of course, rendered necessary by the enormous speed at which "intelligence units" must be transmitted in television.

Amplitude modulation of a carrier wave without introducing additional frequencies

REL REL REL REL REL REL REL REL REL

SCAN THE ETHER WITH The New "222" SHIELD GRID

Combining the proven, hyper-sensitive STROBODYNE system with the tremendous amplification obtained through the use of the new shield grid tubes, in a special circuit making full use of their extra high amplification factor.

The "222" STROBODYNE Latest Design by R. E. LACAULT, E.E.

Leaves far behind all other types of sets. Its performance has amazed experienced engineers and it has come through hard tests with flying colors.

SPECIFICATIONS

- 1—QUALITY OF REPRODUCTION
Through the use of high grade audio transformers combined with a push-pull amplifier and the best method of detection, the most remarkable fidelity is obtained. The results will amaze the most critical musicians.
- 2—VOLUME
The tremendous amplification of the shield grid tubes produce unusual volume which may, however, be regulated to any desired value through a special control.
- 3—SELECTIVITY
The very high impedance of the shield grid tube, combined with the special circuit used, makes the tuning very sharp without affecting the quality.
- 4—SENSITIVENESS
The sensitiveness of this receiver is so much greater than that of any existing set that it is beyond comparison. There is NO LIMIT to the range. The noise level is the only factor affecting it.
- 5—SHIELDING
Entire R.F. system completely shielded.
- 6—EASE OF CONTROL
Only two dials, a volume control and sensitiveness control are used—making the set easy to operate.
- 7—STROBODYNE SYSTEM
The STROBODYNE method of reception—a time-tested and proven circuit—is incorporated in the set, causing very weak signals to produce a tremendous response.
- 8—MATERIAL
Only the very best of tested parts are used in the entire set, insuring permanent high efficiency.
- 9—DESIGN
The new "222" STROBODYNE is designed by R. E. Lacault, E.E., well known creator of several famous circuits, whose reputation is a guarantee of the high grade radio engineering incorporated in this set.

Read how to build it in the September issue of Radio News and Blue Print No. 63

We are equipped to give you

PROMPT MAIL ORDER SERVICE

All genuine parts carried in stock

ORDER DIRECT from

R. E. LACAULT, INC.

116 West 65th Street, Dept. 405, New York City

Cable Address
LACRAD NEW YORK

Long Distance Phone
SUSQUEHANNA 2095

Please say you saw it in RADIO NEWS

Now Receive Broadcast on Short Waves

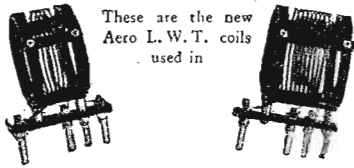
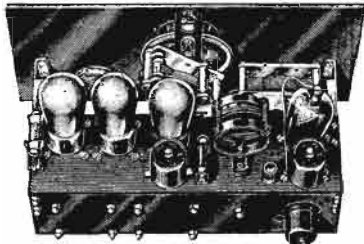

These are the new Aero L.W.T. coils used in

The Aero International

Broadcast reception on short waves is remarkably clear and free from static. Programs are brought in from greater distances with the utmost simplicity of control.

You can easily assemble the Aero International. This remarkable set is built around the new Aero L.W.T. Coils—the acknowledged leaders in the short-wave field. The foundation unit for this receiver comes with holes already drilled, assuring ease of construction and proper placement of all parts. As an aid to home builders, Aero Kits include both large schematics and actual size pictorial wiring diagram.

Ask your dealer for a complete Kit of all parts for the Aero International. If he can't supply you, write us, giving his name.

Uses Aero Coil L.W.T. 10 Kit

If you wish to purchase only the Aero Coils for this short-wave receiver, order the L.W.T. 10 Kit. The price is \$10.50. These coils are designed to be used with our foundation unit. If you prefer to furnish your own foundation unit, order the L.W.T. 11 Kit, price \$11.50. This Kit includes mounting base.

The New Aero L.W.T. 12 Coils

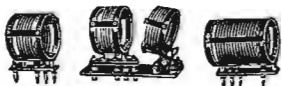

Here are the newest Aero Coils—the L.W.T. 12 Kit. These coils are small in diameter, providing a much smaller external field, and improved efficiency. Order this Kit if you want the very maximum results from your short-wave receiver. Consists of three Aero Interchangeable Coils and base mounting with Primary Coil. Price, \$12.50.

Convert Your Present Receiver

Build the Aero Short-Wave Converter and receive short-wave programs on your present set. No extra tubes needed. Just plug into detector socket of your set. Ask your dealer for complete Kit of parts or write us. We have complete Kits for shielded grid, A. C. or D. C.

AERO PRODUCTS
INCORPORATED

Dept. 105 4611 Ravenswood Ave. Chicago, Ill

in the process, as suggested by Mr. Clarkson, is manifestly an impossibility; for a change in amplitude is invariably accompanied by a change in frequency (i.e., a band of frequencies is immediately produced). This fundamental concept is almost as old as the art of electrical communication itself.

A clear idea of the nature of complex waves can be obtained, by anyone having an elementary grasp of the infinitesimal calculus, through reference to Byerly's "Fourier's Analysis and Spherical Harmonics," a book which has been in print, I believe, for twenty or thirty years.

Yours very truly,

T. A. JONES,
463 West Street, New York City

(In addition to Mr. Jones' letter, the address of which alone would indicate that he has some familiarity with his subject, another making similar representations has been received from Arnold Lesti, of Los Angeles, Calif.)

Good Reception "Down Under"

Editor, RADIO NEWS:

I am situated northwest of and about 400 air miles from Adelaide, about 800 air miles from Melbourne, 1,000 from Sydney and about 1,100 from Brisbane; and yet I can log all the Class "A" stations in these cities on an 8-tube set at very great speaker volume at any time of the day, and at any time of the year; and I have them at good speaker strength on a five-tube neodyne.

Curiously enough, the amateurs, and particularly those who work on wavelengths under 250 meters (*Experimental work on the broadcast band is more freely allowed in Australia, where there are comparatively few broadcast stations.*—Editor.) come in with very much greater strength than the "B" stations; although they use only from 15 to 50 watts, whereas most of the "B" stations use from 100 to 500 watts.

On Sunday last, February 19, I logged WOWO at good speaker strength at 6:30 p. m. (3:00 a. m. Central Standard Time—evidently an experimental transmission) or

A REMARKABLE

New SUPER TRANSFORMER

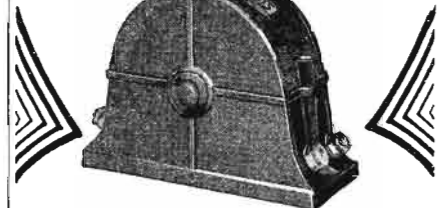

After long and particularly exacting tests the new Victoreen Super Transformer is now announced as a radically new and better product—one that will be as outstanding in its superiority during the 1929 season as the previous type has been in years past.

Write for FREE Blueprint

of the new and perfected Victoreen A.C. Circuit, using this marvelous new Transformer. The set is easy to build—of unsurpassed tone quality and reliability.

The George W. Walker Company
Merchandisers of Victoreen Radio Products
2825 Chester Ave., Cleveland, O.



Victoreen

This Book Brings Dealers BIGGER PROFITS

Matchless bargains in radios and accessories. Full line of Sleeper, Browning, Drake, Carter, Utah, Towers, Speakers, Temple, Majestic, Kodak, G.E. Tungar, Burgess, Jewell, Deiken, Cunningham tubes, nationally advertised parts, storage batteries, chargers, etc. Big opportunity for live ones who can sell radio. Double sales quick. Use your letterhead. Exclusive territories open. Act—NOW!
NEW ENGLAND MILLS COMPANY
Distributors of Nationally Advertised Radio Lines
Dept. R260 851-55 Washington Blvd. Chicago, Ill.

SET Builders **FREE**

Elections have brought back Custom Set building. Business is booming. Thousands of old-timers are cleaning up. Let Barawik show you the way to bigger profits, more sales. Send today for Barawik's Big Bargain Book—the radio man's bible.

BARAWIK CO. 2108B Canal St. CHICAGO, U. S. A.

A REAL SPECIAL OFFER!

LIST PRICE
\$39.50 EA.



EXTRA SPECIAL **\$13.75** ea.

Brand new, in original factory case, complete with extra fuse.

The New Gould Kathanode Unipower GOULD PRODUCT

WITH BUILT-IN RELAY

Automatic Radio "A" Power From Light Socket

Model AC-6-K (6-volt) Kathanode Unipower is the highest quality "A" Power Unit built. Furnishes rich, smooth, unfading "A" current without any trace of hum for the largest power tube sets. Installed in less than three minutes, makes any set as simple and convenient to operate, as an expensive AC outfit at only a fraction of the cost. No rewiring necessary in your set.

Its Kathanode construction insures longer life and freedom from service expense and when sold it will take care of itself. It is very economical and will outlast several storage batteries. Its Kathanode construction is an exclusive patented feature now being used by the U. S. Government in their Submarine Batteries which are furnished by Gould.

Equipped with a new noiseless Balkite Charging Unit which has four graduated charging rates and in addition one booster rate (1 1/2 amperes) for an emergency charge. Operates on 110-120 V., 50-60 A.C. cycle current.

AMERICAN SALES CO., 19-21 Warren St., New York City

about three-quarters of an hour before sunset, while the light was still very strong; and at the same time last night (the 21st) KFKB came in so loud that it could be heard distinctly 60 yards from the speaker, with a good wind blowing at the time.

Among other things, it would seem that locality plays a very important part in daylight reception; as in Adelaide, for instance, which is 400 miles nearer to Melbourne than we are, it is said to be quite impossible to get 3LO, or any of the other stations in Victoria or New South Wales in the daytime.

With best wishes for the future of Radio News, which is quite on its own as a radio publication, and which is widely read in Australia.

K. L. WILLIAMS,
Arcoona Station, via Pimba,
South Australia.

P.S.—Can you publish a list of the broadcast stations in Manila, as I have heard of besides KZRM, but have not been able to get the call signs on account of static? I think, however, they are KZRO, KZKZ, KZIB and KPM.

(While this reception is remarkable, it will be remembered that, though the receiver was in daylight at the height of an Australian summer, the transmission was in the dead of night in an American winter, and about nine-tenths of the path of the radio wave was in darkness.)

The latest official list of stations from Washington shows only three broadcast stations at Manila: KZIB, 260 meters, 20 watts; KZKZ, 270 meters, 100 watts, and KZRQ (succeeding KZRM) 413 meters, 1,000 watts. KPM is a commercial station. An American short-wave listener reports what seems to be a short-wave broadcast station giving its location as Manila. Has it been heard by others?—EDITOR.)

TIME TO RETUNE

"How do you like the program sponsored by the Goodstone Rubber Co."
"Aw, they tire me to death!"—W. G. M.

RADIO TERMS ILLUSTRATED

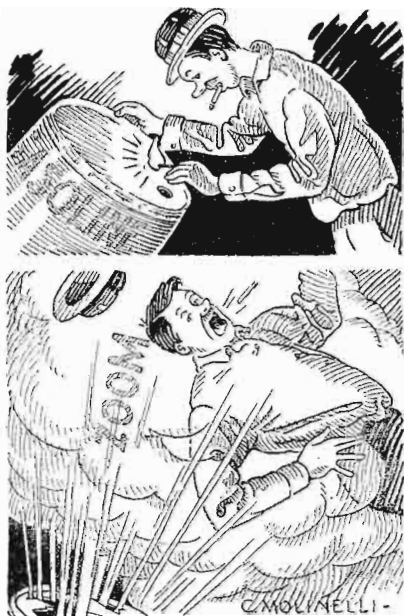

"Input"—"Output"

The New Knapp "A" Power Kit

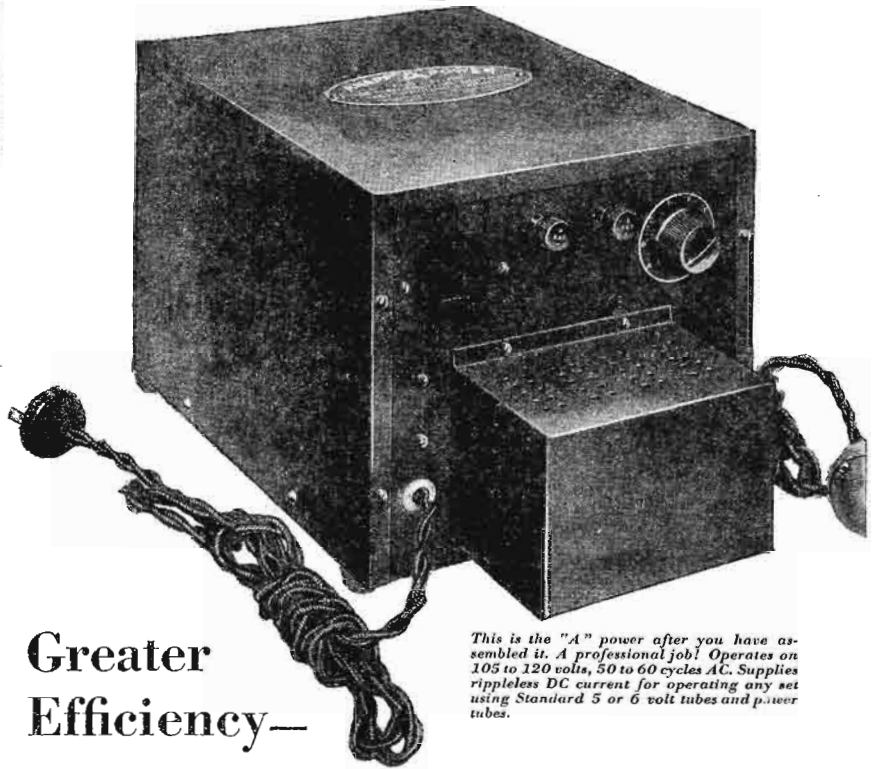

This is the "A" power after you have assembled it. A professional job! Operates on 105 to 120 volts, 50 to 60 cycles AC. Supplies rippleless DC current for operating any set using Standard 5 or 6 volt tubes and p-wave tubes.

Greater Efficiency—

Improved Design and Appearance—Lower Price—Money-making Plan for Set-Builders

You radio fans who made my "A" power the largest selling "A" power last spring have made it possible for me to offer the finest "A" Power ever developed—in Kit form—even more complete than before. Study the illustrations—read the improvements—and you will wonder how I was able to reduce the price. You are the answer. I sold 5 times as many "A" Powers as I expected to—and this season I am counting on you to help me again by buying even more.

The 8 Improvements

1. Larger Filter System — 3 Elkon Condensers instead of 2. Ideal for Super Hets and Short Wave Sets.
2. Improved Choke Coils
3. Pendant Switch Controlling "A", "B" Eliminator & Set
4. Dial for regulating voltage
5. Celeron Front Panel
6. Baked finish
7. Heavier gauge metal cover
8. Die Cast Base Plate instead of wood

THE SET-BUILDER TAKEN CARE OF

You set-builders played with me (as the saying goes) and I am going to continue to play with you. My engineers have designed an "A" Power which is well-nigh perfect—my production men, based on tremendously large quantities have cut their cost, so that I can keep faith with you by reducing the cost. And regardless of what the established trademay think about it—I am going to continue to give you the maximum discounts. The coupon will bring you the full details of both the new "A" Power and the special discounts to set-builders. David W. Knapp, Pres.



COMPLETE KIT—EASILY ASSEMBLED

Like my Kit last year, the New Knapp Kit is a toolled job—the parts seem to fall into place. Every hole is drilled—all that it is necessary for you to do is to put the screws and nuts in place and connect a few wires. Everything is supplied. Nothing for you to buy extra. The fool-proof instruction sheet makes it easy for anyone to assemble.

KNAPP ELECTRIC, Inc., Port Chester, N. Y.
—Div. P. R. Mallory & Co., Inc.—

Mr. David W. Knapp, President,
KNAPP ELECTRIC, Inc.,
336 Fox Island Road, Port Chester, N. Y.

Kindly send me complete information on the Knapp "A" Power and your special discounts for Set-Builders.

Name _____
Address _____

Transmission of Photo's by Radio

TRANSMISSION OF PHOTOGRAPHS BY RADIO—Various methods have been devised and are now in use for the transmission of photographs by radio. Among these may be mentioned the systems of *Belin* (q.v.), *Baird*, and *Jenkins*. The principles underlying the *Jenkins* system are explained under the heading of *Television*. Using the system developed by Capt. R. H. Ranger, photographs were transmitted by radio from Honolulu to New York, a distance of 5,136 miles. Recently commercial picture transmission service has been inaugurated between New York and London using the Ranger apparatus. Two distinct methods have been applied for analyzing the picture in the process of trans-

the electron flow constitutes a discharged circuit, so that the grid becomes less negative. The first amplifying tube is a direct current potential amplifier, and is resistance coupled. The grid and plate connections of the amplifier are connected across a condenser which becomes discharged with the fall in the grid to plate resistance of the valve brought about by the grid potential fluctuations. A charging circuit is connected to the condenser and is controlled by a valve, the grid circuit of which operates by variations of the potential across the condenser. The charging current is fed through the plate circuit of this valve, in which a relay is connected, which working through other mechanical relays in

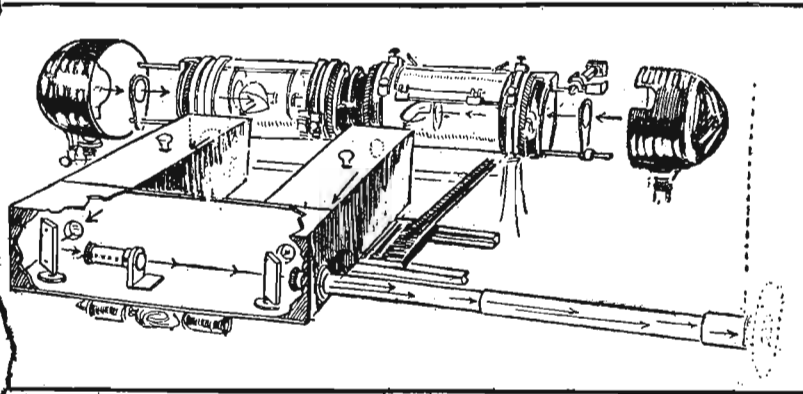

A pencil of light traverses the picture which is attached to the glass drums and is analyzed by a slow rotating action as well as a backwards and forwards movement of the carrier.

mission. One arrangement consists of producing an image as a non-conducting deposit upon a metal foil which is traversed by a stylus, while the other method makes use of an opaque image deposited upon a transparent film which is traversed by a beam of light, the light interruptions being recorded by a light sensitive cell. The Ranger system makes use of this latter method. The image is photographed and recorded upon a cellulose acetate film.

casades, controls the radio transmitter. Wave trains from the transmitting station after detection and amplification, are applied to the picture recorder. The recording mechanism, in order that it may be sensitive to exceedingly small currents, comprises a small moving coil, in a magnetic field created by three electromagnets. The coil of wire, in moving in the field, as the received fluctuations

S. Gernsback's Radio Encyclopedia

A facsimile of a portion of a page from S. Gernsback's Radio Encyclopedia is reproduced herewith. A glance at the thorough manner in which each item is treated cannot fail to instill a true appreciation of the value of the remarkable book. S. Gernsback's Radio Encyclopedia is the first ever published. It is not a dictionary. It covers every possible phase of radio. Every circuit, each piece of apparatus, all the leading characters of the industry, broadcasting, receiving, television, telephoto, everything connected even in the slightest way with the growth of radio or its kindred sciences, is most authentically explained. There are over 1930 separate definitions, 549 illustrations, a complete cross index, and many other special features. S. Gernsback's Radio Encyclopedia comes in two beautiful bindings, large 9 x 12 in. size.

Cut here **COUPON** Cut here

- Beautiful Limp Suede Edition (de luxe) \$5.00
- Keratol-Leather Stiff Binding.....\$2.00

Write your name and address in the margin below, mark which binding you prefer, and the book will be sent to you C. O. D. plus postage.

S. GERNSBACK

230 FIFTH AVE. NEW YORK, N. Y.

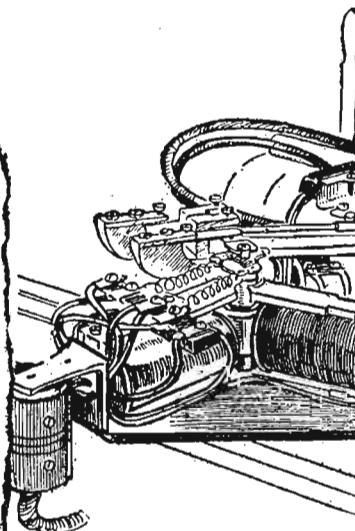

recording mechanism of the receiver. The stylus, which is a moving coil, is applied through its windings, traverses the surface of the paper. The stylus traverses the paper in perfect synchrony with the carrier of the transmitter, the paper being lifted

Adjusting and Operating the Screen-Grid Strobodync

By R. E. LACAULT

VERY thorough instructions were given in the September issue of *RADIO NEWS* for the construction of the new Screen-Grid Strobodync receiver (Free Blueprint Article No. 63). Some further suggestions, however, may be welcomed by the constructor as to the operation of this wonderfully sensitive receiver in order to take fullest advantage of its possibilities.

It will be found that the voltages shown in the diagrams (Fig. 1, page 236) are about correct, as stated previously; but in many cases the signal intensity may be increased by raising the voltage on the screen-grids of the tubes to some value between 45 and 67. It is also recommended that a separate battery be used to supply the voltage for the screen-grids of the tubes; because this avoids the chance of a feedback between this grid circuit and the "B" battery circuit; that is, the supply which is connected to the plates of the various tubes. If the "B" batteries used are new and do not have much internal resistance, it is satisfactory to use the same set of batteries; but, when the batteries are beginning to weaken and their internal resistance increases, it is preferable to have a separate battery for the screen-grid circuits. On an efficient "B" power unit, where all the taps are by-passed by the necessary condensers, it is satisfactory to connect the screen-grids to the 45-volt tap, or a slightly higher potential if required.

OPERATING THE SET

The tuning of the receiver is not difficult and, although the dials do not run exactly alike over the entire scale, they are sufficiently close in reading to find easy stations between 200 and 550 meters; that is, over the entire broadcast band. In normal operation the rheostat (R2) should not be turned on quite full; that is, its slider should be placed about a quarter of an inch away from the end. When receiving weak signals, the sensitiveness of the set is somewhat increased by reducing the filament current of the Strobodync tube (V2) and you will notice that on most weak stations the signal will increase in intensity when the tube almost stops operating; that is, when the rheostat is turned just a little too low. If the tubes stop operating, turn the rheostat on again and reduce it slowly until the most sensitive point is found, where the signals are the loudest. This amplification is obtained on most stations, but it seems that the percentage of the modulation of the carrier wave has something to do with the amplification obtainable by this method.

On most stations, however, some increase is obtained by burning the tube as low as possible without stopping it from operating. The volume-control resistor (R9) is used merely to reduce the volume when signals are too strong, as happens on local stations and even on some of the distant stations which are received like locals.

ADJUSTMENTS

After the receiver has been placed in operation, it is necessary to adjust carefully the small adjustable condenser C21 in order to obtain maximum efficiency from

the R.F. circuits. This condenser is employed to balance the circuits in shields S1 and S2, so that the simultaneous one-dial tuning is as efficient as if two dials were used. The first step in making this adjustment is to tune in a low-wave station and disconnect the ground wire from the set. With only the aerial connected, it probably will be found that stations operating on waves below 300 meters may be received at two points on the left tuning dial (C1 and C2), and this is indicative of the fact that the circuits are not properly balanced.

To correct the condition described above, the adjustment screw of the condenser C21 is turned in one direction, and then in the other, until a point is found where there is only one setting on the dial for receiving any given station. For example, it may be found that the two points at which a low-wave station may be received on the left dial are 5 and 9 degrees. Also, it will be found that turning the adjustment screw one turn to the right causes the dial settings to change to 5 and 11 degrees, and that turning the screw to the left causes the settings to be 5 and 7 degrees. Under these conditions, therefore, it will be necessary to turn the screw further to the left until the highest setting is reduced to 5; or until only one point on the dial remains at which the low-wave station may be tuned in.

Because of the simplicity of its controls, the set is tuned and operated very easily by anyone; and this makes it more practical than the former model, described in *RADIO NEWS* for August, 1927. The original Strobodone had more controls to manipulate and it was somewhat more critical than the new design; in which many things have been improved and corrected in order to make this circuit more efficient all around and better in every particular.

The Screen-Grid Strobodone is designed for operation only with an aerial; but any aerial will operate it, and this means anything from a few feet of wire to a regular 100-foot installation, such as are used for the majority of sets. If one cannot put up an outdoor aerial, the set will operate very satisfactorily with any sort of indoor energy collector; such as a piece of wire fastened around the picture molding, or even laid under the carpet in the room. The ground may be anything from a water pipe to a radiator, or any large surface of metal which is in electrical contact with the ground.

It should be pointed out also that there are on the coil L1 three terminals to which the aerial may be connected. These posts are marked 2, 3 and 4, and the aerial should be connected to the one which provides the best results.

Because of its design, this set is unsuited to the reception of short-wave broadcasting below 100 meters. We do not advise the builder to try to adapt it to the reception of short waves, because it tunes too sharp for this purpose and there would be required several changes in the circuit which are not considered advisable.

In conclusion, the writer wishes to repeat the fact that he considers the Screen-Grid Strobodone the most sensitive receiver he has ever handled and the most satisfactory all-around receiver for broadcast reception. If carefully built, in exact accordance with the instructions given in this article, the most blasé experimenter will find new thrills in operating this marvelous receiver.

HAMMARLUND'S New Contributions to Better Radio

Shield-Grid Coils

Exceptionally efficient low-resistance, space-wound, self-supporting inductance, 2 inches in diameter, for real results with shield-grid tubes.

A high-impedance primary with three taps for desired pick-up and selectivity.

Antenna coupler and R. F. Transformers for use with either .0005 mfd. or .00035 mfd. condensers.

Vertical mounting bracket. Convenient soldering terminals.

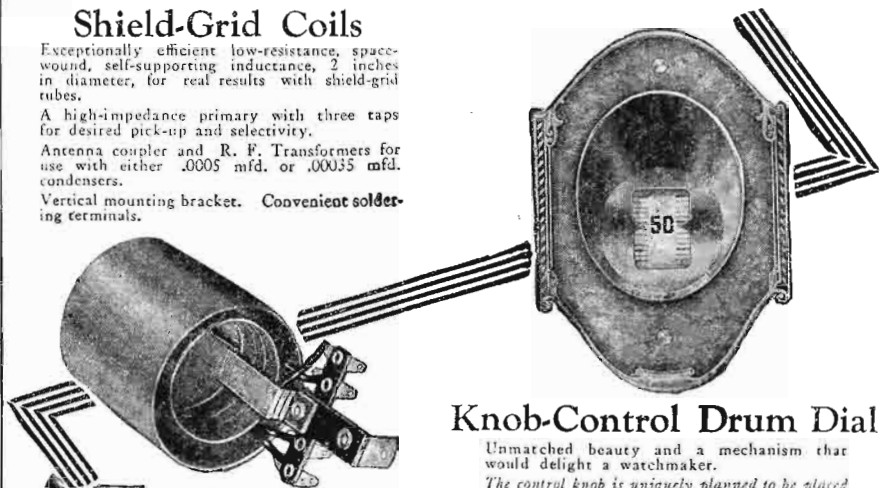

Knob-Control Drum Dial

Unmatched beauty and a mechanism that would delight a watchmaker.

The control knob is uniquely planned to be placed in any position on the panel desirable for attractive balance.

Numbers and degrees on a translucent drum illuminated from the back.

For the Short-Wave Fan

Plug-in Coils, covering the short-wave bands from 8 to 215 meters.

Extremely low resistance; widely-spaced plug-in terminals. Adjustable primary, held in any position by friction.

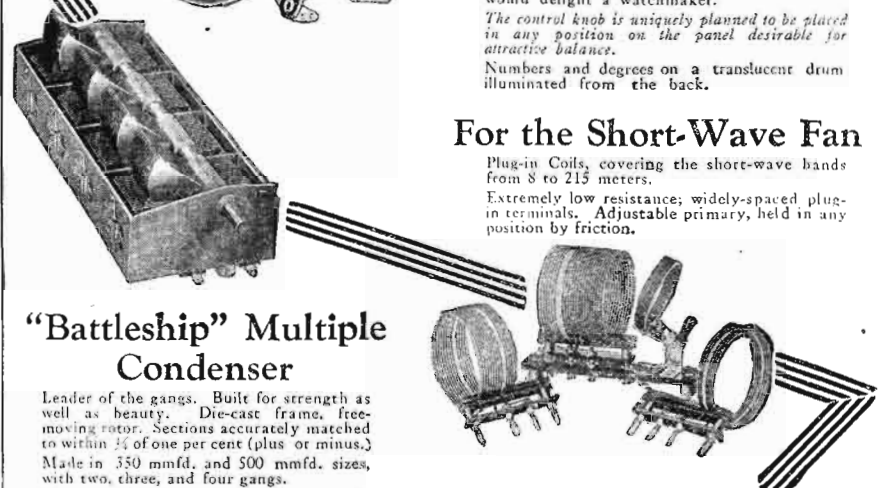

"Battleship" Multiple Condenser

Leader of the gangs. Built for strength as well as beauty. Die-cast frame, free-moving rotor. Sections accurately matched to within 1% of one per cent (plus or minus.)

Made in 350 mmfd. and 500 mmfd. sizes, with two, three, and four gangs.

Recesses in the frame permit direct attachment of new type Hammarlund Equalizing Condensers for utmost precision.

Write for literature on these and other new Hammarlund developments.

HAMMARLUND MFG. CO.
424-438 W. 33rd St. New York

For Better Radio
Hammarlund
PRECISION
PRODUCTS

FRESHMAN YOUR ULTIMATE RADIO

AT ALL
AUTHORIZED
DEALERS

FREE Wholesale Radio Catalog

Set Builders-Dealers! Save Money!

Send for the most complete book of nationally known Parts, Kits, Cabinets, Consoles, Speakers, Power Units, Sets, etc. All at lowest wholesale prices. Quick service on all your needs. Write now. It is FREE!

SETBUILDERS SUPPLY CO.
Dept. 13-4 Romberg Bldg. Madison and Market Sts. CHICAGO, ILL.

BUILD YOUR OWN DYNAMIC SPEAKER

Complete set of blueprints and instructions for building your own Dynamic cone speaker. Easy and inexpensive to build at home with few tools. Guaranteed to work; thousands now enjoying Dynamic reproduction. Mail \$1.00 today and you will receive complete set, postpaid.

FANSPEAKER RADIO COMPANY
74 Dey Street - - - New York, N. Y.

SET Builders

Elections have brought back Custom Set building. Business is booming. Thousands of old-timers are cleaning up. Let Barawik show you the way to bigger profits, more sales. Send today for Barawik's Big Bargain Book - the radio man's bible.



BARAWIK CO. 2108 Canal St. CHICAGO, U. S. A.

8 POPULAR MODERN MOVIE NOVELS \$1.00

GREATEST OFFER EVER MADE

Take Advantage of This Amazing Bargain

Eight full size books for one dollar. Never before has an offer of this kind been made. Only quantity production permits us to make this astounding offer now. Take advantage of it while you have the opportunity. Needless to say these modern up-to-date movie hits cannot last long at this tremendous bargain price. Each book contains at least two color "stills" of an actual scene from the photoplay. Don't hesitate. Mail this coupon now. Every story based on an actual moving picture triumph. The greatest book bargain of the age.

Titles of This Tremendous Bargain Offer

1. New York
2. The Campus Flirt
3. Almost a Lady
10. Sensation Seekers
11. The Rambling Rangers
12. Don't Tell the Wife
14. Tracked by the Police
15. Tell It to the Marines
19. Irresistible Lovers
20. The Cohens and Kellys In Paris
21. The Divine Woman
22. Jazz Mad
23. The Crimson City
24. You Can't Beat the Law
25. Tillie's Punctured Romance
26. Forbidden Hours

8 BOOKS FOR \$1.00
Your Choice

An Addition To Your Library

These books will be a worthwhile addition to your library. You will find many hours of truly enjoyable reading in each beautiful volume. Printed on fine paper with large clear type. Beautiful colored covers of flexible durable material. These books are undoubtedly one of the greatest values ever offered at this amazingly low price.

Write Now! Don't Wait! This bargain cannot last long at this price

CONSRAD COMPANY, INC.

230 FIFTH AVENUE

NEW YORK, N. Y.

CONSRAD COMPANY, INC., 230 Fifth Avenue, New York, N. Y.

Gentlemen: Enclosed find \$1.00. Kindly send me the books listed by number herewith:

Numbers.....

Name.....

Address.....

City..... State.....

A REAL SPECIAL OFFER!



UNI-RECTRON POWER AMPLIFIER

(Ideal for use with Dynamic Speakers)

Model AP-935

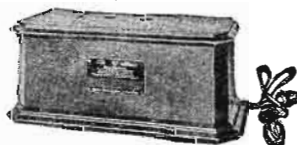

As the Uni-Rectron stands it is a super power amplifier, which can be used in connection with any radio set and loud speaker. Binding posts are provided for input to the Uni-Rectron and output to the speaker.

Requires no batteries for its operation. It obtains its power from the 110 volt, 60 cycle alternating current lighting circuit of your house.

The UX-210 super power amplifying tube and the UX-216B or 281 rectifying tube are used with this amplifier, which cannot overload. From the faintest whisper to the loudest crash of sound—R. C. A. Uni-Rectron amplifies each note at its true value. High and low notes are all treated alike. The volume and quantity delivered will be a revelation.

List Price \$88.50
(without tubes)

Special \$19.75 ea.
Every one new and packed in original factory carton

AMERICAN SALES CO., 19-21 WARREN ST., NEW YORK CITY
SEND FOR OUR LISTS OF RADIO BARGAINS

What's New in Radio

(Continued from page 312)

sparks produced by the brushes sliding over the surface are the cause of serious interference. At the transmitting end the motor is just as important an item, for the speed must be absolutely constant in order to allow motors at the receiving stations to operate at the same speed.

A feature of the motor which is shown in the picture is that it is of the induction type and, therefore, does not rely upon a commutator either for starting or running. This insures the fact that the motor will not cause interference. Secondly, the motor may be adjusted easily to any speed between 750 and 1,750 revolutions per minute, and it will hold its speed very constant after it has been adjusted. The motor has a high efficiency, the starting current is very low and it is cool running, quiet and clean. It is available in three types, one of which is intended especially for transmitting stations. A machined flange for the scanning disc and rubber cushioned bases for the motors are also available.

Manufacturer: Interstate Electric Co., St. Louis, Mo.

The "Combine" Receiver—

\$100 Prize Winner

(Continued from page 333)

at the rear of the triple condenser for still greater volume. This operation may require considerable experimenting before the circuits are properly adjusted, and it would be well to tune in a comparatively weak station for the purpose of making the adjustments.

The next problem for the set builder is to suppress oscillations in the long-wave set, and this is accomplished by adjusting the devices P1 and P2. In making these adjustments, best results are obtained when receiving a station operating near the lower end of the broadcast waveband. This station should be tuned in as loud as possible with the dial, and the rheostat should then be turned up until a whistle or squeal is heard in the loud speaker. While the set is whistling the units P1 and P2 should be adjusted with a screw-driver until the whistle disappears. If these units are adjusted properly on the low wavelengths the receiver will be stable in performance over the entire broadcast waveband; but it may be necessary to repeat this adjustment several times before best results are secured.

After the broadcast set has been adjusted properly it is very easy to operate. It is necessary only to turn the drum dial until the desired station is received, and then adjust the rheostat, R1, for the degree of volume needed.

In operating the short-wave section of the receiver the only important thing to remember is to use the correct coil for the wavelength which it is desired to receive. The wavelength range of the various coils is approximately as follows: red, 17 to 30 meters; orange, 30 to 52 meters; yellow, 48 to 103 meters, and green, 93 to 203 meters. With the proper coil in the socket, the oscillation-control knob R7 should be advanced, and the condenser dial C4 should be adjusted until the station is located. Then the knob R7 should be readjusted until a

clear signal is received. The knob R3 may be used to regulate volume, if desired.

Terms of Prize Awards

MR. SCHEPPELE, the winner of the \$100 prize for his ingenious "Combine" set, is a custom radio builder of Waterloo, Iowa; and his design of this receiver is the result of experiments which he has carried on over a period of several months.

It is the desire of RADIO NEWS to award such a prize every month; but it can be given only when a radio receiver or other apparatus embodying some novelty suitable for general construction is submitted by a home or community radio constructor. It cannot be awarded for an old design, however well built; nor for apparatus, however ingenious, which is too complicated for the average set constructor to put together with the aid of the RADIO NEWS blueprints. It cannot be given to a manufacturer or his engineer, as it is intended solely to encourage independent experiments and invention.

Applications to enter this contest should be addressed to "Editor Monthly Construction Feature, RADIO NEWS, 230 Fifth Avenue, New York, N. Y." and be accompanied by photographs showing that actual work has been done and a schematic wiring diagram, showing the circuit used, in order that its practicability and its novelty may be determined. All papers must be of good quality, with legible writing in ink or type-writing, and each sheet must bear the sender's name.

On receipt of these, the constructor will be advised whether or not he is to send in any apparatus. RADIO NEWS reserves the right to construct another receiver or other device using the prizewinning circuit, but substituting other components, for its illustrations and published blueprint diagrams. For the best entry from a home or custom radio builder each month which is suitable for and published as a Free Blueprint article, One Hundred Dollars will be paid, as we have stated.

In addition to this, if the idea is patentable, RADIO NEWS will pay the entire cost of taking out the patent in the name of the inventor and for the inventor's sole benefit. The publication of the article will protect the inventor for a period of two years. We believe that the combined experience of our army of readers should produce many ingenious and valuable designs for home and custom builders.

Station
WRNY
NEW YORK
326 METERS — 920 KILOCYCLES
and 2XAL, 30.91 METERS

*is owned and operated by the
publishers of this magazine
Our Editors will talk to you
several times every week—
See your Newspaper
for details
TUNE IN ON
WRNY*

the MERSHON CONDENSER
Modern Necessity for Electrical Radio...



The Mershon Condenser gives a very large capacity in a very small space. Is self-healing in case of puncture, and is unaffected by changes in temperature, or by moisture.

Expert radio amateurs used the Mershon Condenser for more than six years in their transmitting equipment. Today the Mershon Condenser is being widely used over the whole country in connection with electrical radio sets, whether new AC tubes are used, or battery sets are attached to house current thru the use of Eliminators.

*Send for
Your Free Copy
of
This Book....*

The AMRAD Corporation
Medford Hillside, Mass.

Please send a copy of your new book on the MERSHON CONDENSER, showing hook-ups and designs.

Name

Address

RADIO SCHOOL
SEND FOR CATALOG
MASSACHUSETTS RADIO and
TELEGRAPH SCHOOL
18 Boylston St. Boston, Mass.

FREE RADIO GUIDE

Radio has been changing so fast lately that it's hard to keep up with it. Barawik's Big Radio Guide will keep you posted on the newest wrinkles. Thousands of illustrations of sets, parts, new ideas. Big chance to save big money. Send for free copy now.

BARAWIK CO. 210C Canal St. CHICAGO, U. S. A.

Insure your copy reaching you each month. Subscribe to RADIO NEWS—\$2.50 a year. Experimenter Publishing Co., 230 Fifth Ave., N. Y. C.

E.C.A. "A" Eliminator, 60 cycle, 105-120 V.; output 2 1/2 amps; 6 V. No Battery—SILENT—\$16.00; "B" Eliminators, 150 V., 40 millamps, 4 taps, with 280 bulb, \$10.00; Model KW, 180 volts, 60 mills, 5 taps, 280 bulb, 2-5 volts, 1/2 amp. taps for power tube; "ASC" Eliminator, one unit, 2 1/2 amps, 6 V. A side, 180 volts, 5 taps, 60 mills "B"; 4.5-9, 40 volts "C"; Complete \$20.00; 2 ampere "Z" metal charger, electrolytic, \$6.50 Trickle, \$3.75; 2 amp. screw base DRI rectifier, \$2.25; Speaker output filter, protects speaker—\$1.50. Underground aeriols \$3.00 Dealers wanted. Catalog. **ELECTRO-CHEMICAL COMPANY OF AMERICA, Indianapolis, Ind.**

SECOND ISSUE JUST OUT



In This New Issue 20 20

Complete Instructions For Building a Television Receiver

There can be no question but that Television is here to stay. Like radio, its sudden popularity came practically overnight. It has taken a decided grip on public opinion and bids fair to sweep the entire country in a never-before-witnessed blaze of enthusiasm.

So, fans! Dig out the old soldering iron, the bus bar and the rest of your paraphernalia and get to work on the latest hobby: Build yourself a Television Receiver.

Of course, Television is far from perfected. It is still in a most elementary stage. There is little use in trying to gloss over the truth. But a start has been made and it remains for the "fans" to do their share, as in radio, in developing the new art.

In the latest issue of TELEVISION there are full instructions from which you, ambitious enthusiasts, can construct an efficient experimental set. With this set you will be able to receive some of the Television programs now being broadcast. Experimenting will continually improve reception. Get your copy of TELEVISION today! Start to work on your Televisor tonight! Be the first in your neighborhood to have a Television set. The old "fan days" are here again. Don't miss the fun!

Partial List of Contents

HOW TO BUILD A TELEVISION RECEIVER

- | | |
|---------------------------------------|---|
| New Jenkins Radio Movies | Practical Demonstrations Scheduled for Station WRNY |
| New Berlin Photo Transmitter | Campbell Swinton Television System |
| Vacuum Cameras to Speed Up Television | Quartz Crystals Synchronize Television Sets |
| Infra-Red "Eye" Sees at Night | Baird Optical Lever Increases Speed |
| Valensi Television | Recording Pictures with Air Jet |
| Connection of Photo-Electric Cell | How to Build a Radio Photo Recorder |

and many other articles of equal interest

THE **25c** COPY

At all newsstands, or write direct

EXPERIMENTER PUBLISHING CO., INC.
230 Fifth Avenue, New York, N. Y.

EXPERIMENTER PUBLISHING COMPANY, Inc.
230 Fifth Avenue, New York, N. Y.

Gentlemen: Please forward to me a copy of TELEVISION. Enclosed find 25 cents.

Name

Address..... City..... State.....

Please say you saw it in RADIO NEWS

Television—"Seeing" Music

(Continued from page 315)

This rheostat is connected simply in series with the motor. Try any rheostat you happen to have on hand, and see how much control it gives.

Of course, the radio receiver need not be mounted on the top of the framework, as shown. One of the new Stewart-Warner

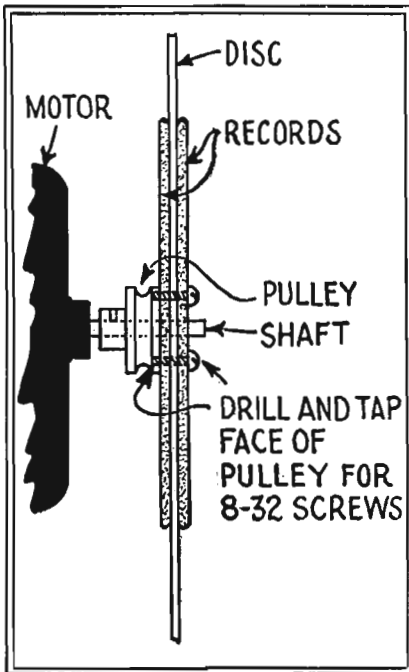

Fig. 2. The method of clamping the scanning disc to the fan shaft. It must be centered exactly.

A.C. receivers, which had been submitted to the Radio News Laboratories for test, happened to fit nicely in this position, so it was used.

The method of connecting the neon tube is shown in Fig. 3. A "B" battery of 180 volts is required for the neon tube itself; although fairly good results will be obtained if the high-voltage side of a "B" socket-power unit is used. The resistor marked R in this diagram is not the motor rheostat marked R in the picture on page 315, but a universal-range rheostat for adjusting the local current through the neon tube; it should have a resistance of from 200 to

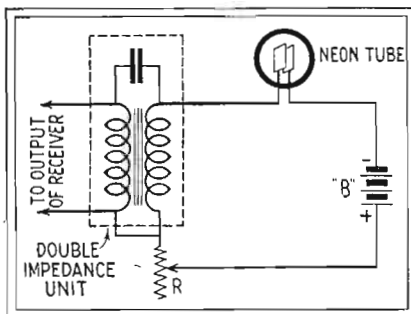

Fig. 3. Schematic diagram of the lamp circuit. This resistor R is not the one pictured in Figs. A, B and C (which is in the motor circuit) and it does not require continual adjustment.

500,000 ohms. The procedure is to adjust this rheostat until the neon tube just lights up; then the signal fluctuations will cause

New T.C.A. AMPLI-PACK

Makes Your Set an Ultra-Modern A. C. Power Receiver

A Complete A.C. Power Supply—"A" and "B" and "C"—Makes any D.C. Set into an Ultra-Modern A.C. Receiver. Uses two 210 type tubes in Push-pull; or one of the new 250 type tubes. Power Amplification gives perfect reproduction over the entire musical scale range.

Lets You Enjoy Real Musical Reception

Clear, bell-like tone. Powerful volume. AmpliPaCk gives you an advanced radio instrument at less cost than ever before offered. Consumes no more current than an ordinary 50-watt light. Cool, quiet, dependable.

Quickly Assembled

You can assemble an AmpliPaCk easily in one evening. A screw driver, a pair of pliers and a soldering iron are all the tools needed. We supply complete layout diagrams. Simple to install. Attached to set in 3 minutes.

171 Push-Pull and Straight 210 Power Packs

Complete power supply units for home constructed amplifiers. Compact, scientific design together with silent, absolutely dependable operation make these our most popular Power Packs for home construction.

At All Leading Dealers

Ask your dealer for AmpliPaCk. He can give you full details and our simple assembly diagrams. Don't be satisfied with out-of-date reception—build an AmpliPaCk tonight!

TRANSFORMER CORPORATION OF AMERICA

1428-32 Orleans St.
CHICAGO, ILL.

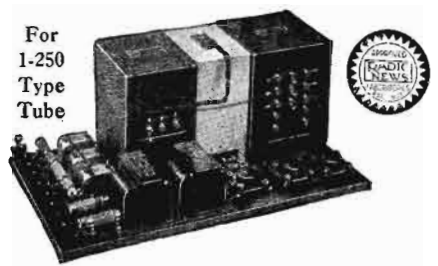

For 1-250 Type Tube

The T. C. A. High Quality Line

also includes

AUDIO TRANSFORMERS
AUDIO OUTPUT CHOKES
POWER PACKS and CHOKES

and other Transformers

Every coil in our Transformers is vacuum impregnated with a special compound. This prevents moisture disintegration and short circuiting. Clean cut laminations make them hum proof and banish noise interference.

Send Coupon for Free Booklet

Transformer Corporation of America,
1428-32 Orleans St.,
Chicago, Ill.

Please send me Booklet on your complete line of radio products. No obligation or cost.

Name
Address
City..... State.....



All the New Kits

Everything in radio—kits, parts, accessories, sets. Improved designs and styles. Big selection at worthwhile saving. Immediate service; personal attention. Send for complete, illustrated Catalog "B."

Allied Radio CORPORATION
711 W. LAKE STREET, CHICAGO

\$5.50 buys this famous cabinet!

The Ireyline
Sizes range from 7x18x10 to 7x30x12. Mahogany finish, \$5.50 to \$8.75. Solid Walnut, \$6.50 to \$10.25. F.O.B. Hickory. Twelve-hour service. Write for Catalog.
SOUTHERN TOY COMPANY, MANF'R. HICKORY, N.C.

FREE RADIO GUIDE

Radio has been changing so fast lately that it's hard to keep up with it. Barawik's Big Radio Guide will keep you posted on the newest wrinkles. Thousands of illustrations of sets, parts, new ideas. Big chance to save big money. Send for free copy now.

BARAWIK CO. 210CC Canal Sta., CHICAGO, U. S. A.



**Easy to build... unequalled performance
.. at a price you will be glad to pay**

- Marvelously Realistic Reproduction
- Remler Audio System Perfect Control of Volume from Maximum to a Whisper.
- Simple to Operate Expert Results for Every Member of the Family.
- All the Selectivity that Could be Desired
- Clean-Cut Separation of Stations on Adjacent Channels.
- Superheterodyne Sensitivity Shield-Grid Amplification.
- Stable Operation Completely Shielded Throughout.
- Easy to build Can be Assembled, Wired and Put into Operation in One Evening. No Special Knowledge or Experience Necessary.
- Most of the Wiring Completed and the Circuits Balanced at the Factory Only a Few Wires to be Installed by the Builder in Accordance with Color Code.
- Eliminator or Battery Operated.
- Combined Power Amplifier and Plate Supply CX 350 (UX 250) Power Tube Full Wave Rectification B Voltage Regulation Provided For.
- Steel Chassis Amplifier Construction Compact and Rigid.
- Power Transformer Primary Tapped for Different Line Voltages.



REMLER POWER AMPLIFIER

The story of the "29," what it is and what it does, is complete in Bulletin No. 17. Sign the coupon for your free copy.

Remler Division, Gray & Danielson Mfg. Co.
260 First Street, San Francisco, California.

Gentlemen: Please send me:

All the "dope" on the "29".

Bulletin service for professional set builders.

Name _____

Address _____

City _____ State _____

WRITE TODAY

Send for large, new illustrated Catalog "B," showing the latest of everything in radio at wholesale prices.

Allied Radio CORPORATION
711 W. LAKE STREET, CHICAGO

PATENTS As one of the oldest patent firms in America we give inventors at lowest consistent charge, a service noted for results, evidenced by many well known Patents of extraordinary value. Book, Patent-Sense, free. Lacey & Lacey, 631 F St., Washington, D. C. Estab. 1869

the light to vary and the patterns will appear.

To "see" music with this television receiver, tune in a broadcast station in the usual manner, and then connect the left side of the output impedance unit to where the loud speaker normally attaches to your set. Start up the motor and look through the disc into the neon tube, and you will observe the music "pictures" immediately. By varying the speed of the motor, you can make the patterns move back and forth, and up and down, and perform many other interesting antics. By connecting the loud speaker in series with the double impedance unit, both it and the neon tube can be made to operate together; and the different effects produced by different notes can readily be compared.

Although this entire machine is a crude affair, there is no reason why it cannot be made to reproduce actual television images; provided, of course, the listener is within range of one of the stations now transmitting television impulses. Station WGY is on the air every Tuesday, Friday and Thursday afternoon between 1:30 and 2:00 p. m., Eastern Standard Time, transmitting on its regular 380-meter wave. By the time this article appears, other stations will also probably be on the air with television. If you can pick up a television program, try it on this crude television; you may have good luck and actually see pictures

The Radio Beginner—The "Milk-Shaker Special"

(Continued from page 327)

The socket for V2 is located 1 inch from the right edge of the baseboard and about 2½ inches from the rear edge. The filament-ballast resistor R3 is located directly in front of the socket, and the vertical mounting for the grid leak R4 is fixed at the rear of the socket. Next, complete the assembly of parts on the baseboard by mounting the R.F. choke coil L5 near the front edge of the baseboard slightly to the left of the filament-ballast resistor.

Arranging the parts on the front panel is a very simple matter after the panel has been drilled. The layout in Fig. 3 shows the location of all holes required and also the size drill needed for drilling the holes. The hole on the left side of the panel is for the rheostat R2, and the hole in the same corresponding position on the right of the panel is for the variable high resistor R5. The battery switch SW is mounted near the bottom of the panel in the center, and the jack J is located in the hole in the lower right corner of the panel. The remaining holes are for mounting the two variable condensers, C1 and C2.

WIRING SUGGESTIONS

Before starting the wiring of the receiver, it is wise to fasten the front panel to the baseboard with three wood-screws. This is necessary because there are a number of wires which connect parts on the panel with those on the baseboard.

When wiring the set it is best to use the pictorial wiring diagram (Fig. 4) as a guide for making connections. In this diagram each piece of apparatus is shown in its correct position; but the scale of the parts in relation to that of the baseboard has been reduced somewhat, in order to allow ample space for showing the wiring.

Latest GREATEST RADIO CATALOG and GUIDE

THE BARAWIK CO. has, all these years, been famous for its variety of radio supplies, which it offers at money-saving prices. Newest dynamic speakers, "B" eliminators, socket power equipment, A-C harness, fine cabinets and furniture, amplifiers, latest amateur equipment, tubes, batteries; in fact, anything you can ask for is here, ready to ship, at a saving in price. Quality merchandise, selected goods by reliable makers — just what you want — at big discounts.

Your Savings are Tremendous

Ask any of the quarter million Barawik customers why they trade here, and they'll tell you that, **quality considered**, our prices can't be beat. That's something to think about! Quality comes first—new, fresh, good reliable merchandise, but the price always means a tremendous saving, nevertheless. Get our catalog and prove this to yourself. Don't spend a nickel until you see our offerings first.

You need this great radio bargain book as never before — **Mail the coupon now — TODAY.**

FREE LATEST RADIO GUIDE

BARAWIK CO. 210 Canal St., CHICAGO, U. S. A.
Mail This Coupon for FREE Bargain Book.

Name _____

Address _____

mail Coupon NOW

DRESNER

SHORT-WAVE CONVERTER

WAVE-LENGTH RANGE 15 to 550 Meters

COMPLETE \$22.50 (SPECIAL)

May be used with any type of broadcast receiver. Easily connected in just a few moments' time. No complicated wiring. Simply plugged into the detector socket in the set. Covers the entire range of wave lengths from 15 to 550 meters. Maximum satisfaction from top to bottom. Don't miss the excellent programs now being broadcast on the short waves. Get a Dresner Converter. Five interchangeable coils furnished with each unit. If your dealer can't supply you, call on us direct.

Write for booklet

DRESNER RADIO MANUFACTURING CORP.
640 Southern Boulevard New York, N. Y.

MOVIES teach YOU ELECTRICITY

AMAZING new film method prepares you at home, easily, quickly, for bigger pay jobs in all branches of electricity: Radio, Automotive, Aviation, Switchboard Work, etc. Actual motion pictures make everything simple and clear, and train you for a better job and more pay.

DeVry Motion Picture Projector and thousands of feet of film supplied at no extra cost. Easy to operate in home. No dry text books, but live, fascinating instruction. Practising engineers endorse training as sure, quick, practical.

We promise in writing to help get you a better job and more pay, or you need not pay a cent.

FREE Three Lessons and New Book, "The Film Way to Bigger Pay in Electricity." Send coupon for your copy now.

National School of Visual Education
537 S. Dearborn St., Dept. 100 Chicago

Please send free lessons and book, "The Film Way to Bigger Pay in Electricity."

Name _____

St. or R.F.D. _____

City _____

State _____

er 60,000
traits

FANS! third 1