

Neutrodyne 2 R.F.; 3 Reflex Portables; Flewelling

Radio Digest

EVERY WEEK

Illustrated

TEN CENTS

REG. U. S. PAT. OFF. & DOM. OF CANADA

Vol. V

Copyright, 1923
R. D. P. Co. Inc.

SATURDAY, JUNE 30, 1923

No. 12

CAN RADIO STOP AUTO?

AMERICAN AUTHORITIES FOR AND AGAINST GERMAN STUNT

Dean C. C. Winn, Detroit Institute of Technology, Believes Possible—Chicago Engineers Express Doubt—Say Nauen Couldn't Do It

By F. J. Huntley

DETROIT.—C. C. Winn, dean of the College of Engineering of the Detroit Institute of Technology, has a vision of future warfare by Radio with gigantic towers hundreds of miles apart shooting at one another from their antennae, powerful magnetic fluxes with a view of neutralizing one another's demagnetizing powers.

Prof. Winn expressed this idea while discussing recent information from Berlin that twenty automobiles recently had left that city, each using the magneto method of ignition, with the only instruction to follow the leading car, and with the anticipation that something unusual was going to happen.

When the party reached the Duchy of Mecklenburg every car stopped suddenly, as if something had happened to its engine.

(Turn to page 2)



Alyce Mills, winner of many beauty contests, heard over WJZ recently. Miss Mills played a leading role in "A Wife in Name Only" theater-Radiophans will recall
Digest Photo

CFCN FANS TO HEAR JACK-TOMMY FIGHT

BIG MATCH WILL BE FIRST EVER BROADCAST

Sensitive Microphones to Be Placed at Arena—Sound to Be Relayed to Calgary Plant

By Jeffrey J. Dingman

CALGARY, ALTA.—For the first time in the history of Pistiana and for the first time in the history of the Radiophone, the details of a battle between two nationally-famous men for the crown denoting the possession of the heavyweight boxing championship of the world, will be sent over the ether waves by a Radiophone broadcasting station.

When Jack Dempsey, world's heavyweight champion, and Tommy Gibbons, challenger, meet in the giant arena in the boom town of Shelby, Montana, on July 4, Independence Day, the details of that memorable contest will be sent broadcast all over the world through the medium of CFCN, the Radiophone broadcasting station of the W. W. Grant Radio, Ltd., at Calgary, it has been announced by W. W. Grant.

Will Relay to Station

Plans for CFCN broadcasting the fight are now being made. It is probable that three or four highly sensitive microphones of the type employed for vaudeville and cabaret work, will be placed at the arena, sound relaying to the station at Calgary.

(Continued on page 4)

The Wildflower Girls of Woodland, in the Adirondacks, New York, practice dancing outdoors. Peggy Stohl (right) teaches Betty Nevins (center) new steps while Muriel Harrison (left) tunes in © K. & H.



PARTS BEING SENT FANS FOR COUPONS

EARLY RETURNS INDICATE OFFER APPRECIATED

Reply Given to Queries—Many Readers Sending in More Than One Coupon Series

SPECIAL REWARD OFFER Coupon Number 5

This Special Reward Coupon appears each issue in Radio Digest until further notice. When sent in, accompanied by necessary remittance, according to the rules governing same, apparatus can be secured. See apparatus list and rules of offer below.

Save Me—I Am Valuable

Questions in the letters of the numerous Digest readers taking advantage of the Special Reward Offer coupons, indicate that some points are not yet clear. One query is, "How many consecutive series of coupons will be accepted?" The answer is simple. There is no limit.

With only four coupons published, many letters containing the four, sixty cents remittance, and a selection request for some article in Class B, have been received. These Radiophans, of course, have already been sent the apparatus they selected.

The simplicity of the method of getting the many standard and valuable parts and accessories for sets, in practically every case has appealed to the enthusiastic readers. All that is necessary is to clip the consecutive coupons appearing weekly on page two, and send them, accompanied by the necessary remittance for the selected item, to the Digest.

Rules to Remember

One point must be emphasized to those contemplating taking advantage of the special offer; that is, that the coupons turned in for any item must be numbered, consecutively, as for example, 1, 2, 3, and 4 or 3, 4, 5 and 6. The number of coupons necessary and the cash remittance, of course, depend on the item sought by the reader. There is no limit to the number of series turned in by any one reader.

Another point to remember is that cash, checks and money orders but no postage stamps will be accepted. To make selection more simple the items have been divided into eight classes, each class depending on the number of consecutive coupons and amount of cash remittance necessary. The eight classes of items follow:

Class A Articles

For two consecutively numbered coupons and thirty cents (\$0.30) any one of the following articles will be sent: 1 Carter Imp Jack and Plug; 1 Carter 15-Ohm Resistance Unit; 1 Schindler .00025 mfd. Build-up Mica Condenser; 1 Schindler .0005 mfd. Build-up Mica Condenser; 1 Schindler .001 mfd. Build-Up Mica Condenser; 1 Schindler .002 mfd. Build-Up Mica Condenser; 1 Schindler .0025 mfd. Build-Up Mica Condenser; 1 Martin-Copeland Sta Put Plug; Walnut Standard Tube Socket; Walnut UV-199 Socket; Ray-O-Vac Dry Battery, 1 1/2 volts; Dubilier Micadons Type 601 (.0001, .00025, .0005, .001, .002, .0025, .003 or .004 mfd.); Premier Grid Condenser (.00025 or .0005 mfd.); Premier Variable Resistance; 1 Carter 25-ohm Resistance Unit; Standard Socket Adapter for Delta Midget Tube.

Class B Articles

For four consecutively numbered coupons and sixty cents (\$0.60) any one of the following articles will be sent: 1 Carter .04 mfd. Special Fixed Condenser; 1 Carter Jack Switch; 1 Carter Hold-Tite Jack, One Spring Open Circuit; 1 Carter Hold-Tite Jack, Two Spring Closed Circuit; 1 Carter Hold-Tite Jack, Three Spring Filament Control; 1 Carter Hold-Tite Jack, Four Spring Closed Circuit; 1 Carter Hold-Tite Jack, Five Spring Filament Control; 1 Puddin Variable Grid Leak with .00025 mfd. Condenser; 1 Federal Universal Phone Plug; 1 Federal Open Circuit Jack; 1 Federal Closed Circuit Jack; 1 Federal Double Circuit Jack; 1 Martin-Copeland Shur Grip Plug; 1 Martin-Copeland WD-11 Socket; 1 Martin-Copeland WD-11 Adapter; 1 Martin-Copeland UV-199 Socket; 1 Martin-Copeland UV-199 Adapter; 1 Martin-Copeland Pull Switch; 1 Martin-Copeland 5-point Inductance Switch; 1 Martin-Copeland Variable Grid Leak; 1 Martin-Copeland SPST Knife Switch; 1 Martin-Copeland DPST Knife Switch; 1 Martin-Copeland DPDT Knife Switch; Walnut Variable Grid Leak; Walnut Inductance Switch; Electrad Grid Leak (with clip mountings); Dubilier Micadons Type 600 (.0001, .00025, .0005, .001, .002, .0025, .003, .004, or .005 mfd.); Dubilier Micadons Type 610 (.001, .002, .0025, .003, .004, or .005 mfd.); Dubilier Micadons Type 601 (.006 mfd.); Dubilier By-Laws Condenser (.1, .25, or 5 mfd.); Premier Universal Tube Socket; Premier Radio Dial (3/16, 1/4, or 5/16 inch black or white face); Premier Universal Radio Jack, Open Circuit; Premier Universal Radio Jack, Two-Circuit Three Spring; Premier Universal Radio Jack, Filament Control Three Spring; Premier Switch Lever and 10 Points; Turney Spider Web Coil (SW-20 with .035 mihenry inductance, SW-15 with .066 MH., or SW-20 with .300 MH.).

Class C Articles

For six consecutively numbered coupons and ninety cents (\$0.90) any one of the following articles will be sent: 1 Carter 6-Ohm Vernier Control Rheostat; 1 Carter "Tu-Way" Plug; 1 Federal Panel Mount Socket; 1 Federal 6-Ohm Rheostat; 1 Federal 3-Ohm (Power) Rheostat; 1 Amperite Automatic Filament Control (with mounting); 1 Martin-Copeland Marco Rheostat; 1 Martin-Copeland Series Parallel Switch; 1 Martin-Copeland DPDT Panel Switch; 1 Martin-Copeland 7-Point Inductance Switch; 1 Martin-Copeland 9-Point Inductance Switch; 1 Martin-Copeland 11-Point Inductance Switch; Walnut Variable Grid Leak with .00025 mfd. Condenser; Walnut Variable Condenser (3-plate .00005 mfd.); Ray-O-Vac Dry Battery, 2 cells 1 1/2 volts; Dubilier Ducon; Dubilier Micadon Type 600 (.006 mfd.);

(Continued on page 9)

AN EVENING AT HOME WITH THE LISTENER IN (SEE NOTE BELOW FOR INSTRUCTIONS)

Table with columns: Station and City, Met., Monday, Tuesday, Wednesday, Thursday, Friday, Saturday, Sunday. Lists various stations like CFCA, CFCN, CKAC, etc. with their respective broadcast times.

Instructions for Use.—All the hours above are given in Central Standard Time. If your city uses Eastern Time, add one hour to each of the periods stated; if your city uses Mountain Time, subtract one hour; if your city uses Pacific Time, subtract two hours. If in addition your city is using Daylight Saving Time, add one hour to this result.

CONTENTS

Radio Digest, Illustrated, Volume V, Number 12, published Chicago, Illinois, June 30, 1923. Published weekly by Radio Digest Publishing Company, 123 West Madison Street, Chicago, Illinois. Subscription rates, yearly, Five Dollars; Foreign, Six Dollars; single copies, Ten Cents. Entered as second-class matter at the postoffice at Chicago, Illinois, under the Act of March 3, 1879.

Looking Ahead

Flewelling on a Loop Aerial—a dandy set for the summer. Read about this clever adaptation of the Flivver Super in next week's Digest, page 12. Simplex Radio Hook-Ups—Beginning next issue the first of this series of hook-ups will appear. Each piece of apparatus is pictured, as well as shown in symbol, and named. Readers fooled heretofore by the complex conventional diagrams will be surprised at the simplicity of the new series which has been deliberately designed to stop the confusion of Radio symbols. Stories about each circuit will accompany. First Steps for Radio Beginners—by Thomas W. Benson, next week, will be devoted to an explanation of the regenerative tube detector. Regeneration isn't hard to understand or control, if you learn the fundamentals. A New Super Regenerative Circuit Worth Knowing—Watch for R.D.-88 Hook-Up Diagram in the July 7 issue. This super employs but one tube, one 500 and one 1000-turn duo-lateral coil in combination with parts ordinarily included in a single circuit tube receiver. Many Requests for a Repeat of the Reinartz Radio Frequency Circuit—will be satisfied by its republication next week. This hook-up shows how to add two steps of R. F. to your Reinartz set. Portable Set Series, Part III—will be devoted by H. J. Marx to panel layouts for the three different circuits given in Part II this week.

Have a Copy with You on Your Vacation WHEN YOU WANT Radio Digest YOU WANT IT! BE SURE OF YOUR WEEKLY COPY, BY SUBSCRIBING NOW SEND IN THE BLANK TODAY Publisher Radio Digest, 123 West Madison St., Chicago, Illinois. Please send enclosed check M. O. for Five Dollars (Six, Foreign) for One Year's Subscription to Radio Digest, Illustrated. Name Address City State

RADIO STOPS AUTO?

(Continued from page 1) As if by command, the twenty drivers left their cars simultaneously to make an examination. Their efforts to start proved futile, and why they could not tell. Not one of the engines would spark.

Motors Stopped by Radio At that point the driver of the leading car explained that the experiment was over and that it had been a complete success, since the German Radio station at Nauen had succeeded in bringing each of the twenty cars to a stop by demagnetizing its magneto with the aid of a new form of Radio wave.

"Startling, indeed, and yet perfectly plausible and quite in accordance with contemporary scientific research in the Radio field is this experiment," declared Dean Winn. "This mysterious power transmitted through equally mysterious waves is, perhaps, not so much a new discovery as the perfection of a method of transmission of power by Radio, over which scientists in Europe and America have been working for some time. It may mark only a new step in the line of invention, which has enabled the United States navy to operate vessels in the open sea from Radio stations on shore."

Similar Experiments Made Here "Similar experiments as the one here explained have been carried out successfully even in the laboratory of the Detroit Institute of Technology," Dean Winn declared.

While unwilling to regard this power as mysterious or to describe the German experiment as something new, Dean Winn expressed full faith in the reported experiment and has great hopes in the future development of Radio transmission of power, and its possible revolution of the methods of modern warfare.

"The same waves which brought to a standstill the twenty German automobiles could," Dean Winn says, "bring to a halt batteries of artillery, tanks, fleets of ships and squadrons of airplanes. It is premature," Dean Winn says, "to speak definitely of future warfare in the light of this new development. Development in two directions may, however, be expected, especially since experimental work in both directions has been started."

Other Developments Expected

"There may be further developments in the direction of self-ignition engines, which would do away entirely with the magnetos and electrical appliances which go with the machinery of warfare. So, on the other hand, there may come new developments in the construction of powerful Radio stations capable of generating magnetic fluxes of tremendous strength, not only to demagnetize war engines, but also to neutralize demagnetizing Radio stations.

"No one can tell what the future may bring, but it seems to me quite plausible that to the deadly gas duels and bacteria duels of the future war, the apparently harmless duel of electric waves, shot from high towers, will have to be added, in view of the German experiment.

American Export Skeptical

According to an automobile ignition expert, most makes of American cars are equipped with single ignition systems—depending upon generator-charged storage batteries and not upon magnetos for ignition. These would not be stopped by this mysterious Radio wave, granted that the thing that does the stopping is temporary paralysis of the magnetic field of the magneto. Most European cars are magneto-equipped, as are certain American cars.

The device, if able to stop magneto-equipped motor cars, would also be able to stop most airplane engines, according to flyers, because of the fact that similar equipment is used. The Liberty engine, operating with a special ignition system, which may be used with a storage battery, would be able to continue operation, because the temporary-paralysis of the magnetic field, if that is the cause, would not stop the flow of current from the battery.

Say Invention Buncombe

Several Chicago electrical experts belittle the invention. They say that it is effective for stunt purposes only, and then co-operation of the proposed victim probably would be necessary.

Followers of Radio development, who have been discussing the reported invention, share the theories of Paul Nearl, engineer, who said the device can be easily "beaten" by encasing the magnetos in an iron shield and grounding the shield.

"Your Move"—Radio Chess Latest Steamer Pastime

NEW YORK.—Radio chess as a pastime for ship passengers has been inaugurated by the steamships Western World and American Legion, in the South American service. The Western World arrived recently with reports of a three-man match between teams on the two ships, which passed each other a few days ago.

The game was called when the steamers were 1,200 miles apart, because their transmitters wouldn't carry any farther. As both teams claimed the victory, decider has been left to the Buenos Aires Chess Club.

WORD SCRAMBLER ASSURES PRIVACY

NEW "TALK BRIDGE" BALKS LISTENERS-IN

Invention Makes Conversation Unintelligible to Outsiders; Clarifies Tones for Recipient

By Evelyn Lanzius

NEW YORK.—Privacy has been made possible in Radiophone conversations through a device that "scrambles" words at the sending end, so that to any one listening in they are unintelligible, and clarifies the tones to the person for whom the message is intended, it was announced recently by the American Telephone and Telegraph Company.

The invention has been used successfully, it was said, over a thirty-mile stretch of ocean between Los Angeles and Catalina island.

The problem of obtaining privacy in Radio conversation was solved by engineers of the Bell system, it was asserted, partly as a result of the post-war scarcity of cables for undersea use.

Two Way Talking Possible

"The Radio 'talk bridge,'" said an engineer of the company, "which has given satisfactory transmission across the thirty-mile gap of water night and day since 1920, was designed to permit two-way talking between the mainland and the island.

"Heretofore talks over the Catalina island Radio link have been 'picked up' by amateur receiving stations in the region. The privacy system was designed to remedy this. It is not claimed that the new system is absolutely secret. An ingenious person might devise a set which could listen to the system, but such a set would be much more complicated than the ordinary set.

Island Connected to U. S.

"The new Radio attachment before putting the messages on the air will distort or 'scramble' them, and no receiving set which is not specially designed to 'unscramble' them can obtain anything intelligible.

"At the time the apparatus was installed a submarine cable could have been laid joining the island and mainland, which would have supplied a better grade of service at less expense, but the conditions at that time, which grew out of the war, were such that the manufacture of cable would have involved a long delay."

1,100 MUSICIANS GIVE CONCERT FROM WJAX

Station Broadcasts Massed Bands at Grotto Conclave

CLEVELAND.—"Music filled the air" literally and figuratively, when twenty-five Grotto bands got together recently in Public Hall, and their offerings were broadcast by WJAX, the powerful station of the Union Trust Company.

The occasion was the annual conclave of The Grotto, with Cleveland as host to 50,000 Prophets and their ladies. Twelve thousand people were in immediate attendance at Public Hall and the rest of the United States listened in and compared the band from Boston with those of New Orleans and Kansas City. E. G. Johnson, the "man with the million dollar voice," was the announcer.

Special circuits were arranged between the studio and Public Hall and credit is due Chief Operator J. M. Thorburn, who had his broadcasting apparatus tuned so nicely that even the applause and comments of the audience in the immense auditorium were floated out on the crest of "The Wave from Lake Erie." So the "stay at homes" got an earful and were with the Prophets in thorough enjoyment of the program.

Weak signals in a Radio receiver are sometimes due to poor ground connection.

POLICE MATRON BUYS OUTFIT FOR LOST KIDS

HOBOKEN, N. J.—Lost children who find their way to Hoboken will find little time to cry for their mothers from now on. Mrs. Mary Garrick, police matron at Hoboken police headquarters, who has mothered more than a thousand lost children since she has been a police attendant, has bought a Radio outfit for the purpose of entertaining lost kiddies until their mothers arrive.

PHILLY HAS ITS FIRST 'BROADCAST WEDDING'

PHILADELPHIA.—This city had its first broadcast wedding recently when Frank Nickel, Jr., assistant operator of Station WIP, and familiarly known the country over as announcer "DX," took Miss Lillian Louise Everit for his bride. It was solemnized at the Holy Trinity Chapel, Twenty-second and Spruce streets. The church is well-known to Radiophans, as church services are broadcast from it.

DETECTS PAIN OF INJURED FLOWER

SUPER SET ALSO RECORDS HUMAN DISEASE

Delicate Instrument Delivers "Message" of Cancer; Horn Squawks When Leaf Is Torn

SAN FRANCISCO.—The pain experienced by a flower when it is torn, detection of presence of diseases, and other astounding performances have been recorded by use of the super Radio set, Dr. Albert Abrams, who pioneered the use of Radio activity, declared here recently.

The super Radio used by Dr. Abrams in a series of tests here is attached to what he calls a reflexophone, which, Dr. Abrams explains, catches from the air the vibrations of diseases and records them by means of delicate tuning methods.

On a table were arranged the neat boxes of the reflexophones with their dialed covers. Wires connected the reflexophone to tiny instruments arranged on a board, whereon three lighted bulbs glowed warmly, and from which rose a magnavox horn. The super Radio was equipped with an antenna, a delicate looking rod attached to the set by a black cord.

This machine, Dr. Abrams believes, will some day be perfected to the point where it will stand on street corners and in stores, so that those who care to may drop a coin in the slot and ascertain what ails them.

Cancer Radiates Waves

The first test performed by Dr. Abrams was to record the vibrations of cancer. The moment the antenna rod approached a bottle containing a cancer in alcohol, the horn gurgled audibly. When the bottle was removed and the rod adjusted, the horn squawked again, but after a magnet had been passed over the spot, the Radio failed to respond.

The Radio recorded the message broadcast by the cancer, Dr. Abrams explained. "The cancer communicated a portion of its energy to the spot where the bottle had stood, hence the same reaction. The magnet 'sterilized' the spot, hence the reaction."

When the leaf of a nasturtium was torn the horn responded. Dr. Abrams then cut the leaf, and there was no reaction. Another leaf, held over the mouth of a chloroform bottle, was similarly torn and cut, but without the Radio recording the action.

"Plants broadcast waves of Radio activity," Dr. Abrams explained. "Tearing hurts the leaf, cutting is painless. When the plant is influenced by chloroform it feels no pain."

Quaker City Goes Back to Her Silent Nights

Stations Return After Fans Clash Over Issue

PHILADELPHIA.—When the new wave lengths went into effect the matter of silent nights was left alone because it was felt that with the wide difference in local wave lengths owners of tube sets would experience little difficulty in tuning in distant stations. It is claimed that some selfish fans, whose sets are not selective enough to tune in outside stations, have deluged several newspapers with letters claiming that Philadelphia broadcasting stations are "hogging the air." One newspaper printed all the letters, which brought in a deluge of letters from those who wish silent nights and those who do not.

The upshot of the entire affair is that Station WIP has announced that it will have silent night every Thursday at 9:30 p. m. Stations WOO and WDAR will begin a new schedule, and will broadcast only two nights a week. Station WFI is considering a summer schedule and announcement will be made soon.

FISHING ON THE ETHER BANKS



You can't beat fishing for the stray DX plants, even with a fishing rod. Eleanor Osgood, New York City, however, cannot decide which sport is best, so does both at the same time. Eleanor has the right idea, you'll agree, or did you ever wait for a bite? © K. & H.

SEE STATIC WATERLOO IN VERTICAL ANTENNA

Experimenters Test Scheme with Kite Balloon Aerial

BURBANK, CALIF.—Is it possible that the vertical antenna may solve the problem of static interference?

This question is prompted by tests recently made here by R. W. Coburn and Roy Knabenshue, who sent up a kite balloon to which they had attached an antenna wire to their receiving set.

With the balloon up 200 feet, the experimenters say they heard several broad-

cast concerts with a singular absence of the familiar grating noises commonly resulting from atmospherics.

Coburn and Knabenshue intend to construct a larger balloon and send it up higher for the purpose of experimenting further with the vertical antenna, both in transmitting and receiving.

Coast Guard Praises Air Compass

WASHINGTON, D. C.—The reports from the various vessels of the Coast Guard indicate that the Radio compass is a valuable aid in locating their positions at sea. The Radio compass has proven invaluable to the Coast Guard in making contact with other vessels, especially those in distress calling for assistance.

THE ANTENNA BROTHERS

Spir L. and Lew P.

A Suggestion for the Fourth

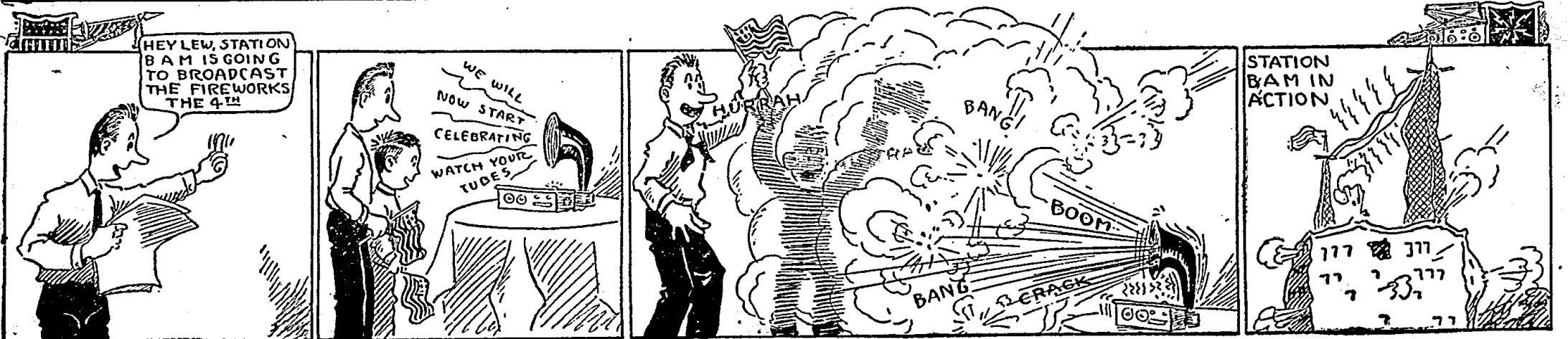

RAID REVEALS RUM RUNNERS' AIR PLOT

SEIZE RUM, AMMUNITION, RADIO SET

Dry Agents Convinced Law Breakers Used Ether Phones to Keep Watch on Authorities

NEW ORLEANS, LA.—Law breakers, always abreast of the times, are reported by police and federal dry agents to have employed Radio as a means of learning the whereabouts of prohibition enforcement officials, of communicating with rum ships at sea and of keeping in touch with confederates along the Gulf of Mexico, the almost impenetrable bayous of Louisiana and their supposed headquarters in New Orleans.

That was declared to have been proven with the seizure of a complete Radio set, a vast amount of liquor, arms and ammunition and the arrest of a man giving his name as D. H. Kirkley, 27 years old, 1325 Pyrtania street, New Orleans. Kirkley was arrested late Friday on the shell road near the Kenilworth plantation in St. Bernard parish.

Agents report they arrested Kirkley after an exciting race and that they found thirty-five quarts of whisky in his car. They then raided a camp on De La Croix Island, where the Radio set was reported to have been discovered.

Radio Seized at Camp

Police say Kirkley obtained his supply of liquor at the camp, where they said they discovered thirty-nine cases of whisky, two shotguns, a lard pail filled with loaded shells and the Radio set.

Residents of De La Croix were questioned. They said every day or so some one would appear at the camp and operate the Radio, but they said they doubted if they could identify the mysterious visitors.

Federal agents believe the Radio set was used not only to communicate with rum runners in the Gulf, but on Lake Ponchartrain, access to which is possible by numerous obscure bayous and passes; is attractive to smugglers operating between Cuba and other points and New Orleans. Once safely in the lake, the liquor is said to have been brought to the camp, where it was distributed in automobiles and trucks.

While only one arrest was made, others are expected.

CFCN TO PHONE FIGHT

(Continued from page 1)

a distance of more than 230 miles, and broadcast from there.

At the present time directors of the fight and those in charge of arrangements and advertising are conducting a thoroughly efficient and extensive campaign of publicity for the battle, one of the biggest sporting events of the decade on the American continent. And again Radio has leaped into prominence in this respect. These publicity agents, ever on the alert for some new and novel means of bringing their wares to the attention of the wide world, are capitalizing Radio for this purpose.

NEW HAZELTINE NEUTRODYNE PRINCIPLE MAKES GOOD TWO STEP RADIO FREQUENCY AMPLIFIER

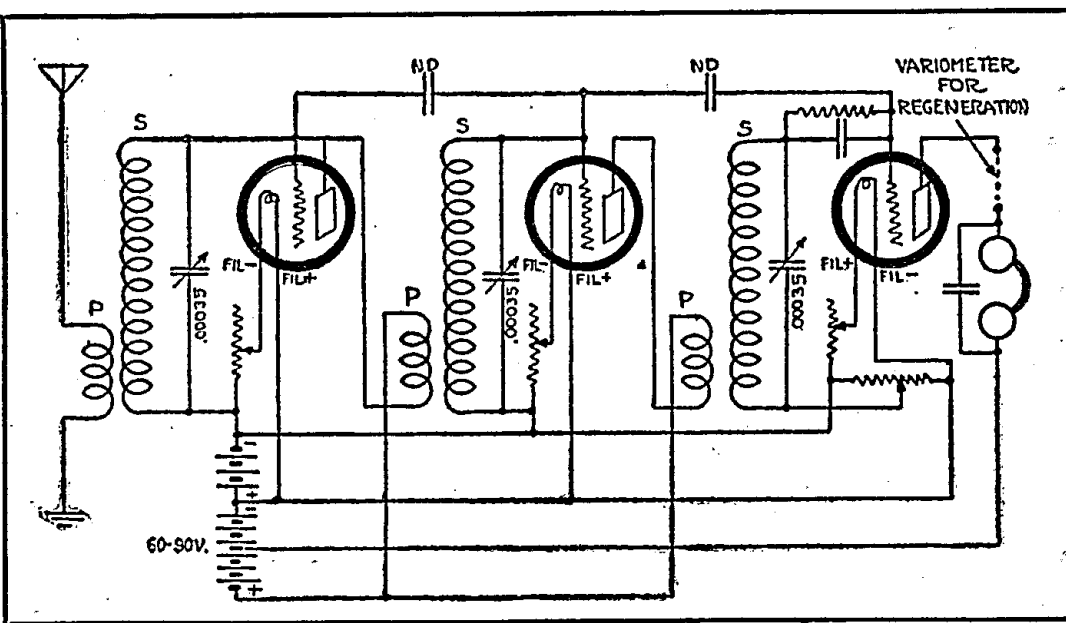

A RECENTLY developed circuit, known as the Hazeltine Neutrodyne, is credited by its originator to be capable of developing an amplification ratio of one million to one, using two stages of Radio frequency amplification. The principle is adaptable to all hook-ups in which Radio frequency amplification may be used. Regeneration may be used and all howling from the Radio frequency amplification eliminated. The secret of the hook-up centers in the construction of the three "neu-

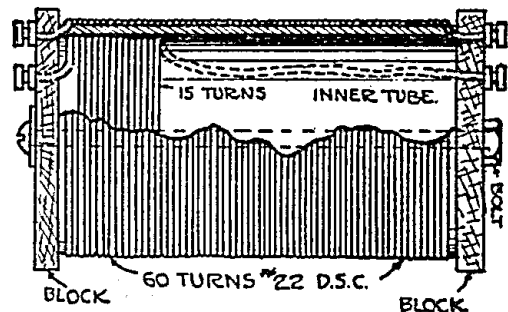

troformers" (R. F. transformers) and the "neutrodons," a form of small condenser shunted between the grids of the three tubes. These neutrodons tend to neutralize the grid-to-plate capacity between the grids and plates of the tubes and thus eliminate the danger of oscillation or howling.

The neutroformer consists of two cylindrical tubes, either fiber or composition, 3 1/2 inches in diameter by 3 inches long and 3 inches in diameter by 3 inches long. Fifteen turns of No. 22 double silk covered wire are wound on the small tube and 60 turns of the same size wire on the large tube. The small tube is then placed inside the larger one, so that the windings of

both are parallel and in the same direction. The coupling between the two coils is fixed. In order to keep the two tubes in place, a block is placed at both ends and a fiber rod, threaded at both ends, passed through both blocks and tightened down by means of two nuts.

The construction of the neutrodons is very simple. Obtain a foot or two of No. 8 copper wire and some hard rubber tubing in which the wire will fit tightly. Two pieces of wire are inserted in the tube, as shown by the diagram, and a brass sleeve fitted over the hard rubber tube. Care should be taken to see that the two pieces of wire do not touch each other inside of the tube, and the brass sleeve should be free to move.



In hooking up the various parts, great care should be exerted to see that the diagram is strictly carried out. The neutrodons must be isolated from the rest of the apparatus, so that no capacity or inductive coupling will exist between them and the rest of the apparatus. The neutroformers should be offset at an angle of 45 degrees to eliminate any possibility of inductive relation existing between them.

To set the values of the neutrodons, light all the tubes and tune in a loud sta-

Long Distance Crystal Set

We receive programs from Atlanta, Minneapolis, Davenport, Fort Worth, Dallas, Kansas City, St. Louis, Denver on Crystal without batteries. Usual crystal set requires only easy, inexpensive changes. Send stamp for further information or \$1 for copyright drawings and instructions. Everything clearly explained. Satisfaction GUARANTEED. Leon Lambert, 501 South Volutsia, Wichita, Kan.

The trick is in the Coil
NO STORAGE BATTERY REQUIRED
No Radio Frequency Transformer used. Not Super but DOUBLE Reflex Regeneration. Works local without antenna or ground, and brings in the "FAR AWAY ONES" with more volume than you ever thought one tube could deliver. Money Order for 25 cts. brings easy to read diagrams and all information. Address: JACK PRATT, 508 Railway Exchange Bldg., Chicago, Ill. P. S.: Its Radio Golf Record is 119,000 miles. First Trial Picked Up Havana from New York

tion. Then turn off the filament of the first tube and adjust the brass sleeve of the first neutrodon until no signals can be heard in the phones. Turn up the first filament and go through the same procedure with the second tube. Finally it will be well to seal the adjustments of all three neutrodons by means of a few drops of hot sealing wax.

UV-201 tubes are recommended and a fairly high plate voltage used: 60 to 90 volts. The detector, however, is tapped off at 18 volts.

If regeneration is desired, a variometer may be inserted in the plate circuit of the detector tube.

The dimensions given for the neutroformer are for broadcast reception. If it is desired to receive amateur work, the number of turns should be reduced to 10 and 40.

A word about tuning. The adjustment of the second stage and detector variable condenser is usually the same, while that of the first stage will vary as the capacity and inductance of the antenna being used. To tune in a station, the second stage and detector are set and the tuning done with the condenser of the first stage. A final adjustment is accomplished by tuning the detector circuit, second stage, and first stage in the order given. The potentiometer in the detector circuit is almost indispensable for good results. The set is very constant, and once the adjustments are found they will remain the same for any length of time.

Noise in Paris Jars Time Devices to Inaccuracy

PARIS.—The international time of day is broadcast twice a day from the Paris Observatory, located not far from the Latin quarter.

But the noises of the city are so great and the vibrations from street traffic so noticeable that the requisite accuracy is becoming impossible, and the director of the institution says he must move his instruments to the peace and quiet of the country.

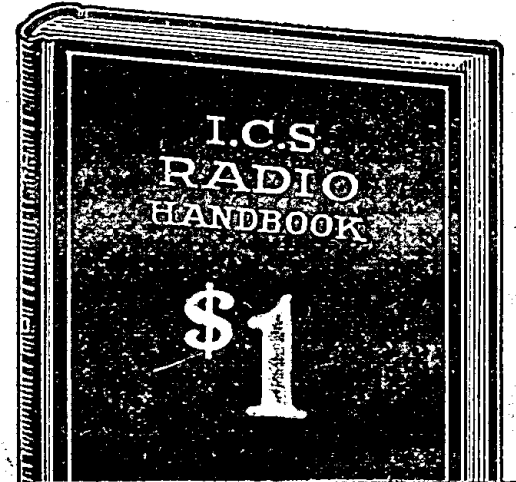

Every Radio Fan Should Have This Book

LIKE a little radio encyclopedia, this I. C. S. Radio Handbook is packed with concise, sound information useful to everybody from beginner to veteran hard-boiled owl. It starts with simple explanations of radio phenomena and leads you along gently until you can understand the most technical diagram.

You may dip into it at random, or hunt up special information you want, or read it right through. Different types of receiving and sending hook-ups are explained; proposed insurance regulations; lists of broadcasting stations; radio compass stations; interesting experiments; definitions; codes and symbols; technical data and thousands of suggestions for getting more pleasure out of radio.

A pocket course in radio! Every page tells you something useful, and there are 562 pages; hundreds of illustrations and diagrams. It is the biggest dollar's worth in radio, and will save you from wasting money on things that don't work.

Send \$1 to-day and get this 562-page I. C. S. Radio Handbook before you spend another cent on parts. Money back if not satisfied.

TEAR OUT HERE
INTERNATIONAL CORRESPONDENCE SCHOOLS
Box 8277, Scranton, Penna.
I enclose One Dollar. Please send me—post-paid—the 562-page I. C. S. Radio Handbook. It is understood that if I am not entirely satisfied I may return this book within five days and you will refund my money.
Name.....
Address.....

The PERFECT Broadcast Receiver—

All of the joys of radio may now be yours without outdoor antenna, loop, or storage battery, with the



Licensed under Armstrong U.S. Pat. No. 1,113,149

A SILK-COVERED WIRE but 20 feet long, supplied with this Receiver, does the work of the unsightly outdoor antenna, or loop. This wire may be concealed behind the picture moulding or run along the baseboard.

Ask your Dealer, today!

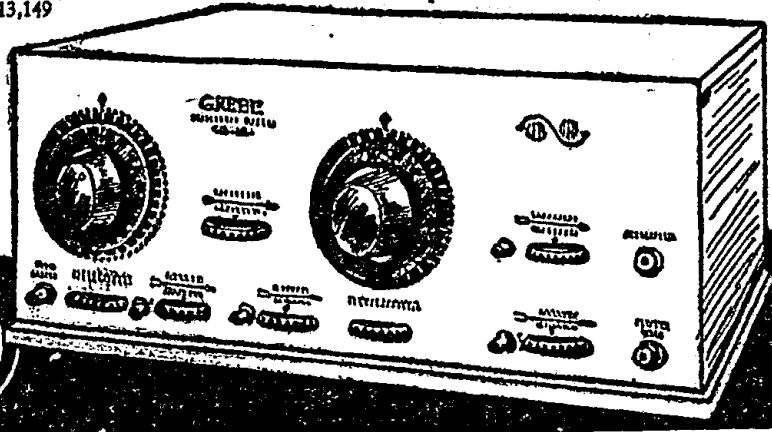

"CLEARPHONE" AND "RADARIO" NEW DEVELOPMENTS

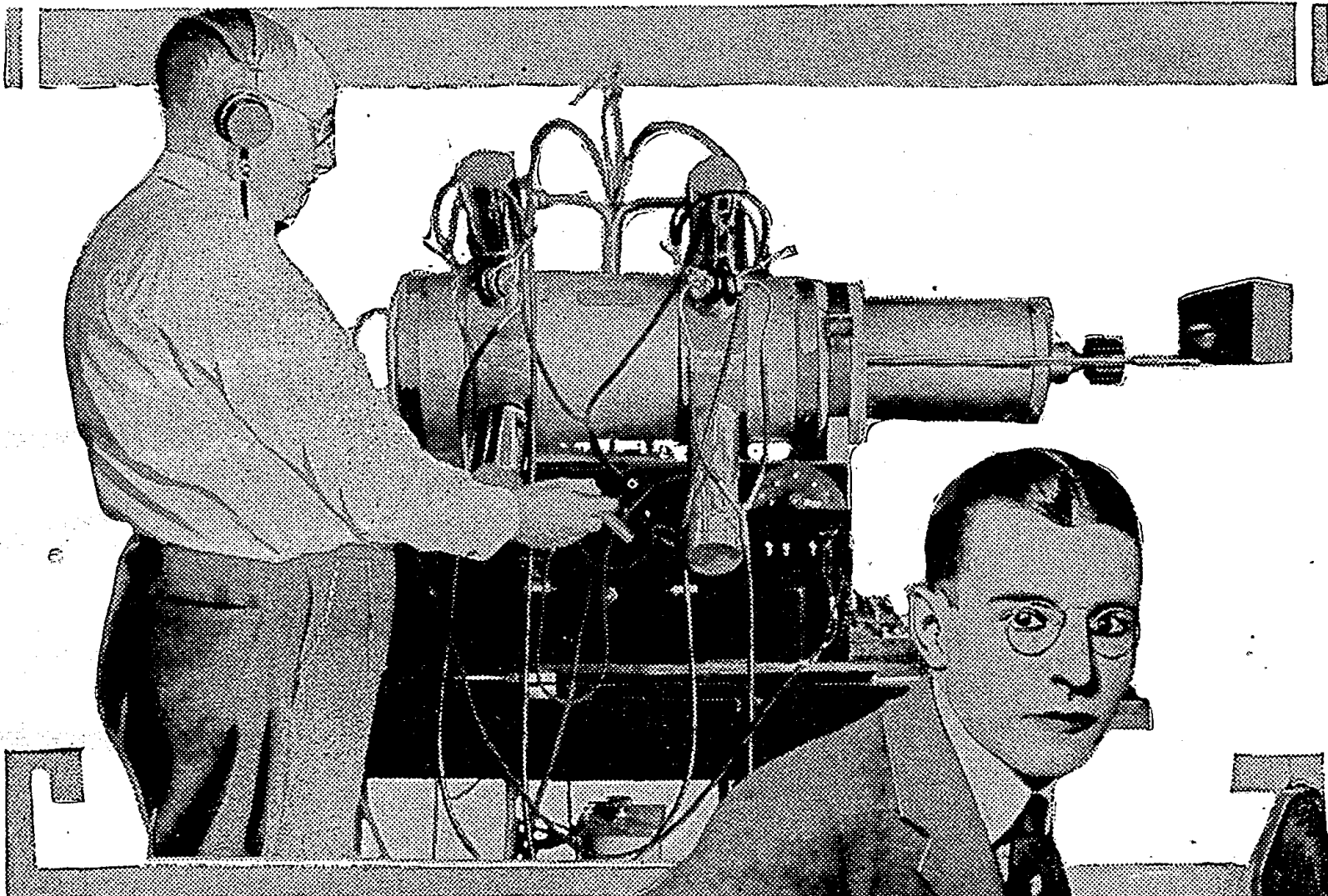

W. J. Scott, the inventor, and his "Clearphone," which is designed to eliminate the static in reception, especially in Radio telegraphy. (See article in fourth column.) © Int.

DEVELOPS DRAMAS FOR BROADCASTING

FIRST ETHER DRAMA BIG HIT AT STATION WDAR

Clyde Agnew Criswell, Specialist in New Technique—Tax on "Prop's" Ingenuity

By W. E. Johnson
 PHILADELPHIA.—Clyde Agnew Criswell has developed a technique for writing dramas especially for Radio. His first attempt, "The Secret Wave," a three-act play of the melodramatic type, was broadcast from WDAR, Lit Brothers, in Philadelphia. Mr. Criswell says the play pleased so well that the station has received more than 1,000 letters asking for more. He is credited with having written the first Radio drama, and holds a copyright on it.

"Radio dramas," he said, "will find a permanent place on broadcast programs in the future. When the moving picture was invented it was found that dramas written for the stage were not suited for filming, and new ideas had to be used. "Until such time as the moving pictures and Radio have been synchronized, and this time is bound to come, this new technique will have to be used. A dialogue must be used that will convey to the listeners in exactly what is taking place. Each sentence must convey a move or action. In the stage play, the audience sees every move, and also hears; in the motion picture the audience sees and also reads the captions or sub-titles, but the Radio audience, which is invisible, must follow the action of the play by words. Everything must be through suggestion.

"Everything," Mr. Criswell said, "must be conveyed so forcibly that the listener in really beholds the characters and knows what sort of setting is used."

Property Man Originates
 The Radio drama has developed a new type of genius, thinks Mr. Criswell. He is the Radio property man.

"Just as the movies and the legitimate stage have property men, so, too, must the Radio drama or play have a property man. And I think his job is much harder, because he must adapt himself to the new art.

"For instance, many amusing things happened while we were broadcasting tests of 'The Secret Wave.' We found that by discharging a regular type revolver it gave a long whistling noise instead of the sharp staccato sound that was wanted. What we did was to blow up a paper bag and burst it. In the third act was a revolver duel, and to distinguish between the two shots, we had to use the paper bag stunt for one shot and burst a toy balloon for the other. This

gave the listeners in the conception of two different shots."

Automobile Sounds Faked

There is also an automobile in this act. The part required closing of the door, blowing the horn, starting the motor, shifting the gears and using the auto cut-out. "Of course," he said, "the blowing of the horn was easy, but we were put to our wits' end to get the other necessary sounds. This is how we did it. For slamming the door of the auto we had a regular automobile door; for starting the motor we used a vacuum cleaner in front of the microphone; for shifting gears, we had a regular Ford gear-shift in front of an electric fan to give the engine effect, while for using the cutout, we held a stiff piece of cardboard against the electric fan.

"These stunts are known as graphic sound, and the property man has a hard job on his hands to have everything record exactly as it should sound."

Mr. Criswell claims that you must "walk on eggs" to please the Radio audience with a drama. In the regular theater the man has the choice of picking a play from a number, and it is the same with the movies. The minister will go to the show that pleases him, while the gambler will go to a play that attracts him. All of the objections must be taken into consideration, because in Radio everybody listens in.

WBZ Employes Organize Station's Own Orchestra

SPRINGFIELD, MASS.—Station WBZ of the Westinghouse Company, now has its own orchestra, known as the WBZ Concert Orchestra. This will supplement concerts given from the station by artists of Springfield and vicinity, and is composed of employes of the Westinghouse plant here. It is directed by S. J. Fairfield, who has been a conductor of bands and orchestras for twenty-five years. At present it is planned to give concerts three times weekly, the programs being arranged as dinner concerts, Monday, Wednesday and Friday, from 6 to 7 P. M., Eastern Standard Time.

CLEARPHONE KILLS STATIC IN SIGNALS

EXPERTS PUTTING INVENTION THROUGH TESTS

Results to Be Secret for 2 Years; U. S. to Take Out Patent on Device

By L. M. Lamm

WASHINGTON, D. C.—Radio experts of the Navy Department are experimenting with a so-called "Clearphone," which is claimed to either entirely, or at least assist in clearing static from signals. The new apparatus is the invention of W. J. Scott, who is a chief electrician in the navy, stationed for many years at the Norfolk Navy Yard, but now detailed to the Research Laboratory of the navy.

Navy officers and other officials of the department who have charge of the experimental work refuse to discuss the new invention which it is believed will revolutionize Radio sending by telegraph but will have nothing to offer in connection with Radiophony.

Development Confidential

The Navy Department has been doing experimental work in connection with the "Clearphone" for some time, it has just been learned, but nothing has been given to the public on the experiments and nothing will be made public until some two years after the apparatus has been successfully used by the department. The patents, it is understood, will be taken out in the name of the Government, and a

C. A. Criswell, Philadelphia author and "Radario," who is responsible for a new departure in broadcasting. He writes Radio dramas especially for broadcast production. (See article in first column.) © Keystone

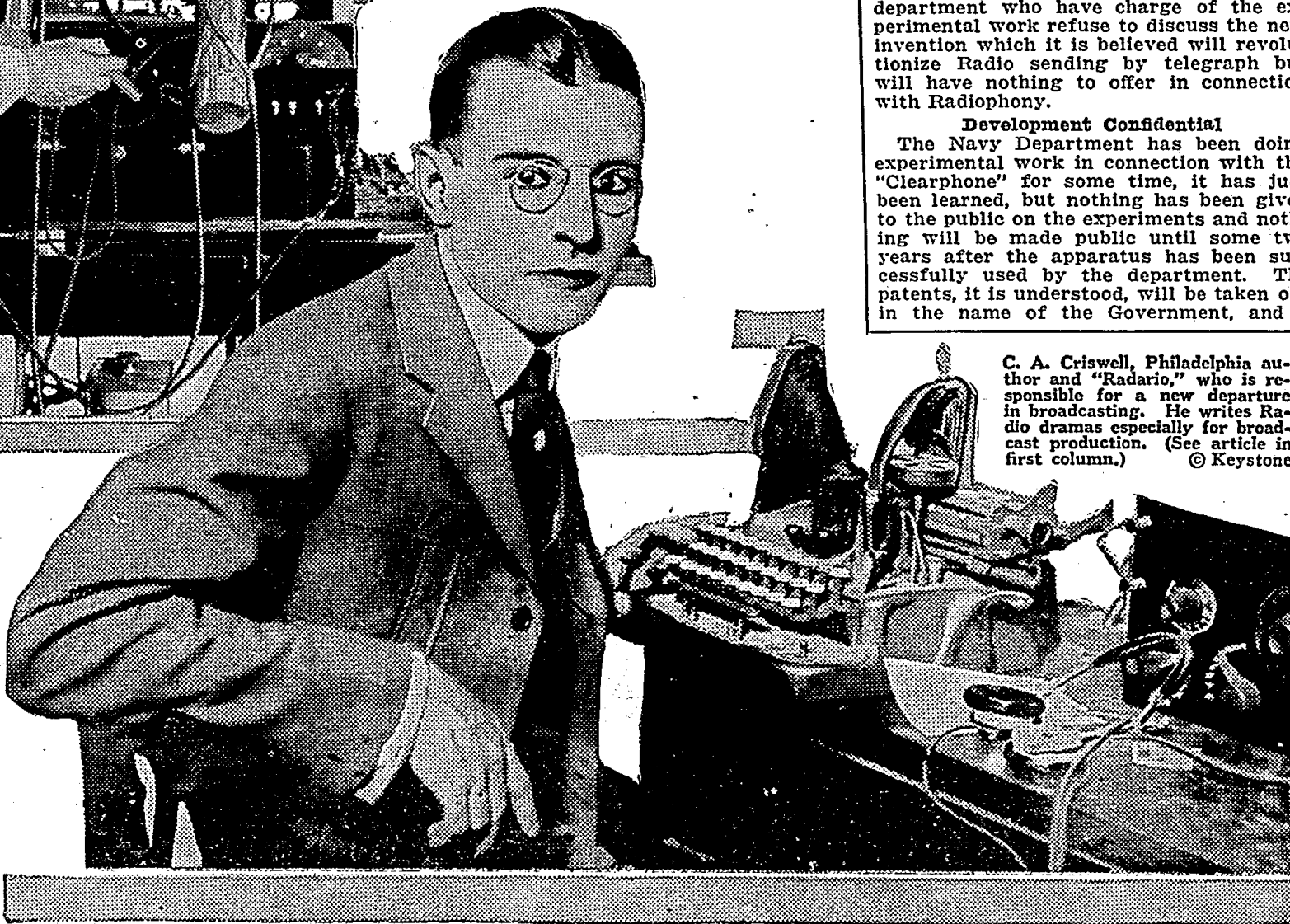

Standard Waves for Set Check-up

WWV to Enable Amateurs to Calibrate Wavemeters so as to Check Transmitting Outfits

WASHINGTON.—In an effort to permit Radio operators and fans to check their wavemeters and instruments on standard waves, the Bureau of Standards will transmit standard wave lengths commencing at 10:55 p. m., Eastern time, each night, on July 17, August 15, September 13 and 28 and on October 7.

On the last date, WWV will enable amateurs to calibrate their receiving and transmitting sets, since the land covered will be from 222 to 150 meters, the signals being sent between 1:50 a. m. and 3:41 a. m.

The schedule follows:

Date—	Kilocycles, Frequency	Wave Length, Meters
July 17	425-1500	705-200
Aug. 15	425-1500	705-200
Sept. 13	425-1500	705-200
Sept. 28	500-1700	600-176
Oct. 7	1350-2000	222-150

In continuation of the established practice, the Bureau will transmit the call signals "WWV" both in Radiotelegraph and Radiotelephone, each wave length occupying about nine minutes of time.

Gold-Mounted Receivers Are Royal Wedding Gift

LONDON.—Among the countless wedding presents received by the Duke and Duchess of York was a wonderful gold-mounted Radio receiving set. It is a portable loop receiver, mounted on a mahogany tea wagon, complete in every detail, with loud speaker and even a charger for the storage battery on the shelf beneath.

Never place a lightning switch indoors.

policy has been adopted at the Navy Department which precludes the giving of any experiment to the public until after two years has elapsed.

In addition to the work which the navy experts have done on the "Clearphone" it is understood that Mr. Scott worked for several years on it before bringing it to the attention of the navy officials. The experiments so far, it has been learned, look as though the apparatus would be a success.

"RADIO BABY" NAMED FOR BROADCAST PLANT

WGY, Schenectady, Is Honored by Wisconsin Family

SCHENECTADY, N. Y.—WGY, located here, has been honored by a Wisconsin family. A brand new baby has been named after it. He is Wallace Gordon Yadon and he lives in Delavan, Wis. His father has written the station:

"We have a baby called the 'Radio Boy,' because we have named this child after your station, which indicates that not only the child is a favorite but that your station is our favorite. We only hope that you would broadcast twenty-four hours daily.

"The boy's name is Wallace Gordon Yadon. The receiving set has been placed at the hospital for the last five weeks, and even the little fellow is getting so he can recognize the announcer."

France Leads Europe with Most Powerful Equipment

PARIS.—While the United States has been carrying on an intensive campaign in broadcasting and the use of Radio by amateurs, France has been hard at work developing its commercial Radio business through private enterprise. Today France has the largest, most efficient and most powerful equipment in Europe. Unlike England, France took the opportunity during the war of developing this new means of communication.

YANKS AND JAPS IN RADIO RIGHTS MESS

HARBORD MEETS OFFICIALS AT WASHINGTON

Minister Schurman Remonstrates with China for Expulsion of Yank Firm

WASHINGTON, D. C.—G. Harbord, president of the R. C. A., was in recent conference with state department officials, and, while no statement as to the nature of the conversation was forthcoming, it was understood to have had to do with efforts of the Federal Telegraph Company to obtain from the Chinese government authority to complete and put in operation its radio stations in China.

The only authoritative statement made at the department was that there had been no recent Chinese development. It was understood that the Washington government has as yet been unable to induce the Chinese authorities to grant equal opportunity and land rights to the Federal Company, although the latter has invested more than \$15,000,000 in its Chinese enterprise.

Japs Can't Jump Ocean

A Japanese Radio company is also at work in China but has not yet established communication across the Pacific owing to mechanical difficulties with its equipment. Pressure from this source via Tokyo is generally credited with having caused the Peking authorities to defer action on the request of the Radio Corporation for the granting of privileges necessary to the completion of its projects in China.

There is reason to believe that Minister Jacob G. Schurman has remonstrated with the Chinese authorities over what amounts to an expulsion of the American company in favor of the Japanese concern and that he has pointed out that the Washington government expects the Peking government to adjust matters so that there can be equal opportunity in development of trans-Pacific communication and the furtherance in commercial intercourse with China.

Use Remote Control to Send Out Calgary Music

CALGARY, ALTA.—CFCN is now broadcasting every Monday night the Military Band at the Capitol theater here. The concert is broadcast by a system of remote control which has been perfected by W. W. Grant. The orchestra is located in the heart of the city and the broadcasting station located on Crescent Heights, a mile and a half distant. Cable lines run from the theater to the station.

The London Daily Mail has a broadcasting station at The Hague, Holland, and it has been reported as heard in this country. The call letters are PCGG.

SOMETHING NEW

A real loud talking detector made of "B" Metal 100% superior to any crystal. Puts new life into your set. Guaranteed for one year. It's the cheapest in the long run. **50c**

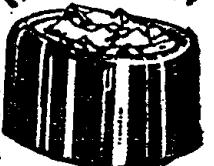

Sold by all live dealers, or can be ordered from the **B-Metal Refining Co.** 3134 Trumbull Ave. Detroit, Mich.

Amsco Rheostats

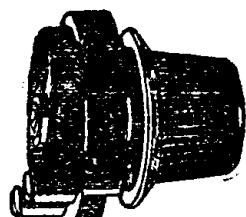

Guarantee an unusually uniform and steady contact. For base or panel mounting. Condensite base, high-grade resistance unit, attractive knob. Adjustable shaft to any thickness panel. 6 Ohms.....\$1.00; with dial.....\$1.25 20 Ohms..... 1.25; with dial..... 1.50 (For UV-201A Tubes) 50 Ohms..... 1.30; with dial..... 1.55 (For UV-199 Tubes)

At All Good Dealers **AMSCO PRODUCTS, INC.** Broome & Lafayette Sts., New York City

PORTABLE RECORDS? SEND 'EM IN—

By the Contest Editor

WHAT do you think of this list of portable set records? These Radiophans are not going to let the summer heat keep them from listening in. They have their outdoor sets all ready for the summer and it looks as if they are not going to miss any of the interesting programs to be broadcast this season. If you have a portable set, read over the rules given below, and send in your records. Let other Radiophans know what you are getting on your outdoor set.

The first list of portable record holders appears below:

Station—Miles Away—Who Heard It
CFAC—1775, M. A. Acheson, Houston, Tex.
CJCA—1275, M. A. Acheson, Houston, Tex.
CJGC—1225, M. A. Acheson, Houston, Tex.
KFEY—1650, M. A. Acheson, Houston, Tex.
KGG—1825, M. A. Acheson, Houston, Tex.
KDKA—350, W. R. Clark, Jr., Bridgeport, Conn.
PWX—1375, W. R. Clark, Jr., Bridgeport, Conn.
WBU—750, W. R. Clark, Jr., Bridgeport, Conn.
WCAE—950, W. R. Clark, Jr., Bridgeport, Conn.
WCAU—1350, M. A. Acheson, Houston, Tex.
WCAX—1600, M. A. Acheson, Houston, Tex.
WCAZ—1050, M. A. Acheson, Houston, Tex.
WDAK—1525, M. A. Acheson, Houston, Tex.
WDAP—750, W. R. Clark, Jr., Bridgeport, Conn.
WDAY—1200, M. A. Acheson, Houston, Tex.
WFAG—1525, M. A. Acheson, Houston, Tex.
WGL—1350, M. A. Acheson, Houston, Tex.
WHAL—1100, M. A. Acheson, Houston, Tex.
WLAS—675, W. R. Clark, Jr., Bridgeport, Conn.
WLP—1350, M. A. Acheson, Houston, Tex.
WJAP—1225, M. A. Acheson, Houston, Tex.
WJAR—1600, M. A. Acheson, Houston, Tex.
WKC—1275, M. A. Acheson, Houston, Tex.
WKY—1375, W. R. Clark, Jr., Bridgeport, Conn.
WLAW—1450, M. A. Acheson, Houston, Tex.
WMAZ—1425, M. A. Acheson, Houston, Tex.
WOC—900, W. R. Clark, Jr., Bridgeport, Conn.
WPAI—1000, M. A. Acheson, Houston, Tex.
WPG—975, M. A. Acheson, Houston, Tex.
WSAI—800, K. N. Sapp, Tampa, Fla.
WSB—775, W. R. Clark, Jr., Bridgeport, Conn.
WSL—1475, M. A. Acheson, Houston, Tex.
WSY—900, W. R. Clark, Jr., Bridgeport, Conn.
WWAY—975, M. A. Acheson, Houston, Tex.

Crystal Set

KDKA—1175, M. A. Acheson, Houston, Tex.
KFAF—875, M. A. Acheson, Houston, Tex.
KFFQ—825, M. A. Acheson, Houston, Tex.
KFI—1350, M. A. Acheson, Houston, Tex.
KHL—1350, M. A. Acheson, Houston, Tex.
KPC—1600, M. A. Acheson, Houston, Tex.
KSD—700, M. A. Acheson, Houston, Tex.
KVW—975, M. A. Acheson, Houston, Tex.
KZN—1200, M. A. Acheson, Houston, Tex.
PWX—950, M. A. Acheson, Houston, Tex.
WAAP—575, M. A. Acheson, Houston, Tex.
WDAP—650, M. A. Acheson, Houston, Tex.
WDAP—970, M. A. Acheson, Houston, Tex.
WGL—1625, M. A. Acheson, Houston, Tex.
WGM—700, M. A. Acheson, Houston, Tex.
WGY—325, M. A. Acheson, Houston, Tex.
WGY—1500, M. A. Acheson, Houston, Tex.
WHA—1000, M. A. Acheson, Houston, Tex.
WHB—650, M. A. Acheson, Houston, Tex.
WLAG—1075, M. A. Acheson, Houston, Tex.
WMC—500, M. A. Acheson, Houston, Tex.
WOC—875, M. A. Acheson, Houston, Tex.
WOS—650, M. A. Acheson, Houston, Tex.
WSB—725, M. A. Acheson, Houston, Tex.
WWJ—1125, M. A. Acheson, Houston, Tex.

ERLA DUO-REFLEX SET

Complete parts for Erel Duo-Reflex Circuit, consisting of the following parts: 1 23-plate Vernier Var. Condenser; 1 Variocoupler; 1 Cunningham 301-A Tube; 1 Erel Duo-Reflex R. F. Trans.; 1 Marie Audio Freq. Trans.; 1 Gold Grain Detector; 1 Howard 25-ohm Rheostat; 1 Socket; 2 3-inch Dials; .001 and .002 Mica Condensers; 12 Switch Points; 4 Stors; 2 Switch Levers; 8 Binding Posts; 7x12 Radion Blue Print; 7x12 Mahogany Cabinet; Buss Wire; Erel Duo-Reflex, drawn to scale, covering every detail of construction. Regular price \$42.25. **\$27.95**

List Price	Our Price
\$ 9.00—Cunningham 301-A	\$ 5.70
9.00—UV-201-A	5.75
6.50—UV-199	5.85
75.00—RADIOLA SENIOR (Phones and Tube)	\$52.50
68.00—RADIOLA SENIOR Amplifier (Tubes)	\$52.50
70.00—TUSKA TYPE 222 (3 Circuits)	\$55.00
97.50—RADIOLA II (Batteries and Phones)	\$81.95
9.00—Kelloge Variocoupler	7.50
8.00—Kelloge Variometer	7.10
1.50—LOADING COIL (Add 200 meters)	\$0.65
"B" Batteries (Never over 5 days' old.)	
1.75—Eveready 22½ Volt No. 76395
3.00—Eveready 22½ Volt No. 766	2.10
5.50—Eveready 45 Volt No. 767	3.95

Everything guaranteed as firsts. Send for Special Price List. We pay postage.

254 W. Stiegel St. RADIO SUPPLY STORES Mannheim, Pa.

Freshman Fix - 0

A Fixed Resistance Leak Combination—4 in One

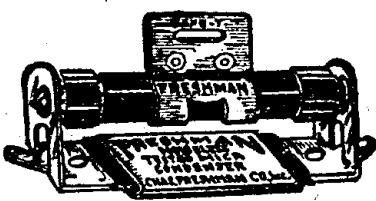

Freshman Condenser Leak Mounting
Freshman Fixed Leak SAFE-T HANDLE **65c** Complete

Furnished in Any Value of Resistance from ½ to 10 Megohms. Separate Condenser and Mountings, 40c. Separate Leaks with Safe-T Handle, 30c.

At your dealers, otherwise send purchase price and you will be supplied postpaid.

Chas. Freshman Co. Inc. Radio Condenser Products 106 SEVENTH AVE., NEW YORK

Portable Set Contest Rules

The rules to follow in the contest are but few and easily followed. They are:

1. Amateurs who are able to beat the records given, or who can claim with good evidence, distance receiving records of 300 statute miles or more for Radio-Phone broadcasting stations found in the "Broadcasting Station Directory," page 8, of three consecutive issues, may send in such records. These must be made with a portable set and when records are submitted, the contest class it falls in must be told. These three contest classes are: Single tube receivers, sets using a loop aerial and having three tubes or less, and crystal sets.

2. Distances must be measured AIR-LINE and expressed in statute miles. Disregard of this rule may cause amateurs to be declared ineligible.

3. Call signals of station heard, its location and the mileage, as defined in Rule 2, must be given in reporting record. Otherwise record will not be considered.

4. Distances are verified by the contest department of this publication, using a Geo. F. Cram Co. standard Radio map of the United States. Owing to much variance in maps, the distances are only given to the nearest 25 miles and are claimed accurate only within 50 miles.

5. There are no prizes awarded. The only compensation record holders receive is the distinction of recognition through the columns of RADIO DIGEST.

WSY "Official" Broadcasts Increase Farm Stations

BIRMINGHAM, ALA.—WSY of the Alabama Power company is now broadcasting all government matter along with their regular program. Weather reports, department of agriculture matter, lectures and other government information are broadcast. The station is also broadcasting market reports. Many farmers all over Alabama, Mississippi, Tennessee and Georgia are putting in receiving stations since this service has been started by WSY, saying the service is of great value to them and is worth many times the cost of a receiving station.

Conferences are to be held at Paris, London, Berlin and other centers in Europe for the development of an international radio service.

45 PER CENT OFF

YOUR MONEY BACK AND \$100.00 REWARD IF THESE ARE NOT GENUINE DEFOREST VACUUM TUBE RECEIVING SETS

LIST	
Deforest Receiver	\$36.00
W.D.-12 Tube	6.50
Signal Corps Phones	12.00
B Battery	3.00
A Battery50
Antenna Equipment	2.50
Book, "The Radio Telephone"50
Honeycomb Coil	1.50

Our Price Complete..... **\$34.38**

SEND MONEY ORDER **C. W. Thompson Company** MATTOON, ILLINOIS

Re-Organized!

HORNE MANUFACTURING CO. now known as the **HORNE ELECTRIC & MFG. CO.**

will continue the manufacture and sale of the well known Horne Radio Products, consisting of 50 Radio Devices, and will conduct an energetic summer sales campaign on the following new devices:

"PORTO-SET"	\$43.00
(Trade Mark)	
Portable set in leather carrying case for vacationists, consisting of one stage radio and one stage audio on single tube, energized by flashlight battery.	
"VARIO-LEAK"	\$1.50
(Trade Mark)	
A substantial Variable Grid Resistance, Panel, Mounted, operated like a Rheostat.	
"Vernier Condenser"	\$0.90
Two leaf type for either Table or Panel Mounting. No moving contacts.	

Write for latest catalog

Write direct if your dealer can't supply you. **Horne Electric & Manufacturing Co.** Main Office and Works Mercer & Colgate Streets, Jersey City, N. J. New England Factory and Warehouse 54 Old Colony Avenue, Boston

BROADCASTERS TO OBTAIN OWN MUSIC

Decision Is Outcome of Convention Held Recently in Chicago

CHICAGO.—The Radio public is to be furnished with an endless stream of high grade musical selections, it was announced by Paul B. Klugh, executive chairman of the National Association of Broadcasters, at a meeting of the executive committee held recently at Chicago.

The National Association of Broadcasters, which was formed as a result of the American Society of Composers, Authors and Publishers' demands for a license fee for the privilege of using selections copyrighted by their organization, has adopted a definite policy of refusing to use any of the society's selections. This decision is based not on the grounds that to so use them would be public performance for profit, but that in using them, the broadcaster would be rendering a service in popularizing the pieces that should be paid for by the music publisher who draws his profits from mechanical rights and sales of sheet music.

The broadcaster association, on the other hand, underwritten by some of the most influential broadcasters in the country, is ready to furnish music written by well-known composers so that the Radiophan will not miss the music of the American Society.

The audion bulb is about 30 times as strong as the crystal.



RUSONITE CRYSTAL RECTIFIER MULTIPPOINT (Patent Pending)

A Synthetic CRYSTAL DETECTOR sensitive over its entire surface. Eliminates all detector troubles. Extraordinary clearness and volume. Endorsed by Radio experts and press for both REFLEX CIRCUITS and CRYSTAL SETS. Sold in Sealed Packages only.

Price mounted, Sensitivity guaranteed..... **50c**

RUSONITE CATWHISKER

14 Karat Gold Multiple Contact Super Sensitive..... **25c**

Order from your dealer or direct from us, **RUSONITE PRODUCTS** 19 Park Row, New York

RADIO VIA PARCEL POST AT N. Y. PRICES

Standard Parts Only, in Original Packing NO SALVAGED GOODS SOLD Where "Money Back Policy Prevails"

PHONES	For Parcel Post	Ina. Add
Dietzen 3,000 Ohm	\$3.75	\$0.12
Brown Single (4,000 Ohm Pr.)	4.95	.09
Royal 2,200 Ohm	3.75	.12
Holtzer Cabot	7.95	.14
COUPLERS		
Atwater Kent	6.80	.14
All Wave (Genuine Capitol)	6.95	.18
VARIOMETERS		
Dayton	4.85	.12
VARIABLE CONDENSERS		
U. S. Tool 46-Plate Vernier	4.45	.24
U. S. Tool 24-Plate Vernier	4.10	.20
8 Plate Vernier95	.08
23 Plate Vernier	2.95	.14
43 Plate Vernier	3.45	.18
TRANSFORMERS (Audio Frequency)		
Sampson	4.95	.15
All American 3 to 1	4.00	.14
All American 5 to 1	4.10	.14
All American 10 to 1	4.30	.14
Acme	3.45	.14
TRANSFORMERS (Radio Frequency)		
Acme	3.45	.14
Cotoco	2.45	.12
Owl95	.10
MISCELLANEOUS		
Switch Lever, Radio Type19	.06
Ammeter Testing B Battery49	.08
Two Slide Tuning Coil	1.25	.12
Hydrometers49	.08
Electric Soldering Iron	2.50	.15
Double Phonograph Attachment	1.15	.08
SETS		
Westinghouse, Jr.	6.95	.40
Aerax Crystal Set	7.95	.45
Victor Single Tube, completely assembled	12.50	.45
Victor Two Stage	12.50	.45
RHEOSTATS		
Kloster Vernier	1.25	.14
Bradycostat	1.49	.10
Union Radio65	.08
SOCKETS		
Bell V. T. & W. D. II89	.10
V. T. Bakelite50	.10
LOUD SPEAKERS		
King Amplitone Horn	4.95	.28
Heller	9.85	.30
Phonaflex	15.00	.50
TUBES		
Welch Peanut Tube	2.00	.10
Sterling 1½ V.	3.95	.15
Margo 1½ V. (2 Elements)	1.00	.15
Do Forest D. V. 6 A.	5.75	.15
CABINETS (In White)		
7x10	1.45	.20
7x12	1.65	.25
7x14	1.85	.30
7x18	2.15	.45
7x21	2.45	.45
7x24	2.95	.50
LIGHTNING ARRESTERS		
Argus, Outdoor or Indoor95	.12
Brach, Outdoor	1.95	.14
DIALS		
2-inch (Bakelite)25	.08
3-inch (Bakelite)35	.08



Modell's ESTABLISHED 1894 191 Fulton St., Dept. F-19, New York City 9 New York Stores America's Greatest Radio Mail Order House

The Week's Advance Broadcast Programs

Tuesday, June 26

CFCA (Eastern, Daylight Saving, 400), 8:00-9:00 P. M., Concert, "Egmont," Star Orchestra; "Pale Moon," Kate Jackson, contralto; "Out of the Dusk," V. Woods, soprano; "Pulcinella," orchestra; "The Swallows," Kate Jackson, contralto; selection from "Katinka," orchestra; "I Love You More," W. Woods; "Serenade," orchestra; "Bonnie Sweet Besiege," Kate Jackson; "Mignonette," orchestra.

KHJ (Pacific, 400), 12:30-1:15 P. M., Mary Christine Albin, pianist; 2:30-3:30 P. M., Matinee performance; 6:45-7:30 P. M., Children's Hour; Harry Beardsley, baritone; Bedtime stories, Uncle John; 8:00-10:00 P. M., Concert, Flounroy's Californians Orchestra.

KYW (Central, Daylight Saving, 345), 8:00-8:58 P. M., Dance music, Cope Harvey's Orchestra; 8:58 P. M., Musical program; Lucille Westerfield, soprano; Harriet Weeber, pianist; Mrs. D. B. Hayden, reader; Russell Longmire, baritone.

WBAP (Central, 476), 9:30-10:30 P. M., Concert, Fred Cahoon's Texas Hotel Orchestra.

WDAR (Eastern, Daylight Saving, 395), 12:00-12:54 P. M., Organ recital, Stanley Theatre; 2:00-3:00 P. M., Song recital; 4:30-6:00 P. M., Musical program; Talk, "Affairs of the Heart," Betsy Logan; 7:30-8:00 P. M., Dream Daddy.

WFAA (Central, 476), 12:30-1:00 P. M., Address, DeWitt McMurray; 8:30-9:30 P. M., Concert, Netto Quartet of Male Singers; 11:00-12:00 P. M., Musical recital, arranged by Sanger Bros.

WFI (Eastern, Daylight Saving, 395), 1:00 P. M., Dinner music, Meyer Davis Bellevue-Stratford Concert Orchestra; 3:00 P. M., Song recital; 6:20 P. M., Baseball scores; 6:30 P. M., Dinner music, Meyer Davis Bellevue-Stratford Concert Orchestra; 7:00 P. M., Safety talk, Stanley Cowman; 8:00 P. M., Boy Scout report; 8:30 P. M., Musical selections; 10:30 P. M., Meyer Davis Bellevue-Stratford Dance Orchestra.

WGI (Eastern, Daylight Saving, 360), 8:30 P. M., Business report, Roger W. Babson; Amrad Players with Amrad Orchestra.

WGY (Eastern, 380), 1:00 P. M., Talk, "Indian Folk Lore and Legends," Mrs. Katherine V. Steers; 7:35 P. M., Talk, "Establishing the Pheasant," Justin T. Mahoney, State Conservation Commissioner; 7:45 P. M., Musical program, courtesy Albany Music Teachers Assn.; "Mirage," instrumental ensemble; "Scherzo in B Flat Minor," Mary Hoeflich, pianist; "Elsa's Dream," from "Lohengrin," Mary Whish, soprano; "Adagio," from "Hondo Allegretto," from "Seventh Concerto," David Harris, violinist; "The Wood Pigeon," Katherine Crumney, singer; "Pony Race," Ruth Feinburg, pianist; "Will Ye Remember," I Must Down to the Sea," Chester Gilligan, "The Nightingale," Marion Conkline, pianist; "Scene de Ballet," Alice Cooper, violinist; "Valse Erotica," Fredericka Phelps, saxophonist; "Sonata Pathetique," First Movement, Genevieve Peter, pianist; "The Springtime of the Year," "Irish Folk Song," Marjorie MacFarland, singer; "Hungarian Rhapsody," No. 12, Stanley Hummel, pianist; "Air for G String," Violin choir.

WHAS (Central, 400), 4:00-5:00 P. M., Concert, Mary Anderson Theatre Orchestra; Olio Jones, conductor; 7:30-9:00 P. M., Concert, Franklin's Dance Orchestra; Reading, "An Interesting Historical Episode."

WIP (Eastern, Daylight Saving, 509), 3:00-4:30 P. M., Musical program; 6:00-6:45 P. M., Dinner music; 7:00-7:30 P. M., Bedtime stories, Uncle Wip; 8:30 P. M., Short talk; 9:00 P. M., Song recital; 10:10 P. M., Dance music, Charlie Kerr's Cafe LaFleur Orchestra.

WJAX (Eastern, 390), 7:30 P. M., Concert, Cleveland News.

WLW (Central, Daylight Saving, 309), 10:00 P. M., Concert, Ise Huebner and pupils; Playlet, "Never-theless," Amber Wharton, Ralph Haberton and Alvin R. Plough.

WMAQ (Central, Daylight Saving, 447), 7:00-8:00 P. M., Babson report; Miriam Aaron, soprano; 9:15-10:00 P. M., Musical program arranged by Mrs. Elizabeth Oik Boelke, violoncellist.

WMC (Central, 400), 8:30 P. M., Concert, Memphis Male Quartet.

WOC (Central, 484), 3:30 P. M., Educational talk, A. G. Hinrichs; 5:45 P. M., Chimes concert.

WOO (Eastern, Daylight Saving, 509), 11:00 A. M., Organ recital, Mary E. Vogt; 12:00-12:55 P. M., Dinner music, Tea Room Orchestra; 4:45-5:00 P. M., Organ recital, Mary E. Vogt.

WVJ (Eastern, 517), 7:30 P. M., Concert, Schemann's Band; 8:30 P. M., News Orchestra; Mrs. Harriett E. Wray, soprano; D. M. Vint, tenor; Robert & Paul Smith, baritone.

Wednesday, June 27

CFCA (Eastern, Daylight Saving, 400), 8:00-9:00 P. M., Concert, "Ruy Blas," Star Orchestra; "Anethama," Alex. Eldor, baritone; "Viennese Melody," Mannie Roth, violinist; "L'Extase," orchestra; "How Can I Comfort Ye," Alex. Eldor; "Serenade," orchestra; "Chanson Arabe," Mannie Roth; "Dance of the Hours," orchestra; "Fill a Glass with Golden Wine," Alex. Eldor; "Turkish March," orchestra.

KHJ (Pacific, 400), 12:30-1:15 P. M., Concert, Hawaiian Orchestra from the S.S. "Calavall"; 2:30-3:30 P. M., Musical matinee, Hawaiian Orchestra; Lecture, Rae N. Victor; 6:45-7:30 P. M., Children's Hour; music and bedtime story, Uncle John; 8:00-10:00 P. M., Program arranged by Downey Women's Club.

KSD (Central, 546), 8:00 P. M., Recital; Mrs. Hector Pasamezolu, soprano; Olga Hambeuechen, contralto; Harvey W. Ramsay, tenor; Raymond Koch, baritone; Paul Friess, pianist; Address, Mayor Henry Kiel of St. Louis, F. W. A. Vesper, president St. Louis Chamber of Commerce.

KYW (Central, Daylight Saving, 345), 8:00-8:58 P. M., Dance music, Cope Harvey's Orchestra; 8:58 P. M., Musical program, Florence Kramp; soprano; Mary Welch, contralto; Mark Lora, baritone; Howard Neumiller, accompanist; Charles Blum, harmonica.

WBAP (Central, 476), 9:30-10:30 P. M., Concert, Texas Melody Boys' Dance Orchestra.

WDAR (Eastern, Daylight Saving, 395), 12:00-12:54 P. M., Organ recital, Stanley Theatre; 2:00-3:00 P. M., Features from Stanley Theatre; 4:30-6:00 P. M., Song recital; 7:30-8:00 P. M., Dream Daddy; 8:30 P. M., Musical program, Howard Lanin's Arcadia Cafe Dance Orchestra.

Crystal Fans Wake Up

"The Vacuum Tube's Only Rival" Lasts Indefinitely

50c **CRYSTAL** 50c

Approved by Mail, Tribune, Radio World

Make your set sound like a brass band

RADIO CORPORATION OF AMERICA OPERATIVES use the L. D. R. Crystal as detector in conjunction with one or more stages of amplification. Satisfaction guaranteed or money refunded.

JACK BINNS OF S. O. S. FAME

Radio Ed. Tribune Radio Laboratory, recently awarded a certificate of excellence to the L. D. R. Super-Crystal, stating—"The L. D. R. Super-Crystal is exceptionally sensitive and covered with many amplification spots. All that can be desired in a real good radio crystal that will last indefinitely."

FREE Crystal Amplification Hook-ups.

FREE the 1000 Mile One Tube Reflex Hook-up.

JAYNXON LABORATORY
57 Dey St. New York City

WFAA (Central, 476), 12:30-1:00 P. M., Musical program by Melba Theatre talent.

WFI (Eastern, Daylight Saving, 395), 1:00 P. M., Dinner music, Meyer Davis Bellevue-Stratford Concert Orchestra; 3:00 P. M., Concert; 3:45 P. M., Song recital; 6:20 P. M., Baseball scores; 6:30 P. M., Dinner music, Meyer Davis Bellevue-Stratford Concert Orchestra; 7:00-7:30 P. M., Bedtime stories, Cousin Sue.

WGI (Eastern, Daylight Saving, 360), 6:45 P. M., Girls' Hour, Eunice L. Randall; 8:30 P. M., Talk.

Thursday, June 28

CFCA (Eastern, Daylight Saving, 400), 8:00-9:00 P. M., Concert, "Spanish Dances," Star Orchestra; "Cavalleria Rusticana," Lyona Hunt, soprano; "Berceuse," Jacques Stern, cellist; "Mignon," orchestra; "Elli, Elli," Lyona Hunt, soprano; "Espagnole," orchestra; "Ave Maria," Jacques Stern, cellist; "Il Trovatore," orchestra; "As I Went a-Roaming," Lyona Hunt; "Praeludium," orchestra.

KHJ (Pacific, 400), 2:30-3:30 P. M., Matinee musical, Naomi Sweeney Brown, whistler; 6:45-7:30 P. M., Children's Hour; 8:00-10:00 P. M., "A Night in the Trenches," The California Hut.

KYW (Central, Daylight Saving, 345), 8:00-8:58 P. M., Musical program, courtesy of Inland Tellec. Co.; Dance music, Cope Harvey's Orchestra; Wendell W. Hall, KYW's Music Maker; 9:05-9:25 P. M., "Twenty Minutes of Good Reading," Rev. C. J. Perlin, S. J. Dept. of English, Loyola University.

WBAP (Central, 476), 9:30-10:30 P. M., Concert, Fort Worth Police Band.

WDAR (Eastern, Daylight Saving, 395), 12:00-12:54 P. M., Organ recital, Stanley Theatre; 2:00-3:00 P. M., Musical program; Talk, "Affairs of the Heart," Betsy Logan; 4:30-6:00 P. M., Song recital and short talks; 7:30-8:00 P. M., Dream Daddy.

WFAA (Central, 476), 12:30-1:00 P. M., Address, "How General Shoups-Lays De Made?" O. O. Touchstone, president Dallas Bar Assn.; 8:30-9:30 P. M., Musical program, Wednesday Morning Choral Club; 11:00-12:00 P. M., Recital, arranged by D. I. Whittle Music Co.

WFI (Eastern, Daylight Saving, 395), 1:00 P. M., Dinner music, Meyer Davis Bellevue-Stratford Concert Orchestra; 3:00 P. M., Song recital; 3:45 P. M., Concert; 6:20 P. M., Baseball scores; 7:00 P. M., Short talks; 8:00 P. M., Musical program.

WGI (Eastern, Daylight Saving, 360), 8:30 P. M., Songs, Dean Winslow Hanson, tenor; Talk, "Rentals and Housing Conditions," I. E. Dierdorf; Concert, Amrad Piano-forte Club.

WGY (Eastern, 380), 1:00 P. M., Talk, "Mental Hygiene—What New York State is Doing for the Mentally Defective," Eleanor A. Gray, N. Y. State Dept. of Education; 7:45 P. M., Musical program; "March of the Gladiators," Cyprus Temple Shrine Band of Albany, N. Y.; "W. Elmore Slack, director; "Rival Overture," band; "My Laddie," Alice Brown, soprano; "Forest Whispers," "Ballet Music," band; "O, Dry Those Tears," Alice Brown; "Sounds from the South," "The Bandman's Delight," band; "The

What Time Is It?

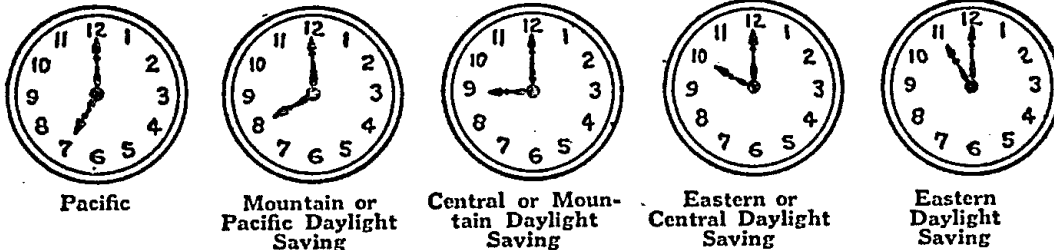

THE above clock dials are shown to clear up the misunderstanding which the various time bands and the Daylight Saving plan are creating. Although each dial registers time one hour ahead or behind of its neighbor, the exact period indicated on each dial is the same as that on every other. This chart will aid in the use of the advance programs and the schedules in the Radiophone Broadcasting Station Directory, both of which give the hours stated in the particular kind of time in use at each station. Only features are listed in the advance programs below. Much additional data and such parts of station schedules as are regular features week in and week out, will be found in the station directory which appears serially continuously on page eight.

"Science Up to Date," Scientific American Magazine; Concert, Mabel Mulrey, soprano; Irene Mulrey, pianist; Mrs. Maud Dunn, reader.

WHAS (Central, 400), 4:00-5:00 P. M., Concert, Mary Anderson Theatre Orchestra; 7:30-9:00 P. M., Musical program, Richard Wymond, violinist; Ruth Sharp, pianist; Bryan Holloway, baritone; Billy Hinkle; guitar; Mandolin and guitar duo, Jean Kohlhepp, Billy Hinkle; Reading, "An Interesting Historical Episode."

WIP (Eastern, Daylight Saving, 509), 1:00-2:00 P. M., Organ recital, Karl Bonaytz; 3:00-4:30 P. M., Musical program; 6:00-6:45 P. M., Dinner dance music; 7:00-7:30 P. M., Bedtime stories, Uncle Wip.

WLW (Central, Daylight Saving, 309), 8:00 P. M., Aichele Novelty Orchestra; Swimming Lesson No. 4, Stanley Brauminger, Sam Ward, comedian; Al Zef, entertainer; Talk, E. C. O'Donnell; Songs, Lavergne Sims; Aichele Orchestra; "Come, Beloved," "Pleurez, Pleurez Mes Yeux," Leah Fred; Zither duets, Ruth Hoho, Chas. Hoho; "A Dream," "O Sole Mio," "Last Rose of Summer," Leah Fred; Zither duet, Ruth Hoho, Chas. Hoho; "Beloved, It Is Morn," "Bitterness of Love," "Carmena," Leah Fred; Zither duets, Ruth Hoho, Chas. Hoho; Aichele Orchestra.

WMAQ (Central, Daylight Saving, 447), 7:00-8:00 P. M., Stories, Georgene Faulkner; Talk on Chemistry, J. A. Hynes, chief chemist, U. S. Customs Laboratory; 9:15-10:00 P. M., Musical program, Elizabeth Lay Newman, soprano; Alfred Newman, baritone; Thos. Pither, tenor.

WOC (Central, 484), 3:30 P. M., Educational talk, D. K. Kirk; 8:00 P. M., Recital, Erwin Swindell, organist; Mrs. John Rolling, soprano; 10:00 P. M., Gladys Muerling, Louise Bolin, Grace Lindberg, Clara Storin, Adeline Howkinson.

WOO (Eastern, Daylight Saving, 509), 11:00 A. M., Organ recital, Mary E. Vogt; 12:00-12:55 P. M., Dinner music, Tea Room Orchestra; 4:45 P. M., Organ recital, Mary E. Vogt; 7:30 P. M., Baseball scores and sporting results; 7:45 P. M., Dinner music, Adolph Hotel Orchestra; 8:30 P. M., Song recital; 9:00 P. M., Organ recital, Mary E. Vogt.

WVJ (Eastern, 517), 7:30 P. M., Concert, News Orchestra; Mrs. Grace George, soprano; Mrs. C. H. Davis, pianist; Greta Maedel, soprano.

SPECIAL

Direct From Manufacturer to Consumer

Save the Difference

LOUD SPEAKER

GENUINE WOOD FIBRE HORN

10-Inch Bell with Standard Attachment; Complete Height 24 inches. Colors, Black, Mahogany and Olive Green.

Price—\$5.00

Delivered to any part of the United States and Canada.

Send Money Order

EMIL DECLYNE

15 Park Row Room 2525
NEW YORK CITY

Dept. R. D. Barclay 6298

AEROVOX

No. 1010X

30 Ohm Rheostat

Excellent results assured with use on New Type Tubes

UV199A UV201A

Using small filament current

6 Ohm\$0.75

20 Ohm1.00

30 Ohm1.10

At your dealers. Otherwise sent postpaid on receipt of purchase price.

Write for catalog illustrating and describing our entire line of quality apparatus.

Territory Open for Jobbers

AEROVOX WIRELESS CORP.

208 West 17th Street NEW YORK

BOOK OF HOOKUPS

For One Dollar

Reinartz Flewelling Reflex

many others, simple and elaborate, fully diagrammed and explained. Used continuously by thousands of Radio fans, both amateurs and professionals. The greatest book ever published for experimenting. Keep this valuable little book before you at all times. Send your check or money-order for one dollar and the book will be mailed to you. Forty-seven hook-ups, all different. Send your order today. The edition is limited.

Book of Hook-ups, \$1.00

E L S RADIO COMPANY

Randolph Building
CHICAGO, ILL.

Special Offer to Dealers

Little Damsel," Alice Brown; "Lustspiel," "Coronation March," band.

WHAS (Central, 400), 4:00-5:00 P. M., Concert, Mary Anderson Theatre Orchestra; 7:30-9:00 P. M., Concert, Warren Memorial Church Choir Quartet; Mary Anderson Theatre Orchestra; Sunday School Lesson, Dr. E. D. Patterson; Talk, Miss M. L. Speed.

WIP (Eastern, Daylight Saving, 509), 3:00-4:30 P. M., Recital; 6:00-6:45 P. M., Dinner music; 7:00-7:30 P. M., Bedtime stories, Uncle Wip; 8:00 P. M., Musical program.

WJAX (Eastern, 390), 8:00 P. M., Concert, Hotel Cleveland Orchestra.

WLW (Central, Daylight Saving, 309), 8:00 P. M., Concert, Budd Rudd's Collegian Dance Orchestra; "In the Days of Knighthood," "Gypsy Serenade," Carlo Mastropalo, violinist; "Norwegian Dance," "Valse Caprice," Rosina Arrico, pianist; "Lucian Polka," Corea Swartz, cornetist; "Hollin duet, Carlo Mastropalo, Erwin Breustle; Selections by orchestra; "Cavatina," "Calm as the Night," Erwin Breustle, violinist; "Sabbastian Love Song," Rosina Arrico; "Commodore," Corea Swartz, cornetist; Violin duet, Carlo Mastropalo, Erwin Breustle; orchestra.

WMAQ (Central, Daylight Saving, 447), 7:00-8:00 P. M., Talk on Auto Trails, Rockwell Stephens; Talk to Boy Scouts, Gilbert Butler; Talk, "Our Northern Neighbors," Capt. J. Milton Stato; 9:15-10:00 P. M., Mixed quartet.

WMC (Central, 400), 8:30 P. M., Concert, Hotel Chelsea Philharmonic Orchestra.

WOC (Central, 484), 3:30 P. M., Educational talk, Karl G. Stephan; 5:45 P. M., Chimes concert.

WOO (Eastern, Daylight Saving, 509), 11:00 A. M., Organ recital, Mary E. Vogt; 12:00-12:55 P. M., Dinner music, Tea Room Orchestra; 4:45-5:00 P. M., Organ recital, Mary E. Vogt; 7:30 P. M., Baseball scores.

WVJ (Eastern, 517), 7:30 P. M., Concert, Schemann's Band; 8:30 P. M., News Orchestra; Miriam Bloo, pianist; Frank Hawkes, pianist; Anne Curran, soprano; Edgar Hagel, saxophonist; 10:00 P. M., Dance program, Peacock Orchestra.

Friday, June 29

CFCA (Eastern, Daylight Saving, 400), 8:00-9:00 P. M., Concert, "Lohengrin," Star Orchestra; Mary Bothwell, contralto; "Canzonetta," Harry Adaskin, violinist; "La Carline," orchestra; Mary Bothwell, contralto; "Sleeping Beauty Waltz," orchestra; "Songs My Mother Taught Me," Harry Adaskin; Mary Bothwell, Selection from "The Country Girl," orchestra.

KHJ (Pacific, 400), 2:30-3:30 P. M., Matinee musical; 6:45-7:30 P. M., Children's Hour; 8:00-10:00 P. M., Program, arranged by Lillian Martin.

KSD (Central, 546), 8:00 P. M., Opera, "Die Fledermaus" (The Bat), Municipal Open Air Theatre.

KYW (Central, Daylight Saving, 345), 8:00-8:58 P. M., Musical program, courtesy of Lyon & Healy Concert Dept.; Cope Harvey's Orchestra; 9:05-9:25 P. M., Book reviews, Lawellon Jones.

WBAP (Central, 476), 9:30-10:30 P. M., Concert, Original Johannes Jolly Jazz.

WDAR (Eastern, Daylight Saving, 395), 12:00-12:54 P. M., Organ recital, Stanley Theatre; 2:00-3:00 P. M., Song recital; 4:30-6:00 P. M., musical program; Talk, "Affairs of the Heart," Betsy Logan; 7:30-8:00 P. M., Dream Daddy; 8:00 P. M., Short talks, musical selections, dance music, Howard Lanin's Arcadia Cafe Dance Orchestra.

WFAA (Central, 476), 12:30-1:00 P. M., Address, (Continued on page 9.)

How to Make a Flewelling Receiver

BLUE PRINTS

for the construction of a Flewelling Receiving Unit and two step amplifier.

ALL DETAILS FOR ASSEMBLY

Description of apparatus and accessories and details of tuning.

'CABINET DIMENSIONS PANEL LAYOUTS LIST OF PARTS

Send only money orders—no checks or stamps. Coins at your own risk.

Book Department

Radio Digest

123 W. Madison St., Chicago, Ill.

only 50c

Radiophone Broadcasting Stations

Corrected Every Week—Part II

(NOTE.—The second part of the schedule list appears below. The first appeared last week and the third part will appear next week.)

KUY, El Monte, Calif. 360 meters. 500 ml. Coast Radio Co. Wed. 4-4:30 pm. Sat. 3-4 pm. Pacific.

KWG, Stockton, Calif. 1,500 ml. Portable Wireless Telephone Co. Daily ex Sun, 4-5 pm, news, concert, markets. Tues and Fri, 8-9 pm, concert. Sun, 2-3 pm, concert. Pacific.

KWH, Los Angeles, Calif. 360 meters. 250 ml. Examiner. Daily ex Sun, 1:30-1:40 pm, 5:30-6, 6-6:15, 8:20-9, reports, entertainment. Sun, 8:30-9 pm, church service. Pacific.

KXD, Modesto, Calif. 360 meters. 100 ml. Modesto Herald Pub. Co. Daily ex Sun, Mon, 6:30-7 pm. Mon, 7-9 pm. Sun 1-2 pm. Pacific.

KYQ, Honolulu, Hawaii. 360 meters. Electric Shop. No definite schedule.

KYV, Chicago, Ill. 345 meters. 2,000 ml. Westinghouse Elec. & Mfg. Co. Daily ex Sun, 9:30 am, 10:30, 11, markets; 11:05, weather; 11:30, news; 11:35, table talk; 12, 12:30, 1, 2, 2:15, 2:30, markets; 3, 3:30, 4, news; 4:15, markets; 4:30, 5, news; 6:30, markets; 6:50 bedtime story; 8, concert, 9, special. Sun, 11 am, 3:30 pm, 7, church services. Central, Daylight Saving.

KZM, Oakland, Calif. 360 meters. 200 ml. Western Radio Institute (Hotel Oakland). Daily ex Sun, 6:45-7 pm, news. Pacific.

KZN, Salt Lake City, Utah. 360 meters. 1,000 ml. Desert News. Slogan, "The Center of Scenic America." Daily ex Sun, 8:30-9 pm, music, news, bedtime stories, etc. Mountain.

KZV, Wenatchee, Wash. 360 meters. 200 ml. Wenatchee Battery & Motor Co. Daily ex Sun, 3:30-4:15 pm, weather. Mon, Wed, Fri, 1st to 15th each month, 8:45-9:30 pm; 15th to last each month, 8:45-9:45 pm, weather. Sun, 1st to 15th each month, 7:30-9 pm; 15th to last each month, 11 am-12:30 pm, church services. Eastern.

NAA, Radio, Va. 435 meters. 2,000 ml. U. S. Navy Dept. Daily ex Sun, 9:45-10:40 am, 12:25-12:40 pm, 1:45-2:20, markets, weather; 2:45-3 (Tues. only). Dept. Interior: 3:25-4:40, 5:05-5:20, markets, weather 10:05-10:20, weather. Mon, 6:45-8:20 pm, Dept. programs. Tues, 7:05-8:20 pm, Dept. programs, Wed, 7:25-7:40 pm, Dept. programs; 8:05-9:40, Marine Band. Thurs, 6:45-8:40 pm, Dept. programs. Fri, 8:05-8:40 pm, band concert. Eastern.

OA, Ottawa, Ont., Can. Dept. of Marine & Fisheries.

PWX, Havana, Cuba. 400 meters. 1,500 ml. International Tel. & Teleg. Corp. Wed, Sat, 9-11:30 pm, music. Eastern.

WAAB, New Orleans, La. 268 meters. Valdemar Jensen.

WAAC, New Orleans, La. 360 meters. Tulane Univ. Mechanics Inst. No regular schedule.

WAAD, Cincinnati, O. 360 meters. 200 ml. Ohio Mechanics Inst. No regular schedule. Central, Daylight Saving.

WAAF, Chicago, Ill. 286 meters. 300 ml. Chicago Daily Druggist. Daily ex Sat and Sun, 8:40 am, 10:30, 10:45, 12:30 pm, 12:45, 3, 4:30, live stock and weather reports. Central, Daylight Saving.

WAAG, St. Paul, Minn. 360 meters. 500 ml. Commonwealth Elec. Co. Slogan, "From the Land of Ten Thousand Lakes." Temporarily discontinued.

WAAL, Milwaukee, Wis. 280 meters. 300 ml. Gimbel Bros. Daily ex Sun, 10 am, 12:10, 12:10 pm, 1:25, 3, 4:30, 5, 7:30 pm, Central.

WAAM, Newark, N. J. 263 meters. 300 ml. I. R. Nelson Co. Daily ex Sun, 11 am-2 pm, 6-10:30 pm, music. Eastern.

WAAN, Columbia, Mo. 250 meters. Univ. of Mo.

WAAP, Wichita, Kan. 360 meters. 500 ml. United Electric Co. Daily ex Sun, 12-12:30 pm, educational program; 10:30 pm, weather. Tues, Fri, 8 pm, entertainment. Central.

WAAW, Omaha, Neb. 278 meters. 500 Omaha Grain Exchange. Daily ex Sun, 8:45 am, 9:45, 10:45, 11:45, 12:15 pm, 8, market reports; 8:15-9 pm, music. Central.

WAAY, Youngstown, O. 360 meters. 500 ml. Yahrling-Hayner Music Co. Tues, Thurs, Sat, 8-9 pm, music, reports. Eastern.

WAAZ, Emporia, Kans. 360 meters. 250 ml. Hollister-Miller Motor Co. Tues, Thurs, 7-8 pm, entertainment. Temporarily discontinued. Central.

WABA, Lake Forest, Ill. 266 meters. Lake Forest College.

WABB, Harrisburg, Pa. 266 meters. Dr. John B. Lawrence.

WABC, Anderson, Ind. 229 meters. Fulwider-Grimes Battery Co.

WABD, Dayton, O. 263 meters. Parker High School.

WABE, Washington, D. C. 283 meters. Y. M. C. A.

WABF, Marion, Ill. 234 meters. M. Vernon Register-News Co.

WABG, Jacksonville, Fla. 248 meters. 50 ml. Arnold Edwards Piano Co. Daily ex Sun, 3-4 pm, concert. Mon, Thurs, 8-10 pm, concert. Eastern.

WABH, Sandusky, O. 240 meters. Lake Shore Tire Co.

WABI, Bangor, Me. 240 meters. Bangor Ry. & Elec. Co.

WABJ, South Bend, Ind. 240 meters. The Radio Laboratory.

WABK, Worcester, Mass. 252 meters. First Baptist Church.

WABL, Storrs, Conn. 283 meters. Connecticut Agri. College.

WAI, Dayton, O. McCook Field, U. S. Army.

WAJT, Marshall, Mo. 360 meters. Kelly-Vawter Jewelry Co.

WAJU, Yankton, S. D. 360 meters. Yankton College.

WAL, Lafayette, Ind. 360 meters. 100 ml. Purdue Univ. Irregular schedule.

WBA, Minneapolis, Minn. 360 meters. Sterling Elec. Co.

WBAF, Moorestown, N. J. 360 meters. Fred M. Middleton.

WBAH, Minneapolis, Minn. 360 meters. 200 ml. The Dayton Co. Daily ex Sun, 1-1:30 pm, 3-3:30, 5-5:30, 9:30-10. Sat. 11-11:30 am, 8-10 pm, Central.

WBAN, Paterson, N. J. Slogan, "The Silk City of America." 200 ml. Wireless Phone Corporation. Daily ex Sun, 9-11:30 am, 12:30-5:30 pm, Sat morn, only. Sun, 10-12 am, 2-5 pm, 7:30-10:30. Eastern.

WBAO, Decatur, Ill. 360 meters. 100 ml. James Millikin Univ. University activities. No definite schedule. Central.

WBAP, Fort Worth, Tex. 476 meters. 1,500 ml. Fort Worth Star-Telegram Club. "Radio Truth League." Daily ex Sun, 9-9:15 am, 11-11:30, 12-12:15 pm, 1-1:15, 2-2:15, 3-3:30, 8:45-4, markets; 5:30-5:45, 6:30-6:45, 8, sports. Daily ex Sat, Sun, 9:30-10:30 pm, concerts. Sat, 7-7:20 pm, bible lesson. Sun, 11 am-12:15 pm, church; 3:30-4:30, concert. Central.

WBAU, Hamilton, O. 258 meters. Republican Pub. Co. Temporarily discontinued.

WBAV, Columbus, O. 390 meters. 500 ml. The Ernot Hopkins Co. Slogan, "We Broadcast a Variety." Daily ex Sun, 12:30-1 pm. Mon, 7-9 pm, Central.

WBWA, Marietta, O. 246 meters. Marietta College. Temporarily discontinued.

WBAX, Wilkes-Barre, Pa. 360 meters. 200 ml. John H. Stenger, Jr. Three nights of week, not regular.

WBAY, New York, N. Y. 492 meters. 1,500 ml. A. T. & T. Co. Experimental purposes only.

WBBA, Newark, O. 240 meters. Newark Radio Lab.

WBBC, Sterling, Ill. 229 meters. Sterling Radio Equipment Co.

WBBD, Reading, Pa. 224 meters. Barbey Battery Service.

WBL, Anthony, Kans. 261 meters. 200 ml. T & H Radio Co. Mon, Wed, Sat, 8-9 pm, concert, lecture. Sun, 10 am, church service. Central.

WBS, Newark, N. J. 360 meters. 200 ml. D. W. May, Inc. Daily ex Sun 11-12 am, music, reports; 1-2:15 pm, reports; 2:15-2:30 pm, music, reports. Tues, Thurs, Sat, 7:30-9:30 pm, program. Sun, 9-10:30 am, sacred music; 1-3 pm, program. Eastern.

WBT, Charlotte, N. C. 360 meters. 1,200 ml. Southern Radio Corp. Slogan, "Queen City of the South." Daily ex Sun, 11 am, 8 pm, weather, markets. Tues, 8:30 pm, music. Fri, 11 pm, entertainment. Sun, 8 pm, church services. Eastern.

WBU, Chicago, Ill. 286 meters. 100 ml. City of Chicago. Daily ex Sun, 10:15-10:30 am, 11:45-12 pm, 4:15-4:30 pm, police reports. Mon, Wed, Fri, 3:30 pm, 7:30, speeches. Central Daylight Saving.

WBZ, Springfield, Mass. 337 meters. 1,000 ml. Westinghouse Elec. & Mfg. Co. Daily ex Sun, 7:30 pm, children's hour; 7:45, markets, weather, lecture; 8-9, concert. Sun, 8 pm, church service. Eastern.

WCAB, Newburgh, N. Y. 360 meters. Temporarily discontinued.

WCAG, Fort Smith, Ark. 360 meters. John-Fink Jewelry Co. Tests only.

WCAD, Canton, N. Y. 280 meters. 300 ml. St. Lawrence Univ. No regular schedule. Eastern.

WCAE, Pittsburgh, Pa. 326 meters. Kaufman & Baer Co.

WCAF, Rodgers, Mich. 360 meters. Michigan Limestone & Chem. Co.

WCAG, New Orleans, La. 268 meters. 200 ml. Clyde R. Randall. Daily ex Sun, 6:45-7 pm, news, time. Thurs, 8:30-10 pm, concert. Central.

WCAH, Columbus, O. 286 meters. 500 ml. Enteklin Elec. Co. Slogan, "The Heart of Ohio." Daily ex Sun, 11:30-12:30 am, music, news. Tues, 7-9 pm, concert. Sun, 10-12:30, church service. Central Daylight Saving.

WCAI, Univ. of Nebr. 360 meters. 150 ml. Nebr. Wesleyan Univ. Daily, 10:30 am, weather. Tues, 7 pm, bedtime stories. Thurs, 9 pm, music, lectures. Central.

WCAK, Houston, Tex. 360 meters. 100 ml. Alfred P. Daniel. Slogan, "Where Eighteen Railroads Meet the Sea." Daily ex Sun, 7-7:30 pm, music. Wed, 8-9 pm, concert. Sun, 3-4 pm, features. Central.

WCAL, Northfield, Minn. 360 meters. 500 ml. Dept. of Physics, St. Olaf College. Mon, Fri, 7:30 pm, college extension courses. Tues, 8:30 pm, Thurs, 11 pm, Sat, 12 m, music. Tues, Thurs, Sat, 9:40 am, chapel, sports, news. Sun, 8:30 pm, church services. Central.

WCAM, Villanova, Pa. 360 meters. Villanova College.

WCAN, Baltimore, Md. 360 meters. 100 ml. Sanders & Stayman Co. Daily ex Sun, 12-12:20 pm, 5-5:20, Mon, Wed, 8-9 pm. Eastern.

WCAR, San Antonio, Tex. 360 meters. 1,000 ml. Alamo Radio Elec. Co. Mon, Thurs, Sat, 8:30-9:30 pm, concert. Central.

WCAS, Minneapolis, Minn. 360 meters. 500 ml. Wm. H. Dunwoody Industrial Inst. Slogan, "From the Flour City of the World." Mon, 9:30-11 pm, music, lectures. Mon, Wed, Thurs, Fri, 6:30-7 pm, code instruction. Central.

WCAT, Rapid City, S. D. 240 meters. 300 ml. S. D. State School of Mines. Daily ex Sun, 12:30 am, 9 pm, weather, reports. Wed, 7:15 pm, concert. Mountain.

WCAU, Philadelphia, Pa. 286 meters. 500 ml. Durham & Co. Daily 11:45 am. Tues, Fri, 7:30-8 pm, concert. Sun, 10:55 am, church services. Eastern Daylight Saving.

WCAV, Little Rock, Ark. 360 meters. J. C. Dico Elec. Co.

WCAY, Quincy, Ill. 360 meters. 300 ml. Quincy Elec. Supply Co. (Quincy Herald). Daily ex Sun, 5 pm, music. Wed, 7-8:30 pm, concert. Sun, 11 am, church services. 2:45 pm, special programs. Central.

WCAX, Burlington, Vt. 360 meters. Univ. of Vt.

WCAY, Milwaukee, Wis. 261 meters. 500 ml. Kesselman-O'Driscoll Music House. Daily ex Sun, 11 am, reports. Mon, Tues, Thurs, Fri, 8:30-9:30 pm, music. Tues, 10:30-11:30 pm, dance music. Sun, 7:30-9 pm, church services. Central.

WCBA, Carthage, Ill. 360 meters. Carthage College.

WCBB, Allentown, Pa. 280 meters. Chas. W. Haimbach. Wed, Sat, 2-12 pm. Sun, 2-4 pm, 8-10. Eastern.

WCBB, Greenville, O. 240 meters. K. & E. Radio Supply Co.

WCC, Minneapolis, Minn. 360 meters. Findley Elec. Co.

WCK, St. Louis, Mo. 360 meters. 50 ml. Stix, Baer & Fuller. Daily, 12-12:30 pm, 3-4. Mon, Wed, Fri, 6:45-8 pm, concert, lecture. Central.

WCM, Austin, Tex. 360 meters. Univ. of Tex.

WCM, Worcester, Mass. 360 meters. 100 ml. Clark Univ. Daily, 11-15 am, 5-15 pm, weather. Evening program. Irregular. Eastern.

WCX, Detroit, Mich. 517 meters. 1,000 ml. The Detroit Free Press. Slogan, "The Call of the Motor City." Club, "Red Apple Club." Daily ex Sun, 2 pm, news; 2:15, stock reports; 2:50, weather, markets; 4:15, 4:30, 4:50, 6:15, markets, music. Daily ex Sat, 8:30-10 pm, week starting Dec. 11 and alternate weeks thereafter, concert, Tues, 10-12 pm, Club, Sun, 10:30 pm, 7:15 pm, church services. Central.

WDA, Springfield, Ill. 360 meters. Illinois Watch Co. Time and weather, spark only.

WDAD, Lindsborg, Kans. 360 meters. 200 ml. Wm. Louis Harrison. Tues, Thurs, Fri, 9:30 pm, entertainment, weather. Sun, 3:30 pm, vesper services. Central.

WDAE, Tampa, Fla. 360 meters. 500 ml. Tampa Daily Times. Wed, Fri, 8-10 pm, music, lecture. Eastern.

WDAF, Kansas City, Mo. 411 meters. 2,000 ml. Kansas City Star. Club, "Nighthawks." Daily ex Sun, 3:30-4:30 pm, music; 6-7, educational, bedtime story, etc.; 11:45 pm-1 am, Nighthawk Frolic. Mon, Wed, Fri, 8-10 pm, concert. Sun, 4-5 pm, music. Central.

WDAG, Amarillo, Tex. 263 meters. J. Laurance Martin. No regular schedule.

WDAH, El Paso, Tex. 360 meters. Trinity Methodist Church South. Wed, Thurs, Sun, 7:30-8:30 pm. Mountain.

WDAL, Syracuse, N. Y. 246 meters. 200 ml. Hughes Radio Corp. Daily ex Sun, 12 m, reports. Wed, Sat, evening concert. Eastern.

WDAL, College Park, Ga. 360 meters. 2,000 ml. A. & W. P. R. Co. Daily 7:30-8:30 pm, 10:30-11:30 pm, concert. Wed, 10:30-11:30 pm, concert. Central.

WDAL, Hartford, Conn. 261 meters. 150 ml. Hartford Courant. Sat 8 pm, concert. Eastern.

WDAL, Jacksonville, Fla. 360 meters. 250 ml. Florida Times Union. Daily, 11 am, weather; 4-4:30 pm, music; 8-9, entertainment; 9:30, reports, Eastern.

WDAA, Dallas, Tex. 360 meters. 300 ml. Automotive Elec. Co. Daily, 1-1:30 pm, 7:15-8. Central.

WDAP, Chicago, Ill. 390 meters. 2,000 ml. Drake Hotel. Daily ex Sun, every half hour 9:30 am to 1:30 pm, 4:30 pm, reports; 6 pm, news. Tues, Thurs, Sat, 10 pm, concert. Sun, 9 pm, 10, concert. Central Daylight Saving.

WDAR, Philadelphia, Pa. 395 meters. Lit Bros. Club. "Good Morning Glory." Daily ex Sun, 12-12:55 pm, music; 2-3 pm, 4:30-6, music, talks; 7:30-8 pm, Dream Daddy. Mon, Wed, 8-11 pm, entertainment. Fri, 8-10:30 entertainment; 1 am, Club. Eastern Daylight Saving.

WDAS, Worcester, Mass. 360 meters. Samuel A. Waite.

WDAU, New Bedford, Mass. 360 meters. 500 ml. A. H. Smith. Mon, Wed, Fri, 12:15-12:50 pm, industrial reports; 7:45-10 pm, music. Sun, 11 am-12:30 pm, 7-8 pm, church services. Eastern Daylight Saving.

WDAX, Centerville, Iowa. 360 meters. 500 ml. First Nat'l Bank. Daily ex Sun, 11:30 am, reports, news. Mon, Thurs, 7:30-9 pm, concert.

WDAY, Fargo, N. D. 244 meters. 300 ml. Fargo Radio Electric Co. Slogan, "The Biggest Little City in the World." Daily ex Sun, 9:30 am, weather. Tues, Thurs, Sat, 7:30-8:30 pm, concert. Sun, 10:30 am, church services; 4-5 pm, music. Central.

WDB, Lancaster, Pa. 258 meters. Kirk Johnson & Co., Inc.

WDM, Washington, D. C. 360 meters. 50 ml. Church of the Covenant. Sun, 11 am, church service; 8 pm, church service. Eastern.

WDL, New York City, N. Y. 405 meters. Ship Owners Radio Service. Ill. 278 meters. 100 ml. James L. Bush. Daily ex Sun, every half hour, 8:30 am-12:15 pm. Chicago Board of Trade quotations. Central.

WEAA, Flint, Mich. 360 meters. 200 ml. Fallain & Lathrop. Slogan, "The Vehicle City." No definite schedule.

WEAB, Fort Dodge, Ia. 360 meters. 600 ml. Standard Radio Equip. Co. Daily ex Sun, markets every 30 min. from 9:40 am-1:20 pm; 5:15 pm, 7-8 music; 8:35 markets; 9:45, weather. Sat, 10-11:15 pm, dance music. Sun, 10:30 am, 4:30 pm, 7:30, church services. Central.

WEAD, Atwood, Kan. 263 meters. N. W. Kansas Radio Supply Co. Temporarily discontinued.

WEAE, Blacksburg, Va. 360 meters. Polytechnic Inst. A. T. & T. Co. Slogan, "A Voice to the Millions." Daily ex Sun, 11-12 am, 4:30-5:30 pm, 7:30-10. Sun, 3:15 pm, Fri, 7-10. Eastern Daylight Saving.

WEAG, Edgewood, R. I. 231 meters. Nicholas-Hine-Beckett Lab.

WEAH, Wichita, Kan. 360 meters. 500 ml. Lander Radio Co. Daily ex Sun, 9:40 am, 10:40, 11:40, 12:40 pm, 2 reports. Wed, Sat, 8 pm, concert. Every third Sun, 8 pm, concert. Central.

WEAI, Ithaca, N. Y. 268 meters. Cornell Univ.

WEAJ, Vermillion, S. D. 360 meters. Univ. of S. D. Temporarily discontinued.

WEAK, St. Joseph, Mo. 360 meters. 100 ml. Julius B. Abercrombie. Daily ex Sun, 5:15-6 pm, Central.

WEAM, North Plainfield, N. J. 252 meters. 75 ml. Borough of N. Plainfield. Daily, 7:30-8 pm, music, police news, etc. Eastern.

WEAN, Providence, R. I. 360 meters. 50 ml. The Shepherd Co. Daily ex Sun, Mon, 12-1 pm, 4-5, 6-8, music, weather, concerts. Tues, Thurs, 8:15-10, concert. Wed, Sat, 7-8 pm, concert. Sun, 10:45-11:30 am, 7:30-8:45 pm, church service. Eastern Daylight Saving.

WEAO, Columbus, O. 360 meters. 1,000 ml. Ohio State Univ. Daily ex Sun, 1:30 pm, 4:30, reports, music. Thurs, 9 pm, lecture, concert. Eastern.

WEAP, Mobile, Ala. 360 meters. 50 ml. Mobile Radio Co. Daily ex Sun, 12 m, reports; 4-5 pm, music. Daily ex Sun, Mon, 7:45-8:45 pm, music. Sun, 3-3:30 pm, church service. First Mon of each month, 11 pm-1 am, concert. Central.

WEAR, Baltimore, Md. 360 meters. 200 ml. News & American Pub. Co. Daily ex Sun, 6:30-7, weather, music, news. Tues, Thurs, 7:30-9:30 pm. Eastern.

WEAS, Washington, D. C. 360 meters. 200 ml. The Hecht Co. Daily ex Sun, 3-4 pm. Wed, Fri, 7-8 pm. Eastern.

WEAU, Sioux City, Ia. 360 meters. 300 ml. Davidson Bros. Co. Slogan, "The Heart of the Corn Belt." Daily ex Sun, 9 am, 10, 11, 1 pm, 5, markets, news. Mon, Wed, Fri, 8-9 pm, concert. Sun 7-9 pm. Central.

WEAV, Rushville, Nebr. 360 meters. 200 ml. Sheridan Elec. Service Co. Wed, Fri, Sun, 8-9 pm, concert, news, etc. Mountain.

WEAX, Little Rock, Ark. 360 meters. T. J. M. Daly Bros. Co. Daily ex Sun, 10 am, 11, 2, 5 pm, reports, markets, news. Mon, Wed, Fri, 8 pm, concert. Sun, 7 pm, church service. Central.

WEAY, Houston, Tex. 360 meters. 1,510 ml. Will Horwitz (Iris Theater). Slogan, "Where All the Oceans Meet All the Railroads." Daily ex Sun, 1 am, dinner hints, news; 12 m, music; 12:57-1 pm, time; 2:30 pm, music, 6 pm, news. Wed, Fri, 8-10 pm, concert. Sun, 11 am, 8 pm, church services; 9 pm, concert. Central.

WEB, St. Louis, Mo. 360 meters. 800 ml. The Benwood Co., Inc. Daily ex Sun, 9-9:40 am, 12-12:45 pm, 3-4. Wed, 7-9 pm, Central.

WEN, Tulsa, Okla. (300 S. Main St., Eldorado, Kans.) Midland Refining Co.

WEV, Houston, Tex. 360 meters. 500 ml. Hurlbut-Still Elec. Co. Daily ex Sun, 10 am, 5:30 pm, weather, roads. Tues, Thurs, 8 pm, concert. Central.

WEW, St. Louis, Mo. 261 meters. 100 ml. St. Louis Univ. Daily ex Sun, 9 am, 10, 2, 5 pm, reports. Central.

WEY, Wichita, Kan. 360 meters. 500 ml. Cosradio Co. (Wichita Beacon). Daily ex Sun, hourly, 8:40 am-12:40 pm, stock markets. Daily, 10:45 am and 4:30 pm, weather; 8-10 pm, sports, concert, lecture; 10:45 weather. Sun, 8-10 pm, church service, concert. Central.

WFAC, Dallas, Tex. 476 meters. 1,500 ml. Dallas News and Dallas Journal. Slogan, "Working for All Alike." Daily ex Sun, 12:30-1 pm, address; 6:15-7, bedtime story; 8:30-9:30, music. Tues, Thurs, Sat, 11-12 pm, music. Sun, 2:30-3:30 pm, bible class; 9:30-10:30 pm, music. Central.

WFAB, Syracuse, N. Y. 234 meters. 100 ml. C. F. Woese. No definite schedule.

WFAC, Superior, Wis. 360 meters. 400 ml. Superior Radio Co. Daily, 7-7:45 pm, news. Central.

WFAD, Poughkeepsie, N. Y. 273 meters. H. C. Sprattley Radio Co. Temporarily discontinued.

WFAG, Waterford, N. Y. 360 meters. 300 ml. Radio Engineering Lab. Wed, Sat, 7:45-10 pm, concert. Sun, 2-4 pm, church service. Eastern.

WFAH, Port Arthur, Tex. 360 meters. 100 ml. Elec. Supply Co. Tues, Thurs, 10-11 pm, concert. Central.

WFAI, Asheville, N. C. Hi-Grade Wireless Instrument Co.

WFAM, St. Cloud, Minn. 360 meters. 100 ml. Granite City Elec. Co. Daily ex Sun, 3:30-4 pm, markets. Mon, Wed, 7:30-9 pm, entertainment. Central.

WFAN, Hutchinson, Minn. 360 meters. 300 ml. Hutchinson Elec. Service Co. Slogan, "The Gateway to the Ten Thousand Lakes of Minn." Daily, 11:57-12:20, time, weather. Tues, Wed, 8:30 pm, concert. Sun, 2:30 pm. Central.

WFAO, Cameron, Mo. 360 meters. 300 ml. Cameron Radio Co. Daily, 7-7:45 pm, news. Central.

WFAF, Washington, D. C. 360 meters. 75 ml. Sprattley Radio Co. Temporarily discontinued.

WFAH, Waterford, N. Y. 360 meters. 300 ml. Radio Engineering Lab. Wed, Sat, 7:45-10 pm, concert. Sun, 2-4 pm, church service. Eastern.

WFAI, Lincoln, Nebr. 360 meters. 300 ml. Univ. of Nebr. Slogan, "The Home of the Cornhuskers." Daily ex Sun, 10:00 am, 12:40 pm, weather. Mon, Thurs, 8 pm, lectures. Tues, 8 pm, concert. Central.

WFAJ, Charleston, S. C. 360 meters. 400 ml. S. C. Radio Shop. Daily ex Sun, 12 m, reports, news; music. Tues, Thurs, 8-10 pm. Eastern.

WFI, Philadelphia, Pa. 395 meters. 1,000 ml. Strawberry & Clothier. Daily ex Sun, 10 am, reports; 1 pm, news; 2, music; 3-4:30, concert; 7-7:30 children's hour. Tues, Thurs, Sat, 8 pm, concert. Wed, 10:30 pm, dance music. Sun, 9:30 pm, organ recital. 7:30, church services. Eastern Daylight Saving.

WGA, Tulsa, Okla. 360 meters. Goller Radio Service.

WGAL, Lancaster, Pa. 248 meters. 35 ml. Lancaster Elec. Supply & Construction Co. Slogan, "Garden Spot of U. S. A." Mon, Wed, Fri, 7:30-9 pm, concert, lecture. Sun, 3-3:30 pm, church service. Eastern.

WGAM, Orangeburg, S. C. 360 meters. 150 ml. Orangeburg Radio Equipment Co. Daily ex Sun, 10 am, markets, weather; 11:55, time; 4 pm, Radio talk, markets, sports; 8, music, lecture; 10, time, weather, entertainment; 11, church service; 11:55, time; 10 pm, time, weather, music. Eastern.

WGAP, Shreveport, La. 360 meters. 500 ml. Glenwood Radio Corp. Daily ex Sun, 5:30-6 pm, 8, music. Sun, 11 am, 7:30 pm, church service. Central.

WGAR, Fort Smith, Ark. 360 meters. Southwest America.

WGAU, Wooster, O. 226 meters. Marcus G. Limb.

WGAX, Altoona, Pa. 261 meters. Ernest C. Albright.

WGAY, Washington, D. C. 360 meters. 75 ml. Radio Elec. Co. Daily ex Sun, 12 m, music, news; 9:30 pm, concert, news. Sun, 10:30 pm, sermon. Central.

WGAY, Madison, Wis. 360 meters. 100 ml. North Western Radio Co. Daily ex Sun, 10 am, weather; 11:30, news; 1 pm, Univ. activities; 4:30, news. Sun, 10:30-12 am, sermon. Central.

WGAZ, South Bend, Ind. 360 meters. 200 ml. South Bend Tribune. Daily ex Sun, 9-9:30 am, household hints, menus; 5-5:30 pm, music. Tues, Thurs, Sat, 7-8 pm, music. Central.

WGF, Des Moines, Iowa. 360 meters. Register and Tribune. Slogan, "The Convention City." Tues, Fri, 7:30 pm, entertainment. Sat, 10 pm, music. Sun, 5 pm, church service. Central.

WGI, Medford, Hillside, Mass. 360 meters. 500 ml. Am. Radio & Research Corp. Slogan, "Amrad, the Voice of the Air." Daily, 5-6:45 pm, Children's Hour, reports, codes. Daily ex Sun, Mon, 8:30 pm, concert. Tues, Fri, 3 pm, Amrad Women's Club. Sun, 4-5 pm, 8:30, church services; 9, concert. Eastern Daylight Saving.

WGL, Philadelphia, Pa. 360 meters. 2,000 ml. Thos. F. J. Howlett. Tues, Thurs, Sat, 7:45-11:30 pm, concert. Eastern Daylight Saving.

WGM, Atlanta, Ga. 429 meters. 1,500 ml. The Atlanta Constitution. Daily ex Sun and Wed, 6-7 pm, orchestra concert; 9:30-10:30 pm, music. Sun, 3:30-4:30 pm, organ recital; 9:30-10:30 pm, music. Wed, 12-1 am, concert. Central.

WGR, Buffalo, N. Y. 319 meters. 1,000 ml. Federal Tel. & Teleg. Co. Slogan, "The City of Opportunity." Daily ex Sat, 12:15 pm, weather; (Mon, Thurs, agriograms); 2, 3, 4, 5, music, reports; Mon, Wed, Fri, 8-10 pm, concert. Sun, 3 pm, vesper services. Eastern Daylight Saving.

WGV, New Orleans, La. 350 meters. 400 ml. Interstate Elec. Co. Slogan, "Where the Mighty Mississippi Makes a Crescent Near the Gulf." Mon, Wed, Sat, 8-9 pm, 12-1, music, talks. Sat, 7:30-8:30 pm. Central.

WGY, Schenectady, N. Y. 360 meters. 1,000 ml. General Elec. Co. Daily ex Sun, 11:30-12 m, 5, 10, reports, time, sports. Mon, Tues, Thurs, Fri, 1-1:30 pm, 7:45 concert. Sat, 8 pm, special. Fri, 10:30 pm, special. Sun, 9:30 am, 3 pm, 6:30 pm, church service. Eastern.

WHA, Madison, Wis. 360 meters. 1,000 ml. Univ. of Wis. Daily ex Sun, 11:59-12 m, time signals, weather. Daily ex Sat, Sun, 7 pm, lectures, news. Mon, Thurs, 7:30 pm, agriograms, concerts, sports. Sat, 12:15-1 pm, music, codes. Sun, 1:30-2:30 am, concert. Central.

WHAA, Iowa City, Ia. 263 meters. 200 ml. Univ. of Iowa. No regular schedule. Central.

WHAB, Galveston, Tex. 360 meters. 500 ml. Clark W. Thompson Co. Slogan, "The Gateway to the Southwest and Treasure Island of America." Daily ex Sun, 9:45 am, 11, 3:30 pm, 5, reports, music, news. Tues, Thurs, Sat, 8 pm, entertainment. Sun, 11 am, 7:30 pm, church service. Central.

WHAC, Waterloo, Ia. 360 meters. 150 ml. Cole Bros. Elec. Co. Daily, 6 pm, news, sports. Mon, Wed, Fri, 9:30 pm, concert. Sun, 11 am, church services. Central.

WHAD, Milwaukee, Wis. 360 meters. 100 ml. Marquette Univ. Wed, 7:30-8:30 pm, music, entertainment. Central.

WHAE, Sioux City, Ia. 200 ml. Automotive Elec. Service Co. Daily ex Sun, 12:30-5:30 pm, music, reports. Thurs, 7:30 pm, music. Central.

WHAG, Cincinnati, O. 222 meters. 100 ml. Univ. of Cincinnati. No definite schedule.

WHAH, Joplin, Mo. 360 meters. Hafer Supply Co.

WHAI, Davenport, Ia. 360 meters. 30 ml. Radio Equip. & Mfg. Co. Temporarily discontinued.

WHAK, Clarksburg, W. Va. 360 meters. Roberts Hdwr. Co. 50 ml. No definite schedule.

WHAL, Lansing, Mich. 248 meters. 200 ml. The Capital News. Daily ex Sun, 12:30 pm, 2:55, 4:30, Mon, Wed, Fri, 7:45 pm. Sat, 12 midnight. Sun, 2:30 pm. Central.

WHAM, Rochester, N. Y. 360 meters. Univ. of Rochester.

WHAO, Savannah, Ga. 360 meters. 100 ml. Frederick A. Hill. Daily, 8-9 pm. Eastern.

WHAP, Decatur, Ill. 360 meters. 100 ml. Otto & Kuhns. No definite schedule.

WHAR, Washington, D. C. 242 meters. 75 ml. Seneca Motor Co. Mon, 7-8 pm, lecture on automobile upkeep, music. Eastern.

WHAS, Louisville, Ky. 400 meters. 1,500 ml. Courier Journal and Louisville Times Co. Daily ex Sun, 4-5 pm, 7:30-9. Sun, 9:57-10:45 am, 4-5 pm, church service. Mon night, silent. Central.

WHAV, Wilmington, Del. 360 meters. 200 ml. Wilmington Elec. Spec. Co. Slogan, "The First Broadcasting Station of the First City of the State." No definite schedule. Central.

WHAW, Tampa, Fla. 360 meters. 200 ml. Pierce Elec. Co. Temporarily discontinued.

WHAY, Huntington, Ind. 360 meters. 75 ml. Huntington Pub. Co. Daily ex Sun, 12 m-12:30, weather, 3 pm, music; 6 pm, markets, news, weather, sports. Mon, Wed, Fri, 8 pm, concert. Sun, 3 pm, sermon; 4 pm, concert. Central.

WHAZ, Troy, N. Y. 380 meters. 2,000 ml. Rensselaer Polytechnic Inst. Slogan, "Transcontinental and International Broadcasting Station. Located at the Oldest School of Engineering." Club, R. P. P. Mon, 9-10:30 pm, music. Transcontinental second Monday of each month, 12:13-30 am, music. Eastern.

WHB

ADVANCE PROGRAMS

(Continued from page 7)

Leaders of the Old Testament, Dr. Robert S. Hyer, Southern Methodist University; 8:30-9:30 P. M., Musical program; Walter J. Fried, violinist, and assisting artists. WFI (Eastern, Daylight Saving, 395), 1:00 P. M., Dinner music, Meyer Davis Bellevue-Stratford Concert Orchestra; 3:00 P. M., Concert; 5:20 P. M., Baseball scores; 6:30 P. M., Dinner music, Meyer Davis Bellevue-Stratford Concert Orchestra; 7:00 P. M., Stories, Cousin Sue. WGI (Eastern, Daylight Saving, 360), 8:30 P. M., Silver-Smith series, David M. Cheney; "Oliver Ditson Night," Amrad Choral Club; Amrad Banjo-Mandolin Club; Amrad Orchestra. WGY (Eastern, 380), 1:00 P. M., Talk, "Olecloth Labor-Savers for Summer Homes"; 7:35 P. M., Talk, "Swimming—Its Dangers and Benefits," State Dept. of Health; 7:45 P. M., Radio drama, "It Pays to Advertise," WGY Players; 10:30 P. M., Musical program, "Susan Jane," "The Yaller Gal That Winked at Me," WGY Orchestra; "Nobody Knows the Trouble I've Seen," Calhoun Colored Trio; "High Jinks," Kitty Meinhold, pianist; Go, Mary, Toll the Bell, trio; "Darling Nellie Gray," Edward Rice, violinist; "Steal Away," trio; "Water Scenery," "Gimme Selection," Kitty Meinhold; "All the Way to Calvary," trio; "Pickles," Kitty Meinhold; "Old Ark Amoverin," trio; "Southern Overture," orchestra. WHAS (Central, 400), 4:00-5:00 P. M., Concert, Mary Anderson Theatre Orchestra; 7:30-9:00 P. M., Concert, Manning Hawaiian and Jug Orchestra. WIP (Eastern, Daylight Saving, 509), 3:00-4:00 P. M., Dance program; 6:00-6:45 P. M., Dinner music; 7:00-7:30 P. M., Bedtime stories, Uncle Wip. WMAQ (Central, Daylight Saving, 447), 7:00-8:00 P. M., Stories, Jessie G. Van Cleve; Musical lecture, Mrs. Marz E. Obendorfer; 9:15-10:00 P. M., Musical program, Apollo Male Quartet. WMC (Central, 400), 8:30 P. M., Concert, Walter Moore Mixed Quartet; 11:00 P. M., Midnight Frolic. WOC (Central, 484), 3:30 P. M., Educational talk, C. E. Went; 5:45 P. M., Chimes concert. WOO (Eastern, Daylight Saving, 509), 11:00 A. M., Organ recital, Mary E. Vogt; 12:00-12:55 P. M., Dinner music, Tea Room Orchestra; 4:45-5:00 P. M., Organ recital, Mary E. Vogt; 7:30 P. M., Sporting results; 7:45 P. M., Musical program; 8:00 P. M., WOO Orchestra, Robert E. Golden, director; 9:00 P. M., Organ recital, Mary E. Vogt; 10:00 P. M., Dance music, from Adelphia Roof Garden, Walter Miller, director. WWJ (Eastern, 517), 7:00 P. M., Concert, News Orchestra; Alverna Haas, pianist; Mrs. A. V. Cluff, soprano; Joseph T. Korsenowski, baritone.

Saturday, June 30

CFCA (Eastern, Daylight Saving, 400), 8:00-9:00 P. M., Concert, "Rosamunde," Star Orchestra; "Arensky Trio," Star Trio; Arthur Fisher, baritone; "Mary of Argyll," W. Woods, cornetist; "Herceuse," orchestra; Arthur Fisher, "Valse les Fleurs," orchestra; "Ye Banks and Braes," W. Woods; Arthur Fisher, baritone; "Sempre Fidells," orchestra. KHJ (Pacific, 400), 2:30-3:30 P. M., Matinee musicale; Pasadena Boy Scouts; 6:45-7:30 P. M., Children's Hour; 8:00-10:00 P. M., Musical program, Maybelle Strook, soprano; Isabel Nave, pianist. KYW (Central, Daylight Saving, 345), 8:00-8:58 P. M., Musical program, courtesy of W. W. Kimball Co.; Cope Harvey, orchestra; Wendell W. Hall, KYW's Music Maker; 9:05-9:25 P. M., Under the Evening Lamp, Youth's Companion. WBAP (Central, 476), 7:00-7:30 P. M., Sunday School Lesson, Mrs. W. F. Barnum, First Methodist Church. WDAK (Eastern, Daylight Saving, 395), 12:00-12:54 P. M., Organ recital, Stanley Theatre; 2:00-3:00 P. M., Arcadia Concert Orchestra; Song recital, 4:30-6:00 P. M., Dance program; 7:30-8:00 P. M., Dream Daddy. WFAA (Central, 476), 12:30-1:00 P. M., Address, "Current History Comment," Prof. Clyde Egleton, Southern Methodist University; 8:30-9:30 P. M., Concert, J. I. Wright's Male Quartet; 11:00-12:00 P. M., Musical program, Ruth Fabian and assisting artists. WFI (Eastern, Daylight Saving, 395), 1:00 P. M., Dinner music, Meyer Davis Bellevue-Stratford Concert Orchestra; 3:00 P. M., Concert, Strawbridge Male Quartet; 6:20 P. M., Baseball scores; 6:30 P. M., Dinner music, Meyer Davis Bellevue-Stratford Concert Orchestra; 7:00 P. M., Safety talk, Stanley Cowman; 8:00 P. M., Song and piano recital. WGI (Eastern, Daylight Saving, 360), 8:30 P. M., Talk on New England Business Problems, Arthur E. Currier, Concord. WHAS (Central, 400), 4:00-5:00 P. M., Concert, Mary Anderson Theatre Orchestra; 7:30-9:00 P. M., Myrtle Stinger, soprano; Mrs. Rose Knasel Howe, reader; Hiram Shelley Summers, tenor; Mrs. John T. Quinn, soprano; Margaret Hammerstein, pianist; Mary Anderson Theatre Orchestra; Clifford Gorman, organist. WIP (Eastern, Daylight Saving, 509), 3:00-4:30 P. M., Dance program; 6:00-6:45 P. M., Dinner music; 7:00-7:30 P. M., Bedtime stories, Uncle Wip; 8:00 P. M., Short talks; Recital; 10:10 P. M., Dance music, Charito Kerr's Cafe L'Aiglon Orchestra. WMAQ (Central, Daylight Saving, 447), 7:00-8:00 P. M., Musical program, Thelma Smithpeter, soprano; Cornelius Shugartman, reader; 9:15-10:00 P. M., Recital, Mme. Ella Spravka, pianist; Prof. Boza Oumiroff, basso. WMC (Central, 400), 8:30 P. M., Concert, Alexander's Fire Aces. WOC (Central, 484), 3:30 P. M., Educational talk, C. C. Hall; 5:45 P. M., Chimes concert, 8:00 P. M., Talk, J. E. Gorman, president of Chicago, Rock Island and Pacific Railway; 9:30-10:30 P. M., Dance music, P. S. C. Orchestra. WOO (Eastern, Daylight Saving, 509), 11:00 A. M., Organ recital, Mary E. Vogt; 12:00-12:55 P. M., Dinner music, Wanamaker Tea Room Orchestra; 4:45-5:00 P. M., Organ recital, Mary E. Vogt; 7:30 P. M., Sporting results. WWJ (Eastern, 517), 7:30 P. M., Concert, Schmeman's Band.

Sunday, July 1

WFAA (Central, 476), 2:30-3:30 P. M., Radio Chapel, Dr. William M. Anderson, Jr., pastor First Presbyterian.

Premier "HEGEHOG" AUDIO FREQUENCY TRANSFORMER. TRADE MARK. HALF SIZE. PAT. PEND. MAXIMUM VOLUME MINIMUM DISTORTION 100 PER CENT SHIELDED MOUNTS ANYWHERE. PRICE \$3.50. RATIOS—1 to 3, 1 to 4, or 1 to 5. AT ALL GOOD DEALERS OR POSTPAID DIRECT ANYWHERE IN THE U. S. A. Engineers Say the Most Wonderful Transformer Yet Designed. Full Specifications on Request. Premier Electric Company. Established 1905. 3810 Ravenswood Avenue, CHICAGO, ILL.

ian Church, teacher; 9:30-10:00 P. M., Sacred recital, Haskell Ave. Methodist Church; 10:00-11:00 P. M., Concert, William C. Hallback's Orchestra. WGI (Eastern, Daylight Saving, 360), 4:00 P. M., "Adventure Hour," Youth's Companion; Concert, Miriam Stanley Carleton, soprano and violinist; 8:30 P. M., Talk on World Unity, conducted by Mass. Federation of Churches; 9:00 P. M., Musical program. WGY (Eastern, 380), 9:30 A. M., Church services, First Baptist Church, Besseler, N. Y.; Sermon, "The God-Man Christ Jesus," Rev. William S. V. Robinson; 6:30 P. M., Church services, First Baptist Church; Sermon, "What Does the Cross of Christ Mean to You?" Rev. William S. V. Robinson. WHAS (Central, 400), 9:57 A. M., Organ music; 10:00 A. M., Church services, Fourth Ave. Presbyterian Church, Rev. Dr. Charles W. Welch, pastor; William E. Coner, organist; Mrs. Newton G. Crawford, soprano; Mrs. Virginia Shafer Herrick, alto; H. Archer Culmer, tenor; Peter Schlicht, baritone; 4:00-5:00 P. M., Concert under auspices of Nina Hazelrigg. WIP (Eastern, Daylight Saving, 509), 11:00 P. M., Church services, Holy Trinity Chapel; Ernest Felix Potter, organist. WMC (Central, 400), 11 A. M., St. Mary's Episcopal Cathedral services. WWJ (Eastern, 517), 7:30 P. M., Church services, St. Paul's Cathedral; 2:00 P. M., News Orchestra; 3:00 P. M., Concert, Schmeman's Band.

Monday, July 2

WDAK (Eastern, Daylight Saving, 395), 12:00-12:54 P. M., Organ recital, Stanley Theatre; 2:00-3:00 P. M., Recital, Talk, "Affairs of the Heart," Betsy Logan; 4:30-5:00 P. M., Musical selections; 7:30-8:00 P. M., Dream Daddy; 8:00 P. M., Dance music, Howard Lanin's Arcadia Cafe Dance Orchestra. WFI (Eastern, Daylight Saving, 395), 1:00 P. M., Dinner music, Meyer Davis Bellevue-Stratford Concert Orchestra; 3:00 P. M., Concert; 6:20 P. M., Baseball scores; 6:30 P. M., Meyer Davis Bellevue-Stratford Concert Orchestra; 7:00 P. M., Stories, Cousin Sue. WGY (Eastern, 380), 1:00 P. M., Talk, "How to Deal with the Clothes Moth," courtesy of Modern Friscilla; 7:45 P. M., Musical program; "Deux Polonaises," Helen K. Ryan, pianist; "The Old Sweetheart of Mine," Anne F. Brubaker, reader; "Robin Sing a Merry Tune," Beulah Daughtlart, soprano; "Serenata," Raymond F. Rooney, violinist; "Calls," Anne F. Brubaker; "Etude Japonaise," Helen K. Ryan; "A Heart of Gold," "Birth of Dawn," Beulah Daughtlart; "Spanish Dance," Raymond F. Rooney; "Little Boy Blue," "Teddy Bear," Anne F. Brubaker; "My Sunshine," Beulah Daughtlart; "Impromptu," Helen K. Ryan. WHAS (Central, 400), 4:00-5:00 P. M., Concert, Mary Anderson Theatre Orchestra; "Just Among Homo Folks," Courier-Journal; Clifford Gorman, organist. WIP (Eastern, Daylight Saving, 509), 1:00-2:00 P. M., Organ recital, Karl Bonawitz; 4:00-5:00 P. M., Recital; 6:00-6:45 P. M., Dinner music; 7:00-7:30 P. M., Bedtime stories, Uncle Wip. WMC (Central, 400), 8:30 P. M., Concert, Hotel Gayoso Orchestra. WOO (Eastern, Daylight Saving, 509), 11:00 A. M., Organ recital, Mary E. Vogt; 12:00-12:55 P. M., Dinner music, Tea Room Orchestra; 4:45-5:00 P. M., Organ recital, Mary E. Vogt; 7:30 P. M., Baseball scores; 8:30 P. M., Musical program.

SPECIAL OFFER LIST

(Continued from page 2) Dubilier Micadon Type 610 (.01 or .02 mfd.); Dubilier By-Pass Condenser (1 mfd.), Premier Universal Radio Jack, Filament Control Five Spring; CRL Variable Grid Leak, without condenser; Premier No. 250 Variable Resistance, panel mounting. Class D Articles For eight consecutive coupons and one dollar and twenty cents (\$1.20) any one of the following articles will be sent: 1 Carter 20-Ohm Vernier Control Rheostat; 1 Schindler Radio Frequency Transformer; 1 Martin-Copeland 13-Point Inductance Switch; 1 Martin-Copeland 15-Point Inductance Switch; 1 Martin-Copeland 19-Point Inductance Switch; Walnart Variable Condenser (5-Plate .0001 mfd.); Ray-O-Vac No. 4151 B Battery, 22½ volts; Ray-O-Vac Dry Battery, 3 cells 4½ volts; Electrad Variomik with mica condenser; Dubilier By-Pass Condenser (2 mfd.); CRL Variable Grid Leak with Condenser; Resistometer (Type A or 2A). Class E Articles For ten consecutive numbered coupons and one dollar and fifty cents (\$1.50) any one of the following articles will be sent: 1 Carter 6-Ohm Automatic Control Rheostat; 1 Carter 20 Ohm Automatic Control Rheostat; 1 Decima 3-Plate Variable Condenser; Walnart Variable Condenser (13-Plate .00025 mfd.); Ray-O-Vac Dry Battery, 4 cells 1½ volts; Dubilier Variodon (.0004 or .0006 mfd.); Resistometer (Type B); Delta Midget Tube and Socket.

CUNNINGHAM TUBES REPAIRED

Table listing tube repair prices: C-300 or UV-200...\$2.75, C-201 or UV-201...3.00, C-302 or UV-202...3.50, C-201A or UV-201A...3.50, WD-11 or WD-12...3.50, Moorehead Detectors...2.75, Moorehead Amplifiers...3.00, DV-6 or DV-6A...3.50, Also the new UV-109...3.50, NEW DX 1/2 VOLT TUBES...4.00. All tubes guaranteed to work like new. Mail Orders Given Prompt Attention "24 Hour Service".

RADIO TUBE CORP. 55 Halsey Street Newark, N. J. TUBES SENT PARCEL POST, C. O. D.

THE NEW B-T VERNIER TUNER. Gives 100% Improvement on REINARTZ CIRCUITS. Does away with soldered taps, switch points, etc. Easy to change to other circuits if desired. Photo Diagrams furnished—ask your dealer, or write for circular. "IT'S A BEAUT". BREMER-TULLY MFG. CO. 532 South Canal Street CHICAGO

Class F Articles

For twelve consecutively numbered coupons and one dollar and eighty cents (\$1.80) the following will be sent: 1 Acme Pot-Rheo (potentiometer and rheostat); Walnart Variable Condenser (23-Plate .0005 mfd.); Ray-O-Vac No. 2151 B Battery, 22½ volts; Dubilier By-Pass Condenser (3 mfd.); Premier Variable Condenser without dial (.00039 mfd.).

Class G Articles

For fourteen consecutively numbered coupons and two dollars and forty cents (\$2.40) any one of the following articles will be sent: 1 Federal 7-Plate Variable Condenser; 1 Federal 11-Plate Variable Condenser; 1 Federal 21-Plate Variable Condenser; 1 Federal Antiparity Switch; 1 Decima Variable Condenser 11-Plate Walnart Variable Condenser (43-Plate .001 mfd.); Dubilier Variodon (.001 mfd.); Dubilier By-Pass Condenser (4 mfd.); Premier Variable Condenser with dial (.00078 mfd.); Premier Hegehog A. F. Transformer, 4 to 2 Ratio.

Class H Articles

For sixteen consecutively numbered coupons and three dollars (\$3.00) any one of the following articles will be sent: 1 Federal Audio Frequency Transformer No. 228 W; 1 Decima 23-Plate Variable Condenser; 1 Acme Audio Frequency Transformer; 1 Acme Radio Frequency Transformer (R-2, R-3, or R-4); Walnart Variable Condenser (18-Plate vernier; Walnart Variable Condenser (23-Plate Vernier); Ray-O-Vac No. 2301 "B" Battery 45 volts; Ray-O-Vac Dry Battery, 6 cells ½ volts; Dubilier Duratran (R. F. transformer); Premier Micrometer Variocoupler with dial; Premier Variable Condenser with dial (.0015 mfd.); Premier Variable Condenser with vernier (.0004 mfd.); Premier Hegehog A. F. Transformer, 10 to 1 Ratio; Premier Hegehog A. F. Transformer, Tube Socket Type, 4 to 1 Ratio; Turney Spider Web Coil Mount, Type B.

FLEWELLING ANSWERS

By E. T. Flewelling (Editor's Note.—This department is written by Mr. Flewelling, the inventor of the famous super circuit. From the questions sent him each week care of Radio Digest, he picks the one considered most informative for all and answers it in this column.)

Winding Variocoupler Rotor

(Submitted by A. W. O., Winnipeg, Canada.) Question.—In making the variocoupler for the Flewelling Super I find that it is impossible to place 100 to 130 turns of No. 28 or 30 DCC wire on the rotor if I use the standard size ball. Should I bank-wind the coil or should I use fewer turns?

Answer.—The rotor may be wound to the required number of turns by the use of smaller wire. The size will have no practical electrical effect and one may as well use small sized wire as large. As the space is small the small sized wire would naturally be preferable, because if larger wire is used it will necessitate bank winding the coil and this only adds much work without any compensating returns. If the builder has a standard variocoupler I would recommend that the hook-up be tried before changing the coupler. The Super will work with a standard coupler unchanged and while the results will be below par, yet one will become more familiar with the action without so much work. After this has been done you will know what to expect when you rewind the coupler and will be more sure of yourself.

Reviews of Books

The Armstrong Super-Regenerative Circuit. By George J. Eltz, Jr., E. E. This is a De Luxe edition of this famous circuit. Profusely illustrated and fully explained. Fifty-two pages. Price, \$1.

How to Retail Radio. A new book telling of tested plans and methods and policies for the dealer in Radio. Financing, location, store equipment and arrangement. Price, \$2.

The Radio Amateur's Handbook. By A. Frederick Collins. A new revised edition of this book is just out. It is complete, authentic and informative work on Radio. Fully illustrated. Price, \$1.50.

Radio First Aid. Illustrated with working drawings and complete data as to the necessary equipment and cost of constructing from the simplest to the most modern Radio outfits at home. Price, \$1.

Home Radio—How to Make It. By A. Hyatt Verrill. This book is particularly adapted for the amateur who desires to know how to make Radiophones. Twelve full page illustrations and diagrams. Price, 75 cents.

The book department of the Radio Digest is prepared to send you any of the books on Radio published, whether listed in our Book Review or not. Let us know what book you want, send us your check and we will see that the book is mailed to you. Postage stamps in payment for books not accepted. Send money order or check. Radio Book Department, Radio Digest, 123 W. Madison St., Chicago, Ill.

Electric Soldering Iron. \$2.50. A. C. OR D. C. CURRENT. DEALERS—Attractive Discounts. HUDSON-ROSS 123 W. Madison St. Chicago

BUILD YOUR OWN SET THE LARGEST RADIO STORE IN AMERICA

ACCORDING TO OUR INSTRUCTIONS RESULTS GUARANTEED—PANELS ON ALL SETS DRILLED—READY TO MOUNT

Table of radio parts prices. Columns include: Complete Parts for Knocked-Down Receiving Set \$17.95, Complete Parts for Reinartz Sets \$11.45, Complete Parts for 2 Step Amplifier \$12.45, Complete Parts for Single Tube Reflex Circuit \$32.65. Lists various components like condensers, transformers, and tubes with their respective prices.

We guarantee all merchandise purchased of us. Mail orders receive immediate attention. BUY HERE FOR LESS CHICAGO SALVAGE STOCK STORE 509 South State Street Dept. R. D. CHICAGO, ILLINOIS

Radio Digest Illustrated

REG. U. S. PAT. OFF.

Published by the Radio Digest Publishing Company, Inc.
123 West Madison Street
Telephone State 4844-4845
Chicago, Illinois

E. C. RAYNER, Publisher
Chas. F. Smisor, Editor
Evans E. Plummer, Managing Editor
Harry J. Marx, Technical Editor

Eastern Representative, Jacob Miller, Times Bldg., Times Square,
New York; Telephone Bryant 4909

Pacific Coast Representatives
E. J. Wood, 251 Kearney St., San Francisco
Telephone Kearney 1472
H. M. Morris, 417 Western Mutual Life Building, Los Angeles
Telephone 12011



PUBLISHED WEEKLY

SUBSCRIPTION RATES
Yearly.....\$5.00 Foreign.....\$6.00
Single Copies, 10 Cents

Vol. V Chicago, Saturday, June 30, 1923 No. 12

Farmer Needs Weather Forecast

Aids in the Care of and Disposal of Crops

THERE are many operations on the farm that depend on weather conditions. If the farmer has a receiving set he now can learn the weather forecasts almost as quickly as they are formulated at the weather bureau. Spraying, haying and shipping produce are some of the questions that may be answered by the bureau. Until recently this information was transmitted to the farmer mostly by telegraph and telephone. Often it happened that the more isolated farmer received the information a day or so too late to do him any good. Now the bureau has developed the service until it practically covers the entire country. Special bulletins from the department, treating on various agricultural subjects are also sent out from the stations as often as they are issued.

Refinement of Speech Required

Looks Not Necessary in Broadcast Oratory

SOME of the artists who have taken part in broadcast concerts have told of acute attacks of stage fright. This in spite of the fact that they had for years faced great audiences in the theaters and opera houses. It was a great unknown element in their new audiences that faced them, the fact that their effort was being received by the people at unknown points and with unknown characteristics, for the Radio audience runs from the small boy who makes his own to the most distinguished critic.

Then again, broadcasting personality is badly handicapped. Facial expressions are lost and personal magnetism, other than that of the voice, is lost. It is easy for one who has faced critical audiences to imagine most any kind of listener; to see in the mind's eye someone unsympathetic, someone who does not understand or someone who is cynical and is saying at the distant point, "rotten."

The voice wears few decorations and there are people in the audience measured by the thousands who would much rather hear a good speaker who is a truck driver than a poor one who is a judge or president.

Bugbears Have Vanished

Most of Last Season's Troubles Only History

CONSIDERABLE speculation exists among Radio dealers and fans regarding the extent to which the present tremendous Radio interest will hold the next few months. Thousands of people throughout the United States, who have become Radiophans during the long winter months, will want to keep their interest in this newest of arts and enjoy its benefits during the summer.

Manufacturers and users are co-operating to make Radio suitable for the city dweller as well as for the man or woman who takes to the field and stream or the mountain when their vacation arrives.

Radio is a most fascinating pastime and the thought of each fan is to contrive a way to move his set to the lake shore home, lodge or camp, to his automobile while touring, or to a canoe for a trip through the lakes to the north. The farmer who caters to the summer boarders, is not going to be without a set this season for with interest in markets increasing and programs getting better and better, he will want it for his own use and as an inducement to city dwellers to remain at his home for the evenings.

The lightning and static bugbears are little mentioned this year. The use of the loop aerial eliminates the difficult construction for reception and reduces the static. If the installation is set up beside a lake, fair distances can be covered when the antenna wire, which must be insulated, is submerged. The correct length of the wire in this case must be determined by experiment.

Many sets now use little or no aerial and it is not difficult to receive messages from a portable set at any location. The requirements are few and the entertainment great—take your set with you.

RADIO INDI-GEST

NAME PRIZE EXHIBITION ALMOST STARTS RIOT AT INDIGEST STUDIO

WALLA WALLA.—Swarming multitudes of sun-oscillated, dusky natives nearly precipitated a riot yesterday at the studio of Indigest's great broadcaster here when Mike and Izzy, trained Chimpanzee antenna raisers, brought forth for all to see, the beautiful, genuine brass, bevelled edge, round switch point, the prize to be awarded the lucky Indigest listener fortunate enough to submit the call letters which will be used in all the station's hair-raising broadcasts. The police force of Walla Walla, having been cured of his rheumatism by floating on ether waves, was called out with his uniform on to dispel the confusion. Seeing that he had his badge and that he was in dead earnest, the natives retired. (They retire early in Walla Walla.) The chief head official announcer, Bambin Bray, and musical director, Wattle Knees, however, held a tete-a-tete at four o'clock while teeing and decided that it was in the best interests of Walla Walla that wide publicity be given the marvelous prize offer and inasmuch as Indigest is read by everybody everywhere, why that naturally would be the place to press agent the prize. So that is the reason, after all, my dear children, that the little brown Chimpanzees, Mike and Izzy (sure, he is), have drawn a little teenie picture of the prize for you. Now, everybody look, here it is—

Great interest has already been shown in the naming of the world's best broadcaster. WHO WILL WIN THE PRIZE FOR THE BEST CALL?

In Quest of the Kanooifis Part III—In Egypt

"So this is Egypt? Mummy Land. Kanooifis, where art thou? (Here, Kanooifis, Kanooifis.) We've searched and searched a King's domain. What luck will we have now? (Chuck-a-luck.) Look, yonder is the pyramid, they say the Irish Micks (Glory be to the Irish.) Contend that it was built by them, from ancient Irish bricks." (Some builders, these Irish.) When the shades of night were falling and the sky got black as pitch, (That's kinda dark.) We laid down on the sand to sleep, and woke up with the itch. (What kind?) We were itching to know why we couldn't find that pesky part, (The little devil.)

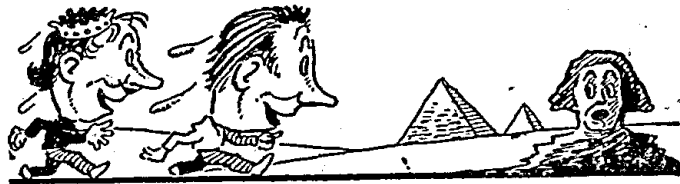

And itching for the U. S. A. from where our search did start. (Who said Chicago?) "Today we'll go to Cairo, they say that in that place, (Some berg.) The girls wear nothing but a smile and a piece of fancy lace. (Oh, boy.) It seems that in our search to find just what we're looking for, (You know.) We cannot find Kanooifis, but find a whole lot more. (Egypt, my Egypt.) We stayed in Cairo just one night, but that was quite enough. (Too much is enormous.) We did not like the maidens there, they treated us too rough. (Can you imagine such Shebas?) So we packed our little grips again, and started on our way, (Good-bye, girls.) But just before we left there, we heard one of them say; (This is news.) She told us if we travelled North, until we reached the West, (Howcom?) We'd find what we were looking for and that would end our quest. (Now, there's a friend for you.) We'd reach a little island, Walla Walla is its name. (Sounds cannibal like.) It might take years to find it, but we'd get there just the same. (The boy can look for it after I'm gone.)

—THIS VERSE BY GOOFY.
(Note: This poem may be sung to the tune of "The Wearin' of the Green." In singing it is considered best form to leave off the remarks at the end of each line. The next edition of Indigest will conclude this epic of contemporary American literature.)

A-B-C Lessons for Indigest Beginners

Chapter II—Th' Battrees fr T'day Are—
BY GOSH

B IS for battery,
Most necessary critter,
That will run down now and then
And leave you hot and bitter.

We Beg to Acknowledge

the following contribution, varied in a very few minor degrees, from most of our regular contributors, including Spider Webb, Ezra Lecht, Z & VK, Algonquin Tonsils III, Polly W., Imp, etc. It runs something like this, if one strikes an average:

"After stalling the wife out of going to the movie and working half the night to make one of your Stebbins De-generative Circuits, we got H—L."

For the purpose of clearness it should be elucidated that the two capital letters separated by two hyphens, represents the call of a very warm station on the other side of the Styx.

Who Invited You, Anyway?

Dear Ind: Very sorry I came back too soon to enter your Sooper contest. I was on a vacation to Walla Walla, where I lamped the erection of your broadcasting station, and must say the isolation is great. I had my 500-watt portable crystal set with me and I heard the cheering and shouting from Lillian G. and her gang (when the Lem. Stebbins prize winners were announced) very silently. E. B. S.

Yes, We Have No Flag-Staff

Indigest's station will be closed down on the Fourth of July at the suggestion of Imp, who says we should put up our flag on the coconut trees, and adds that no self-respecting station should use their antenna towers to hold up aerials on the birthday of Independence. Oh, yes, that's the reason we are using flags instead of dashes, too.

Independence Day

1790

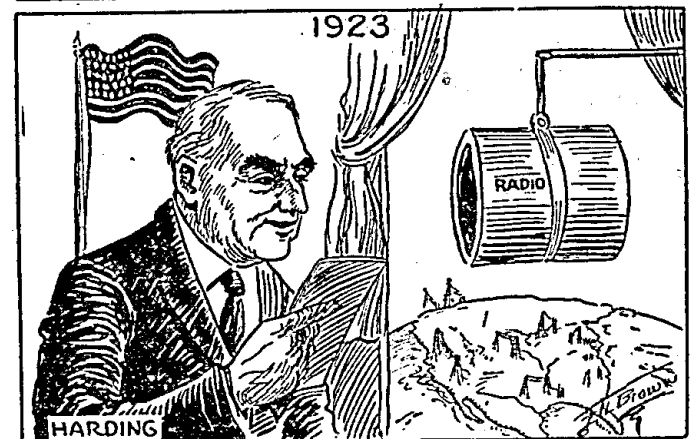

Condensed

By DIELECTRIC

Even three thousand people packing a hall to hear noted speakers and singers does not impress one as it once did. That number would have seemed a large audience before the days of Radio broadcasting, but now! When four great stations picked up the sounds from Carnegie Hall gathered in a single microphone, and sent the address of Mr. Barnes and the sons of Anna Case out into space, so vast an audience heard that those seated in the hall became but a very small part of the whole of listeners-in. What of the future?

Another gem in the Radio Crown of America. This one merits its place from the fact that the Leviathan will carry the greatest Radio equipment of any ship afloat. We purpose to maintain our supremacy on sea as on land in this new field. Not only code messages, but speech as well may be transmitted from this big liner to either shore of the Atlantic; in addition to which, two of her capacious lifeboats will be completely fitted for using Radio.

Station WJAX is well known to the majority of Radiophans in this country by the excellence of their programs. A new and distinctive feature is to be added to their broadcasting rooms which will serve to put the announcer in complete touch with the operator without interfering at all with the work of the artists. Should either of these men be color blind, of course the plan would fail, as the system to be used consists of signal lights of different colors. A phone booth in the studio will permit these two to talk with each other at any time and neither you nor the artists hear them.

To the average person living in the United States the birthday of a king is something which concerns him not at all. He is to be excused for neglecting to keep these monarchic dates in mind. However, many of us were reminded of the fact that King Alfonso, of Spain, celebrates his natal day this time of year through hearing speeches and music broadcast from PWX, Havana, Cuba. It was a celebration in his honor held in the Spanish Casino.

If other cities would copy the plan being put into effect by the Detroit Welfare League we would see many more afflicted ones made happier despite their trouble. Every blind person in the Michigan city is to be supplied with a Radio set, and, as Miss Davis says, "No one can realize what a blessing Radio is to persons without sight." I should like to see a move made in every community in this country with just such an object in view. Who will follow?

And now we have the news of two ships a thousand miles apart on the Pacific ocean treating their passengers to the novel experience of talking with each other from their staterooms, using the ordinary telephone in the room which was plugged in to the Radiophone circuit. These Radio switchboards permit one to talk over his phone to friends aboard ship, or vice versa. It will soon be possible to talk from anywhere to anywhere and—then what?

Perhaps the strongest argument to advance against the claim of those who decry broadcasting of church services is to call attention to Dr. van Etten's custom, and its development. His church in Pittsburgh, Pa., was the first to give to the Radio world regular weekly services. Just recently a bronze tablet was unveiled in the Calvary Episcopal Church, the donors of which were the many who listen in and take part in the Sabbath worship. Nearly five thousand persons gave toward this Radio memorial tablet whose homes are scattered all over America, and even on the high seas.

First Steps for Beginners in Radio

Chapter VII—Vacuum Tube Detectors

By Thomas W. Benson, A. M. I. R. E.

IN describing the action of the vacuum tube detectors it might be well to discuss briefly the underlying principle of rectification that takes place in tubes containing a heated body and a cold electrode. It was first noticed by Edison, in working with the electric lamp, that the globe blackened after use and on experimenting on the action, discovered that when a cold plate was mounted inside the lamp, a current would flow from the cold plate to the filament but not from the filament to the plate. This is due to the fact that a heated filament throws off negative electrons; thus when a battery is connected to the filament and plate with the positive of the

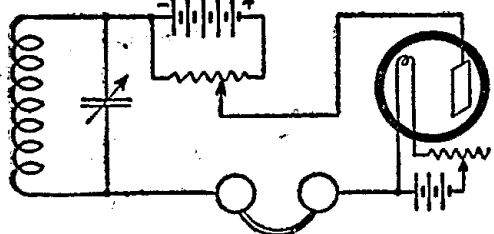

Figure 31—Fleming Valve as Used with Plate Battery

battery connected to the plate a current will flow.

Tube as a Rectifier.

Recalling the action of a crystal detector and its use to rectify the high frequency Radio currents, it would appear that where the secondary tuning circuit of a Radio receiver is connected to the plate and filament of a simple two element tube, a current will flow from the plate to the filament when the plate is positive, but no current will flow when the plate is negative, thus rectifying the current. Fleming tried this experiment and found it worked out satisfactorily and termed his device the Fleming valve. The diode tube is but a modern type of tube employing the same principle. However, the amount of current flowing between the filament and plate through ionized gases does not follow Ohm's law exactly.

It has been found that up to a certain point the current flow varies directly as the voltage between the plate and filament. Beyond this point, termed the saturation point, a slight increase in the voltage on the plate causes a decided increase in plate current. The obvious thing to do then is to maintain the plate at a voltage just below the saturation point, by means of a battery, so that the in-

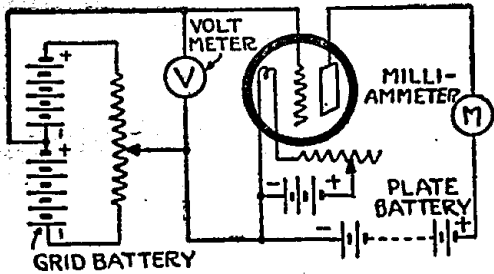

Figure 32—Circuit to Determine Characteristics of Vacuum Tubes and Demonstrate Effect of Inserting Control Element Between Filament and Plate

crease of voltage on the plate by the high frequency current will be sufficient to push the potential over the saturation point and get the maximum response in the phones. A circuit employing this principle is shown in Figure 31 where a potentiometer connected across the plate battery enables the

Ritter \$1 Loop Aerial

Including wood parts—wire and binding posts. Can be assembled or taken apart in a few minutes—Portable, requires little space, 36 inches wide across when put up. Interference—Stable—Lightning practically eliminated. Full instructions sent with every SET. By Mail, 10c Extra.

RITTER RADIO COMPANY
230 Canal Street NEW YORK

BEGINNERS will find the accompanying series by Mr. Benson very helpful in learning the rudiments of the popular science of Radiophony. The articles yet to appear are:

Chapter VIII—The Regenerative Detector.	Chapter XII—Reflex Circuit Operation.
Chapter IX—Radio Frequency Amplification.	Chapter XIII—About Headsets and Loud Speakers.
Chapter X—Audio Frequency Amplification.	Chapter XIV—Batteries Used in Radiophony.
Chapter XI—How Super Regeneration Is Accomplished.	

operator to work the tube at its highest efficiency.

The three element vacuum tube is a similar arrangement but has in addition a grid mounted between the filament and plate to act as a control element and changes the entire action of the device. It should be borne in mind that all three element tubes, comprising a heated filament, a grid or control element, and a cold

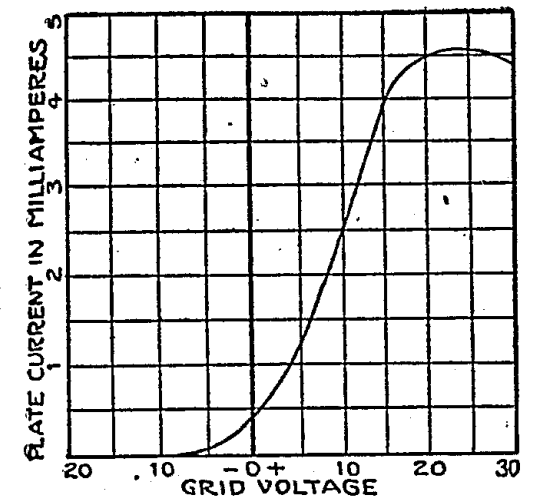

Figure 33—Characteristic Curve of Vacuum Tube Detector Showing Relation Between Changes in Grid Voltage and Current in Plate Circuit

electrode or plate, act in the manner to be described when used as detectors.

The filament is used as a source of negative electrons. A tungsten filament is used in tubes that light up brightly, such as the UV 200, UV 201, DV6 and others, while those that just glow red, such as the WD 12, have a filament coated with a chemical that causes them to emit electrons at a lower temperature. The grid

is a control element and may be mounted outside the tube as in the peanut tube which, by the way, was the first form of control element tried by De Forest, but it is best to place the grid between the filament and the plate. The plate or anode completely encloses the grid and filament in the best types of tubes although it is mounted above the filament when an external control element is used.

Controlling Current.

Now let us consider a three element tube connected as shown in Figure 32. Here we have a constant voltage, say 22 volts, applied to the plate and a potentiometer and battery connected to the grid to change the voltage of the grid with respect to the filament. With the filament lighted and brought up to full brilliancy, the electrons are thrown off from the filament and act to allow a certain plate current to flow. With the potentiometer lever moved to the positive end of the battery, the milliammeter will indicate maximum plate current. This is due to the positive charge on the grid helping to draw the electrons off the filament by electrostatic attraction. Consequently more electrons pass through the grid despite the fact that some strike the grid, increasing the plate current.

As the potentiometer is moved towards the negative end, the plate current will fall off as the positive charge on the grid is decreased. As the neutral point is passed and a negative potential is applied to the grid, the current flow from the filament to the plate further decreases be-

cause the negative charge on the grid repels the negative electrons and will not permit as many to pass through to the plate. The current keeps on decreasing as the negative potential increases till a point is reached at which no current flows from the filament to the plate. At this point the negative charge on the grid is

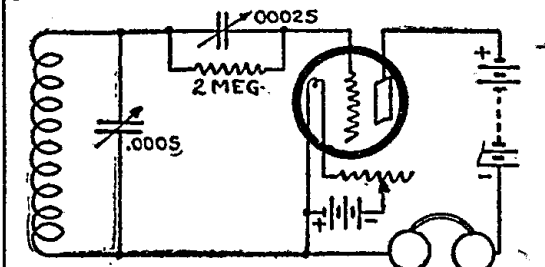

Figure 34—Standard Circuit for Use of Vacuum Tube Detector, Showing Average Values of Capacities and Battery Polarities

strong enough to repel all the electrons and shut off the current.

Were the current in the plate circuit plotted in the form of a curve with respect to the grid voltage, we would have a curve similar to that shown in Figure 33. It will be noted that the curve is flat at the ends and quite steep in the center. This shows that at the higher negative voltage and the higher positive voltage

(Continued on page 14)

WE REPAIR
WD-11, \$3.50
and OTHER
VACUUM TUBES

Excepting
VT-I and VT-II

MAIL ORDERS Solicited and Promptly Attended To

H & H RADIO CO.
516 Clinton Avenue NEWARK, N. J.

a Chi-Rad Special!

for WD-11 tubes—

Standard, threaded rubber, Willard's specially adapted for use with WD-11 Tubes. Supply current at 2 volts to one WD-11 Tube for 210 hours on a single charge. Rechargeable. Brand new, size 4x5½x7 inches—Chi-Rad guaranteed.

2-Volt Willard Charged... \$7.50
2-Volt Willard Dry... 6.50

These same Willards can be adapted to deliver 8 volts for pure D. C. for C. W. Transmitters. Better than a generator because no filter is necessary. Much less expensive.

In lots of 40 (320 volts) . \$160.00
(Better prices on larger quantity)
Specify dry or charged when ordering.

Chicago Radio Apparatus Co.
415 S. Dearborn St. Chicago, Ill.

"Michigan"
Regenerative Radio Receivers
Will Work Wonderfully All Summer

Great progress has been made in Radio in the last year.

The belief that "Radio won't work in hot weather" is now largely dispelled as far as "Michigan" Regenerative Receivers are concerned.

Regeneration, Amplification, Selective Tuning and other special features worked out by us during the past year largely eliminate static and other disturbances.

"Michigan" Regenerative Receivers give superior results when used with any of the dry battery tubes now available.

"SENIOR" SET

"JUNIOR" SET

Take a Michigan Receiver Along With You on Your Summer Vacation Trip. Set One Up on Your Front Porch at Home.

Add this long-distance wonderworker to your other summer pleasures and make the summer of '23 the happiest of your life.

Send for circular describing the wonderful Michigan "Senior" and "Junior" Regenerative Receivers, licensed under Armstrong's U. S. Patent No. 1,113,149 and pending letters patent 807,388 covering the fullest development of regeneration.

Give name and address of your favorite radio Dealer when you write, as we sell thru Dealers only, and want to tell your Dealer friends about our exclusive MRC Franchise.

MICHIGAN RADIO CORPORATION
GRAND RAPIDS, MICHIGAN

Delicate Soldering

Both the manufacturers' and amateurs' problems on all fine work are readily solved by the instrument constructed for this particular purpose.

THE POST SOLDERING IRON
Platinum Heating Unit—Interchangeable Tips—Universal Current
(Large and Small)

\$6 ONE-HALF ACTUAL SIZE

Awarded Certificate of Excellency, N. Y. Evening Mail Radio Institute
From your Dealer, or write

POST ELECTRIC COMPANY (Dept. 509), 30 E. 42nd St., New York

Map Aid in Finding Station Distances

Chart Useful as Record of Broadcasters Heard

Have you any way of quickly finding the distance of any station heard? If not, the illustration shows a practical method. Procure a map of the United

WORKSHOP KINKS? EARN A DOLLAR—

THERE are many little kinks worked out at home that would aid your fellow Radio worker if he only knew about them. There are new hook-ups, new ways of making parts and various unique ways of operating sets that are discovered every day. Radio Digest is very much interested in securing such material. Send them in with full details, including stamped envelope so rejected copy may be returned. The work must be entirely original, not copied.

RADIO KINKS DEPARTMENT,
Radio Digest
123 West Madison St., Chicago, Ill.

States. The pocket maps that sell at the book stores will do very well. Mount this map smoothly on heavy cardboard, building board or some other substantial material. After this is done make a scale from stiff cardboard about one inch wide and long enough to reach on the map from your own town to the farthest border of the United States.

At one end of this scale make a dot and then measure back from this dot equal distances according to the scale upon which the map is drawn, usually about 125 miles to the inch, to show 100 miles for each division. When completed, stick a pin through the dot and pin the scale to the dot on the map representing your station.

By rotating the scale, you can find instantly just exactly the distance from the station heard. You can also check up the distances claimed by the other chaps. By marking this map with colored crayon for every station you have heard you will have an interesting record to show your friends.—H. L. Petersen, Charles City, Iowa.

Distance Easy on Loop

The accompanying hook-up shows a splendid loop set with which I have heard New York, Schenectady, Atlanta, Kansas City and Davenport. So many Radiophans

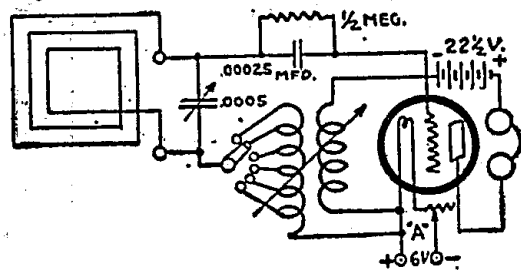

claim loops are not efficient unless used with one or two steps of Radio frequency.

This set is very critical for tuning, but it is highly efficient. As will be noted the tuning is accomplished with a variocoupler with the rotor used for the tickler. A .0005 mfd. condenser—vernier preferred—is shunted across the loop. The vernier rheostat is also of great value.

Owing to extreme regeneration the set will hiss until filament is properly ar-

PATENT ATTORNEYS

PATENTS. Booklet free. Highest references. Best results. WATSON E. COLEMAN, Patent Lawyer, 624 F Street, Washington, D. C.

Build Your Own HAZELTINE NEUTRODYNE with FREED-EISEMANN

Licensed Essential Parts Complete wiring diagram, instructions, etc. sent in special container with patented essential parts. Three NEUTROFORMER COILS mounted on variable condensers, and DOUBLE NEUTRODON (as illustrated), sent for \$21.50. Ask your dealer to show you these parts, as well as complete assembled five-tube Neutrodyne Set in mahogany cabinet, Model NR-5, \$150. Or send 25c for Neutrodyne Constructor which shows "How to Make the Neutrodyne". FREED-EISEMANN RADIO CORPORATION Dept. B 255 Fourth Avenue New York. Licensed by I. R. M. Inc. Under Hazeltine Patents

ROTATING STRIP PINS ON MAP

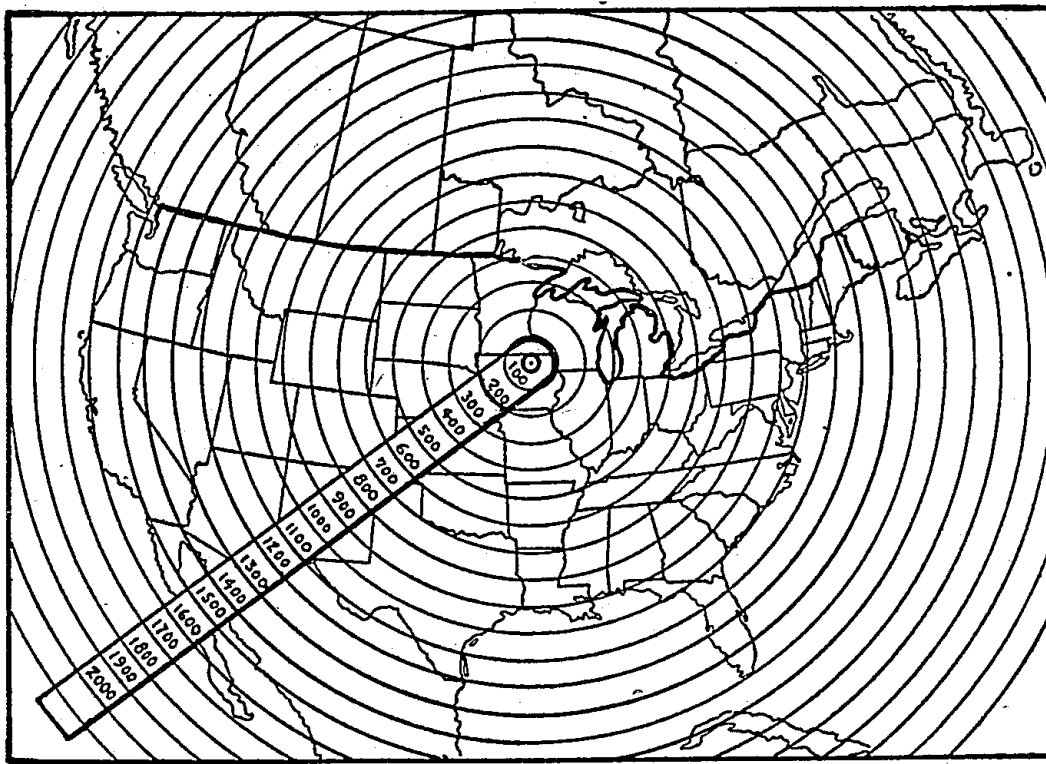

ranged. The grid condenser may be either .00025 mfd. with a 1/2 megohm leak or .0005 mfd. and a 1 megohm leak. Both were tried out with equal success. The diagram is self explanatory.—J. W. Mayfield, Cincinnati, Ohio.

Two Variometer Circuit

The capacitive feed-back method of obtaining regeneration is exceptionally efficient as a receiver of short waves. In a receiver of this type it is customary to connect one variometer in the plate circuit and a second variometer in the grid circuit, the transfer to energy between the plate and grid circuits being effected by utilizing the small capacity existing between the grid and plate elements of the tube itself. Both circuits must be in resonance, that is, tuned to the same wave length, and owing to the fact that variometers provide a continuously variable inductance, it is possible to obtain complete resonance. A condition of resonance is extremely important at high frequencies; that is, short wave lengths, and consequently this type of regenerative circuit is highly efficient for the reception of broadcast signals on wave lengths of from 200 to 600 meters.

Loud Speaker in Auto

NO CUMBERSOME AERIAL REQUIRED

The Ideal portable set weighs only ten pounds, including detector and two stage amplifier with all batteries. Carry it like a camera. Just the set for the auto, camp, or home. Absolutely guaranteed as efficient as any detector and two stage set made, and at a cost of slightly more than some detector sets.

Get our complete instructive catalogue and information on loud speaker for crystal set.

STEINMETZ WIRELESS MFG. CO.
5704 Penn Ave. Pittsburgh, Pa.

DON'T PASS THIS-BUY

World Radio Batteries SAVE YOU 50% WRITTEN 2 YR GUAR

Every World User Is a Booster WRITTEN 2 YEAR GUARANTEE

Because you deal direct with a manufacturer who is responsible for the performance and quality of the Battery.

World-Radio-Batteries
6 Volts—40 Amps., \$8.50
6 Volts—60 Amps., \$10.00
6 Volts—80 Amps., \$12.50
6 Volts—100 Amps., \$14.50
6 Volts \$16.00 120 Amps.
Full Rating Guaranteed
MAIL YOUR ORDER TODAY. WE SHIP EXPRESS C. O. D. SUBJECT TO INSPECTION OR WILL ALLOW 5% FOR CASH WITH ORDER. ALL ORDERS SHIPPED SAME DAY AS RECEIVED.
WORLD BATTERY COMPANY,
60 E. Roosevelt Rd., Dept. L, Chicago, Ill.

Necks of Bottles Make Ideal Small Insulators

It is easy enough to make any quantity of small glass insulators for your lead-in wire at practically no cost at all in the following manner: Remove the necks of small vials, such as vanilla or lemon extract come in, and put them on a nail and fiber washer. The latter, of course, is used to keep the insulator from slipping off the nail. Saturate a cotton string with kerosene and tie it around the neck of the bot-

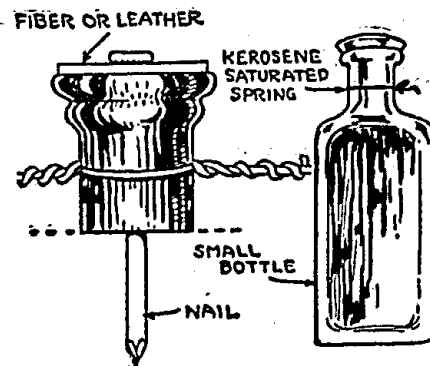

tle where it is to be cut off. Light the string and in burning the string it heats the bottle neck. When the fire is burned out, simply plunge the bottle into cold water and then tap the bottle lightly and your insulator will fall right off, cut neatly where you tied your string. I have made as many as ten of these in as many minutes and they are as efficient as those that are purchased.—B. P. Craig, Youngstown, Ohio.

Turns of Wire Per Inch

In the construction of single or double slide tuning coils, No. 18 enameled wire is commonly used, while for couplers and variometers either No. 22 or No. 24 double silk or cotton covered wire will give satisfactory results. The number of turns per inch are as follows:

No. 18 enameled, 23 turns; No. 22 double cotton covered, 28 turns; double silk covered, 32 turns; No. 24 double cotton covered, 33 turns; double silk covered, 39 turns.

Atlantic City is considering installation of loud speakers along the famous boardwalk, so that strollers can hear addresses by prominent men, baseball scores, and other entertainment as they promenade.

HOOK-UP BLUE PRINTS WITH ALL PARTS' VALUES GIVEN FOR—

- 1—Hazeltine Neutrodyne
 - 2—Gibbons Ultra Audion
 - 3—Cockaday Four-Circuit
 - 4—Single Tube Reflex
 - 5—Three Tube Reflex
 - 6—Fluwellling Filter
 - 7—Armstrong Super Regenerative
 - 8—Armstrong Super Heterodyne
 - 9—New Ultra Rehnartz
 - 10—Kaufman Circuit
- These helpful prints designed by a Member of the Institute of Radio Engineers. All ten mailed prepaid for five dollars (\$5) or single prints at 75c apiece. Send money order or check (no stamps).

HOME WORKSHOP CO., P.O. Box 1062, CHICAGO

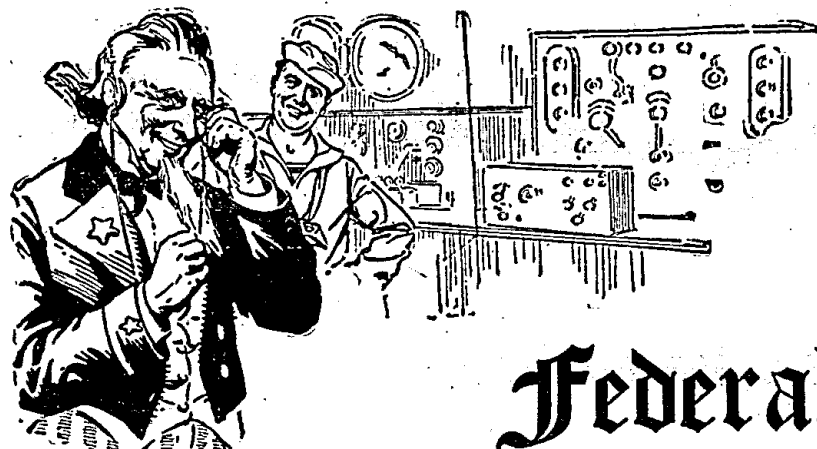

Federal Standard

Radio Head Sets

When you buy Federal Head Sets you obtain the lasting satisfaction that comes with Radio equipment universally endorsed by engineers and experts.

Years of experience in making communication apparatus enabled Federal to enter the Radio field with Head Sets and other Radio apparatus unsurpassed for efficiency in operation.

Permanent magnets, specially treated steel, and precision machining of metal parts are some of the outstanding features of construction that make Federal Standard Head Sets the best you can buy.

Federal Standard Head Sets are made with 2200 Ohms and 3200 Ohms resistance.

Federal makes a complete line of Standard Radio apparatus—all reasonably priced. Write for latest catalog.

Ask your dealer for Federal Standard Head Sets. If out of stock he can get them from our nearest office.

Accept no substitute.

Federal Telephone & Telegraph Company

Oldest and largest manufacturers of a complete line of Radio Equipment

Factory: BUFFALO, N. Y.

Western District Office: 417 South Dearborn St., Chicago, Ill.

How to Make a Camper's Portable Reflex Set

Part II—Three New Reflex Circuits

By H. J. Marx

UNDoubtedly a very small loop aerial with a condenser for the tuning element requires considerable Radio frequency amplification in order to properly build up the grid potential necessary for satisfactory detection and reception. This means that at least two tubes will be required, and, in order to save space, maximum possible results should be planned from these tubes. This naturally suggests the use of reflex circuits.

Since the apparatus required for these circuits should necessarily be of the best quality, the cost rapidly climbs. In order to permit the fan to adjust the cost of his set to balance with the Radio budget that his finances call for, three different forms of the same circuit are presented.

Portable reflex No. 1 is a two tube circuit equivalent to two stages of Radio frequency, detector and one stage of audio frequency.

Portable Reflex No. 2 is a three tube circuit equivalent to three stages of Radio frequency, detector and two stages of audio frequency.

Portable Reflex No. 3 is a four tube circuit equivalent to three stages of Radio frequency, detector and three stages of audio frequency. The last stage of audio frequency is not reflexed and a jack is added so that the phones or a loud speaker can be plugged in after the second stage of audio frequency.

Development of these Circuits.

Some interesting experiences were encountered in the development of these circuits. Although potentiometers are more

and the secondary of the audio frequency transformer.

This solved that difficulty. In order to get maximum efficiency the internal capacity of the variometers should be very low, and for this reason the lattice wound type are preferred.

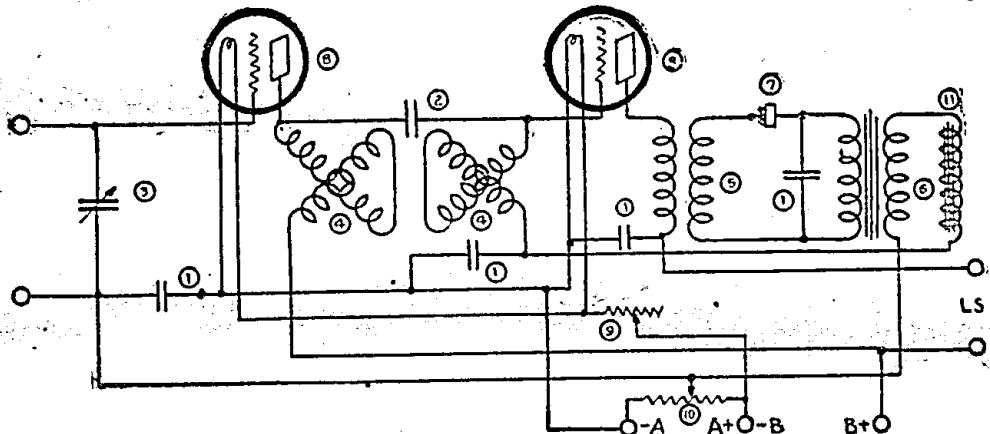

Figure 1

or less satisfactory for controlling the grid potential of the tubes, still there was something lacking when used to control the reflexing of the audio frequency currents back into the tubes the second time. Another noticeable disadvantage was the fact that when these audio frequency impulses were reflexed back into the grid circuits, passing them through the secondary windings of the Radio frequency transformers developed a decided loss in potential variation.

Identification of Apparatus

In order to identify the parts used in the three hook-ups—the various parts in the diagram can be identified by the numbers in the circles next to them. The lists of parts with the numbers for the different circuits are given.

Portable Reflex No. 1

No. 1—.002 mfd. fixed condenser (4 required); No. 2—.00025 mfd. fixed condenser; No. 3—.0005 mfd. variable condenser with vernier; No. 4—Lattice wound type

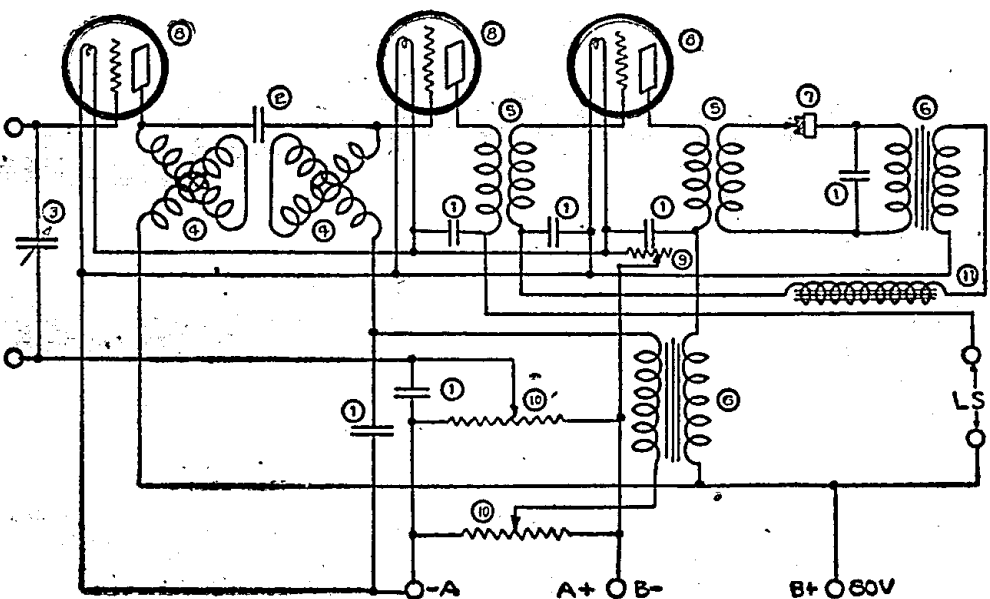

Figure 2

For this reason the variometer type of Radio frequency coupling was employed between the first and second tubes. The reflexed impulses were then tapped into the grid circuit between the condenser and grid. If three tubes or more are employed only one stage is coupled in this manner and the first stage of reflexed audio frequency followed the usual transformer coupling practice. The second stage of audio frequency, however, followed the method just outlined. In order to control the amount of energy fed into this circuit, a variometer is inserted in series as shown in each of circuits illustrated. This, however, introduced some peculiar actions in the circuit operation. There was a choking action that not only effected the modulation but also decreased the volume. This apparently indicated that some form of apparatus was necessary to prevent the Radio frequency impulses from feeding back in and through the variometers. A 100-milhenry iron core choke coil was inserted in series between the variometer

variometers (2 required); No. 5—Radio frequency transformer; No. 6—Audio frequency transformer; No. 7—Crystal detector; No. 8—Amplifier vacuum tubes

Cockaday Circuit TUNER COILS

BC AND D COILS
Complete as per specifications

No. 18 Wire Used—D Coil Bankwound. Price, \$2.75

Hook-up, directions and material list furnished free with each set of coils.

MAIL ORDERS FILLED

Dealers, Communicate

Eastern Radio Mfg. Co.
22 Warren St., Dept. R.D., New York, N.Y.

with sockets (2 required); No. 9—Power rheostat; No. 10—400-ohm potentiometer; No. 11—100 M. H. iron core choke coil; Seven binding posts.

Portable Reflex No. 2

No. 1—.002 mfd. fixed condenser (6 required); No. 2—.00025 mfd. fixed condenser; No. 3—.0005 mfd. variable condenser with vernier; No. 4—Lattice wound type variometers (2 required); No. 5—Radio frequency transformer (2 required); No. 6—Audio frequency transformer (2 required); No. 7—Crystal detector; No. 8—Amplifier vacuum tubes and sockets (3 required); No. 9—Power rheostat; No. 10—400-ohm Potentiometers (2 required); No. 11—100 M. H. iron core choke coil; Seven binding posts.

Portable Reflex No. 3

No. 1—.002 mfd. fixed condensers (6 required); No. 2—.00025 mfd. fixed condensers; No. 3—.0005 mfd. variable condenser with vernier; No. 4—Lattice wound type variometers (2 required); No. 5—Radio frequency transformers (2 required); No. 6—Audio frequency transformers (3 required); No. 7—Crystal detector; No. 8—Amplifier vacuum tubes and sockets (4 required); No. 9—Power rheostat; No. 10—400-ohm Potentiometers (2 required); No. 11—100 M. H. Iron core choke coil; No. 12—Single circuit jack; No. 13—Double circuit jack type battery switch; No. 14—Double circuit jack; No. 15—Rheostat; Five binding posts.

Inasmuch as the tubes used will be dry cell type, to save weight and space, the

tube sockets will require a resilient form of mounting. This will be taken up in the next article in conjunction with the panel layouts. Standard sockets are used throughout, and where necessary adapters can be used.

The choke coil used may be purchased at any good Radio dealer as there are a number of concerns manufacturing them. The variometers must be small in size in order to conserve the necessary space. A special form of very small audio frequency transformer known as the hedgehog type is used in the circuit. This permitted the very compact assembly which will be illustrated later.

(TO BE CONTINUED.)

If you haven't water pipes in your home, a good ground can be made by driving a galvanized pipe four or five feet into moist earth.

GOLD-GRAIN CRYSTAL DETECTORS

DEALERS—New List Attractive Discounts

HUDSON-ROSS
123 W. Madison St. Chicago

Money Earning Opportunity

HERE is your chance to cash in on your spare time. A special offer is being made to you for the summer.

YOU can easily earn some real money, or your choice of Radio parts needed for your receiving set.

WORK is pleasant and profitable. Just call on your friends, enrolling their names on our large family roll of readers.

WRITE at once for our proposition which is yours for the asking. Address

Circulation Manager, Radio Digest
123 W. Madison St., Chicago



"NACIREMAN" LATEST EASY SUPER HOOK-UP

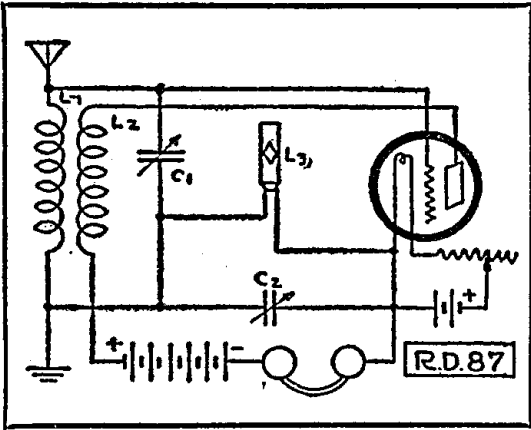

HOOK-UP R.D.-87 is a new single-tube receiving circuit, known as the Nacireman. This circuit was developed in the laboratories of Wired Radio, Inc., during a series of experiments with a large number of receiving circuits. This new circuit is not suitable for wired Radio because of its tendency to re-radiate, but it is probably the last word in a simplified single tube set for receiving news and music from the present broadcasting stations.

Parts Required

- 1 Variometer or Variocoupler. L1 is the rotor winding. L2 is the stationary winding.
- 2 23-plate condensers, preferably with verniers (C1 and C2).
- 1 750-turn DL or honeycomb coil or its equivalent (L3).
- 1 Tube, WD-11, UV-201A, or other hard tube.
- 1 Tube socket.
- 1 Filament rheostat (R).
- 1 A battery, 1½ to 2-volt for WD-11 tube; 6-volt for other tubes.
- 1 B battery, 45 to 90 volts for WD-11; 45 to 135 volts for other tubes.
- 1 Pair phones.

The circuit is being published with full details in the interests of amateurs and the public who may wish to listen to the programs now in the air. The set is super-regenerative and full credit should be given to E. H. Armstrong for the discovery of this principle, of which this may be considered an extremely simplified form. The circuit requires a minimum investment in parts. Practically every amateur already has everything necessary to try out the circuit. It will be noted that all resistances, grid leaks and grid condensers have been eliminated and no filter circuits are required. Any amateur can connect up one of these sets in an hour or two and the results will surprise the most hardened Radiophan.

Almost any metallic structure which may be picking up Radio waves may be used as an aerial. Connection to a bed spring, wire window screen, steam radiator or fire escape is often all that is necessary. A short overhead aerial, a length of wire strung across the room, concealed behind the picture moulding or under the carpet, will also serve.

Tuning is accomplished by rotating the movable coil of the variometer or variocoupler until the tube oscillates. Then adjust condenser No. 1 until the station desired is heard, finally adjusting con-

Kellogg Radio Equipment For Better Results

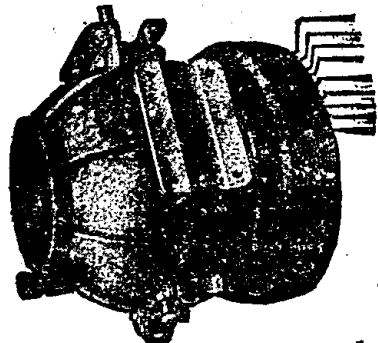

VARIOCOUPLER

The Kellogg variocoupler is of the same standard design as our variometer, being made of molded Bakelite, with reinforced construction.

For increasing the wave length from 500 to 2,500 meters, the Kellogg standard wound induction is added to the variocoupler.

It is arranged for either panel or base mounting. No. 501 Variocoupler \$9.00
With No. 502 Diamond Wound Coil, as shown in illustration. \$13.00

Kellogg Switchboard & Supply Company
CHICAGO

denser No. 2 to the frequency of oscillation which brings in clear speech and music. A second fine adjustment all around will increase the volume and some regulation may be secured with the filament rheostat.

FIRST STEPS IN RADIO

(Continued from page 11)

quite a change in the grid voltage affects the plate current very little, but near the center of the curve a slight change in grid potential results in an appreciable change in the plate current and therein lies the secret of the vacuum tube as an efficient detector.

Function of Tube in Circuit.

Now let us consider how the tube functions when connected in a Radio circuit as a plain detector. The usual circuit is shown in Figure 34, which shows a variable condenser in the grid circuit with a grid leak connected across it.

If no Radio signals are acting upon the tube a steady current will flow from the plate to the filament and back through the phones depending upon the voltage of the plate and the temperature of the filament. When an incoming signal acts upon the inductance a current will flow in the grid circuit. When the direction of this flow is such as to put a positive potential on the grid, some of the electrons from the filament will be attracted to the grid, but when the potential is reversed, the electrons on the grid cannot escape being held there by the blocking condenser in the grid circuit. On the next reversal more electrons are attracted to the grid and hence at each oscillation the negative charge on the grid is built up to such a value that it repels the electrons from the filament and thus interrupts the plate current, causing a sound in the receivers.

Were the grid completely insulated from the rest of the circuit by the dielectric in the condenser, the negative charge thereon would constantly increase till it shut off the plate current completely and the tube would "block" or cease to function. However, a leak is connected across the condenser as shown and allows the charge to leak off slowly. The effect of this leak then is to prevent the condenser holding too much charge on the grid but should not be so small as to permit too much of the charge to escape quickly. Then by experimenting, the proper value of a leak is determined that will permit the potential of the condenser to rise and fall with the amplitude of the incoming waves and the varying negative charges on the grid thereby vary the plate current to reproduce the audio frequency waves impressed on the carrier wave at the transmitting station.

Changes in Grid Potential.

The curve in Figure 33 shows that it is to an advantage to work on the middle part of the curve so that slight changes in the grid potential will cause greater variations in the plate current and thus produce the loudest signals in the phones. It should be remembered that it is simply the amount of change in the plate current that gives the signals and not the amount of current flowing. To this end it is advisable to either regulate the constant potential of the grid or shift the curve by varying the plate voltage or filament tempera-

AMPERITE
AUTOMATIC FILAMENT CURRENT ADJUSTER FOR EVERY STANDARD TUBE
ELIMINATES RHEOSTATS
EXPELS ALL TUBE TROUBLES
FROM YOUR DEALER OR RADIALCO COMPANY \$1.10 WITH MOUNTING

Coast to Coast on One Tube, and No Body Capacity

These popular hook ups use U. V. 199, W. D. 11 or W. D. 12 tubes. One hook up gives selectivity and 1500 miles with absolutely no body capacity, while the other gives the remarkable distance of coast to coast. Both prints post paid for 50 cents or any of the above tubes post paid \$5.75.

C. W. KAUTZ, Box 362 LANCASTER, PA.

"MAKE PERFECTION YOUR SELECTION"

We Carry Only STANDARD Advertised Radio Equipment. Every Product Sold on a MONEY BACK GUARANTEE.

MAGNAVOX \$24.95
LOUD SPEAKER, Type R. 3.....

N. & K. PHONES \$6.50
6000 Ohms. None Better Made for DX Reception. Imported. List \$16.00

"B" BATTERIES	List Price	Our Price
EVEREADY—No. 763—22½ Volts.....	\$1.75	\$1.45
EVEREADY—No. 767—45 Volts.....	5.50	4.50
BRIGHT STAR—No. 15-50—22½ V.	1.75	1.10
BRIGHT STAR—No. 15-03-6—22½ V.	2.25	1.45
BRIGHT STAR—No. 30-90—45 Volts.....	5.00	3.50
FRANCO—No. 1529V—22½ Volts.....	2.50	1.85
FRANCO—No. 3045V—45 Volts.....	5.75	3.95

CABINETS	
Extra fine quality—Hinged top—Mahogany finish.	
7x10	\$2.75
7x12	2.95
7x14	3.25
7x18	4.50
7x24	5.75

VT-2 TUBES—Genuine Western Electric Tubes THE BEST AMPLIFYING TUBES MADE \$7.95

PERFECTION RADIO CORPORATION, 59 Cortland St., NEW YORK CITY
Add parcel post. Do not send stamps.

ture. Shifting the curve, as it is called, simply means that by varying the plate voltage the curve is moved to the right or left of the center line of the grid voltage. So with a fixed grid potential a change in voltage enables us to shift the steep part of the curve to suit that particular grid potential. That is the reason for variable B batteries for detector tubes.

Although not the usual practice, the highest efficiency is obtained from a tube detector when the grid condenser is made variable so that the potential of the condenser itself can be controlled. Those desiring the best results with tubes should use a small variable air condenser in the grid and use the best leak obtainable.

Harassness of Tubes.

The main difference between a detector tube and the amplifier tubes is their "hardness." A hard tube is one that has been pumped to a high vacuum; the soft tubes contain a very small amount of gas. A soft tube functions best as a detector for the following reason: When a slight amount of gas is present, the electrons emitted by the filament strike the molecules of gas and break them up into their electrical components and the gas is said to be ionized, that is, split up into ions, negative and positive. In this state the gas is conductive and a large plate current is obtainable with a low plate voltage. With the low plate voltage the attraction of the plate for the negative electrons is naturally lower and the smallest change in grid potential will affect the electronic stream.

On the other hand, the hard tube functions best as an amplifier because higher voltages can be impressed on the plate and since the grid potential changes are greater in the amplifier stages by reason of the step-up effect in the detector, the grid can control the heavy electron stream with the high plate voltage. A high voltage cannot be used on the detector because it would exert too much attraction on the electrons and small grid charges would not deflect them. Also, when the gas in a soft tube is ionized, a high plate voltage would force too heavy a current through the tube and it would give a blue glow and spill over.

We can see now that the function of the vacuum tube is to act as a sort of relay by means of which the weak incoming signal is made to control a local source of current and vary its intensity in accordance with the modulation impressed upon the incoming waves. The crystal detector uses only the received current to actuate the telephone receiver, while the vacuum tube controls current furnished by batteries to give louder signals.

In the next chapter we will see how this local battery can be made to react on the grid circuit of the tube to give regenerative effects and great signal strength.

The Reader's View

Calming Set

In your issue of March 10th there appeared a hook-up with an addition of two .001 mica condensers to prevent howling in a set. I have an Armstrong regenerative set with two stages of amplification and a Pathe loud speaker. I tried the condensers as shown and will say that they certainly calmed my set down as to whistles and cracks and do not diminish the volume of sound, as I have been unable to get stations WJZ or WOR without a whistle or howl—thanks to Mr. Joe McCormack of Godsen, Ala.

Am using 112 volts on the plate and every sound of voice or music is quite plain. I hope this compliment will be brought to the eyes of Mr. McCormack. —James Nolan, Jersey City, N. J.

P. S.—I have shown your magazine to quite a number of my friends, and I think your circulation will be increased in this section.

Amplifying Crystal Set

One or two stages of amplification may be added to a crystal receiver with good results, but if this installation is contemplated it is advisable to also use a vacuum tube to replace the crystal detector, as batteries for filament heating and plate voltage must be provided for the amplifying stages and are therefore available for use with a detector tube. Sometimes, however, the crystal detector is advisable to give clearer and less distorted reception.

WE REPAIR YOUR VACUUM TUBES

- WD-11, WD-12, UV-199, UV-201-A, C-301-A.....\$3.50 each
- UV-200, C-300, AP Detectors..... 2.75 each
- UV-201, C-301, AP Amplifiers..... 3.00 each
- DV-6, DV-6-A..... 3.50 each
- UV-202..... 4.00 each

And Guarantees Them Equal to New
QUICK SERVICE Include with your order remittance to cover repair plus parcel postage for one pound per tube. If preferred, tubes will be returned C.O.D. repair charges.

Abalene Radio 14 Vesey Street New York, N.Y.

How to Make a Reinartz Receiver

Complete BLUE PRINTS

for the construction of a Reinartz Receiving Unit and two step amplifier.

INSTRUCTIONS FOR ASSEMBLY
Description of apparatus and accessories and details of tuning.

WINDING A REINARTZ COIL
Cabinet Dimensions
Panel Layouts
List of Parts

Send only money orders—no checks or stamps. Coins at your own risk.

Book Department
Radio Digest
123 West Madison Street CHICAGO, ILL.

only 50¢

Questions and Answers

Pretty Good So Far

(2587) TB, Jefferson, Iowa.
I have built a Flewelling circuit and I am having nearly the desired results. Get a great many stations from far and near. Los Angeles to Atlanta-Schenectady, New Orleans to Regina, Sask., etc. All told over 100 stations.

Will say that she is sure a winner and believe I am far from possible results due to the fact that I am not fully acquainted with set. There are a few changes in wiring that I will work out in time.

The writer has adhered to the blue print and instructions purchased of the Radio Digest with one exception and therefore this letter.

In the detector circuit I am unable to use the wire connecting the phone condenser with the fixed grid leak of 1/2 meg. Without the above connection I have heard many stations.

When same connection is made it kills reception, and I hear a noise of frying and cracking like B battery or static. It seems like the B plus goes through the primary on transformer of first stage and through to condenser bank and negative A.

Wouldn't bother you with such fool stuff if I wasn't desirous of making this set step out to beat a friend who has a two variometer set which is best I ever heard. I believe I am equal to him now and just need that little something to get E. T. Flewelling results.

A.—Noting your splendid success and enthusiasm with results afforded with the Flewelling circuit we are delighted to congratulate you.

Noting the difficulty encountered it is indicated either that grid leak or one of the condensers in your bank is shorted. Would advise substituting another grid leak. A pencil line grid leak will serve. If no better results accrue, try another .006 condenser in place of the one which is across the grid leak. In our opinion one or the other of these details will solve your difficulty. It is difficult to determine without a personal inspection, but we believe it can be safely left to your skill to overcome the condition prevailing.

Three Transmitting Circuits

(3651) CK, Jefferson City, Mo.
What will I need to do in order to secure

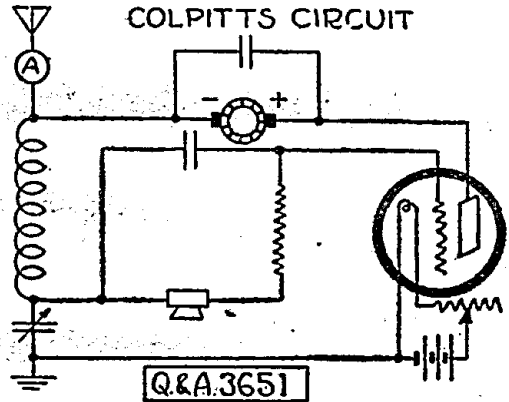

a broadcasting license for a 5-watt transmitting set for experimental use?
Send me a few good hookups for a 5-



Carter "Tu-Way" Plug
Takes 1 to 4 head sets and all types tip terminals; no tools necessary. New list price, \$1.00.
Write for Bulletin on the Carter Line of Products
CARTER RADIO COMPANY, 209 South State Street, CHICAGO

FORMICA

A Laminated Phenolic Condensation Product
SHEETS TUBES RODS
RADIO PANELS
POLISHED BLACK FINISH

CUT PERFECTLY SQUARE TO ANY SIZE

1/32" THICK	1/2¢ PER SQ. INCH
1/16" THICK	3/4¢ PER SQ. INCH
3/32" THICK	1¢ PER SQ. INCH
1/8" THICK	1 1/2¢ PER SQ. INCH
3/16" THICK	2¢ PER SQ. INCH
1/4" THICK	2 1/2¢ PER SQ. INCH
3/8" THICK	4¢ PER SQ. INCH
1/2" THICK	5 1/4¢ PER SQ. INCH

SEND FOR COMPLETE PRICE LIST
PROMPT ATTENTION TO MAIL ORDERS
DEALERS PRICES ON APPLICATION

STARRETT MFG. CO.
519 SOUTH GREEN ST. CHICAGO

watt transmitting set. State what is necessary for the output.

A.—Answering your inquiry with relation to regulations governing broadcasting we are referring you to the United States Radio Inspector, 629 Federal Building, Chicago. Operator of such a station is required to hold a commercial operator's license.

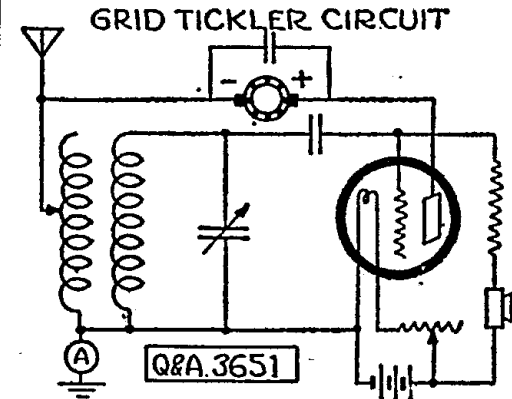

For experimental station an amateur's license is necessary, for which examination is required to qualify.

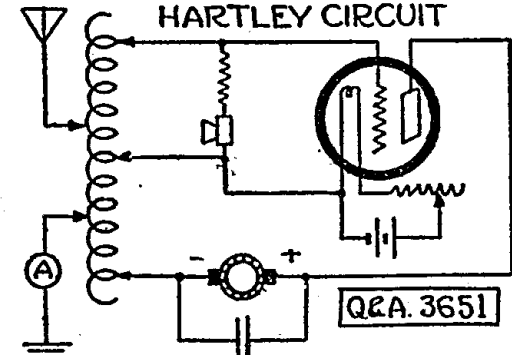

We are giving three diagrams of effective circuits for five watt set, either phone or telegraph.

Super Regeneration

(2408) WHC, Chicago, Ill.
At present I am operating a standard regenerative double variometer hook-up with one stage of audio amplification, using W. D. 11 tubes and I am getting splendid results, often getting Ft. Worth, Texas, and all the Eastern and Southern stations. However, I would like to know

REFLEX
Erla Reflex Transformers
DEALERS: SEND FOR LITERATURE
HUDSON-ROSS
123 W. Madison St. Chicago

if it would not be possible to make my set super-regenerative along the line of the Flewelling circuit. Would it be possible to hook in somewhere between the plate variometer and the grid variometer and the filament circuit, the proper condenser trap as shown in the Flewelling super circuit. Would it not be a good thing to ask Mr. Flewelling if this could be done? If it could be done, it would be a great boon to a lot of us Radio fans, as then we could convert our present circuits to that of the super regenerative class.

Do you think it could be worked out? Otherwise, I will be tempted to make a straight Flewelling circuit.

I would like also to ask your Radio expert which of the two circuits does he consider the most sensitive circuit, the one that is conductively arranged or one inductively arranged? My present double variometer circuit is an inductive circuit, there being absolutely no metallic connection between the primary or aerial ground circuit and the tube and plate circuit. However, I understand that the Aerola, Sr., is a conductive circuit, there being a direct connection between the grid and the aerial and ground. What I would like to know is, which is the most sensitive of these two circuits? I have always had an idea that the conductive circuit is more sensitive, but will not tune as close or fine and is more subject to interference from spark stations than the other one. Can you set me right?

A.—Noting your scheme for introducing super-regeneration in your present circuit will advise that this has been tried out in the manner suggested but has not afforded the results that might have been expected.

If it is volume that you desire to attain, why not add more amplification, rather than use any other circuit?

There is practically no difference in results attained through conductive and inductive coupling, although theory would have the single circuit to be the most efficient. However, on two sets, one of each type, working at the same time there is no

difference noticeable. (Presuming, of course, that their only difference lies in tuning inductance.) The single circuit is not at all selective and it is difficult to keep separate broadcasting stations from interfering, and as for spark signals it is quite impossible to cut them out with any but a two circuit tuner such as you are using.

Homemade Tuner

(2850) RCV, West End, Ala.

As a beginner in Radio I wrapped 70 turns of No. 20 cotton covered copper wire around a cardboard tube 7 inches long and 3 1/2 inches in diameter, making several connections. This was a double-slide tuning coil employing a crystal detector. Having had fine results with it, hearing WEA, New York City, I wanted a nice set. I took much care this time, first winding the coil of No. 22 d.c.c. and then trying No. 22 enameled copper wire. Neither set was near as loud as the first and could not do any out of town receiving. What is my trouble?

A.—Noting your specifications and conditions encountered, and presuming that your coil was wound the same as in the first attempt, we venture the opinion that in changing your crystal detector from one set to the other you have in some way destroyed its sensitivity. It is difficult to determine conclusively just where the trouble may lie without inspection of each set.

PHANTOM-CIRCUIT

Build Your Own. This marvel of mystery, using no loop, no aerial and no ground, brings in music instead of interference. We have heard stations 950 miles distant on one tube. By using WD-11 tube set can be entirely self contained. Very easy to build from our instructions, use your own spare parts, nothing complicated like radio frequency or super regenerative. Only one tuning control. Complete instructions, with hookup and photo of circuit mailed to you for 60 cents. Stamps accepted.
VESCO RADIO SHOP, Box D-704, Vacaville, Calif.

TWO SUPERSENSITIVE CIRCUITS

(Both Copyrighted)

My Highly Improved Reinartz brings in all important stations on both coasts and Mexican border, loud, clear and without distortion. We dance to music from Atlanta received on one loud Baldwin unit. Build one of these wonderful sets from my blueprints and specifications, price 50c, or with a perfect and complete double wound spiderweb coil, \$3.00 by mail. No other windings used. Photo of my set on a glass panel with every order.

This copyrighted circuit is the most successful of any Reinartz modification yet produced, and is imitated the most. Thousands are in use.

My W. D. 11 Circuit is especially designed for use with the "Pickle" tube and brings out the full value of that little tube as no other circuit can. Stations 1000 miles away come in clearly on one tube. This set is small, complete, portable. For the man who wishes the highest efficiency, this is the set to build. Price of blueprint and specifications, 50c, or with complete and perfect windings, \$3.00. Photo of set with every order.

Either set is easy to build, easy to operate. Everything clear. Sets built from these plans will receive all broadcasting stations operating under the new laws. Their wave length range is from 140 to 670 meters.
S. A. TWITCHELL
1925 Western Ave. Minneapolis, Minn.

WILLARD RADIO COMPANY

291 Broadway "The Best for Less" New York City

FLEWELLING CIRCUIT
Every part complete, including drilled panel and book of diagrams and instructions **\$11.95**

REINARTZ CIRCUIT
Every part complete, including drilled panel and book of diagrams and instructions **\$10.95**

Two-stage Audio-Frequency Amplifier. Every part complete for above circuits at **\$11.00**

A Recommendation

Hartford, Conn., June 4th, 1923.

Willard Radio Co.
New York City.
Dear Sirs:—

I received the Flewelling Circuit complete and wish to thank you. It is a beauty. I set it up in one hour and a half, but I have to get batteries so I wish to thank you again, also for the present that you sent me.

I have priced the machines here in Hartford and find that they cost anywhere from \$35 to \$180. I do not see how you can sell them so cheap.

I will close now but if I want anything in the future, you will have my order.

Again I wish to thank you.
I remain

Yours truly,
CHAS. W. HIGLEY.

147 Babcock St.,
Hartford, Conn.

CONDENSERS

3 Plate Variable; value, 1.75.....	\$1.05
13 Plate Variable; value, 2.50.....	1.20
23 Plate Variable; value, 3.50.....	1.35
43 Plate Variable; value, 4.50.....	1.95
13 Plate Vernier; value, 5.50.....	3.75
23 Plate Vernier; value, 6.00.....	4.00
43 Plate Vernier; value, 6.50.....	4.25

Honeycomb Coils, 50 turns mounted.....	.95
Honeycomb Coils, 75 turns mounted.....	1.00
Double Coil Mountings.....	2.45
Triple Coil Mountings.....	3.35
Reinartz Coil increased wavelength, and mounting.....	1.75
Jacks, Single Circuit; value, 65c, special at.....	.30
Double Circuit; value, 90c; special at.....	.45
Multiple Point Inductance Switch with Knob and Dial (15 Switch Points).....	1.45
Lightning Arresters, approved, heat resisting.....	.90
Three-inch Dials, unbreakable, heat resisting composition, high finish; special.....	.30
Two-inch Dials, same design, for rheostats and potentiometer; special at.....	.25
Aluminum Loud Speaking Horn, nickel plated, highly polished; \$8.00 list.....	3.75
Filament Rheostat, 6 ohm.....	.65
Filament Rheostat, 20 ohm.....	.80
Filament Rheostat, 50 ohm.....	.90
With 2" Dial, 15c extra.	

A beautiful "SALRITE" pencil FREE with every order of \$12.50 or more. Made of beautiful Mahogany Rubber—five inches long. Equipped with vest-pocket clip, 10 leads and eraser.

Now is the time to build your own set to take with you on your vacation. We will be glad to offer you any information or advice that you may require. Just drop us a line.

Every article advertised above is guaranteed by the manufacturer and by us. Mail orders filled immediately. Transportation PREPAID on all orders of \$5.00 or over, east of the Mississippi River. All others include postage.

Your Choice

Radio Digest
Illustrated
BOUND VOLUMES
Numbers
Two, Three or Four
Postpaid by Parcel Post
with One Year's Subscription to Radio Digest
Greatest Collection of Radio Information Ever Published
Reinartz Long Distance Circuit; Ultra-Reinartz Circuit; Flewelling "Fliver" Circuit; Grimes "Inverse Duplex" Circuit; Single Tube Reflex Circuit; Armstrong "Super-Heterodyne" Circuit; Two, Three and Four Tube Reflex Circuits. On account of the limited supply, the sale of these volumes is limited strictly to those readers who have subscribed for a year. One year subscription to Radio Digest and both bound volumes 2 and 3 or 3 and 4 or 4 and 2, \$7.00.

One year subscription to Radio Digest and bound volumes 2, 3 and 4, \$9.00. ALL ORDERS MUST BE SENT DIRECT—No orders on this offer will be accepted through subscription agencies, news dealers or other sources. Check, money or express orders (no stamps) must accompany all orders. Two, Three and Four Parcel Post Prepaid. Each, only \$2.00. 13 Numbers in the Bound Volume—52 Numbers in Year's Subscription

65 Numbers

COUPON
PUBLISHER, RADIO DIGEST,
123 West Madison St., Chicago, Illinois.
Please reserve me Bound Volume Number Two and also Number Three, and one year's subscription to the Radio Digest, for which I am enclosing check—M. O. for Seven Dollars.
Please reserve me Bound Volume Number Two or Three or Four and one year's subscription to the Radio Digest, for which I am enclosing check—M. O. for Five Dollars.

Name.....
Address.....
City..... State.....

Radio Illustrated

Radio is being introduced into the "four hundred" as witnessed by this photo of Miss Margaret Hennessy, of New York City, as she tries out a portable set, using a small loop antenna. The outfit was to be raffled off for the benefit of the crippled kiddies at the Park Avenue Street Fair, one of the prominent outdoor affairs of New York society © K. & H.

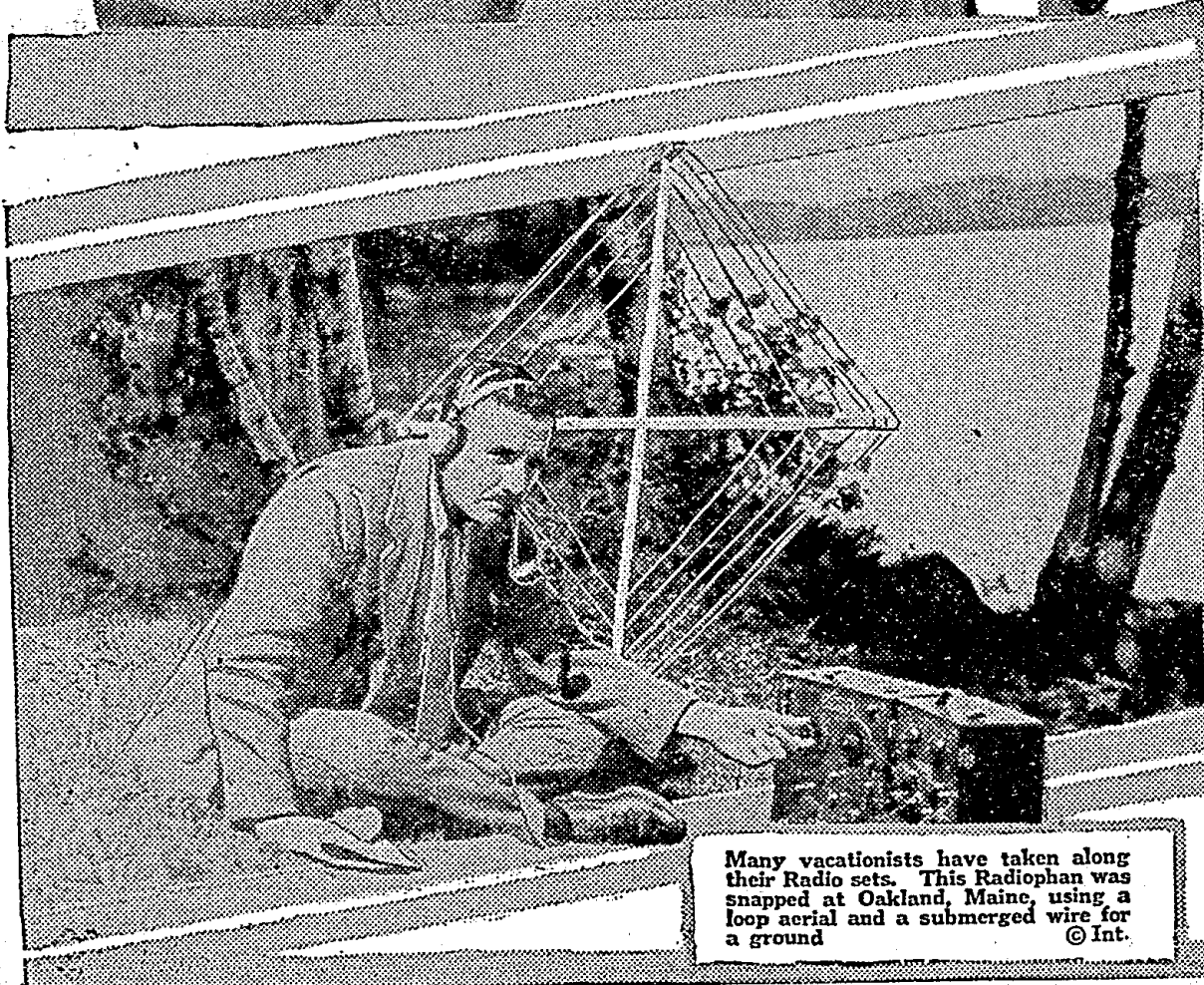

Many vacationists have taken along their Radio sets. This Radiophan was snapped at Oakland, Maine, using a loop aerial and a submerged wire for a ground © Int.



Lord Curzon, foreign secretary of Great Britain, broadcasting a speech recently from his house in Carlton House Terrace on behalf of the great ball which is being held at Lansdowne House for the benefit of the Queen Victoria Jubilee Institution for Nurses © Int.