

# Radio Illustrated

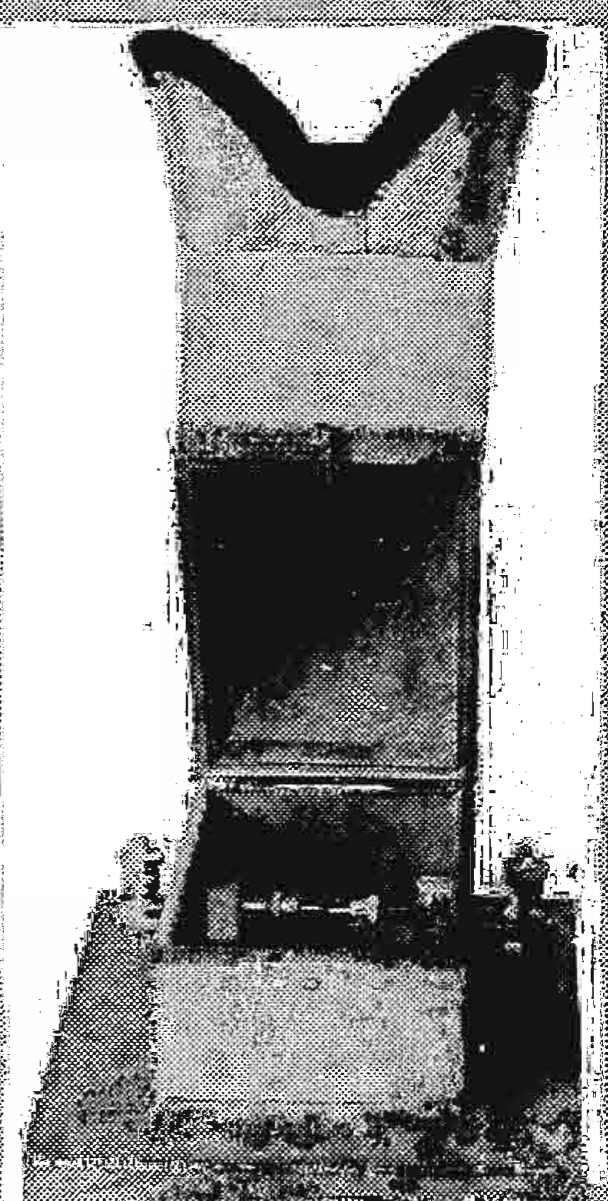

This piece of apparatus should be as much of interest to Radiophans as the old electric incandescent globe or the first street car that stands in front of the Edison plant is to the average individual. The mysterious "black box," as it is called, is another of Edison's inventions in the laboratory in which he discovered the Radio spark of today © K. & H.

The woods are beginning to be filled with music these days. Permanent camps, lodges, tents and even in the open may be found the familiar receiving set and entertainment fresh from the city may be turned loose through the mystery box. It is soothing and relaxing for the vacationist © Wide World

Who is the most ardent baseball fan? Did you ever peek through a knot hole when there was not enough coins in your pocket to pay entrance fee to see a game? Well, that is the boy. Radio helps the boy out of his dilemma. This is a baseball club listening in on the returns from the big leaguers © K. & H.



An ideal way to spend a hot afternoon at the beach, providing you have a canoe and a portable Radio receiving set © U. & U.

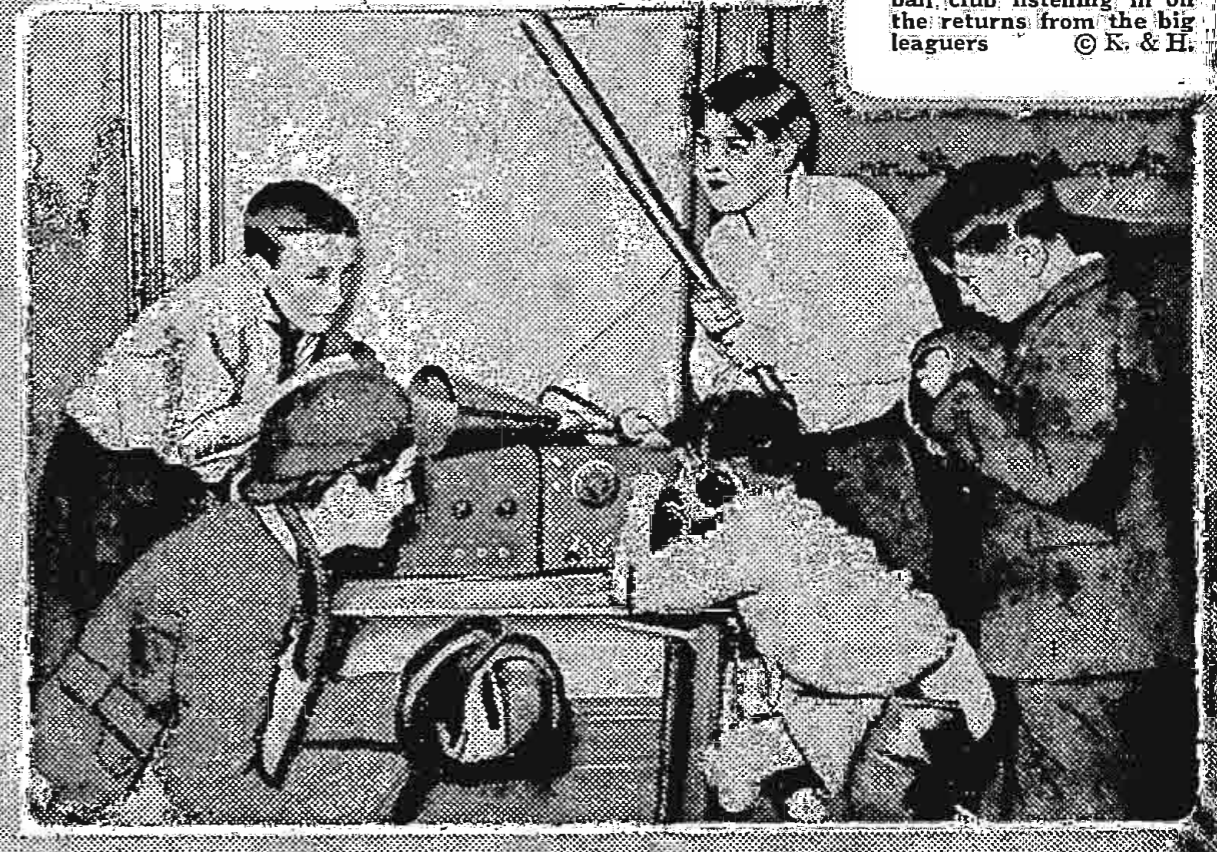

One Tube Reflex; 215A Tube Data; 23 Programs

# Radio Digest

EVERY WEEK **Illustrated** TEN CENTS

REG. U. S. PAT. OFF. & DOM. OF CANADA

Vol. VI Copyright, 1923 R. D. P. Co. Inc. SATURDAY, JULY 21, 1923 No. 2

## MYSTERY WAVES FAKED



Nellie Breen, dancer in the "Passing Show," Apollo Theater, Chicago, takes her portable set to Wilson Beach with her and stays in the shade, because sunburn doesn't mix with musical comedy  
© Radio Digest

### WDAP OPENS AFTER EXTENSIVE CHANGES

#### NEW ANTENNA SYSTEM IS IMPORTANT FEATURE

All Leads from Transmitter Are Laid in Conduits, Out of Way—Counterpoise Covers Roof

CHICAGO.—WDAP, broadcasting station of the Chicago Board of Trade, recently reopened its plant after being shut down for alterations.

While the station has been inactive many changes have been made for the betterment of its broadcasts. The most notable of the changes effected are in the transmitting equipment and antenna with a view towards making the station more powerful. The antenna system now consists of four bird cage aerials radiating from a central mast on the roof of the hotel. A counterpoise, spreading out from the foot of the central mast, covers the entire roof of the building and looks very much like the ribs of a huge umbrella.

In the operating room all of the wiring has been laid in conduits which take the wires out of sight and also prevents the chances of accidents due to contact with the high power leads.

After the program was completed, an exceptionally fine one in the opinion of Radiophans, a reception was given prominent local Radio men in the studio. The general opinion of these gentlemen is that the efficiency of the equipment of WDAP has been greatly increased.

### NO 'STOPPING' WAVES COME FROM NAUEN

"Reports Are Nonsense"

Dr. A. Meissner, German Scientist, Brands Auto Halting Reports as Foolish

(By T. C. Deutschman, Special Correspondent)

BERLIN, GERMANY.—"These reports are foolish, utterly stupid and nonsense!" declared Dr. A. Meissner in an interview here when asked regarding the reported secret waves with which Station POZ, better known as Nauen, is alleged to have been experimenting recently. Many American newspapers have been carrying reports telling how automobiles have been stopped and French airplanes forced to land as a result of the radiation of these waves.

Dr. Meissner is probably the greatest authority in Radio in Germany, and besides being a Radio inventor of international import, is chief engineer for the Telefunken Company, the commercial Radio communication company here. No scientist can doubt the word of the Doctor when he says, "Nauen made no such experiments."

(Continued on page 2)

### WAVES CARRY MUSIC TO 12 DETROIT PARKS

City Installs Sets to Save on Summer Concerts

DETROIT.—The Detroit Department of Parks and Boulevards has selected twelve city parks as locations for Radio band concerts for the summer. WWJ, the Detroit News station, has placed its equipment at the disposal of Scheman's concert band for the public entertainments. About \$500 will be spent by the city for equipment and an operator engaged for each of the parks.

It is found by using Radio the city will save a large sum of money during the summer hiring park bands.

### Nation Listens In to "Biggest Band"

WJAX Broadcasts Music by Massed Grotto Musicians at Cleveland

CLEVELAND, O.—Music, real music, by what is said to have been the biggest band ever assembled for a Radio concert, was broadcast under the auspices of the Cleveland News recently by WJAX, the powerful station of the Union Trust Company here. Keokuk, Ia.; Oshkosh, Wis.; Kennebuck, Me., and Wetumpka, Ala., heard and knew the Grotto had been in Cleveland.

Alice Brady of movie fame was recently interviewed at the microphone of WOR, Bamberger's of Newark, by Regina Cannon, writer for a weekly motion picture publication



# MANY MORE PARTS PUT ON OFFER LIST

## ENTHUSIASM OVER SPECIAL OFFER AWARD GROWS

Fans Keep Sending in Large Numbers  
of Coupons for Valuable  
Radio Accessories

### SPECIAL REWARD OFFER Coupon Number 8

This Special Reward Coupon  
appears each issue in Radio  
Digest until further notice.  
When sent in, accompanied  
by necessary remittance, ac-  
cording to the rules govern-  
ing same, apparatus can be  
secured. See apparatus list  
and rules of offer below.

Save Me—I Am Valuable

A greater flood of coupons into this  
office is expected with the addition of  
many new and valuable accessories to  
the already long list of parts. Some fans  
have sent in as many as four series for  
various parts needed to construct their  
sets.

Send in as many series as you like, the  
only stipulation being that the coupons  
must be consecutively numbered. The  
coupon numbers do not have to start with  
number one, but may begin with any  
number, just so long as the rest of the  
coupons follow progressively numbered.

There is also no limit to the number of  
coupons which a fan may send in. Just  
select your parts and enclose coupons with  
the necessary cash remittance and the  
parts will be shipped to you immediately  
upon receipt of the letter.

#### Rules to Remember

One point must be emphasized to those contemplating  
taking advantage of the special offer; that is, that  
the coupons turned in for any item must be numbered  
consecutively, as for example, 1, 2, 3, and 4 or 3,  
4, 5 and 6. The number of coupons necessary and  
the cash remittance, of course, depend on the item  
sought by the reader. There is no limit to the  
number of series turned in by any one reader.

Another point to remember is that cash, checks and  
money orders but no postage stamps will be accepted.

To make selection more ample the items have been  
divided into eight classes, each class depending on  
the number of consecutive coupons and amount of cash  
remittance necessary. The eight classes of items follow:

#### Class A Articles

For two consecutively numbered coupons and thirty  
cents (\$0.30) any one of the following articles will be  
sent: 1 Carter Imp Jack and Plug; 1 Carter 15-Ohm  
Resistance Unit; 1 Schindler .00025 mfd. Build-up  
Mica Condenser; 1 Schindler .0005 mfd. Build-up  
Mica Condenser; 1 Schindler .001 mfd. Build-up Mica  
Condenser; 1 Schindler .002 mfd. Build-up Mica Con-  
denser; 1 Schindler .0025 mfd. Build-up Mica Con-  
denser; 1 Martin-Copeland Sta Put Plug; Walnart Stan-  
dard Tube Socket; Walnart UV-199 Socket; Ray-O-Vac  
Dry Battery, 1 1/2 volts; Dubilier Micadons Type 601  
(.0001, .00025, .0005, .001, .002, .0025, .003 or .004  
mfd.); Premier Grid Condenser (.00025 or .0005 mfd.);  
Premier Variable Resistance; 1 Carter 25-ohm Resistance  
Unit; Standard Socket Adapter for Delta Midget Tube;  
Electrad Grid Leak (1, 1.5 and 2 megohms, with clips);  
Amesco 3-inch Dial; Amesco Inductance Switch; Fresh-  
man Micon Condensers, (.00005, .00025, .00035, .0005,  
.001, .0015, .002, .0025, or .003 mfd.); Teleradio V. T.  
Socket; B-Metal Mounted Crystal; Aerovox Lightning  
Switch; Aerovox Series Parallel Switch; Aerovox Con-  
tact Lever.

#### Class B Articles

For four consecutively numbered coupons and sixty  
cents (\$0.60) any one of the following articles will be  
sent: 1 Carter .04 mfd. Special Fixed Condenser; 1  
Carter Jack Switch; 1 Carter Hold-Tite Jack, One  
Spring Open Circuit; 1 Carter Hold-Tite Jack, Two  
Spring Closed Circuit; 1 Carter Hold-Tite Jack, Three  
Spring Filament Control; 1 Carter Hold-Tite Jack,  
Four Spring Closed Circuit; 1 Carter Hold-Tite Jack,  
Five Spring Filament Control; 1 Pudlin Variable Grid  
Leak with .00025 mfd. Condenser; 1 Federal Universal  
Phone Plug; 1 Federal Open Circuit Jack; 1 Federal  
Closed Circuit Jack; 1 Federal Double Circuit Jack; 1  
Martin-Copeland Shur Grip Plug; 1 Martin-Copeland  
WD-11 Socket; 1 Martin-Copeland WD-11 Adapter;  
1 Martin-Copeland UV-199 Socket; 1 Martin-Copeland  
UV-199 Adapter 1 Martin-Copeland Pull Switch; 1  
Martin-Copeland 5-point Inductance Switch; 1 Martin-  
Copeland Variable Grid Leak; 1 Martin-Copeland  
SPST Knife Switch 1 Martin-Copeland SPDT Knife  
Switch; 1 Martin-Copeland DPST Knife Switch; 1  
Martin-Copeland DPDT Knife Switch; Walnart Variable  
Grid Leak; Walnart Inductance Switch; Dubilier Mica-  
dons Type 600 (.0001, .00025, .0005, .001, .002, .0025,  
.003, .004, or .005 mfd.); Dubilier Micadons Type 610  
(.001, .002, .0025, .003, .004, or .005 mfd.); Dubilier Mi-  
cadons Type 601 (.006 mfd.); Dubilier By-Laws Condenser  
(.1, .25, or 5 mfd.); Premier Universal Tube Socket; Pre-  
mier Radio Dial (3/16, 1/4, or 5/16 in. black or white  
face); Premier Universal Radio Jack, Open Circuit; Pre-  
mier Universal Radio Jack, Two-Circuit Three Spring;  
Premier Universal Radio Jack, Two-Circuit Four Spring;  
Premier Universal Radio Jack, Filament Control Three  
Spring; Premier Switch Lever and 10 Points; Turney  
Spider Web Coil (SW-10 with .038 milhenry inductance,  
SW-15 with .066 MH., or SW-20 with .300 MH.);  
Amesco 6-Ohm Rheostat; Freshman Fix-O Grid Leak  
and Condenser; Freshman Variable Resistance Leak  
(with or without condenser); Freshman Micon Con-  
densers (.006 or .005 mfd.); Teleradio 6-Ohm Rheostat;  
Teleradio 30-Ohm Rheostat; Teleradio Lightning Ar-  
rester; B-Metal Crystal Tube Detector Type A; B-Metal  
Adjustable Detector Type D; Aerovox Rheostat.

#### Class C Articles

For six consecutively numbered coupons and ninety  
cents (\$0.90) any one of the following articles will be  
sent: 1 Carter 6-Ohm Vernier Control Rheostat; 1 Carter  
"Tu-Way" Plug; 1 Federal Panel Mount Socket; 1  
Federal 6-Ohm Rheostat; 1 Federal 3-Ohm (Power)  
Rheostat; 1 Amperite Automatic Filament Control (with  
mounting); 1 Martin-Copeland Marco Rheostat; 1  
Martin-Copeland Series Parallel Switch; 1 Martin-Cope-  
land DPDT Panel Switch; 1 Martin-Copeland 7-Point  
Inductance Switch; 1 Martin-Copeland 9-Point Induc-  
tance Switch; 1 Martin-Copeland 11-Point Inductance  
Switch; Walnart Variable Grid Leak with .00025 mfd.

Condenser; Walnart Variable Condenser (3-plate .00066  
mfd.); Ray-O-Vac Dry Battery, 2 cells 1 1/2 volts;  
Dubilier Ducon; Dubilier Micadon Type 600 (.006 mfd.);  
Dubilier Micadon Type 610 (.01 or .02 mfd.); Dubilier  
By-Pass Condenser (1 mfd.); Premier Universal Radio  
Jack, Filament Control Five Spring; CRL Variable Grid  
Leak, without condenser; Premier No. 250 Variable Res-  
istance, panel mounting; Thordarson Vernier Rheostat;  
Ritter Loop Aerial; Martin Copeland Variable Grid  
Leak; Amesco Multiple Point Inductance Switch;  
Amesco 20-Ohm Rheostat; Amesco 50-Ohm Rheostat;  
Freshman Antenna; Freshman Micon Condenser, .01  
mfd.; Teleradio Variable Condensers, (3-plate or 11-  
plate); Set "Read 'EM" Binding Posts (9); B-Metal  
Crystal Tube Detector Type B; Illinois Cushion Resilient  
Socket; Aerovox Antenna Plug; Aerovox Potentiometer;  
Aerovox Crystal Detector.

#### Class D Articles

For eight consecutive coupons and one dollar and  
twenty cents (\$1.20) any one of the following articles  
will be sent: 1 Carter 20-Ohm Vernier Control Rheostat;  
1 Schindler Radio Frequency Transformer; 1 Martin-  
Copeland 13-Point Inductance Switch; 1 Martin-Copeland  
15-Point Inductance Switch; 1 Martin-Copeland 19-  
Point Inductance Switch; Walnart Variable Condenser  
(5-Plate, .0001 mfd.); Ray-O-Vac No. 4151 B Battery,  
2 1/2 volts; Ray-O-Vac Dry Battery, 3 cells 4 1/2 volts;  
Electrad Variom, with mica condenser; Dubilier By-  
Pass Condenser (2 mfd.); CRL Variable Grid Leak  
with Condenser; Resistometer (Type A or 2A); Thordar-  
son Variable Condenser, .00025 mfd.; Amesco 300-Ohm  
Potentiometer; Freshman Micon Condenser, .015 mfd.;  
Teleradio Variable Condenser, 23-plate; Aerovox Crystal  
Detector and Condenser, mounted.

#### Class E Articles

For ten consecutively numbered coupons and one  
dollar and fifty cents (\$1.50) any one of the following  
articles will be sent: 1 Carter 6-Ohm Automatic  
Control Rheostat; 1 Carter 20 Ohm Automatic Control  
Rheostat; 1 Demcal 3-Plate Variable Condenser; Walnart  
Variable Condenser (13-Plate .00025 mfd.); Ray-O-Vac  
Dry Battery, 4 cells 1 1/2 volts; Dubilier Variodon (.0004  
or .0006 mfd.); Resistometer (Type B); Delta Midget  
Tube and Socket; Thordarson Variable Condenser, .0005  
mfd.; Freshman Micon Condenser, .02 mfd.; B-Metal  
Crystal Tube Detector Type C; Aerovox 3-Gang Socket;  
Aerovox Double Slide Tuning Coil

#### Class F Articles

For twelve consecutively numbered coupons and one  
dollar and eighty cents (\$1.80) the following will be  
sent: 1 Acme Pot-Rheo (potentiometer and rheostat);  
Walnart Variable Condenser (23-Plate .0005 mfd.);  
Ray-O-Vac No. 2151 B Battery, 2 1/2 volts; Dubilier  
By-Pass Condenser (3 mfd.); Premier Variable Con-  
denser without dial (.00039 mfd.); Thordarson Variable  
Condenser, .001 mfd.; Amesco Compensating Grid Con-  
denser; Freshman Micon Condenser, 0.25 mfd.; Tele-  
radio Variable Condenser, 43-plate.

#### Class G Articles

For fourteen consecutively numbered coupons and two  
dollars and forty cents (\$2.40) any one of the following  
articles will be sent: 1 Federal 7-Plate Variable  
Condenser; 1 Federal 11-Plate Variable Condenser; 1  
Federal 21-Plate Variable Condenser; 1 Federal Anti-  
capacity Switch; 1 Demcal Variable Condenser 11-Plate  
Walnart Variable Condenser (43-Plate .001 mfd.); Du-  
bilier Variodon (.001 mfd.); Dubilier By-Pass Con-  
denser (4 mfd.); Premier Variable Condenser with dial  
(.00078 mfd.); Premier Hegehog A. F. Transformer, 4 to  
1 Ratio.

#### Class H Articles

For sixteen consecutively numbered coupons and three  
dollars (\$3.00) any one of the following articles will be

## FLEWELLING ANSWERS TO QUERIES

By E. T. Flewelling

(Editor's Note.—This department is written  
by Mr. Flewelling, the inventor of the famous  
super circuit. From the questions sent him  
each week care of Radio Digest, he picks the  
one considered most informative for all and  
answers it in this column.)

#### Variocoupler on Flewelling Super.

(Submitted by J. E., Brooklyn, N. Y.)  
Question. I am using a variocoupler on the  
Flewelling Super, tapped at 30, 40, 50, 75,  
100, 115 and 125 turns. Are these taps  
close enough? Rotor is 90 turns of No. 28  
wire. Is this enough? Volume is excel-  
lent, but do not secure much distance.  
Why?

Answer. You will have no trouble with a  
variocoupler tapped as you state. You  
should be able to tune in any broadcaster  
with this arrangement. Rotor will work  
with 90 turns, but would suggest about  
125 turns. Your trouble with distance may  
be caused by some shielding effect of  
neighboring buildings, etc. No trouble is  
ordinarily had from this source. The Su-  
per is at its best on distant stations.

#### Flewelling Antenna and Ground.

(Submitted by W. B., Cleveland, Ohio)  
Question. I have built a Flewelling set  
according to instructions and find that I  
can get no effect whatever from the vari-  
able condenser. Why? Also what can I do  
to overcome this?

Answer. The single condenser Super has  
been shown with the tuning condenser in  
series, with the tuning coil and the an-  
tenna, or, if the set is connected to the  
ground without any antenna, then the  
ground is connected to the top post so  
that the condenser is in series with the  
ground and the tuning coil. Now if the set

sent: 1 Federal Audio Frequency Transformer No. 228  
W; 1 Demcal 23-Plate Variable Condenser; 1 Acme  
Audio Frequency Transformer; 1 Acme Radio Fre-  
quency Transformer (R-2, R-3, or R-4); Walnart Vari-  
able Condenser (13-Plate vernier); Walnart Variable Con-  
denser (23-Plate vernier); Ray-O-Vac No. 2301 "B"  
Battery 45 volts; Ray-O-Vac Dry Battery, 6 cells 1 1/2  
volts; Dubilier Duratran (R. F. transformer); Premier  
Micrometer Variocoupler with dial; Premier Variable  
Condenser with dial (.0015 mfd.); Premier Variable  
Condenser with vernier (.0004 mfd.); Premier Hege-  
hog A. F. Transformer, 10 to 1 Ratio; Premier Hegehog  
A. F. Transformer, Tube Socket Type, 4 to 1 Ratio;  
Turney Spider Web Coil Mount, Type B.

is used without either antenna or ground,  
it is necessary in order to secure any  
effect from the condenser, to do either of  
two things: connect the antenna and  
ground posts together, thus placing the  
condenser across the tuning coil, or use a  
substitute antenna, such as a short wire  
10 to 15 feet long, a stove or other metal-  
lic body, even your own body will serve as  
an antenna if you hold the antenna post  
firmly in your hand. This matter of  
ground and antenna with the Flewelling  
is of very great importance and is one  
reason for failure. Any ground or antenna  
may be used. One will work practically  
as well as the next, but compensate or  
make up for these different values by  
change of either inductance or capacity in  
tuning the set.

## DENIES SECRET WAVES

(Continued from page 1)

When asked concerning the statement  
of C. C. Winn, dean of the College of En-  
gineering, Detroit Institute of Technology,  
Dr. Meissner was emphatic in his answer,  
"Winn has false information."

The statement of Dean Winn was given  
in the June 30 issue of the Digest. In it  
he supported the so-called secret waves  
as possible and entirely logical, even go-  
ing so far as to state that similar experi-  
ments as those attributed to Nauen by the  
American newspaper dispatches, had been  
carried out successfully in the laboratory  
of the Detroit Institute of Technology.

The stories branded by Dr. Meissner as  
foolish are unaccounted for in Germany,  
where they have also been rumored widely.  
It is the belief of many authorities that  
the dispatches gained credence through  
the desperate condition of Germany and  
a natural desire on the part of the Ger-  
mans to gain an upper hand over the  
French. The reports, however, are utterly  
false and German correspondents for  
many American daily newspapers are  
either uninformed or deliberately manu-  
facturing the propaganda.

Dr. Meissner, many Radiophans will re-  
call, is the inventor of the famous Meiss-  
ner circuit, widely used in transmitting,  
especially by the code amateurs.

Voltage is the pressure behind electrical  
current. Amperage is the current.



ON APPROVAL FOR 30¢  
ZOBEL-STEIN LABORATORIES  
322 9TH ST. BROOKLYN, N.Y. SOUTH 2650

## CUNNINGHAM TUBES REPAIRED

C-300 or UV-200	\$2.75
C-301 or UV201	3.00
C-302 or UV-202	3.50
C-301A or UV201A	3.50
WD-11 or WD-12	3.50
Moorehead Detectors	2.75
Moorehead Amplifiers	3.00
DV-6 or DV-6A	3.00
Also the new UV-199	3.50
NEW DX 1/2 VOLT TUBES	4.00

All tubes guaranteed to work like new.  
Mail Orders Given Prompt Attention  
"24 Hour Service"

## RADIO TUBE CORP.

55 Halsey Street Newark, N. J.  
TUBES SENT PARCEL POST. C. O. D.

## PREMIER "HEGEHOG" TRADE MARK

AUDIO  
FREQUENCY TRANSFORMER

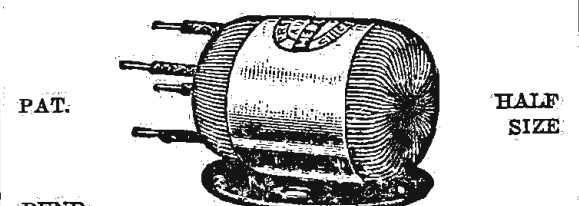

PAT. HALF SIZE  
PENDING.  
MAXIMUM VOLUME  
MINIMUM DISTORTION  
100 PER CENT SHIELDED  
MOUNTS ANYWHERE

PRICE \$3.50

RATIOS—1 to 3, 1 to 4, or 1 to 5

The Most Efficient, Compact Transformer  
ever designed. Ask Your Dealer for the  
Premier "Hegehog."

Full Specifications on Request

Premier Electric Company  
Est. 1905  
3810 Ravenswood Avenue, CHICAGO, ILL.

# CONTENTS

Radio Digest, Illustrated, Volume VI, Number 2, published Chicago, Illinois, July 21, 1923. Published weekly  
by Radio Digest Publishing Company, 123 West Madison Street, Chicago, Illinois. Subscription rates, yearly,  
Five Dollars; Foreign, Six Dollars; single copies, Ten Cents. Entered as second-class matter at the postoffice at  
Chicago, Illinois, under the Act of March 3, 1879.

"All the Live News of Radio".....	1 to 9
Flewelling Answers to Queries.....	2
High Up Among the Ether Waves.....	3
The Week's Advance Broadcast Programs.....	4
A Visit to WGY, Schenectady; Receiving Records.....	5
Survey of the Radio Patent Tangle, Part II, by John B. Brady.....	6
Photo Diagram of Jones Symphony Receiver and Three-Step Amplifier.....	7
Radiophone Broadcasting Station Directory, Part I—Station Schedules.....	8
An evening at Home with the Listener-In.....	9
Editorials; Indi-Gest; Condensed by Dielectric.....	10
First Steps for Beginners in Radio, Chapter X—Audio Frequency Amplification, by Thomas W. Benson.....	11
How to Make a Storage B Battery; Other Workshop Kinks.....	12
A New Single Tube Reflex Hook-Up; Characteristics of the Northern Electric 215A Tube, by H. J. Marx.....	13
Hook-Up Diagram R.D.-90; Book Reviews.....	14
Questions and Answers.....	15
Radio Illustrated, a Page of Pictures.....	16

## Looking Ahead

How to Graduate Your Variable Condenser Dials to Read in Wave Lengths and a  
discussion on the use of variable capacities in oscillating circuits, will be the  
topic of an article in next issue by H. J. Marx.

Thomas W. Benson's Series for Beginners next week will be devoted to a thorough  
explanation of super-regeneration, the latest Radio Development.

Hook-Up Diagram R.D.-91—to appear in the July 28 issue—will show a new  
development of the Ultra Reinartz. This circuit will employ the tuning unit  
described several months past in the Digest series on the Ultra Reinartz.

The Survey of the Radio Patent Tangle—by John B. Brady—will continue next  
week, ending week after next. This explanatory study of the invention muddle is  
worth keeping on file.

More Broadcast Advance Programs Than Any Other Source—Every issue the  
detailed programs are given for the country's leading stations that are able to  
supply this information far enough in advance. Twenty-three are included this  
issue. Watch the department grow.

Have a Copy with You on  
Your Vacation

WHEN YOU WANT

# Radio Digest

YOU WANT IT!

BE SURE OF YOUR WEEKLY COPY  
BY SUBSCRIBING NOW

SEND IN THE BLANK TODAY

Publisher Radio Digest,  
123 West Madison St.,  
Chicago, Illinois.

Please find enclosed check M. O. for Five Dollars  
(Plus Foreign) for One Year's Subscription to  
Radio Digest, Illustrated.

Name .....

Address .....

City..... State.....

# MASTER HEARS LAST WORK OF HIS PUPIL

## RADIO INSTILLS LIFE IN STUDENT'S MASTERPIECE

Italian Musician Listens In to Final Composition of His Famous Protege

SAN FRANCISCO.—Probably not more than a dozen persons were cognizant of the drama of the air that was enacted recently, when Guiseppi Bartalo, aged teacher of Luigi Mancinelli, author of the motion picture opera "Frate Sole," which was presented at the Civic Auditorium in San Francisco, sitting in far off New Orleans, heard his pupil's last composition broadcast here from Station KPO, Hale Bros, Inc., of San Francisco.

It was Bartalo, Italian maestro, who, many years ago, shaped the musical foundation of little Luigi Mancinelli in far off Milan, when the little boy with the serious eyes came to him for his initial instruction. Proudly he watched the fruits of his labors, as Mancinelli developed into a noted composer, whose operatic and symphonic scores were familiar to musical thousands.

### Pupil Becomes Famous

While Mancinelli was climbing the thorn-strewn pathway to fame, Bartalo was establishing himself in America. Their roads parted. Mancinelli climbed to the top of his profession, but he never forgot the little instructor to whom he owed his beginning. Frequently he wrote him, and sent him copies of his newest scores. And Bartalo's breast would swell with pride, and he would tell his friends tales of his Luigi as he always remembered him.

In 1922 Mancinelli died. Bartalo was heartbroken. He collected all of his dead pupil's works that he could find. But some of his latest works he overlooked. One such was "Frate Sole," which he had never heard. No more had America. When arrangements were made to bring "Frate Sole" to this country, no one thought of little Bartalo in New Orleans until the broadcast.

### World Hears Opera

When a pre-audition was arranged through Station KPO that the Radio world might hear a fragment of the dead composer's work, friends recalled the aged maestro in New Orleans. Telegrams were interchanged. As a result of them, little, old, bent Guiseppi Bartalo sat at a Radio instrument half across the American continent, and with tears streaming down his cheeks, as he later explained by a telegram to KPO and his friends, heard again through the wizardry of a broadcast wave the living fire of "Little Luigi" in his ears.

The whole coast listened to "Frate Sole." But only a few, those who had arranged the matter, visualized the greater drama which was being enacted in New Orleans as Guiseppi Bartalo, at his Radio set heard the last work of his beloved pupil.

# "CHURCH WILL GROW BY SERMONS IN AIR"

COLUMBUS, O.—"Radio will soon be the biggest asset in bringing people to the church because people will want not only to hear the pastor, but to see and meet him," Rev. Dr. Andrew W. Blackwood said in his talk a few days ago to pastors who are attending the summer school of pastors at Ohio State university. His topic was, "The Most Popular Preacher."

# UNCLE JOE KEEPS IN TOUCH BY AIRPHONE

DANVILLE, ILL.—Out of politics forever and back to this, his own old home town, Uncle Joe Cannon, for many years speaker in the House of Representatives, keeps in touch with the outside world by means of Radio. A complete Radio set was presented the venerable gentleman on his 87th birthday, and Uncle Joe is now an ardent fan.

# UP AMONG THE ETHER WAVES

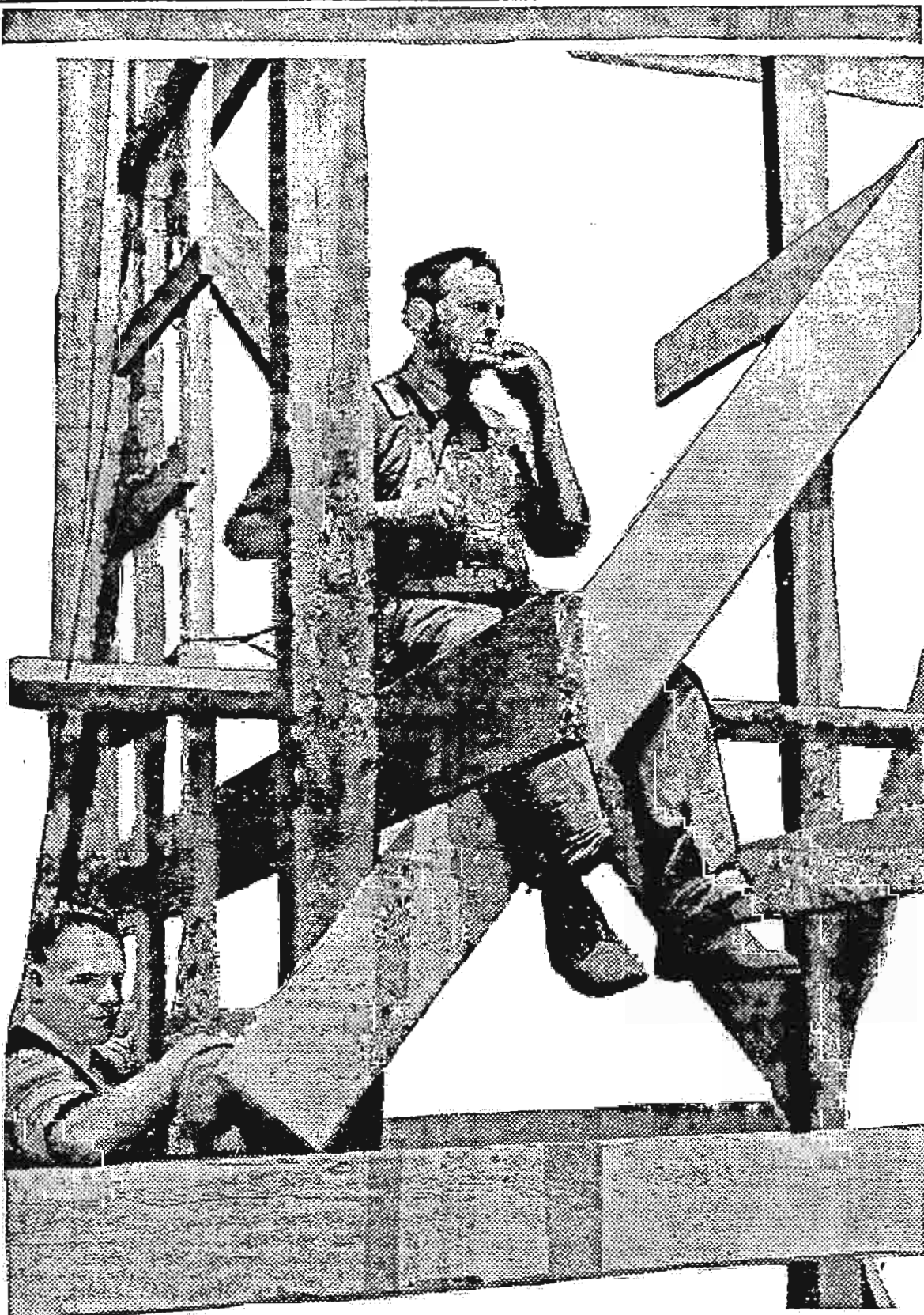

Steeplejack Michael Bourke of Brooklyn just drops a wire from his small crystal set at noon hour and listens to all the locals. In this instance he is enjoying Station WDT between bites

© K. & H.

# Desolate Miners' Village Relies on Air for News

Town Is Four Days from Rails; Gets Mail Every Six Weeks

DETROIT.—The Detroit News, Station WWJ, recently received a communication from E. E. Carter, Holt Mine, McColl, Idaho, which shows how Radio is appreciated by persons shut from the world during a large part of the year. Mr.

Carter's letter reads in part: "We are located at an altitude of 7,000 feet and a four day trip to the nearest railway. To travel anywhere we have to navigate 10 to 30 feet of snow. We get mail once every six weeks brought in by ski riders—but only letters at that, for newspapers are too bulky.

"We put in supplies to last at least eight months of the winter. You can imagine how much the enlightenment and the entertainment received from WWJ and other broadcasting stations has meant to us."

# FEATURE STARS AT WMAQ'S REOPENING

## EXCELLENT MODULATION MARKS REBUILT PLANT

Two Huge 135-Foot Towers, Atop Hotel, Give Antenna Total Height of 450 Feet

CHICAGO.—WMAQ, the Chicago Daily News, latest addition to Chicago's many high powered broadcasting stations, recently opened its brand new studio with an exceptionally fine program, in fact two programs, as they broadcast two different times during the evening: 7 to 8 and 9 to 10.

Some of the outstanding features of the earlier program were Willie and Eugene Howard and Emily Mills of Passing Show fame; the three Doners Tad, Rose, and Kitty of the Dancing Girl; Edythe Baker, pianist, who is scheduled as the star of the Music Box Revue for the coming season; Edith Fletcher, coloratura soprano of the Cleveland Opera Company, and a talk by Earnest Stevens of the LaSalle Hotel. Mr. W. S. Hedges, Radio Editor of the Daily News, also gave a short address.

### Later Program

The later program from WMAQ was along different lines. Miss Myrna Sharlow, leading soprano of the Chicago Civic Opera Company, sang several numbers and Vera Poppe, English cellist, well known to Radiophans throughout the country, provided excellent entertainment.

The Studio of WMAQ is an example of the newest ideas for Radio Broadcasting. The studio, comprising two large rooms, is located on the eighteenth floor of the Hotel LaSalle, with a commodious reception room adjoining. The walls have been specially treated and are hung with taupe velour. Several prominent acoustic engineers who inspected the studio said that it is perfectly arranged for broadcasting, there being absolutely no echoes. Thick carpet covers the floor to muffle any noise which might arise from that source.

Several microphones placed about the studio proper have lines running to the control station at one end of the room and are so connected that one or more may be connected simultaneously, according to the demands of the occasion.

### On Top of Twenty-Two Stories

Located in a penthouse on the roof of the hotel, is the operating room. The latest equipment is used, consisting of a 500-watt transmitter. Two steel towers, each 135 feet high and spaced 100 feet apart, support the antenna. As these towers are located on the roof of the twenty-two story hotel building, the antenna is the highest of any in the city. An interesting feature of these towers is that they are coated with a fireproofing cement for half their height.

# SIGNAL OFFICER IS GIVEN NEW POST

Major Maubourgne, Headquarters, Chicago, Goes to Experimental Laboratory at Washington

WASHINGTON.—Maj. J. O. Maubourgne, former chief signal officer of the 6th corps area, headquarters at Chicago, has been placed in charge of the Signal Corps Laboratory at the Bureau of Standards. Maj. Maubourgne expects to begin a new series of experiments in the laboratory July 15.

One of the first is the development of suitable terminal apparatus for transmitting Gen. George O. Squier's new universal speed code alphabet. In view of the fact that the alphabet is intended to increase the speed of automatic transmission in cable, wire and Radio dispatches, the development of the necessary apparatus is very complicated. As soon as the apparatus can be built the army message center here plans to conduct long distance speed transmission tests.

# RACE CONTESTANTS ARE RADIO EQUIPPED

Five of Entries in Balloon Classic Have Radio Sets Aboard

INDIANAPOLIS, IND.—Five of the contestants in the national balloon race which started from Indianapolis July 4 were equipped with Radio receiving sets, using dry cells and peanut tubes. The sets weigh less than eighteen pounds and have a range of more than 1,000 miles.

The sets were used to pick up special weather reports, telling of various air currents at different altitudes, prepared by the weather bureau and broadcast from Washington, Detroit, Chicago and Schenectady, N. Y. In view of the fact that the winner of the race was the balloon that got the greatest distance from the starting point, the reports on air currents were of great value.

# THE ANTENNA BROTHERS

Spir L. and Lew P.

Inject this in Your DX Friends

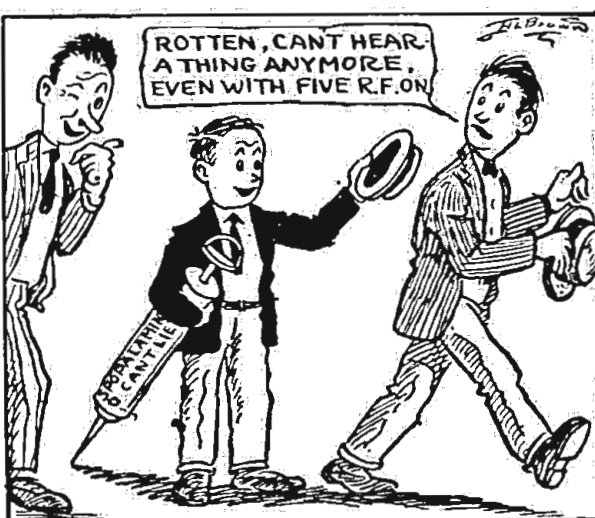
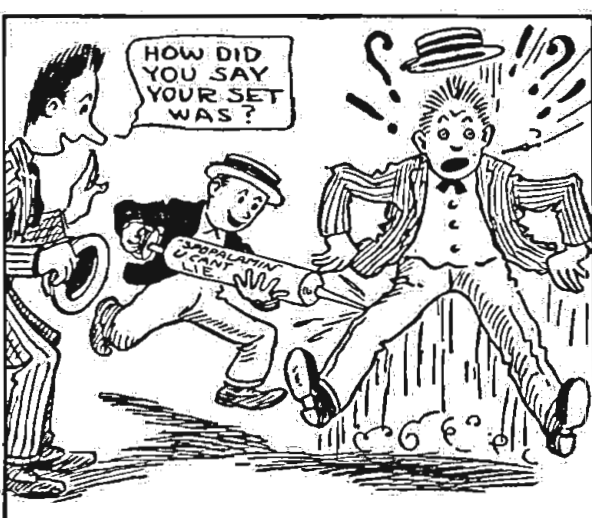
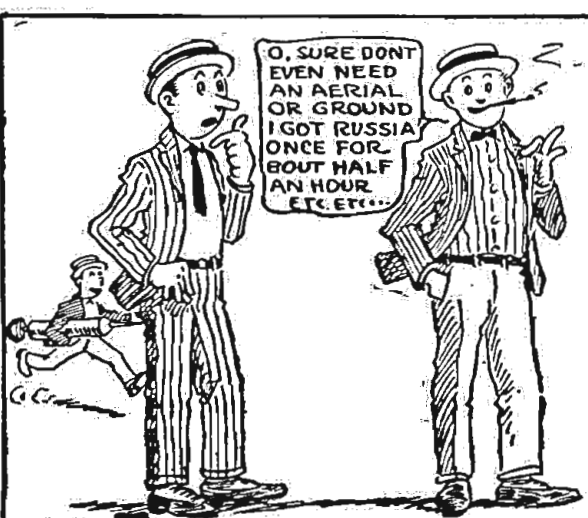
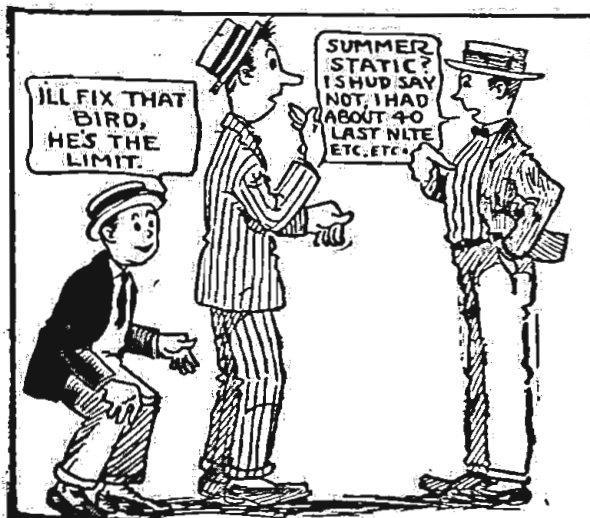

# The Week's Advance Broadcast Programs

## Tuesday, July 17

**CFCA** (Eastern, Daylight Saving, 400), 8:00-9:00 P. M., Musical program, "Keltic," Star Orchestra; "A Song of Sunshine," Mrs. Isobel G. Callow, contralto; "Concerto," Manny Roth, violinist; "Serenade," Orchestra; "Salaam," Mrs. Isobel G. Callow; "Badinage," Orchestra; "Spanish Dance," Manny Roth; "Cossack Lullaby," "Serenade Espagnole," Orchestra; "Yesterday and Today," Mrs. Isobel G. Callow; "A Ball Scene," Orchestra.

**KDKA** (Eastern, 326), 7:20 P. M., Concert, "Prelude in G Minor," "Waltz in E Major," "Paraphrase Rigolotto," Esther Burnett, pianist; "Love in Idleness," "In the Deep Cellar," "Rocked in the Cradle of the Deep," Harvey Anshutz, bassoon; Harve Lauderbaugh, bass; E. Godfrey, reader.

**KGW** (Pacific, 492), 3:30-4:00 P. M., Woman's program devoted to Child Training; 10:00-11:00 P. M., Dance music, George Olsen's Orchestra.

**KHJ** (Pacific, 395), 12:30-1:15 P. M., Concert, Beisden's Bon Ton Ballroom Orchestra; 2:30-3:30 P. M., Matinee musical, Oris Cook Concert Trio; 6:45-7:30 P. M., Children's hour, "Uncle John"; 8:00-10:00 P. M., De Luxe program.

**KSD** (Central, 546), 8:00 P. M., Concert, Grand Central Theater talent.

**KYW** (Central, Daylight Saving, 345), 8:00-8:58 P. M., Musical program, Lyon & Healy Concert Dept.; Cope Harvey's Orchestra; Herb Mintz, pianist; 9:00-9:35 P. M., Book review, Lewlyn Jones.

**WBAP** (Central, 476), 9:30-10:45 P. M., Concert, Fred Cahoon's Texas Hotel Orchestra.

**WBZ** (Eastern, 337), 7:00 P. M., Concert, William Davison, tenor; Avis Harriman, soprano; Mrs. E. H. Ruhe, pianist; 8:30 P. M., Bedtime story for grown-ups, Orison S. Marden.

**WDAR** (Eastern, Daylight Saving, 395), 12:00-12:54 P. M., Organ recital, Stanley Theater; Dinner music Arcadia Cafe Concert Orchestra; 2:00-3:00 P. M., Musical selections; 4:30-5:55 P. M., Song recital; Talk, Betsy Logan.

**WDT** (Eastern, Daylight Saving, 405), 12:00-1:00 P. M., Popular songs; "Midnight Road," "Long Lost Mama," "When the Sun Shines for Me," "Ten Thousand Years," "Honey Moon Time," "Bebe—Slow Poke," "Bug House Fables."

**WFAA** (Central, 476), 12:30-1:00 P. M., Address, De Witt McMurray; 8:30-9:30 P. M., Violin recital, Edith Bellharz and assisting musicians; 11:00-12:00 P. M., Musical program, J. I. Wright's Male Quartet.

**WFI** (Eastern, Daylight Saving, 395), 1:00 P. M., Dinner music, Meyer Davis Bellevue Stratford Orchestra; 3:00 P. M., Piano recital, Loretta Kerk; 6:30 P. M., Dinner music, Meyer Davis Bellevue Stratford Orchestra; 7:00-7:30 P. M., Children's Own Half Hour, Cousin Sue; 8:00 P. M., Boy Scouts Radio Corps; 8:30 P. M., Song recital; 10:30 P. M., Dance Music, Meyer Davis Bellevue Stratford Dance Orchestra.

**WGI** (Eastern, Daylight Saving, 360), 8:30 P. M., Business report, Roger W. Babson; Joseph Ecker, baritone; Mrs. Grace Phillips, pianist; Talk, George Brinton Neal, Editor Boston Sunday Post.

**WGW** (Eastern, 380), 1:00 P. M., Address, "The Woman of Today," Mrs. Charles E. Hyson; 7:45 P. M., Musical program, "Venezia Carnival Pranks," Ruth Don, pianist; "The Cloths of Heaven," "The Crying of Water," Everett T. Grout, tenor; "Solfeggetto," "Allegro di Molto," Ruth Don; "Onaway, Awake, Beloved," Everett T. Grout; "Sonata in A Major," Alice Clough-Wilsey, violinist; "Concerto," Ruth Don; "Trabblin' to de Grave," "Hard Trials," "Everett T. Grout; "Danse Negre," Ruth Don; "The Rosary," Everett T. Grout; "Andante," "Melodie," Alice Clough-Wilsey; "Prelude and Fugue No. 21," "Prelude No. 22," Ruth Don.

**WHAS** (Central, 400), 4:00-5:00 P. M., Concert, Mary Anderson Theater Orchestra; 7:30-9:00 P. M., Concert, Mary Anderson Theater Orchestra; Carolyn Pell, soprano; Richard Wymond, violinist; Double piano concerto, Mrs. Lawrence Evans, Ruth Sharp; Bryan Holloway, baritone; Mrs. Lawrence Evans, pianist; Elizabeth S. Steiger, Robert F. Muth, readers; Ruth Sharp, pianist.

**WIP** (Eastern, Daylight Saving, 509), 1:00-2:00 P. M., Organ recital, Karl Bonaris; 3:00 P. M., Artists' recital, song and piano; 6:00 P. M., Dinner music, WIP Little Symphony Orchestra, Dick Regan, director; 7:00-7:30 P. M., Bedtime stories, Uncle Wip; 8:30 P. M., Musical program.

**WJAX** (Eastern, 390), 7:30 P. M., Concert, Cleveland News.

**WLW** (Eastern, 309), 10:00 P. M., "The Mountebank's Song," Mabley and Carew Glee Club; Vocal solo, Mr. Sanders; Henry Grad, baritone; "Anchored," Glee Club; Vocal solos, Mr. Sanders, Mr. Grad; "The Day is Declining," Glee Club; Circle Orchestra.

**WMAQ** (Central, Daylight Saving, 448), 4:30 P. M., Program furnished by Cosmopolitan School of Music and Dramatic Art; 7:00 P. M., Stories, Georgene Faulkner; Frances Aiken, pianist; Mrs. Beatrice Solomon, violinist; 9:15 P. M., Program arranged by Lyceum Arts Conservatory.

**WOC** (Central, 484), 3:30 P. M., Educational talk, Clyde G. Kern; 8:00 P. M., Organ recital, Erwin Swindell, organist; Musical program, Rita Harris, conductor; "She's Got That Too," "Thelma," "Somebody Else," Alchele Novelty Orchestra; "Spanish Caprice," Mildred Steinwert, pianist; "Serenade," Mitchell Dana, viola; "Bach Concerto for Two Violins in D Minor," Mitchell Dana, Irwin Korb, violinists; "Prelude in G Sharp Minor," "Witches Dance," Mildred Steinwert; "Liebestreud," Mitchell Dana; Alchele Novelty Orchestra.

**KYW** (Central, Daylight Saving, 345), 8:00-8:58 P. M., Musical program, Marie Emery Lehr, soprano; Howard Nielson, tenor; Cope Harvey's Orchestra; Harry Geise.

**WBAP** (Central, 476), 9:30-10:45 P. M., Concert, Ft. Worth artists.

**WBZ** (Eastern, 337), 7:00 P. M., Concert, Mrs. Lila L. Morgan, soprano; John Clark, pianist; Lloyd Stoneman, pianist; 8:20 P. M., Bedtime story for grown-ups, Orison S. Marden.

**WDAR** (Eastern, Daylight Saving, 395), 12:00-12:54 P. M., Organ recital, Stanley Theater; Dinner music Arcadia Cafe Concert Orchestra; 2:00-3:00 P. M., Musical selections; 4:30-5:55 P. M., Song recital; Talk, Betsy Logan.

**WHAS** (Central, 400), 4:00-5:00 P. M., Concert, Mary Anderson Theater Orchestra; 7:30-9:00 P. M., Concert, Courier-Journal Quartet; Reading, "An Interesting Historical Episode."

**WIP** (Eastern, Daylight Saving, 509), 3:00 P. M., Recital; 6:00-6:45 P. M., Dinner dance music; 7:00-7:30 P. M., Bedtime stories, Uncle Wip.

**WLW** (Eastern, 309), 8:00 P. M., Musical program, "La Cinquantaine," "Ein Albinblatt," Frances Stofregen, cellist; Alchele Novelty Orchestra; Swimming lesson, Stanley Brauning; Popular songs, Gussie

tralto; Amy Kileen, soprano; T. M. Arnold, trombone; 10:00 P. M., Musical program, Davenport Chapter, Order of the DeMolay.

**WOO** (Eastern, Daylight Saving, 509), 11:00-11:30 A. M., Organ recital, Mary E. Vogt; 12:00-12:55 P. M., Luncheon music, Wanamaker Tea Room Orchestra; 4:45 P. M., Organ recital, Mary E. Vogt; 8:00 P. M., Recital.

**WVJ** (Eastern, 517), 3:00 P. M., Concert, Schmeman's Band; 8:30 P. M., News Orchestra; Town Crier; Julius Sturm, soprano; Lilah G. Grant, soprano; Deora Wolfe, pianist.

## Thursday, July 19

**CFCA** (Eastern, Daylight Saving, 400), 8:00-9:00 P. M., Musical program, "Cavalleria Rusticana," Star Orchestra; "Nervana," Fred S. Hamer, tenor; "Nina," Jaques Stern, cellist; "Le Retour," Orchestra; "A Farewell," Fred S. Hamer; "España," Orchestra; "Ritornell," Jaques Stern; "The Last Watch," Fred S. Hamer; "Serenade," Selection from "Kalinka," Orchestra.

**KDKA** (Eastern, 326), 7:20 P. M., Concert, Elmer Hennig, cellist; William Hennig, Jr., pianist.

**KGW** (Pacific, 492), 3:30-4:00 P. M., Lecture, "The Analysis of a Simple Bank Statement," Andrew Miller, Field Secy. Oregon Bankers Assn.; 10:00-11:00 P. M., Dance music, George Olsen's Orchestra.

**KHJ** (Pacific, 395), 12:30-1:15 P. M., Concert; 2:30-3:30 P. M., Concert; 6:45-7:30 P. M., Children's hour, "Uncle John"; 8:00-10:00 P. M., De Luxe program.

**KYW** (Central, Daylight Saving, 345), 8:00-8:58 P. M., Musical program, Cope Harvey's Orchestra; Herb Mintz, pianist; Margaret M. Miller, soprano; Geo. S. Cuthbertson, tenor; Clyde W. Foster, baritone; 9:05-9:25 P. M., "Twenty Minutes of Good Reading," Rev. Claude J. Perrin.

**WBAP** (Central, 476), 9:30-10:45 P. M., Concert, Florence Higgins' Orchestra.

**WBZ** (Eastern, 337), 7:00 P. M., Concert, William Levin, pianist; Cecil Lussier, soprano; Lillian De Laurier, violinist; WBZ Trio; 8:20 P. M., Bedtime story for grown-ups, Orison S. Marden.

**WDAK** (Eastern, Daylight Saving, 395), 12:00-12:50 P. M., Organ recital, Stanley Theater; Dinner music, Arcadia Cafe Concert Orchestra; Ferd Sarkoz, director; 2:00-3:00 P. M., Arcadia Concert Orchestra; Talk, Betsy Logan; 4:30-5:55 P. M., Song recital.

**WDT** (Eastern, Daylight Saving, 405), 12:00-1:00 P. M., Popular program, "Snakes, Hips," "I'm Going Away," Spencer Williams; "You're Always Messing Around With My Man," "Low Down Papa," "Cotton Belt Blues," Lizzie Miles; "Black Man, Be On Your Way," "Down Hearted Blues," "Gulf Coast Blues," Edna Hicks; Songs, Spencer Williams.

**WFAA** (Central, 476), 12:30-1:00 P. M., Address, "The Courts and the People," Judge Royal R. Watkins; 8:30-9:30 P. M., Musical program, arranged by D. L. Whitte Music Co.

**WFI** (Eastern, Daylight Saving, 395), 1:00 P. M., Dinner music, Meyer Davis Bellevue Stratford Orchestra; 3:00 P. M., Song recital; 3:45 P. M., Concert;

## What Time Is It?

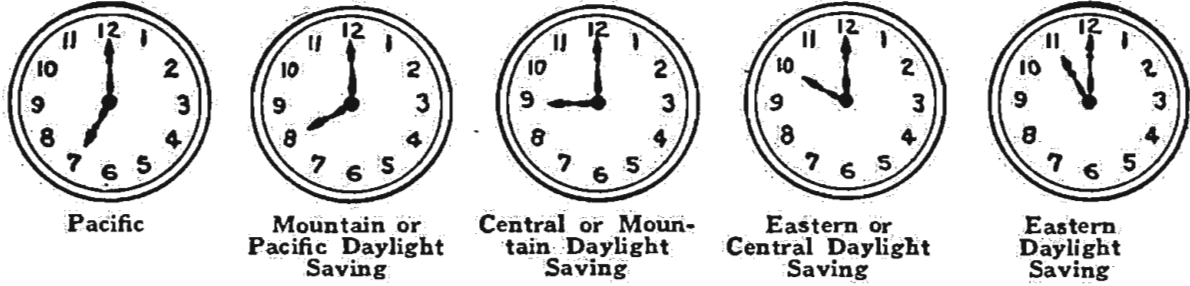

THE above clock dials are shown to clear up the misunderstanding which the various time bands and the Daylight Saving plan are creating. Although each dial registers time one hour ahead or behind of its neighbor, the exact period indicated on each dial is the same as that on every other. This chart will aid in the use of the advance programs and the schedules in the Radiophone Broadcasting Station Directory, both of which give the hours stated in the particular kind of time in use at each station. Only features are listed in the advance programs below. Much additional data and such parts of station schedules as are regular features week in and week out, will be found in the station directory which appears serially continuously on page eight.

P. M., Organ recital, Stanley Theater; Dinner music, Arcadia Cafe Concert Orchestra; 2:00-3:00 P. M., Song recital and short talks; 4:30-5:55 P. M., Dance music; 7:30-8:00 P. M., Dream Daddy; 8:00 P. M., 1:00 A. M., Talks, song recital, dance music, Arcadia Cafe Dance Orchestra; Howard Lanin, director; Songs, Harry Glyn.

**WDT** (Eastern, Daylight Saving, 405), 12:00-1:00 P. M., Musical program, "Wonder," "Oh How She Lied," Ruby Cowan, singer; Willie White, pianist; Comedy songs, Bernie Grossman; "Oh Sister Ain't That Hot?" Ruby Cowan; "Chattahoochee," sung by composer; Songs, Brooks and Bos; 7:00-7:50 P. M., Sandman's story, Lila Lee; Piano recital, Jascha Samois; "My Grief May Be Quiet," "Polianka," "Flower, Wine and Love," Sophia Maximova, Gypsy singer; Miss Alexander, actress; "As the King Went to War," "Aria from the Opera Demon," "Aria from the Opera Pique Dame," Mr. Kotlyansky, bass; "Today We Have Parted," "It May Be," "Troika," Madame Maximova; "The Two Grenadiers," "I Will Never Be Grieved," "Ei Uchniem," Mr. Kotlyansky.

**WFAA** (Central, 476), 12:30-1:00 P. M., Musical program, Melba Theater talent.

**WFI** (Eastern, Daylight Saving, 395), 1:00 P. M., Dinner music, Meyer Davis Bellevue Stratford Orchestra; 3:00 P. M., Recital; 6:30 P. M., Dinner music, Meyer Davis Bellevue Stratford Orchestra; 7:00 P. M., Children's Own Half Hour, Cousin Sue.

**WGI** (Eastern, Daylight Saving, 360), 8:30 P. M., Talk, "Science Up to Date," Scientific American.

Bishop; "She's Got That Too," "Thelma," "Somebody Else," Alchele Novelty Orchestra; "Spanish Caprice," Mildred Steinwert, pianist; "Serenade," Mitchell Dana, viola; "Bach Concerto for Two Violins in D Minor," Mitchell Dana, Irwin Korb, violinists; "Prelude in G Sharp Minor," "Witches Dance," Mildred Steinwert; "Liebestreud," Mitchell Dana; Alchele Novelty Orchestra.

**WMAQ** (Central, Daylight Saving, 448), 4:30 P. M., Program furnished by Cosmopolitan School of Music and Dramatic Art; 7:00 P. M., Stories, Georgene Faulkner; Frances Aiken, pianist; Mrs. Beatrice Solomon, violinist; 9:15 P. M., Program arranged by Lyceum Arts Conservatory.

**WOC** (Central, 484), 3:30 P. M., Educational talk, Clyde G. Kern; 8:00 P. M., Organ recital, Erwin Swindell, organist; Musical program, Rita Harris, con-

## WILLARD RADIO COMPANY

291 Broadway New York City

**FLEWELLING CIRCUIT**  
Every part complete, including drilled panel and book of diagrams and instructions ..... \$11.95

**REINARTZ CIRCUIT**  
Every part complete, including drilled panel and book of diagrams and instructions ..... \$10.95

Two-stage Audio-Frequency Amplifier. Every part complete for either of the above circuits at ..... \$11.00

CONDENSERS	
3 Plate Variable; value, \$1.75	\$1.05
13 Plate Variable; value, 2.50	1.20
23 Plate Variable; value, 3.50	1.35
43 Plate Variable; value, 4.50	1.95
13 Plate Vernier; value, 5.50	3.75
23 Plate Vernier; value, 6.00	4.00
43 Plate Vernier; value, 6.50	4.25

Honeycomb Coils, 50 turns mounted	.95
Honeycomb Coils, 75 turns mounted	1.00
Double Coil Mountings	2.45
Triple Coil Mountings	3.35
Reinartz Coils, increased wave length and mounting	1.55
Jacks, Single Circuit; value, 65c; special at	.30
Double Circuit; value, 90c; special at	.45
Multiple Point Inductance Switch with Knob and Dial (15 Switch Points)	1.45
Lightning Arresters, approved	.90
Three-inch Dials, unbreakable, heat resisting composition, high finish; special	.30

Two-inch Dials, same design, for rheostats and potentiometer; special at	\$.25
Audio Frequency Transformer. Designed for use with W. D. 11 tubes; list, \$4.50; price, 2.75	
Variocoupler—Litz Wire Wound Secondary; value, \$4.50; special	2.25
Ball Bearing Inductance Switch; value, 75c; special	.30
V. T. Sockets, nicked, brass, sleeve, composition base; value, \$1.00; special at	.40
Aluminum Loud Speaking Horn, nickel plated, highly polished; \$8.00 list	3.75
Filament Rheostat, 6 ohm	.65
Filament Rheostat, 20 ohm	.80
Filament Rheostat, 50 ohm	.90
With 2" Dial, 15c extra.	

Every article advertised above is guaranteed by the manufacturer and by us. Mail orders filled immediately. Transportation PREPAID on all orders of \$5.00 or over, east of the Mississippi River. All others include postage.

## RADIO VIA PARCEL POST AT N. Y. PRICES

Standard Parts Only, in Original Packing  
NO SALVAGED GOODS SOLD  
Where "Money Back Policy Prevails"

**MARGO \$1.00**  
Vacuum Tube 1 Socket  
1 1/2 Volt

Operates on one dry cell, either with or without B battery. Wiring diagram FREE with each tube. 10c extra for parcel post insured.

PHONES	
Dietzen 3,000 Ohm	\$3.75
Dictograph	5.75

COUPLERS	
King Variocoupler	1.15

VARIABLE CONDENSERS	
Dietzen 14-Plate Vernier	2.65
Dietzen 24-Plate Vernier	2.95
Dietzen 46-Plate Vernier	3.45

TRANSFORMERS (Audio Frequency)	
Dietzen	3.45

TRANSFORMERS (Radio Frequency)	
Cotoco	2.45
Owl	.95

MISCELLANEOUS	
Ritter Portable Loop	1.00
Argus Lightning Arrestor	.95
Welsh Peanut Tube	2.00
Peanut Tube Socket	.50
Switch Lever, Fada Type	.10
Ammeter Testing B Battery	.49
Two Slide Tuning Coil	1.26
Hydrometers	.49
Double Phonograph Attachment	1.15

SETS	
Giblin Crystal Set	4.95
Aerex Crystal Set	7.95
Victor Single Tube, completely assembled	12.50
Victor Two Stage Amplifier	12.50

RHEOSTATS	
Klosner Vernier	1.25
Bradleystat	1.49
Union Radio	.65

SOCKETS	
Bell V. T. & W. D. 11	.89
V. T. Bakelite	.50

LOUD SPEAKERS	
Music Master	27.50
Reflex	9.85

DIALS	
2-inch (Bakelite)	.25
3-inch (Bakelite)	.35

**Modell's**  
ESTABLISHED 1899

191 Fulton St., Dept. F-22, New York City  
9 New York Stores  
America's Greatest Radio Mail Order House

## Just Consider

—the essential features necessary to make an audio frequency transformer a good one—

1. High Amplification.
2. Minimum Distortion.
3. Low Interstage Linkage.
4. Convenient Mounting.
5. Compactness.

Cotoco transformers make these ideal features facts. And the finish will surely please you.

"Built First to Last"  
\$5.00  
At Your Dealer's

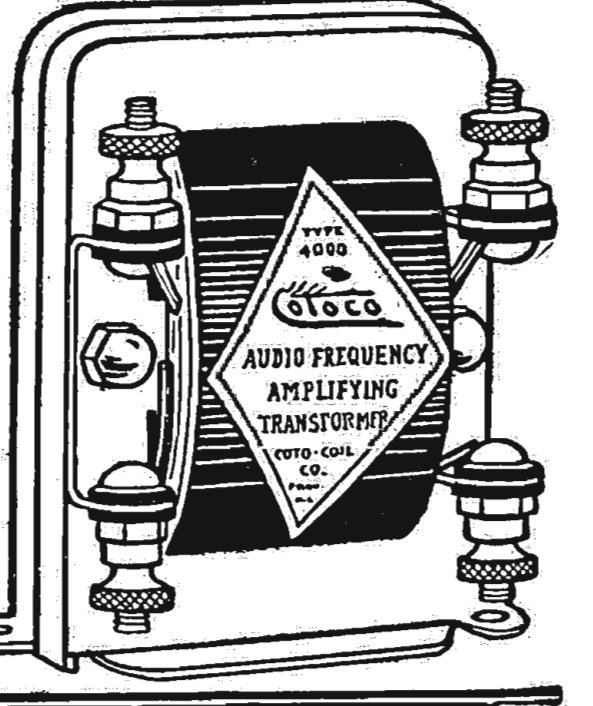

PACIFIC COAST BRANCH:  
329 Union League Bldg.  
LOS ANGELES

## COTO-COIL CO. PROVIDENCE

## Wednesday, July 18

**CFCA** (Eastern, Daylight Saving, 400), 8:00-9:00 P. M., Musical program, Selection from "Il Trovatore," Star Orchestra; "The Dwarf," Arthur Fisher, baritone; Cornet solo, W. Woods; "Serenade," Orchestra; "Toggling Along the Highway," Arthur Fisher; "My Dreams," Orchestra; Cornet solo, W. Woods; Selection from "Chu Chin Chow," Orchestra; Baritone solo, Arthur Fisher; "Lysistrata," Orchestra.

**KDKA** (Eastern, 326), 7:20 A. M., Concert, KDKA Little Symphony Orchestra, Victor Saudek, director; Earl Renner, tenor.

**KGW** (Pacific, 492), 3:30-4:00 P. M., Children's program; stories, Aunt Nell; 8:00-9:00 P. M., Concert; 10:00-11:00 P. M., Dance music, George Olsen's Orchestra.

**KHJ** (Pacific, 395), 12:30-1:15 P. M., Musical program; 2:30-3:30 P. M., Matinee concert; 6:45-7:30 P. M., Children's hour, "Uncle John"; 8:00-10:00 P. M., De Luxe program.

**POSITIVE RESULTS**  
are being obtained by thousands of satisfied users of the  
**EASTERN COIL SETS**  
for the  
**COCKADAY CIRCUIT**

The remarkable features which are making this circuit more popular each day are its simplicity of construction and control—wonderful selectivity—distance records—clearness and loudness of reception, and the fact that all capacity squealing, interference, etc., are eliminated.

Made as per specifications of Mr. Cockaday, using No. 18 wire with D coil bank-wound.

**COMPLETE SET OF B, C AND D COILS—PRICE \$2.75**

Hook-up, directions and material list furnished free with each set of coils.

Mail Orders Filled. Dealers Communicate  
**EASTERN RADIO MFG. CO.**  
22 WARREN STREET NEW YORK, N. Y.

# A VISIT TO WGY, SCHENECTADY

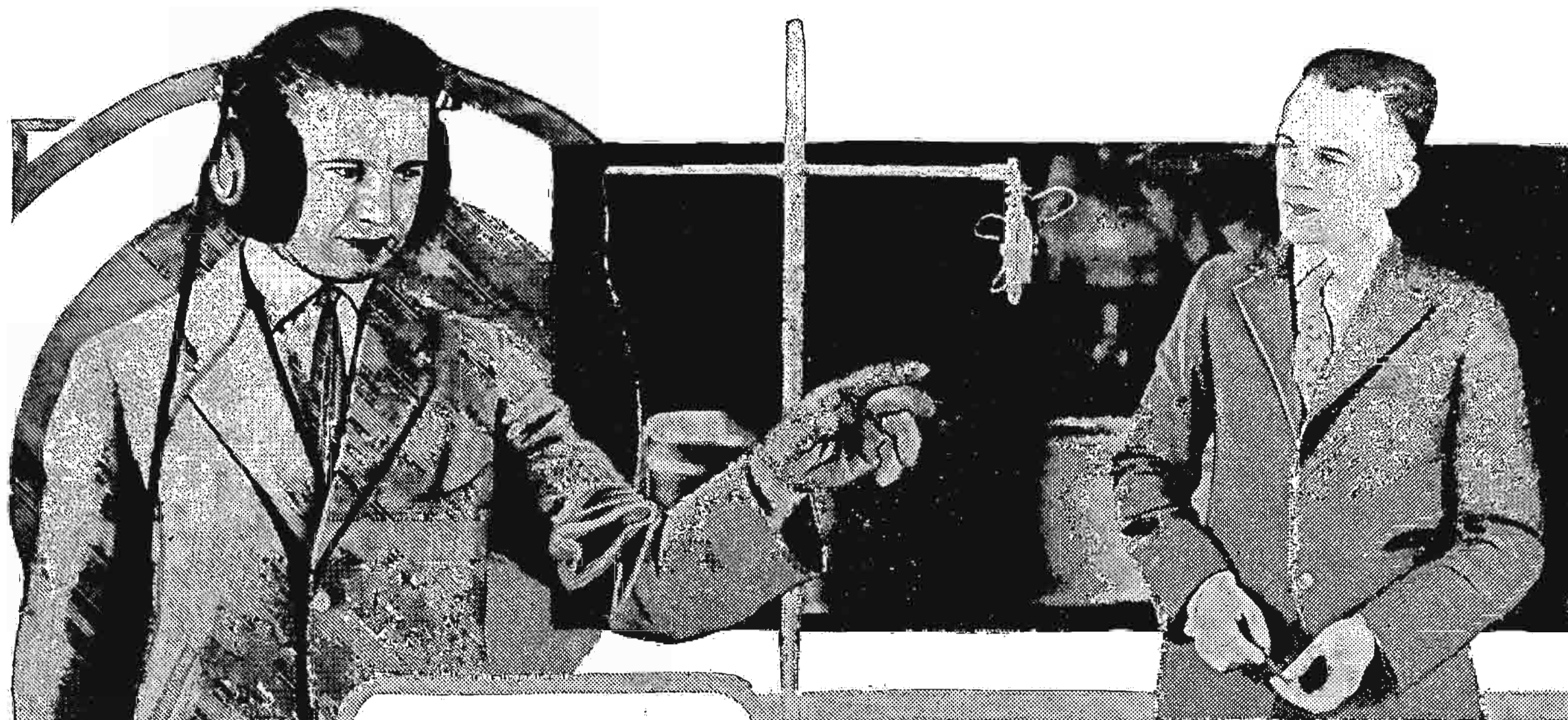

Robert Weidaw (left), announcer, acting as censor of WGY Players. By means of muffled headset he hears drama by Radio and directs actors closer to or away from microphone, as is necessary. Kolin Hager (right), studio director and chief announcer at WGY, giving the fans, "This is WGY, Schenectady"

## Radiophans So Enthusiastic Over WGY They Even Christen Their Babies After It

Kolin Hager Outstanding Figure of Popularity at Famous Eastern Station of General Electric Company Does Interesting Experiments in Drama and Remote Control Broadcasts

By Vera Brady Shipman

The Radiophans are so enthusiastic about WGY that they even name their babies after it. Out in Kansas, the fond parents have written that their son and heir is named William Gordon Yadon. There you are—WGY for a lifetime.

I had always thought of Schenectady as something out of a comic opera back in the days of Fay Templeton singing "On the Day I Left Schenectady" in George M. Cohan's "Forty-Five Minutes from Broadway." Foreign correspondents have even more complications of name and spelling than we Radiophans. Mail comes to the General Electric Company, Schenectady, New York, addressed to every word combination from Electric, New York to "The General" himself.

"KH" Is Graduate Musician

"This is WGY, Schenectady. One minute please." You know the voice. And above is Kolin Hager himself, director and chief announcer of WGY. His voice is well modulated. I was interested to find out what kind of training had produced a voice that gives WGY one of the best carrying qualities on the air.

"KH" as he is known, is a graduate musician, a singer, was overseas in the service and produced several musical comedies of soldier talent in France, and in addition is a trained public speaker. That is a combination which brings the excellent modulation for Radio. I watched him announce a number, I saw that his pause before each word was as studied as though the audience was seen. Probably greater care was taken than if the audience was before him to give added confidence. You see on the Radio, you are never quite sure how well your voice "gets over," while before visible audience, expressions tell tales of the interest.

WGY Drama Experiments

WGY has specialized on Radio plays, directed by KH. A censor with muffled ears to shut out all studio sounds, listens in to the Radio sounds of the play and catches the slightest errors of phrasing or voice inflection.

The WGY Players sometimes write their own plays. Many plays are written especially for them or are modified to suit the Radiophan needs. For instance, a play which depends upon sight for its climax is worthless in Radio. But the play which can carry emotion and implied

action by the speaking voice, is the Radio play at best.

The WGY dramatic stock company rehearses weekly and usually three rehearsals are given before appearing on the air. KH directs these and frequently plays leading parts. Other announcers, whose voices are schooled in the work, are recruited into the plays. They carry a repertoire of about ten plays.

Has Symphony Orchestra Too

A WGY symphony orchestra is a stock organization directed by Leo Klieven and Edward H. Smith. This orchestra plays regularly from WGY and rehearses as faithfully as its dramatic contemporaries.

Cities surrounding Schenectady are connected to the General Electric plant by remote telephone control, operative by direct telephone communication to the central broadcasting service. Church services are given in alternating cities. For instance, the Lutheran Church of Amsterdam, will be followed the next Sunday by the Presbyterian church of Saratoga Springs, broadcast direct from the churches themselves, and not merely studio chapel services.

Bank Puts on Program

On the evening that I visited WGY, the entire early program was given by the Commercial National Bank of Albany, twelve miles away. The orchestra, soloists and male quartet motored to the studio and gave their program while the officials, their employes and families listened in at Albany at their annual banquet. Then when the program was ended the musicians motored back to Albany and furnished dance music till the "wee small" hours. This bank has made a special effort toward employe welfare. Its recreation rooms are used as clubrooms and rehearsal studios for music and dramatic clubs of the bank.

By its system of remote control, WGY has broadcast affairs of public interest in all the surrounding territory. The New York inauguration (for the entrance of Al Smith into New York's gubernatorial chair was of national interest) was broadcast from Albany, and the Yale-Harvard game in detail from the field.

Travel Night Feature

KH has instituted an interesting form of travel night in which he features a country, its music and its characteristics as told by a native speaker and native

### SUMMER PHOTOGRAPHS? EARN A DOLLAR—

SUMMERTIME means summer pictures. You and your camera can earn a dollar by sending the Digest out-of-doors photos involving the use of Radio in camp, the automobile, swimming, boating, canoeing, on the hive, playing golf, etc. Send such photographs with negatives and a few descriptive words, including a stamped, addressed envelope so that unsuitable pictures may be returned.

SUMMER PHOTO DEPARTMENT, Radio Digest, 123 Madison St., Chicago.

"On my single tube portable set I have listened in to concerts from the following stations, which, I believe, break records as set forth in the June 30th Radio Digest. They are as follows:

WJAZ, WMAQ, Chicago; KSD, St. Louis; WHB, WDAF, Kansas City; WOAW, Omaha; WEAY, Houston, Tex.; WSB, Atlanta, Ga.; WOS, Jefferson City, Mo.; WCX, WWJ, Detroit."—Bill Mee, Oklahoma City, Okla.

"The best station record I have been able to make is KHJ, Los Angeles, Calif. I heard this on one tube using a portable set."—Foster McKenzie, Cleveland Heights, O.

"These stations have been received by myself with only a single tube set:

KFAF, Denver; WGAQ, Shreveport, La.; WNAC, Boston; WLAG, Minneapolis; WHB, WOQ, WDAF, Kansas City; WOS, Jefferson City, Mo.; WMAK, Lockport, N. Y.; WEAJ, New York City; WGY, Schenectady, N. Y.; WNAD, Norman, Okla.; WOO, Philadelphia; WAAK, WIAO, Milwaukee, Wis.; WBAP, Ft. Worth, Tex.; WEAY, Houston, Tex.; WOAI, San Antonio, Tex.; WOK, Pine Bluff, Ark.; KQV, Pittsburgh; WOI, Ames, Ia.; WGR, Buffalo, N. Y.; WBL, Anthony, Kans.; WQAM, Miami, Fla.; WFAA, WDAO, Dallas, Tex.; WAAP, Wichita, Kans.; WAAM, Newark, N. J.; W. O. A. W., Omaha, Nebr.; WHAZ, Troy, N. Y., and WKY, Oklahoma City, Okla."—William Cockrell, Swannanoa, N. C. (17 miles east of Asheville).

### Plan Largest Private Station

CHICAGO.—Station WTAS, owned and operated by Charles E. Erbstein at his country home, Villa Olivia, near Elgin, Ill., will be greatly enlarged and improved in the near future, so that it will become the largest privately owned station in the world, according to the plans of Mr. Erbstein.

### RECEIVING RECORDS? SEND 'EM IN—

(The following extracts are from letters of Radiophans, who have been doing good distance work. Readers submitting letters for publication should describe or diagram their sets.—DX Record Editor.)

## The New Grebe Broadcast Receiver

Point No. 4 YOU MAY RECEIVE all broadcasting with this Receiver—its range 200—600 metres covers the wavelengths of all broadcasting stations.

Just One of its Seven Points of Satisfaction

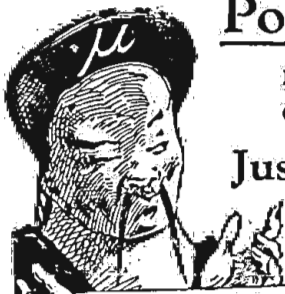

Licensed under Armstrong U. S. Pat. No. 1,113,149

Ask Your Dealer

A. H. GREBE & CO., Inc. Richmond Hill, N. Y.

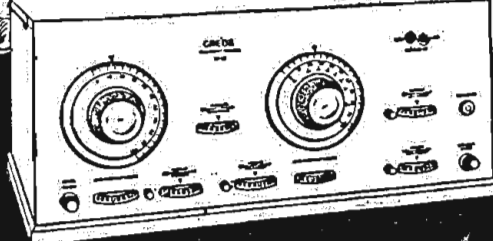

# SURVEYS INDUSTRY'S TANGLE OF PATENTS

## "Cooperative Competition" Leaves Maze of Stumbling Blocks for Independent Manufacturer

By John B. Brady

(Editor's Note.—Mr. Brady, a patent attorney of Radio repute, has achieved a remarkable survey of the network of patents, locking and interlocking the Radio industry in a veritable Gordian knot. His serial treatise on the patent situation started last issue.)

### PART II

THE Radio Corporation has also used a number of other defendants under the Langmuir grid leak patent 1,282,439 including the Radio Stores Corporation, the Sleeper Radio Corporation and John Firth & Co., Inc. These suits were brought in

Assembling Co., composed of Harriettes, Wolfe, Jr., Jolly et al., and secured a temporary injunction under the adjudicated Armstrong patent effective upon filing security.

With all of these suits against small manufacturers or their distributors the independents may well view with alarm the aggressive patent policy of the Radio Corporation which is slowly but surely tending to drive competitors out of the industry.

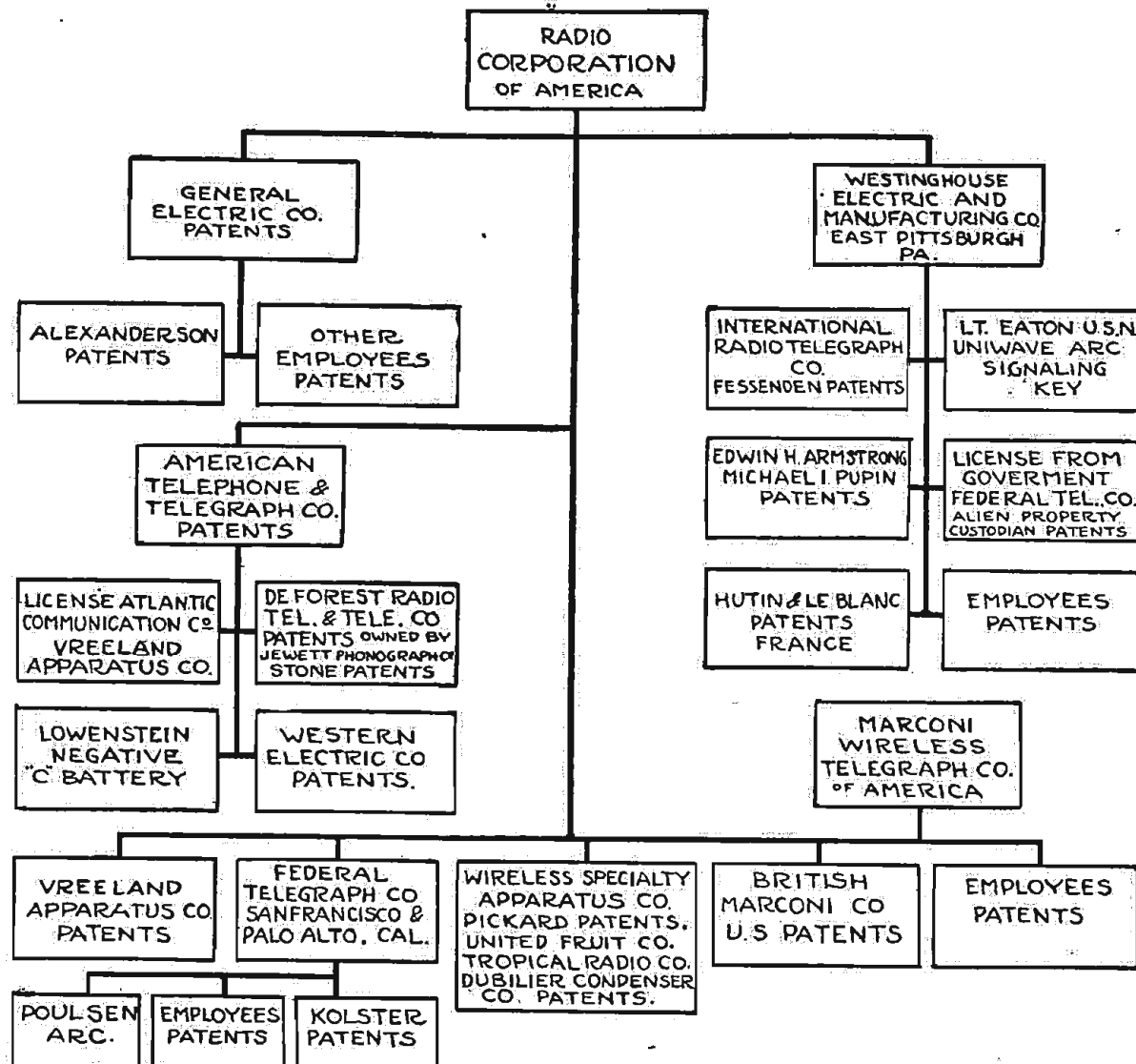

Radio Patent Organization Chart

the United States District Court for the Southern District of New York.

The Westinghouse Company, also a part of the Radio Corporation, sued in the name of Edwin H. Armstrong in the United States District Court for the Southern District of New York under the Armstrong regenerative circuit patents 1,113,149, the Radio Guild Co., Inc., and the Standard

How R. C. A. Formed Monopoly  
How was the Radio Corporation patent monopoly formed?

## AUXILIARY TUNER

THIS new instrument connected to your present receiving set with one wire enables you to easily bring in both the long and short wave stations which you cannot get with your present equipment. It also enables you to eliminate that local interference so you may listen to distant stations.

Copyrighted diagram and complete instructions for building and operating this instrument \$1.00, or with all parts, including Condenser, Coils, Switches, Panel and Cabinet, \$10.00. Complete instrument, \$15.00. All goods prepaid.

S. A. TWITCHELL

1925 Western Avenue, Minneapolis, Minn.

When the United States entered the war the commercial companies foresaw that the Government would require patriotic co-operation and large quantities of Radio apparatus for the army, navy and coast guard. The American Telephone and Telegraph Company and Western Electric Company entered the Radio field on a large scale only by securing a patent situation under contract with the De Forest Radio Telephone and Telegraph Company in which they secured certain rights under the important three electrode electron tube patent and the De Forest amplifier patent, among the various others. They purchased the Lowenstein invention of the negative C battery for biasing the grid of the electron tube, a patent particularly important in tube transmitters.

### Licenses Secured

A license was secured under patents of the Atlantic Communication Company and the Vreeland Apparatus Company. The General Electric Company was developing a Radio patent situation upon the inventions of Langmuir, Alexanderson, Coolidge and others. The Marconi Company had continued to build its patent situation, utilizing among others the invention of Weagant on various circuits and of Hill and Clark on the wave changer construction used in quenched gap ship transmitters in the navy.

The Federal Telegraph Company had assigned to the government its patents controlling the manufacture and operation of high power arc transmitters including among others, the inventions of Pederson, Poulsen, Schou, Fuller, Marx, Rodman, Watkins, and Beal. The Westinghouse Electric and Manufacturing Company were becoming interested in the manufacture of Radio equipment for the government.

The patent situation was such that manufacturers would not accept orders for Radio apparatus unless the purchaser agreed to hold the manufacturer harmless from any damage arising out of the infringement of patents. The government as a war emergency requiring Radio apparatus as a vital necessity, agreed to save the producer harmless from infringement of patents and, therefore, with the co-operation of all, a large production program ensued and the government secured the much needed Radio equipment for the successful prosecution of the war.

(TO BE CONTINUED)

Broadcasts Another Beauty Talk  
COLUMBUS, O.—The second of a series of physical education lessons by Radio was given recently by Station WPAL, the Superior Radio & Telephone Equipment Company here.

# SYMPHONY RECEIVER, 3 STAGE AMPLIFIER

## HOW TO OPERATE UNITS CLEARLY EXPLAINED

This Single Circuit Tuner, with Regenerative Feedback System Gives Unusual Selectivity

See Photo Diagram On Facing Page

The standard receiving set illustrated on page seven is a Symphony No. 503 detector and three stage audio frequency amplifier, manufactured by the Jones Radio Co. of Chicago, Illinois. A single circuit hook-up, comprising a tapped inductance and variable condenser in series is used. The tapped inductance is made up of the stator winding of a variocoupler and a diamond-wound coil mounted on the stator shell for building up the required inductance. The rotor of the variocoupler provides the regenerative feature, since it is connected in series in the plate circuit.

(Continued on page 13)

## Amrad Two Stage Amplifier

Complete in mahogany cabinet. Wonder-ful buy, \$40.00 value. Limited quantity. **\$17.95**

- |   |                   |
|---|-------------------|
| 25.00 Amrad Portable Set.....   | Our Price \$22.75 |
| 40.00 Amrad Reflex Set No. 3386.....  | 34.98             |
| 20.00 CROSLLEY V. ONE TUBE SET.....   | 17.95             |
| 42.25 Erls Reflex Circuit. Complete parts to build this set, including diagram..... | 27.95             |
| 2.00 Filkoostat.....  | 1.80              |
| 1.00 25 Ohm Rheostat.....   | .85               |
| .50 2" Dial.....  | .19               |
| .50 Fada Switch Lever.....  | .18               |
| 25.00 DX Crystal Set, complete with Phones, ready to "listen in".....               | 8.95              |
| 2.00 Gold Grain Detector (Panel Mtg.).....  | 1.89              |
| 2.50 Gold Grain Detector (Base Mtg.).....   | 1.39              |
| 1.00 Variable Grid Leak (0-5).....  | .39               |
| 2.50 11 Plate Variable Condenser.....   | 1.16              |
| 3.50 23 Plate Variable Condenser.....   | 1.29              |
| 5.00 43 Plate Variable Condenser.....   | 1.68              |
| .25 Spaghettil, 3 ft. (any color).....  | .08               |
| 1.00 Rheostat.....  | .45               |
| 11.50 U. S. NAVY TUBE.....  | 4.95              |
| 6.50 Turney Spider Web Coils and Mtg.....   | 3.95              |
| 3.00 Brach Lightning Arrestor.....  | 1.65              |
| 1.25 Univermier with Dial (Splithair adj.).....                                     | 1.08              |
| 3.50 Lefax Radio Handbook.....  | 2.98              |
| 12.00 NATHANIEL BALDWIN PHONES (MICA DIAPHRAGM).....                                | 8.35              |
| 6.50 WD-11 TUBES.....   | 5.45              |

Everything guaranteed as firsts. Send for Special Price List. We pay the postage.  
**RADIO SUPPLY STORES**  
254 West Stiegel Street, Mannheim, Pa.

## SPECIAL SUMMER SAVING!

### On Type 400 MELCO RECEIVER

at distributor's **\$17.50** price of only...

Regular List Price \$35

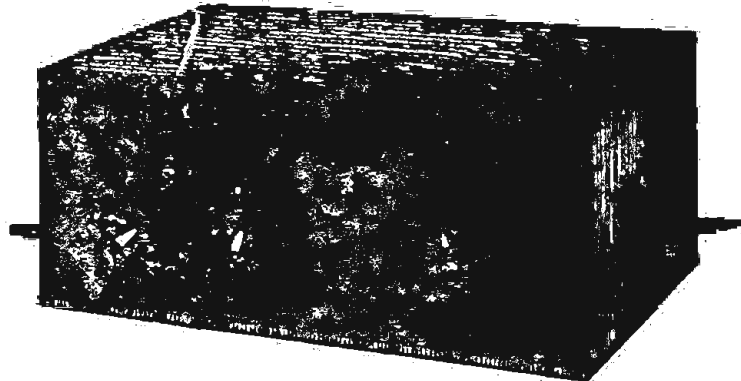

Two-stage amplifying unit for use with the Melco-400, also regularly costing \$35, now only **\$17.50**

The Melco Type 400 Radio Receiver covers all broadcasting ranges thoroughly from 165 to 600 meters and assures a great degree of selectivity on the average small outdoor aerial. The Melco is the ideal summer set because it is least affected by electrical disturbances. Sold with our absolute money-back guarantee. Shipped immediately on receipt of purchase price—F. O. B. N. Y.

WRITE FOR DESCRIPTIVE BOOKLET

**AMSCO PRODUCTS, Inc.**

Fairbanks Building

Boorme & Lafayette St.

New York City

## "MAKE PERFECTION YOUR SELECTION"

PHONES	List Price	Our Price	MISCELLANEOUS	List Price	Our Price
ACME—has no peer for receiving clear	\$ 8.00	\$3.95	Tungar 5 Amp.....	\$28.00	\$22.50
Western Electric.....	12.00	7.95	Tungar 2 Amp.....	18.00	14.95
N. & K., 5000 Ohms.....	16.00	6.50	Mica Diaphragms.....	2.00	1.25
Rico, 3000 Ohms.....	6.50	3.95	<b>RHEOSTATS</b>		
Dictagraph, 3000 Ohms.....	8.00	6.50	Cutler Hammer.....		.85
Ambassador, 3000 Ohms.....	3.98		With Vernier.....		1.25
Nathaniel Baldwin, Original.....	12.00	8.75	C. H. Potentiometer.....		1.25
Nathaniel Baldwin, Single, with Cord.....	6.00	4.45	Klosner Vernier.....		1.20
<b>VARIOCOUPERS &amp; VARIOMETERS</b>			<b>SETS</b>		
Queens.....	5.00	1.95	Aeriola Jr.....	18.00	5.95
Fisher.....	5.00	1.95	Cutting & Washington 3-Tube Type 11.....	125.00	55.00
Raven.....	6.00	2.95	Tuska Regenerative.....	35.00	22.50
Tuska with Dial.....	6.00	2.95	Crosley Regenerative.....		19.00
Pathe.....	6.00	2.95	Crosley 2-Step Amplifier.....		17.00
Columbia.....	6.50	3.95	2-Step Amplifier, Assembled.....		11.95
Workrite.....	6.00	2.95	General Radio 1-Step Amplifier.....	8.00	6.95
Eagle Bakelite.....	8.50	4.95	<b>LOUD SPEAKERS</b>		
Fisher, Large.....	6.50	2.95	Magnavox Type R3.....	35.00	24.95
Poarlco Bakelite.....	6.50	4.45	Atlas.....	25.00	17.50
<b>VARIABLE CONDENSERS</b>			Western Electric.....	55.00	Special
3 Plate.....	2.00	1.25	Music Master.....	30.00	24.95
11 Plate.....	3.50	1.75	Wooden Horn.....	8.50	5.75
17 Plate.....	4.00	1.95	Aluminum Horn.....	10.00	4.95
23 Plate.....	4.00	1.95	<b>TUBES</b>		
43 Plate.....	5.00	2.25	UV-199, UV-201-A, WD-12, WD-11, All Genuine.....		5.75
11 Plate Vernier.....	6.00	3.25	VT-2 Western Electric.....		7.95
17 Plate Vernier.....	6.00	3.25	De Forest UD-6.....		3.75
23 Plate Vernier.....	6.60	3.50	UV-200.....		4.50
43 Plate Vernier.....	7.50	3.95	<b>COMPLETE PARTS FOR</b>		
<b>TRANSFORMERS</b>			Flawelling Circuit.....		13.95
All American.....		3.95	Reinartz Circuit.....		11.95
Erla Reflex.....		4.50	Neurodyne Circuit.....		35.00
Thoradson.....		2.95	Cockaday.....		13.95
Acme Audio or Radio.....		3.75	2-Step Amplifier.....		9.95
Tri-Coil Radio.....		1.50			

PERFECTION RADIO CORPORATION,  
Six New York Retail Stores

Add Parcel Post

59 Cortland St., NEW YORK CITY  
Do Not Send Stamps

# The New Grebe Broadcast Receiver

Point No. 5 A TUNING DIAL, graduated in wavelengths, enables you to locate, instantly, the station you desire.

Just One of its Seven Points of Satisfaction

Licensed under Armstrong U. S. Pat. No. 1,113,149

Ask Your Dealer

A. H. GREBE & CO., Inc.  
Richmond Hill, N. Y.

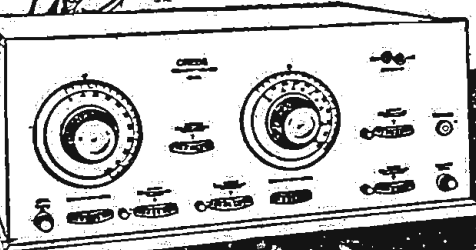

# Radio Receiving Sets

## The Symphony Receiver and Amplifier

As another of the series of standard receiving sets, Radio Digest presents herewith the photo diagram of the Symphony No. 503 detector and three stage audio frequency amplifier, manufactured by the Jones Radio Co. of Chicago, Illinois. This receiver combines a single circuit hook-up with a variometer connected between the aerial and plate circuit. A tapped inductance is connected in series with an antenna tuning condenser. These two work-

ing in conjunction enable the operator to select the proper values of inductance and capacity. As a result, selective tuning is unusually efficient. Naturally this type of hook-up makes the circuit regenerative, licensed under Armstrong patent 1,113,149. Operating instructions and description will be found on page six. Although the reader may not own a Symphony, points of similarity in standard receivers will repay him for studying the diagram.

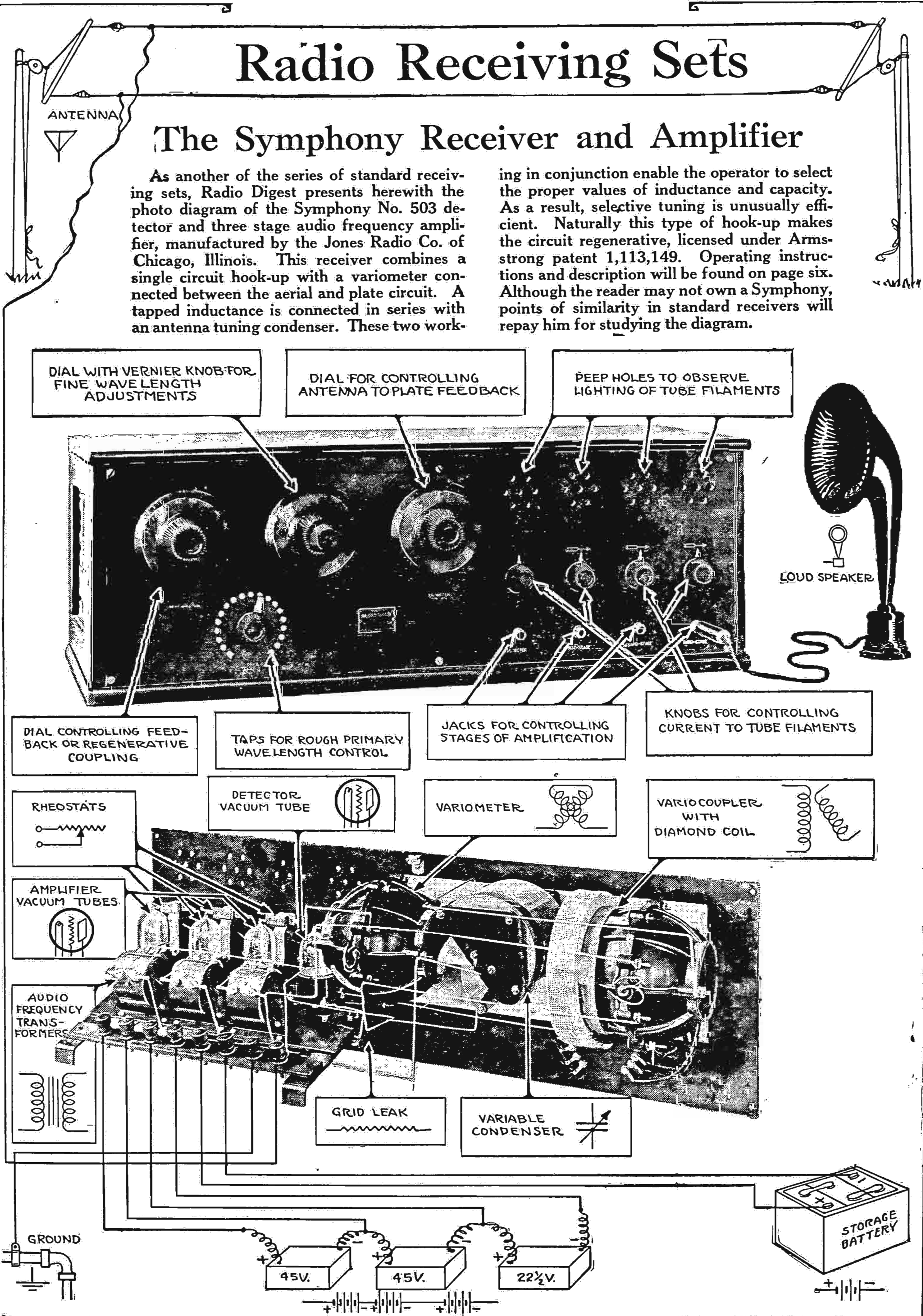



# Radiophone Broadcasting Stations

## Corrected Every Week—Part I

AA3, Denver, Colo. 440 meters. 1,500 ml. Fitzsimons Gen. Hospital. (Educational Dept. U. S. Army). Fri, 8-9 pm, music, entertainment. Mountain.

AQ6, Canton, O. 425 meters. 500 ml. Hdqrs. 135th Field Artillery O. N. G. Wed, Fri, music. Sun, church services. Eastern.

AS6, San Antonio, Tex. 360 meters. 200 ml. U. S. Army. Ft. Sam Houston. Mon, Thurs, irregular.

AV7, St. Paul, Minn. 400 meters. 500 ml. 6th Inf. Minn. Nat'l Guard, St. Paul Armory. Daily ex Sun, 2-2:30 pm, music, announcements. Tues, 8:30-10 pm, Thurs, 8:30-9:15 pm. Central.

BE1, Tacoma, Wash. 400 meters. 100 ml. Camp Lewis, U. S. Army, Third Signal Co. Daily ex Thurs, Sun, 6-7 pm, music, announcements, lectures. Pacific.

CFAC, Calgary, Alta., Can. 430 meters. 1,000 ml. Calgary Daily Herald. Daily ex Sun, 12:30-1 pm, 3-4. Daily, 7:45-8:45 pm. Mountain.

CFCA, Toronto, Ont., Can. 400 meters. 500 ml. Toronto Star. Daily ex Sun, 12 m, weather; 2:30-3:30 pm, news, music; 5:30-6, news; 8-9, concert. Sun, 8:45 pm, concert. Eastern Daylight Saving.

CFGB, Vancouver, B. C., Can. 440 meters. 1,500 ml. Vancouver Daily Province. Daily, 8:30-9:30 pm, reports, news, music. Pacific.

CFGE, Halifax, N. S., Can. 440 meters. 150 ml. Marconi Co. Mon, Wed, Sun night, music, entertainment. Eastern.

CFGF, Montreal, P. Q., Can. 440 meters. 1,000 ml. Marconi Co. Daily ex Sun, 1-1:30 pm. Monday, Wed, Fri, 7:30-9 pm. Eastern.

CFCH, Iroquois Falls, Ont., Can. 400 meters. 200 ml. Abidini Power & Paper Co. Ltd. Daily, 8 pm, weather and stock reports. Experimental station. Eastern.

CFCK, Edmonton, Alta., Can. 410 meters. Radio Supply Co. Daily ex Sun, 8-8:30 pm, music. Sun, 3:30-4:30 pm, Concert. Mountain.

CFCN, Calgary, Alta., Can. 275, 440 meters. 1,500 ml. W. W. Grant Radio Ltd. Slogan, "Voice of the Prairies." Mon, 9 pm, music. Fri, 10:30-12:30 pm, dance music. Sat, 10-12 pm. Wed, Sat, Sun, after 11:30 pm using test call 9AC. Mountain.

CFCL, London, Ont., Can. The London Advertiser.

CFCC, Fort Frances, Ont., Can. International Radio Develop. Co.

CFTC, Toronto, Ont., Can. The Bell Telephone Co. Licensed only.

CFVC, Vancouver, B. C., Can. Victor Wentworth Odium.

CHBC, Calgary, Alta., Can. 410 meters. 1,000 ml. W. W. Grant Radio Ltd. (Morning Albertan.) Daily ex Sat, 8:45-9:45 pm, news, stock quotations, music. Mountain.

CHCA, Vancouver, B. C., Can. Radio Corp. of Vancouver, Ltd.

CHCB, Toronto, Can. Marconi Co. No regular program.

CHCF, Winnipeg, Man., Can. Radio Corp. of Winnipeg, Ltd.

CHCS, London, Ont., Can. London Radio Shoppe.

CHCX, Montreal, Que., Can. B. L. Silver.

CHYC, Montreal, Que., Can. 410 meters. 1,500 ml. Northern Elec. Co. No regular schedule.

CHXC, Ottawa, Ont., Can. 450 meters. 50 ml. J. R. Booth, Jr. Mon, Wed, 8:30-11 pm, music, entertainment. Eastern.

CIBC, Montreal, Que., Can. 420 meters. 75 ml. Dupuis-Freres. Wed, Fri, 9-10 pm, music. Eastern.

CJCA, Edmonton, Alta., Can. 450 meters. 1,000 ml. Edmonton Journal, Ltd. Slogan, "The Sunniest Spot in Sunny Alberta." Club, "1500 Hut." Daily ex Sun, 12:30 pm, weather, markets; 7:30-8 pm, Children's hour; 8:30-9:30 pm, concert, reports. Tues, 11-12 pm, Club. Mountain.

CJCB, Nelson, B. C., Can. 400 meters. 100 ml. James Gordon Bennett. Daily, 8-9 pm, music, news, reports. Pacific.

CJCD, Toronto, Canada. 410 meters. 200 ml. T. Eaton Co. No regular program.

CJCE, Vancouver, B. C., Can. 420 meters. 150 ml. Vancouver Sun. Daily ex Sun, 8-10, music, news. Pacific.

CJCH, Toronto, Ont., Can. United Farmers of Ontario.

CJCI, St. John, N. B., Can. 400 meters. 75 ml. McLean, Holt & Co., Ltd. Mon, Wed, Fri, 7:30-9 pm, music. Eastern.

CJCN, Toronto, Ont., Can. Simons, Agnew & Co. Licensed only.

CJCS, Halifax, N. S., Can. Eastern Telephone & Telegraph Co.

CJCK, Olds, Alta., Can. 400 meters. 1,500 ml. Percival W. Shackleton. Tues, Thurs, 9:45-11 pm, music. Sat, 8:45-10 pm, music. Mountain.

CJCY, Calgary, Alta., Can. Edmund Taylor.

CJGC, London, Ont., Can. 430 meters. 800 ml. London Free Press. Daily ex Sun, 12:30-1:30 pm, news, weather. Daily ex Tues, 7-7:45 pm, music. Tues, 7:30-8:30 pm, special program. Eastern.

CJNC, Winnipeg, Man., Can. 400 meters. 1,000 ml. Tribune Newspaper Co. Daily ex Sun, 1-2 pm, Tues, 8-10 pm, Thurs, 7-8 pm, Fri, 8-10. Alternate Sun, 8:30-10 pm. Central.

CJSC, Toronto, Ont., Can. Evening Telegram. Licensed only.

CKAC, Montreal, Que., Can. 430 meters. 1,000 ml. La Presse. Daily ex Sun, 2 pm, 3:30, weather, news, markets. 5-5:15, music. Tues, Thurs, Sat, 7-7:30 pm, bedtime stories; 7:30-10 concert, Sun 4-5:30 pm, music. Eastern.

CKCB, Winnipeg, Man., Can. T. Eaton Co. Ltd.

CKCE, Toronto, Ont., Can. Can. Ind. Telephone Co.

CKCK, Regina, Sask., Can. 420 meters. 1,500 ml. Leader Pub. Co. Daily ex Sun, 10-10:30 am, news, music; 1:15-2 pm, reports, music. Mon, Wed, Fri, Sat, 7:30-8:15, music. Tues, 7:30-9 concert. Sun, 9 pm, sacred concert. Mountain.

CKCR, St. John, N. B., Can. 400 meters. 75 ml. Jones Elec. Radio Co., Ltd. Daily 4-5 pm, concert, reports. Eastern.

CKKC, Toronto, Ont., Can. Radio Equipment & Supply Co., Ltd. Licensed only.

CKOC, Hamilton, Ont., Can. 410 meters. 100 ml. Wentworth Radio Supply Co., Ltd. Mon, Wed, Fri, 8:30-9:30 pm, concert. Sun, church services. Eastern.

CKOQ, London, Ont., Can. 410 meters. 50 ml. Radio Supply Co. Mon, Wed, Fri, 7:30-8:30 pm, music, entertainment. Eastern.

CKY, Winnipeg, Man., Can. 450 meters. 500 ml. Manitoba Tel. Co. Daily ex Sun, 12:30-1:45 pm, news, markets, music; 1:45-2:00 pm. Tues, Thurs, Fri, 8:30-10 pm, concert. Sun, 9-9:45 pm, concert.

CKZC, Winnipeg, Man., Can. Salton Radio Eng. Co. DN4, Denver, Colo. 360 meters. 200 ml. Colorado National Guard. Daily ex Sun, 8:15 pm, weather, news, concert. Thurs, 8:15-9:30 pm, special concert, speech. Mountain.

KDKA, E. Pittsburgh, Pa. 326 meters. 2,000 ml. Westinghouse Elec. & Mfg. Co. Daily ex Sun, 10-10:15 am, 12:30-1 pm, music; 6-9:55 pm, news features, markets, concert; 9:55-10, time. Sun, 10:45 am, church service; 2:45 pm, Bible story; 3 pm, concert; 4:45 pm, 7:30, church service. Eastern.

KDOW, New York, N. Y. S. S. America. Home port in New York.

KDPM, Cleveland, O. 270 meters. Westinghouse Elec. & Mfg. Co.

KDPT, San Diego, Calif. 360 meters. 500 ml. Southern Elec. Co. Daily ex Sun, 7-7:30 pm, news, weather, concerts, lecture. Tues, Sat, 8-10 pm. Sun, 11:30-12:00 am, sermon. Pacific.

KDYL, Salt Lake City, Utah. 360 meters. 1,800 ml. Salt Lake Telegram. Daily ex Sun, 7-8 pm, news, music, entertainment. Mountain.

KDYM, San Diego, Calif. 252 meters. Savoy Theater.

KDYW, Portland, Ore. 360 meters. 200 ml. Oregon Institute of Technology. Temporarily discontinued.

KDYS, Great Falls, Mont. 360 meters. 1,000 ml. Great Falls Tribune. Mon, Wed, Sat, 8-10 pm, concert. Sun, 4 pm, church services. Mountain.

KDYW, Phoenix, Ariz. 360 meters. 100 ml. Smith Hughes & Co. Temporarily discontinued.

KDYX, Honolulu, T. H. Hawaii. 360 meters. 500 ml. Honolulu Star-Bulletin Co., Ltd. Daily ex Sun, 12:15-1:15 pm, reports; 6:30-7:30 pm, entertainment, music, talks. Sun, 11 am-12:15 pm, church services. 120th Meridian.

KDZB, Bakersfield, Calif. 360 meters. 500 ml. Frank Siefert. Daily ex Sun, 8-9 pm, reports, music. Sun, sacred program, irregular. Pacific.

KDZE, Seattle, Wash. 360 meters. 500 ml. Seattle Radio Assn. Daily ex Sun, 10:30-11 am, 3:30-4:30 pm, news, music. Mon, Fri, 7-8 pm, concert. Wed, 8-9 pm, concert. Pacific.

KDZF, Los Angeles, Calif. 278 meters. Automobile

Club of Southern California.

KDZI, Wenatchee, Wash. 360 meters. 700 ml. Elec. Supply Co. Daily ex Sun, 4:30-5:30 pm, music. Mon, Wed, Fri, 8-9 pm, music. Sun, 11 am-12:30 pm, church services. Pacific.

KDZK, Reno, Nev. 360 meters. 50 ml. Nevada Machine & Elec. Co. (Nevada State Journal). Sun, 7-8 pm. Pacific.

KDZZ, Denver, Colo. 360 meters. Pyle & Nichols.

KDZR, Bellingham, Wash. 261 meters. 200 ml. The Bellingham Pub. Co. Mon, Wed, Fri, 7-8:30 pm, music, news, reports; 7:30-7:45, code practice. Tues, Sat, Sun, 7-8 pm. Pacific.

KDZT, Seattle, Wash. 360 meters. Seattle Radio Assn. KFAD, Phoenix, Ariz. 360 meters. 200 ml. McArthur Brothers. Daily ex Sun, 7:30-8:30 pm, news, weather, stock reports. Mountain.

KFAE, Pullman, Wash. 360 meters. 1,500 ml. State College of Washington. Mon, Wed, Fri, 7:30-9 pm, lectures, music, readings. Pacific.

KFAF, Denver, Colo. 360 meters. 1,500 ml. Western Radio Corp. Slogan, "Voice from the Rockies—Out Where the West Is." Daily ex Wed and Sun, 8-9 pm, music, reports, news. Mountain.

KFAJ, Boulder, Colo. 360 meters. 800 ml. Univ. of Colo. No definite schedule. Univ. activities. Mountain.

KFAN, Moscow, Ida. 360 meters. 200 ml. The Electric Shop. Tues, Thurs, Sat, 7:30-8:30 pm, music, reports. Sun, church services. Pacific.

KFAP, Butte, Mont. 360 meters. Standard Pub. Co. KFAR, San Jose, Calif. 360 meters. City of San Jose.

KFAS, Hollywood, Calif. 280 meters. Studio Lighting Service Co.

KFAT, Eugene, Ore. 275 meters. 100 ml. Pac. Radio Co. Mon, Wed, Sat, 8-9 pm, lectures, music. Pacific.

KFAU, Boise, Ida. 270 meters. 200 ml. Boise H. S. Daily ex Sun, 3-3:30 pm, markets, news; 8:30 pm, weather. Tues, Fri, 8-9 pm, concert. Thurs, 7:30-8:15 pm, music. Mountain.

KFAV, Venice, Calif. 258 meters. 50 ml. Abbot-Kinney Co. Mon, Tues, Wed, Fri, 8:30-9:30 pm, music. Pacific.

KFAW, Santa Ana, Calif. 360 meters. 100 ml. Radio Den. Daily ex Sun, 4:4-3:30 pm, news, reports, music. Mon, Thurs, 6:30-7:30 pm, concert. Pacific.

KFAY, Medford, Ore. 360 meters. 500 ml. Virgin Radio Service. Temporarily discontinued.

KFBB, Havre, Mont. 360 meters. 150 ml. F. A. Buttery Co. Daily ex Sun, 12:30 pm, agriograms, weather, news. Tues, Fri, 8-9:30 pm, music. Mountain.

KFDQ, Bozeman, Mont. 360 meters. H. Everett Cutting.

KFDL, Des Moines, Iowa. 278 meters. 300 ml. Hawk-eye Radio & Supply Co. Daily ex Sun, 3-3:45 pm, reports, music. Mon, 9-11 pm, music. Thurs, 9-11 pm, music, entertainment. Central.

KFDR, York, Neb. 360 meters. Bullock's.

KFDS, San Francisco, Calif. 360 meters. John D. McKee.

KFDU, Lincoln, Neb. 240 meters. Neb. Radio Elec. Co.

KFDV, Fayetteville, Ark. 360 meters. 300 ml. Gilbrech & Stinson. Slogan, "Southern Gateway to the Ozarks." No regular schedule. Central.

KFDX, Shreveport, La. 360 meters. First Baptist Church.

KFED, Brookings, S. D. 360 meters. S. D. State College of Agri. & Mech. Arts. Mon, Sat, 8:30 pm, music. Tues, Thurs, 11 am, music, lectures, news. Central.

KFDZ, Minneapolis, Minn. 360 meters. Harry O. Iverson.

KFEC, Portland, Ore. 360 meters. 75 ml. Meier & Frank Co. Inc. Daily ex Sun, 12 m, weather, reports; 4-5 pm, music; 6:30 pm, weather, crop, markets, reports. Thurs, 9-10 pm, concert. Sat, 11 am 12 m, children's hour. Pacific.

KFEJ, Tacoma, Wash. 360 meters. Guy Gresson.

KFEL, Denver, Colo. 360 meters. Winner Radio Corp. Daily ex Sun, 9 am, 10, 11, 11:45, stock reports; 3-4 pm, music. Mon, Fri, 9-10 pm, 12-1 am, concerts. Sun, 9-10 am, church services. Mountain.

KFEP, Denver, Colo. 240 meters. Radio Equipment Co.

KFEQ, Oak, Neb. 360 meters. J. L. Scroggin.

KFER, Fort Dodge, Ia. 231 meters. Auto Electric Service Co.

KFEV, Douglas, Wyo. 263 meters. 250 ml. Felix Thompson Radio Elec. Shop. Weather reports and special warnings. Mountain.

KFEW, Minneapolis, Minn. 275 meters. 600 ml. Augsburg Seminary. Mon, Wed, Fri, 10:30 am, chapel. Tues, Sat, 6 pm, music. Sun, 9:15 pm, church services. Central.

KFEY, Kellogg, Ida. 360 meters. Bunker Hill & Sullivan Mining & Const. Co.

KFEZ, St. Louis, Mo. 360 meters. American Society of Mech. Engrs.

KFFA, San Diego, Calif. 244 meters. 200 ml. Dr. R. O. Shelton. Daily, 6-7 pm, entertainment. Pacific.

KFFB, Boise, Ida. 273 meters. 70 ml. Jenkins Furn. Co. (Owyhee Hotel). Daily, 8-9 pm, concert. Mountain.

KFHP, Kearney, Neb. 246 meters. Radio Bug Products Co.

KFHQ, Los Angeles, Calif. 242 meters. Curtis Bros. Hiwa. Store.

KFHR, Seattle, Wash. 270 meters. Star Elec. & Radio Co.

KFHV, Mayville, N. D. 261 meters. M. G. Satoron.

KFHY, Trinidad, Colo. 242 meters. R. S. McEwan.

KFI, Los Angeles, Calif. 469 meters. 2,000 ml. Earl C. Anthony, Inc. Daily ex Sun, 5-6 pm, 6:45-7:30 pm. 8-11 pm, Wed, Fri, Sat, 8-12 pm. Sun, 10:30-11:30 am, 4-5 pm, 8-11. Pacific.

KFIB, St. Louis, Mo. 244 meters. Franklin W. Jenkins.

KFIC, Denver, Colo. 224 meters. Phillip Laskowitz.

KFID, Iola, Kans. 246 meters. Ross Arbuckles Garage. Daily, 5:15-5:45 pm. Mon, Thurs, Sat, 7:30-8 pm. Tues, Sat, 9-10 pm. Central.

KFIF, Portland, Ore. 360 meters. Benson Tech. Student Body.

KFIJ, Platte, S. D. 236 meters. Sidney J. Thorean.

KFIK, Gladbrook, Iowa. 234 meters. Gladbrook Elec. Co.

KFIL, Louisburg, Kans. 234 meters. Windisch Elec. Farm Equip. Co.

KFIO, Spokane, Wash. 252 meters. North Central High School.

KFIQ, Yakima, Wash. 224 meters. 200 ml. Yakima Valley Broadcasting Assn. Slogan, "The Station That Will Make 24 Famous." Daily ex Sun, 7:30-8 pm, weather, markets. Mon, Fri, 8-9 pm, concert. Pacific.

KFIU, Juneau, Alaska. 226 meters. Alaska Elec. Light & Power Co.

KFIV, Pittsburg, Kans. 240 meters. V. H. Broyles.

KFJA, Grand Island, Nebr. 244 meters. Central Power Co.

KFJB, Marshalltown, Iowa. 248 meters. Marshall Elec. Co.

KFJD, Greeley, Colo. 236 meters. 300 ml. Weld County Printing & Pub. Co.

KFKA, Greeley, Colo. 248 meters. Colorado State Teachers College.

KFKH, Ames, Colo. 226 meters. Denver Park Amusement Co.

KFLE, Denver, Colo. 268 meters. National Educational Service.

KFZ, Spokane, Wash. 283 meters. 300 ml. Doerr-Mitchell Elec. Co. Slogan, "In the Heart of the Inland Empire." Tues, Fri, 7:30-9 pm, music. Sun, 6-7 pm. Pacific.

KGB, Tacoma, Wash. 360 meters. 200 ml. Tacoma Daily Ledger—William A. Mullins Elec. Co. Daily ex Sun, 7-9 pm, Sun, 5-7:30 pm, entertainment. Pacific.

KGG, Portland, Ore. 360 meters. 500 ml. Hallock & Watson Radio Service. Slogan, "The Rose City." Daily ex Sun, 5-6 pm, music, entertainment 7:30-8 pm, reports. Sat, 8-9 pm, answers to Radio questions. Sun, Wed, 9-10 pm, music. Pacific.

KGN, Portland, Ore. 360 meters. 100 ml. Northwest Radio Mfg. Co. Irregular schedule.

KGO, Altadena, Calif. 360 meters. 300 ml. Altadena Radio Club. No regular schedule.

KGU, Honolulu, Hawaii. 360 meters. 150 ml. The Honolulu Advertiser. Daily, 7:30-9 pm. Tues, Thurs, Sat, special program. 150th meridian. (Three hours later than Pacific.)

KGW, Portland, Ore. 492 meters. 1,500 ml. Oregonian Pub. Co. Slogan, "KGW, Keep Growing Wiser." Daily ex Sun, 11:30 am, weather; 3:30-4 pm, woman's program; 7:30 pm, weather, 10-11 pm, music. Mon, Wed, Fri, 8-9 pm, concert. Mon, Fri, 7-7:30 pm, lecture; 11-12 pm, Hoot Owls. Sun, 7-8 pm, concert. Pacific.

KGY, Lacey, Wash. 258 meters. 250 ml. St. Martins College. Slogan, "Out Where the Cedars Meet the Sea." Tues, Fri, Sun, 8:30-9:30 pm, news, concert, lecture, bedtime story. Pacific.

KHJ, Los Angeles, Calif. 395 meters. 2,030 ml. Los Angeles Times. Daily ex Sun, 12:30-1:15 pm, 6:45-7:30, 8-10, Sun, 10-11 am, 8-10 pm. Pacific.

KHQ, Seattle, Wash. 360 meters. Louis Wasmer.

KIJ, Stockton, Calif. 360 meters. 100 ml. Gould, The Light Man. Daily ex Sun, 5-6 pm, concert. Mon, Wed, 9-10 pm, concert. Sun, 10-11 am, church services. Pacific.

KJR, Seattle, Wash. 270 meters. 1,500 ml. Northwest Radio Service Co. Daily ex Sun, 5:30-6:15 pm, reports. Mon, 7:30-8:30 pm, music. Tues, Fri, Sat, 8:30-9:30 pm, concerts, lecture, bedtime stories. Thurs, 9-10:30 pm. Pacific.

KJS, Los Angeles, Calif. 360 meters. 100 ml. Bible Inst. of Los Angeles. Tues, 7-7:30 pm, Thurs, 8-9, sacred music, lectures, etc. Sun, 11:30-12:30 pm, 6-6:45, 8-9, church services. Pacific.

KLN, Del Monte, Calif. 261 meters. Monterey Elec. Shop. Daily, 12-1 pm, weather, markets, news; 7-3 pm, concert. Tues, Fri, 7-7:30 pm, 8-8:30, concert. Pacific.

KLS, Oakland, Calif. 360 meters. 1,500 ml. Warner Bros. Radio Supply Co. Daily, 11:30-1 pm. Fri, 8-9 pm. Sun, 12-1 pm. Pacific.

KLX, Oakland, Calif. 360 meters. 500 ml. Oakland Tribune. Daily ex Sun, 3:15-5:15 pm, sports; 7-7:30, news, entertainment. Tues, 8-9 pm. Fri, 9-10 pm. Sun, 10-11 am, church services. Pacific.

KLZ, Denver, Colo. 360 meters. 200 ml. Reynolds Radio Co. Daily ex Sun, 7:30-8 pm, news, markets, bedtime story. Thurs, 8-9 pm, concert. Sun, 8:30-10:30 pm, concert. Mountain.

KMJ, Fresno, Calif. 360 meters. 300 ml. San Joaquin Lt. & Pr. Corp. Sun, 8-10 pm, music. Pacific.

KMO, Tacoma, Wash. 360 meters. 200 ml. Tacoma Times. (Love Electric Co.) Daily ex Sun, 6-7 pm, 9:15-10, concert, news, lecture. Pacific.

KNT, Aberdeen, Wash. 263 meters. 600 ml. Grays Harbor Radio Co. Daily ex Sun, 7-8 pm, news, concert. Pacific.

KV, Los Angeles, Calif. 360 meters. Radio Supply Co.

KNX, Los Angeles, Calif. 360 meters. Elec. Lighting & Supply Co.

KOB, Santa College, N. M. 360 meters. 500 ml. N. M. Agri. & Mech. Arts. Daily 11:55-12 m, 9:55-10 pm, time, reports. Mon, Wed, Fri, 7:30-8:30 pm, concert. Mountain.

KOP, Detroit, Mich. 286 meters. 1,600 ml. Detroit Police Dept. Slogan, "Safety First." Daily ex Sun, 1 pm, 6:30, reports, police information, emergency. Eastern.

KPO, San Francisco, Calif. 423 meters. 1,500 ml. Hale Bros., Inc. Daily ex Sun, 1-2 pm, 4:30-5:30 pm, music. Mon, Tues, Thurs, Sun, 8-10 pm, concert, lectures. Sat, 3-12 pm, music. Sun, 11-12:30 pm, church services. Pacific.

KQI, Berkeley, Calif. 360 meters. Univ. of Calif.

KQP, Hood River, Ore. 360 meters. Apple City Radio Club. Slogan, "Apple City of the West." Mon, Wed, Fri, 6:30 pm, music. Wed, 9 pm, special. Pacific.

KQV, Pittsburgh, Pa. 360 meters. 300 ml. Doubleday-Hill Elec. Co. Daily ex Sun, 12-12:30 pm; 4:30-5, music. Mon, Wed, Fri, 10-10:55 pm, concert. Fri, 4:30-5:15 pm, children's program. Eastern.

KQW, San Jose, Calif. 360 meters. 1000 ml. Chas. D. Herold. Daily ex Sun, 1-1:30 pm, Wed, 8-9 pm, concert. Pacific.

KRE, Berkeley, Calif. 278 meters. 600 ml. Maxwell Elec. Co. Mon, 8-10 pm. Wed, 9-10 pm, concert. Pacific.

KSD, St. Louis, Mo. 546 meters. 1,500 ml. St. Louis Post Dispatch. Daily ex Sun, 8:40 am, 9:40, 10:40, 11:40, 12:40 pm, 1:40, 2:40, 4, 8. Thurs and Sun, silent nights. Central.

KSL, San Francisco, Calif. 360 meters. 50 ml. The Emporium. Temporarily discontinued.

KSB, Long Beach, Calif. 223 meters. Prest & Dean Radio Co. No regular schedule.

KTW, Seattle, Wash. 360 meters. 500 ml. First Presbyterian Church. Sun, 11-12:30 pm, 3-4:30, 7-9:30, church service. Pacific.

KUO, San Francisco, Calif. 360 meters. 1,500 ml. San Francisco Examiner. Slogan, "The Voice of the West." Daily ex Sun, 9-10 am, chat to housewives; 11-12, reports; 2:30-3:30 pm, lecture, news; 9 am, 12 m, 6:45 pm, weather reports. Sun, 9-10 am, 5-6 pm, news. Pacific.

## Serially Continuously—

THE BROADCASTING station directory is the most complete and authentic list of Radiophone plants. Letters are being sent various stations every day for information. No other paper or source provides the data given here. The idea is original and a service which Radio Digest has maintained from the start. Every public service broadcasting station is to be found now, not only in the location index, but in the schedule list. The latter, however is divided, one-fourth appearing this week, the second quarter to appear next week, and the third part the week following and the fourth will have the state, city and station index.

The station schedules given here are listed alphabetically by call letters. Following the call is given the city and state, the wave length, estimated sure miles range of the station, the owner's name, the slogan of the station if one is used, name of listener in "club," the schedule of operating hours, and the kind of time used.

The state, city and call list appears with the last week and is merely an index. One wishing to find the calls of the stations in his vicinity, will find this index useful. Three successive issues of Radio Digest will give one the most complete and accurate list of broadcasting stations obtainable.

KFBC, San Diego, Calif. 278 meters. 500 ml. W. K. Azbill. Thurs, Sun, 8-9 pm, Bible lesson, sermon. Pacific.

KFBE, San Luis Obispo, Calif. 360 meters. 50 ml. R. L. Horn. Mon, Wed, Fri, 4-5 pm. Wed, Fri, 7:30 pm. Pacific.

KFBG, Tacoma, Wash. 360 meters. First Presbyterian Church.

KFBK, Sacramento, Calif. 283 meters. 300 ml. Kimball-Upson Co. Slogan, "Heart of California." Daily ex Sun, 6-6:45 pm, concert, news, codes. Wed, 8-9:30 pm, concert. Sun, 10-11 am, church service; 8-9 pm, concert. Pacific.

KFBL, Everett, Wash. 224 meters. 50 ml. Leese Bros. Daily ex Sun, 7:15-8:15 pm. Sun, 2-3 pm. Pacific.

KFBS, Trinidad, Colo. 360 meters. Chronicle News & Gas & Elec. Supply Co.

KFBW, Laramie, Wyo. 360 meters. Bishop N. S. Thomas.

KFCD, Salem, Ore. 360 meters. 100 ml. F. S. Barton. Tues, Wed, Fri, 7-8 pm. Pacific.

KFCF, Walla Walla, Wash. 360 meters. Frank A. Moore.

KFCJ, Billings, Mont. 360 meters. 500 ml. Electric Service Station, Inc. Wed, Fri, Sun, 7:30-9 pm, music. Mountain.

KFCR, Colorado Springs, Colo. 360 meters. Colorado Springs Radio Co.

KFCL, Los Angeles, Calif. 360 meters. 1,500 ml. Los Angeles Union Stock Yards. Daily ex Sun, 10-10:30 am, 1:15-1:45 pm, 4-4:30, 8-8:20, live stock reports. Thurs, 9-9:20 pm. Pacific.

KFCM, Richmond, Calif. 244 meters. 500 ml. Richmond Radio Shop. Slogan, "Out Where the West Ends." Daily ex Sun, 1-2 pm, music. Tues, Fri, 8-9 pm, music. Pacific.

KFCP, Ogden, Utah. 360 meters. Ralph W. Flygare.

KFCV, Houston, Tex. 360 meters. 1000 ml. Fred Mahaffey, Jr. Daily ex Sun, 7:30-8 pm, markets, entertainment. Sun, 2-3 pm, entertainment. Central.

KFCY, Le Mars, Ia. 360 meters. 300 ml. Western Union College. Fri, 8-9 pm, music, educational. Central.

KFDZ, Omaha, Neb. 360 meters. Omaha Central H. S.

KFDA, Baker, Ore. 360 meters. 25 ml. Adler's Music Store. Daily ex Sun, 5-6 pm, 7-8, music. Sun, 6-8 pm. Pacific.

KFDB, San Francisco, Calif. 509 meters. 1,500 ml. Mercantile Trust Co. Daily ex Sun, 10-11 am, weather, markets; 11-11:30, news, quotations; 2-3 pm, lectures; 7-7:30 pm, reports. Pacific.

KFDC, Spokane, Wash. 285 meters. 25 ml. E. B. Craney. Temporarily discontinued.

KFDD, Boise, Idaho. 252 meters. St. Michael's Cathedral. Sun, 11:15-12:30 pm, 8-9:15 church services. Mountain.

KFDF, Casper, Wyo. 360 meters. 600 ml. Wyoming Radio Corp. Daily ex Sun, 12:30 pm, weather, stocks. Wed, Fri, 8-9 pm, music. Sun, 8-9 pm, sacred music; 11-11:30, music. Mountain.

KFDH, Tucson, Ariz. 360 meters. 200 ml. Univ. of Ariz. Temporarily discontinued. Mountain.

KFDJ, Corvallis, Ore. 360 meters. Oregon Agri. College.

KFDL, Denver, Colo. 360 meters. Knight-Campbell Music Co.

KFFE, Pendleton, Ore. 360 meters. 100 ml. Eastern Ore. Radio Co. Daily ex Sun, 8:30-9:30 pm, music. Pacific.

KFFO, Hillsboro, Ore. 229 meters. Dr. E. H. Smith.

KFFP, Moberly, Mo. 275 meters. 300 ml. First Baptist Church. Slogan, "The Gospel Messenger of the Air." Sun, 10:45 am, 8 pm, church services. Central.

KFFQ, Colorado Springs, Colo. 360 meters. 250 ml. The Marksheffel Motor Co. Daily, 8:15 am, weather; 4-5 pm, concert. Mon, Wed, Fri, 8-9:30 pm, special program. Mountain.

KFFR, Sparks, Nev. 360 meters. 50 ml. Jim Kirk. Wed, Fri, 8-9 pm, "Sagebrush Canaries." Pacific.

KFFV, Lamoni, Iowa. 360 meters. 600 ml. Grace-land College. Wed, 9:20 am, music appreciation. Thurs, 8 pm, entertainment. Central.

KFFX, Omaha, Neb. 278 meters. 600 ml. The McGraw Co. Daily, 2:30-3:50 pm. Central.

KFFY, Alexandria, La. 360 meters. Pincus & Murphy, Inc.

KFFZ, Dallas, Tex. 360 meters. Al. G. Barnes Amusement Co.

KFGC, Baton Rouge, La. 254 meters. Louisiana State University. No regular schedule.

KFGD, Chickasha, Okla. 243 meters. 50 ml. Chickasha Radio & Elec. Co. Slogan, "Queen of the Washita." Daily ex Sun, 11:30-12 am; 9-9:30 pm, music. Central.

KFGH, Stanford Univ., Calif. 360 meters. 500 ml. Leland Stanford Junior University. No regular schedule.

KFGJ, St. Louis, Mo. 266 meters. National Guards Missouri.

KFGL, Arlington, Ore. 234 meters. Arlington Garage.

KFGP, Cheney, Kans. 229 meters. Cheney Radio Co.

KFGQ, Boone, Ia. 226 meters. Crary Hardware Co.

KFGV, Uta, Nebr. 224 meters. 50 ml. Heildreder Radio Supply Co. No regular schedule.

KFX, Orange, Tex. 250 meters. First Presbyterian Church. Sun, 11 am, 7:30 pm, church services. Central.

KFGY, Baudette, Minn. 224 meters. Gjelhaug's Radio Shop.

KFGZ, Berrien Springs, Mich. 268 meters. Emanuel Missionary College.

KFHA, Gunnison, Colo. 360 meters. Colorado State Normal School. "Where the Sun Shines Every Day." Daily ex Sun, 8:30 am, weather, markets. Tues, 7:30 pm, entertainment. Mountain.

KFHB, Hood River, Ore. 280 meters. 50 ml. P. L. Boardwell. Daily ex Mon, 6:20-6:35 pm, sports, news. Sun, 1-1:45 pm, music. Special programs 11 pm. Pacific.

KFHD, St. Joseph, Mo. 226 meters. 50 ml. Utz Electric Co. Daily ex Sun, 5:30-6 pm. Mon, Thurs, Sat, 8-9:30 pm, concert. Central.

KFHF, Shreveport, La. 266 meters. Central Christian Church.

KFHH, Neah Bay, Wash. 283 meters. Ambrose A. McCue.

KFHI, Wichita, Kans. 224 meters. Charles V. Dixon.

KFHJ, Santa Barbara, Calif. 360 meters. Fallon Company.

KFHL, Oskaloosa, Ia. 227 meters. Penn College.

(NOTE—The second part of the station schedule list will appear next week.)

ADVANCE PROGRAMS

(Continued from page 4)

8:30 P. M., Dinner music, Meyer Davis Bellevue Stratford Orchestra; 8:50 P. M., Recital, WGI (Eastern, Daylight Saving, 360). 8:30 P. M., Talk, Richard Thompson. Talk by an eminent psychoanalyst; Concert, Irving Crocker, baritone; Bernard Ryces, pianist. WGY (Eastern, 380), 7:35 P. M., Talk, "Pike and Pickering Fishing." Jud Landon; 7:45 P. M., Program, Salvation Army Band, Samuel Slater, director; "Omnipotency." Band; "Songs That Are Brightest." Arthur Stone, cornetist; "The Ideal Man." Lillian Marsh, reader; "Gems of Heaven." Band; Euphonium solo, "Lodged in the Gradle of the Deep," Albert Tompkins; "La Chute" from "Les Misérables." Mme. Chantemerle, reader; "Andante," Brass quartet; "American Melodies." Band; "Héroisme de l'Obsession passee." Mme. Chantemerle; "Hoffield." Band; Euphonium solo, "By the Sea." John Gallagher; "Maldstone." Band. WHAS (Central, 400), 4:00-5:00 P. M., Concert, Mary Anderson Theater Orchestra; 7:30-9:30 P. M., Concert, Mrs. Jane Webster, Murrell Sunday school lesson, David Sweet, Talk, Mrs. Chas. B. Semple; Reading, "An Interesting Historical Episode." WFI (Eastern, Daylight Saving, 509), 1:00-2:00 P. M., Organ recital, Karl Bonawitz, Germantown Theater; 3:00 P. M., Artist recital; 7:00 P. M., Bedtime stories, Uncle Wip; 8:00 P. M., Short talks; Musical program; 9:00-9:30 P. M., Organ recital, Karl Bonawitz. WJAX (Eastern, 390), 8:00 P. M., Concert, W. Tech Girls' Band and Bamboo Garden Orchestra. WLW (Eastern, 399), 10:00 P. M., Musical program, Elmer Behne's Dance Orchestra; Vocal solo, Mrs. C. Fern Flint; Vocal duet, "When the Great Red Dawn Is Shining." Mrs. C. Fern Flint, Mr. A. J. McClintock; "Concerto," Harry Tomarin, violinist; Old songs with guitar accompaniment, Ed Decker, tenor; Elmer Behne's Dance Orchestra; Vocal solo, A. J. McClintock; "In the Garden of Your Heart," Oh, That My Two Were Mayling, Mrs. C. Fern Flint, A. J. McClintock; Harry Tomarin, violinist; Elmer Behne's Dance Orchestra. WMAQ (Central, Daylight Saving, 448), 4:30 P. M., Program furnished by Lyceum Arts Conservatory; 7:30 P. M., Talk, "Auto Trails," Rockwell Stephens; Talk, "A Scout Citizen," G. L. Schumburg; Radio lesson in synopsation, Axel Christensen; 9:15 P. M., Vocal selections, Giobanni Gennaro, tenor. WMC (Central, 500), 8:30 P. M., Concert, Hotel Chisca Philharmonic Orchestra. WDC (Central, 484), 3:30 P. M., Educational talk, C. E. Wilent; 5:45 P. M., Chimes concert; 6:30 P. M., Sandman. WDD (Eastern, Daylight Saving, 509), 11:00-11:30 A. M., Organ recital, Mary E. Vogt; 12:00-12:55 P. M., Luncheon music, Wanamaker Tea Room Orchestra; 4:45-5:00 P. M., Organ recital, Mary E. Vogt; 7:45 P. M., Dinner music, Hotel Adelphi Roof Garden Orchestra; 8:30 P. M., Recital; 8:45 P. M., Dance music, Hotel Adelphi Roof Garden Orchestra. WWJ (Eastern, 517), 8:00 P. M., Concert, Schmemman's Band; 8:30 P. M., News Orchestra; Town Crier; Julia Wendorff, soprano; Schmemman's Band. body in G Minor," James Early; "Sousedaka," Orchestra. WHAS (Central, 400), 4:00-5:00 P. M., Concert, Mary Anderson Theater Orchestra; 7:30-9:30 P. M., Concert, Shawnee Terrace Dance Orchestra; Reading, "An Interesting Historical Episode." WIP (Eastern, Daylight Saving, 509), 3:00 P. M., Song recital; 8:00-8:45 P. M., Dinner music; 7:00-7:30 P. M., Bedtime stories, Uncle Wip. WMAQ (Central, Daylight Saving, 448), 4:30 P. M., Program arranged by Columbia School of Music; 7:00 P. M., Musical lecture, Mrs. Mark E. Oberndorfer; 9:15 P. M., Vocal selections, Carl Craven, tenor. WDC (Central, 484), 3:30 P. M., Educational talk, C. E. Wilent; 5:45 P. M., Chimes concert; 6:30 P. M., Sandman. WDD (Eastern, Daylight Saving, 509), 11:00-11:30 A. M., Organ recital, Mary E. Vogt; 12:00-12:55 P. M., Luncheon music, Wanamaker Tea Room Orchestra; 4:45-5:00 P. M., Organ recital, Mary E. Vogt; 7:45 P. M., Dinner music, Hotel Adelphi Roof Garden Orchestra; 8:30 P. M., Recital; 8:45 P. M., Dance music, Hotel Adelphi Roof Garden Orchestra. WWJ (Eastern, 517), 8:00 P. M., Concert, Schmemman's Band; 8:30 P. M., News Orchestra; Town Crier; Julia Wendorff, soprano; Schmemman's Band.

Saturday, July 21

CFCFA (Eastern, Daylight Saving, 400), 8:00-9:00 P. M., Musical program, selection from "Carmen," Star Orchestra; Ernest Morgan, baritone; "Traumeri," Jacques Stern, cellist; "Orientale," Orchestra; Ernest Morgan, baritone; "Caprice Viennois," Harry Adaskin; "Dance Trepak," Orchestra; W. Woods, cornetist; Ernest Morgan, baritone; "You're in Love," Orchestra. KDKA (Eastern, 326), 7:20 P. M., Concert, Westinghouse Band, T. J. Vastine, director; Nazareno La Marca, tenor. KGW (Pacific, 492), 3:30-4:00 P. M., Children's stories, Aunt Nell; 10:00-11:00 P. M., Dance music, George Olsen's Orchestra. KHJ (Pacific, 395), 12:30-1:15 P. M., Music; 2:30-3:30 P. M., Matinee musical, Harry J. Beardsley, baritone, reader and author; Edwin Jacobson, violinist; 8:00-10:00 P. M., De Luxe program, Naomi Sweeney Brown, whistler. KSD (Central, 546), 8:00 P. M., Concert, Missouri Theater talent. KYW (Central, Daylight Saving, 345), 8:00-8:58 P. M., Musical program, Jewell Floyd, soprano; Jean St. Anne, baritone; Cope Harvey's Orchestra; Harry Geise; 9:05-9:25 P. M., "Under the Evening Lamp," Youth's Companion. WBAP (Central, 476), 7:00-7:30 P. M., Sunday School Lesson, Mrs. W. F. Barnum. WBZ (Eastern, 337), 7:00 P. M., Concert, Old Fashioned Minstrels; Joe Norcross; Mary L. Waters, accordion; Frank Chase, pianist; 8:20 P. M., Bedtime story for grown-ups, Orison S. Marden. WDT (Eastern, Daylight Saving, 405), 12:00-1:00 P. M., Song revue, Vaughn De Leath. WFAA (Central, 476), 12:30-1:00 P. M., Address, "Current History Comments," Prof. Clyde Egleton, Southern Methodist University; 8:30-9:30 P. M., Mrs. Margie Reagan Cate, reader; Mrs. Cecil Obenchain Reims, violinist; 11:00-12:00 P. M., Recital, Martha M. Whitaker, pianist; Mr. and Mrs. Walter J. Fried, violinists. WGI (Eastern, Daylight Saving, 360), 8:30 P. M., Talk, "New England Business Problems," Arthur R. Curnick; Radio drama, Amrad Players. WHAS (Central, 400), 4:00-5:00 P. M., Concert, Mary Anderson Theater Orchestra; 7:30-9:30 P. M., Musical program, Myrtle George Stinger, soprano; Mrs. Mary Belle Bennett, reader; Mrs. Murray Nicol, soprano; Paul Kelley, tenor; Gaye McBride, baritone; Reading, "An Interesting Historical Episode." Concert, Mary Anderson Theater Orchestra. WMAQ (Central, Daylight Saving, 448), 8:00-9:00 P. M., Concert, Chicago Theater talent. WMC (Central, 500), 8:30 P. M., American Legion program. WDC (Central, 484), 3:30 P. M., Educational talk, C. C. Hall; 5:45 P. M., Chimes concert; 6:30 P. M., Sandman; 9:30-10:30 P. M., Dance program, P. S. C. Orchestra. WWJ (Eastern, 517), 3:00 P. M., Concert, Schmemman's Band; 8:30 P. M., Schmemman's Band.

Friday, July 20

CFCFA (Eastern, Daylight Saving, 400), 8:00-9:00 P. M., Musical program, "May Day," Star Orchestra; Thomas Dunn, baritone; "Canzonetta," Orchestra; "Prelude to the Deluge," Harry Adaskin, violinist; "Gondoliers," Orchestra; Thomas Dunn, baritone; "A Day in Venice," Orchestra; "Mazurka," Harry Adaskin; Thomas Dunn, baritone; "Entrance of the Bojarsen," Orchestra. KDKA (Eastern, 326), 7:20 P. M., Concert, E. Pauline Keys, pianist; Charles Wyllis Hall, tenor; Leo Kruzock, violinist. KGW (Pacific, 492), 8:00-8:45 P. M., Concert, George Dison's Orchestra; Dance music, George Olsen's Orchestra; 10:00-11:00 P. M., Hot Owls. KHJ (Pacific, 395), 12:30-1:15 P. M., Concert; 2:30-3:30 P. M., Concert; 6:45-7:30 P. M., Children's hour, "Uncle John"; 8:00-10:00 P. M., De Luxe program; Address, Dr. Eugene Francis Stokes. KSD (Central, 546), 8:00 P. M., Opera, "The Merry Widow." Open Air Theater, Forest Park. KYW (Central, Daylight Saving, 345), 10:00-11:30 P. M., Musical program, Cope Harvey's Orchestra; Herb Mintz, pianist; Harry Geise. WBAP (Central, 476), 9:30-10:45 P. M., Concert Double Octave of the First Methodist Church. WBZ (Eastern, 337), 7:00 P. M., Concert, Alice Brigham, pianist; WBZ Trio; 8:20 P. M., Bedtime stories for grown-ups, Orison S. Marden. WDAE (Eastern, Daylight Saving, 395), 12:00-12:45 P. M., Organ recital, Stanley Theatre; Dinner music, Arcadia Cafe Concert Orchestra, Feri Sarkozi, director; 2:00-3:00 P. M., Song recital, talk, Betsy Logan; 4:30-5:55 P. M., Dance music; 7:30-8:00 P. M., Bedtime stories, Dream Daddy; 8:00 P. M.-1:00 A. M., Song recital, dance music, Howard Lanin's Arcadia Cafe Dance Orchestra; Songs by Harry Clyn. WDT (Eastern, Daylight Saving, 405), 12:00-1:00 P. M., Talk, "Fast Things to Eat," Vaughn De Leath; Recital, Frank Marone, violinist; "Where the Sacramento River Flows," "Susan," "Drowsy Head," "The World Is Waiting For The Sunrise," Ada Gist, singer; Pearl O'Neil, reader; 11:00-12:00 P. M., Concert, Broadway Musical Alphas. WFAA (Central, 476), 12:30-1:00 P. M., Address, "John, The Apostle," Dr. Robert Stewart Hyer, Southern Methodist University; 8:30-9:30 P. M., Musical program, Joseph Bamsay Brown, tenor; Alex B. Kennedy and assisting singers. WFI (Eastern, Daylight Saving, 395), 1:00 P. M., Dinner music, Meyer Davis Bellevue Stratford Orchestra; 3:00 P. M., Recital, Loretta Kerk, pianist; 6:30 P. M., Dinner music, Meyer Davis Bellevue Stratford Orchestra; 7:00 P. M., Children's Own Half Hour, Cousin Sue. WGI (Eastern, Daylight Saving, 360), 8:30 P. M., Talk, "Silversmith Series," David M. Cheney; Concert, Mary Flaherty, soprano. WGY (Eastern, 380), 7:45 P. M., Music program, "Valse Arabesque," Katharine D. Seaver, pianist; "April Morn," Celia Lamson Herrington, soprano; "On the Road to Mandalay," the Voice of the Sword, Walter J. Thomas, baritone; "If," Ruth Edmonds, reader; "Serenade," Katharine D. Seaver; "Comin' Through the Rye," "Bonnie, Sweet Lassie," Celia Lamson Herrington; "Dreaming Alone in the Twilight," "Boy o' Dreams," Walter Thomas; "Pillow Fight," "Jane, the Disturber," Ruth Edmonds; "Greeting," Celia L. Herrington; "The Mallets Masterpiece," Ruth Edmonds; "Because," Walter Thomas; "Valse Impromptu," Katharine D. Seaver; 10:00 P. M., "Vysokella," The Solka Orchestra; "Spring's Awakening," Ethel Thomas, soprano; "Myahick," Orchestra; "Columbine," James Early, pianist; "Koline, Koline," Orchestra; "Roses, Roses, Everywhere," Ethel Thomas; "Vlastovicka Lita," Orchestra; "Sequidilla," James Early; "Vsecky Mysl za sebo," Orchestra; "Hope On," "Lovely Celia," Ethel Thomas; "Green Groves," Orchestra; "Rhap-

AN EVENING AT HOME WITH THE LISTENER IN (SEE NOTE BELOW FOR INSTRUCTIONS)

Table with columns: Station and City, Mct., Monday, Tuesday, Wednesday, Thursday, Friday, Saturday, Sunday. Lists various radio stations and their broadcast times for each day of the week.

Instructions for Use.—All the hours above are given in Central Standard Time. If your city uses Eastern Time, add one hour to each of the periods stated; if your city uses Mountain Time, subtract one hour; if your city uses Pacific Time, subtract two hours. If in addition your city is using Daylight Saving Time, add one hour to this result.

Monday, July 23

WDAR (Eastern, Daylight Saving, 395), 12:00-12:54 P. M., Organ recital, Stanley Theatre; Dinner music, Arcadia Cafe Concert Orchestra, Feri Sarkozi, director; 2:00-3:00 P. M., Arcadia Cafe Concert Orchestra; Talk, Betsy Logan; 4:30-5:55 P. M., Song recital. WFI (Eastern, Daylight Saving, 395), 1:00 P. M., Dinner music, Meyer Davis Bellevue Stratford Orchestra; 3:00 P. M., Musical program; 3:45 P. M., Song recital; Piano selections; 6:30 P. M., Dinner music, Meyer Davis Bellevue Stratford Orchestra; 7:00 P. M., Children's Own Half Hour, by Cousin Sue. WGY (Eastern, 380), 7:45 P. M., Musical program, "Prelude in G Minor," Edna Schuyler, pianist; "Just a Little Joy Ride," Rosina Holmes, reader; "There's a Lark in My Heart," Mrs. Fred Harris, contralto; Address, "Boshanara Goes Camping," "The Butterfly," Edna Schuyler; "Invocation to Life," Mrs. Fred Harris; "The Sign of the Cross," Rosina Holmes, reader; "Homing," Mrs. Fred Harris; "A Stery Scheme," Rosina Holmes; "Liebestraume," Edna Schuyler. WHAS (Central, 400), 4:00-5:00 P. M., Concert, Mary Anderson Theater Orchestra; Lena Pope, pianist and singer. WIP (Eastern, Daylight Saving, 509), 3:00 P. M., Musical program; 6:45 P. M., Radio Baseball Dope, by Monte Cross, old-time baseball star; 7:00-7:30 P. M., Bedtime stories, Uncle Wip. WLW (Eastern, 399), 8:00-9:00 P. M., Zoo Opera Company; 9:00-9:30 P. M., Roger Hill Dance Orchestra; Talk, "Useful Hints to Campers," Jay P. Garrough, editor of the "Sportsman's Digest," 9:45-10:15 P. M., The Zoo Opera Company. WMC (Central, 500), 8:30 P. M., Concert, Hotel Gayoso Orchestra. WDD (Eastern, Daylight Saving, 509), 11:00-11:30 A. M., Organ recital; Mary E. Vogt; 12:00-12:55 P. M., Luncheon music, Wanamaker Tea Room Orchestra; 4:45-5:00 P. M., Organ recital, Mary E. Vogt; 7:45

P. M., Dinner music, Hotel Adelphi Roof Garden Orchestra; 8:30 P. M., WOO Orchestra; Robert E. Golden, director; 9:30 P. M., Organ recital, Mary E. Vogt.

A Radio set was recently installed in the Assembly in Albany, N. Y., so that members can listen in on concerts and other entertainments during their dull periods.

DONT PASS THIS-BUY World Radio Batteries SAVE YOU 50% WRITTEN 2YR GUAR

SPECIAL 2-Volt Storage Battery for WD-11 and WD-12 Tubes. Will give \$5 200 HOURS on single charge... World-Radio-Batteries Are unconditionally guaranteed Because you deal direct with a manufacturer who is responsible for the performance and quality of the Battery.

Northern Electric Peanut Tubes, Type 215A DEALERS—ATTRACTIVE DISCOUNTS NOTE: We are the Largest Exclusive Radio Jobbers in the Middle West HUDSON-ROSS 123 W. Madison St. Chicago

Freshman Fix - 0 A Fixed Resistance Leak Combination—4 in ONE Price Complete 65c Freshman Condenser Leak Mounting Freshman Fixed Leak SAFE-T HANDLE Furnished in any value of Resistance from 1/2 to 10 Megohms. Separate Condenser and Mountings, 40c. Separate Leaks with Safe-T Handle, 30c. At your dealers, otherwise send purchase price and you will be supplied postpaid. Chas. Freshman Co. Inc. Radio Condenser Products 106 SEVENTH AVE., NEW YORK

Book Of 47 Hook-Ups by an Expert Radio Engineer Forty-seven different ways of making your own set. Each hook-up designed by an expert radio engineer and was tested for accuracy. Every one of these hook-ups will give splendid results. Each hook-up contains detailed information on construction and operation. Thousands of these books are now in use by amateurs and professionals all over the United States. You will get more practical radio information and instruction from this book than from almost any other source. Send your order today. Enclose one dollar with order. ELS RADIO CO. 610 Randolph Bldg., Chicago, Illinois

RUSONITE CRYSTAL RECTIFIER (Patent Pending) THE PERFECT SYNTHETIC CRYSTAL DETECTOR, SENSITIVE OVER ENTIRE SURFACE. No Hunting for "Spots." Loud and Clear. Endorsed by thousands of satisfied users. Sensitivity Guaranteed. 50c 14 K. GOLD SUPERSENSITIVE RUSONITE CATWHISKER. Permanent. Will Not Oxidize. Price... 25c RUSONITE REFLEX CRYSTAL. Manufactured Expressly for Reflex Circuits. Will Stand Up Under Heavy Plate Voltage. Guaranteed. Price, Mounted... \$1.00 Order from your dealer or direct from RUSONITE PRODUCTS 15 Park Row New York, N. Y.

# Radio Digest

## Illustrated

REG. U. S. PAT. OFF. AND DOM. OF CANADA

Published by the Radio Digest Publishing Company, Inc.  
123 West Madison Street  
Telephone State 4844-4845  
Chicago, Illinois

E. C. RAYNER, Publisher  
Chas. F. Smisor, Editor Evans E. Plummer, Managing Editor  
Harry J. Marx, Technical Editor

Eastern Representative, Jacob Miller, Times Bldg., Times Square,  
New York; Telephone Bryant 4909

Pacific Coast Representatives  
E. J. Wood, 251 Kearney St., San Francisco  
Telephone Kearney 1472

H. M. Morris, 417 Western Mutual Life Building, Los Angeles  
Telephone 12011



PUBLISHED WEEKLY

SUBSCRIPTION RATES  
Yearly.....\$5.00 | Foreign.....\$6.00  
Single Copies, 10 Cents

Vol. VI Chicago, Saturday, July 21, 1923 No. 2

## Growing Usefulness

Private Communication and Testing Disease

IN THE press dispatches we read that the governor of the state of New York addressed the people of the entire commonwealth by Radio. He sat in the governor's chair in the executive suite where Radio experts had prepared the proper transmitting devices. Out in California the president of a transporting company Radioed his address at the annual meeting so that the various communities in the central portion of the state, served by the company, could hear him speak. The announcement comes that an invention has been perfected to solve the problem of maintaining privacy in Radio communication. Dr. Albert Abrams of San Francisco announces the invention of a super Radio set to test disease. And so it goes.

Radio today is annihilating distance. Its greatest usefulness will be felt when through unified organization the service of experts can be broadcast to the people of the country on a definite schedule.

## Interest Increases in Learning Code

When Signals Are Mastered the Enjoyment Is Broadened

USUALLY the beginner, upon hearing some code signals, will throw up his hands and proceed to condemn such stations for interference with his broadcasting program. If, on the other hand, such a man would take the trouble to learn this same code, he would find his fun increased 100 per cent.

The code is not such a difficult thing to learn, if the beginner will but sit down and practice it every night for an hour or so. It is just like learning the piano; it is mostly practice. Do not think by listening to it once in a while for a brief spell that you will soon be in a position to receive everything that goes through the air, because you will surely be disappointed. Practice, with a capital P, is what is needed.

Before any receiving is to be attempted, first get a buzzer, a battery and a key, and practice sending until you have learned all the characters. Be sure to include the numerals in this practice, and although they are not hard to remember, they sometimes prove confusing when receiving a higher rate of speed.

## Demand Is for Quality

Critics Insist That Stations Produce Best Talent

WHEN Radio broadcasting first became popular the person listening in was thrilled upon recognizing sounds as music or as someone was speaking. This listener in was generally, at that time, an amateur Radio telegraph operator, as no one yet had purchased apparatus to listen to the experiments being conducted by one of two prominent Radio experts. In fact the Radio amateur may be said to be the one who sold Radio broadcasting to the public, for the average person usually wants to have a demonstration before he invests money in a new idea.

Since that day many changes have taken place. The public has become a large body of critics and the big station of today, to court favor, must produce the goods. The Radio listener of today, generally a man, woman or child without any knowledge of the Radio code, and probably not much interest in it at that, sits back and carefully compares the quality of the different stations within reach of his apparatus. The average person has now become quite well acquainted with needed apparatus and how to operate it to get best results.

It is needless to say that the period of wonderment has passed and the one who listens in realizes that the quality of music and talent from the original broadcasting station could be very much improved.

Radio will be a part of every household for the same reason that the phonograph became successful. People want music and instead of going to the music, it is now brought to them. From the present viewpoint, there is yet no limit to what Radio may be called upon to do, but it is not necessary to here repeat the many and varied activities to which Radio can be applied.

## RADIO INDI-GEST

### INDI-GEST BORED TO TEARS WHEN SONGSTRESS PUTS HERSELF ON AIR



WALLA WALLA. — Indi-Gest, famous builder of the nameless broadcaster on this notorious isle, was overcome with emotion yesterday evening as the sun was rising when the postman delivered the noon mail. The cause, as many had very improperly hypothesized, was not due to drawing his boots over a bunion, but was found to be the receipt of a hand painted snapshot of his friend Yuma Yama, prima donna of awful repute.

"Many's the time we have eaten missionaries together," said Mr. Gest when interviewed almost exclusively for this column. "And now to think," continued he gravely, "Yuma has volunteered her services free, gratis, and without charge, that her slightly cracked voice may be graven on the Walla Walla microphone. Why, her singing will bring the house down." As a precautionary measure, however, the cables will be doubled by Mike and Izzy, the antenna raisers, so that Yuma's voice will not bring down the antenna as well.

### Caught as Catch Could

Said a Radiophan,  
As he tuned in his set:  
"This is catch-as-catch-can,  
I must take what I get."  
Then he turned on a wheel  
And the stuff that he got—  
A political spiel—  
Made him swear quite a lot.

WALT DRUMMOND

### So Is this Joke

Dear Sir: Suthin's gottabe did. Yessir, things is almost miserable relative to the purchasing of Radio parts. The dealers don't even keep 'em fresh. Nosiree! Why just thuther day we read where one of those bimboes wuz selling variocouplers, variometers and condensers that wuz moulded.

SPIDER WEBB.

### Or Perhaps Sermons

First Farmer: "How does yer hired man like your new Radio, Josh?"

Second farmer: "Fine. Only he mistakes everything he hears for bedtime stories."—*American Legion Weekly.*

### A-B-C Lessons for Indigest Beginners

Chapter V—How to Acquire a Large Vocabulary  
BY GOSH

IS for errors  
We make in hooking up,  
Put forty volts across the tube  
And hear our cash go—plup!

### This Adv. Cost 40c an Agate Line

Dear Indi: The other day I was digesting a grid leak when I stops the feedback stunt long enough to remark to a friend, about said leak having no juice. Then he springs the old one about "Why do you do it, charge it with Tungar." Yours to a cinder, MIKE ROFARADS.

### Wot the Hoot?

Dear Mr. Gest: May I call your attention to the announcement in the advance program for Station WWJ, Detroit News, that following the Town Crier, Mr. C. L. Hoot, bass, would sing?

POLLY W.

Here rests Tommie  
DeLacey McKinner.  
A bolt of lightning  
Struck his antinner.

### HELP! HELP!

I have a little tube set  
Which likes me not, I fear;  
I turn one of its dials  
And it shrieks into my ear.  
It whistles, moans and gurgles—  
Though I've sat with it all night  
It howls and screeches eerily,  
Which seems most impolite.  
I'm sure I should be satisfied  
Would it obey my hand  
And say just one small thing to me  
That I could understand!

LE MOQUER

### INDI-GEST KINKS? SEND A DOLLAR—

THERE are many little Indi-Gest kinks worked out in the home that would hamper your fellow Radioknut and cause him much worry. Indi-Gest is very much interested in securing such material and is willing to accept a dollar for each kink printed. Send a stamped envelope so rejected copy may be returned. Under no circumstances will the dollar be sent back.

INDI-GEST KINKS DEPARTMENT

E. Sa. P. hastens to submit a kink for the well-known Indi-Gest Kinks Department for the benefit of fellow Knuts troubled with too much interference. He claims that this trouble may be definitely and assuredly stopped by the simple procedure of removing from their sockets one's vacuum tubes. He adds that this also is sure of eliminating all tube noises. Odds are 3 to 1 that E. Sa. P. is a surgeon specializing in appendicitis.

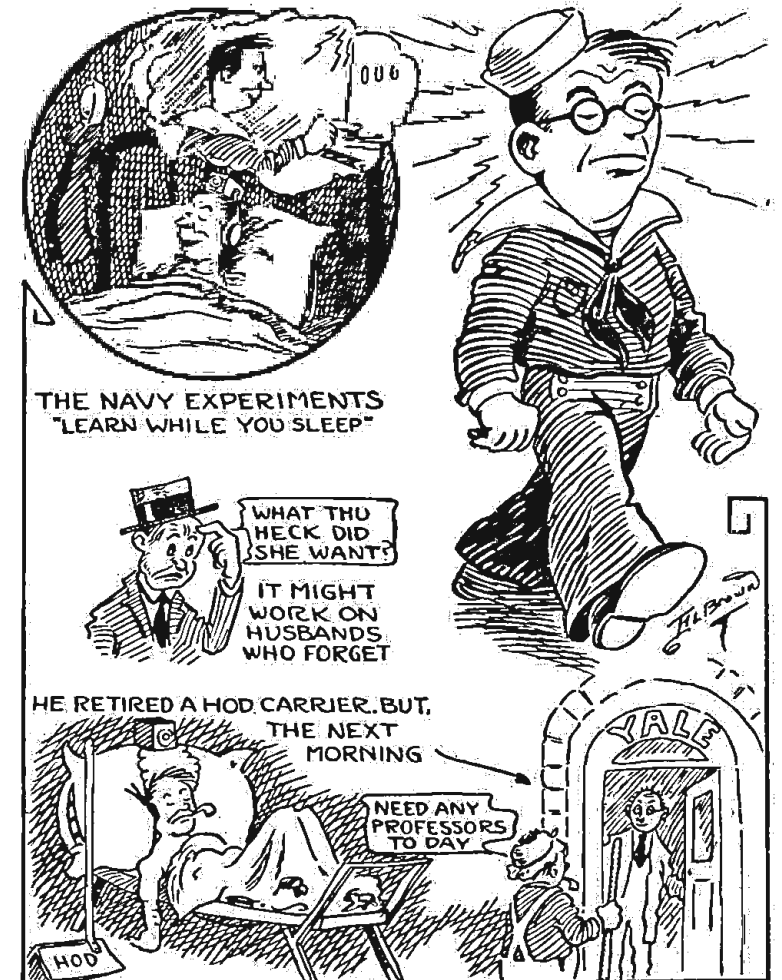

THE NAVY EXPERIMENTS  
"LEARN WHILE YOU SLEEP"

WHAT THU  
HECK DID  
SHE WANT?  
IT MIGHT  
WORK ON  
HUSBANDS  
WHO FORGET

HE RETIRED A HOD CARRIER, BUT,  
THE NEXT  
MORNING

NEED ANY  
PROFESSORS  
TO DAY

## Condensed

By DIELECTRIC

It is quite an easy matter, and more or less popular, to lay to modern discoveries the seeming tendency away from clear thinking and concentrated study producing a "scatter-brained race" (in the words of James M. Beck). Long before the day of broadcasting lectures, presidential speeches and Will Rogers' paraphrases, we had many evidences of the condition he claims is concurrent with Radio, movies, etc. The fact is that Radio broadcasting has provoked thinking, rather than the reverse, and has brought knowledge to men who otherwise would never have acquired it.

The day of Radioed movies is close at hand, if we may believe the assertion of Mr. Jenkins, whose ability to transmit still pictures via Radio is well known. At a test in his laboratory he showed upon a screen in an adjoining room movements of various objects held in front of the apparatus. Someone will produce and provide for the use of broadcasting stations, movies for home enjoyment. The motto "there is no place like home" is coming true.

Radio is rapidly extending its usefulness into the field of law enforcement. The police department of Los Angeles has been testing Radio equipment as a means of quickly cornering criminals. With officers' cars equipped with receiving sets, details of a crime and the direction followed by the criminal may be broadcast all over a city or section of country and result in lessening the chance of escape. Where practical objects are to be served Radiophony is just as much valued as by those who seek its entertainment.

Prizes are still being offered to listeners in which add to the zest of getting and holding distant stations. One such DX listener was aboard the steamship Belgian when Station WNAÇ was broadcasting a concert by the Copley-Plaza orchestra. Songs of ancient vintage were broadcast and to the one correctly naming the largest number of them a five-pound box of candy was awarded. It is sweet indeed to hear some of the old songs; sweeter yet in this case.

The comparatively new station, WJAZ, in Chicago, was used by the Commandant of the Illinois Naval Reserve to broadcast a number of talks to his fellow citizens, hoping to gain recruits thereby. From reports gathered since, it is quite evident that many who heard him on these occasions were induced to enlist in the service. It might seem useless to urge such action upon a man when he is comfortably seated at his set, but there are the facts. Radio did it!

Instances have been cited intending to prove the nuisance of receiving sets with loud speakers when placed near an open window or projected from a store. Talking machines have played an important part in disturbing the general tranquillity of a neighborhood in exactly the same manner. It is undeniable that either of these may cause neighbors to complain when foisted upon them uninvited. It is best to keep the loud speaker indoors in crowded sections and thereby avoid providing fuel for anti-Radio fanatics.

Comparable to the recent situation developed here because of the action of certain music publishers, the British Broadcasting Company is intending to meet the banning of broadcasting of plays by the Theatrical Managers' Association of London by building a studio-theater at Savoy Hill and organizing their own theatrical companies. This is a sensible way to overcome such difficulties, especially in view of the different technique required for producing realism when broadcasting plays from a studio.

# First Steps for Beginners in Radio

## Chapter X—Audio Frequency Amplifiers

By Thomas W. Benson, A. M. I. R. E.

**BEGINNERS** will find the accompanying series by Mr. Benson very helpful in learning the rudiments of the popular science of Radiotelephony. The articles yet to appear are:

- Chapter XI—How Super Regeneration Is Accomplished.
- Chapter XII—Reflex Circuit Operation.
- Chapter XIII—About Headsets and Loud Speakers.
- Chapter XIV—Batteries Used in Radiophony.

**A**UDIO frequency amplifiers serve to increase the volume of sound obtained from the receivers or loud talker connected to the Radio set. Where the Radio frequency amplifiers act to increase the range of a set by taking the very weak impulses and amplifying them till they will operate the detector ef-

lar to its action as a Radio frequency amplifier. Its operation may best be understood when considering its action when amplifying the signals from a crystal detector as shown in Figure 43. Here we have a standard crystal detector circuit with the exception that an audio frequency transformer has its primary winding connected in place of the telephone receivers. The secondary of the transformer is connected to the grid and filament of a hard tube having 45 to 90 volts on the plate.

A potentiometer is shown to control the potential of the grid. The grid potential is adjusted to such a value that the plate current is halfway down the curve as mentioned in connection with the Radio frequency amplifiers.

When signals are being received the current that would normally flow in the telephone receivers now flows in the primary of the transformer. These currents induce a current in the secondary of the transformer that acts to vary the grid potential. In this manner the current flowing through the telephone receivers is

age applied to the grid of the tube so as to pass the saturation point, signals would be distorted, for part of the wave on the grid would be clipped off because the plate current could not respond.

tion is shown in Figure 44. It will be noted that two potentiometers are used. One acts to vary the voltage on the plate of the detector to obtain the best point of operation. The second is for the purpose

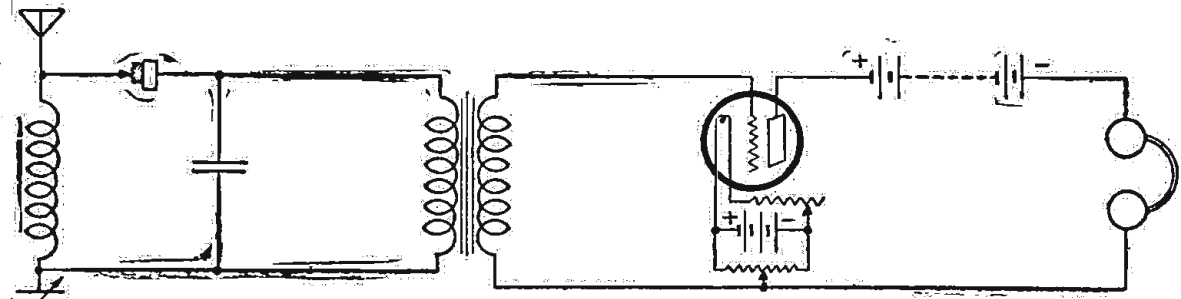

Figure 43—How an amplifier tube is used to increase the strength of signals from crystal detector

ciently, audio frequency amplification takes the audible signals and amplifies them till they can be heard for quite a distance or all over a large room. In deciding how to use a certain number of tubes it is well to keep the above in mind. Thus if one desires maximum range and is willing to sacrifice signal strength one or two stages of Radio frequency amplification should be employed and fewer audio stages. Where volume of sound is desired regardless of range then two stages of audio amplification should be used.

varied to reproduce the music or speech in much greater volume.

### Step Up Ratio Transformer

The higher the voltage used on the plate the louder will be the resulting signals, and, as we have learned previously, the greater the change in grid potential the louder the signals received. To this end, use is made of transformer with a step up ratio. Thus we see transformers advertised with ratios of 2 to 1 or 5 to 1, which means that the voltage of the secondary is twice or five times as great as that applied to the primary. This step up in voltage increases the variations in grid voltage but we must be careful not to overdo this increasing of voltage.

The curve shown in connection with tube detectors flattens out at both ends. That

**Tubes Connected in Cascade**  
The problem of connecting tubes in cascade for audio amplifiers is somewhat simpler than in the case of Radio amplifiers. When the Radio currents have been converted to audio currents the frequency

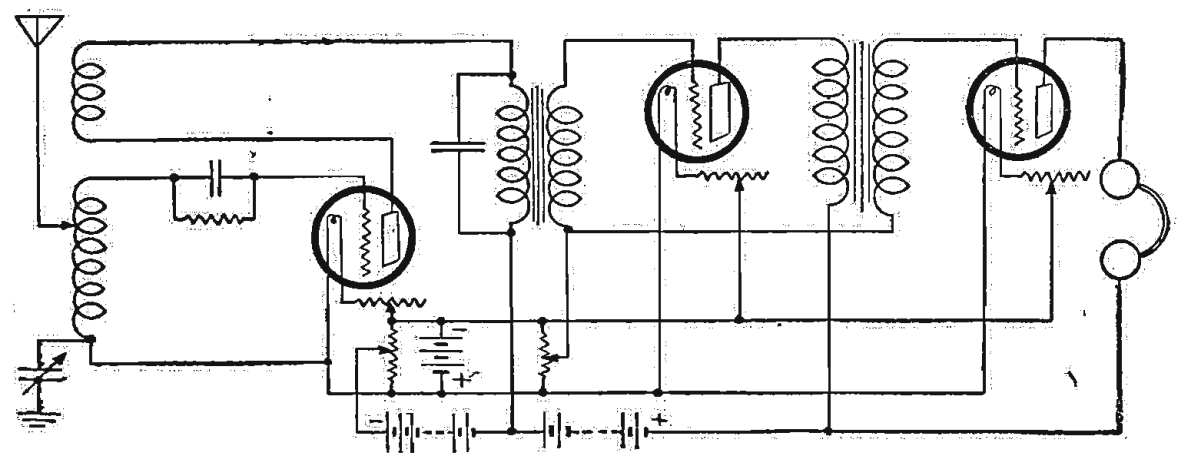

Figure 44—A fully developed circuit for two stage audio frequency amplifier

has been reduced and capacity losses in the tube and circuits are greatly reduced. On the other hand we have currents that vary greatly in frequency and the transformers used must work efficiently over a comparatively wide band of frequencies.

To accomplish this the transformers are designed with what is termed a flat wave characteristic which simply means that the transformer has no sharp point of resonance or is not tuned to a particular frequency. The transformer will then handle currents varying widely in frequency with maximum efficiency.

is, after a certain voltage is applied to the grid an increase of voltage will no longer cause a change in plate current and the tube is said to be at its saturation point. Now were we to use a high ratio transformer that would increase the volt-

## Long Distance Crystal Set

We receive programs from Atlanta, Minneapolis, Davenport, Fort Worth, Dallas, Kansas City, St. Louis, Denver on Crystal without batteries. Usual crystal set requires only easy, inexpensive changes. Send stamp for further information or \$1 for copyright drawings and instructions. Everything clearly explained. Satisfaction GUARANTEED.  
Leon Lambert, 501 South Volusia, Wichita, Kan.

**Delicate Soldering**

Both the manufacturers' and amateurs' problems on all fine work are readily solved by the instrument constructed for this particular purpose.

**THE POST SOLDERING IRON**

Platinum Heating Unit—Interchangeable Tips—Universal Current

(Large and Small)

**\$6** ONE-HALF ACTUAL SIZE

Awarded Certificate of Excellency, N. Y. Evening Mail Radio Institute

From your Dealer, or write

**POST ELECTRIC COMPANY** (Dept. 509), 30 E. 42nd St., New York

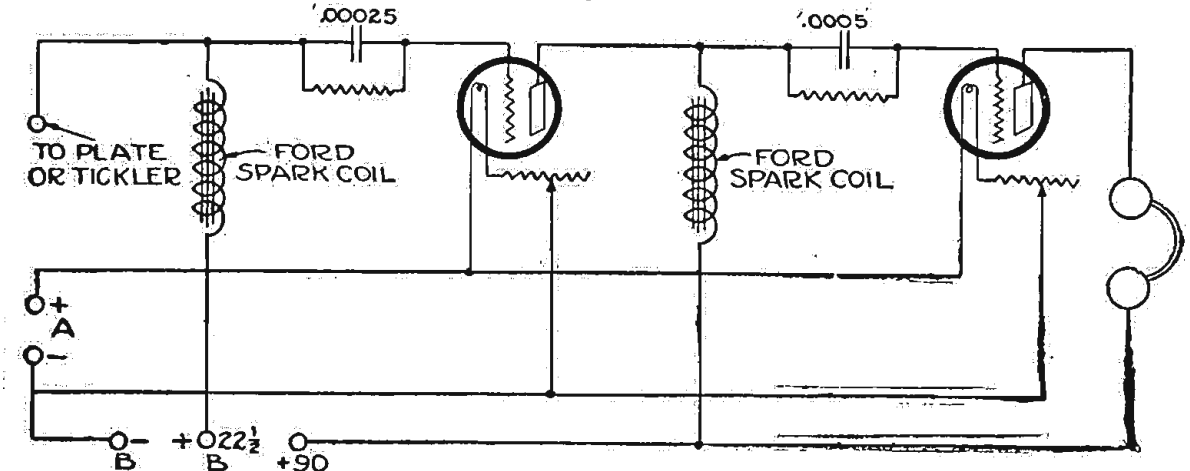

Figure 45—Circuit for a two stage impedance coupled amplifier using Ford spark coils

### Transformers and Filament Control

For that reason the transformer ratios may be larger in the first stages and smaller in the second stage. This is due to the voltage in the first stage being low but after being amplified by the first tube the voltage is increased and a high ratio transformer may push it too high. Increasing the voltage on the plate increases the length of the plate current curve and when distortion results from too high a ratio in the transformers it may be eliminated by increasing the plate voltage.

of controlling the grid potential of the amplifying tubes. Many persons operate amplifying tubes without a potentiometer but maximum results are seldom obtained without some means of bringing the tubes to the point of best response.

The circuit shown employs no jacks and it is the writer's opinion that it is preferable to eliminate the jacks. They are often a source of noise that is difficult to locate, needlessly complicate the circuit,

(Continued on page 14)

Increasing the filament brilliancy has the same effect but should only be done with caution for pushing the filament shortens its life and may make the proceeding rather expensive.

### Regenerative Circuit

A fully developed circuit using a regenerative tuner with tickler feedback and two stages of audio frequency amplifica-

**NEW CARTER JACK SWITCH**

For closing battery circuits, etc.

Mounts like a Jack See Your Dealer

Price \$1.00—Write for free Jack Switch hook-ups.

Also other spring combinations.

**CARTER RADIO CO.** 205 S. State St., Chicago

**THE LARGEST RADIO STORE IN AMERICA**

## BUILD YOUR OWN SET

**THE LARGEST RADIO STORE IN AMERICA**

ACCORDING TO OUR INSTRUCTIONS  
RESULTS GUARANTEED—PANELS ON ALL SETS DRILLED—READY TO MOUNT

<p>Complete Parts for Knocked-Down Receiving Set \$17.95</p> <p>CONSISTING OF</p> <p>2 Variometers ..... \$10.00 \$3.90</p> <p>1 Variocoupler ..... 5.00 1.75</p> <p>3 Bakelite Dials ..... 3.00 .75</p> <p>Remler Bakelite Socket. 1.00 .45</p> <p>Howard Rheostat .... 1.10 .80</p> <p>Cunningham C-300 Detector Tube .... 5.00 4.45</p> <p>Mahogany Cabinet ..... 4.50 2.75</p> <p>Genuine Formica Panel 2.25 1.75</p> <p>8 Binding Posts ..... .80 .40</p> <p>Switch Lever ..... .50 .25</p> <p>12 Switch Points ..... .40 .20</p> <p>Freshman Grid Leak and Condenser Combined.. 1.00 .75</p> <p>Complete Drawing for Assembly and Wiring ..... 1.00 .50</p> <p>Regular Price ..... \$30.85</p> <p>Our Price \$17.95</p>	<p>Complete Parts for Reinartz Sets \$11.45</p> <p>CONSISTING OF</p> <p>7x18 Formica Panel... \$1.89 \$1.70</p> <p>Remler Bakelite Socket. 1.00 .45</p> <p>Howard Vernier Rheostat ..... 1.50 1.35</p> <p>23 Plate Variable Condenser ..... 3.30 1.45</p> <p>11 Plate Cuni Variable. 3.10 1.35</p> <p>3 Switch Levers ..... 1.50 .75</p> <p>2 Dozen Switch Points. .80 .40</p> <p>1 Schoonhoven Reinartz Coil ..... 3.00 1.95</p> <p>Freshman Variable Grid Leak and Condenser Combined ..... 1.00 .75</p> <p>8 Binding Posts ..... .80 .40</p> <p>25 Feet Tinned Wire. .30 .20</p> <p>Baseboard for Mounting .50 .25</p> <p>Blueprint with Complete Instructions for Assembly and Wiring 1.00 .50</p> <p>Regular Price ..... \$21.69</p> <p>Our Price \$11.45</p>	<p>Complete Parts for 2 Step Amplifier \$12.45</p> <p>Can be used to amplify Reinartz, Flewelling, Short Wave Receiver, Crystal, Ultra Audion or any Receiving Set so that Loud Speaker or Phonograph can be used in place of Head Set.</p> <p>CONSISTING OF</p> <p>7x10 Formica Panel or Other Suitable Size. \$1.05 \$0.85</p> <p>High Ratio All-American or Thordarson Transformer ..... 4.75 3.95</p> <p>Low Ratio Thordarson or All-American Transformer ..... 4.50 2.95</p> <p>2 Howard Rheostats ..... 2.20 2.00</p> <p>2 Remler Bakelite Sockets ..... 2.00 .90</p> <p>3 Double Facet Jacks. 3.00 1.50</p> <p>13 Binding Posts ..... 1.30 .65</p> <p>Baseboard for Mounting .30 .15</p> <p>Regular Price ..... \$20.10</p> <p>Wiring Diagram, with Complete Instruction for Drilling and Assembling Panel \$12.45</p>
<p>Complete Parts for Flewelling Circuit \$12.45</p> <p>CONSISTING OF</p> <p>6x14 Formica Panel... \$1.26 \$1.10</p> <p>23 Plate Variable Condenser ..... 3.30 1.45</p> <p>Three .006 Mica Condensers ..... 3.00 2.25</p> <p>CRL Variable Grid Leak ..... 1.85 1.35</p> <p>Remler Grid Leak ..... .40 .25</p> <p>2 Coil Adjustable Honeycomb Coil Mounting with Knobs ..... 4.00 2.65</p> <p>50 Turn Honeycomb Coil .75 .40</p> <p>75 Turn Honeycomb Coil .80 .40</p> <p>2 Remler Coil Mounts with Straps ..... 1.20 .80</p> <p>1 Remler Bakelite Socket ..... 1.00 .45</p> <p>Howard Vernier Rheostat ..... 1.50 1.35</p> <p>1 Bakelite 3" Dial ..... 1.00 .25</p> <p>8 Binding Posts ..... .80 .40</p> <p>1 Baseboard for Mounting ..... .30 .20</p> <p>1 Blueprint with Complete Instructions for Assembly and Wiring. 1.00 .50</p> <p>Regular Price ..... \$22.16</p> <p>Our Price \$12.45</p>	<p>Complete Parts for Ultra Audion Circuit, \$11.90 (Known as the Wonder Circuit)</p> <p>CONSISTING OF</p> <p>9x10 1/2 Formica Panel. \$1.42 \$1.20</p> <p>23 Plate Condenser ..... 3.30 1.45</p> <p>Bakelite Socket ..... 1.00 .45</p> <p>Special Ultra Audion Coil, plain or bank wound with tape ..... 3.00 1.95</p> <p>Howard Vernier Rheostat ..... 1.50 1.35</p> <p>CRL Grid Leak ..... 1.50 .95</p> <p>.0005 Micon Condenser. .35 .25</p> <p>2 Switch Levers ..... .70 .50</p> <p>18 Switch Points ..... .50 .30</p> <p>2 Switch Stops ..... .10 .05</p> <p>8 Binding Posts ..... .80 .40</p> <p>Genuine Solid Mahogany Cabinet, size 9x10 1/2, with hinged top. 5.00 2.95</p> <p>25 ft. Hookup Wire. .20 .10</p> <p>Regular Price ..... \$19.37</p> <p>Each order includes complete instructions for drilling, assembling and wiring. These construction plans are not drawn in schematic form but are drawn so that any one without any technical knowledge can follow with ease.</p> <p>Our Price ..... \$11.90</p>	<p>Complete Parts for Single Tube Reflex Circuit \$32.65</p> <p>CONSISTING OF</p> <p>43 Plate Vernier Variable Condenser ..... \$7.00 \$3.95</p> <p>Radion Loop Aerial ..... 8.50 5.95</p> <p>Cunningham C301-A Tube ..... 9.00 5.95</p> <p>Grewol Glass Inclosed Detector ..... 2.00 1.65</p> <p>Erla Radio Frequency Transformer ..... 4.50 3.45</p> <p>All-American 5 to 1 Radio Audio Frequency Transformer. 4.75 3.95</p> <p>2-.001 Micon Condensers .70 .50</p> <p>1-.002 Micon Condensers .45 .35</p> <p>Howard Potentiometer. 1.50 1.35</p> <p>Howard 25 Ohm Rheostat ..... 1.10 1.00</p> <p>8 Binding Posts ..... .80 .40</p> <p>9x10 1/2 Formica Panel. 1.42 1.20</p> <p>9x10 1/2 Genuine Solid Mahogany Cabinet with Hinged Top. 5.00 2.95</p> <p>Complete instructions for drilling, assembling and wiring furnished so that any one with no technical knowledge can easily follow. Regular price, \$32.65</p> <p>\$15.22. Our Price. \$32.65</p>

We guarantee all merchandise purchased of us. Mail orders receive immediate attention.

BUY HERE FOR LESS

**CHICAGO SALVAGE STOCK STORE**

509 South State Street Dept. R. D. CHICAGO, ILLINOIS

# How to Make a Storage B Battery

## Use Old A Battery Parts in Construction

The following B storage battery was entirely made out of the parts of an old storage or automobile lighting and starting batter. There are enough parts

### WORKSHOP KINKS? EARN A DOLLAR—

**T**HERE are many little kinks worked out at home that would aid your fellow Radio worker if he only knew about them. There are new hook-ups, new ways of making parts and various unique ways of operating sets that are discovered every day. Radio Digest is very much interested in securing such material. Send them in with full details, including stamped envelope so rejected copy may be returned. The work must be entirely original, not copied.

RADIO KINKS DEPARTMENT,  
Radio Digest  
123 West Madison St., Chicago, Ill.

in one 6-volt battery to make three very neat and serviceable 20-volt storage B batteries.

Each jar of the B battery is made from a jar of the A battery. The jar is cut off 3 1/2 inches from the bottom. The rubber should be warm when working it. If possible leave it in the sun for two or more hours and then it may be cut by drawing a sharp knife across the surface point downward. This will not cut the rubber through but it may be turned over and the cut repeated on the other side and then the rubber will break where the cut was made by bending it back. When cutting the jar off it is best not to have it too warm, and to use a hack saw instead of a knife. If the rubber is cut while cold there is great danger of breaking it and damaging the whole jar.

Out of the remaining upper half of the jar cut nine strips as wide as the inside of the jar and as high as the inside height of the jar. These are for the partitions to separate the cells of the battery and should fit as snug as possible when they are in place as shown.

#### Making Partitions

Heat some battery compound until it becomes liquid. Stand a partition in place and pour the heated battery compound in the first cell. Turn the jar sideways so as to let the compound run in and seal the strip to both walls and the bottom. Use as little compound as possible. This may be done best by having the compound very hot and pouring plenty in the cell then pouring out the surplus. If just a little has been poured in it cools too quickly and cannot be made to fill the crevices. Let this cell stand for a minute and then proceed with the next cell in the same manner.

After the cells have all been sealed they should be tested by pouring water into every other one and let them stand for a while. If one of the strips is not properly sealed it will show up in the adjoining cell, filling it with water.

Ten positive and ten negative plates are cut out of the positive and negative lead plates, respectively, from the old A battery. The plates should be cut about 1/2 inch narrower than the inside of the jar and about 3/4 inch shorter. The plates may be cut with a hack saw, or, by cutting a groove in both sides of the plate with a knife and breaking it on the cut. The separators should be about 1/4 inch larger than the plates. The former

## CUTTING THE CELL AND PLATES

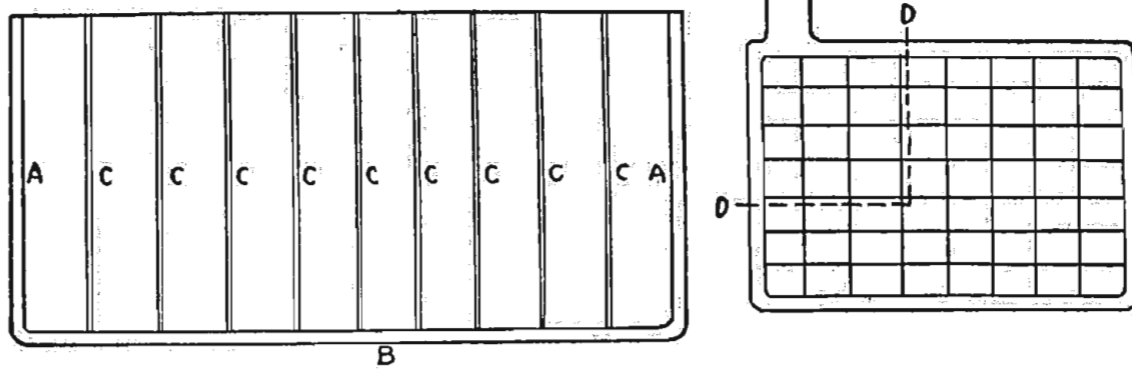

are cut from the old separators in the A battery.

#### Assembly and Charging

One positive and one negative plate and a separator is used to make up the elements of one cell, the negative of one cell being soldered to the positive of the next cell.

If you are not sure that the old battery torn down for making this battery was in a charged condition (which they seldom are), it is a good plan to fill the old battery with distilled water and then charge it for a few hours. This will bring the old acid out of the plates and into the distilled water. Then it is poured off.

After the battery has been charged with the distilled water in it and the water taken out, fill the battery with a sulphuric acid solution until it tests to 1250 on the hydrometer, and charge it at a 1/2 ampere charging rate. When the battery has been fully charged it will gas or bubble, a condition that will be readily recognized. Then it is ready for service. This initial charge may take some time, depending on the condition of the plates. The battery should be placed on charge as soon as possible after the acid has been placed in it. When fully charged the battery should give about 22 1/2 volts, but as the charge runs down it will drop to about 20 volts.

#### Care and Treatment

Such a battery should stand up for several weeks when used only on a single tube. If used on more tubes the life, of course, will be accordingly shorter. One of these batteries made up like this has been used on a five tube set in series with a manufactured B storage battery and it has compared splendidly.

When the voltage drops to about 20 it is time to recharge it. This can be done much quicker than the original charge. When fully charged the acid specific gravity should test to about 1250. If, however, the battery was not previously charged with distilled water as directed, the gravity may run higher than this figure on account of the acid that was in the plates before the new acid was poured in, thus raising the amount of acid in the battery.

The specific gravity method of testing is not to be relied upon entirely in such small batteries, as the amount of acid required to neutralize the plates may be so small as not to affect the solution.

**Ritter Loop Aerial \$1**  
Including wood parts—wire and binding posts. Can be assembled in a few minutes—Portable, requires little space, 36 inches across. Interference—Static—Lightning practically eliminated. Instructions with every SET. By Mail, 10c Extra.  
Ritter Radio Company  
230 Canal Street, NEW YORK

This holds true more especially where small plates are used in a comparatively large container or jar.

When charging the battery the best way is to charge it each time until it gases. When a battery gases it is a sure indication that there is no acid left in the positive plates and the battery is therefore fully charged.

The battery should never be shorted to tests its condition, and it should never be left standing long discharged.—E. A. Johnstone, Pocatello, Idaho.

#### Protection for Filaments

The Radiophan is apt to experience disappointment when he finds that the high voltage leads from the B battery have been accidentally connected across the filament posts of his receiver and one or more tubes are burned out. Although the normal life of the average filament is considerably more than 1,000 hours, it requires but an instant to destroy this delicate filament when excessive voltages are applied to its terminals.

When filaments are shorted across a 20, 40 or 60-volt battery in new condition, the burnout requires but a fraction of a second, and unless the user happens to be inspecting the tube at the instant of the flash, the damage would not be discovered until the set was used again. It is a very easy matter to protect tube filaments by either of the following means:

Insert a 100-ohm (noninductive) resistance for each 22-volt block or B battery in the circuit next to the positive terminal of the B battery. This resistance may be left permanently in the circuit without any effects whatsoever in the normal life of the receiving set.

Probably the most convenient form of resistance is a 25-watt, 100-volt tungsten lamp which will provide sufficient protection for plate voltages up to and including 100 volts. This resistance automatically increases with the current so as to act, in effect, as a protective ballast lamp.

**WE REPAIR**  
**WD-11, \$3.50**  
and OTHER  
VACUUM TUBES  
Excepting  
VT-I and VT-II  
MAIL ORDERS Solicited and  
Promptly Attended To  
**H & H RADIO CO.**  
516 Clinton Avenue NEWARK, N. J.

## Counterbalance for the Condenser Put in Dial

Most Radiophans like an easy and smooth turning condenser, but if there is no counterbalance (and most condensers have not) they will often sag when subjected to even only a small amount of vibration, with the result of fading signals or sometimes causing the set to oscillate. An easy way to avoid this is to place a counterbalance on the back of the dial. As practically all beveled dials have a hollow space in the back, it is a compara-

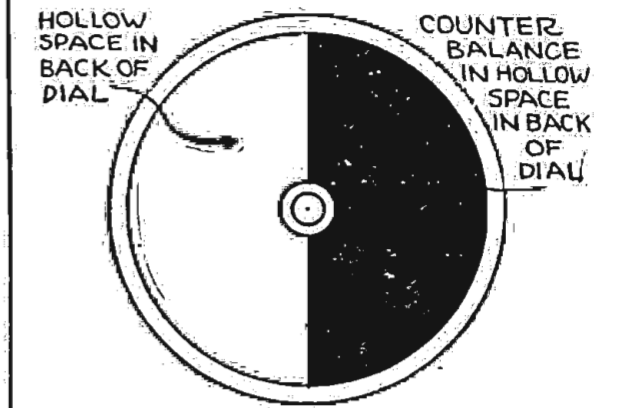

tively simple matter to add an effective counterweight, as shown in the illustration. It can be cemented or glued in place, or, if desired, the dial can be drilled and tapped for small machine screws.—Albert J. Madison, Portland, Oregon.

#### Distortion of Broadcast Waves

At the present time, broadcast waves can not be produced without some distortion. This is caused by the microphone diaphragm being more sensitive to the effect of some sound waves than to others.

#### PATENT ATTORNEYS

PATENTS. Booklet free. Highest references. Best results. WATSON E. COLEMAN, Patent Lawyer, 624 F Street, Washington, D. C.

**How to Make a Reinartz Receiver**  
Complete  
**BLUE PRINTS**  
for the construction of a Reinartz Receiving Unit and two step amplifier.  
INSTRUCTIONS FOR ASSEMBLY  
Description of apparatus and accessories and details of tuning.  
WINDING A REINARTZ COIL  
Cabinet Dimensions  
Panel Layouts  
List of Parts  
Send only money orders—no checks or stamps. Coins at your own risk.  
Book Department  
**Radio Digest**  
123 West Madison Street  
CHICAGO, ILL.  
**Only 50¢**

## PHANTOM-CIRCUIT

Build Your Own. This marvel of mystery, using no loop, no aerial and no ground, brings in music instead of interference. We have heard stations 950 miles distant on one tube. By using WD-11 tube set can be entirely self contained. Very easy to build from our instructions, use your own spare parts, nothing complicated like radio frequency or super regenerative. Only one tuning control. Complete instructions, with hookup and photo of circuit mailed to you for 60 cents. Stamps accepted. VESCO RADIO SHOP, Box D-704, Vacaville, Calif.

A NEW  
**Western Electric**  
**LOUD SPEAKER**  
**\$21.00** SEND MONEY ORDER  
DEALERS WRITE!  
C. W. THOMPSON COMPANY  
MATTOON, ILLINOIS

**WE SUBMIT THE PROOF**  
This letter is just one of hundreds received telling of the efficiency of the Wonderful B-Metal Loud Talking Crystal which enables many users to get loud talking results from ordinary crystal sets.  
We are prepared to send a photostat copy of the original letter to any one requesting it.  
B-Metal Refining Co.  
3134 Trumbull Avenue  
DETROIT, MICHIGAN  
Kaneas City, Mo.  
May 21st, 1923.  
Dear Sirs: I received your goods (B-Metal Loud Talking Crystal and Tube Detector) on the 18th and have given each article a thorough test from every angle, and I hereby give you my approval that the word supreme is the nearest mark of degree that I can think of for your Tube Detector and B-Metal Loud Talking Crystal. I am keeping the crystal, as it enables me to use a horn, making a crystal loud speaker that has the volume of a phonograph when using the soft needle. Enclosed please find money order for same. Yours,  
3431 Harrison St. W. R. Ferguson.  
Ask your dealer. He should have it. If not, send us your order and your dealer's name. Note the difference when you use a B-Metal Crystal, then tell your friends.  
**B-Metal Refining Company** 3134 Trumbull Avenue  
DETROIT, MICHIGAN  
Only 50 CENTS

# Another Simple Single Tube Reflex Circuit

## Operation and Characteristics of the Northern Electric 215A Tube

By H. J. Marx

EVER since the details of the smallest regenerative set appeared in the June 23rd number of Radio Digest, the fans have been requesting more information about this new miniature peanut tube. Where does it come from, who makes it, what are its features and a multitude of other questions have been asked.

This tube is put out by the Canadian Northern Electric Co. and known as type 215A. When imported in this country a duty must be paid, making it a little more high priced than the local dry cell tubes. Its distribution has not become very national as yet so many fans will still have trouble getting them.

### Filament Voltage

The filament voltage is 1.0 and the current consumed is 0.25 ampere. One dry cell will operate it but it is best to connect two in parallel so as to increase the ampere hour capacity. Dry cells are designed for intermittent service—lighting tube filaments is a steady drain that causes polarization of the battery. By increasing the number of cells and connecting them in parallel the proportionate drain on each cell is reduced and the batteries will give much better service.

This tube has a special socket, and requires an adapter when used with standard sockets. The usual six ohm rheostat can be used, no vernier adjustment being required.

### The Plate Voltage

The plate voltage as recommended by the manufacturer is 15 to 90 volts. The curves A, B, C and D are taken with the plate potentials at 16, 22½, 45 and 87 volts respectively.

This tube makes a very good detector but it will be found that when used as an amplifier the average audio frequency transformer will not permit good coupling because of its impedance value being different. Undoubtedly transformers will be placed on the market to work with this tube. Details of the construction of

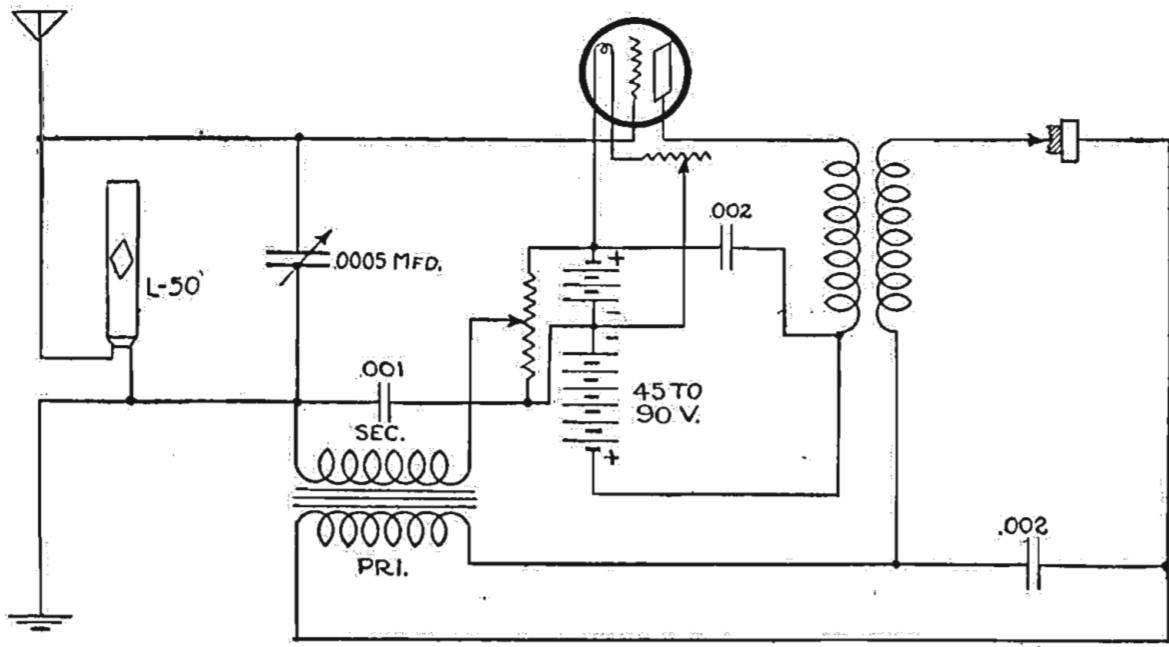

and clearest tones are heard, keep the voltage at that point. Some tubes require more than others.

### Three Controls in Circuit

The circuit has only three controls, one of which is the filament rheostat, so no instructions are necessary for tuning. It is the kind of circuit that anybody in the family can get hold of to listen in without a long list of instructions. Further refinements such as filament control jacks, battery switches, etc., can be added if desired. As it stands, the circuit is simple, inexpensive and presents opportunity for compactness and portability.

## SYMPHONY RECEIVER

(Continued from page 6)

An improvement over this type of feedback is the connection of a variometer between the aerial and plate circuit. This not only helps build up the volume but increases the selective tuning.

The upper illustration shows the front view of the set in its cabinet. The only connection made there is the plugging in of the loud speaker or head set in the jack of the particular stage desired.

The large dial on the left is the regenerative coupling dial and therefore controls the feedback to the plate circuit.

The tapped switch between the first and second dials is the control for the inductance adjustment for approximate wavelength value. The second dial from the left is the variable condenser which gives the fine adjustment for wavelength. If regeneration is not very pronounced, the inductance should be increased by advancing the tapped switch and decreasing the condenser capacity.

### Variometer Control

The third dial is the variometer control between the plate and antenna circuits. This will have a balancing action that will help clear up signals and bring out maximum volume.

Don't say rheostat—say

# FIL-KO-STAT

For REAL Filament Control

a Chi-Rad Special!



for W.D. 11 tubes—

Standard, threaded rubber, Willard's specially adapted for use with W.D. 11 Tubes. Supply current at 2 volts to one W.D. 11 Tube for 210 hours on a single charge. Rechargeable. Brand new, size 4x5½x7 inches—Chi-Rad guaranteed.

2-Volt Willard Charged... \$7.50  
2-Volt Willard Dry... 6.50

These same Willards can be adapted to deliver 8 volts for pure D. C. for C. W. Transmitters. Better than a generator because no filter is necessary. Much less expensive.

In lots of 40 (320 volts) \$160.00

(Better prices on larger quantity)  
Specify dry or charged when ordering.

Chicago Radio Apparatus Co.  
415 S. Dearborn St., Chicago, Ill.

Regeneration can then be increased up to the point just ahead of where distortion and howling starts. The variometer is then slowly rotated until volume is at its maximum. It may be necessary to try over at different tap settings for best results as this is dependent upon the antenna and ground system. Different tubes will necessitate different regenerative dial settings.

These variations dependent on apparatus and local conditions will alter preliminary tuning adjustments slightly and it is usually necessary for the operator to discover by experiment at what settings his set operates on.

### Range of the Transmitter

The necessity for long wave lengths, where great distances are to be covered, such as in transoceanic communication, is due to the fact that absorption of energy is much less on long wave lengths than on short wave lengths. The nature of the intervening country between transmitting and receiving stations is an important factor with relation to the strength of the signal and the distance it can be received, the greatest distance for a given amount of power being obtained over water. Lofty buildings with steel frameworks, or a section of country containing ore deposits absorb a considerable amount of the signal strength and consequently restrict the range of the transmitter. Communication during the winter months may be carried on with less power and greater reliability, due to the absence of serious electrical atmospheric disturbances.

Any six-volt automobile storage battery can be used for an "A" battery.

## Special Sets Made to Order

Let us quote you on any circuit. Sets made under expert supervision. We repair sets and test tubes.

FORBES RADIO CO.  
127 N. Dearborn St. Chicago, Ill.

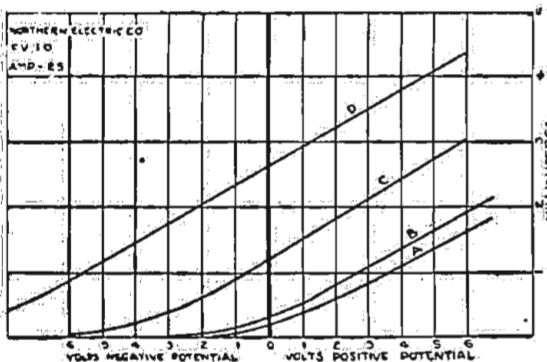

a home-made transformer for this tube will be given in an early issue.

### Adapted to Small Sets

Because of its small size it is especially adapted for use with very small compactly constructed sets. Another circuit which can be compactly constructed is the single tube reflex. In a circuit of this type, if it is not desired to use a loop aerial, a 50 turn honeycomb coil with a 23 plate variable condenser shunted across it makes a good simple tuning unit. A circuit of this type is shown in Figure two.

### Single Tube Reflex

The inductance can be any of the three following types, a fifty turn honeycomb coil, a fifty turn spiderweb coil, or fifty turns of No. 22 single cotton covered wire wound in a single layer on a tube 2½ inches in diameter. The tuning condenser should have a capacity of .0005 microfarads with a vernier control for close and accurate tuning.

Three by-pass condensers are necessary, one of .001 mfd capacity and two of .002 mfd. The potentiometer can be of any resistance between 200 to 400 ohms. The filament voltage depends on the type of tube used. The circuit is by no means limited to the 215-A tube. Any hard or amplifier tube can be used. The rheostat resistance depends also on the tube used. The series of articles on tube characteristics mentions the type of rheostat advisable to use with each tube.

The plate voltage is best determined by the operation of the set. When the loudest

## Electric Soldering Iron

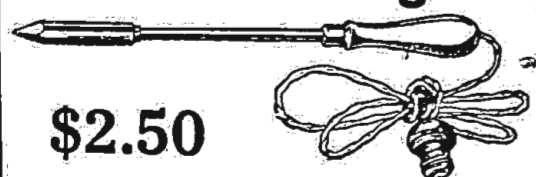

\$2.50

A. C. OR D. C. CURRENT

DEALERS—Attractive Discounts

NOTE: We are the Largest Exclusive Radio Jobbers in the Middle West

HUDSON-ROSS  
123 W. Madison St. Chicago



# Federal Standard

## Radio Head Sets

When you buy Federal Head Sets you obtain the lasting satisfaction that comes with Radio equipment universally endorsed by engineers and experts.

Years of experience in making communication apparatus enabled Federal to enter the Radio field with Head Sets and other Radio apparatus unsurpassed for efficiency in operation.

Permanent magnets, specially treated steel, and precision machining of metal parts are some of the outstanding features of construction that make Federal Standard Head Sets the best you can buy.

Ask your dealer for Federal Standard Head Sets. If out of stock he can get them from our nearest office.

Accept no substitute.

## Federal Telephone & Telegraph Company

Oldest and largest manufacturers of a complete line of Radio Equipment

Factory: BUFFALO, N. Y.

Western District Office: 417 South Dearborn St., Chicago, Ill.

### LONG DISTANCE HOOK-UP R.D.-90

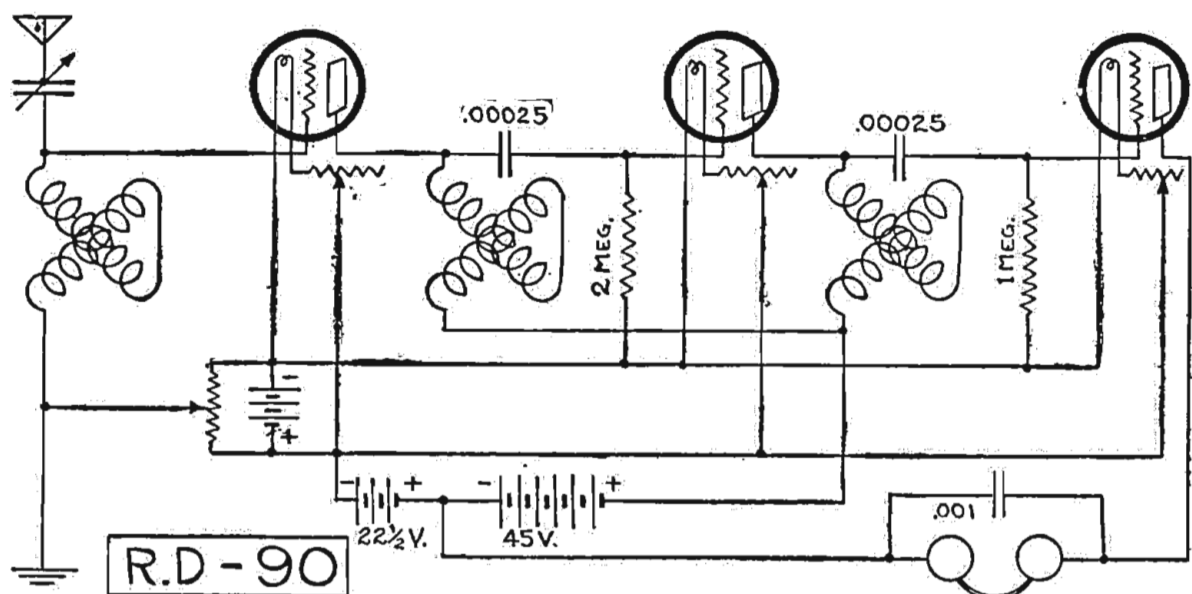

A TYPE of amplification little used, but giving very efficient results, is shown in the illustration as R.D.-90. The use of transformers in coupling is eliminated.

The necessary apparatus is limited and will permit construction at a very reasonable outlay of money.

Hard tubes are employed in the first two stages. The three variometers are of the lattice winding type, with minimum internal capacity. The wooden frame type are not recommended. The tuning unit consists of a variable condenser and variometer in series. A 200-ohm potentiometer is

used for controlling the grid potential of the first tube. The remaining two variometers control the plate circuits of the first two tubes. The addition of the grid leak keeps the grid at the proper potential by drawing off any accumulated charge. One rheostat can be used for controlling the first two tubes if desired.

Audio frequency can be added by hooking the primary of the A. F. transformer in place of the phone receiver. The circuit is well adapted for long distance reception. The simplicity of controls will help the amateur in rapidly acquiring the tuning knowledge.

### FIRST STEPS IN RADIO

(Continued from page 11)

and in many cases are not used at all. When the volume of sound is too great it is only necessary to slightly reduce the filament brilliancy to control the intensity of the signals.

#### Limit of Amplification

It is not practical to carry the amplification beyond two stages with apparatus as usually purchased for by the very nature of the amplifier it will increase the intensity of audible sounds that interfere with the signals being received. These sounds originate in many different ways and are often extremely difficult to locate.

A poor contact in any part of the circuit will give rise to disturbances and can only be guarded against by soldering all connections. Tubes loose in the socket, corroded prongs on the tubes, low B batteries, irregular emission of electrons by the tube filaments and even vibration of the tube elements give rise to interfering sounds that are greatly amplified and cause much annoyance. These various items should all be checked up when a set proves very noisy.

#### Squealing and Howling

Another source of great annoyance with audio frequency amplifiers is squealing and howling. This is due to the plate circuits feeding back into the grid circuits giving a regenerative action at audible frequencies. This can only be prevented by proper wiring and location of the instruments.

The transformers should be separated as far as practical and placed at right angles to each other. The wiring must be kept well spaced and not run parallel to any point and should always cross at right angles. Squealing in a set can often be prevented by reversing the leads to the transformer terminals, trying different arrangements till the trouble is eliminated. Jacks are a frequent cause of squealing and their removal will often cure a chronic case.

#### Other Methods of Coupling

So far we have considered only transformer coupling between tubes. Another method of coupling audio frequency amplifiers that deserves attention is impedance or choke coil coupling. This method of coupling was the first to be experimented with and work on it was stopped by the amateurs during the war but the army carried on the work and an efficient choke coil amplifier is possible of construction at a cost lower than with transformers. This should appeal to the Radiophan who must watch expenses closely and strange to say this amplifier will give just as good results as trans-

former coupling and with a little experimenting can be made even more efficient. A circuit employing this type of coupling is shown in Figure 45.

A fixed impedance is connected into the circuit in place of the transformer and a small fixed condenser inserted to prevent the positive B potential reaching the grids of the amplifier tubes. The grid condenser is shunted by a small grid leak to control the potential of the grids.

The action of this form of coupling is similar to the tuned or impedance coupled Radio frequency amplifier depending for its operation on the change in drop of potential across the impedance which is transferred to the grid of the next tube through the small fixed condenser.

#### Homemade Impedances

For the benefit of those who may care to experiment with this circuit some construction data might not be out of place. The impedances are made from Ford spark coils. Simply remove the vibrator and make connections to the secondary winding and the impedances are ready for use. It is not even necessary to remove the primary winding. The coils when mounted in the cabinet should be placed at right angles to each other and at opposite ends of the box. The values of the fixed condensers are given in the illustration but these values must not be taken as final. It is well to experiment a little, trying different capacities till the loudest signals are obtained.

The grid leaks may be homemade and of the simplest construction. The adjustment of the leaks is rather critical and should be carefully done while the set is operating. The important part in making up this amplifier is to make all leads as

### Summer Bargains

In the Highest Quality Radio Apparatus. Values That Will Open Your Eyes. Send for Our Free Booklet

RADIO & MECHANICAL TRADING CORP.

23 Warren Street New York City

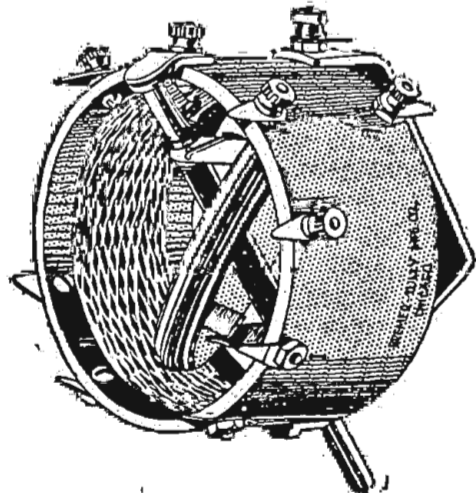

### THE NEW B-T VERNIER TUNER

Gives 100% Improvement on REINARTZ CIRCUITS. Does away with soldered taps, switch points, etc. Easy to change to other circuits if desired. Photo Diagrams furnished—ask your dealer, or write for circular.

"IT'S A BEAUT"

BREMER-TULLY MFG. CO.

532 South Canal Street CHICAGO

short as possible, particularly the leads to the grids of the tubes and for that reason do not attempt to use jacks in the circuit. The posts on the left of the circuit are to be connected to the phone terminals of the detector circuit, the condenser across them serving as a bypass for the Radio frequency currents when a regenerative receiver is used.

This type of audio amplifier when properly adjusted will be very efficient and not only give louder signals but be freer from stray noises. It takes a little patience but is well worth the trouble and will be found much cheaper than transformer coupled amplifiers.

(TO BE CONTINUED)

### Reviews of Books

**The Armstrong Super-Regenerative Circuit.** By George J. Eltz, Jr., E. E. This is a De Luxe edition of this famous circuit. Profusely illustrated and fully explained. Fifty-two pages. Price, \$1.00.

**Practical Amateur Wireless Stations.** Contains the best suggestions of thirty-three experimenters on building, installing and operating experimental stations for Radio communication. 136 pages illustrated. Price 75 cents.

**Prepared Radio Measurements.** It is not necessary to apply the "cut and try" method when you have this book at hand. The charts included in this book represent formulae that are apt to occur in ordinary Radio computations. Price \$2.

**Home Radio—How to Make It.** By A. Hyatt Verrill. This book is particularly adapted for the amateur who desired to know how to make Radiophones. Twelve full page illustrations and diagrams. Price, 75 cents.

**Elements of Radiotelegraphy.** By Elery W. Stone. The text was written for the guidance and instruction of Radio students in the communication service of the Navy. It is an instruction book for Radio schools. Price, \$2.50.

The book department of the Radio Digest is prepared to send you any of the books on Radio published, whether listed in our Book Review or not. Let us know what book you want, send us your check and we will see that the book is mailed to you. Postage stamps in payment for books not accepted. Send money order or check. Radio Book Department, Radio Digest, 123 W. Madison St., Chicago, Ill.

### New Condenser Symbol Showing Connections

The element of body capacity effect is an important part in tuning for the new fan. Inadvertently, he makes connections that increase his troubles. It is an important point to see that the rotating plates in a variable condenser are connected to the proper side of the circuit. For example, when the rotating plates are connected to the grid side of the secondary circuit, every time the hand touches the condenser dial it affects the grid action of the tube. The set may howl every time the hand is brought near the dial or after the station is tuned in and the hand removed from the dial the reception fades away or decreases in volume.

The ordinary variable condenser symbol does not indicate which side is the rotat-

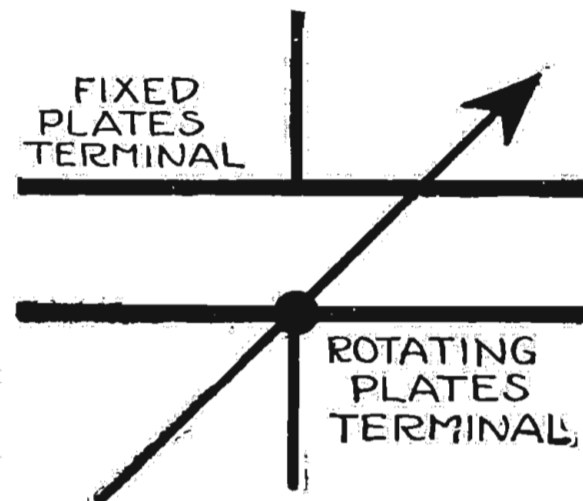

ing plate's terminal. In order to correct this omission and to help make the fans get the proper connection, the symbol shown in the illustration will be used exclusively. The location of the heavy dot at the crossing of the arrow on the plate line indicates that this is the rotating plate side. The fixed plate side has no dot, and the arrow does not cross at the intersection of the lead line. Watch for this in future circuit diagrams, and see that your condensers are connected correctly.

#### Locating Trouble

The trouble in many a homemade Radio set is often poorly constructed tinfoil condensers, pencil line leakage across the panel, poorly soldered joints or slight mistakes in wiring. It pays to use the best type of parts and to be very careful about leakage and soldering.

## Our Latest Triumph

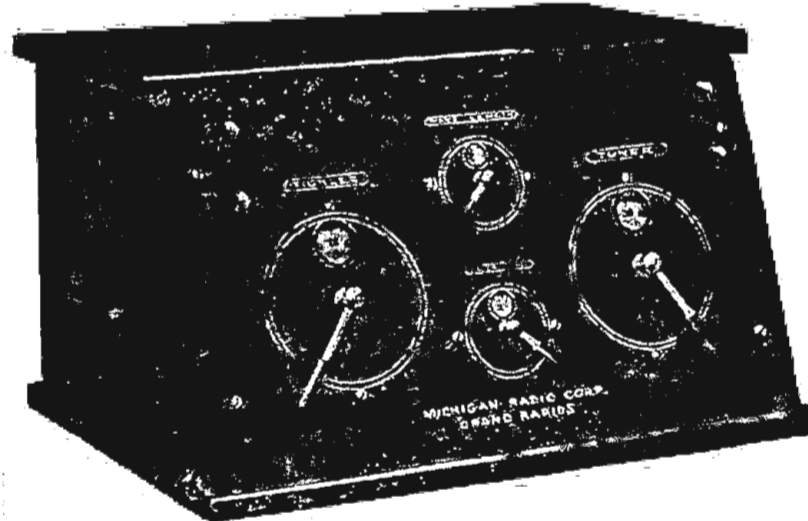

### The Michigan

"Midget"

\$27.00

### Long-Distance Wonder Worker That Tunes Out Local Broadcasting

The most dependable long-distance Receiver ever assembled in so small space. Convenient for campers and tourists, yet equally suited to home use the year-round. Handsome mahogany finished cabinet 14 1/4 in. long, 7 7/8 in. high, 9 5/8 in. deep at base.

Operates with any of the dry cell tubes as well as with standard 6 volt tubes. Cabinet will hold three No. 6 dry cells and 22 volt "B" Battery.

Levers in place of dials make tuning easier and accurate. Wonderfully clear, pure-toned reception through headphones—add two stage amplifier for loud speaker reception. A Radio Engineering triumph.

Price, without tubes or battery, F. O. B. Grand Rapids, \$27.00.

Ask your dealer. If he cannot supply you, remit to us and send his name and address.

Send for list of Michigan Quality Radio Receivers and Parts; variometers, variocouplers, all-range couplers, special rheostats—50c, potentiometers—200 ohm and 400 ohm—60c, etc.

Dealers, the set you have been waiting for to make complete package "over the counter sales."

## MICHIGAN RADIO CORPORATION

GRAND RAPIDS, MICHIGAN

### Why Pay More?

#### GENUINE R. C. A. TUBES

WD-11 \$5.95 UV-199  
WD-12 UV-201A

ALL NEW—NO STAMPS, CHECKS, C.O.D.

BALDWIN PHONES \$9.75

Send for Our New Price List with Hundreds of Other Items.

SAVE MONEY ORDER FROM US

### Cut Rate Radio Co.

P. O. Box 472 Newark, N. J.

# Questions and Answers

### Rectifier Details

(2839) EHT, Concord, N. H.  
 Kindly give winding directions for a transformer as follows: Kind of core, primary winding for 110 volts, size of primary wire, number of turns, secondary winding number of turns and size of wire? Are the windings wound over one another as in an auto transformer? Is it possible to use soft iron wire to about 1 inch in diameter as a core?  
 Can this be used in the place of B battery on the regular super set and also on the amplifier by using UV-202 5-watt tubes to stand up to 350 plate voltage or will I have to use some other source for the super and this transformer rectifier for the amplifier alone?  
 A.—The usual silicon iron laminated core is used for the transformer. Primary consists of 440 turns of No. 18 D.C.C. wire and secondary of 880 turns of No. 22 D.C.C. Advise winding on standard closed core frame.  
 You should be able to use this in place of B battery with UV-202 or 5-watt tubes, as suggested.

### Crystal Detector Circuit

(4132) IN, San Francisco, Cal.  
 I have bought parts to make a small crystal set and I have put them together, but I do not get a sound of music; sometimes static. Enclosed you will find a diagram of my parts and hook-up (diagram given). If you will help me out I will be much obliged to you.  
 Do you think the matter lies in the variable condensers? Are the number of plates correct?  
 Could I discard the tuning coil and use a variocoupler or a molded coupler?  
 A.—Noting diagram submitted we are advising that it is correct in detail. It is possible that your limitations are due to an ineffective antenna system. This should

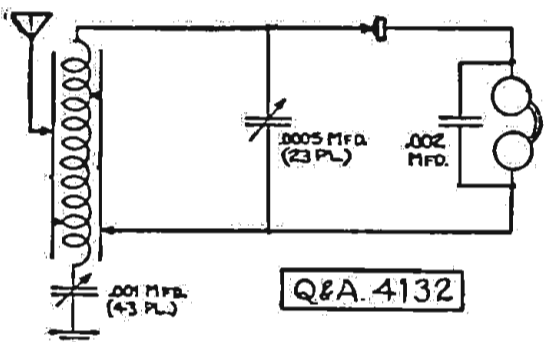

consist of a single wire accomplishing 150 feet, including lead-in, with an adequate ground. It might be due also to an insensitive crystal. A phone condenser is not indicated in crystal detector circuit necessarily. Possibly these suggestions are all that are necessary to follow to accomplish satisfactory reception.

### Body Capacity

(2379) HDH, St. Paul, Minn.  
 I have constructed the regenerative tuner and detector panel as described in Radio Digest issue of Dec. 16, 1922, page 11, by A. C. Tabbot.  
 With this set I have heard Chicago, Schenectady, Atlantic City, St. Louis, Davenport and others, but still I am having my troubles, and therefore I am writing this for help. I am using a 1 1/2 volt WD-11 tube with a 22 1/2 volt variable B battery and no condenser across tickler. I use a variable Freshman grid leak and all is mounted on a wooden panel well shielded and grounded. My trouble is noises of which there is every description imaginable when tuning for long distance. On local reception the set works fine, but I cannot tune out the noises on long distance.

Immediately upon approaching or leaving the panel it howls. I have found that by clamping the receiver cords tightly in my hands I get clear reception for a while and then all at once it sounds as if a lot of coal is rolling down a chute and my station is lost. My aerial is two wire 40 feet long and 30 feet high, which I am

the proper constants for them and their location in the circuit?  
 Would like to know what you have to say regarding the effective range of this set on a loop and also with aerial and ground?  
 We have a rather peculiar condition to contend with here. Our municipal light-

arrangement is altogether desirable for best results. Range with loop antenna is more or less conjectural. However, we are directing your attention to the diagram appearing in January 27 issue of Radio Digest as preferable to the one you have cited.  
 Either a .0005 mfd. or .001 mfd. variable condenser will serve. .0005 capacity is preferable.  
 A variocoupler as connected in the second part of diagram one is used for outside antenna and ground, as indicated.

The Question and Answer department is purely a service department and the publishers would like to have your assistance in helping to keep it up to the highest standard, therefore when asking questions please make out your query on a separate piece of paper and written on one side only. Do not mix your questions with other material, write that on a separate piece of paper. Each one must go to a different department. Then, too, we have so many who fail to put their name and address on each sheet. Please remember this when you write your letters, and also to enclose a stamped self-addressed envelope. Unsigned letters are not answered.

going to change to a single wire, and have wondered about the wooden panel, but have been told that this should have no effect.

Is the three plate condenser across the tickler necessary to stop the noises and should I use a vernier rheostat? What transformer and what ratio is best for WD-11 tube, as I intend to use two stages if I can get my set to operate properly. I would be one happy amateur if you could lead me out of my predicament, and I think you can.

A.—Noting your specifications and difficulties encountered will advise that it is indicated that your trouble is due to body capacity effect. The wooden panel does not in any way prevent the reception of signals. Body capacity effect is materially reduced by shielding panel and grounding shield, as you have done, also by grounding minus A battery as well. There is no other known method for eliminating body capacity.

A twenty-three plate vernier across the secondary of your coupler will be more effective than in any other position in set. It is doubtful if a vernier rheostat will have any material value.

For amplifying transformer use a ten to one ratio on first and three or four to one ratio on second stage of audio frequency amplification.

Referring again to body capacity effect, it is one of the bugbears of reception and is peculiar to regenerative sets. Shielding in itself considerably reduces efficiency so that it is resolved to a question of enduring of two evils the lesser.

### Reflex Circuit

(3030) FCW, Austin, Minn.  
 Will you be so kind as to give me a little additional information in regard to reflex circuit hook-up given in Figure 1, published in Radio Digest of January 20, 1923?

The diagram shows a variable condenser of .0005 mfd. capacity for tuning, while the text calls for one of .001 mfd. Which is correct?

I take it that the diagram, as drawn, contemplates the use of a loop only. If aerial and ground are used, what additional pieces of apparatus are necessary.

## Kellogg Radio Equipment For Better Results



### VARIOCOUPLER

The Kellogg variocoupler is of the same standard design as our variometer, being made of molded Bakelite, with reinforced construction.

For increasing the wave length from 500 to 2,500 meters, the Kellogg standard wound induction is added to the variocoupler.

It is arranged for either panel or base mounting. No. 501 Variocoupler . . . . . \$9.00

With No. 502 Diamond Wound Coil, as shown in illustration . . . . \$13.00

Kellogg Switchboard & Supply Company  
 CHICAGO

ing system is in a bad way, insulation in many instances hanging from the outside wires in streamers, transformers often overloaded, frequent "shorts" and "grounds." Of course all of this is reflected in our sets using only A. F. amplification. We often have to quit entirely, as a steady buzz of considerable volume drowns out our signals.

What many of the local fans wish to know is, whether or not R. F. amplification would cut out some or most of this interference, and whether or not the reflex circuits are practical. Of course we know that the directional qualities of a loop would help to cut out interference from any certain direction, but most of the fans want a set with which they can cover the longer distances, and would still like to use the outside aerial.

A.—It is not our opinion that either this circuit or the employment of Radio frequency amplification will serve to cut out any of the interference cited, neither will they tend to reduce it. The only effective plan that suggests itself to mind is that of attacking the annoyance at its source.

Under normal conditions the reflex circuit should serve you effectively. Its range with outdoor antenna and ground approximate one thousand miles. This

### Antenna Circuit

(3053) FEM, Chicago, Ill.

Living in an apartment building I am compelled to use a lead-in from my antenna, which comes down an inside air shaft, and the length of the lead in is about 75 feet. What length of antenna to use on the roof? I have tried one 125 feet long and get local reception loud, but cannot tune it out. I also have tried two 40-foot wires, but do not get the same volume. I have two variometers and a coupler, and use a 43-plate condenser on the ground. Should this be shunted between the ground and the antenna?

A.—Noting your specifications and difficulties experienced we are advising a seventy-five foot antenna, a single wire on roof, lead-in to be taken off the end nearest the set, not from the center.

Antenna condenser is placed properly as you now have it.

The set you have is efficient and selective. You should have no difficulties in the matter of interference, generally speaking.

The Massachusetts Federation of Women's Clubs broadcasts, through station WGI, talks and instructions in house-keeping, cooking, marketing and domestic science.

**WE REPAIR YOUR VACUUM TUBES**  
 WD-11, WD-12, UV-199, UV-201-A, C-301-A . . . . . \$3.50 each  
 UV-200, C-300, AP Detectors . . . . . 2.75 each  
 UV-201, C-301, AP Amplifiers . . . . . 3.00 each  
 DV-6, DV-6-A . . . . . 3.50 each  
 UV-202 . . . . . 4.00 each  
 And Guarantee Them Equal to New  
**QUICK SERVICE** include with your order remittance to cover repair plus parcel postage for one pound per tube.  
**Abalene Radio** 14 Vesey Street  
 New York, N.Y.

# Your Choice

## Bound Volumes FREE

Numbers Two, Three, or Four  
 Postpaid by Parcel Post with One Year's Subscription to Radio Digest

Supply Limited

Radio Digest Illustrated  
 Volume 2  
 Reinartz Flewelling  
 Circuits

Radio Digest Illustrated  
 Volume 3  
 Reinartz Flewelling  
 Circuits

Radio Digest Illustrated  
 Volume 4  
 Reflex, Remote  
 Flewelling

Greatest Collection of Radio Information Ever Published

Reinartz Long Distance Circuit  
 Ultra-Reinartz Circuit  
 Flewelling "Flivver" Circuit  
 Grimes "Inverse Duplex" Circuit  
 Single Tube Reflex Circuit  
 Armstrong "Super-Heterodyne" Circuit  
 Two, Three and Four Tube Reflex Circuits

A. B. C. Lessons for Radio Beginners  
 In addition to these features these volumes contain many instructive articles, receiving set diagrams, how to make articles, new apparatus, pictures and illustrations, hook-up diagrams, broadcasting stations, technical articles and book reviews.

13 Numbers in the Bound Volume  
 52 Numbers in Year's Subscription

**65 Numbers**

VOLS. TWO, THREE & FOUR  
 Now Ready for Delivery. Parcel Post Prepaid. Each, Only \$2.00  
 On account of the limited supply, the sale of these bound volumes is limited strictly to those readers of the Radio Digest who have subscribed for a year. One year subscription to Radio Digest and both bound volumes . . . . . \$7.00  
 2 and 3 or 3 and 4 . . . . . \$9.00  
 By subscribing now for one year to the Radio Digest you get both BOUND VOLUMES 2 and 3 or 3 and 4, 26 numbers, with 1 year's subscription, for \$7.00  
 One year subscription to Radio Digest and bound volumes 2, 3 . . . . . \$9.00  
 ALL ORDERS MUST BE SENT DIRECT—No orders on this offer will be accepted through subscription agencies, news dealers or other sources. Check, money or express orders (no stamps) must accompany all orders.

**COUPON** 7-21  
 PUBLISHER, RADIO DIGEST,  
 123 West Madison St., Chicago, Illinois.  
 Please reserve me Bound Volume Number Two and also Number Three and one year's subscription to the Radio Digest, for which I am inclosing check—M. O. for Seven Dollars.  
 Please reserve me Bound Volume Number Two or Three or Four and one year's subscription to the Radio Digest, for which I am enclosing check—M. O. for Five Dollars.  
 Name . . . . .  
 Address . . . . .  
 City . . . . . State . . . . .

**FORMICA**  
 A Laminated Phenolic Condensation Product  
**SHEETS TUBES RODS**  
**RADIO PANELS**  
 POLISHED BLACK FINISH

CUT PERFECTLY SQUARE TO ANY SIZE

1/32" THICK	1/2¢	PER SQ. INCH
1/16" THICK	3/4¢	PER SQ. INCH
3/32" THICK	1¢	PER SQ. INCH
1/8" THICK	1 1/2¢	PER SQ. INCH
3/16" THICK	2¢	PER SQ. INCH
1/4" THICK	2 1/2¢	PER SQ. INCH
3/8" THICK	4¢	PER SQ. INCH
1/2" THICK	5 1/4¢	PER SQ. INCH

SEND FOR COMPLETE PRICE LIST  
 PROMPT ATTENTION TO MAIL ORDERS  
 DEALERS PRICES ON APPLICATION

**STARRETT MFG. CO.**  
 519 SOUTH GREEN ST. CHICAGO





Illustrated

Daphne Pollard, English Actress, and her infant son listening to a Radiophone concert in her dressing room at the London Theater, London, England.  
© London Mail

This tiny crystal receiving set is so small that it will fit in the palm of a hand. Its range is 25 miles.  
© K. & H.

The 700-year old turtle in the Bronx Zoological Park, New York, seems to be pleased with the Radio music. Dr. Raymond Ditmars, and the head keeper, John Toomey, observed the actions.  
© K. & H.