

Neutralizing the Super-Regenerator Circuit; Gold Cup Award Stanungs, Operating Regenerative Receivers; Erecting Staffs for Aerial Wire Ends

Radio Digest

EVERY WEEK **Illustrated** TEN CENTS

REG. U. S. PAT. OFF. & DOM. OF CANADA

Vol. X

Copyright 1924
By Radio Digest Publishing Co.

SATURDAY, AUGUST 23, 1924

No. 7

TALK DAILY TO ENGLAND

UNIQUE PROGRAM ON ANNIVERSARY

Second Year in Existence Celebrated by Boston Station

BOSTON.—Station WNAC, located in this city, recently held an anniversary program, as the station was two years old. Many who appeared on the first program Radiocast from WNAC, together with many of the favorites of the station, appeared on this famous program.

Major John J. Fanning, who has been director of the station since it's opening, and whose beloved voice has said many a cheery "Good-night" to the invisible audience many hundred times, was in charge of the program and announced as usual.

Looking over the past year it would be difficult to pick out high lights from the programs that have been Radiocast from WNAC, but notable among them were grand opera, pops, opening nights at musical comedies, straight comedy, etc.

Mr. John Shepard, III, who has been the one to give to Boston as well as New England and other places this splendid Radiocast service, gave a short talk, and was followed by many other notables from Boston and the vicinity.



Above is shown Thalia Zanou, as the "Gollivog" at the zoo frolic, given every Monday night from Station WLW, at Cincinnati. To the left is shown Baby Hellen Lorraine, noted stage beauty, who recently Radiocast from Station WOR.



Bob Emery Resigning Entertains WGI Fans

"Joy Spreader" Loses His Famous Miami "Tiple"

MEDFORD HILLSIDE, MASS.—Entertaining WGI fans for the last time, prior to his connection with Station WTAT, soon to be WEEI of Boston, C. R. (Bob) Emery had planned to sing some songs to the tune of his new Miami tiple, but he did not!

Just before the program was started his tiple disappeared as either lost, strayed or stolen. So he went on the air with his ukulele instead, in his old familiar role of "Joy Spreader."

To those unfamiliar with the Miami tiple may be said that it is an overgrown uke, strung with ten strings instead of four, but tuned exactly the same as a ukulele. The one Mr. Emery had, had been especially constructed and was a replica of the one now used by Wendell Hall, now touring the Pacific coast states.

USING NEWEST SHORT WAVES FROM KDKA

Station Built on Hills Near Wilkensburg, Has 100-Kilowatts Maximum Power

Heard in Buenos Aires

Talks in Spanish to South America Each Day—Uses Special Equipment

E. PITTSBURGH, PA.—Have you a short wave receiver? If so, have you heard a strange tongue coming in, pretty loud on various wave-lengths close under 100 meters?

If you did hear the foreign talk given at noon when the sun was beating down hard and willing collars right and left, perhaps you recognized it as Spanish and learned that KDKA, Westinghouse Radiocast station here, was talking direct to Buenos Aires.

Using approximately seven kilowatts (7,000 watts) of energy in its special new short wave antenna system, KDKA has been doing consistent noon-day Radiocasting to Buenos Aires and England.

Set Has 100 K. W. Reserve

The newly built short wave transmitter on the hills near Wilkensburg, has a maximum power of 100 kilowatts. Westinghouse engineers have built the immense equipment with the sole purpose, it is said, of learning all there is to know about short wave transmission and reception. At the same time the apparatus can always be used for trans-Atlantic, trans-Pacific and transcontinental Radio telephony.

Plans also call for the installation of a 325-meter wave length station, adjoining the short wave outfit, and capable of delivering 250 kilowatts (250,000 watts) to its antenna. It will not, however, under the present law be used for regular Radiocasting, as a maximum power of

(Continued on page 4)

NEW STEEL GIRDERS AFFECT WCX WAVES

DETROIT.—The construction of steel skeleton buildings doesn't mix well with Radiocast stations, especially when the steel workers add beams from day to day. WCX, the Detroit Free Press, according to M. R. Mitchell, has had to retune its antenna each day during the recent building of a skyscraper adjoining the Free Press building. Every new beam placed altered the WCX wave, which then had to be corrected.

No. 14 OFFICIAL BALLOT

Announcers' Contest

RADIO DIGEST FIRST ANNUAL GOLD CUP AWARD

Gold Cup Award Editor, Radio Digest,
510 North Dearborn St., Chicago, Ill.

Please credit this ballot as one vote for:

..... of Station.....
(Announcer's name) (Call letters)

Signed.....

Address.....

City..... State.....

If you desire, tell below in five or less words what you most like about the announcer for whom you have cast this ballot:

GOLD CUP STANDING CHANGES SLIGHTLY

WRITTEN IN FOURTH PLACE;
2-LO NOW IN CONTEST

Leaders Now Eighteen Votes Apart;
Three Names Added to List;
Two More Ballots

With only two more ballots to go, the votes are beginning to come in large numbers. George Hay, WLS, still holds the lead, with his namesake—no relation whatsoever—Bill Hay, KFKX, only eighteen votes behind, pushing him hard.

Three new members have jumped up into the list of leaders during the week, and each one wishes to state that he is a strong antagonist one who has to be reckoned with when it comes to the final showdown. They are as follows: Jerry Sullivan, WQJ, who now has 68 votes; C. W. Kirby, WWJ, 53 votes, and last but not least, Art Burroughs, 2-LO, London, England, with 52 votes.

English Announcer Enters
Art Burroughs is the only announcer among the leaders who hails from outside the United States. Announcers have been nominated in Porto Rico, Mexico and Cuba, but they are not yet among the leaders.

Another nominee who has jumped ahead is J. M. Witten, WOS. Last week he was in fifth place, but now he is in fourth place, while the Hired Hand has taken Witten's former position. No more new nominations have been received, and from the looks of things any announcer who is not listed had better step lively. Sixteen consecutive ballots entitle the holder to a bonus of seventy-five votes beside the sixteen for the original ballots. While twelve consecutive votes are given a bonus of fifty votes. Remember this when sending in votes and get as many in succession as possible, thereby getting the benefit of the additional bonus.

Don't forget that all votes must be in the mail by September 8, at the latest. Any votes mailed after this date will not be eligible toward your favorite announcer.

When the final result is published, we will also tell just what requirements are desirable for an announcer to have. This will be the consensus of public opinion taken from the ballots received.

Latest Standings

The standing of the contestants on August 8, with fifty or more votes to their credit, is as follows:

Name	Station	Votes
George Hay	WLS	6,420
Bill Hay	KFKX	6,402
Leo Fitzpatrick	WBAP	5,337
J. M. Witten	WOS	4,642
Hired Hand	WBAP	3,234
Graham McNamee	WBAP	2,108
H. W. Arlin	KDKA	1,981
John Daggitt	KH	1,739
Jack Nelson	WGN	1,739
Richard Haller	KGW	1,738
Fred Smith	WLW	1,563
S. W. Barnett	WOC	1,244
H. E. Ehrhart	WDR	1,197
Lamhdin Kay	WSB	1,195
Major J. J. Fanning	WNAC	1,062
Gene Rouse	WQAW	920
Sen Kandy	WGY	737
Elmer Johnson	WJAX	694
Kolin Hager	WGY	681
E. W. Tyson	WWJ	552
Major Andrew White	WJZ	476
N. D. Cole	WHO	416
Miss V. A. L. Jones	KSD	354
J. T. Schilling	WGN	341
Milton Cross	WJZ	331
A. E. Hersie	WTAM	326
S. L. Rothafel (Roxy)	WEAF	312
Jennings Pierce	KGO	308
Howard Milholland	KGO	303
Joseph Sartory	WCAE	298
Paul Johnson	WLAG	282

Otto Becker	WGR	278
A. O. Coggesill	WGY	276
N. T. Granlund	WHN	262
Paul Reese	KFI	251
C. R. Emery	WGI	244
Henry Fleid	KFNP	224
C. A. Bntrekin	WCAH	222
A. P. Edes	WBZ	215
F. A. Buhler	KFIC	208
Harold Selver	WHAS	198
Eleanor Pochler	WLAG	183
Chas. H. Meester	WCBR	171
F. W. Johnson	CHYC	168
John Reilly	WJAR	160
Win. P. Holliday	WWJ	155
Johnnie Mack	WJAS	155
C. D. Tomy	WCX	152
Chas. Erbstein	WTAS	151
C. A. Gaal	KUS	145
Wm. Ludgate	KSD	142
Morgan Eastman	KYW	140
J. Lewis Reed	WJZ	140

GERMAN INVENTS NEW RADIO TUBE

Filled with Acid Instead of Being a Vacuum; Contains Three Electrodes

BERLIN.—The idea, proposed a year ago of a detector tube filled with a colloidal liquid has been revived by a recent invention in which the "triode" contains a solution of the iron salt of gallic acid. This material is said to be the same as the compound formerly used in the old-fashioned black inks made of iron and oak galls.

The solution of iron and gallic acid is a colloidal solution, which means that it contains innumerable tiny particles, finer than the smallest specks of dust. These particles are said to carry the currents through the tube just as the electrons do in the ordinary vacuum tube. The tube contains the usual three electrodes, corresponding to the filament, the grid, and the plate. It is unnecessary, however, for the filament electrode of the new tube to be heated or to serve as a source of electrons. No A battery is necessary, although the high voltage B battery is used as in ordinary tubes.

It is said that the new solution of iron and gallic acid is a great improvement over the colloidal solutions used in previous liquid-filled detectors, which solutions were mainly either silver or sulphur. Experimenters are reported to be enthusiastic over the behavior of the new iron and gallic acid tubes, especially when used as detectors for the reception of local stations.

Victor Martin	WHAM	130
R. P. Falcon	PWX	128
E. A. Greene	WSAI	121
Gilson V. Willetts	WOC	78
Jerry Sullivan	WQJ	68
Walter Wilson	KYW	62
John T. Griffin	WLAH	58
John F. Patt	WDAF	56
Carl Mentzer	WHAA	54
C. W. Kirby	WWJ	53
Art Burroughs	2-LO	52

CONTENTS

Radio Digest, Illustrated, Volume X, Number 7, published Chicago, Illinois, August 23, 1924. Published weekly by Radio Digest Publishing Company, 610 North Dearborn Street, Chicago, Illinois. Subscription rates, yearly, Five Dollars; Foreign Postage One Dollar additional; single copies, ten Cents. Entered as second-class matter at the postoffice at Chicago, Illinois, under the Act of March 3, 1879.

"All the Live News of Radio".....	1 to 6
"Dream Daddy" and His Composer Aid.....	6
Neutralizing the Super-Regenerator Circuit, Part I—The Circuit Used and Description of Parts, By C. E. Butterfield.....	7
An Evening at Home with the Listener In, a chart to show when to listen in for your favorite station.....	8
Programs for the Week at the Larger Stations.....	9 to 12
Thirty-Minute A-B-C Lessons for Radio Beginners, Chapter XXI—Choosing a Radio Outlet, By E. E. Edelman.....	13
Editorials; Ind-Gst; Condensed by Diectric.....	14
Proper Operation of Regenerative Receivers, How to Avoid Annoying Your Neighbor, By A. K. Phillippi.....	15
Breeding Staffs for Aerial Wire Ends, Aerial Repairing Made Easy with Lift Support.....	17
Questions and Answers.....	18
Radio-Phone Broadcasting Stations, Part III.....	19
Radio Illustrated, a page of pictures.....	20

Looking Ahead

New Single Circuit for DX Reception. Benjamin Chew tells how he made a sensitive set with the addition of a hard tube in a reflex circuit. The circuit is not susceptible to static, and messages come in better than with the ordinary two tube set. Buy the next issue and read this.

Neutralizing the Super-Regenerator Receiver. The following article in this series tells of the panel layout and mounting the instruments for the set.

Batteries Require Plenty of Attention. A comprehensive discussion on the most essential part of a Radio set will be a feature in the August 30th issue. Details will be given on how to keep batteries in the right condition to get the best results.

Making Your Own Radio Set, will be the next topic in the series by Mr. Edelman on the A-B-C of Radio. Soldering, panel layout and other valuable information on the making of a set will be given.

Gold Cup Award Standings will be shown in the coming issue, and as the end of the contest is drawing near many unexpected surprises are looked for. With only two more ballots to go, its look like a close race.

E. T. Flewelling Begins New Series of Articles Soon. Watch for the latest articles by this noted Radio engineer. Writing exclusively for Radio Digest, he will tell of his new circuit which picked up London, on one tube

Take Radio Digest with You on Your Vacation

WHEN YOU WANT

Radio Digest

YOU WANT IT!

BE SURE OF YOUR WEEKLY COPY BY SUBSCRIBING NOW

SEND IN THE BLANK TODAY

Publisher Radio Digest,
510 N. Dearborn St.,
Chicago, Illinois.

Please send enclosed check M. O. for Five Dollars (Six, Foreign), for One Year's Subscription to Radio Digest, Illustrated.

Name.....

Address.....

City..... State.....

Complete Radio Satisfaction



Crosley Trirdyn 3R3

This three tube receiver is built to give the efficiency of a five tube set. It represents the triumph of excellence in the radio field. The first tube furnishes non-oscillating, non-oscillating radio frequency amplification. The second tube is a regenerative detector and further in so coupled up as to reflex back on the first tube for one stage of audio frequency amplification. The third tube furnishes a second stage of audio frequency amplification. Thus the three great powers in radio, represented by the three "R's," Radio Frequency, Regenerative, and Reflex, give both the name and the wonderfully efficient performance to this Crosley Trirdyn 3R3.

\$65

CROSLEY Better-Cost Less Radio Products

In the complete Crosley line are receiving sets to satisfy every pocketbook and preference covering a purchase range from

\$14.00 to \$120.00

All Crosley regenerative sets are licensed under the Armstrong U. S. Patent No. 1,113,100. Every Crosley receiver is a leader in its line. You are assured of satisfaction when you purchase a Crosley.

See the complete Crosley line. For Sale by Good Dealers Everywhere

The Crosley Radio Corporation

POWEL CROSLEY, JR., President
8494 Alfred Street Cincinnati, Ohio
The Crosley Radio Corporation owns and operates broadcasting station WLW

Hansen "BIRD-CAGE" Radios



4 Tube Radio Set \$32.50
Without Accessories

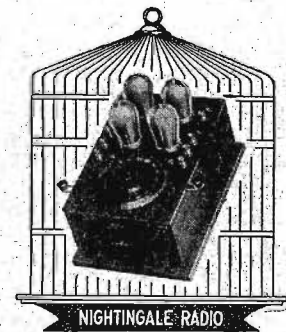

A simplified, loud speaking, long range set at a price within the reach of all.	
Hansen BIRD-LINK.....	\$25.00
2 Tube Reflex.....	
Hansen CARDINAL.....	\$50.00
3 Tube Reflex.....	
Hansen BLUE BIRD.....	\$57.50
4 Tube Radio Frequency.....	
Hansen MOCKINGBIRD.....	\$90.00
6 Tube Long Distance Loop Set.....	

Write for New Catalogue
Dealers and Jobbers—Our line is interesting and profitable.



DISTRICT DISTRIBUTORS
Badger Radio Co., Milwaukee, Wis.
Phil Cross Hov., Co., Milwaukee, Wis.
Gardner Elec. Co., Milwaukee, Wis.
Maxwell Elec. Co., Toledo, Ohio

NEW FUND STARTED RADIO IN HOSPITALS

"ROXY AND HIS GANG" BE- GIN NOVEL IDEA IN EAST

Sweeping Country from East to West;
Want Receiving Set in Every
Veterans' Hospital

NEW YORK.—Once in a century or so, an idealist starts something which gains momentum and size as it is pushed along, like the formation of a gigantic snow ball. This century it was the idea of S. R. Rothafel, of the Capitol theater in New York, who thought it would be a boon to sick and injured war veterans if they could hear an occasional Radio concert.

Roxy, to use his popular name, was well known in the east, when he conceived the idea a few months ago; now he is known on the other side of the Mississippi, and the snow ball, which he started is rolling toward the Pacific coast. It is so large and solid it is not likely to melt before some 200 hospitals are equipped.

Receiving Sets for Veterans

His idea has been accepted by the whole country, and a national committee, including the heads of several governmental departments at Washington, together with admirals and generals, has just completed a plan to equip every hospital in the United States, where ever a single war veteran is quartered, with Radio receiving facilities. Cities, communities, Radio-casters, newspapers, manufacturers and practically everybody has promised co-operation, and to date hundreds of thousands of dollars are collected or pledged. The aim of the national committee is to raise a million dollars, through the aid of state and municipal committees, the funds to be used solely for equipping local hospitals where veterans of the world war are being cared for. Both the heads of the army and naval medical services have endorsed Radio as an efficient aid in the recuperation of government patients.

Turn Idea to Government

Soon it was discovered that the scheme was taking everywhere; the burden of the work became too great for "Roxy and his gang," and he appealed to Maj. General Lejeune, commandant of the U. S. Marine corps, his former commander. Today practically the whole government is behind the plan. The executive committee has established national headquarters of the "Roxy Radio Fund," in the Munsey building at Washington, D. C.

Surveys of 160 hospitals east of the Mississippi river are already completed or are under way, in order that the individual needs may be in hand when the local district committees complete their canvasses for funds with which to purchase equipment.

The survey itself is now reduced to a simple form, due to the activities and forethought of the experts of the national committee. A standard form of Radio specifications has been adopted, based upon the Walter Reed equipment. A blank form is sent to each hospital, and the data filled in by an attaché. He specifies how many patients, what facilities for a central receiving room are available, method of wiring, and the length of wire necessary. To aid him he has the standard specifications and a model wiring diagram of everything from the antenna to the head phones and ground.

Shenandoah Airship Gets Compass Bearings in Air

NEW YORK.—During the recent flight of the Naval Air Cruiser Shenandoah, the first use of the Radio compass bearings by an airship was made and proved successful. While near this city, the Shenandoah encountered heavy fog and asked the New York harbor Radio compass stations for her bearings. A three point fix or bearing was received, and, while not absolutely accurate, it was sufficiently accurate for any aircraft operations, the commander of the Shenandoah reports.

RADIO IS LANGUAGE EVERYBODY TALKS

ROME.—A gentleman in this city went into a store the other day to buy a pair of shoes. As the clerk bent-over to lace them, he wanted to know if the purchaser desired them laced criss-cross, or horizontally like a football. "How will you have the shoes laced, sir," he asked, "in series or in parallel?" This goes to show the hold that Radio is taking upon the public.

STATION WHB HEARD IN MOJAVE DESERT

KANSAS CITY.—An engineering corps, experimenting in the Mojave desert, long considered a "dead spot" for Radio reception, has announced that Station WHB, located in this city, has been heard in the noted spot. The experimenters are located on a high, sandy, dry plateau, surrounded by mountains on all sides. High electrical winds make it a true "dead spot." But WHB got through.

FRENCH SCIENTISTS INVESTIGATE STATIC

NEW SYSTEM DEvised IS PROVING SUCCESSFUL

Permits Two-Way Communication with
One Aerial; Static and Other Noises
Eliminated Automatically

PARIS.—The "static bugaboo" which has bothered Radio operators and listeners for all the long years that Radio telegraphy and telephony have been in use, is now causing much discussion in France. The French scientists, slow to take serious offense at such a bothersome item—more apt to shrug expressive shoulders and struggle along—have at last turned their full attention to the solution of the puzzle. They have developed several interesting ideas, if not actually reaching a solution.

The study of atmospheric disturbances by one entire branch of the governmental meteorological service is one step that has been taken toward eliminating static. This study is being made at considerable cost by Captain R. Bureau, of Paris, whose discoveries and theories have already been discussed before the French Academy of Sciences.

Second on the list of French static investigators—and even more important if his claims be true—is an engineer of the official Posts and Telegraph service, M. Verdan of Strassbourg. He maintains that he has discovered a way of eliminating all parasites from Radio telegraphic communications.

Uses Special System

Only a brief description of his apparatus is obtainable as yet. It suggests in some way the system of John Hays Hammond for secret communication. M. Verdan claims that by a special system of predetermined tangling and untangling of the signals, all impulses not meant for the set receiving the message will be eliminated automatically. Static will drop out just as effectively as will an interfering, uncoded message.

The receiving apparatus is applied with a printing machine somewhat like the Creed or Wheatstone types of automatic receivers. This apparatus is so connected with the aerial that it actually rejects any extraneous signals, either from other stations or from natural causes, which come through the aerial to it. Another big advantage of this new system, says M. Verdan, is that two-way work can be handled without having to separate the transmitting and receiving aerials. Simultaneous messages flash out and in without any interference, all sorting being done by the automatic apparatus.

Tests Prove Successful

Many tests have been made with success. Engineers claim a dependable all year round transmission method for Radio telegraphy and possibly, later on, for telephony as well.

It is expected, also, that the method will be useful in the transmission of photographs by Radio. The sunner static has virtually stopped the experiments of M. Belin on such Radio photograph work and it seems probable that this procedure will never work successfully until static interference is successfully eliminated.

WHK Will Increase Power; Operate as Toll Station

CLEVELAND.—WHK, Hotel Winton here; now employing but 100 watts, is rumored to be planning the installation of a 500-watt transmitter. J. N. Thorburn, engineer for Station WJAX, Union Trust company, will be engineer in charge of the new Hotel Winton outfit.

While officials at the Winton have made no statement, it is common talk that the new equipment will be operated as a toll station for profit.

Radio compasses, or direction finders, have been installed on the Leviathan and S. S. President McKinley, of the Shipping Board, eight ships of the Admiral Line, nine of the Matson Navigation company, and four of the Standard Oil company.

FAVORITE SCREEN STAR ON AIR



The young lady shown above is none other than Norma Talmadge, noted screen star, shown on the eve of sending out her first Radio message to American Radiophans from Station KGO, San Francisco. She is one of the few actresses who entertain audiences, but never see them. This presupposes a desire on the screen favorite's part to take a whirl at the spoken drama, which she is rumored to be considering. Radio, she claims, brings the star nearer to the public than the silver sheet. Whatever she decides, however, there will always be a warm spot in her heart for the Radiophans, and the Radio fraternity in general.

THE ANTENNA BROTHERS

Spir L. and Lew P.

Bovine Interference



SCIENCE BEGINS TO RADIOCAST TALKS

SMITHSONIAN INSTITUTION GOING ON AIR WEEKLY

Carrying Out It's Motto: "For the Increase and Diffusion of Knowledge Among Men"

WASHINGTON.—In carrying out its motto: "For the Increase and Diffusion of Knowledge Among Men," the staid and conservative Smithsonian Institution in this city has turned to Radiocasting as the most efficient means of disseminating knowledge.

In the latter part of September the institution will undertake a definite program of weekly scientific talks over the Radio from Station WHC, covering practically every branch of science, but so spoken as to appeal to lay listeners as well as those better informed. The program is under the direction of Dr. Austin H. Clark of the National museum, who has also secured the co-operation of the Carnegie institution, and several scientific bureaus of the government.

The first Radioeast by a member of the Smithsonian staff was that of Dr. Charles G. Abbot, Director of the Astrophysical observatory, who spoke last November on the heat of the sun's rays and his experiments with a solar cooker. The initial talk was so successful that in the spring other savants who could discuss natural history in a popular style, went on the air. Among the Radio talkers were Dr. Clark, who spoke on "Giants in the Animal World," Superintendent Hollister of the Zoological park who told of keeping and feeding wild animals, and Dr. Merrill, who spoke on shooting stars.

One unique stunt was the Radiocasting of real Indian music rendered by natives, to which the Smithsonian officials themselves listened on a radio set installed in the main building. Radiophans bothered by static heard a talk of great interest recently, when Dr. Mauchly of the Carnegie institution spoke on "Atmospheric Electricity."

Although Smithson, the founder of the institution, probably never thought of transmitting speech either with or without wires, it was recently learned that during one of his lectures, Joseph Henry, first secretary of the Smithsonian, said he regarded even the best copper wire as an impediment in the transmission of electric currents. He admittedly did not

Cook Requests Music But Radio Ruins Her

So Fond of Concerts She Forgets Her Cooking

PARIS.—An amusing human touch comes in a complaint from a retired Colonel of the French Army who likes to eat well, but lives in the country where good cooks are hard to keep. He had found at last an especially fine cook, but was dismayed to hear her begin complaining because she had no amusements in that lonely district, no movies, no music, nothing at all.

The Colonel, being in a serious situation, thought fast. He got a Radio receiving set, took it to his house, studied it over and installed it himself in the kitchen. All was serene once more after he had taught his domestic jewel how to operate the dials.

But now the cook is becoming a DX hound, and is so fond of the concerts that the poor colonel is forced to put up with burnt soup, overdone meat, and desserts forgotten in the making. He is still trying to decide which must go—the Radio or the cook.

TALKS TO ENGLAND

(Continued from page 1)

1,000 watts is the limit established by the department of commerce.

International Exchange Programs?

David Sarnoff, president of the Radio Corporation of America, has recently gone to Paris and London, with a view, it is reported, of arranging international exchange programs on high power, short waves for relay Radiocasting. In case the plan is carried through, American and Canadian Radiophans may expect this winter to hear local or nearby stations repeat Paris and London programs, while French and English listeners will hear local Radiocasts of American programs.

London and Manchester, it will be remembered, did some relay and Radiocasting last year of KDKA by picking up the short wave and relaying on their own power.

know how to dispense with the electrical communication, but thought that the men in his audience would live to see wireless telegraphy. This was seventy-five years ago, and today the institution he headed is Radiocasting its information to the country by Radio telephony.



The GREBE CLARIFIER



THE first practical, workable solution of the problem of radiation from regenerative receivers. Unlike the "wave-trap" it increases signal intensity.



\$30

- Increases Selectivity
 - Increases Signal Intensity
 - Improves Quality
 - Prevents Radiation
- And—
- Is Easily Connected

Ask your dealer or write for literature

A. H. GREBE & CO.

Richmond Hill, N. Y.

Western Branch—451 East 3rd St., Los Angeles, Cal.

Federal
Standard RADIO Products

THE Federal iron-clad performance guarantee does more than protect you from loss or disappointment when building your pet hook-up. It is a pledge of perfection which a manufacturer would not dare to give unless he had Federal's background of over a quarter-century experience in radio and kindred fields.

There are over 130 standard radio parts bearing the Federal iron-clad performance guarantee.

FEDERAL TELEPHONE & TELEGRAPH CO.
BUFFALO, N. Y.

Boston New York Philadelphia Pittsburgh Chicago
San Francisco Bridgeburg, Canada

 Filament Rheostat

 No. 95 Vario-Coupler

 No. 65 Audio Transformer

 Variable Condenser

 Bristol Senior Audiophone Loud Speaker

Simply a matter of taste

Some persons are satisfied if their Loud Speaker will produce big volume. The more discriminating, however, want their radio reception to come from the Loud Speaker with all the refinements of the original broadcasting.

It is for these more refined in taste that Bristol Audiophone is particularly suited. Here quality has not been sacrificed to obtain volume, but the two have been combined in pleasing proportions.

The Audiophone is ready to use—no auxiliary batteries required to operate. There are three models to select from, including Senior \$30.00, Junior \$22.50 and Baby \$12.50.

If sufficient amplification is not available in your set to operate a Loud Speaker, a convenient unit is provided in the Bristol One-Stage Power Amplifier. When used with Loud Speakers of the better class and particularly with Bristol Audiophone, music and speech are reproduced without any distortion that the ear can detect. Any desired amplification can be had by connecting several Bristol One-Stage Power Amplifiers together.

Price \$25.00

Ask for Bulletins Nos. 3011 and AY-3017

Made and Sold by

THE BRISTOL COMPANY

Waterbury Connecticut

 Bristol Baby Audiophone Loud Speaker



"DREAM DADDY" AND HIS COMPOSER AID

SPEEDS UP CONCERT USING TWO STUDIOS

SPECIAL CONTROL ROOM IS PLACED BETWEEN THEM

Assistant Director Places Artists So That No Time Is Lost, Making Program Continuous

BOSTON.—In order to facilitate speed in Radiocasting, Station WNAC, located in this city, has evolved the novel idea of using two separate studios with a special control room between them. In this manner, very little time is lost, and the Radiophans are well pleased as the program is practically continuous.

The director of the station announces the artist or artists from the control room, and as soon as the announcement is made throws open the microphone in the studio notifying the artist first by buzzer, and then by light. The assistant director moves from studio to studio placing the artists in their proper positions and there is not a second's wait between numbers. In this way, programs that would require several hours are put on the air in half the time.

One studio is about twice the size of the other and accommodates a full band, orchestra or chorus. The room is in rose and gray, beautifully furnished and draped in gray, rose shaded floor lamps, a concert grand and a talking machine complete the furnishing. Adjoining this, with double doors of glass is the smaller room in blue and silver, a grand piano, lamps and furniture make up this room. Double glass doors lead from the reception room and each door has a ruby light which glows when the microphone is open, warning anyone outside not to enter.

NEW STATION FOR BOSTON; LATEST

Code-Call WEEI Assigned; 500-Watt; Will Open Early in September

BOSTON.—WEEI, the new 500-watt Radiocast station of the Edison Electric Illuminating company, will open here with a bang early in September, taking the place of WTAT, the Edison company's present 100-watt outfit. WEEI will Radiocast on a wave length of 303 meters. The last three letters of the code-call stand for Edison Electric Illuminating (company). Two Boston Radio editors with C. R. (Bob) Emery, formerly director of WGI, will comprise the Radiocasting management of the new station. All programs will be under the direction of Mr. Emery.

Miss Marjorie Drew, in charge of the clerical program work at WGI, will be the senior clerk at WEEI, while E. Lewis Dunham, who has assisted Mr. Emery at Amrad, will work in a like capacity in the new station.

C. V. Purcell will head the technical end of the operating staff of the station. His headquarters will be in the operating shack, now being constructed on the roof of the Edison building. The studio, which is rapidly nearing completion, is on the fourth floor of the building and will be one of the most efficient and modern in existence.

Prize-Winning Graduates to Radiocast Performance

PARIS.—The reward of this year's four prize-winning graduates of the famous Paris Conservatory of Music was to be allowed to give their first public performance after leaving the conservatory before the microphone of the Petit Parisien station. Many letters of commendation, both for the excellence of the music and the good spirit of the performance have been received at the offices of the newspaper.

TELL ARTIST EDITOR OF YOUR FAVORITES

DO YOU have a favorite Radiocast artist whose picture has not appeared in Radio Digest? If so tell the Artist Photo editor about it. Write him a little note mentioning the artist's name and station and he will attempt to give you what you want. The photographs, however, will be restricted to those artists for whom there are a number of requests. Space limitations demand the latter provision. Just write your note to the Artist Photo editor, care of Radio Digest, Chicago.



The smiling face on the left belongs to Harry B. Ehrhart of WDAE, known as H. B. E. when he announces and tells the bedtime story. Mr. Ehrhart has a song written about him, and there is hardly a night that someone doesn't hear the strains of "Dream Daddy." On the right is Carl Zoehrs, one of WDAE's entertainers and co-composer of the "Dream Daddy" song.

Station WLW Revives Radio Plays; Comedy Is First

CINCINNATI.—Radio plays, or Radarios, as they are known at Station WLW, located in this city, where they were created a long time ago, have been revived. The first of the series was Moliere's famous play, "Business Man Turned Gentleman," and it utilized the modern jazz band instead of the orchestra of the days of Moliere.

The Radario adaption of Moliere's lengthy comedy was performed in but twenty minutes' playing time, during the action of which the listener follows the plot with the auditory sense and his imagination instead of having the actual stage setting and player-business to follow the eye.

In the revival of this successful Radario, the leading character was Senator Schultz.

AMATEURS GIVEN TRYOUT AT WNYC

All Sizes and Types Appear at Studio to Perform Before Microphone

NEW YORK.—Amateurs performed recently for Herman Neuman, music director at WNYC, municipal Radiocasting station in the Municipal building.

The real find of the afternoon was Helen Bourne, a young Baltimore girl who has come to this city in the hope of getting an engagement in light opera. Mr. Neuman declared it was a treat to have a voice of quality, splendid diction, poise and musicianship appear out of the blue. The youngest novice was a three-foot, 11-year-old urchin, who wanted to be "Carried 'Way Down South." He had a voice six times as strong as himself. Then came Helen Fitzgerald, 13, who sang about Mother Machree.

You never can tell from their looks what the artists will turn out to be. A man came in who gave the effect of a bookkeeper in need of a haircut, but he sang seasons like a Viking. Then there was the stubby Italian with two-toned shoes who worked in a boiler room, but desired to sing opera arias.

WCAE BOASTS OF NEW PERFORMER

Although Never Mentioned, He Is On Most of the Programs Presented

PITTSBURGH.—"Pete" WCAE, Kaufmann and Baer's, assistant to the assistant announcer's assistant, may not be known to Radiophans by his official title, but regardless, his charming obligato may be heard in the background of most WCAE concert programs.

Who is Pete? Why he's a little canary. Found almost dying in the lower altitudes of Moore's Cafeteria, Pete was brought to the roof top studio on the Kaufmann and Baer building.

When you find a better Transformer it will bear the name

THORDARSON

- 2-1 Ratio \$5.00
- 3 1/2-1 Ratio \$4.00
- 6-1 Ratio \$4.50

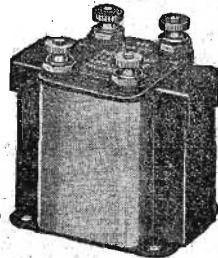

The mirror of the Broadcasting Studio

SUPER TRANSFORMER—2 to 1 Ratio (audio frequency)

The Thordarson 2 to 1 ratio amplifying transformer is indeed the mirror of the broadcasting studio. It seemingly brings the artists direct to your home. Install a pair—it will take you but a few moments—and you will marvel at the richness of the musical qualities obtained.

THORDARSON ELECTRIC MFG. CO.

500 W. HURON STREET

CHICAGO, ILL.



ABOLISH CLOTH FOR WOOD SLAT DRAPES

FOR BETTER TRANSMISSION EFFECTS WWJ CLAIMS

Station Engineer at Request of Owners Will Divulge-Plan to All Interested Radiocasters

DETROIT—Venetian blinds of bare wooden slats, instead of the usual heavy padding and drapes of Monk's cloth, now adorn the walls of the beautiful main studio of WWJ, the Detroit News. These slats, arranged like shutters, are adjustable to any angle.

Much better transmission effects are possible by this unique arrangement, according to Edwin L. Tyson, announcer-director of WWJ. The adjustable feature permits sounds to be deflected toward the ceiling or reflected directly from whence they come. Thus it is possible to have the same results as otherwise are attained only by having different sized studios for various instrumental or vocal arrangements.

The much noticed "dead" feeling, apparent in so many studios, is entirely lacking from WWJ since the innovation in wall hangings has been installed.

Engineer Campbell, of Radioeast Station WWJ, is inventor of the venetian blind scheme. While originally planning to patent the invention, Mr. Campbell, at the request of the Detroit News, will divulge the plan to all interested Radiocasters.

Boy Scouts Organize New Branch; Fixing Radio Sets

DETROIT—The boy scouts at Kalamazoo recently have established a Radio trouble department at scout headquarters in that city. Working in connection with Emerson V. Smith, a Radio expert, the scouts plan to locate and correct all Radio trouble that may arise to upset fans. Owners of sets who have experienced difficulty have been invited to bring their trouble to the scout headquarters. Interest in Radio does not seem to have sagged much during the present summer months. It is developing more rapidly than ever and the coming fall and winter will witness more enthusiasm for this pastime than ever before. This is the general opinion of Radio experts who have made investigations throughout the state during the last week or so.

Reduces Weight Via Radio; Claims Fan

Radio Operating All Night Wakes Up Sleepers

Announcement that the WOR morning gym class under the direction of Arthur E. Bagley is to be suspended until the early part of September brought forth hundreds of letters of regret from the Radio public.

One letter from a Radio listener who signs herself Mrs. Dunne, struck a humorous note in writing of the early morning Radiocasting. It appears that the family retired for the night and failed to turn off the Radio receiving set.

Early next morning Mrs. Dunne was startled to hear a man's voice in an adjoining room counting and recounting in muffled tones. The thoroughly frightened housewife jumped to the conclusion that a burglar was sorting over the family silverware preparatory to carting it off. She awakened her husband with the startling news and together they crept to the dining room, whence the sounds appeared to come. As they neared the dining room their fears were set at rest as the voice of Mr. Bagley boomed forth through the loud speaker—"One, two, three, four; now bend over completely and place the palm of each hand on the floor."

Mrs. Dunne recommends this Radio course for anyone desiring to lose weight.

Radio Show Will Have Big Contest for Set Builders

CHICAGO—Opening about the middle of November, a Radio show will be held in the coliseum in this city. Among the novelties to be introduced at this show is one for the builders of Radio sets.

There will be two classes of builders listed; one for the pupils of the schools in the states of Illinois, Indiana, Michigan and Wisconsin, the other for anyone who does not come under the upper class. This includes everybody who has built a set.

For entry blanks for this contest, write to Contest Department, Chicago Radio Show, 127 North Dearborn street, Chicago, Illinois, and they will be mailed to you. Workmanship, appearance, volume, distance, selectivity and tone will count in making the awards.

Considerable interest in Radio was shown at the recent spring fair at Leipzig, Germany, when eighty manufacturers exhibited goods.

Philip Latin With WQJ CHICAGO.—Another member has been added to the staff of the Calumet-Rainbow station, WQJ, located here. He will be on

the operating staff of which Robert J. Engler is head. Philip Latin is his name, and he was formerly attached to KTW, previous to which he was an operator on the S. S. Olympic.

Thrills from Radio

No. 25 of a Series Featuring Experiences of "ALL-AMERICAN" Users

What We're Getting on One Stage With All-Americans

By Messrs. Ireland, Collins and Penland

"I have been using a 10 to 1 All-American, Collins of Cleveland, Ohio. With a 10 to 1 All-American," writes Mr. Harold Penland of Weatherford, Texas. "I get Los Angeles, San Francisco, Oakland, Portland, Sehome, Tacoma, Springfield, Calgary and Vancouver nightly—the last one 1,700 miles away. Have heard 48 stations in one night."

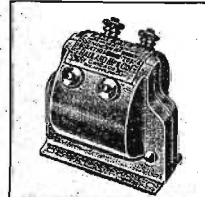

All-American Audio Frequency Transformers come in three ratios: the 2 to 1 at \$4.50, the 5 to 1 and 10 to 1 at \$4.75. There are no better instruments on the market at any price.

SEND FOR THE RADIO KEY BOOK Just out! Tells how to hear farther and better; all the most workable circuits clearly diagrammed; full of practical suggestions. Send 10c, coin or stamps.

"I received KFDG and WSB with Brandes Table Talker on one stage of amplification using one All-American transformer. I am proud to say," responds Mr. William

All the better dealers sell the "ALL-AMERICAN" **RAULAND MFG. CO., 2640 Coyne St., CHICAGO** PIONEERS IN THE INDUSTRY

Audio and Radio Frequency; Power Amplifying (input and output)



Over three-quarter million in use. Standard on the better sets

ALL-AMERICAN

AMPLIFYING TRANSFORMERS

Largest Selling Transformers in the World

Perfect!

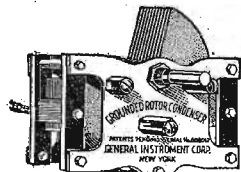

THE LOW LOSS GENERAL INSTRUMENT CORPORATION GROUNDED ROTOR CONDENSER

LABORATORIES USE IT Because actual tests have proved that dielectric losses have been practically eliminated. This makes it possible for your receiving set to surprise you with a new power.

RECOMMENDED BY A RADIO PROFESSOR A Professor of Radio Engineering in instructing his pupils said that to attain results such as no other variable condenser will produce you must use the Low Loss General Instrument Grounded Rotor Condenser.

REPLACE YOUR OLD CONDENSER If you are really anxious to "hear the difference" to get greater selectivity, more distance and a remarkable increase in volume, replace your old condenser with the NEW LOW LOSS GENERAL INSTRUMENT CORPORATION GROUNDED ROTOR CONDENSER. You'll hear the difference.

Type	Minimum	Maximum	Price
Type 48X 11 Plate	5 MMFD.	.00025 MFD.	\$4.50
Type 46A 13 Plate	6 MMFD.	.0003 MFD.	4.50
Type 46D 21 Plate	9 MMFD.	.0005 MFD.	5.00
Type 46F 43 Plate	15 MMFD.	.001 MFD.	5.50

AT YOUR DEALER

Otherwise send purchase price direct to us and you will be supplied.

GENERAL INSTRUMENT CORP.

423 Broome Street
NEW YORK CITY



TYPE JR-65



MARVELOUS NEW Dietzen

ADJUSTABLE

LOUD SPEAKER

At the Price of an Ordinary Pair of Head Phones

COMPLETE With Specially Built Dietzen Adjustable Loud Speaker Unit Not a Head Set

DIETZEN GUARANTEE

Money back at any time within 10 days of purchase if dissatisfied.

Special Features:

- Absolute non-metallic sound.
- Permanent crystalized finish.
- No batteries necessary.
- Specially constructed adjustable unit with gold plated diaphragm.
- Unconditionally guaranteed for one year from date of purchase against mechanical defects of any kind.

FREE!

Dietzen Radio Log Book: Write for yours!

DEALERS! Write for details

IF YOUR DEALER CANNOT SUPPLY YOU, MAIL COUPON DIRECT

DIETZEN, INC.

71 Cortlandt St.

N. Y. C. New York

Makers of Precision Instruments Since 1889

DIETZEN, INC. 71 Cortlandt St., N. Y. C. New York
Gentlemen, please send me one of your Type 11 of DIETZEN Loud Speaker's Price \$5.00.
Name _____
Address _____
Pin \$5 bill or money order here

Neutralizing the Super-Regenerator Circuit

Part I—The Circuit Used and Description of Parts

By C. E. Butterfield.

AIDED by Prof. L. A. Hazeltine's excellent method of controlling Radio frequency amplification the writer presents herewith a circuit whereby super-regeneration and Radio frequency have been combined bringing about resulting increased volume on distant reception. Difficulties encountered in the control of oscillation, even with the use of neutralized Radio frequency, were only surmounted after several months of laboratory experiments and were met through the use of a combination of negative or reverse and capacitive feedback in the detector circuit, in connection with high impedance coil in the grid return circuit. No control was placed on the regeneration, as it maintains its balance over the entire Radiocast wave length range, for which the circuit was specifically designed.

The set, which might be termed a "neutralized super," has considerably more volume than the straight neutrodyne, is just as selective if not more so, and will function to a certain extent on an aerial alone. While two stages of audio frequency amplification are indicated in the accompanying diagram, local stations and some of the more powerful distant transmitters come in with volume sufficient to actuate a loud speaker without the last step. In fact on locals, when the five tubes are operating, the volume is great enough to fill a large hall and is more than necessary for home use.

The High Pitched Whistle

The ever present high pitched whistle of the super regenerative set has been eliminated, as far as audibility is concerned. It is carried to such a high pitch as to be entirely inaudible. In fact, when the constants of the circuit were changed to make the whistle audible a considerable decrease in volume resulted.

An analysis of the detector circuit will show it to be a combination of methods from several popular circuits so gathered to bring the desired action. Negative or reversed feedback is used in a fifty turn honeycomb coil fairly closely coupled to the detector input Radio frequency transformer and placed in a fixed position. Then there is the .006 mfd. fixed condenser, popularized by our old friend, E. T. Plewelling, in his single tube super. However, this condenser has slightly a different feedback.

In addition there appears the 1250 turn high impedance honeycomb coil from Major Armstrong's super regenerative circuit. It is found in the grid return circuit to aid the regulating the flow of the grid current. Some builders may discover that this coil can be left out and the circuit function just as satisfactorily, apparently. Such is the case on strong local signals, but its need is quickly demonstrated when a distant Radiocast is filtering in. As the set must handle both weak and strong signals, its need can easily be seen.

Selection of Grid Leak

Too much emphasis cannot be laid on the selection of a proper grid leak, as its faulty design or construction will result in failure of the successful operation of the circuit. A grid leak should be chosen which will have a range of from one-fourth to ten megohms, be noiseless and easy in its adjustment. If the proper instrument is built into the set, its adjustment will be a simple matter and it can remain untouched unless the detector tube is changed.

The same is true as to the neutralizing condensers. Those used in the ordinary neutrodyne will not give satisfaction. They should be of a type very similar to the tuning condenser, but of course built on a much smaller scale. Their maximum capacity should not be over .0005. In fact, too much stress cannot be laid on the choosing of the remainder of the apparatus. It should be of the best. The tuning condensers, of which there are three, as in the neutrodyne, preferably should be those providing a straight line adjustment and have a maximum capacity of .0004. The Radio frequency transformers must have a four to one ratio with air cores. Preferably those with secondary windings of the honeycomb type should be selected, as they permit the saving of space and the rearrangement of the transformer in the detector input circuit. From the secondary of this transformer three turns are removed, as the close relation of the feedback coil will throw-off the tuning adjustment slightly in relation to the other two condensers and will make it difficult to reach the lower wave lengths.

Tubes Used

While other hard tubes than the 201A or 301A might be used satisfactorily, the builder is advised to select, no other, unless he has a power tube which can be placed in the detector circuit permitting a higher plate voltage and more volume. However, this power tube is not a necessity; in the laboratory tests only 201A's were used. They gave all the volume de-

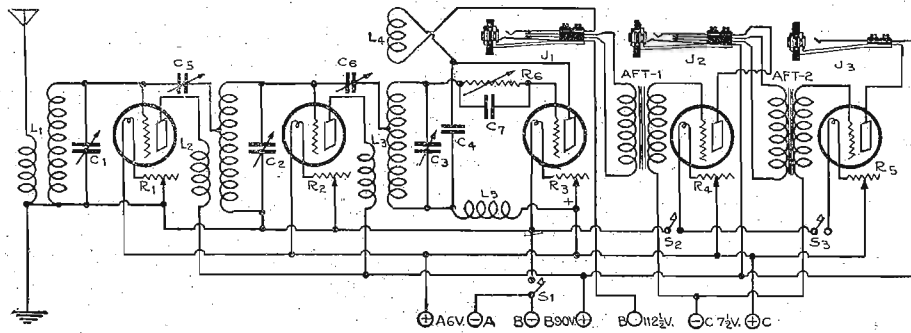

Parts values used in circuit. L1 and L2 are 4 to 1 air core transformers with secondary honeycomb windings; L3 is a 4 to 1 air core transformer with secondary honeycomb winding, with 3 turns removed from secondary; L4 is a 50 turn honeycomb coil; L5 is a 1250 turn honeycomb coil; C1, C2, C3 are .0004 variable condensers; C5 and C6 are .00005 midget variable condensers and S1, S2 and S3 are A battery switches.

sired, using 112½ volts on the detector tube and 90 volts on the Radio and audio amplifiers.

A C battery is shown in the diagram. While it is not absolutely necessary, the saving in the B battery voltage and resulting clarification of amplified signals is more than compensated for.

Note should be made of the fact that only one fixed condenser is contained. In

the preliminary tests more were used, but it was found that they were not needed, and in fact several of them brought about a decreased volume. To date no body capacity effects have been noted, and it is possible to touch the wiring at a ground potential and get no decrease or increase in volume.

List of Parts Required
L1, L2, L3, 4 to 1 air core Radio fre-

quency transformers, with secondaries of the honeycomb type.

L4, 50 turn unmounted honeycomb coil. L5, 1250 turn unmounted honeycomb coil.

C1, C2, C3, .0004 mfd. variable condensers.

C5, C6, .00005 mfd. variable condensers, midget base mounting type (neutralizing). (Continued on page 16)

They said it couldn't be done!

HERE

it is at



Clarity
Beauty
Volume
Distance
Selectivity

A 5-TUBE SET

built of the finest low loss material and in a beautiful genuine solid mahogany cabinet at only sixty dollars.

Ask your dealer for a free demonstration Complete literature gladly sent on request

FRESHMAN MASTERPIECE

A Tuned Radio Frequency Receiver

that will bring even the most distant stations to your home with surprising clarity and volume. So selective that you can pick up any station you want—night after night—at the same dial settings, and, what's more, it is the easiest set in the world to operate.

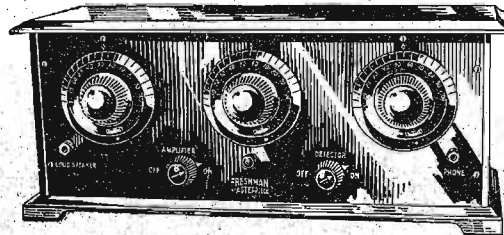

Chas. Freshman Co., Inc., 106 Seventh Ave., New York

AN EVENING AT HOME WITH THE LISTENER IN (SEE INSTRUCTIONS FOR USE BELOW)

Table with columns: Station and City, Met., Monday, Tuesday, Wednesday, Thursday, Friday, Saturday, Sunday. Lists various radio stations and their broadcast schedules.

Instructions for Use.—All the hours above are given in Central Standard Time. If your city uses Eastern Time, add one hour to each of the periods stated; if your city uses Mountain Time, subtract one hour; if your city uses Pacific Time, subtract two hours. In addition, your city uses daylight saving time, add one hour to this result. This table includes only the evening Radiocasts, and, on Sunday, the late afternoon program.

Want KOP to Locate Lost Children; Police to Help

DETROIT.—A Brown City, Mich., man has appealed to the Detroit police to resort to the Radio in an effort to locate his two daughters, 14 and 16 years old, whom he believes have been kidnapped by tourists. Rural folk are coming more and more to believe in the Radio and are resorting to it for many things other than amusement. This distracted father has great faith that the Radio will locate his two girls. Thousands of new receiving sets are

being installed in country homes all through Michigan. Even the remote lumber camps have them and it is almost impossible now to go anywhere in the state without being in immediate contact with the outside world. This was not so a year or more ago.

Only recently a Detroit judge, tired out and anxious to get as far away from civilization as possible, sought a remote camp in the northern part of the state. The very first afternoon as he was sitting quietly in the shade he suddenly came to consciousness when a voice from a loud speaker boomed out, "This is WWJ, the Detroit News."

Advertisement for DE Forest Radio. Features a large handwritten-style text: 'The Forest Radio is made by the man who invented broadcasting!' and 'DE FOREST RADIO TEL. & TEL. CO., Dept. R. D. 12, Jersey City, N. J.'

Free Proof

Never once has The Radio Shack failed to deliver the goods expected by our customers. Never once have we advertised any set or kit without FIRST making TESTS that we PUBLISH. Why not get yourself the profitable BENEFITS of this Real Honesty in radio dealings? Send now for the FREE "TEST PROOFS" of our unmatched Portable Ambassador and Neutrodyne described below. Write us, for your own good, today.

DE LUXE AMBASSADOR

Let The Radio Shack furnish you the PROOFS of hearing London, England on the synchronized De-Luxe 3-Tube Ambassador, the incomparable portable radio for the peak of ideal summer DX reception. Shipped all assembled ready to wire in an hour, just as picture shows. Send for the FREE "TEST PROOFS" and you will be truly amazed.

SET CONSISTS OF

- 1 DRILLED 7 x 10 Radion Mahogany Panel, engraved in Gold.
1 Genuine Ambassador Master 3-Circuit Litzendracht Tuning Coil.
1 Genuine Comco Bakelite-End Condenser.
1 Triplid Mounting Socket.
2 Premier Hegeloh Audio Transformers.
4 Brunswick Under-slung Foundation Brackets.
2 Brunswick Jacks with Gold-Plated F o n e s.
1 Freshman M i c a Grid Condenser.
1 Standard Glass-Enclosed Grid Leak.
2 30-Ohm Shackton Bakelite Rheostats.
2 Moulded Mahogany Dials grained to match panel.
5 Lengths Professional Round Bus-Bar.
1 Set of 7 Moulded Engraved Binding Posts completely mounted.
1 Special Blue Print for this circuit. Not an ordinary hook-up, but in clear picture form child can understand and make.
Assembled ready to wire, and in handsome box, complete.

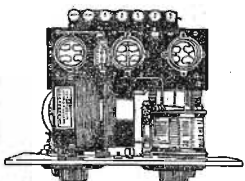

\$27.95 C.O.D.

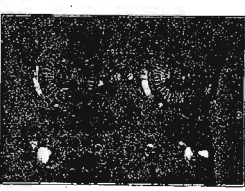

Special Suit Case Cabinet

Space for set, "A" and "B" Batteries and Antenna. Covered with fine automobile leather. Fabricoid, reinforced genuine leather corners and handle, special convenient doors. A truly elegant, high-class affair that you will delight to own. Additional—

Only \$27.95 C. O. D. Send no money.

ACCESSORIES

- Everything needed to operate after building is listed here—
3 Type 201-A Tasted Tubes\$11.70
1 60-Ampere Hour Storage Battery\$6.50
1 pr. 3000-ohm Head Phones and Cord\$3.75
1 Phone Plug, Double\$0.90
1 Antenna Equipment\$1.50

Complete outfit, \$35.50 (Parts Also Sold Separately)

SPLENDID CABINET

FREE

Order Building Kit and Accessory Outfit together, and we will send Fine Mahogany Finish Cabinet FREE.

The De-Luxe NEUTRODYNE

SET CONSISTS OF

- 1 Drilled Mahogany Panel, polished mahogany effect, engraved in gold.
1 Four-inch Mahogany Dials, gold engraved.
1 Plated Knobs.
1 Genuine Hazeltine Neutrodyne mounted on the Comco Bakelite-End Condensers. Positive-ly the only Neutrodyne Kit including them.
2 Hazeltine Neutrodyne.
2 Heavy Bakelite Sockets.
1 4-Ohm Rheostat with gold plated knob to match panel.
1 30-ohm Rheostat with gold plated knob to match panel.
2 Genuine Klipsch Completely Shielded Audio Transformers.
Baseboard.
20-inch Tuned Bus-bar.
1 60025 Freshman Grid Condenser.
1 Double Glass Grid Leak.
1 Set Engraved Binding Posts.
1 602 Micon Condenser.
1 1066 Micon Condenser.
Each set special blue print and instructions.
All packed in attractive box.

Let The Radio Shack furnish you with PUBLISHED PROOFS which PROVE our synchronized De-Luxe 5-Tube Neutrodyne superior to all others using neutrodyne circuits. Send for this TESTIMONY. See why we say that our genuine licensed Hazeltine Neutrodyne is the best of all Neutrodyne. This information is absolutely FREE.

\$34.49 C.O.D.



Complete Building Kit, \$34.49 C. O. D.

- OPERATING OUTFIT
5 Tested Tubes (Type 201A)\$19.50
2 45-Volt Extra Large Variable "B" Batteries for Neutrodyne 6.50
1 80-Ampere Hour Storage Battery, guaranteed 2 yrs. 11.25
1 pr. 3000-ohm Head Phones and Cord 3.75
1 Phone Plug, double90
1 Antenna Equipment 1.50
Complete Outfit, \$43.40, C.O.D. (Parts Also Sold Separately)
If you order Building Kit and Operating Outfit both together, we will include Fine Mahogany Finish CABINET FREE.

The RADIO-SHACK Send No Money. Largest Radio Dealers in America. 55 VESEY ST., NEW YORK CITY. Every Article Sold on WRITTEN Money Back Guarantee.

Monday, August 25

(Continued from page 11)

WNH, New York, N. Y. (Eastern, Daylight, 360), 2:15-3 p. m. Jimmy Clark and entertainers; 3:15-5 p. m. Arthur...

Tuesday, August 26

WTAS orchestra; 10-11. Alan Hooker, pianist; old-fashioned medley. Hill, Hirsch, Goran; Mary Jayne, Betty Holmes...

WHAS, Louisville, Ky. (Central, 400), 4-5 p. m., Albano theater orchestra; 7-30, Keith Kinnard and his Kentucky band...

Outside Loop Aerial

Owing to the fact that I had no space to put up a single line outside aerial I devised the outside loop as shown in the illustration.

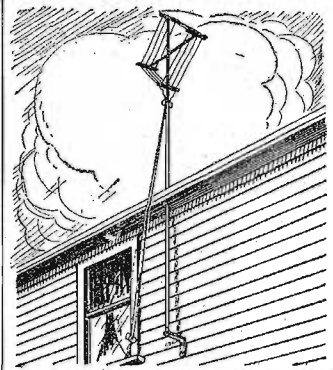

which is made of hard rubber. To hold the wire on the loop take each end is continued down a few inches to a lightning arrester.

As an added safety measure it is always a good idea, after you have put your set away for the summer, to connect the aerial and ground wires together.

Advertisement for Tower Scientific Headset, featuring 'A \$200,000.00 COMPANY STANDS SQUARELY BACK OF EVERY PHONE' and 'WORLD'S GREATEST HEADSET VALUE'.

Advertisement for Bakelite Insulation, featuring 'UNLIMITED GUARANTEE: A NEW WALNART SOCKET FREE FOR EVERY ONE THAT BREAKS OR FAILS' and 'WALNART SENSIBLE SOCKETS'.

Advertisement for Radiotron UV-199, featuring 'A Small Tube That's a Big Performer' and 'The new UV-199 is proving a mighty popular member of the Radiotron family'.

Advertisement for Coto Coil Co., featuring 'Stop the Leaks!' and 'Save all the energy in the antenna for your detector tube'.

30 Minute A-B-C Lessons for Radio Beginners

Chapter XXI—Choosing a Radio Outfit

By P. E. Edelman

IN THIS series of articles the story of Radio is told in so simple a manner that the uninitiated can follow theory and practice whether or not he knows anything about electricity or its application to Broadcasting and reception. The series consists of twenty-five chapters, of which the four next will be:

- Chapter XXII—Making Your Own Radio.
- Chapter XXIII—Fixing Up the Radio Set.
- Chapter XXIV—The Radiocast Listener's Brief History.
- Chapter XXV—Home Radio.

THE choice of Radio outfits are divided into two types for use with outside aerial and those operating equally well with indoor short aerial or loop. An outdoor aerial equipped set can sometimes be used with indoor wave pickup means but will usually have less satisfactory range. Some sets designed for use with outdoor aerial do not operate satisfactorily with indoor loop phantom, aerial or pick-up circuit.

The aerial question is easily disposed of. Using an outside aerial, the best distance range can be had with less equipment, but subject to more interfering disturbances, particularly during the summer months. Some places an aerial is out of the question. The landlord will not allow it. If you do put up an aerial or have one installed, be sure that it is done substantially and protected with lightning arrester as required by underwriters.

Buying a Set, or Making One

The next thing to decide is whether you will purchase a complete manufactured outfit or make it from materials or parts. Unless you have some experience or can hire it, a properly selected manufactured set is far more likely to give satisfaction. The difference in cost of assembled parts and parts suitable for assembly is not so wide as was formerly the case, due to increased quantities manufactured. The average beginner can favor the assembled set, even if some neighbor with experience makes it, rather than attempt to build the first outfit. For some, however, the pleasure of making a set and seeing it operate is worth while, and to date it is a fact that a majority of sets in use are wholly or largely home assembled.

Where do all the Radio outfits go? Some reach the "As Is" or second use market. The beginner can sometimes get good operating sets discarded by others but should at least see the set working satisfactorily prior to making the purchase.

Probably the crystal set costing as little as \$5 complete with equipment can be favored for earphone reception within five miles of a local Radiocast station. If children smash it, not over \$5 is involved. There are no batteries or tubes to buy. The best form to choose is one using a permanent or semi-fixed type of crystal

detector, as the adjustable variety are difficult to keep in sensitive condition. A clear reproduction can be had from a crystal set.

One Tube Set

From \$16 to \$40, there are available completely equipped, one tube outfits, and dry cell operation is preferable. A tube such as WD-12 or UV-199 can be used. The non-regenerative form may be clearer but most outfits of this kind use considerable regeneration. The sets using feedback and directly coupled to an aerial are the kind which can radiate interference to neighbors. For city use, the non-regenerative one tube set, or the one tube set operated on the reflex principle without Radio feedback is to be preferred.

Despite all that may be said, numbers of one tube single circuit sets using regeneration will continue in use until such time as a two tube outfit can be had for the same result at about the same cost. i. e. until tubes are cheaper. The beginner is certain to cause equal complaints on neighboring sets if the close coupled single circuit regenerative type of one tube machine is used. The two circuit tuned, one tube regenerative set, is preferable. The beginner will usually not tackle a three circuit tuner at first. Too many tuning dials mean that many more chances to miss a Radiocast program.

In order of choice, first a one-tube set for local use, non-regenerative; second, the same reflexed; third, distance two circuit, loose coupled, preferably with additional one stage Radio amplifier.

Two Tube Sets

Two tube outfits of the reflex type will afford best results, as in simple form, one stage Radio, one stage audio, and detector can be obtained from two tubes. Using crystal detector two stages of Radio and two stages of audio can be had from two tubes. Two tubes permit use of one stage Radio and a regenerative feedback tube detector outfit for distant program pick-up with earphones.

The usual form of three tube outfit is: Detector plus two stage audio amplifier, and this will work nicely with outdoor aerial to operate a loud speaker. Three tubes can be arranged, reflex fashion, as two Radio and two audio with detector or two Radio and three audio with crystal detector for long distance reception, employing outside aerial, or intermediate distance with indoor aerial, both permitting loud speaker volume. The best use of three tubes is made in reflex combinations. Two or three tube combinations employing Radio frequency amplification permit satisfactory operation with indoor loop.

Four tubes can afford one stage tuned Radio, detector and two audio, for aerial operation, or use with indoor aerial. Reflex combinations of four tubes permit long range loop reception with loud speaker output. Six tube sets may be found with three Radio, detector tube, and

two audio. Some super-heterodyne outfits use six tubes, up to eight or ten tubes.

The Best Set Money Can Buy

The best set money can buy is also a matter of choice and presumably an unlimited spender would not be satisfied with manufactured cabinets any of the hot polloi might purchase on time payments. Sums may be spent on elaborate cabinets or hand made hand carved furniture boxes. A very elaborate set might be made to order to fit desire or whim. But it is doubtful if after an expenditure exceeding \$500 to \$1000 for one installation, there is any further inducement to get something better for further price increase. Such a set will usually be fitted with special switches and controls for distant reception, volume control, etc., and ordinarily not employ an outside aerial.

In choosing a set, don't get one requiring a storage battery unless you get a charging outfit to go with it. Or if you are depending on dry cell operation, don't take a set which requires too much a battery, as run down cells will be a continual nuisance.

Portable Sets

A portable set is desirable, as it can be moved about without disconnecting the wiring to the batteries. A portable set can be installed as a permanent one, but

not vice versa. A set which can be carried from place to place is useful in summer. Dry cell operation is preferable.

The first set should preferably be one which is moderate in cost and easy to operate. Avoid outfits using too many adjusting controls unless you are willing to learn to use them, otherwise the results will be disappointing.

Tubes to Use

Manufacturers usually recommend the type of tube to use for best possible results. If you intend to use dry cell tubes, ascertain if the set is constructed with correct size rheostats therefor. Tubes designated as detectors or those of the soft variety usually are preferably used for detection though results can also be had from hard tubes. Reflex outfits usually require tubes with large amplifying output. The average listener will choose a tube with standard base, as renewals can be had anywhere. In choosing tubes, it is to your advantage to have each tube tested in a receiving set before purchase, as some makes of tubes vary widely.

Markings of Doubtful Sets
Outfits to notice, of doubtful class, will have dials which do not run true, wiring (Continued on page 16)

\$2.00
At All
Dealers



Use the Bradlexohm THE PERFECT RESISTOR.

When you are looking for a resistor for your radio circuit, ask for the Bradlexohm. It is made in three sizes for your convenience.

- Bradlexohm 10—10,000 to 100,000 ohms
- 25—25,000 to 250,000 "
- 50—50,000 to 500,000 "

They are not affected by temperature or moisture, and can be varied over a wide range for best results. Ask your dealer about them today.

ALLEN-BRADLEY CO.
290 Greenfield Ave. Milwaukee, Wis.

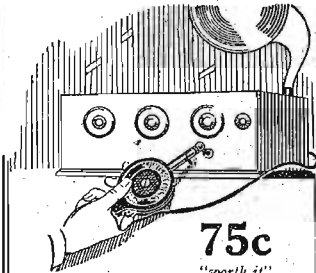

Poly Plug

Eliminates every inconvenience so annoying in the operation of the unsatisfactory screw type plug.

There is no necessity to take Poly Plug apart, no screws to tighten, and what's even more important, positive contact is always maintained.



A wonderful feature of the Poly Plug is the tension slot, allowing the phone cord to be slipped on and jarred without disturbing the contact.

At your dealers or sent postpaid on receipt of purchase price.

POLYMET MFG. CORP.
70-74 Lafayette Street
New York City

WORLD BATTERY COMPANY
Makers of the famous World Radio "A" Storage Battery.
1219 S. Wabash Ave., Dept. 76, Chicago, Ill.
SAVE \$2.00 BY ORDERING NOW!

SEND NO MONEY
Just state number of batteries wanted and you will ship dry cell or storage battery. O.K. O.K. O.K. batteries to return (if you prefer) for \$3.00. Expressman examining batteries. 5 percent discount for cash in full with order. Send four orders NOW! You save 50%!

WORLD BATTERY COMPANY
Makers of the famous World Radio "A" Storage Battery.
1219 S. Wabash Ave., Dept. 76, Chicago, Ill.
SAVE \$2.00 BY ORDERING NOW!

FREE
To Each Purchaser of a World Battery

24-Volt "B" Storage Battery positively given FREE with each purchase of a WORLD "A" Storage Battery. The WORLD Battery is famous for its guaranteed quality and service. Backed by years of successful manufacture and thousands of satisfied users. You save 50%!

Prices That Save and Satisfy

Auto Batteries	Radio Batteries
6-Volt, 11 Plate \$12.25	6-Volt, 120 Amps. 12.50
6-Volt, 13 Plate 14.25	6-Volt, 120 Amps. 12.50
12-Volt, 7 Plate 17.00	6-Volt, 140 Amps. 16.00

Shipment Express C. O. D. subject to examination.
5 per cent discount for cash in full with order.

2-Vr. Guarantee Bond in Writing
With Each World Storage Battery

Prove satisfactory world performance. Mail this ad with your name and address—we will ship battery day order to receive and give you choice of any of our batteries. Satisfaction guaranteed. Write TODAY.

WORLD BATTERY COMPANY
60 E. Roosevelt Road, Dept. L, CHICAGO, ILL.

This FREE "B" Storage Battery takes the place of dry cell to be sold retail for \$5.00. It is the only battery of its kind and is the only battery of its kind that is guaranteed to last for years. Take advantage of this offer. We will send FREE a copy of our new book "The World Battery" to you if you will send us your name and address to specify which is wanted.

GIVEN FREE
To introduce this superior World Battery to the Public

WATCH Premier This Year

It will pay you to keep your eye on PREMIER this season. There will be some new surprises that will make you "Sit up and take notice." PREMIER PARTS will be very much heard from and talked about so keep "tuned in." Send for latest Bulletin No. 94!

Ask your dealer

Premier Electric Company
3810 Ravenswood Ave. CHICAGO

\$1.79 for a Crystal Set

EQUIPPED WITH Genuine Miller-B-Metal SEMI-FIXED CRYSTAL

A rare opportunity to own a real crystal set. Miller-B-Metal's \$1.00 Loud Talking Semi-Fixed Crystal is in this set. The price for the complete outfit is only \$1.79—a special offer. Set reaches up to 500 meters with excellent volume.

You will like this New Miller-B-Metal Crystal. A rotating bakelite disc gives you contact where you choose and the catwhisker stays where you put it. Guaranteed to satisfy you. Send money order or we will ship C. O. D.

Jobs—Dealers
Stock these sets now for they certainly are in demand. Miller-B-Metal Semi-Fixed Crystals continue to be popular in your localities. Write for details.

The A. H. Miller Radio Co.
1222 26th Street, Detroit, Mich.

Radio Digest

PROGRAMS
Illustrated

Published by the Radio Digest Publishing Company, Inc.
510 North Dearborn Street
Telephone: State 4372, 4373, 4374, 4375
Chicago, Illinois

E. C. BAYNE, Publisher
Evans E. Plummer, Managing Editor
Charles F. Smisor, Editor
Harry J. Marx, Technical Editor

Eastern Office, 611-12 Times Bldg., Times Sq., New York;
Telephone Bryant 4909, 10462

Member of the Audit Bureau of Circulations
58
PUBLISHED WEEKLY

SUBSCRIPTION RATES
Yearly in U. S. and Possessions and Canada, \$5.00
Foreign postage, \$1.00 additional. Single copies, 10 cents.

Vol. X Chicago, Saturday, August 23, 1924 No. 7

Direct to Consumer

Reasons Why Radio Is More Popular This Year

REPORTS from various sources throughout the country disprove the popular theory, based on facts arising out of last year's experience, that Radio sets would be deserted by their owners this summer, who take to field, mountain and sea shore at the call of the great out-of-doors. On the contrary, statistics thus far gathered clearly indicate a decided trend among Radio enthusiasts toward the use of the compact portable instrument, an offspring of the home receiver, which is taking its place at the camp, aboard the small boat and in many instances is considered an essential part of the traveling pack of the automobile tourist.

Several reasons have been advanced to explain this landslide of interest in the summer Radio. In the first place, there are more high-powered Radiocasting stations in operation this year than last. In fact, the entire country is so effectively blanketed with Radio that even the remotest corner of the land is adequately served by Radio programs. Secondly, fans looking forward to a running description of the athletic classics staged in the larger cities, are making preparations for receiving these popular Radiocasts. The Radiocasters are alert to the special interest in big league baseball returns and many have already set aside a specified time at which they will hurl this bit of information into the air.

With the portable super-heterodyne set the vacationist, wherever he may be, need but press a button, twist a knob and a vast store of information and entertainment is snatched from the skies in "direct-to-consumer" fashion.

About Censorship

Prominent Men Oppose Over-Regulation

IT IS quite probable that some regulation will be required for Radio. At first there was no regulation for automobiles, but now the uninitiated has to learn many rules governing the road, speed, right and left turns, red lights, and other things. You cannot always go just where you want and so it will be with Radio. Not all Radiocasters will use a station for the public benefit if there are no lines drawn. However, here is what one official in the Radio business has to say.

"Public interest should be the sole test for admission to this illimitable forum. No political, racial or color line should ever be drawn. To tax the public for Radio reception would be a reversion to the days of toll roads and bridges, to the days when schools were not free and libraries were not public.

"The danger of freedom of speech by Radio is not the danger that any one interest will ever be able to monopolize the air. The real danger is in censorship, in over-regulation. If the Radio industry is to give to the public the greatest possible regulation; if the air is to be kept free for the public good, public opinion must determine the fitness or unfitness of those who seek to appear at its bar."

We all have heard this kind of talk before. It would appear to any person that Radio needs little encouragement, for it is going pretty good and the words spoken come from a person that desires his company to gather in all the shekels it can while the business keeps up regardless of what is put on the air.

Sherman Anti-Trust Act

There Seems to Be an Agreement to Fixed Prices

IF YOU ask almost any of the millions of Radiophans in this country what they think of the fairness of business dealing among the large Radio concerns, you will undoubtedly receive a suggestion that there exists a condition contrary to the intent of the Sherman Anti-Trust Act. The Federal Trade Commission recently reported a charge of monopoly among some of the companies. Still more recently comes the news of an anticipated attack on these Radio equipment companies for alleged violation of the anti-trust laws. A few department officials indicated a belief that certain Radio concerns were guilty of an agreement as to fixed prices. This may, or may not, be the case in fact, but it would be hard to convince most of us of their rectitude.

RADIO INDIGEST

Crimes of Radio (No. 1,313)

By Simply Waddles

HARD luck you have had but perhaps you'll agree not quite so hard as this fellow McGee. McGee once decided that he'd like to hear this Radio music and so in good cheer he sent off (for far from the city he stayed) for a Radio crystal set of which 'twas said it would bring in very soon found. For listening in, except stray dot-and-dash, 'twas entirely as useful as a plate of cold hash.

But McGee, undiscouraged, decided to buy a tube set and waited impatient to try the contraption. But he felt like a rube, when it failed to respond without bats and a tube. Finally gleaming the point at stake, he saw he had made a decided mistake and for accessories sent off once more, although he was feeling a little bit sore.

The tube received was put in the socket, but oh, how forty-five volts did knock it! "A" bat, and "B" bat, meant naught to McGee but he was right there with the profanity.

We skip the long weeks and once again find McGee getting ready for the music this time.

WITH care his connections he this time makes fast but luck was out stirring the tempestuous blast and sent McGee scuttling to shelter his swine. In fact sent him out in the bare nick of time, for when he returned he found set tube and phone by lightning and blithering Hades was blown. Baffled McGee used just then. He grabbed up a pencil and in but a trice had ordered: "A complete set and to hang with the price."

It came along promptly and without delay. Can we speak without tears of that fateful day? How he struggled to get it to work and then found, that a stray piece of hay-wire his aerial did ground. Remast and antenna crashed down to the earth.

With axe raised on high McGee tackled that set. Transformers, coils, all, a single fate met. Nor stopped he till every last volt was kaffooy and the Radio looked like a dish of chop suey.

A Radio salesman at the door then did knock of Radio's charms to persuasively yalk. And McGee swinging smartly his lethal bright axe, murdered that salesman right there in his tracks.

"Aw! Hava Heart OM"

Oh My Gosh a Guessin
Do I Hissen right?
"Come up to ol' Chicago"
See you later an' invite.
"But leave the radio at home"
—"What's that you say?"
Who in Halleujah
Wants to go that way?"

CACTUS JACK.

Mrs. Partington Speaks Out

Dear Indi: Mizz Partington says these here super-tuned frequently radios, reflexed neutralized and degenerated, lobbbed or "straight-eight" sets, with all the rest of the dog-day inventions, aint nowhere near as bewildering as the current political hookups being offered for the "Dear People" to decide on, at the coming contest next November. The head of one of 'em, she hears, is no good because he "saws wood and says nothing" like a Sphinx, instead of being a rough rider like Paul Revere. His running mate won't hear do either, because he said "Hell and other euss-words, right out loud, at an inquisition in the sacred halls of Congress.

Another one was condemned for playing marbles with rich folks' boys in Wall Street, until he choosed a real "Dirty Farmer" boy for his chum. A third one started deliberating whether he would get more votes, to tag a Bolshevik or a Labor Union to be his Vice.

She says this latter aint no "Third Party" just "Independent. All nominees are required to be independent enough to hang onto the big salaries they draw regular for misrepresenting jobs. They gotta work hard and faithfully to denodck the election into the Senate, so that one Independent Senator can elect our next President, by hissself, and can tell the other twenty million voters where to get off at.

I Bet He's a Photographer!

Dear Indi: There is a funny fellow up in Canada that keeps saying "one moment please" and before he can say any more, the music always starts and I ain't never heard what he wanted to say.

IN. S. ULATION.

Having Already Got Wet

Dear Indi: The Snow Yawk Sun pulled this'n the other day. The late belted-chain, hearing her worser half, a scofflaww by-the-way, attempting to enter the house and fooling with the doorknob, sez, "What are you doing down there, Oswald?" To which the spifflicated hubby babbles, "Fshh! I'm trying to get Sch-h-enectady!"

SPIDER WEBB.

WANTED—A radio set that will radiate so bad it will melt the antenna. I wish to give some single circuit fans some of their own medicine. Communicate all suggestions thru this column.

WHBDAP.

They Never Cease

FREAK SETS



Condensed

By DIELECTRIC

Members of the A. R. R. L. have staged a number of tests in which it was the purpose to reach other amateurs in England. Gratified with results so far, they have arranged two ten-day periods, one this month and again in September, when attempts will be made to communicate with amateurs in Australia. Success should crown their efforts because many of our American amateurs have been heard in that country already.

There has been no settlement of the question as to what should be put on the air, although opinions have been expressed by both Radiocast directors and the listening public. It is assumed of course that the stations themselves wish to Radiocast such material as will meet with approbation by their audiences; in each case by a majority. If you do not give expression to your views regarding any subject matter proposed for Radiocast, then the "majority" known to the station may represent the less desirable element. Would you be willing to have your child tune in the proceedings in a trial of two loathful degenerates? One newspaper stoops rather low to even suggest that a notorious trial be brought to the attention of self-respecting men and women—not to mention the youth.

It is not so difficult to picture the process of Radiocasting music from the studio of any of the five hundred odd stations in the country, as it is to conceive of music carried by Radio waves from an open air concert with the attendant sounds from those present, police whistles, auto horns, etc. Listening to the concerts of the U. S. Marine band Radiocast from close to the Washington Monument, with the three or more thousands of people applauding each splendid rendition, it is not easy to picture the millions of folks doing as you are. Yet they are.

Whether the Russian Council of Commissars has in view the opportunity to increase its income, or to add to the pleasure of Russia's millions, Radio is steadily advancing in that upset country. The government is to undertake the manufacture of receiving sets not to exceed in price \$15, while at the same time giving free rein to the ambitious to construct their own sets. A moderate license fee is to be asked in either case. It is also hoped to reach the United States via Radiophone upon the completion of the Khodynka station, which is to have a capacity of 150 kilowatts.

At the time the Gimbel Brothers station WIP, in Philadelphia, opened its new studio on the steel pier at Atlantic City, the directors announced a feature of interest and novelty. The breaking of the waves of the Atlantic ocean upon the shore were to be heard by the heated residents of inland cities, affording twice daily a chance to work the imagination in respect to cooling the body. One day last month this station added a new feature to scientific research in carrying the speech of a diver (walking upon the bed of the sea) to countless listeners in, so that what he saw was instantly Radiocast to the world.

The Bureau of the Census is engaged in compiling a census of Radio sets and apparatus manufactured during the calendar year 1923. This is part of a general census on the electrical machinery and apparatus industry, though this particular survey applies only to apparatus manufactured and not to sets in use or the distribution of same. The specific products to be tabulated under Radio apparatus include receiving sets, tube and crystal, loud speakers, head phones, transmitting sets, transformers, rheostats, lightning arresters and miscellaneous parts.

Proper Operation of Regenerative Receivers

How to Avoid Annoying Your Neighbor

By A. K. Phillipi

THE Radiocasting of concerts, speeches, and many other interesting features by Radio has increased to such an extent that thousands of receiving sets have been installed in homes, clubs, and churches.

The opportunity afforded the public today to listen to good concerts and speeches by men prominent in all branches of science and industry without having to leave their own homes was, a few years ago, unthought of.

How many of you listening in are sure that your listening in is not preventing some other person from enjoying some Radio program? This is not to infer that you should lend them your receiving set, but that you, by the improper manipulation of your set, are causing a disturbance in the air that interferes with your neighbors proper reception of the program.

How many of you, never having driven an automobile, would go to a dealer and buy a car, get in, and drive away, without first being instructed in driving and handling a car? Such a person would be considered a public nuisance and would soon be arrested.

While the operation of a Radio set by a person not knowing just what he is doing with it will not endanger the lives or property of others, yet it can cause so much annoyance that it greatly mars the pleasure of others. The majority of people are good sports and play the game fairly to the best of their ability and people who do cause these disturbances are usually those who are unfamiliar with the operation of their receiving units.

Study Book of Instructions

When a receiving set of standard make is bought, an instruction book which tells how to operate the unit is generally included with the equipment, and a careful study of this book will give the operator a fair idea of what to do and how to do it, so as to get the best results as well as to cause the least interference possible while tuning in the desired station.

It is impossible for all of us to be electrical engineers or Radioticians. Neither can we all be automotive engineers or auto mechanics, yet thousands of people drive their own cars in such a way that they bother no one. These people are good sports.

Radio listeners are not all good sports, but the majority of them are and the reason they so often cause disturbances in the air is because in most cases, they are not aware that they do so. It is my purpose to point out some of the things to do and what not to do when tuning in, so as to prevent disturbances which can be heard by other listeners.

Tuning In

First of all, the Radio set should be of a good design. Secondly, it should be connected up properly. We now turn on the filaments of the tubes to their proper brilliancy. This varies with the different types of tube used. With the clicker or amplification dial or pointer turned to zero, we next move the tuning dial or dials slowly from left to right listening for signals. If no signal is heard, the clicker or amplification dial should be advanced slightly from the zero position on the dial, and again the tuner dials should be turned slowly over their range. Should a signal be heard but faintly, the tickler

should be advanced as far as possible without causing a hissing sound, which indicates that the tube has passed the point of greatest regeneration and is oscillating. These oscillations are just like another transmitting station sending out signals as they are heard by other receiving sets and are known as "birdies." The tickler should be turned back until the signal is cleared up or even a little past that point, for a too strong signal may cause the detector tube to break over and oscillate again.

The best way to make sure your detector tube is not disturbing others is to plot a tickler diagram. This is done as follows: after the tubes are lighted to the proper brilliancy, the tuner is placed at zero and the tickler is advanced until a click is heard. At this point the tube starts to oscillate. Then mark down the readings in two columns, one marked tickler and the other, tuner. Next the tuner is advanced one large division, and again the tickler is advanced until the click is heard, and these readings should be taken. This procedure is carried out over the entire tuner scale, and it can readily be seen that, with the use of this set of readings, one will be able to set the tickler or amplification pointer to a division just below the oscillating point.

Click of the Tube

Now it is possible that the click or breaking point of the tube may not be heard by merely turning the tickler. If so, the operator should tap the antenna post with his finger and, when the tube is not oscillating, he will hear only a signal click. As soon as the tube starts to oscillate, the operator will get a click when he touches the antenna post, and another click when he takes his finger from the post, or in other words a double click. Now it is not advisable to do this during the program period, but during the day when the chance of disturbing others is at a minimum.

The ideal regenerative receiver and antenna will have what is termed a flat tickler curve. By this we mean that it will be possible to put the tickler at a certain point and the tuner any place and be at maximum regeneration without causing oscillation. If the set has this characteristic, much less trouble tuning in stations without annoying others will be experienced.

The reception of signals at zero beat causes more interference than any other method of tuning and should be discouraged. The results obtained are not at all satisfactory unless one juggles the vernier or tickler dial. Each movement of either dial causes the detector tube to transmit weird signals and those in turn are heard by all local listeners. Again the varying strength of signals may cause the detector tube to flop from one side or the other and ruins the program not only of the people but of the person tuning the set as well. The crystal type of Radio receiver, as well as those having one or more stages of Radio

frequency amplification, causes no disturbance of this kind.

It is possible, with the co-operation of all Radio listeners, to clear the air of "birdies," or the "wail of lost souls," as they so aptly have been called, if each and every one of us will take precaution to see that our detector tubes are not oscillating. To do so demands that we all to the best of our ability observe the golden rule.

Radiocasting Without Using Carrier Wave

Radiocasting without the use of carrier waves, said to be one of the greatest revolutions in Radio since the discovery of Radiophony has been brought to light recently at Station WRM, the Radiocasting station of the University of Illinois, which is operated both as a transmitter of University events and as an experimental station for students and faculty members in the department of electrical engineering.

This new system of Radiocasting—suppression of the carrier waves—is at the present time used in long distance telephony over wires, but the carrier must be again supplied at the receiving end. With the new system the latter provision is unnecessary.

Tubes Use Less Power

In using this new system, the tubes consume about one-sixth of the power ordinarily used for this purpose. A little excitation however, is used on the oscillator to start it operating and take care of the lag in the tubes picking up the impulses. This excitation can be eliminated, but there will be a slight sputter. As yet, the developers of this system, Hugh A. Brown and Professor Kneipp of the physics department of the University, admit that this system is by no means perfect, operating on about eighty per cent efficiency.

Neither Mr. Brown nor Professor Kneipp can give any detailed description of this system now because the University desires first to publish the results of their research work in a university bulletin. This may not be done for another year as the appropriation for printing this bulletin has been depleted.

Progress of Tests to Date

Observations taken during the Radiocasting from WRM reveal the new system to be more selective and that it is possible to allow sharper tuning with

stronger signals. No tuning curves have been obtained as yet, and no measurements have been made with an audibility meter.

The probable range has not been measured with any instruments as yet, but, mathematically it is far superior to the present ranges as well as consuming less power. The system, Mr. Brown claims, will tend to eliminate fading signals which he believes to be nothing more or less than carrier wave phenomenon.

Experiments on this system are expected to stop shortly, it is to be regretted, owing to lack of university funds appropriated to carry on the work.

Loop Selectivity with Volume

The greatest objection to the use of a loop aerial in securing maximum selectivity is the loss of volume. When difficulty is experienced from the interference of two or more stations near the same wavelength, or when the static becomes so heavy as to drown out even the locals, the trouble may be reduced at least 75 per cent by closing the ground switch, thus grounding the aerial, and connecting the set to a 3 or 4-foot loop of 10 or 12 turns, shunted by a variable condenser, the loop to be placed as near as possible to the wire connecting the aerial to the ground.

Using an ordinary three-circuit tuner and a WD-11 tube I regularly receive a thousand miles through static that would make reception impossible otherwise, and also cut out code interference practically entirely. The method is equally efficient with a two-circuit set, the only requisite being that the loop be not more than 2 or 3 feet from the ground wire. A plaster wall separating them seems to make no difference, however.—Floyd A. Aleck, Rockbridge, Illinois.

A Suggestion

Before winding a coil with white covered wire, wash your hands and put some ordinary talcum powder on them. This will prevent the covering on the wire from becoming soiled from perspiration on the hands, and the coil will be more perfect electrically.

BUELL

RADIO APPARATUS

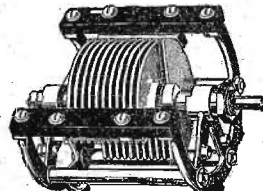

THE MOST STURDY
of the New Type
LOW LOSS
CONDENSERS

BUELL MANUFACTURING CO.
2977 Cottage Grove Ave., CHICAGO

RADIO By Mail

OUR NEW CATALOGUE

Is the most complete list of RADIO SETS and PARTS ever published and contains hundreds of articles which are used daily and are not sold by many firms.

BE CONVINCED
Send 4c for your copy today and let us prove it.

TELEDYNE KIT 1-Special tuning coil and 8-Special R. E. coupler (Wound with green silk wire on BA-KALITE tubing; complete with brackets, etc.)	\$6.39
COCKADAY PARTS	
ERLA Green silk wire on BA-KALITE.....	\$ 3.19
LAVITS resistances, 45000-ohm.....	.85
AMPLEX Grid-condensers.....	.89
AMSCO 25 Plate variable condensers.....	3.05
Bradley-Ohm (No. 10, No. 25 or No. 50).....	2.00
COMO duplex audio transformers (per pair).....	9.29
ULTRADYNE KIT Consists of 1-4500 "A" Ultraformer, 3-4-type "B" Ultraformers, 1 tuning coil, and 1 os. 20.58 Effector coil (coil silk on BA-KALITE)..... Set of 4-Ultraformers.....	20.58 1.25 \$16.76
ERLA REFLEX PARTS	
ERLA reflex or audio transformers.....	\$ 3.89
ERLA "SELECTORFORMER".....	3.99
ERLA Crystal Detector.....	.75
RATHBUN condensers, 11-PI., \$2.39. 20PI., 2.79	
HARKNESS REFLEX KIT Consists of 1-4500 "A" Ultraformer, 3-4-type wound transformers mounted on condensers (coil around silk on BA-KALITE Tubing); Transformer coil separate, set.....	\$6.79 2.24
BURGESS large 22½-V "B" Batteries.....	1.89
BURGESS large 45-V "B" Batteries.....	3.68
"SUPERDYNE" Special coupler.....	4.89
"Good Seal" Hertz.....	15.95
HAMMARLUND CONDENSERS	
Plain, 11-PI., \$3.78 23-PI., \$4.19 43-PI., \$5.04	
Vernier, 11-PI., \$4.62 23-PI., \$5.04 43-PI., \$5.88	

Prices F.O.B. St. Louis, Mo., Cash or C.O.D.
SIMPLEX RADIO SALES CO.
1808 Lafayette Ave. Dept. D ST. LOUIS, MO.

BEWARE of Imitations!

The UNCLE SAM MASTER TUNING COIL is the original 3-circuit tuner. Demand only the genuine if you want VOLUME, DISTANCE, SELECTIVITY.

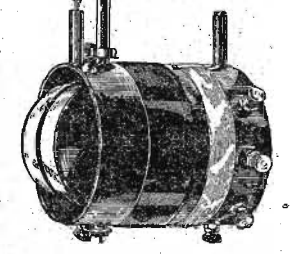

UNCLE SAM MASTER COIL

Verifications from satisfied users prove conclusively such DX Reception as Philadelphia to KFAX (Pullman, Wash.), Ardmore, Pa. to WKAQ (Porto Rico), Trenton, N. J. to KHL (Los Angeles). And as to selectivity, a committee of engineers in Philadelphia clearly heard 49 different stations sign off in 8½ hours on the air.

The only licensed all Litz Tuner
Only \$5.50
At all good dealers

Ask your dealer or send self-addressed, stamped envelope for free wiring diagrams of circuits using this coil.

UNCLE SAM ELECTRIC CO.
217 E. 6th St. Plainfield, N. J.

The "Goode" Two-o-One

A
Le Ton d'argent

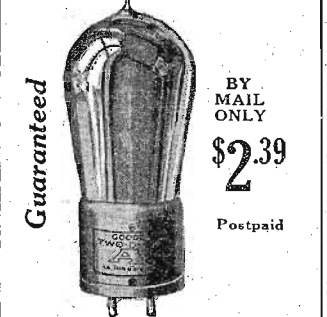

QUARTER AMPERE RADIO TUBE

GUARANTEED SATISFACTORY

All "GOODE" Tubes Sold Direct to the Consumer—No Dealer Profits

One—"Goode" Detector-Amplifier..... **\$2.39**
Three—"Goode" Detector-Amplifiers..... **6.42**
(All postage prepaid)

The "Goode" Two-o-One A Tube amplifies or detects. It is a quarter ampere, 110 volts, standard base silvered tube.
Send express or postal money order or New York draft to:

The Goode Tube Corporation
Incorporated
EVANSVILLE INDIANA

THIRTY-MINUTE A-B-C

(Continued from page 13)

which is not neat, messy looking soldered joints inside, loose parts, flimsy construction, etc. Sets intended for use with dry cell tubes preferably have some shock absorbing socket mounting, as such tubes "ring" when subjected to mechanical shock. If you buy a set or have one assembled for you, be sure to have the terminal posts clearly and correctly marked. Thousands are in use with improper marking, if any at all. Someone not familiar with the set changes the batteries, connects the B battery wrong, and the tubes are burned out. Use the same sense in choosing a radio outfit as you use in buying your new car.

In the next issue Mr. Edelman gives good advice to the beginner in making his own receiving set. Tells what to do and what not to do, faults in soldering and how to follow and make up layouts. There will be a great deal of valuable information to those intending to make their own sets.—Editor's Notes.)

NEUTRALIZING SUPER

(Continued from page 7)

C4, .006 mfd. fixed condenser, mica dielectric.
R1, R2, R3, R4, R5, 25 ohm. rheostats.
R6, 1/4 10 megohm variable grid leak.
S1, S2, S3, A battery switches, push pull type.
AET, 1, 2, 4 1/2 to 1 audio frequency transformers.
J1, J2, Double circuit jacks.
J3, Single circuit jack, open type.
Five standard sockets.
Five 201-A or 301-A tubes.
C7, .00025 fixed condenser, mica dielectric.
Two 45-volt and one 22 1/2-volt B battery.
Storage A battery, 6 volt.
20 feet tinned bus bar wire.
8 binding posts.
Three mechanical vernier adjusters, if desired.

7 by 28 inch panel.
6 by 26 inch baseboard.
7 1/2-volt C battery.
1 bakelite strip, 1 by 6 inches.
1 bakelite strip, 1 by 2 inches.
3 3-inch dials.

(With this sketchy outline of what the neutralized super is, what it does and the list of parts required, the prospective builder is asked to wait patiently for the next issue of the Radio Digest, when he will be led further into its mysteries. That issue will contain the panel and baseboard layout.—Editor's note.)

REVIEW OF BOOKS

Home Radio—How to Make It. By A. Hyatt Verrill. This book is particularly adapted for the amateur who desires to know how to make Radiophones. Twelve full page illustrations and diagrams. Price, 75 cents.

Radio for the Amateur. By A. H. Packer and R. R. Haugh. The underlying principles of Radio thoroughly explained in simple language and understandable illustrations. This book will teach you how to construct and operate a receiving set successfully. Price, \$1.50.

Radio Reception. By Harry J. Marx, Technical Editor Radio Digest Illustrated, and Adrian Van Muffling. A simple treatise on Radio reception. Beginning with the elementary principles of electricity it carries the reader on into the essentials of Radio telephony. The most successful methods of Radio reception are explained and special attention given to practical tuning. Price, \$2.00.

Elements of Radio Communication. By Ellery W. Stone. A splendid, well connected, complete, accurate and up-to-date discussion of every phase of Radio telegraphy and Radiotelephony. Written in simple language. The subject is presented from the physical rather than from the mathematical standpoint, avoiding the use of higher mathematics. Price, \$2.50.

Within the Atom. By John Mills. May be read by the Radiophan with interest for it deals with that infinite particle as associated with electrons, and all chemical and all electrical phenomena. Price, \$2.00.

Experimental Wireless Stations. By P. E. Edelman. Simple directions are given in this book for making Radio equipment for the transmission of messages over long distances. Price, \$3.

How to Retail Radio. A new book telling of tested plans and methods and policies for the dealer in Radio. Financing, location, store equipment and arrangement. Price, \$2.

The Radio Manual. By Orrin E. Dunlap, Jr. A 268 page book profusely illustrated. Tells of Radio from the beginning to the

end in non-technical terms. Price, \$2.50.
Storage Batteries. By George Wood Vinal. Any person owning a Radio receiving set needs this book for it tells about the power that brings in the messages. Most of us know too little about the heart of the set—the storage battery. Price, \$4.50.

Amateur Radio Call Book. We have a few copies of this valuable book of the fourth edition. It contains a list of amateurs, special amateurs, technical and training stations. Tells how to construct a Reinartz tuner, detector and amplifier. A two-color map comes with it. Original cost, \$1. While they last, 50 cents.

The book department of the Radio Digest is prepared to send you any of the books on Radio published, whether listed in our Book Review or not. Let us know what book you want, send us your check and we will see that the book is mailed to you. Postage stamps in payment for books not accepted. Send money order or check. Radio Book Department, Radio Digest, 510 N. Dearborn St., Chicago, Ill.

Pfanstiehl
PURE
INDUCTANCES

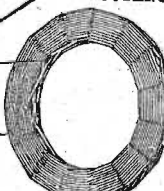

	Turns	List Price	Wave Length
P-201	23	\$ 1.00	340
P-202	35	.59	125-470
P-203	50	.85	170-650
P-204	75	.74	220-960
P-205	100	.90	300-1300
P-206	150	1.10	470-1950
Pfanstiehl Ultra-Audion		.95	
Pfanstiehl Reinzart		1.75	

Pfanstiehl Tuning Unit, consisting of 2 Spooler Web Coils with mechanism for \$5.00 supremely sensitive adjustment.

At all good dealers or direct on receipt of purchase price

PANSTIEHL RADIO SERVICE CO.
Highland Park, Ill.

MAGNATRON

MAGNATRON DC-199 knows no superior among dry cell tubes. Whether as detector or as amplifier, it will give better results in your set. It and the MAGNATRON DC-201A are unqualifiedly indorsed by experts.

Your dealer has these tubes. They list at \$5.



CONNWEY ELECTRIC LABORATORIES
309 Fifth Avenue NEW YORK CITY

Build a FADA 5 tube Neutrodyne Receiver

You can assemble one in a few hours. For distance, selectivity and loud speaker volume there's nothing better. The FADA 5-tube Neutrodyne outfit No. 167-A contains everything needed—the finest Neutrodyne parts that can be purchased. The FADA "How to Build It" book makes everything as simple as A, B, C. Buy the original FADA No. 167-A in the sealed package, \$65.50.

F. A. D. ANDREA, INC.
1581 Jerome Ave. New York

FADA Radio

Radio Dealers HEADQUARTERS



EIGHT BIG WAREHOUSES TO SERVE YOU

DEALERS Write on your letterhead for this big catalog. Ask for A1002

WAKEM & McLAUGHLIN
225 E. ILLINOIS ST. - CHICAGO

HAVE YOU SEEN? THE CARTER Jack Switch



\$1.00

Simple to mount. No loose joints or screw connections. Noiseless operation. No sliding contacts to wear. Positive connection. Wide spaced solder terminals.

Insist on the Original. Any Dealer Can Supply

Carter Radio Co.

MICADONS

The standard fixed condensers of radio. In use in more than 90% of all sets made. Easily installed. There is a Micadon for every circuit

Dubilier
CONDENSER AND RADIO CORPORATION

Built by Radio Engineers

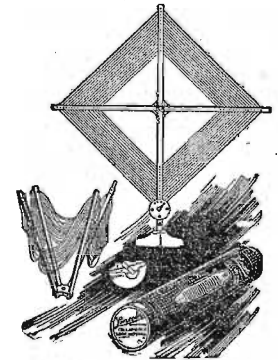

Lincoln Collapsible Loops offer many advantages appreciated by Radio Engineers and Radio enthusiasts. They are built for those who demand the best. Wire length range with 23 plate condenser is 100 to 600 meters.

H. F. resistance at 400 meters—only 7 ohms.

Wire is stranded, flexible and of great tensile strength and high conductivity. Inductance 2 millihenry.

Lincoln RADIO PRODUCTS

Great Selectivity—No Static

Lincoln Collapsible Loops fold completely—and are ideal for summer use. Great selectivity—no static—quality reception—and no unwanted interference. If your dealer cannot supply you, order direct, giving your dealer's name.

Tapped Loop \$8.00
Without taps \$6.50

FREE BOOKLET
Write for the Lincoln Booklet—sent free. Shows best circuit hook-ups—and also illustrates Lincoln quality apparatus.

Lincoln Radio Corporation
224 N. Wells St. Chicago, Ill.

Manufacturers of:
The "Long 45" Tuner—Lincoln Kit—The Oscilloscope
Lincoln Low-Loss Variable Condenser

What Is Your "B" Battery Cost?

The Kellogg Trans-B-former furnishes necessary plate voltages from your 110 A. C., 60 cycle electric light socket at the lowest possible cost and with improved reception.

This noiseless "B" Battery supply set assures constant voltages at all times. Arranged for detector (0 to 35 volts), 45, 90 and 130 volts.

The Trans-B-former was designed and developed by the Kellogg Switchboard and Supply Company and fulfills every requirement for furnishing plate current for both detector and amplifier of your receiving set.

It is neatly arranged in a heavy quarter-sawed oak cabinet, with glass cover. The binding posts are clearly marked with the voltage output.

Positive in operation and one of the biggest advances in radio today.

AT YOUR DEALER'S, \$50.00

KELLOGG SWITCHBOARD & SUPPLY COMPANY
1066 W. Adams St. CHICAGO, ILL.

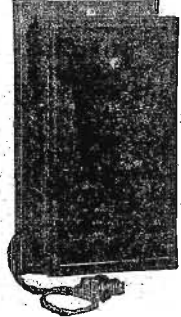

EVEREADY Radio Batteries
—they last longer!

Conspicuous for vitality and endurance—the right batteries by test and proof for every radio use.

NATIONAL CARBON CO., INC.
Headquarters for Radio Battery Information
New York San Francisco
CANADIAN NATIONAL CARBON CO., LIMITED
Factory and Offices: Toronto, Ontario

Lincoln Radio Corporation
224 N. Wells St. Chicago, Ill.

Manufacturers of:
The "Long 45" Tuner—Lincoln Kit—The Oscilloscope
Lincoln Low-Loss Variable Condenser

Erecting Staffs for Aerial Wire Ends

Aerial Repairing Made Easy With Lift Support

The average fan is content to use a makeshift aerial staff or support. As I was one of this class I used everything from clothes line poles to my neighbors

WORKSHOP KINKS EARN A DOLLAR—

THERE are many little kinks worked out at home that would aid your fellow Radio worker if only he knew about them. There are new hook-ups, new ways of making parts and various unique ways of operating sets that are discovered every day. Radio Digest is very much interested in obtaining such material. Send them in with full details, including stamped envelope, so rejected copy may be returned. The work must be entirely original, not copied.

RADIO KINKS DEPARTMENT,
Radio Digest,
510 North Dearborn St., Chicago

chimneys, finally I decided to erect two permanent staffs that could be raised or lowered single handed.

The illustration shows one of the staffs which is 40 feet high, and when raised it rigidly supports a taut aerial and it has no unsightly guy wires. The parts E to F consist of two 2 by 4 inch pieces 20 feet long attached together with blocks 2 by 4 inches and 8 inches long thus making a space for the end of the upper part of the staff. Both of the top staffs are made of one piece of 2 by 4 inch material cut slanting or diagonal for length which makes two pieces 24 feet long between A and N. The piece B to D is a brace supported by a metal shelf bracket. Near its end there is a hole through which a double wire running from A to B and C can be used to hold the staff rigid. By twisting this wire the top part of the staff can be straightened and the aerial slack taken up.

Erection of the staff is simplicity itself.

RAISING AND LOWERING SUPPORT

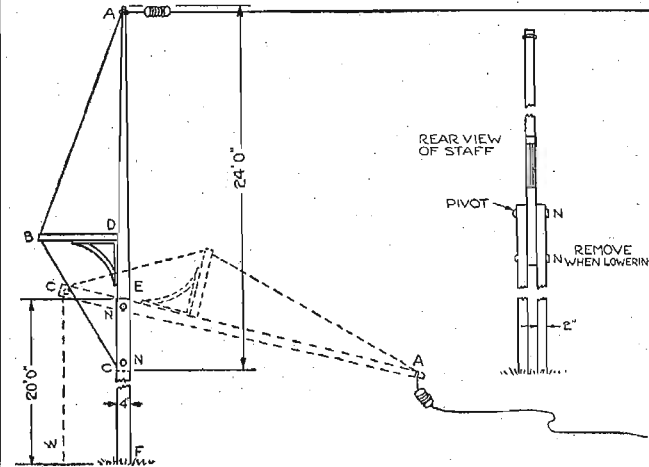

The lower pieces, after being nailed together, are bolted in or to any solid foundation such as a garage and the house, or anything with suitable strength. A ladder is then placed against this and the top staff brought up. The holes N are for bolts. The upper bolt is placed in position and it acts as a pivot when the staff is to be lowered. Pull on the wire W and the top of the staff is almost swung into position, then at this point make the wire W fast and mount the ladder, grasp the brace at the point B and the staff will easily come into position so that the lower bolt N can be inserted.—R. J. Broussard, New Iberia, La.

Ground metal masts when used to support an aerial.

Use of a Wave Trap as a Coupler in Tube Set

While experimenting with a compound wave trap consisting of two loosely coupled coils, one of which was tuned with a .0005 variable condenser, I conceived the idea of using the wave trap as a coupler for a crystal set when the tube set was not in use.

Upon trying it out it was found that it worked fairly well. They say that small things lead to greater ones. I believe it is so, for later on I tried tuning in with the tube set while the crystal set was in operation and found that I could not only receive two stations at once but that somehow the tube set in-

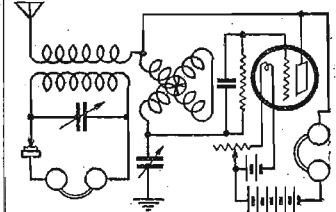

creased the volume of the crystal set almost three times.

It was found, however, that allowing the tube to oscillate destroyed the sensitivity of the crystal at that particular point. With this I have repeatedly received two stations varying widely as to wave length and over far greater distances than a crystal set is supposed to receive.—Earl Lett, Cherryville, Kansas.

Use sealing wax to hold the ends of the coil winding in place; do not use shellac on any windings.

S. HAMMER RADIO CO. 303 Atkins Ave., Brooklyn N. Y. STANDARD SUPERDYNE 4-TUBE

Knockdown Kit—Complete Parts
More powerful than a 6 tube naval receiver. Easy to build.

- 1—Superdyne Coupler
- 2—23-Plate Variable Condensers
- 1—Variable Grid-Lens
- 1—50025 mfd. Fixed Condenser
- 3—Rheostats
- 4—V. T. Sockets
- 2—Aero Audio Transformers

Wired Complete in Genuine Mahogany Cabinet... **\$45.00**

3 TUBE COCKADAY 4 CIRCUIT TUNER

- 1 Precision Coil
- 2 Amco 26-Pl. Conds.
- 1 Dubilier 5000 Fixed Condenser
- 1 Variable Grid-Denser
- 1 Grid-Leak
- 2 Melo Sockets
- 1 Aero Double Jack
- 1 Patent Spring Jack
- 2 Aluminum Transformers
- 1 Amco Switch Lever
- 1 Baseboard
- 1 Wire, Diagram, Etc.

SPECIAL KIT \$35.00 Wired Complete in **\$53.00**
PRICE Mahogany Cabinet

Orders over \$5.00 will be shipped prepaid. Money orders or C. O. D. Not insured unless insurance charges included. Write for Price List.

Modified Set for Short Waves

An amateur some 250 miles from Paris announces that he has found the simplest way to receive the short waves of the new stations, most French sets now existent having been built for long waves rather than short.

The device is to take out the first tube. With the plate and grid terminals of this tube short-circuited, using only a detector, he receives all waves down to 245 meters and gets excellent selectivity. His set has one stage of Radio frequency, a regenerative detector, and one stage of audio frequency. It is connected to a two-wire, 50-foot galvanized iron aerial.

Guaranteed Head-sets

RED-HEADS' are guaranteed radio phones. You run no risk when you buy them. Money back if you are not satisfied that you're the best receivers on the market at the price. Why not act right now and get a pair? It'll mean getting the maximum from broadcasting from the day you put them into use.



RED-HEAD RADIO RECEIVERS NOW READY

The new 1924 Model F The new "Red-Head" Jr.
\$6.50 Per Pair **\$5.00 Per Pair**
Complete Complete

"Red-Heads" sent prepaid on receipt of price if you are unable to get them at your dealers.

THE NEWMAN-STERN COMPANY
DEPT. R. D., NEWMAN-STERN BUILDING, CLEVELAND, OHIO

Duo-Reflex

Tube for Tube—the Most Powerful Circuits Ever Built. Write for free Bulletin No. 16
Electrical Research Laboratories
CHICAGO. ERLA

Two tubes do the work of five—

Watch for announcement in August 30th issue of Radio Digest.

SHAMROCK MANUFACTURING CO.
Dept. 26-A, Market St. Newark, N. J.

SHAMROCK

(FOR SELECTIVE TUNING)

KEYSTONE RADIO LIGHTNING ARRESTERS

\$1.50
At All Dealers

Buy your Keystone Arrester today—install it according to instructions supplied, and forget about lightning. Made of Bakelite—weather-proof. No vacuum to lose. Approved by Underwriters. At all Dealers, \$1.50.

Manufacturers of over a million Lightning Arresters

ELECTRIC SERVICE SUPPLIES CO.
17th and Cambria Streets, Philadelphia
58 W. Jackson Blvd., Chicago
50 Church St., New York

What About It?

Isn't it about time to stop experimenting with multiple control circuits and build one that, combining ease of assembly and operation, loudness, clarity and selectivity of signals, as well as beautiful appearance, is excelled by none?

THE ELGIN SUPER-REINARTZ RADIO RECEIVING SETS

Embodies all the advantages of the well known Elgin Reinartz set which was largely responsible for the popularity of this wonderful circuit and many others. It is much louder, more selective, requires no storage battery, and can be used with excellent results on a short or loop aerial.

It has brought in 2LO England, and California stations two thousand miles from Elgin, clearly and without interference on a loud speaker with only one tube, and that while our powerful loop station was broadcasting three miles away.

Could you ask for more?

Send 2-cent stamp for circular giving one, two and three bulb hook-ups of this remarkable circuit.

ELGIN RADIO SUPPLY CO.
207 East Chicago Street ELGIN, ILLINOIS

B-METAL Crystals of Quality

Trade Mark Reg. U. S. Patent Office.

The B-METAL Lead-Talking Crystal was the first really standard crystal offered under a reliable "complete satisfaction guarantee" and it spread its immediate popularity, remaining at present in constant demand. It has no equal in any standard priced and quality crystal.

B-METAL has kept pace with developments and has constantly been improved by the use of purer base materials, scientific treatment, and more care in inspecting and testing. The quality has gone up 100% and the price is still 50 cents.

No premiums are offered to sell B-METAL, nor can Genuine B-METAL Crystals be bought at less than standard price.

If your dealer cannot supply you, send to us. We will send one only to anyone willing to send us a return to pay promptly if satisfied.

Send us every Radio owner to know what B-METAL Crystals are. Write today.

Dealers and Jobbers please get our proposition

B-METAL REFINING CO.
14 N.W. 525 WOODWARD AVENUE
DETROIT, MICHIGAN

Dealers Need This

200% Profit

The new FAHNESTOCK Display Case

Will stimulate your sales of Famous Radio Products. It is the most popular style and sizes are included. Shows the purchaser instantly the correct piece for his set. A constant invitation to buy Famous Radio Products. Dealers are offered 200% profit on each case, an unusual offer on standard merchandise.

Price to Dealer.....\$17.50
West of Mississippi..... 18.50
Transportation prepaid when money order or check accompanies order. Subsequent orders at regular price of \$20.00.
Contents Retail for \$51.50

Really will be supplied at the regular 100% list price, shown in catalogue, which comes with one less discount shown on enclosed sheet. Send check or money order today.

FAHNESTOCK ELEC. CO.
LONG ISLAND CITY NEW YORK

Questions and Answers

Five-Tube Circuit (3542) LB, Chicago, Ill.

Would you kindly advise me where I could secure a good, clear diagram for a five-tube Armstrong hook-up comprised of the following: 2 stages Radio frequency, detector, 2 stages audio frequency,

recognized as a 60 cycle hum and which has baffled all efforts to localize or locate. One or two transformers have been found defective and a few cases of leaky insulators remedied, but the real trouble has not been fixed. Recently about half of the city was entirely blanketed by a

any details which would help us in tracing and fixing our trouble here. I understand our street lighting circuit is an old arc series circuit with incandescent lights placed where the arc lamps were. A small safety fuse is out at these incandescent lights which fuses above

of induction from all possible points it can usually be traced down to a confined area. The best procedure is to determine which locality is most effected and start from there as it is bound to be located in proximity to this position. The sources are found often in a swinging tree branch scraping up against a high tension wire, or a grounded or leaking electric street lighting pole will sometimes be found to be the cause.

As in your experience, it is evident that the entire service system is at fault. This of course necessitates the co-operation of power plant engineers. It is advantageous to make a map of the district, taking readings of comparative intensity and subsequent readings provide a determination of exact location.

The situation is a difficult one to combat and the measures offered are the only ones at your command.

Amplifier Noise (8491) WK, Hopkins, Mich.

I have a 4-tube set, 1 stage of Radio and 2 stages of audio. I can turn the first amplifier and detector out and the audio tubes make a noise like oscillation which bothers much in evening. I am using 100 volts on plate. Tell me the cause of this noise.

A.—The action of audio frequency amplifiers with Radio frequency stage and detector tube turned off as described is characteristic. Why turn off the detector tube? You could not accomplish reception without it.

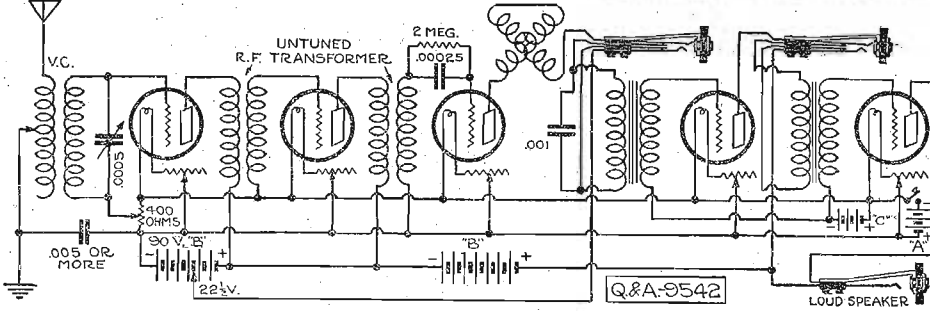

variocoupler—coil tapped every 10 turns, rotor tapped every 15 turns, 2 25-plate variable condensers and 1 variometer.

The variometer I now have is a grid type. Could this be used or should I have a plate variometer? I am perfectly willing to pay for the diagram provided I can get a good one using the above parts. Wish to construct this set through the summer for next fall, and have had such good results with my two-tube Armstrong, not interested in any dynes or flexes.

A.—We are presenting a diagram of an effective circuit to meet your specifications. The necessary details are marked on the hook-up. Your variometer can be used in either grid or plate circuit.

Buzzing Noises (8690) HWK, Des Moines, Iowa.

On the front page of your issue of March 23, I see an article stating that Columbus, Ohio reception was greatly improved by clearing up faulty grounds in the lighting circuit. Des Moines Radiophans have been greatly troubled during the past several months by a buzzing noise which was

noise which drowned out all reception. We tried to locate this with a loop but the noise showed no direction at any point and very little difference in intensity. From a steady grind, this has now been reduced to an intermittent noise and we are at a loss to know how to go at locating and remedying the trouble. A few small sections of the city have had a noise which prevented Radio reception all winter. At other points, the noise comes and goes but is the worst in the earlier hours of the evening.

If you have the information at hand, I wish you would either publish or let me know what means were taken to locate the trouble at Columbus, the kind of circuit in which the trouble was centered and

when the lamp is burned out. We have heard of some cases where trouble was located at these fuses.

A.—The method used for locating the actual source of your trouble is that of the familiar direction-finder. A sensitive receiving set connecting to a rotatable loop aerial is mounted on an automobile and by taking direction bearings on the source

"CRYSTAL Sets Tested 600 Miles." You can now get a genuine Lambert Long Distance Crystal Radio Set for only \$4.98. Particulars free. Leon Lambert, 501 Volusia, Wichita, Kansas.

Don't You Get Tired

of only hearing LOCAL stations on your Crystal Set? Hear the music on your aerial every night from stations far away. If you want to hear it without buying a tube set, WRITE ME TODAY.

LEON LAMBERT
501 South Volusia Wichita, Kansas

PROGRESSIVE DEALERS everywhere buy RADIO SUPPLIES from CLARK & TILSON, INC.

The Nationally Known House
554 Seventh Ave., N. Y. C.
Send for price list and discount sheet.
Wholesale Radio Supplies of national reputation since 1921.

Large Radio Wall Map

FREE The very latest up-to-date radio wall map 24 by 34 inches. Shows call letters, locations, wave lengths, and frequencies of all radio broadcasting stations, U. S., Canada, and Mexico, relay stations, radio articles. Also a scale for measuring distances. This wonderful map postage paid, ABSOLUTELY FREE. Wonderful map postage paid, ABSOLUTELY FREE. Wonderful map postage paid, ABSOLUTELY FREE. Wonderful map postage paid, ABSOLUTELY FREE. Wonderful map postage paid, ABSOLUTELY FREE.

OSZARKA INCORPORATED
808 Washington Blvd. Chicago

Bankrupt Stock

Cunningham Regenerative one tube long range sets \$9.00 Each

Formerly sold at \$32.50
No Circulars. Order from This Ad. This set with tube, phones, all batteries and aerial complete, ready to use, for \$21.00

Prepaid while they last.
S. A. TWITCHELL
1925 Western Av., Minneapolis, Minn.

S. & H. "B" BATTERY

"Will Keep Your Set Alive"

is "NOISELESS," increases volume and range with maximum clearness. Made of the finest material to give extra service. Lasts not two days old when they're sent to you.

22 1/2 V. Variable
Large M'd'm Small
\$1.80 \$1.60 \$1.00
45 V. Variable
Large M'd'm Small
\$3.60 \$2.75

Sold with a Money-Back Guarantee. We Pay Postage
S. & H. BATTERY SUPPLY CO.
41 Navis St., Dept. (D) Brooklyn, N. Y.

PRE-AMPLIFIER

Registered

Makes Summer Radio Practical
THE TWITCHELL PRE-AMPLIFIER is a powerful Radio Frequency Amplifier attachable to any receiving set. It brings in many distant stations which you cannot hear without it. Brings in with tremendous volume those you now hear only faintly. Makes your set selective. Prevents re-radiation.

Price complete with tube \$25.00
Shipped Prepaid
S. A. TWITCHELL
1925 Western Ave. MINNEAPOLIS, MINN.

HUDSON-ROSS

Sells only Guaranteed Radio Apparatus
and Radio Accessories

123 W. Madison St. Chicago

500 RADIO DEALERS
BUY FROM
HUDSON-ROSS
123 W. Madison St. Chicago
and the nearest branch

Largest Radio Jobbers in Middle West

123 W. Madison St. Chicago

PATENTS

Procured. Send sketch or model today for examination. No report and advice. No charge for preliminary advice. Write for free booklets "How to Obtain a Patent" and "Invention and Industry" and blank form on which to disclose your idea. Highest references. Promptness assured. Clarence A. O'Brien, Registered Patent Lawyer, 2093 Security Bank Building. Directly across street from Patent Office, Washington, D. C.

SOLDERING HINTS

Jones' Solder-Eze is recommended as a flux for particular radio electrical soldering. Your sets under heat from iron, thus no corrosion. Easy to apply and grips like a vise.

In Bottles 50c
JONES' SOLDER-EZE COMPANY,
105 Tipton Street,
Johnson City, Tenn.

WHOLESALE ONLY!!

If you are contemplating going into the RADIO BUSINESS. SEND FOR OUR NEW ILLUSTRATED CATALOG, WITH BARGAIN PRICES. **MANHATTAN RADIO CO.** 112 Trinity Pl. New York City

RADIO HANDBOOK

Only \$1 514 PAGES

Just off the press! The greatest book on Radio ever written. Price only \$1. Filled with sound, practical, tested information for every radio fan, from beginner to hard-boiled owl. Written, compiled, and edited by men of national reputation. Every page tells you something useful—and there are 514 pages. Mail \$1 to-day and get this I. C. S. Radio Handbook before you spend another cent on parts. Money back if not satisfied.

INTERNATIONAL CORRESPONDENCE SCHOOLS
Box 8278-L, Newark, Penn.

I enclose One Dollar. Please send me the I. C. S. Radio Handbook. It is understood that if I am not entirely satisfied I may return this book within five days and you will refund my money.

Name.....
Address.....

Workman Radio Service

"THE ACCENT IS ON SERVICE"

14-16 Vesey St. NEW YORK

VARIOCOUPERS	
\$3.50 Workite 180" Silk Wound.....	\$2.95
3.50 Fisher, 180".....	2.75
2.75 Fisher, 180".....	2.25
4.25 Special Blank Wound.....	3.25
Haynes Circuit (with diagram).....	3.25
7.00 Ambassador Coil (with diagram).....	5.30
VARIOMETERS	
\$3.50 Workite.....	\$2.95
5.00 Pathé Mounted.....	2.25
3.50 Fisher, Large.....	2.85
CONDENSERS	
\$2.00 R. C. 11 plate.....	\$1.05
3.25 R. C. 23 plate.....	1.25
3.75 R. C. 43 plate.....	1.65
VERNIER CONDENSERS	
\$4.00 R. C. 23 plate.....	\$2.25
5.00 R. C. 43 plate.....	2.55
PHONES	
\$18.00 DR. SEIBT IMPORTED "SUPER".....	\$6.90
\$12.00 N. & K., Imported.....	\$6.90

The above items are just a few of our numerous attractive priced articles, which are contained in our BULLETIN OF RADIO PARTS. Gladly send to you upon request.

We are headquarters for "Radion" and "Bakelite Difuser" Parts. The best price material available. Mail orders promptly attended to. Will ship C. O. D. unless remittance accompanies order.

The New STAR Type E. Detector

For Crystal or Reflex Sets

Price \$1.00

Star Type E Detector

WE offer the STAR Type E Detector which is covered by our guarantee of complete satisfaction and is sold at the LOWEST PRICE of any RELIABLE DETECTOR on the market. This detector is well made and is set with one of our very best receiving materials. It is made so that in case of necessity it may be adjusted and while it is not especially designed for reflex sets many excellent reports of performance on these sets have been received.

THE TYPE E DETECTOR IS THE BEST BUY IN THE CRYSTAL MARKET TODAY and will be sent subject to exchange for any other item we make.

DEALERS send-to-day for our FALL CATALOGUE NOW READY, and get all set for the big season ahead.

Star Crystal Co.
1401 525 Woodward Avenue
DETROIT - MICHIGAN

WE REPAIR THE FOLLOWING RADIO TUBES

Dealers and Agents write for Special Discount
Mail Orders Solicited and Promptly Attended to

WD-11	\$2.50	DV-6A	\$2.50
WD-12	2.50	UV-199	2."
UV-200	2.50	C-299	2."
UV-201	2.50	UV-201A	2."
C-300	2.50	C-301A	2."
C-301	2.50	Marconi	2.50
DV-6	2.50	Moorhead	2.50
DV-1	2.50	6 V. Plain Det	2.50
DV-2	2.50	6 V. Plain Amp	2.50

H. & H. RADIO COMPANY
P. O. Box 22-A
Clinton Hill Station NEWARK, N. J.

Radio Illustrated



This little miss knows all about Radio waves. Her name is Margery Weingart and she can tune her set as well as any grown-up. International.

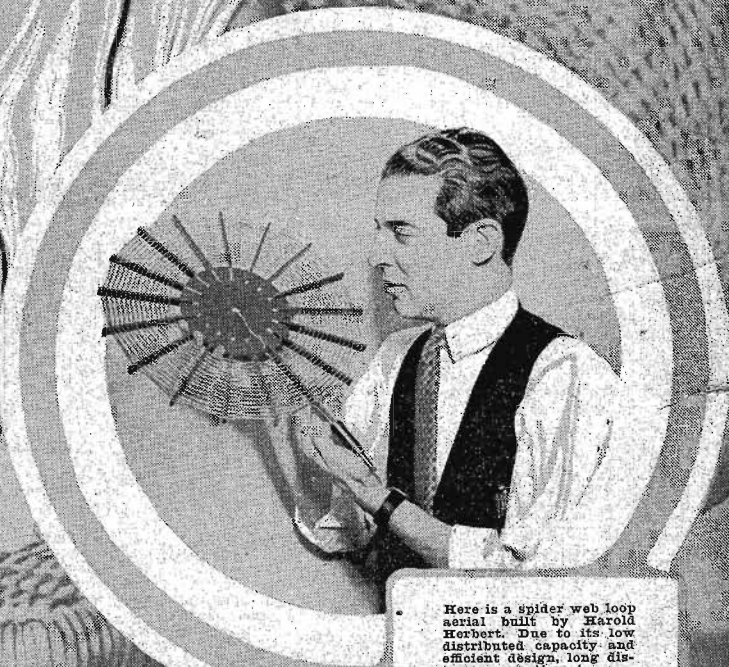

Here is a spider web loop aerial built by Harold Herbert. Due to its low distributed capacity and efficient design, long distance reception is possible. K. & H.



This jolly trio is composed of Alec de Gooze at the washboard, the Radio set and Otto Weisenseel with the banjo. Foto. Topics

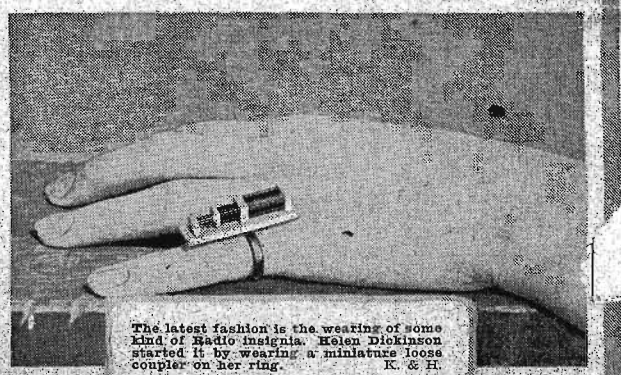

The latest fashion is the wearing of some kind of Radio insignia. Helen Dickinson started it by wearing a miniature loose coupler on her ring. K. & H.