

Solution of "Step On Stairs" Mystery

# Radio Digest

TWICE  
A MONTH

PROGRAMS  
Illustrated

FIFTEEN  
CENTS

Vol. XVII Copyright 1926 by  
Radio Digest Publishing Co.

FIRST MAY NUMBER, 1926

Title Reg. U. S.  
Pat. Off. &  
Dom. of Canada No. 4



*Hugh Fullerton's "Big Rabbit," a Romance; WLS Homemaker Gives Cheer to June Brides; Burying the Demon Static; "High-Brow" KMTR's Story; Photos of Famous "S-O-S" Casts*

# No. 6 OFFICIAL BALLOT Announcers' Contest

## RADIO DIGEST THIRD ANNUAL GOLD CUP AWARD

GOLD CUP AWARD Editor, Radio Digest,  
510 North Dearborn Street, Chicago, Ill.

Please credit this ballot to:

..... of Station.....  
(Announcer's Name) (Call Letters)

Signed.....

Address.....

City..... State.....

6-1-28

## WJAZ IS ACQUITTED OF 'PIRACY' CHARGE

### COURT FINDS THAT ZENITH ACTS WITHIN THE LAW

Case Shows Inadequacy of 1912 Regula-  
tions—Encourages Advocates of  
Communications Commission

CHICAGO.—The "pirates" of the air have been vindicated. WJAZ can choose any wave length it desires and broadcast at any time it wishes, according to the recent decision of Federal Judge James J. Wilkerson who holds that the Zenith broadcaster is not guilty of a criminal act, and that the actions of the station are within the limitations of the law as it now exists.

The United States government, and specifically the department of commerce, which sought to punish WJAZ and its owners for taking the wave length of 229.5 meters without permission from the commerce department, is the loser of the test suit. The government cannot appeal the decision of one of its own judges.

The 1912 Radio law, the only congressional act by which Radio stations can be regulated, will therefore allow all Radio manufacturers who maintain some experimental work, and all Radio communication companies (which would mean essentially the R.C.A.) to pick their waves and hours, and the department of commerce can do nothing.

**Broadcasting Stability Not Threatened**  
But broadcasters other than those which fall within the classes outlined, must stay on their assigned waves and schedules of operation. KWKH, the Shreveport, La., station, which has been reported to have adopted tactics similar to WJAZ, will no doubt be liable to punishment and confiscation of equipment.

The 1912 Radio law is old and peculiar, however, and many loopholes are left by the fourteen years of Radio progress which have passed by congress without that body realizing it. Perhaps KWKH—and others who decide to try their luck—may succeed unharmed. The next few weeks will tell.

#### Secretary Hoover Hit by "Brick"

The decision will not, it is believed, cause many stations to shift their wave lengths to ones more favorable, but it most assuredly will point the immediate need of modern and equitable legislation to congress, in whose hands now three different Radio law amendment bills are pending.

Many well-informed leaders and observers of the situation feel that the decision can be interpreted as a "brick" cast at Secretary of Commerce Herbert Hoover's management of the broadcasting privilege. Advocates of an independent government commission of communications, with power to regulate Radio, and

## COVER GIRL LIVES IN CITY OF ROSES

PORTLAND, Oregon, is famous as the "City of Roses." The parkways and lawns are radiant with America's most glorious flower. And perhaps that is why Miss Gladys Johnson, the young lady on the Radio Digest cover, finds it so congenial to make her home there.

She is a staff artist at KGW, the Oregonian broadcasting station, and may be heard daily over the air as soloist and in the ensembles. Besides being an accomplished musician, Miss Johnson has starred in several motion picture plays and is quite well-known in vaudeville and symphony concerts.

## SENATOR BORAH GIVES RADIO BILL TO SENATE

Total Now Three for Legislators  
to Consider

WASHINGTON, D. C.—Senator Borah, of Idaho, has introduced an entirely new Radio bill in the upper house, which provides for the appointment of a national Radio commission which would take the entire administration out of the hands of the department of commerce.

He goes into the minutest detail as to what the commission is to do, and provides for the appointment of three members by the president of the United States at a salary of \$10,000 a year. The bill has been referred to the senate committee on interstate commerce, where the Dill and White Radio bills are now pending. The introduction of this bill is rather an indication that no action will be taken at the present session of congress on Radio administration.

## Farthest North Broadcaster Is Found at Bethel, Alaska

SEATTLE, Wash.—The farthest north broadcasting station is being operated at Bethel on the Kuskokwim river, Alaska. Paul Bestle, the owner, gives news bulletins on the air twice a week. A low power is used, but this will be increased soon according to plans.

# CONTENTS

Radio Digest, Illustrated, Volume XVII, Number 4, published Chicago, Illinois, May 1, 1928. Published semi-monthly by Radio Digest Publishing Co. (Incorporated), 510 N. Dearborn Street, Chicago, Illinois. Subscription rates yearly: Three Dollars; Foreign Postage One Dollar additional; single copies Fifteen Cents. Entered as second class matter at the post office at Chicago, Illinois, under the Act of March 3, 1879. Title Reg. U. S. Patent Office and Dominion of Canada. Copyright 1928 by Radio Digest Publishing Co. All rights reserved.

All the Live News of Radio.....	1 to 10
Ellen Rose Dickey, of WLS, Spreads Cheer for June Brides.....	6
KXTR is "High-brow" and Proud of It.....	7
"Big Rabbit" Love Leads a Romantic Trail Through Florida Jungles, Second Installment, by Hugh Fullerton.....	8
Solution of "A Step On the Stairs," Radio Digest Prize Mystery Story, by Robert J. Casey.....	11
An Evening at Home with the Listener In: A Chart in Central Time, showing when to listen in for stations.....	12
Let's Bury the Demon Statio, Dr. Guyer's Discovery, by Milo Gurney.....	13
Editorials, Inl-Gest and Condensed by Diectric.....	14
Women's Page: Index to Women's Programs.....	15
Advance Programs.....	16 to 27
The Super-Torodyne, An Improved 8-Tube Super, Part IV—Completed Wiring and Operation, by Prof. J. E. Owen.....	29
Directory of Radiophone Broadcastinging Stations, Part I, (Revised).....	31

## Looking Ahead

"Mrs. Polybank's Medal," is an Epic of a Mother's Heroism in the far North. A splash, the baby's face disappeared beneath the waves of the freezing water. But Mrs. Polybank was calm. While the others were stunned with horror, she stepped over the rail, fully dressed. It's in that big Mid-May Radio Digest, out Friday May 14, and it's a true story with a Radio ending.

Smitty's Ether Busters, Mickey Russell and the Ironing Club stand out as unique features in Port Huron's popular station, WAFD. Port Huron is right on the knuckle of the thumb of the big mitten peninsula. These broadcasters have their own ideas of entertaining Radio listeners. See the next Radio Digest.

It Started With a Special Program by the American Legion in Oklahoma City over KFJF. Ex-service men for hundreds of miles around, their friends and relatives sent in an avalanche of applause letters. And out of that grew the American Legion Radio Post No. 300. See story and pictures in Radio Digest, out May 14.

Hugh Fullerton Never Did a Better Thing Than "Big Rabbit," for which Radio Digest has the exclusive serial rights. With this issue you behold the unhappy Roberta whisked away from her Atlanta home. Wen and Dick are in hot pursuit, but will they find her? The next installment will enthrall you.

Spring Cleaning, How to Get the Most Out of Your Receiver, is the subject of a new series which starts with antennas and how to install them. This series is written exclusively for the man "who doesn't know it all."

Underground and Horizontal Antennae Series has the experimenters on their toes. Send in your name, if you want to help. A new bag of tricks will be given in the second article.

## Newsstands Don't Always Have One Left

WHEN YOU WANT

# Radio Digest

YOU WANT IT!

BE SURE OF YOUR REGULAR COPY  
BY SUBSCRIBING NOW

## SEND IN THE BLANK TODAY

Publisher Radio Digest,  
510 N. Dearborn St.,  
Chicago, Illinois.

Please find enclosed check M. O. for Three Dollars (Four, Foreign) for One Year's Subscription to Radio Digest, Illustrated.

Name.....

Address.....

City..... State.....

## GOLD CUP STANDING DIVULGES LEADERS

GIVES NAMES OF SIXTEEN  
ANNOUNCERS NEAR TOP

Interest High in 1926 Radio Digest  
Gold Cup Award—Twenty-Three  
New Candidates

They're off! The barrier is up and the 140 entries have swung into the race that holds as stakes the third annual Gold Cup Award and the title of the World's Most Popular Announcer. The race got off to a good start with the entries well bunched and their riders evidently jockeying for positions that will bring them safely around the first turn and well out in front.

Anyway, this is what is causing all the excitement. Here is the first hint at the relative standings of the announcers entered in the Radio Digest contest to decide by a direct fan vote who is the most popular Radio announcer. From inquiries received, the supporters of their favorite announcers are anxious to know how their candidates are getting along in the contest.

Although the deluge of votes has kept the Gold Cup Award Editor from twiddling his thumbs during the past several weeks, the number of votes received is small in comparison to the ballot that will be cast. So the standing given this issue cannot be indicative of the finish. Most of the fans are saving their ballots for the bonus votes granted when a group is turned in at one time.

#### Sixteen Leaders

This issue the sixteen announcers who have the largest number of votes have been arranged in four groups to prevent any one from being influenced to vote for the leader. Here they are:

First group: Pat Barnes, WHT; Norman Brokenshire, WJZ; Earl E. May, KMA; Hired Hand, WBAP.

Second group: Robert W. Griffin, WHO; Henry Field, KFNF; G. C. Arnoux, KTHS; Clyde Randall, WSMB.

Third group: Phillips Carlin, WEAF; Milton Cross, WJZ; Jerry Sullivan, WQJ; E. L. Tyson, WJW.

Fourth group: Lambdin Kay, WSB; Louis John Johnen, WLW; Leslie Joy, WEAF; Edward B. Husing, WRC.

But then you never can tell. Who knows? Next issue there may be some new names in the list of the first sixteen and, incidentally, some of this issue's leaders deposed. A great many things can happen when people start to vote. And just now they are voting quite recklessly for their favorite announcers.

#### New Names Swell List

Last issue there were 117 announcers entered in the contest for the Gold Cup, but still they come. Since that time, twenty-three more announcers have each impressed listeners as being the greatest announcer in the world. Of course, they can't all be the greatest announcer. But there is going to be one announcer gain that title at the end of the contest. He may be one of the 117 previously nominated, one of this issue's list, or he may not yet be nominated. If your favorite announcer has been nominated, get behind him and help bring him one of the highest honors in Radio. If he has not yet been named, name him and boost for him. The twenty-three new candidates, whose nominations were received since last issue are as follows:

- |                          |                           |
|--------------------------|---------------------------|
| Atkinson, Wm. L., WCAO   | Echenstein, Rev. H., KFUD |
| Church, A. B., KLDL      | Hughes, Jim, KDKA         |
| Connelly, "Doc", WRRD    | Merrison, Clair, KPO      |
| Darling, G. Walker, WJCF | Neelone, E. W., WQAN      |
| Dolan, Curtis, KPTR      | "Night Watchman", KGO     |
| Lades, Arthur F., WJLT   | WARD                      |
| Gaylord, Chester, WTAG   | Pierre, Jennings, KTC     |
| Greene, Paul, WSAI       | Ross, Geo. F., WRC        |
| Hall, Robert, WKAP       | Snowler, Roy, WJLF        |
| Hunt, Louis, WJAF        | Thomson, John, WRR        |
| Holby, Capt. Jack, WOS   | Williams, Rob., WVIC      |
| Hoskins, John, KPFR      | Wilmington, Arthur, KYW   |

#### How to Win Cup for Your Choice

Don't miss a single ballot, for when these are turned in to Radio Digest in a group of consecutive numbers, extra bonus votes are allowed the candidate voted for.

The ballots, top of this page, numbered consecutively, will appear in each issue of the Radio Digest until the close of the contest.

Each of these ballots will count for one vote when sent in separately. You can hold these ballots until you have four that are consecutively numbered and when they are sent in, a bonus of eight votes will be granted.

The larger the number of consecutive ballots submitted, the greater is the bonus allowed. Eight consecutive ballots receive a bonus of twenty votes. Twelve consecutive ballots receive a bonus of thirty votes, or a total of forty-two votes. And for a complete series of ballots, including one from each issue from March 27 to September 1, a bonus of fifty votes will be allowed.

# TO GREET ROTARIANS OF WORLD

## 2XBR, PORTABLE, TO TOUR AROUND GLOBE

PRIZE FOR AMATEUR WHO HAS BEST LOG OF TRIP

Motor Transmitter, "Betty Warner," Will Start May 4 from Hollywood on Trip Over World

LOS ANGELES—When the "Betty Warner," 250-watt mobile broadcasting station of Warner Brothers motion picture studios, sticks its nose out onto the broad level highway that leads from Hollywood to San Francisco on May 4, there will have begun the first lap of a very remarkable trip the itinerary of which will not only include the United States but foreign countries as well. 6XBR is the official call of this short wave portable station, but it will be known as the Betty Warner, so christened because the birthday of the daughter of Harry Warner, president of the motion picture producing firm of Warner Brothers, comes on the day when the start of the trip will be made.

The trip of the Betty Warner in the United States is with the full sanction and cooperation of the department of commerce. The present itinerary includes the following cities: Santa Barbara, San Francisco, Oakland, Portland, Seattle, Spokane, Walla Walla, Boise, Salt Lake, Denver, Hastings, Lincoln, Omaha, Kansas City, Decatur, Chicago, Indianapolis, Columbus (Ohio), Cleveland, Youngstown, Pittsburgh, Washington, Philadelphia and New York.

### Thence to Europe and Orient

At the conclusion of the American tour the station will be shipped overseas, and if suitable arrangements can be made with the Radio governing bodies of England, Germany, France, Spain and Italy, 6XBR will make tests in those countries, thence to the Orient, Australia, the Philippines, Hawaiian Islands and back home to Hollywood.

6XBR, probably one of the best equipped portable short wave stations in the world, will carry three men on this tour. The station itself is mounted on a motor coach chassis, is of 250-watt power and can be set up to broadcast on its assigned wave length of 103 meters in exactly 20 minutes. A description of the set appeared in Radio Digest a short time back.

### Amateurs to Aid Tour

The movement of 6XBR, through the cooperation of the American Radio Relay League, will be governed entirely by Frank Murphey, chief electrical engineer of Warner Brothers, who will remain at Hollywood. Each night from 11 to 11:30 p. m. Pacific time, a report will be forwarded to Mr. Murphey by the operators on the coach using a 40-meter wave length. Instructions will in turn be given by Murphey on the same wave length, which, of course, will be in the regular Continental code. The latter will be transmitted between 11:30 p. m. and 12 midnight Pacific time, each night.

To stimulate interest in the tour of 6XBR, Warner Brothers have announced a contest in connection with the trip and an award of \$1,000, open to all amateurs, will be presented to the operator who furnishes the most complete and accurate log of conversations between 6XBR and Mr. Murphey at KFWB during the international jaunt.

## Couzens Advocates One Communications Body

Michigan Senator Criticizes White Bill Commission

WASHINGTON, D. C.—The creation of a commission on communications, which would take over the regulation of Radio, telephones and telegraph, is sought in a bill which will be introduced in the near future by Senator James Couzens, of Michigan.

Senator Couzens does not believe that the secretary of commerce or any other one man should have control of the regulation of broadcasting. He thinks that ultimately a communications commission will be necessary, and he is in favor of its immediate creation.

"I am not in favor of the commission proposed in the White bill," said the Michigan senator. "I think it is a makeshift proposition. Nor do I favor placing Radio with the interstate commerce commission. That body already has its hands full with the railroads."

## HOT DOG! THAT'S A MEAN NUMBER



With one fuzzy ear cocked for jazz, Bekood wags an enthusiastic applause if the syncopation suits her canine fancy. WLS claims this winner of a blue ribbon at the last Chicago dog show as its youngest fan. Next to listening to broadcast jazz music, Bekood, who is nine months old, enjoys telephoning and can recognize the voice of her playmate, little June Ducker of Oak Park, Ill. Radio seems to fascinate the wire-haired fox terrier.

## Six Lines Carry Telephone Requests to Station KFOA

SEATTLE, Wash.—A probable solution to the handling of numbers of request and thank you calls is announced by Station KFOA here. A special six-line telephone switchboard has been installed in the station. With this new equipment the station will be fitted to handle city requests with speed and dispatch at the rate of about 400 per hour.

## Legion Broadcasts War Songs

SHREVEPORT, La.—Military music popular during the world war, played by the Shrine band of El Karubah Temple, El Karubah fire and drum corps, quartet and other music, will feature the Louisiana Department Legion program to be broadcast from Station KWKH, here, May 6, 8:00 to 10:00 p. m. Central time. A feature of the program will be the rendition of any of the old war tunes requested by veterans.

## Five Musicians to Four Homes

CINCINNATI.—Mentor, Kentucky, a town with a population of only 100 people and twenty residences, challenges any other town to produce more musicians, in proportion to population. This challenge was broadcast after a band of twenty-five children came down the Ohio river in a boat and put on a program from WKRC, here, that brought hundreds of letters and telegrams. The average is five children who are musicians to every four residences.

## Sure! And It's Good

RADIO DIGEST breaks all records in the big Mid-May special, out Friday, May 14, which has been under preparation for several weeks. Station features, fiction, authentic inside Radio news, technical features and pictures galore.

You'll get a thrill out of "Mrs. Pollyblank's Medal," true story of the far north, a mother's heroism in rescuing her drowning babe from icy waters and how she was rewarded. Little "Mike Alpin" will broadcast a thing or two you never heard before. Ever hear of the Wolverine "Ether Busters"? Wild horse and broncs "ain't in it."

The technical editor takes off his coat, rolls up his sleeves and tells the tinkering set owner how to spring houseclean.

The \$500 in awards to the lucky sleuths who doped out the last chapter to "A Step On The Stairs," will be announced.

And don't fail to read the next installment of Hugh Fullerton's romance, "Big Rabbit." You'll cross your fingers every time you see cotton tail.

Remember, the big Mid-May special—ON ALL NEWS STANDS MAY 14.

## KTAB AND KOA BOTH TO BLANKET SPHERE

STATIONS BLAZE WAY FOR ROTARY CONVENTION

150,000 Members Will Tune In—International Body Meets in June at Denver

Rotarians far and near, representing more than thirty-five countries, are destined to be serenaded by two broadcasting stations in globe-encircling trials May 21 and 26. The Radio greetings which will permeate the air are in preparation for the international convention of the Rotary organization which will be held early in June at Denver, Colo.

The May 21 program, to be radiated on 240 meters by KTAB, the Post Enquirer station at Oakland, Calif., will begin at 4 a. m. Pacific time. This is equivalent to 10 p. m. May 21 in Australia and New Zealand, and 7 a. m. May 20 in the Eastern time band of the United States. The KTAB program will be more in the nature of civic boosting and will call the attention of members of Rotary, Kiwanis and Lions clubs to the new \$10,000,000 harbor project at Oakland.

### 150,000 Members Will Listen

At Denver, however, KOA will devote the whole night of Wednesday, May 26, to a world girdling attempt in honor of the Rotary international convention to be held in the city in June.

Instructions to stand by already have been sent to 2,500 club organizations comprising 150,000 members living worldwide from Europe and South Africa to South America, Australia and the Orient. Serving as a backbone to this spectacular dusk-to-daybreak entertainment will be music, including patriotic airs of all nations, to be furnished by the best artists available.

A big feature, it was expected, will be messages of greeting to broadcast listeners from ambassadors and high statesmen representing the principal countries to which the mile-high Rocky mountain station will transmit.

### Greetings in Native Tongues

As a means of stimulating additional interest among ethereal enthusiasts, these microphone greetings will be given in the native tongue of the country represented.

Special broadcasts have been planned also for Rotarians at sea, who will be en route to America from all parts of the globe to attend the international convention of the organization, to be held in Denver early in June.

KOA's world blanketing attempt will be launched promptly at 8 p. m. Mountain Standard time, Wednesday evening, May 26, and will be continued without a break until 5 o'clock the next morning.

Records show that KOA without previously undertaking an all-night, long-distance broadcasting attempt, has already spanned both the Pacific and Atlantic oceans, having been heard in the state of Canterbury in New Zealand on the west and Birmingham, almost in the geographical center of England, on the east.

## BROADCAST CALL FOR MINISTER OVER WBZ

He Hears and Then Telegraphs His Acceptance

SPRINGFIELD, Mass.—What is believed to have been the first call ever extended by a church to a prospective pastor through the medium of Radio, was made recently over the WBZ microphone when the Chase Memorial Baptist church of Springfield, Mass., broadcast a call to the Rev. E. L. Washburn of Pennacook, New Hampshire.

The official board of the church met early in the evening and unanimously voted to call Mr. Washburn and at the same time they expressed the feeling that the call should be made immediately. The aid of Station WBZ, Westinghouse, New England station, was sought and as a result, within less than an hour after the board had passed their vote, the call was broadcast.

Mr. Washburn heard the call and telegraphed his acceptance the same evening.

## KTNT Puts up New Towers

MUSCATINE, Iowa.—Two galvanized steel towers are being erected at Callia-phone studio KTNT, here. The towers will be erected with a number of colored flood lights about them to flood them at night.

# Their Voices Thrill Millions



These are some of the faces of the players who have thrilled millions in the United States, Mexico, Canada and even more distant points in their presentation of the Radio Digest mystery play, "A Step On the Stairs." Jean Sargent (left) as "Mary Williams," WNAC, Boston, and Bernice Berwin (right), KGO, Oakland, Calif. Top, center, is Wm. M. Sweets, WRC, Washington, D. C.

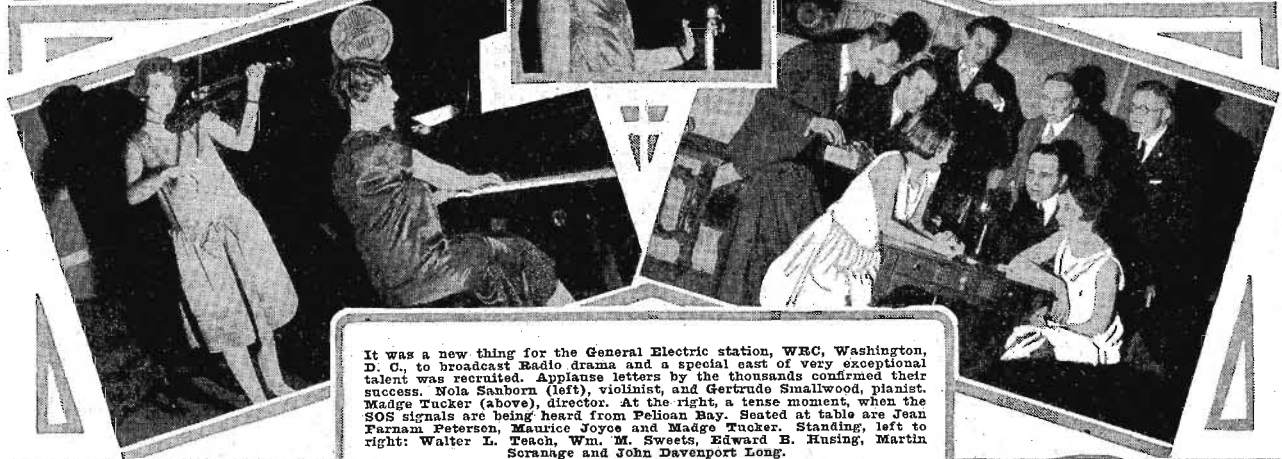

It was a new thing for the General Electric station, WRC, Washington, D. C., to broadcast Radio drama and a special cast of very exceptional talent was recruited. Applause letters by the thousands confirmed their success. Nola Sanborn (left), violinist, and Gertrude Smallwood, pianist, Madge Tucker (above), director. At the right, a tense moment, when the SOS signals are being heard from Pelican Bay. Seated at table are Jean Farnam Peterson, Maurice Joyce and Madge Tucker. Standing, left to right: Walter L. Teach, Wm. M. Sweets, Edward B. Husing, Martin Soranage and John Davenport Long.



On the other hand, the General Electric station, WGY, at Schenectady, N. Y., has been broadcasting Radio drama almost from the time of its first season on the air and in the lower panel are some of the well-known WGY players. Left to right: Dorothy Vrooman (Aunt Helen), Marietta E. LeTarte (Mary Williams), Ton Byck Clay, director (Frederick Ardwyn), Wilbur Cook (Graves), Frank Oliver (Tolliver), and George Markham (Cousin William). Mr. Clay (center) and Miss LaTarte (right). WGY is heard overseas.



# A Dead Man's Guests in Play



In the Chicago metropolitan area of approximately 5,000,000 "A Step On the Stairs" was presented by the WMAQ Players of the Chicago Daily News. William Ziegler Nourse, playing "Tolliver," had stepped out of the picture as the above scene was flashed. The others are (from left side of table) Robert Graceland (Henry Graves), David A. Watts (John Barton), Viola Roth (Aunt Helen), Ben Adams (Harl Singh), Florence Bayer (Hazel Stanton), Gloria Chandler (Mary Williams), and Wm. C. Boyden, Jr., (Ardwyn). Mr. Boyden portrait at left and Mr. Nourse at right.



The WOC Players, Davenport, Iowa, were directed by Chas. H. Walsh (above) who took the part of "Lawyer Ardwyn."



William Ziegler Nourse (above) introduced Radio drama to WMAQ, Chicago, nearly two years ago and has gained a large audience for the WMAQ Players. Mace Blynn (below) is one of the stars of the WOR Players for the great New York City area.



Few stations have been favored with a real Hindu to play the part of Harl Singh. At WHO, Des Moines, this character was played by Surendra Mitra of Calcutta, graduate of Iowa State university and well-trained dramatic artist. Other members of the cast in the picture are Katherine Atkins (Mary Williams), Myron Thompson (Tolliver), Wallace Van Ooster (Jones), Arliss J. Martin (Graves), and Margaret Orobough (Aunt Helen). Bobby Griffin, assistant announcer at WHO, directs the players.



Lower panel shows WOR Players, Newark. (Detailed story here next week.) Portrait: left, Evelyn Lewis (Mary Williams); right, Gertrude Kearney (Aunt Helen). Scene: Miss Kearney, Miss Lewis, Vinton Haworth, Mace Blynn, H. Gordon and Bruce Conning, director.

# Here's Cheer for June Brides



"Now stir in three eggs," says Ellen Rose (above), talking into the microphone as she advises and works with brides in her kitchen studio.

By HAROLD P. BROWN

**M**AY—the first month of the bridal season!

These are the busy and the exciting days for the anxious brides-to-be. There are trousseaus to be made and new home furnishings to be considered. In the offices of the big cities, in the homes—city and country—Betty is getting ready for the big event of her life. Mother is worried and dad is melancholy—daughter, the sunshine of the house, is going away to a new nest.

After the great day, the farewells, the bridal trip and then the advent into the new home—and home duties!

Ah! There's the rub—

What will Betty do then, poor thing, if she hasn't had much experience at baking biscuits, bread, cakes, pies, cooking meats and vegetables?

Well, it won't be as hard as it was when mother was a bride.

Betty will have the advice of some of the most expert home makers in the country right in her parlor every day—blind and deaf, perhaps, but not dumb! No prying eyes, no embarrassing questions, just straight talk on what to make and how to make it—right from the Radio receiving set.

**P**ROBABLY one of the best known women to advise housewives over the air is Ellen Rose Dickey of the Sears-Roebuck station, WLS, Chicago. "Ellen Rose," is the name by which she is best known to her listeners. She is a real housewife and a mother, not a mere theorist. She makes and bakes what she preaches and has the resources to make sure she is right before going ahead and broadcasting.

Her "Homemaker's Hour" begins at 9:15 in the morning. Her studio is a well ordered kitchen in the Sears-Roebuck plant where the flour, eggs, milk, seasoning and other ingredients are often stirred, rolled and patted as she turns to the microphone and chats neighborly about it to Mrs. Annabelle Peters of Jasperville, Maine; Mrs. Marion Carter of Boxwood, Virginia; Mrs. Mabel Field of Hastings, Michigan; Mrs. Irving Hill of Tacoma, Washington; Mrs. Catherine Dwyer of Sunmount, New Mexico and a million or so others who tune in for the "Homemakers Hour" at their homes in the areas between those points.

"People sometimes ask me," said Mrs. Dickey to her interviewer, "how a busy housewife can take time out of her early work to listen to a Radio talk at 9:15 in the morning. But it is very apparent that she does. Many not only listen but they make notes and take down the details—especially young brides just learning how to cook and the more experienced housewives who want to find

## DON'T Worry About Burning the Biscuits, Ellen Rose Dickey Will Tell Newlyweds All About Making Pies, Cakes, 'Neverything Over WLS, Chicago

new ways of doing things that they have been doing for years. The thousands of letters prove that they do.

"ONE morning I asked the members of our circle if someone would send me a good recipe for hassenfeffer or any other way for cooking rabbit.

"The deluge of recipes for cooking rabbit almost swamped me. It was simply astounding. I picked out the best of them and made up a special bulletin for cooking rabbit. But the prize contribution came one day in a big bulky package—a poor little bunny all skinned and dressed and ready to be made into hassenfeffer."

During the sausage season she presented her circle of listeners with her favorite sausage recipe. A very, very good recipe, she thought. But regardless of her own opinion there were a thousand or more other women who possessed equally prized recipes and one and all sent them to her, some with samples to match.

So, never you mind, Betty dear, when it comes around time to be thinking of that first dinner—what to do and how to do it. Just dial in 344.6 meters at 9:15 in the morning and Ellen Rose will help you. And if there is anything special you want to know that she doesn't happen to mention, drop her a line in care of Radio Station WLS, Chicago, and she'll either answer you over the air or by mail. It won't be as hard with the Radio as it was when your mother was a girl.

For fifteen years Mrs. Dickey was a "home woman," keeping the hearth for her husband and son, and when circumstances forced her into the business world she capitalized on her knowledge of kitchens and children.

When she talks to the farmer's wives she knows her listeners and their problems from her own personal experiences. Her childhood was spent near Saginaw, Michigan, where her father owned and operated fourteen farms. It was her chief delight to join her father on his trips to these farms where she visited in the homes and was invariably treated to the goodies that the motherly housewives had on their pantry shelves. Many of these families are today her most ardent listeners and she receives frequent invitations to "come for a visit and stay as long as you can."



Lovely pies and exquisite dainties are received by Ellen Rose (left) from the listeners in her Homemaker's Circle. Mrs. Henry Bendeavagh (below) of Lemont, Ill. is typical of thousands who are members of this circle conducted by Mrs. Dickey.

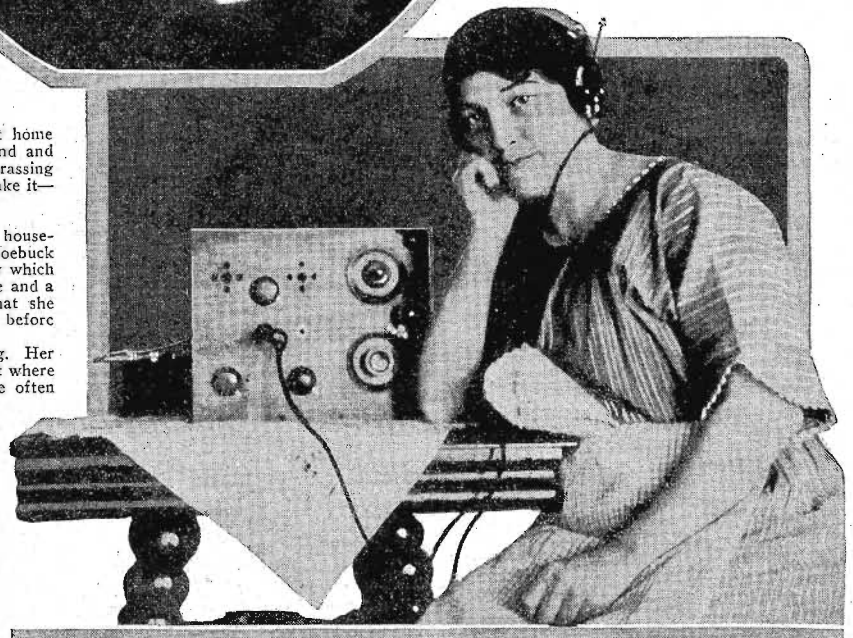

# "High-brow," and Proud of It

**K. M. TURNER, Discoverer of Hollow Carbon Granule for Hearing Devices for Deaf, Applies Invention to Modern Microphone with Surprising Results. Builds Radio Station KMTR and Presents Select Classical Programs.**

By G. L. KING

**T**HE afternoon heat of an August day, combining with the steam of the Seine, had wrapped a stifling blanket around the little town of Vincennes, France, driving the shop-keeper back into the cool recesses of his store and the housewife out into the cobbled courtyard where the house cast a shadow that at least gave the impression of coolness.

Apart from the town and near the bank of the stream itself stood an unpainted frame shack, an oddity in a town of stone buildings, in which a middle-aged man, collar off and in shirt sleeves, toiled on slowly in spite of the heat and humidity, too deeply enthralled by the fascination of his work to heed the glaring sun outside and the almost unbearable temperature inside the small room. In one corner stood a small electric furnace and the various workshop apparatus of the scientist were scattered about on benches in apparent disorderly array.

The middle-aged man moved even more slowly at his work. Finally, with a glance at the clock, he stepped over and turned

off the electric furnace, the absence of whose hiss and sputter seeming only to accentuate the heat of the day. Then an impatient wait until the furnace could be opened and the tiny brick of material taken out. The crust was carefully broken in the center of which was a tablespoon of black pellets, not synthetic diamonds which are usually associated with electric furnaces, each about the size of an ordinary pinhead. These he placed very carefully on a piece of white paper, selecting a half dozen or so to put on a slide under a powerful microscope. The examination under the microscope took only a minute.

**T**HEN the man sat down heavily in the only chair in the place, tilting it back to get an approach to the comfortable angle of the American rocking chair, and rested as only body and mind can rest after a big task is finished. All the afternoon he sat there as the sun slowly crept down to the horizon and the first cool breath of evening came, impervious to the changing temperature, his surroundings, hunger or time, dreaming on and crushing those tiny pills of carbon that had just come from the furnace between thumb and forefinger.

The rather heavy set man was K. M. Turner and on that hot August day in France Radio broadcasting, as we have it today, was made possible. The little black pellets that the furnace had turned out were hollow carbon granules, without which nearly every broadcast station today would be useless, for the carbon pellets are the very heart of the carbon-type microphone so universally used.

But K. M. Turner's thoughts that day did not include the wonder of Radio broadcasting. His interest at that time was in discovering some means to aid the deaf, and the hollow carbon granules meant that the last of his work was done. Upon his return to America the General Acousticon company was formed to manufacture and sell those instruments that have meant so much to the deaf and near deaf, the acousticon. When next you see one of those triangular shaped, flat backed cases upon a person's coat, think of it as a miniature Radio station and the real father of Radio as it is today.

Not only did the discovery of the hollow carbon granule mean a Godsend to the deaf, but the development of the dictograph followed, which has since so spectacularly played its part in crime detection and prevention. Nor did it stop there for the development has gone on and on through a variety of devices, each one of which has meant an additional service to humanity in some form or other. (Continued on page 13)

"Dad" Carlton King, (left), former motion picture actor and producer, mans the mike at KMTR and supervises the station in general. Below is Loren Powell (left) and his famous KMTR orchestra composed of picked men from Los Angeles Philharmonic orchestra. They are on the air nightly.



At the top is K. M. Turner, whose careful research made possible the finest sensibility of modern microphone, also head of Turner Radio Corporation. It was Mr. Turner's idea to make KMTR distinctive as "high brow."



But KMTR is not too ethereal to afford an hour for the children as may be seen in the above picture. This particular feature is conducted by Miss Georgia Simmons who formerly conducted the Wren's Nest at Atlanta. Above, at the left, is Miss Simmons in negro mammy make-up telling Uncle Remus stories. The other picture shows her as she is. The children in the studio with Miss Simmons help her to present the Children's Hour in a natural and realistic manner.

# BIG RABBIT & by HUGH FULLERTON

A MONTH had passed without pay checks when the financier supposed to be backing the new Atlanta daily called all bets off and said he was through. Wen Lindsay and Dick Borton, imported for heavy reportorial duties and to give the sheet New York style, found themselves broke and jobless.

"But why worry? Never trouble trouble till trouble troubles you," counseled the alert and optimistic Borton with one of his characteristic grins. "Something always turns up for the wide-awake newspaper man."

No sooner spoken than done. The secretary of one of the leading bankers knocked at the door and announced that his employer would like an interview with Lindsay. The interview ended, with \$1,000 advance expense money, jobs for both Lindsay and Borton and an assignment to locate Colonel Gaskill, a leading citizen, supposed to be laid up with gout. Lindsay called at the colonel's home where he met Roberta Lee Tomnesson, the colonel's ward and with whose fortune the old warrior had been gambling. He also had the opportunity of furthering an acquaintance that began with love at first sight, when he had rescued the girl's dog from beneath a passing automobile. Roberta told him the colonel was mysteriously absent and that she feared a negro servant by the name of Trimble, believed also to wield a strange power over Colonel Gaskill. She promised to send him a note if further developments threatened her safety.

With a heart yearning for the girl and fists itching to smash Trimble he left the house and returned to his chum, Dick Borton.

## CHAPTER IV

### The Battle in the Steeper

BORTON lay sprawled over his bed when I returned to our room, a pile of books on the floor, and half a dozen of them scattered across the room as if he had thrown them. He glanced up as I burst into the room and grinned.

"Did it make a bit with the fair dame?" he inquired lightly.

"It?" I questioned, rather puzzled.

"Yes, the tie," he responded, "it is one few girls are able to resist. I hope she liked it. Is she beautiful, superb, matchless, like all the others of yours have been—for two weeks?"

"Shut up," I fared angrily. "What are you doing? Wasting all this time?"

"Just now," he answered slowly and with his most tantalizing grin. "I am reading up on the negroes of America, their origin, habits, superstitions, and especially trying to trace the tribes from which negroes in certain sections of the South were stolen. How did you make out?"

As briefly as possible I told him everything that had transpired. To my relief he became serious at once.

"It looks worse and worse," he remarked quietly. "I thought as soon as I saw that fresh nigger that it was serious."

"You managed to see him then?"

"Yes, I bought a lot of vegetables, meats and fruit, borrowed a market basket and went to the back door to start an argument with the old negro woman who cooks. I insisted on delivering the things and she said she did the marketing herself and had not ordered them. I kept disputing with her until Trimble came to see what was the matter."

"I heard him go. It helped us talk," I interjected.

"I opened up on him just to draw him out, and he certainly is breeding trouble for himself. The old woman is scared to death of him and made hoodoo marks on the floor while he was talking. Trimble had me puzzled so much so that I went to the library and held up the librarian for all these books."

"Didn't he strike you as an odd type?"

"Yes, both in looks and in actions. He holds himself better than the other negroes, and equal or superior to the whites."

"I THOUGHT I knew the southern negro," said Borton earnestly, "but this one is a new kind to me. He isn't Kaffir; he isn't Guinea; he isn't Hottentot. His ancestors came from one

of the central African tribes. Some of them must have crossed either with the Creeks or with the Seminole Indians. He hasn't a drop of white blood in him.

"You see," he went on rapidly, "the negroes caught by the slave hunters were from the const tribes, mainly, later from the tribes further inland. If the cargo was all from one ship, the chances were they would be sold in one district, so they intermarried and retained many of the tribal peculiarities. You will find a lot of plantations where the owners did not believe in selling their slaves, where the peculiarities of accent, the skin tones, and the traditions still survive. This Trimble is uncommon. I can't quite figure his breeding."

"He calls himself King Solomon and acts as if he thought he was of royal blood," I observed.

"That is common enough," laughed Borton. "Many good looking negro men set up the claim that they descend from African kings, and they often pretend to chieftainship. This one may be the genuine article. He has an unusual bearing. By the way, did you notice any rabbit marks?"

"Rabbit marks?" I asked, starting with surprise. "No—not about the negro; but I saw rabbits everywhere in the Major's house."

"Where? What were they?" demanded Borton, oddly agitated, and leaning forward eagerly.

"I noticed the Major's note paper had a rabbit printed on it, the andirons in the fireplace were rabbits, and the book mark had a rabbit embroidered on it. Besides there is a rabbit's foot, a great big one, in a case on the major's writing table. I thought it was a funny idea."

"I should say it is funny," snorted Borton. "You idiot, didn't you ask the girl about it?"

"What the deuce are you driving at?" I fired back angrily. "Think I pay attention to every fool superstition? It's

probably some whim of the Major's like the rabbit foot bringing luck."

"OH LORDY! What's the use?" groaned Borton. "You fellows who never had to live among them think negroes are simple, harmless jokes. Understand this; the rabbit's foot means something to a negro who remembers the traditions of his African forefathers. This affair looks worse the more we go into it. And you were so confoundedly upset by the sight of a pretty girl—O well, what's the use? Let's get down to the Piedmont, get some dinner, and see what we can learn about Gaskill."

We both were rather irritated, but, following our long-established custom, we avoided discussion as we went to dinner. We learned little except that Major Gaskill was a hard drinker at times, and a lavish spender of money when in funds. It was nine o'clock when we returned to our rooms. The landlady was waiting for us with a note.

"Old darkey woman left it," she said, "about half an hour ago. She said it was important."

I tore open the note hastily, recognizing the writing I had seen for the first time that afternoon.

"They are taking me away tonight," the message ran. "Trimble found one of the notes we dropped in the library. I heard him and Tillie, my maid, planning to take me somewhere. Please try to stop them. Don't call the police but come quickly. They spoke of taking me south. They do not know I overheard, so mammy Hannah will bring this. Please come quickly."

The signature was a scrawled monogram. Before Borton had time to read the note I was imploring him to hurry, raging at the carelessness we had shown in not being at hand when Mammy Hannah arrived with the summons. The blow had fallen not only unexpectedly

but much quicker than we had anticipated.

"Call a taxi," directed Borton, who was preparing for action with quiet haste. "Take fifty or sixty dollars in small bills off that roll of yours and conceal the rest somewhere in your clothes. Keep cool. With you in a second."

He was getting ready as quickly as he would have done if summoned to cover a big newspaper story. I could not help admiring his calm manner, and it did much to help me to recover from my excitement.

"RING UP the house first," he ordered, while gathering a few clothes up in a small satchel. "See if they have started. Then get the station and learn train times."

I had already summoned a taxicab and, perspiring with excitement and anxiety, I called the Gaskill mansion time and again, urging the girl at the telephone to continue ringing. No reply came.

"They probably have started. Get the taxi office again."

"Hello," I said when the taxi office at the Piedmont replied to my second call. "Have you sent a cab to Major Gaskill's house?"

"Yes, started half an hour ago," came the quick unsuspecting reply.

"Come on Dick," I yelled. "Don't wait for the station call. They left less than half an hour ago. There's a bunch of trains that leave about ten o'clock. We'll catch them at the station."

Spurred by offers of higher pay, the taxi driver sent the car at reckless speed through the downtown district. He swung around the corner at the Maxwell and drew up at the edge of the tracks at the end of the station. We threw him a bill and together raced almost the length of the station.

"Reporters," we explained breathlessly.

"We must catch them," I said, handing him some money.

Borton already had passed through the gate and was sprinting along the tracks in pursuit of the slowly moving train. I followed at top speed. Luckily for us the railway tracks run at a grade for a few blocks compelling a slow rate of speed. Before the train had begun to gather speed for the dash through the tunnel out, Borton had swung onto the rear platform of the private car, and held out his hand. I leaped, he grasped me and after a moment's struggle my foot found a hold and an instant later we clung to the steps. Fearing to be brushed off from our precarious footholds we clambered around over the couplings; and a moment later we stood in the observation platform, panting, perspiring, wondering if our presence on the car had been observed. To escape being seen we stood at either side of the door leading into the car. By peering around cautiously we could see the reflection of light but the view of the interior of the car was cut off by a drawing room partition.

"NOTHING to do but go in," panted Borton after we had partially regained breath. He tried the door carefully. It was locked by a spring lock inside but the upper part of the glass portion was lowered and by reaching in Borton managed to shove it down. He pushed the catch and the door opened.

"Come on," he whispered, and led the way cautiously, advancing along the narrow corridor. At the turn we stopped. Toward the front end of the car we could see Trimble standing. With him were the Pullman conductor, the porter, and a brakeman. Evidently they were settling the matter of transportation, for the conductor had his back toward us and was checking the tickets. As he counted the slips of paper I heard him say, "Four."

"No good," whispered Borton, drawing his head behind the angle. "We'll have to hide somewhere until the trainmen get out. We can't get past Trimble. If we can reach the trainmen long enough to explain, they'll help us. If they catch us now, they'll take us for tramps and kick us off. Let's hide until the coast is clear."

Borton tried the door of a stateroom cautiously, but found it locked. The next one, fortunately, opened.

"They're not going to use this one," he whispered. "Hide under the berth. Luckily this is an old-style car and the berths are high enough to get under."

"I'll slip into another room and hide there. Take hold of the end of this



"We're in Jacksonville, Florida," he (Dick) announced. "And all my money is gone except what is sowed in the lining of my coat."



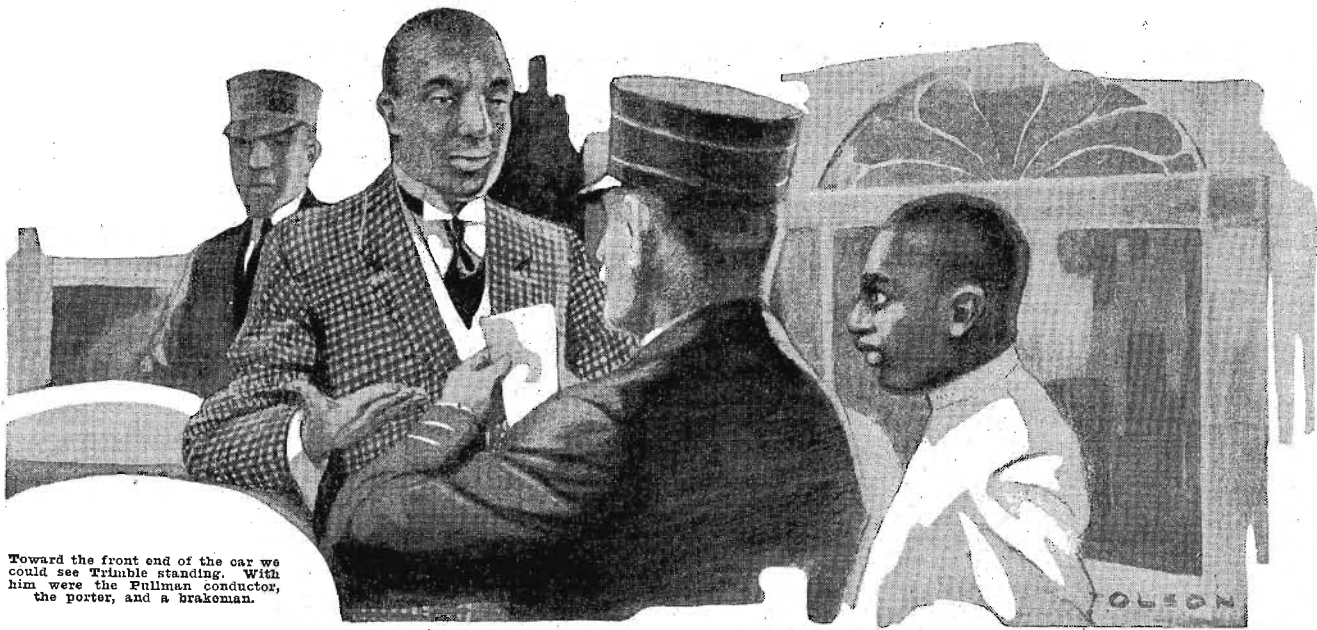

Toward the front end of the car we could see Trimbale standing. With him were the Fullman conductor, the porter, and a brakeman.

string. When I jerk it you come and come a jumping. I'll signal you as soon as the trainmen get out."

**T**HE door closed quickly and I felt the string tighten. Then, after a minute, it remained motionless and I knew Borton had found his hiding place without being detected. Looking around for a place to conceal myself I doubled up and backed under the berth, letting the folded blankets drop to conceal my hiding place. It seemed hours that I waited there in the darkness expecting the tug on the string. I was alert in every muscle, starting at every noise.

It was hard to restrain myself, and the thought of Miss Tomneson in the power of the insolent negro made me grit my teeth and curse under my breath. I vowed to exact personal vengeance. Once, I thought, I heard sounds in the car, rising above the rumble of the train, now tearing along at full speed. I could catch the murmur of voices once in a while which seemed that a sharp, imperious voice was giving orders, and a softer one, which must have been Trimbale's, was answering. My fears were relieved.

The remembrance of the fourth ticket confirmed my belief that Major Gaskill must also be on the train. I was just getting ready to crawl out and investigate for myself, when I tugged at the string, and instead of an answering pull, the string came toward me without resistance.

At that instant the door of the stateroom opened quickly. I could see a pair of feet, shod in patent leather with white spats, and I knew it was Trimbale. Not until that instant did I realize at what a disadvantage a man is placed when he hides under a berth. I tried to prepare for a spring, to take the negro unawares in case he discovered my presence, but scarcely could move.

"I thought I heard something in this room," said Trimbale.  
"No sah," responded the porter from the passageway. "Ah straightened up dat room mahself, jes befo' de train pull out. No one ain't in hyah."

"You said no one was in the other room, too," sneered Trimbale.

Like a flash I realized that Borton had been discovered. I struggled to get clear of the berth. Trimbale had half stooped to look under the berth, and my first movement revealed my presence. I made a desperate grab at his feet. One hand gripped his leg. I pulled myself clear, strove to seize both his legs to bring him to the floor, and had almost dragged myself to my knees when a terrific kick on the jaw rolled me, helpless and groggy, on the floor of the car.

"That's the other one," said Trimbale angrily to the porter. "How did he get in here? I'll fix this one."

My dazed brain was struggling to regain command of my paralyzed body. I felt a sharp sting in my arm. Dimly I realized that the negro was using a hypodermic needle. I fought blindly to reach him. Then a great weariness overcame me. My body seemed to die.

"That will fix him," I heard the negro say, his voice sounding from afar. He turned me over. A sharp exclamation of surprise broke from him, and a vicious kick that seemed to drive in my ribs

followed. The kick half awakened me from the lethargy that deadened my muscles.

"That one was at the house today," I heard him say angrily. "Nigger, am I?" he kicked me cruelly. "Trimbale, eh?" He kicked me again.

Then the rattle of the wheels on the fish plates sounded a lullaby and I sank into unconsciousness.

CHAPTER V

Seeking the Rabbit's Tracks

**W**HEN I regained my senses I was sitting bolt upright on a grassy embankment at the side of a railway track. Before me, more than a mile wide, stretched a magnificent river. A white, beautiful, ocean-going yacht—flying a strange pennant—rode at anchor at the turn of the river above. A long bridge, yellow and spidery, spanned the water and disappeared into the pine woods on the opposite shore.

A ferry boat was chugging its way across to a big amusement park. On one side as far as the eye could reach the curving shore was lined with magnificent houses, the lawns spreading down to the water's edge.

At many of the private docks launches and yachts were waiting. In the other direction a city of towering spires, tall hotels, and magnificent public buildings sloped gently back from the rows of docks along the river's edge. Beyond the city the river turned and widened into a great expanse, upon which large ocean liners and rust-red tramp steamers lay at anchor.

I glanced around, slowly striving to remember what had occurred. A few feet from me was Borton, stretched upon his back, unconscious, although I could have sworn his eternal grin was plastered on his handsome face. With an effort I rallied and crawled to where he was lying. I shook him; but the only effect was the quickening of his deep breathing.

I was weary and aching in every muscle. The places where the negro had kicked me pained until it was an effort for me to move. My head ached and my mouth seemed kiln-dried. I kept shaking and tugging at Borton, calling his name, and after what seemed a long time he opened his eyes. Then he sat up and looked around. Gradually the astonishment on his face gave way, and, looking at me, he grinned. It would have been laughable to anyone in a mood for laughter.

"Where are we?" he asked with the idiotic expression of a half-awakened man.

"I don't know," I responded weakly. "I sat and looked at each other foolishly, and finally, as if with an effort, he aroused himself."

"Let's get to the river and wash. The water will help," he suggested.

**W**E WERE so weak and sick that crawling down the ten-foot embankment to the water's edge was heart-breaking effort. Every muscle of my body protested; but finally we reached the water and plunged our hands and arms into the cool depths. It served to arouse our deadened faculties.

"Salt," commented Borton as he spat out some water. "We've reached the ocean somewhere. How did it happen?"

I told him my final experience, and the encounter with the negro.

"He got me quick," commented Borton, his chin setting with determination. "I left the door open in order to hear the trainmen go out. They quit talking and I stuck my head around the partition to see whether they had left the car. Trimbale was right on top of me. He kicked me and I went to sleep. He must have doped me too."

We made the best toilet possible, and feeling much revived, crawled back to the grassy spot to rest.

"We're a fine pair of detectives," said Borton with sarcastic emphasis.

"We are not," I agreed bitterly.  
"I wonder," asked Borton after a time, "whether we are good enough at this line of work to find out what city we are in?"

With an effort which left us almost exhausted we climbed up to the embankment, resting every few feet, and finally dragged ourselves onto a bridge over the railway, a bridge congested with traffic, which proved we were on one of the main trade arteries of the city.

"I'm not ordinarily inclined to curiosity," asserted Borton whimsically, "but really, I would like to know what city we are in."

"Ask someone," I suggested wearily.  
"Not for me," he replied, grinning painfully. "If I should the man would either think he was being kidded or that we were crazy. He'll either swing for the jaw or call the police. Wait a minute."

Inspired by a sudden idea he crossed the street, stopped at a news stand and examined the papers, returning slowly and somewhat disturbed in mind.

"We're in Jacksonville, Florida," he announced, frowning. "And all my money is gone excepting what is sewed in the lining of my coat. How is yours?"  
I made a hasty inventory and discovered with much relief that the bulk of the money Kincaid had given me was safe.

**M**INE'S all here, excepting some small bills I put in my trousers pocket. They overlooked the big roll."

"Let's get freshened up and plan the next step," suggested Borton. "At least we are nearer the scene of action than we were in Atlanta, even if we have lost the trail."

We signalled a street car and, in a few minutes, reached the business center of the district. We found a table on the balcony at the Seminoles. A pot of coffee, dripped to double strength, revived us and, while eating breakfast, we studied the strange adventures of the preceding twenty-four hours, and made plans for further pursuit of Trimbale and the missing girl. "It's a blind search now," said Borton, although from the set of his jaw it was plain he was less discouraged than I was. "We'll have to cast around to find the trail. The best clue we have is that car I found before going to sleep last night." He grinned as he said it. "It was a private car." Major Gaskill heard from Trimbale that there was danger of exposure, and the major

slipped to Atlanta, used his influence and got the car.

"I heard the conductor say it was the best that could be found at short notice. I'll trace the car. You go to the telegraph office and see if you can learn whether Trimbale or Gaskill did any telegraphing. After that go to the water front and find what boats have left. Ask for a boat for Major Gaskill, two girls, and two negro men abroad leaving early today."

"Two negro men?" I asked, surprised.  
"Of course. The porter never would dare go back to the job after what happened in his car. Either he is in hiding or has joined Trimbale and, I think, from the control Trimbale had over him, he is with them helping Trimbale."  
"Control?" I asked incredulously.  
"Yes. Else he would have raised an alarm. Trimbale put the conj on him."  
"Put the conj?" I repeated, puzzled.  
"Oh, you mean conjured him? You don't believe in that sort of thing really, do you Dick?"

**L**ISTEN, Wen," he said, leaning forward and speaking so earnestly I almost laughed aloud. "make up your mind not to laugh at that sort of thing. It may sound foolish to us but it is really serious. Just after I crawled into the stateroom Trimbale showed the porter something. If you ever heard a terrorized, overawed man it was that porter. He begged and whimpered and said he would obey the sign."  
"What sign?" I asked, impressed but stifling a desire to laugh at Borton's seeming belief in negro superstitions.

"I don't know, I wish I did. I only suspect." He seemed worried and anxious, lowered his voice almost to a whisper, glanced around the room, and, leaning over the table toward me, said:

"I think it was the sign of the rabbit."  
I laughed aloud. It was ludicrous; so trivial in view of the seriousness of our errand I could not help it. The idea of big, handsome Dick Borton, after years in the newspaper game, which is the surest dispeller of anything excepting realities, being overawed by a superstition was too much. In an instant I saw he was hurt and offended.

"Excuse me, Dick. I didn't mean to laugh, but it sounded so funny."  
"Funny?" he repeated, shoving his chair back in irritation. "Let's get to work. But if I'm not mistaken, before we get through with this case you will not laugh at rabbit signs."

Unappeased, he stalked stiffly out of the hotel and I limped away to perform my portion of the task. After a brief skitish around the telegraph office on Bay street, I encountered an old friend, a telegraph operator who had come South for his health and was working at central. I explained to him the seriousness of the situation and, after we had consulted with the superintendent, we violated the rules and I read the messages. Three had passed. One from Trimbale signed "King" to Major Gaskill warning him of danger. One from the Major to Trimbale, telling him to bring Miss Tomneson to a car that would be waiting; another saying "Ready tonight," signed by Gaskill.

(Continued on page 28)

**BROTHERS ARE YOUNG SCHOOL BOY ANNOUNCERS OF WDAF AND KFKU**



**KANSAS CITY, Mo.**—Of course, you've heard of the Patts. You know, Ralph (left) and John (right), the school boy announcers at Station WDAF and KFKU, or you're a stranger on the air lanes of the West. Ralph is assistant director and chief announcer at the Kansas City Star broadcaster and John is the assistant director and chief announcer at the Kansas University station. Nice young men, too, and their ages, instead of handicapping them, seem to add the vim, vigor and vitality of youth to the programs of the stations. But here is another distinction. Neither can sing, nor do they toot horns or test the patience of the mike in any way. Just think! Two announcers who know they can't sing, and don't try!

**PHOTOS LEAP OCEAN IN TWENTY MINUTES**

**POSSIBLE TO OPERATE ON COMMERCIAL BASIS**

Radio Corporation and British Marconi Company Cooperating in Development of Invention

**PLYMOUTH, Eng.**—If the expectations of Richard H. Ranger and the Radio Corporation of America are realized, photographs will be transmitted across the Atlantic ocean in twenty minutes time at a cost that will permit it to be done on a commercial basis. Mr. Ranger is an official of the Radio Corporation and is now in England installing the apparatus and equipment, and plans on transmitting photographs the early part of this month.

The British Marconi company are cooperating with the Radio Corporation in the development of the device, which, the inventor claims, transmits pictures five times faster than any method now in use, whether by wireless, Radio or cable. Due to the simplicity of its functioning, the device does not depend upon any artist or draftsman at either end. The reproductions are built up simultaneously by a special synchronizing device which completes the pictures as soon as the transmission is finished.

**For General Use**  
According to Mr. Ranger, it is planned to base the rates of transmission on a scale of fifty dollars for twelve square inches. Although it is probable that newspapers will be the largest purchasers of the service, the invention will undoubtedly prove valuable in the sending of signatures and other reproductions needed by private individuals or business organizations.

The invention is based on the reduction of "picture impulses" necessary for reproduction from about 20,000 per square inch to 4,000. This is the main factor in quintupling the speed, efficiency and economy, and making the transmission commercially practical.

The synchronizing mechanism is controlled by tuning forks and pendulums pick the light and dark of the picture, analyzes it in terms of impulses and then by an almost instantaneous process builds up the same impulses on the other side. Two recent trials between New York and London and Honolulu and San Francisco, were successful.

**AUSTRALIA? EASY! BUILD RYAN SUPER**

**H**EARD Australia yet? Now seems to be the time if you don't mind staying up late or awakening early to tune in. Another reader, F. Biggell, living at Regina, Sask., Canada, reports: "I have been hearing 3LO, Melbourne; 2BL, Sydney, and 4QG, Brisbane, Australia, nearly every morning for two weeks. The time I listen in is from 3 to 5:30 a. m. Mountain time. I heard 3LO announce on two occasions that a big celebration would take place on Returned Soldiers' Day, April 25, that the parade would take a half hour to pass a given point, and that the services would be held in the exhibition building. I am using your Mr. Ryan's Simplest Possible Super-Het, which I built myself from your directions, and a loop aerial."

**Izaak Walton League Will Enjoy "What Price Trout"**

**GRAND RAPIDS, Mich.**—Brrrrrr! (the alarm clock). "Wake up, John! It's 4 o'clock." (from his wife). "What for?" (this from sleepy Mr. Brown). "It's May 1," rejoins his better half. Yawns and squawks. Business of arranging tackle and hunting for mislaid favorite line.

Thus starts Wood's "What Price Trout," a fishing presentation celebrating the opening of the trout season in Western Michigan. The story of a day's fishing expedition, in the family flivver, up trunk line M54 to one of Michigan's famous trout streams.

The trip starts promptly at 9 p. m. Eastern time on May 3. "What Price Trout" is the ninth Mills-Wetzel presentation from the Furniture Capital station here.

**Oklahoma Station Continues Fight in Radio Slander Suit**

**OKLAHOMA CITY.**—The National Radio corporation, operating from Station KJFF here, recently entered a motion in the state district court to set aside a \$20,000 default judgment rendered against it in a case in which C. W. Fries, undersheriff of Oklahoma county, charged slander. The action was thrown out once on a demurrer, and counsel for the Radio company said they were not advised that it had been reinstated. They set out that they are prepared to make a defense and would have done so had they known the status of the case.

**SHORT WAVES**

By Marcella

A great many feminine hearts are aflutter over Norman Brokenshire, of WJZ. Too many, it seems to me, are curious for me to keep his personal habits a secret any longer. Well, Norman (you see I call him by his first name because he and I are great friends), is a very likeable chap. Bora in Murchison, Ont., Canada, about 28 years ago, he grew up more or less like Topsy and migrated to Cambridge, Mass., in early youth. Once he was a mechanical draftsman at Pittsfield, Mass. Then he was a doughboy during the world war. After the armistice he was selling things in New York—an occupation he could gather no love for—and one day he noticed a classified advertisement for a Radio announcer in a newspaper. He made the grade from out of a crowd of 500 replies. For a long time at WJZ, he was transferred to WRC, Washington for nearly a year. Then when the R. C. A. decided to open a superstation at New York to take the place of old WJZ, they called their best announcer, our friend Norman, back to handle the station. And he's still there. He's slightly under six feet tall, weighs about 165 pounds, wears a cute little mustache, and has romantic, curly, dark brown hair. And yes, J. H., Rena and Frances, he is single!

Says Mrs. M. J. E., "Wish you would write a little something about Ellen Rose Dickey of WLS. I like her a great deal and have been looking for a feature writeup of her in your women's section." Your prayer is answered in full. Just turn back to page six and look. We wouldn't do that for everybody, you know, but only our best friends.

More about George Hay? After reading what I told you two issues back you certainly should know almost everything. Well, the reason he left WLS, if you must know, is perfectly admissible. He likes Tennessee very much. WSM being there, and besides, because he likes to pay income tax, and he would have to pay more in the position WSM offered him, he accepted. What did he do before he became an announcer? He was a newspaperman. His experience in this line was extensive, and he still writes a corking good feature story. Look at my column in the April 17 issue for more details of his looks and life.

Wendell Hall is headin' South. Towns to be made, he tells me, include Charlotte, N. C.; Atlanta, Ga.; Memphis, Tenn.; Dallas and Fort Worth, Texas; Nashville, Tenn.; Hot Springs, Ark.; San Antonio and Houston, Texas; New Orleans, La., and Jacksonville, Fla. His "Little Girl from Chicago" is accompanying him.

Clyde Hager, formerly of WMBB, Chicago, is now out in Hollywood directing the studio destinies of the fourth movie colony to be on the air. KJZZ is the station, operating on 228 meters, or 1330 kilocycles. The studio is located in a sumptuously furnished California bungalow in the heart of the Hollywood residential district. Mr. Hager thinks he has one of the prettiest little studios in the country, and is completely sold on palm trees, orange blossoms and Mack Sennett bathing beauties.

**TIME SIGNALS WILL AID GOBI EXPLORERS**

**SPECIAL RECEIVER TAKE TO TUNE IN ON KDKA**

**Intrepid Desert Expedition Will Depend on Signals for Making Maps and Keeping Location**

**PITTSBURG, Pa.**—When Roy Chapman Andrews and his co-workers from the American Museum of Natural History set out from Peking, China, April 15 on their third Asiatic expedition, the technical staff took care to load their prized radio equipment on the back of their most trusted camel from the herd of 150 going with them into the unexplored wastes of the Gobi desert.

The scientists, who on returning from their last expedition brought news that they had found eggs ten million years old belonging to the Dinosaur, are setting forth this spring with two principal expectations: They hope to make discoveries even more notable than pre-historic eggs and to keep in touch with Westinghouse Station KDKA, here, whose time signals, they declare, will be of invaluable aid to the topographers in mapping and determining their latitude and longitude.

**Time Signals Important to Explorers**  
Word concerning the expedition's Radio plans is contained in a letter written by J. B. Shackelford of the technical staff to G. Dare Fleck, program director for KDKA.

To what extent the explorers of the desert will rely on KDKA's time signals is emphasized by the scientist who writes that they are carrying a receiving set built especially for long distance reception from this station.

"Music, news from home and other broadcasts will be welcome," he says "but most welcome of all will be the time signals from KDKA."

KDKA has received numerous letters commenting on the value of the time signals, particularly to vessels along the eastern coast and in the Gulf of Mexico. By means of this service Radio aids the mariners in keeping their correct bearings and safeguarding them against accidents along the coast.

Yes, John, the MacDowell sisters, Grace and Edith, still sing at WFAA. Yes, they still make records now and then at Kansas City. When I asked them if they were married or single, they replied by saying "Both." Which evidently means that one of them is and the other isn't, or both are. We think they mean the latter, for they are too interesting to stay single. Jolly, good-natured and pleasing, the two have thousands of Radio friends. As for a description of them, let them tell you:

"You can see by our pictures that we are not 'flappers,' as a great many young men seem to think, according to their letters. However, our Radio audience loves us in spite of it."

All those in favor, say aye.

What deep secret would you like to know about your favorite broadcast star? Drop me a note, girls and boys, and I'll do my best to answer here. MARCELLA.

# a STEP ON the STAIRS

## CHAPTER NINETEEN

*The Killer*

IT CANNOT be said that the late Jeremiah had been a popular figure in the community of Pelican Bay. As resident member of a family that had contributed so much to the history and wealth of Portsmouth and the bay shore he had moved in a rarified atmosphere, known for his ancestral associations rather than for anything that he himself said or did. Few indeed of the dwellers along the bay road or in the estates more closely adjoining beyond the cedars had ever seen Jeremiah at close range until the day when the whole county turned out to pay him honor and witness his departure from the old manse via the front door.

But for all that there was not a man, woman or child in the region who could not have recited every detail of his pedigree, biography and personal habits. The Turners had been a sort of hereditary legend in Pelican Bay for so long that their deeds had been woven into fireside tales and even cradle songs. And the community had felt a personal loss in his tragic removal—a loss for which there was no widespread friendship or great good will to account.

Something of the public attitude on the matter was reflected in the faces of the haggard guests, the state troopers and the secret service operatives as they stared in amazement at Peleg Turner, come back from the grave so opportunely to confess a fratricide.

"YOU killed him?" breathed Everett almost unbelievably. "You understand what you are saying?"

"I understand perfectly," replied Peleg with little or no show of emotion. "I came home unexpectedly the night before the killing. Afterward I went away and came home again. I shot him through the head over there on the hearth and a jolly good shot it was, too."

"Don't talk like that!" broke in Ardwyn hoarsely. "You don't know what your are saying, Peleg. Mr. Everett, Captain Cass, don't listen to him. The man is crazy."

"No, Ardwyn," Peleg interrupted with a shake of his head. "You are jumping at conclusions again. I am probably the sanest man in this room."

"If he wants to talk, let him," suggested Everett. "We might as well clear this thing up now. Mr. Turner, have you any explanation to make concerning why you killed him? Had you quarrelled with your brother?"

Old Peleg's gray eyes dulled as if with a mist and his voice was choking when he answered.

"No," he said. "We never had a quarrel. I loved Jeremiah. I looked after him since the day our mother died and left him in my care. . . . And that is why I have no regrets for what I have done. . . ."

Tolliver sniffed angrily.

"The old boy is off his nut," he confided to Hazel Stanton who happened to be nearest him. "Just another of these stories where a lunatic thinks he's conferring a favor on somebody by knocking him off."

"Keep quiet," retorted Hazel impatiently. "This is no affair of yours."

"It certainly is my affair," replied Tolliver in a hurt tone. "I been in it as deep as anybody else for three hours. . . ."

"Hush," commanded Hazel. "There's something more to this."

It was apparent that Everett shared something of Tolliver's view of the case for his next question showed his puzzlement over the discrepancy between Peleg's avowed affection and Peleg's casual confession of murder.

"You loved him so much that you murdered him?" he asked.

Peleg's eyes widened.

"Do you mean. . . ." he began. "But you can't mean. . . . Why I thought you knew. . . . I thought that was why you came here tonight. . . . I knew somebody had talked of opening the grave. . . . I didn't kill my brother. I killed the man the gang had put in here to take his place after they murdered him. The man on the hearth wasn't Jeremiah. He was a New York gunman. And I didn't murder him. I killed him in self-defense in a fair fight. . . ."

"Well I'll be doggoned," commented Tolliver.

## By ROBERT J. CASEY

Radio Dramatization by FRED SMITH

Illustrations by HILMER C. OLSON

"WE DIDN'T know any of this," said Everett.

"I am sorry gentlemen," apologized Peleg. "My head is a little muddled or I guess I'd have seen how the land lay. . . . Well it's easily explained."

"Hari Singh had been away. While he was gone I put Jeremiah in charge of this house and I went away, too. The cruise was to have lasted five years."

"Then Hari Singh came back here to look for a job from Jeremiah and he got hired because the gang thought he was a foreigner who didn't know anything about the neighborhood. But the man who was living in the house and passing himself off as my Brother Jeremiah was not Jeremiah and Hari Singh knew it. There was some resemblance—enough to pass with some pretty close friends when they came to look at him after a 45 bullet had messed up his face, but Hari Singh wasn't fooled. He sent for me and kept his eyes open."

"Do you mean to tell me that anybody could have passed himself off as a Turner in Pelican Bay without being detected instantly?" demanded Everett.

"I'm telling you just that," replied Peleg evenly. "The Turners are the best known people in these parts but it's mostly by hearsay. None of us ever stayed ashore long enough to pick up many friends."

"Anyway this man was passing himself off as Jeremiah Turner and doing a good job of it when I came home. I came in through the front door unexpectedly and he recognized me. He pulled a gun and I killed him."

"But your reported death?"

"All part of the same story. The gunman looked like Jeremiah. Therefore he looked like me. We buried him once as Jeremiah. Then we dug him up, shaved him and buried him a second time as Peleg Turner. It was really John Carton's idea. He had found that he could learn more by keeping out of sight."

"Then," commented Everett, with

some disappointment. "We're right back where we started from. Who did kill Jeremiah Turner?"

"I HAD hoped to find out tonight, gentlemen," Peleg replied. "But you know how the evening turned out. The man I killed was an underling. I don't know who killed my brother and I probably never shall."

"Perhaps I can help you out," suggested Mary Williams. "I think I can point out the murderer. . . ."

"I knew she had something to do with it," cried Aunt Helen Holmes. "I could feel it in my bones."

But no one paid attention to her. Everyone was looking at Mary, who had stepped away from the side of her police guard and now stood looking from one to another with half closed eyes.

"Well then who killed him?" snapped Everett.

"I can't tell you his name," said Mary. "We have no time to waste on guesswork."

"This is no guesswork, Mr. Everett. I know. The man who killed Jeremiah Turner is in this room and you can easily identify him. He is not Mr. Ardwyn, but he has a row of teeth marks on his wrist."

"How do you know that?" questioned Everett.

"Find him," commanded the girl. "Ask your questions afterward."

"Silly business," the secret service man declared. "But we'll see. Ladies and gentlemen, hold out your wrists."

The inspection took only a moment. Ardwyn's bandaged hand was passed and a quick glance about the room showed no similar wound.

"Sorry," Everett reported with mock courtesy. "You had me going for a minute, but everyone here seems to be intact. Have you any other suggestions?"

"Just one more," countered Mary Williams with a triumphant note in her voice. "Look at the man on the floor. I'd advise you to look in a hurry. He's regaining consciousness."

Everett looked.

"You're right," he admitted with a vehemence that showed he had finally been shaken out of his professional calm.

"The man's right wrist is bleeding."

"Why that's Cousin William Caryl," moaned Aunt Helen Holmes. "Why all this is preposterous! Cousin William wouldn't kill anybody. He wouldn't hurt a fly. That terrible woman is making all this up to damn an innocent man. She'd do anything, she's opening. . . . Ask him. . . . Ask him. . . . He's sending his eyes. Ask him. . . ."

Everett was raising Caryl's head from the floor.

"What happened to your wrist, Bill?" he asked in a calm wheedling tone.

"The boat got away and she bit me and I spilled the can of ether," muttered Caryl incoherently. "If I could have doped her maybe we could have got away. Peleg Turner won't be back for five years. Peleg Turner is dead."

"Out of his head," diagnosed Everett. "Evidently was going to gas somebody and got it himself."

"My wrist hurts," wailed Caryl, with increasing vigor. "Don't let her get at me now. . . . Don't let her. . . . Keep that cat away or I'll bump her off like I bumped old Jeremiah. . . . Like I bumped off old Jeremiah. . . . Like I bumped off. . . ."

## CHAPTER TWENTY

*A Door Closes*

EVERETT arose and turned apologetically to Mary Williams.

"Young woman," he said, "It appears that you were right. And I can't say that I'm particularly proud about the way we've treated you."

"It's nothing," replied Mary Williams. "You worked on what information you could get. My information was better. . . . That was all there was to it."

"Would you mind telling me how you knew William Caryl killed Jeremiah Turner?"

"Not at all. I was here when it happened."

"You saw the murder?"

"No. . . . I didn't see it. The thing happened here in this room in the dark. I could only hear what was going on. In the morning there was a new Jeremiah Turner in the place and I saw that I

(Continued on next page)

WHO WILL WIN THE

## \$500 in Gold

FOR SOLVING

### "a Step On the Stairs"

???

HERE it is—the tenth installment and conclusion to Mr. Casey's thrilling and carefully tangled mystery story. How many of you had an idea that Cousin William Caryl was the arch conspirator? Just how many the Mystery Story Editor does not yet know, but indications taken from the solutions so far submitted by readers, or by listeners to the drama over the air, point to the statement that very few, if any, even suspected that the pious William was supposed to play a very important role.

But watch for next issue—that of May 15—which will be on all news stands by Friday May 14. In it will be announced the winners of the \$500 in gold prizes for the best solutions to the story. Each of the principal winning solutions will be criticized by the Mystery Story Editor. It may even be feasible to reprint in whole a few of the best.

By the way, have you begun to read Big Rabbit, by Hugh Fullerton? Mr. Fullerton, whose name came into prominence some years ago when he said he knew 10,000 people—by name—is, like Mr. Casey, a graduate of the daily newspaper office. For years he has been associated with the largest morning daily newspaper in the United States. Knowing himself, he knows newspaper men and is well qualified to write a fiction story about them.

If you haven't read Big Rabbit, turn back to page eight and do it now.

AN EVENING AT HOME WITH THE LISTENER IN CENTRAL TIME

Table with columns: Call, Location, Met., Saturday, Sunday, Monday, Tuesday, Wednesday, Thursday, Friday. Lists various radio stations and their broadcast schedules.

STATIONS IN ORDER OF WAVE LENGTHS

Table with columns: Meters, Call, Meters, Call, Meters, Call, Meters, Call, Meters, Call, Meters, Call. Lists radio stations ordered by wavelength.

"A STEP ON THE STAIRS"

(Continued from preceding page)

My hand was fractured by Hari Singh. "Where was Jeremiah Turner?" "I'm getting to that . . . As I said, it would have difficulties if I went to the village constable at Pelican Bay and told him my story. I thought I'd make sure. "Before Peleg Turner started on his long cruise I always had the run of this house. I had a few people know about it because an Uncle Peleg had explained, he did not have many intimates. I used to play around here with John Carton when we both were little children. I kept coming over to see Uncle Peleg after John went away to college. "On the night of the murder I ran over in my car from Portsmouth to ask Uncle Peleg when Johnny was coming home. The door was open so I walked in. "You did not know then that Peleg Turner had brought his baggage here and left on a long cruise?" asked Everett. "I had heard that he was going on a cruise. He told me so in Portsmouth when he came up to say goodbye. But he had said something about going back to the house for a day or two. There was a chance that he was still at home. "Did you see Jeremiah Turner?" "No sir. . . I never saw Jeremiah Turner. . . I walked into the house as I said and I was just about to call out when I heard strange voices in the hall. "Two men were talking. I gathered that they had some sort of a job to do. "John Carton will be home from school tomorrow or next day, one of them said. "And if he sees Jeremiah Turner it will be too late then to make any substitution. "I GOT down on my hands and knees and crawled to the hall door. It was dark in the hall-room except for a little moonlight coming through that window over there. I saw some sort of a bundle on the floor. "The second man spoke then. . . I thought his voice was familiar, but he spoke in whispers and I couldn't be sure. "You're sure this Carton kid never saw his uncle Jerry," he asked. And the first man said, "Not a chance. Jeremiah was brought back here from India. He's been over there fifteen years. "Then," the second man said, "I guess you'd better solve your problem now. "What about you?" the first one asked and the second laughed. "It's your funeral," he said. "This is your gang and you can run it to suit yourself. But you didn't hire me to solve any puzzles. Me, I'm getting out of here right now. "Then there was a long silence. It puzzled me then. It kept puzzling me until tonight. I know now that the second man meant out through the front door. I also know now that he was Milford Jones

whose skull was fractured by Hari Singh. "Where was Jeremiah Turner?" "I'm getting to that . . . As I said, it would have difficulties if I went to the village constable at Pelican Bay and told him my story. I thought I'd make sure. "Before Peleg Turner started on his long cruise I always had the run of this house. I had a few people know about it because an Uncle Peleg had explained, he did not have many intimates. I used to play around here with John Carton when we both were little children. I kept coming over to see Uncle Peleg after John went away to college. "On the night of the murder I ran over in my car from Portsmouth to ask Uncle Peleg when Johnny was coming home. The door was open so I walked in. "You did not know then that Peleg Turner had brought his baggage here and left on a long cruise?" asked Everett. "I had heard that he was going on a cruise. He told me so in Portsmouth when he came up to say goodbye. But he had said something about going back to the house for a day or two. There was a chance that he was still at home. "Did you see Jeremiah Turner?" "No sir. . . I never saw Jeremiah Turner. . . I walked into the house as I said and I was just about to call out when I heard strange voices in the hall. "Two men were talking. I gathered that they had some sort of a job to do. "John Carton will be home from school tomorrow or next day, one of them said. "And if he sees Jeremiah Turner it will be too late then to make any substitution. "I GOT down on my hands and knees and crawled to the hall door. It was dark in the hall-room except for a little moonlight coming through that window over there. I saw some sort of a bundle on the floor. "The second man spoke then. . . I thought his voice was familiar, but he spoke in whispers and I couldn't be sure. "You're sure this Carton kid never saw his uncle Jerry," he asked. And the first man said, "Not a chance. Jeremiah was brought back here from India. He's been over there fifteen years. "Then," the second man said, "I guess you'd better solve your problem now. "What about you?" the first one asked and the second laughed. "It's your funeral," he said. "This is your gang and you can run it to suit yourself. But you didn't hire me to solve any puzzles. Me, I'm getting out of here right now. "Then there was a long silence. It puzzled me then. It kept puzzling me until tonight. I know now that the second man meant out through the front door. I also know now that he was Milford Jones

(Continued on page 25)

# Let's Bury the Demon Static

WITHIN the last few months, several experimenters have taken an unusual interest in the subject of antennas. Such experiments followed the publication by Radio Digest of articles upon underground antennas, by such men as Dr. J. Harris Rogers, George Guyer and Edward T. Jones. The immediate result of these articles was the development of an army of experimenters who installed the types suggested by these men. If the scheme worked it was good, if it didn't, then it was a failure; but out of the maze came the evidence that thousands were interested.

Realizing the problem was one which should be approached with an added thoroughness and that success could only be attained through having a great many experimenters scattered throughout the United States the following plan was devised:

Radio Digest will attempt to supply through its columns at regular intervals all of the information now available upon underground receptors together with other types worthy of trying. In addition, it will suggest constructional ideas for experimentation, together with excerpts from experimenters' reports as received.

### Success Depends on Reports

It is obvious that the success to be obtained is entirely dependent upon the number of readers who will assist in making the experiments. This therefore, is an invitation to all who will help, to forward their names and addresses to the Technical Editor. We desire to secure co-workers from every state in the Union, as the study will cover soil, climatic and all conditions which may have a bearing upon the subject.

While these experiments will, in a large measure cover the subject of underground antennas, the primary object will be to limit, so far as possible, the influence of static. Therefore, suggested experiments covering antennas with other locations than underground will be studied.

An intensive effort has been made to collect data upon many types of underground aeriols. There are a great many experimenters who have done research along this line and correspondence covering the application of their ideas, together with the results obtained, is likewise solicited in order that it may be passed on to others.

### Localities Differ

In order to acquaint those who were unfortunate in not having followed the able articles of the gentlemen mentioned above, a resume of their work will be offered, together with the results obtained in their localities. It must be borne in mind that the results in each instance apply only to the locality of the installation and are likely to vary in other locations according to the moisture content of the earth.

Mr. Guyer's most satisfactory reception was had from an installation following that pictured in figure 1. This consisted of two lengths of No. 14, 7-strand insulated copper wire, each 50 feet long and coiled about 4 feet apart and approximately 4 feet underground. Laying the wire in solenoid or circular form and spacing each turn one above the other with half inch separations, the finished inductance, in Mr. Guyer's locality, left little to be desired. The spacing of the turns was accomplished by filling in with soil as each layer was placed. After completion, the ground was thoroughly soaked in order that a good moisture content might be secured.

We repeat Mr. Guyer's original description of the results he secured from this novel installation, in the belief that many will desire to use it for their first experiment:

### Joy to Operate

"Many tests have given me the expected volume and the elimination of the water pipe disturbance and also proved that this last coil works equally well interchangeably with the first on either the antenna, or ground post of the set. I now have a real underground antenna system which is a joy to operate. If you desire similar results be careful to follow instructions in installing your underground system.

"General results are satisfactory beyond my expectations. The volume is splendid. I obtained clear, distinct, resonant and fluidic reception, entirely free from the gaseous, atmospheric conditions led into the set through the usual aerial antenna or loop, but not entirely free, at particular times which you will discover, from those other hindrances and disturbing factors heretofore pointed out.

### A Remarkable Reception Record

"All my tryouts in the experiments have been made with my super-heterodyne. It occurred to me that my fine reception might be due, at least in part, to the radio frequency feature of the set, and that a set without such feature might not give such satisfactory results. I borrowed a three tube set—detector and two stages of audio frequency amplification which I had built for another party, with which to give this antenna

*MANY Fans, We Venture to Say, Do Not Know that It Is Perfectly Feasible and Practical to Bury an Antenna, According to the Rules Given Here, and Be Happy All Summer Long*

By MILO GURNEY

equipment a tryout. The set used 201A tubes throughout with 90 volts on the plate. I first tested out static conditions through the aerial antenna. Static was overwhelming, rendering reception intolerable. I hooked the set to the underground antenna and turned the tuning dial.

### Volume and Clarity

"To my utter astonishment and joyful surprise fluidic music coming from the studio of WSAI at Cincinnati,

see how many distant stations I could tune in, with the detector alone.

"At this sitting I tuned in WLS, WLW, WCBW, WMAQ, KDKA, WREO, WWJ, WCCO, KFI, KHJ, KNX, WGN and KYW. This convinced me that the underground antenna system herein described will work well with any receiving set—provided it is a real receiving set. The distance from the point of operation to the various stations above named will range from 900 to 1,900 miles."

**Editor's Note.**—Mr. Gurney's second article of this interesting series will reveal an additional experiment in conjunction with Mr. Guyer's underground aerial.

## "HIGH-BROW" AND PROUD OF IT

(Continued from page 7)

Naturally early experimenters with voice transmission were quick to see the possibilities of the improved pickup device that the new carbon presented and in 1910, under the direction of Mr. Turner, the operas "Cavalleria Rusticana" and "Pagliacci" were broadcast from the stage of the Metropolitan Opera House. Possibly an audience of 200 experimenters and scientists picked up this broadcast, which clearly demonstrated the improved efficiency of the new microphone over all preceding devices. Today, should the same broadcast privilege be granted a total of 20,000,000 people could hear these famous operas. And while the Metropolitan Opera today refuses to allow its operas to go out on the air, it set a precedent way back in 1910.

### Builds Hollywood Station

For the next fifteen years following the broadcasting of these operas, K. M. Turner did not again experiment with Radio transmission, being too deeply engrossed in the manufacture and sale of the acousticon and dictograph. In the spring of 1925, however, then living in Hollywood, California, he decided that Radio had finally emerged from the chrysalis stage and that the time had come when someone should step in and show the way for the Radio station of the future. Several wealthy Los Angeles men were interested in this station that would be different and proceeding slowly, a homemade 50-watt station was put on the air to test the theories of its founder.

It developed immediately there was a large audience ready and anxious to listen to the kind of entertainment KMTR was furnishing, so a 500-watt Western Electric transmitter was installed in the little building on North Wilton Place, Hollywood, and KMTR set out to find its place in the air. After the station was on the air eight months and running smoothly, K. M. Turner stepped out. Nearing 70 years of age, he felt younger men should control this young industry, Radio.

### Selects Philharmonic Stars

Briefly, that is the story of KMTR. Those living within reach can tune to 238 meters any evening except Sunday, between the hours of 8 and 10 p. m. Pacific time, with a certainty of hearing first-class concert music played by the KMTR concert orchestra, an organization of first chair men of the Los Angeles Philharmonic orchestra led by Loren Powell, first violin of that famous orchestra. The KMTR concert orchestra plays concert music only, and to enable listeners to know exactly what selections will be played on any one night, detailed programs for one month in advance are mailed to a large audience. The station is non-commercial, that is, does not put on programs for toll and the expense is borne by several well-known Los Angeles business men who do not wish their names mentioned.

Carlton King, or "Dad" King as he is known, is the announcer and studio manager of the station. He fits the part. An actor of considerable experience he was in charge of the Navy club in New York, during the World War and later directed and produced motion pictures for his own company. His popularity with the Radio audience is shown by the success of his Morning Family Circle which goes on the air daily at 9 a. m.

Possibly the biggest feature of KMTR, and undoubtedly the biggest with the children, is the home hour broadcast from 5 to 6 p. m. daily except Saturday and Sunday. The home hour is presided over by Georgia Simmons, or Mammy Simmons as she is known to everyone. A real Southerner from the South, an experienced story teller to the children, her hour at KMTR was a big success from (Continued on page 28)

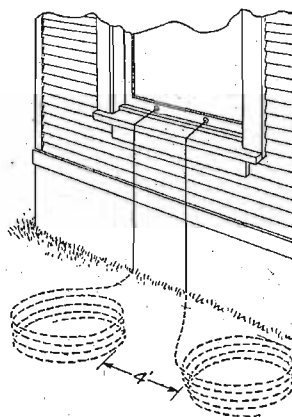

Figure 1. One of the most simple and effective methods of installing an underground antenna is described by Mr. George Guyer and pictured above. One need not dig up the whole yard for this first experiment.

## How About You?

HAVE you had experience with an underground aerial? If it was successful what did you learn about it? We wish to gather together all the information possible concerning experiments on the underground aerial for broadcast reception.

We know that the underground antenna system is a great static reducer. However, there are hundreds of variations one may make in the installation of such an antenna. Some of these have proven themselves superior to others—for given localities, climates and types of soil.

If you have experimented with this type of reception, drop Mr. Gurney a note telling all about it.

There are other methods of improving summer Radio. If you, by study or good fortune, have learned of some system or trick to deliver the music better in the warm months, consider yourself also invited to correspond with Mr. Gurney.

—THE EDITOR.

# Radio Digest

## Illustrated

Reg. U. S. Pat. Off. & Dom. of Canada

Published by the  
**RADIO DIGEST PUBLISHING CO.,**  
 (Incorporated)  
 516 North Dearborn Street  
 Chicago, Illinois  
 Telephones: Superior 7323, 7324, 7325, 7326, 7327

E. C. RAYNER, Publisher

Eastern Office, Park-Lexington Building, 247 Park Ave.,  
 New York. Telephones: Astoria, 5144, 5145, 5146

Member of the Audit Bureau of Circulations

241

PUBLISHED SEMI-MONTHLY

SUBSCRIPTION RATES

Yearly in U. S. and Possessions and Canada, \$3.00  
 Foreign Postage, \$1.00 additional. Single copies, 15 cents.

Vol. XVII May 1, 1928 No. 4

### Nice Weather We're Having

WE HAVE been doing an unusual amount of listening of late, chiefly, we believe, because the Radio weather has been so consistently good. So opens many a conversation in which the participants become embroiled in a competition of telling the biggest ones. However, we shall not start such a Radio story contest.

Of course, a spell of good reception is due us, for January, February, and even March, certainly fell very far short of expectations. Perhaps the order has been so far reversed that we may have good listening even through June. Sun spots, the weather, atmospherics and Radio range are peculiar things.

Wonder how you listen in. When we decide to stay home and enjoy a Radio evening, we follow a set procedure. Early in the evening we tune in KDKA first, then WOC. If these two come through loud and clear, with a low static-to-signal ratio, then we are assured we can cruise the country and hear what we desire. Time enough then it is to study the programs.

We find the columns of this publication unusually helpful here. We read the "headliners today" and check those in which we are interested. If not particularly interested in the headliners, we go further and read through the detailed programs to find where and when our best-liked entertainers are broadcasting, or where our favorite type of music, talk or other entertainment is to be found. Then we plan our evening by the clock.

Our receiver has been carefully logged. If, when we set the dials, the station does not come through with volume and good quality, we can only blame nature for some trick to shut the station out. We don't blame the receiver unless WOC and KDKA have come through clearly.

We wonder how it was possible for us to get along without a set not so many years ago. We feel a personal interest in artists we have never seen, in cities we have never visited, in topics discussed over the air which would not interest us in print.

Here we are—talking about something foreign to the good Radio weather we began to talk about. But most conversations start with the weather, and we hope the present brand of it continues.

### Plant Your Garden Antenna Early

ABOUT this time of the year the wife hands you a spade and tells you to go out and dig up the ground for a garden, pardon us, THE garden—wherein many beautiful examples of the gardener's art are supposed to grow and attempt to live up to the pictures of themselves on the seed packets.

Some of us get a kick out of digging in the garden. Others of us, however, are more inclined to tinker with the Radio set, both at a baseball game, crawl under and overhaul the flivver, or yell, "Fore," as we swing away at a small white sphere resting on a cone of sand. To the second class mentioned, which includes many in the other classes named, we submit this excellent suggestion to be used for what it is worth, providing of course, your wife insists that you dig that garden.

First read the article in this issue on the subject of underground antennas. Take it from us that they are good. They reduce summer static outbursts to their proper place in the order of things. Radio Digest first discovered that Dr. J. Harris Rogers had produced working underground antenna which would reduce the static ratio and increase the chances of you hearing programs without your ear drums being burst. And Radio Digest is again recommending it to you.

Next take the spade your wife gives you and dig the garden and the hole for the underground antenna. Of course, the third and most logical step is to plant the garden and the antenna. However, we would mark this point of difference:

The garden may not come up to your expectations, but the underground antenna will make up for this deficit by supplying you with good Radio programs all summer long.

## RADIO INDI-GEST

### Your Presence

Last night my heart was sore oppressed with gloom  
 And in the quiet of the room  
 I sat in loneliness and wept.  
 And as the stealthy silence round me crept,  
 I turned to the Radio to bring me cheer  
 And to hear the voice I love so dear.  
 My aching heart was breaking with despair  
 When lo, I sensed your presence in the air.  
 I listened for the words you often say,  
 But you came not to talk, nor long to stay;  
 I wept no more, and reaching for your hand  
 Again I felt your magic—the power to understand.  
 You softly pressed your cheek against my face,  
 Then waking suddenly, my heart was stirred  
 By a dream more eloquent than any work.  
 "THAT RED HEAD GAL"

### Choose Your Weapons, Gentlemen

Dear Indi: Why this eternal controversy? Can't you settle it? Suggest you get the Third Trombone Player and Dielectric in Webster Arena, Pabst Park, and let them have at it with seven syllable words and pewter steins. And let the best man brag about it.

PETE PETITE

### Cilly Circuits

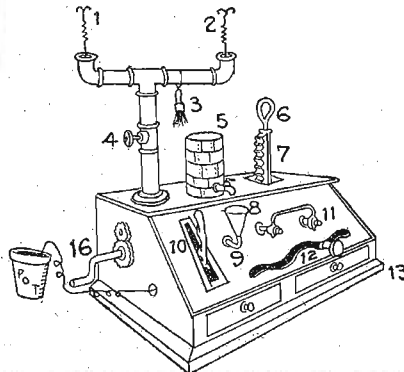

Dear Indi: This hook-up is the Orphanola UV-20 and was designed after listening to several experts discuss, argue and lecture on the subject of Radio during office hours in an engineering department. It is Dale's circuit. The parts follow: 1, Antenna and impedance checker; 2, low loss feature; 3, tickler; 4, wire to regulate frequency accuracy; 5, standard loss feature; 6, coil; 7, rack to produce straight line reception; 8, grid leak; 9, feed back; 10, station puller; 11, shafts connected so one-armed man can operate; 12, wave length producer; 13, concrete base for test-armed man can operate; 14 and 15 shown in figure 2; 16, gears for changing diameter of coils; pot at left contains ground.

JOHN J. SCHEIDT

### Silent Night

'Tis Silent Night with me tonight,  
 I sit and read and smoke  
 And listen to the family talk  
 And hear them laugh and joke.  
 I do not turn and twist the dials  
 And DX try to get—  
 I do not cuss my neighbor  
 With his blooping super-het.  
 I do not fuss and fume and roar—  
 Just let the bloopers bloop.  
 For silent is the night for me—  
 My battery's in the shop!

OLD KING TUTT

### Tuned Himself Out

Dear Indi: With the aid of Sir Oliver Lodge and Sir Conan Doyle, I have just pulled off an interview with the spirit of the first Englishman ever to commit suicide with the aid of his Radio.

He never tuned in to jazz, only to music. When the latter came along it happened to be Mendelssohn's "Funeral March." Struck by the majestic beauty of the piece and feeling that it was being played in vain, he heroically gave his life as a sound reason for the broadcast.

LONDON BOBBY

### Radio Rhymes

There, little crystal set,  
 Don't you cry—  
 You'll be a hel'rodnyne  
 Bye-an-bye!

SANTA FE BALDY

### Might Freeze You Out

Edator Indi: I got a letter from the Patent dept. of U. S today and he said they was getting the final papers out on my lee machine. I have been offrd some Florida property for it but I aint as dumm as I look. One man has offrd me 1/2 interest in Ellis Island, just off New York harbour. I am going to think it over. He says he gets lots of money out of it, renting rooms to fore-nurs. I think it would be a good trade, don't you?

Always as ever

KITTLE DRUMMER

### FRANQUE FILOSOFEE

He Who Lies Last, Lies Best.

INDI

## Police Protection



## Condensed

BY DIELECTRIC

Sport fans are at last furnished from headquarters with the first-hand news of events in the ring, etc., which call forth the enthusiasm of excited crowds at the ringside. We may not "see" all the big fights as they are staged in the arena at Madison Square Garden, New York, but surely enough "good" fights will be pulled to make us grateful for the broadcasting by Tex Rickard from Station WMSS. The initial program featured some speakers of national fame and music equal to most that is heard nowadays. Announcement was made that this new station will aim to foster and develop interest in sporting events of all sorts. Ringing circus miked pretty well.

Station WNAC, Boston, presented a concert orchestra program the other evening which was a delight to anyone interested in this class of music. Selections were chosen that gave free play for individual voices in the orchestra to be heard in a kind of obligato effect. After listening a long time to numbers allowing no such variation, it is refreshing to hear a flute, oboe, clarinet, French horn or tuba carry the theme above the accompanying instruments. It isn't necessary to choose "heavy" numbers for such presentation.

Another community concert proved satisfactory when Station WCCO, Minneapolis-St. Paul, staged one recently. It compared very favorably with those better known to the Radio public because of more frequent presentation and included instrumental selections well rendered. Somehow there is a feeling of informal fellowship when tuned to a community affair. It proved a good innovation.

Now the lovers of Hawaiian melodies must have their fill since Station WBAP, Fort Worth, had the good luck to present the Panther Hawaiian trio to their Radio audience. That doesn't mean that they wouldn't want to come back for more of the same entertainment, for they undoubtedly would, but merely to say how enjoyable it was.

An acceptable studio recital program was presented from Station WJR, Detroit, at least, it may have been liked by most listeners throughout. At any rate, one of the features had a lot to commend itself, and that was the quartet which sang with the sole intent to make friends of those tuned in. If there is lacking an unrestrained volley of encomiums, lay the fault at the door of an interfering station because of which the reception was nearly ruined.

Speaking of operations, the Evanston hospital will find itself flooded with applicants for admission following that concert by their nurses glee club a short time ago. Paradoxical as it may be, the really fine work of this glee club made many invite sickness just to be where those voices could be tuned in by pushing a buzzer. How else may the character of their ensemble singing be eulogized so emphatically. Our thanks to Station WEBB, Chicago.

Station WHT, Chicago, puts on a popular music feature which may appeal to many listeners. The best way to describe it to you is to suggest looking up their schedule and trying it out for yourself. I hope you'll like it, as the leader of one of our popular orchestras playing Bach fugues exclusively expresses his desire for approval.

SABBATH SHOULD BE MOTHER'S REST DAY

SIMPLE DINNERS ALLOW MORE LEISURE TIME

Careful Planning and Some Preparation Beforehand Will Make Sunday More Enjoyable for Housewife

Have you heard, and do you regularly listen for Betty Crocker's Radio talks? Miss Crocker is nationally known as a home food specialist who is broadcasting from a dozen of the country's latest stations.

WEIN America take great pleasure in promoting movements. We organize campaigns to improve child health and to conserve our natural resources.

We have traveled a long way from the strict observance of the Sabbath, which necessitated the preparation of all the food the day before.

By careful planning and some preparation beforehand, it is entirely possible to have a nice dinner even for guests and yet to prepare it with a minimum of time and effort.

Whatever your cooking equipment, meat that is broiled or cooked in the fry-

ing pan requires less time for cooking, but demands more attention at a time when you are preparing many other things.

Prepare Vegetables Day Before It is an advantage to have the meat and vegetables combined in a casserole.

Method: Wipe the meat with a damp cloth. Dredge with flour. Sprinkle with salt and pepper.

Baked Ham Good Oven Dinner Another good suggestion for an oven dinner is to bake a slice of ham with raw sliced potatoes over the top.

Meat loaf is always good. It may be prepared the day before or put on to bake early, or it may be baked on Saturday and reheated for Sunday dinner.

ANOTHER WOMAN IS PROGRAM DIRECTOR



Mrs. J. S. Pamplin

SAINT PETERSBURG, Fla.—Radio has opened new occupations to women, and Station WIBC here is demonstrating that they can be successful in these new positions.

As artist, teacher and coach, Madam Pamplin is one of Florida's leading musicians.

Meat loaf is always good. It may be prepared the day before or put on to bake early, or it may be baked on Saturday and reheated for Sunday dinner.

Meat balls convenient One of the most convenient quick meats is meat balls cooked in tomato sauce.

Meat loaf is always good. It may be prepared the day before or put on to bake early, or it may be baked on Saturday and reheated for Sunday dinner.

browned and partly cooked, pour over a can of tomato soup and let simmer slowly until done.

For new occupations, fresh fruit with cake or cookies attractively served is quite as acceptable as any elaborate dessert.

Radio Club Notes

A superpower line, carrying 50,000 volts through northern New York, was found to be the source of interference experienced by Radio listeners in that section.

Here is good news for those living "out where the tall corn grows". The engineering department of the Iowa State Agricultural college, Ames, Iowa, have outlined a plan to pass legislation upon all types of Radio receivers sent them.

Phone Wires Link KHQ to KJR

SEATTLE, Wash.—For the first time in the northwest several broadcasting stations, KJR at Seattle and KHQ at Spokane, were tied in simultaneous line for an experiment to send out the weekly program of the Keep Joy Radiating Order from their Belfry at KJR.

WOMEN'S PROGRAMS INDEX

Saturday

Table listing radio programs for Saturday, including stations like Atlantic, Eastern, Central, Mountain, Pacific and program titles such as 'Six Years Old—What's in Store for the First Year of School'.

Monday

Table listing radio programs for Monday, including stations like Atlantic, Eastern, Central, Mountain, Pacific and program titles such as 'Home Economics', 'Fashion and Household Talks'.

Wednesday

Table listing radio programs for Wednesday, including stations like Atlantic, Eastern, Central, Mountain, Pacific and program titles such as 'Home Economics', 'Fashion and Household Talks'.

Table listing radio programs for Saturday (continued), including stations like Atlantic, Eastern, Central, Mountain, Pacific and program titles such as 'Home Economics', 'Fashion and Household Talks'.

Tuesday

Table listing radio programs for Tuesday, including stations like Atlantic, Eastern, Central, Mountain, Pacific and program titles such as 'Home Economics', 'Fashion and Household Talks'.

Wednesday

Table listing radio programs for Wednesday (continued), including stations like Atlantic, Eastern, Central, Mountain, Pacific and program titles such as 'Home Economics', 'Fashion and Household Talks'.

Table listing radio programs for Saturday (continued), including stations like Atlantic, Eastern, Central, Mountain, Pacific and program titles such as 'Home Economics', 'Fashion and Household Talks'.

Tuesday

Table listing radio programs for Tuesday (continued), including stations like Atlantic, Eastern, Central, Mountain, Pacific and program titles such as 'Home Economics', 'Fashion and Household Talks'.

Wednesday

Table listing radio programs for Wednesday (continued), including stations like Atlantic, Eastern, Central, Mountain, Pacific and program titles such as 'Home Economics', 'Fashion and Household Talks'.

Table listing radio programs for Saturday (continued), including stations like Atlantic, Eastern, Central, Mountain, Pacific and program titles such as 'Home Economics', 'Fashion and Household Talks'.

Friday

Table listing radio programs for Friday, including stations like Atlantic, Eastern, Central, Mountain, Pacific and program titles such as 'Home Economics', 'Fashion and Household Talks'.

Thursday

Table listing radio programs for Thursday, including stations like Atlantic, Eastern, Central, Mountain, Pacific and program titles such as 'Home Economics', 'Fashion and Household Talks'.

GARLANDS OF AIRY TUNES WILL BI

High Lights of the Air

GARLANDS of airy tunes will welcome in the first of May this year instead of the bright nosegays formerly dropped on the doorsteps. These gay melodies bringing whiffs of forest music will be the May Day gift of the Radio stations. No Radio fan will escape the charm of this Pied Piper, spring.

The Swanee Symphony, the dance attraction on the Saturday night programs of Station WRC, have been named the second best Radio dance orchestra in the United States by Stuart Rogers, New York Radio critic. They were topped only by Vincent Lopez' Orchestra of New York. The Syncopters play regularly under the direction of Al Kamons.

National music week will be observed by WTIC with features arranged by music lovers of New Haven. The New Haven Symphony orchestra, Horatio Park choir, the University Glee club, May Bradley Kelsey, soprano, and Harry B. Jepson, organist, will be featured during the Sunday afternoon concert May 2. On May 5 at 7:15 p. m. Eastern Standard time a grand opera concert will be presented from Dorscht hall. On May 6, at the same time, a sacred concert will be given under the direction of Leroy Baumgartner. Prof. Harry B. Jepson, organist, and the New Haven high school orchestra are the features of the Friday program.

Already the spring of the year brings promise of merry sunshine during summer vacations, and "the call of the wild" will be distinctly felt during the concert Tuesday, May 4, between 9 and 10 p. m. Pacific time, given in honor of Yosemite. Anthony Linden, solo flutist of the San Francisco orchestra, Glen Hood, banjoist, and Camp Curry's popular entertainer will be heard. Don Tweedler gives a talk on "The Outdoors."

Oratorios famous throughout the ages will be played by the KDKA Little Symphony orchestra Tuesday evening, May 11. This program will give in an attractive manner the history of this musical form.

Greg's lovely Peer Gynt suite has been heard from many stations during the short life of Radio, but for the first time the poetic form of Ibsen's play will be broadcast Tuesday, May 11, by WGN, Chicago. The WGN ensemble will play the musical background.

Friday evening, May 7, the newly organized W.D.A.L. quartet will broadcast its first concert from 10 to 10:30 p. m. Eastern Standard time. The members of this feature include: Louise Cline, soprano; Maud Albert, contralto; John Wilbourn, tenor; Walter N. Linthicum, basso. This quartet of well-known Baltimore artists is to be a regular Friday event.

KYW, Chicago, Ill. (435.4m-560k), 5-5:30 p. m., dinner music, KDKA; 6:30-8, home-lovers' hour; 8-9, an hour of music; 9-10, Congress class; 10:05-11, Congress carnival.

WBAP, Fort Worth, Tex. (475.9m-630k), 9:30-11 p. m., Wendell Hall, The Red-Headed Music Maker.

WCCO, Minneapolis-St. Paul, Minn. (418.4m-720k), 8:15 p. m., Wrayway Bayway's Nicollet hotel orchestra, 8:35, music; 10:05, Wallie Ericson's Coliseum orchestra.

WDAF, Kansas City, Mo. (365.6m-620k), 6-7 p. m., organ music; Triumphant ensemble; 11:45-1 a. m., Night-hawk radio.

WFAA, Dallas, Tex. (475.9m-630k), 6:30-7:30 p. m., Junita Jolly's orchestra; 8:30-9:30, Mrs. Albert Smith, soprano; Mrs. H. Parks, contralto; 11-12, Jack Gardner's orchestra.

WLAS, Louisville, Ky. (309.8m-750k), 7:30-9 p. m., mixed vocal and instrumental concert, Arthur Pfundlin, baritone.

WMO, Memphis, Tenn. (499.7m-600k), 8:30 p. m., Alumnae association, Mississippi State College for Women.

WQAW, Omaha, Neb. (526m-570k), 6:30 p. m., orchestra; 8 p. m., Frank Holick and his National music orchestra.

WOC, Davenport, Iowa (483.0m-620k), 9-10 p. m., Mrs. Marger-Goss, soprano; R. W. Schoenig, baritone; May Marshall, soprano.

WRR, Dallas, Tex. (245.8m-1220k), 6-7 p. m., dinner hour concert, Jack Gardner's orchestra; 8-9, varied



Los Angeles being port of entry from Hawaii, has more Among the most popular of KFI, are the Hawaiian Brothers To the left is the Tuesday evening feature of WLW, Mary Malone, soprano, who sings frequ

Saturday, May 1

Headlines Today

Table with columns for station call letters and program details for Saturday, May 1. Includes stations like Atlantic Eastern Central Mountain Pacific and programs like 'The Million Diner' and 'The Melody Lady'.

chests; 10:30, (399.5m-760k), Kitchen Kleener entertainment; 10:30, Jack Turner, popular singer; Irene Smith; 12, your hour league.

Atlantic or Eastern Daylight Saving Time Stations

WBRR, New York, N. Y. (272.6m-1100k), 8 p. m., Dr. Henry Hines, violinist; 8:30, 'The Newswoman' concert; 9:30, 'The Melody Lady'.

Eastern Standard or Central Daylight Saving Time Stations

KDKA, Pittsburgh, Pa. (398.1m-670k), 8:30 p. m., concert; 8:30, concert.

WMBB, Chicago, Ill. (249.9m-1200k), 7-8 p. m., Triumphant ensemble; 11:45-1 a. m., Night-hawk radio.

Central Standard Time Stations

KFAB, Lincoln, Neb. (247.7m-880k), 8:30-9 p. m., dinner concert; 8:30-10:30, Siena Alpha Unit; 12-2, orchestra.

Headlines Today

Table with columns for station call letters and program details for Sunday, May 2. Includes stations like Atlantic Eastern Central Mountain Pacific and programs like 'The Melody Lady' and 'The Million Diner'.

Atlantic or Eastern Daylight Saving Time Stations

WBRR, New York, N. Y. (272.6m-1100k), 10 a. m., Watchtower radio, church services; 2:30, Watchtower orchestra; 8, string quartet.

Eastern Standard or Central Daylight Saving Time Stations

KDKA, Pittsburgh, Pa. (398.1m-670k), 8:30 p. m., concert; 8:30, concert.

Sunday, May 2

Headlines Today

Table with columns for station call letters and program details for Sunday, May 2. Includes stations like Atlantic Eastern Central Mountain Pacific and programs like 'The Melody Lady' and 'The Million Diner'.

Atlantic or Eastern Daylight Saving Time Stations

WBRR, New York, N. Y. (272.6m-1100k), 10 a. m., Watchtower radio, church services; 2:30, Watchtower orchestra; 8, string quartet.

Eastern Standard or Central Daylight Saving Time Stations

KDKA, Pittsburgh, Pa. (398.1m-670k), 8:30 p. m., concert; 8:30, concert.

DANCING

Table listing dance events and times for various stations on Sunday, May 2. Includes events like 'The Melody Lady' and 'The Million Diner'.









Wednesday, May 5

orchestra; instrumental trio; Aenes Clark Glaiser, soprano; Edward Weston, baritone; Della Hoover Francis, violinist; 10-12, Broadway Rhythm Rustlers.

Pacific Standard Time Stations

KFI, Los Angeles, Calif. (467m-642kc), 7-8 p. m. Greco Synchronizing string ensemble; 7:50-8 p. m. Harris' detective story; 8-9 p. m. program, Ventura Refining company; 9-10 p. m. program, Y. S. Stewart Corp.; 10-11 p. m. program of dance and popular songs.

Thursday, May 6

Headliners Today

Atlantic Eastern Central Mountain Pacific 9 p. m. 7 6 5 4 3 2 1. KFPA (263m-114kc), Old-time music; 9-10 p. m. WHAS (539.9m-730kc), Gipsy band; 9-10 p. m. KDKA (899.1m-970kc), Old fashioned quartet; 10-11 p. m. WJAZ (326.9m-810kc), Vocal soloists; 10-11 p. m. WJAZ (326.9m-810kc), Vocal soloists; 10-11 p. m. WJAZ (326.9m-810kc), Vocal soloists.

Thursday, silent night for: CNIC, CNKC, CNKA, CNRE, CNRO, CNRB, CNRT, CNCR, CNRW, CNRF, CNRA, CNRF, CNRB, CNRT, CNCR, CNRW, CNRF, CNRA.

Atlantic or Eastern Daylight Saving Time Stations

CFCA, Toronto, Can. (358.9m-840kc), 8:30 p. m., Clemens Hamilton, vocal; 8:45 p. m., WBBR, New York, N. Y. (272.1m-100kc), 8 p. m., Carl Park, vocalist; 9 p. m., WCAE, Pittsburgh, Pa. (461.5m-690kc), 9:30 p. m., dinner concert; 8 p. m., WBEA; 9 p. m., WBEA; 10 p. m., WBEA; 11 p. m., WBEA.

Eastern Standard or Central Daylight Saving Time Stations

KDKA, Pittsburgh, Pa. (309.1m-870kc), 8:30 p. m., Carl Martin, vocal; 9 p. m., WADC, Akron, Ohio (268.5m-1160kc), 6:30 p. m., dinner concert; 8 p. m., WBEA; 9 p. m., WBEA; 10 p. m., WBEA; 11 p. m., WBEA.

Central Standard Time Stations

KFH, Wichita, Kan. (267.7m-1120kc), 7-8 p. m., Knickerbocker; 7:30-8 p. m., KPNP, Fort Worth, Tex. (283.7m-1140kc), 7 p. m., old-time music; 8-9 p. m., KLSB, Independence, Mo. (449.5m-890kc), 8 p. m., E. N. Brinburn, baritone; 8:30 p. m., KMA, Shenandoah, Va. (252m-1190kc), 9-11 p. m., Delmonico Dancers' orchestra; 9-11 p. m., KPA, Kansas City, Mo. (285.9m-1010kc), 7:30 p. m., Harry Kobusch and his orchestra; 8:30 p. m., WJAZ, Chicago, Ill. (326.9m-810kc), 7-8 p. m., WJAZ; 8:30 p. m., WJAZ.

A. C. Radio forum; 7. William Russell, banjoist; Frances Gattinacci, soprano; Francis G. Loury, pianist; 8. Madame Sophie Archambault, soprano; 8:30. Arthur Clifton, organist; 9:30. Cook's Buttery ball.

GENERAL TALKS AND SPEECHES

Saturday, May 1

Atlantic Eastern Central Mountain Pacific 9 p. m. 7 6 5 4 3 2 1. WRC (468.5m-610kc), "The World of Congress," 10 p. m. WCOO (410.4m-720kc), "Fireside Philosophies," 11 p. m. Rev. Roy L. Smith.

Monday, May 3

Atlantic Eastern Central Mountain Pacific 9 p. m. 7 6 5 4 3 2 1. WDAF (365.6m-820kc), Address, Edgar A. Linton, 10:25-11:25 p. m. WDAF (365.6m-820kc), Address, Edgar A. Linton, 10:25-11:25 p. m. WDAF (365.6m-820kc), Address, Edgar A. Linton, 10:25-11:25 p. m.

Tuesday, May 4

Atlantic Eastern Central Mountain Pacific 9 p. m. 7 6 5 4 3 2 1. WMAQ (447.3m-670kc), Book talk, Harry Hanson, 10:30-11:30 p. m. WMAQ (447.3m-670kc), Book talk, Harry Hanson, 10:30-11:30 p. m. WMAQ (447.3m-670kc), Book talk, Harry Hanson, 10:30-11:30 p. m.

Wednesday, May 5

Atlantic Eastern Central Mountain Pacific 9 p. m. 7 6 5 4 3 2 1. WJAZ (326.9m-810kc), "Wonders of the Sky," 10:10-11:10 p. m. WJAZ (326.9m-810kc), "Wonders of the Sky," 10:10-11:10 p. m. WJAZ (326.9m-810kc), "Wonders of the Sky," 10:10-11:10 p. m.

Thursday, May 6

Atlantic Eastern Central Mountain Pacific 9 p. m. 7 6 5 4 3 2 1. WJAZ (326.9m-810kc), "Wonders of the Sky," 10:10-11:10 p. m. WJAZ (326.9m-810kc), "Wonders of the Sky," 10:10-11:10 p. m. WJAZ (326.9m-810kc), "Wonders of the Sky," 10:10-11:10 p. m.

Friday, May 7

Atlantic Eastern Central Mountain Pacific 9 p. m. 7 6 5 4 3 2 1. WJAZ (326.9m-810kc), "Wonders of the Sky," 10:10-11:10 p. m. WJAZ (326.9m-810kc), "Wonders of the Sky," 10:10-11:10 p. m. WJAZ (326.9m-810kc), "Wonders of the Sky," 10:10-11:10 p. m.

Saturday, May 8

Atlantic Eastern Central Mountain Pacific 9 p. m. 7 6 5 4 3 2 1. WJAZ (326.9m-810kc), "Wonders of the Sky," 10:10-11:10 p. m. WJAZ (326.9m-810kc), "Wonders of the Sky," 10:10-11:10 p. m. WJAZ (326.9m-810kc), "Wonders of the Sky," 10:10-11:10 p. m.

Sunday, May 9

Atlantic Eastern Central Mountain Pacific 9 p. m. 7 6 5 4 3 2 1. WJAZ (326.9m-810kc), "Wonders of the Sky," 10:10-11:10 p. m. WJAZ (326.9m-810kc), "Wonders of the Sky," 10:10-11:10 p. m. WJAZ (326.9m-810kc), "Wonders of the Sky," 10:10-11:10 p. m.

KSO, Clarinda, Iowa (241.8m-1240kc), 7 p. m., Baker and Anderson Harmonium team; 8 p. m., Municipal band; 9 p. m., William M. Hinton, organist; 9:30 p. m., William M. Hinton, organist; 9:30 p. m., William M. Hinton, organist.

Friday, May 7

Headliners Today

Atlantic Eastern Central Mountain Pacific 9 p. m. 7 6 5 4 3 2 1. WJAZ (326.9m-810kc), "Wonders of the Sky," 10:10-11:10 p. m. WJAZ (326.9m-810kc), "Wonders of the Sky," 10:10-11:10 p. m. WJAZ (326.9m-810kc), "Wonders of the Sky," 10:10-11:10 p. m.

Atlantic or Eastern Daylight Saving Time Stations

WCAE, Pittsburgh, Pa. (461.5m-690kc), 9:30 p. m., dinner concert; 8 p. m., WBEA; 9 p. m., WBEA; 10 p. m., WBEA; 11 p. m., WBEA.

Eastern Standard or Central Daylight Saving Time Stations

KDKA, Pittsburgh, Pa. (309.1m-870kc), 8:30 p. m., Carl Martin, vocal; 9 p. m., WADC, Akron, Ohio (268.5m-1160kc), 6:30 p. m., dinner concert; 8 p. m., WBEA; 9 p. m., WBEA; 10 p. m., WBEA; 11 p. m., WBEA.

Central Standard Time Stations

KFH, Wichita, Kan. (267.7m-1120kc), 7-8 p. m., Knickerbocker; 7:30-8 p. m., KPNP, Fort Worth, Tex. (283.7m-1140kc), 7 p. m., old-time music; 8-9 p. m., KLSB, Independence, Mo. (449.5m-890kc), 8 p. m., E. N. Brinburn, baritone; 8:30 p. m., KMA, Shenandoah, Va. (252m-1190kc), 9-11 p. m., Delmonico Dancers' orchestra; 9-11 p. m., KPA, Kansas City, Mo. (285.9m-1010kc), 7:30 p. m., Harry Kobusch and his orchestra; 8:30 p. m., WJAZ, Chicago, Ill. (326.9m-810kc), 7-8 p. m., WJAZ; 8:30 p. m., WJAZ.

Mountain Standard Time Stations

CNRC, Calgary, Can. (483.8m-588kc), 9 p. m., orchestra; 9:30 p. m., WRC (468.5m-610kc), "The World of Congress," 10 p. m. WCOO (410.4m-720kc), "Fireside Philosophies," 11 p. m. Rev. Roy L. Smith.

Pacific Standard Time Stations

KFI, Los Angeles, Calif. (467m-642kc), 7-8 p. m., Greco Synchronizing string ensemble; 7:50-8 p. m. Harris' detective story; 8-9 p. m. program, Ventura Refining company; 9-10 p. m. program, Y. S. Stewart Corp.; 10-11 p. m. program of dance and popular songs.



Sunday, May 9

Synopses; Lola Gill and Mort Demmo and his ukulele; 10. Pasquale Six orchestra. KGO, Oakland, Calif. (261.2m-830kc), 11 a. m., Trinity Episcopal church; 3:30 p. m., vesper; 7:45, Trinity Episcopal church. KGW, Portland, Ore. (491.5m-610kc), 10:45-12 noon, Church of Our Father, Unitarian; 7:30-9, First Presbyterian church; 9-10, chorale symphony orchestra. KFSN, Pasadena, Calif. (315.5m-590kc), 8:45-9:45 p. m., Maryland Artists' ensemble. KTAB, Oakland, Calif. (283.5m-1230kc), 9:45 a. m., Bible lecture; service; 7:45 p. m., service; 9:30-11, concert.

Monday, May 10

Headliners Today

Atlantic Eastern Central Mountain Pacific 8:30 p. m. 8:30 7:30 8:30 8:30 WEAZ (379.5m-700kc), Troy Conservatory of Music. 10 WGR (319m-940kc), Amherst choral club. WBYA (256.5m-1170kc), Tri-City program. 10:15 8:15 8:15 7:15 6:15 WEMC (285.5m-1050kc), Radio Lighthouse Music Makers.

For stations silent tonight refer to first Monday's list.

Atlantic or Eastern Daylight Saving Time Stations

WCAE, Pittsburgh, Pa. (461.3m-650kc), 6:30 p. m., dinner concert; 8, musical; 9, concert; 10, grand opera; 11:35, dance. WCAP, Washington, D. C. (468.5m-640kc), 7-8 p. m., studio program; 9, WEAF; 9-10, WEAF. WCAU, Philadelphia, Pa. (277.5m-1080kc), 7:30 p. m., recital; N. Spellenburg and company; 8, Carolyn Thomas, contralto; The Horn Boys; 9, Merry Melodians; 9:40, Jackson and Ellis, Radio sweethearts; 10, recital.

EDUCATIONAL FEATURES

Table with columns for station, time, and program details. Includes programs like 'Columbia university lecture', 'College of the Air', 'U. of Maryland', 'U. of Pittsburgh', 'U. of Chicago', etc.

WJL, Detroit, Mich. (352.7m-850kc), 8 p. m., dinner concert; 7, studio program; 8, WEAF; 9, Detroit News orchestra. Central Standard Time Stations: KFAB, Lincoln, Neb. (340.7m-880kc), 5:30-6:30 p. m., dinner concert; 8:30-10:30, Ed Ellington, songbird; Harriet Cruise, Oriole of the Air; Master Six orchestra; Horace Boyer. KFJ, Wichita, Kans. (267.7m-1120kc), 7-8 p. m., radio quartet. KFMF, Hattiesburg, Miss. (288.3m-1040kc), 9-11 p. m., W. M. Dutton and Sons. KFMF, Shenandoah, Iowa (263m-1140kc), 7 p. m., 'The program of Paul Jones, Rev. A. Fischer; musical program, bass clarinet. KMA, Shenandoah, Iowa (252m-1150kc), 9-11 p. m., Horace Boyer, Hor. De Boy, Grady and Doe. KOIL, Council Bluffs, Iowa (277.5m-1080kc), 8 p. m., Hugh W. McGinn, Missourian; 9:30, Original Collections; 10:30, Family Men; 9, Ray Winn and his Paramount orchestra; Marie Salisbury, violinist; Olivetta Sillsbury, pianist; Kathryn Schmitt, cellist; 11, Halsey Totley hour. KPRC, Houston, Texas (296.5m-1010kc), 8:30 p. m., Harold Ochs's Warwick hotel orchestra; 7:30, band concert; 8:30, Dr. Eagle J. Shay, tenor. KRO, Clarinda, Iowa (241.8m-1240kc), 7 p. m., Euel McHardy concert. KTNS, Hot Springs National Park, Ark. (374.8m-800kc), 9:30-10 p. m., musical comedy hits, Gene Arlington hotel orchestra; 10-10:30, W. Brown, baritone; 10:30-11:30, organ concert, Lawson Reid. KUOA, Fayetteville, Ark. (299.5m-1090kc), 8 p. m., Lucy Leicht Brown, violinist. WBAF, Fort Worth, Texas (475.9m-630kc), 7:30-8:30 p. m., Knights of Pythias; 8:30-11, Paul Blazer; 11, Duncan-Marlin orchestra; Majestic theater. WCDA, Pensacola, Fla. (222m-1350kc), 7 p. m., Silas's 12th Street Artillery jazz orchestra; Sergeant Silva and his jazzin' concert; band concert. WEMC, Barren Springs, Mich. (285.5m-1050kc), 8:15 p. m., Radio Lighthouse Music Makers; Ruth Lee, soprano; Thurston Madison, violinist. WFAA, Dallas, Texas (475.5m-630kc), 6:30-7:30 p. m., Honey Boys' orchestra; 8:30-9:30, program. WHB, Kansas City, Mo. (365.6m-820kc), 7-8 p. m., Sweeney Radio orchestra; Harry Kessel, soloist; Lola Cook, pianist. WHD, Des Moines, Iowa (526m-570kc), 7:30-9 p. m., Prof. Paul Brew, pianist; Prof. Joseph Gifford, reader; Stewart Watson, baritone; 11-12 midnight, L. Carlos Meyer, organist.

Photograves of Your Favorite Artists GALLERY OF RADIO STARS

SUITABLE FOR FRAMING OR PLACING IN YOUR ALBUM. BY SPECIAL arrangement, Radio Digest is able to offer its readers a great opportunity to secure nine photograves of their favorite Radio stars at practically no cost. Radio fans will be able now, by this very special offer, to have pictures of their favorite artists and announcers before them when they listen in. All that is necessary to secure photograves from the Gallery of Radio Stars is to send the coupon published each week in Radio Digest, accompanied by ten cents to cover the cost of mailing and postage. Where a series of three photograves is desired, it will only be necessary to send twenty-five cents and three consecutively numbered coupons clipped from Radio Digest. Remittance must accompany the coupon. Cash at your risk. Add 5 cents to personal checks for exchange.

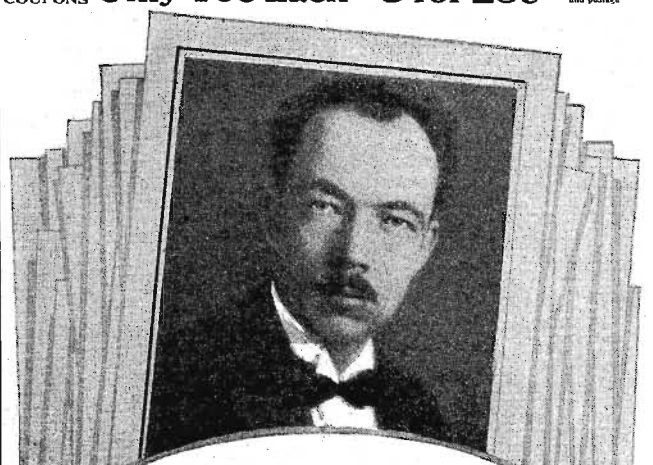

NORMAN BROKESHIRE Popular from WRC and WJZ

THESE PICTURES ARE 11 x 14 INCHES

Select Your Favorites from the Gallery of Radio Stars

- 1 Wendell Hall, king of ukulele ditties
2 Graham McNamee, 1925 Gold Cup announcer
3 Jack Little, popular wandering balladist
4 Billy E. Van, the Sunshine Man
5 Coon-Sanders' "Nighthawks" at KYW
6 George Hay, 1924 Gold Cup announcer
7 Harmony Girls, Edith Carpenter, Grace Ingram
8 Ford and Glenn, Lullaby Boys of WLS
9 "Roxy" Rothafel of WEAF chain fame
10 The Hired Hand, famous "Substitute Announcer" of WBAF
11 Bob Emery, Big Brother of WEEL
12 "Bill" W. G. Hay, ex-KFKX, known of WLB
13 Happiness Boys, jovial singers of WEAF
14 Lambdin Kay, "Little Colonel" of WSB
15 Leo Fitzpatrick, "Merry Old Chief," WJR
16 Henry Field, 1925 Gold Cup runner-up
17 Al Carney, organ favorite at WHT
18 Vincent Lopez, No. 1 Pennsylvania orchestra
19 Iris Ruth Favey, KOA's invisible stage beauty
20 E. L. Tyson, pleasing voice at WJZ
21 Art Gilliam, "The Whispering Pianist"
22 Harry Ehrhart, "Dream Daddy" of WLIT
23 Correll and Gosden of "Kinky Kids Parade" fame, at WEBB and other stations.
24 Norman Brokenshire, popular at WRC, WJZ
25 Jane Novak, Blues Singer of Twin Cities, WCCO
26 Jean Sargent, the original, now at WHT
27 Ralph Emerson, popular organist at WLS
28 Edna Adams, of KPRC
29 Pat Barnes, vaudeville announcer at WHT
30 Walter Wilson, "Uncle Bob" of KYW
31 Ray-O-Vac Twins, known country-wide
32 Art Linkin, KYW's Mrs. Schlegelhauser
33 Fred Hamm of WTAS, now WLB, fame
34 Meyer Davis' Le Paradis orchestra of WRC
35 D. R. P. Coats, 1925 Silver Cup announcer
36 Gene Rouse, WOAW's popular announcer
37 Iris Ruth Favey, KOA's invisible stage beauty
38 Ipana Troubadours, on the WEAF Chain.

Have the Pictures of These Stars Send Coupon Now

Your radio set gives you these voices. These pictures add very much to your complete entertainment. ACT TODAY

COUPON NO. 19. This coupon entitles the holder to one photograve selected from the Radio Digest Gallery of Radio Stars when accompanied by ten cents to pay the cost of mailing and postage. Three consecutively numbered coupons entitle the holder to three photograves when accompanied by 25 cents. Remittance must accompany the coupon. Cash at your risk. Add 5 cents to personal checks for exchange. Order by Number: RADIO DIGEST PUBLISHING CO. 510 N. Dearborn St. Chicago, Ill.

Tuesday, May 11

Eastern Standard or Central Daylight Saving Time Stations

KDKA, Pittsburgh, Pa. (309.1m-970kc), 9 p. m., Road Light Opera Hour. WABQ, Haverford, Pa. (261m-1150kc), 11 p. m., Ardmore theater program. WGB, Clearwater, Fla. (265.3m-1130kc), 8:30-10 p. m., diversified program, Mrs. Paul Delemeter; L. Joy, pianist. WHAZ, Troy, N. Y. (379.5m-790kc), 8:30 p. m., concert, Troy Conservatory of Music; 9:30, dance orchestra. WLW, Cincinnati, Ohio (422.2m-710kc), 7 p. m., community orchestra; 8, Crowley Little symphony orchestra; male quartet; 10, Henry Trust's orchestra. WOO, Grand Rapids, Mich. (241.8m-1240kc), 9-10 p. m., classical concert; 10-11, "The Key to the Door"; 11-12 midnight, "17th Wagonite". WSAI, Cincinnati, Ohio (383.5m-820kc), 10-12 midnight, musical. WTAM, Cleveland, Ohio (380.4m-770kc), 8:30 p. m., dinner hour; 9, music and his Hot Hot Hot orchestra; 8-11, Cleveland's city band, artists; 11-12 midnight, Austin Wyler's orchestra; 12-1, popular songs; 2 a. m., Guy Lombardo and his Royal Canadiana dance orchestra.

Headliners Today

Atlantic Eastern Central Mountain Pacific 9 p. m. 9 7 6 5 KFKX (285m-1140kc), Hawaiian music. 9:30 8:30 7:30 8:30 5:30 KDKA (309.1m-970kc), Oratorical program. 10 KOIL (277.5m-1080kc), Bohemian music. 6 WGN (302.5m-990kc), "Peer Grot". 7 WWSB (365.6m-820kc), Stetson concert. 10:30 10 9 8 WSM (282.5m-1060kc), Dance frolic.

For stations silent tonight refer to first Tuesday's list.

Atlantic or Eastern Daylight Saving Time Stations

WCAE, Pittsburgh, Pa. (461.3m-650kc), 8:30 p. m., dinner concert; 9-11, WEAF; 10, WEAF; 11:45, Red Hot theater. WCAU, Philadelphia, Pa. (277.5m-1080kc), 7:30 p. m., soulful instrumental trio; 8, theater digest; Ana Lipchitz; 8:10, The Three Brothers; 8:45, popular songs; 9, Robert Frazer, blind gospel singer; 9:30,

Tuesday, May 11

Esther Lawrence and her Players; 10, Eddie Mallo and Danny Douglas, popular song; 10:30, Billy Hayes and his Cathy Tea Garden dance orchestra. WEAF, New York, N. Y. (491.5m-610kc), 4-12 midnight, Vincent Lombardi and his orchestra; 4-12, Vincent Lombardi and his orchestra; 4-12, Vincent Lombardi and his orchestra; 4-12, Vincent Lombardi and his orchestra.

Eastern Standard or Central Daylight Saving Time Stations

KDKA, Pittsburgh, Pa. (309.1m-570kc), 5:30 p. m., KDKA Little Symphony orchestra; 8:30, orchestra evening; 10:30, KDKA Little Symphony orchestra; 11:30, concert, Grand theater. WBBM, Chicago, Ill. (225.4m-430kc), 8-9:30 p. m., Alvinne orchestra; 9:30-10, Miss Covered Melodist; 10-11, Harmonious Aids; 11-12 midnight, dance revival.

WMAQ, Chicago, Ill. (447.5m-870kc), 8 p. m., organ; 8:30, Sheets Hotel LaSalle orchestra; 9:30, program; 9:55, chimes. WOOD, Grand Rapids, Mich. (241.8m-1240kc), 9-11 p. m., Henry Ford Old Time dance. WQJ, Chicago, Ill. (447.5m-870kc), 7-8 p. m., dinner concert; 10-11 a. m., Radio Skybirds; Rose Vanderbosch; Everett George Orle, vocalist; Jia Shannanbeck, soprano; Will Rosstler; Toll Taylor; Johnny Post; 1-2, Glinger hour.

Central Standard Time Stations

KFAB, Lincoln, Neb. (340.7m-890kc), 5:30-6:30 p. m., dinner concert; 8:30-10:30, University of Nebraska. KFDM, Beaumont, Texas (315.8m-950kc), 8-9 p. m., Magnolia Petroleum company's Refinery orchestra; 9-10, Southern Ramblers orchestra. KFH, Wichita, Kans. (267.2m-1120kc), 7-8 p. m., Gaze Brewers Hawaiians.

KTHS, Hot Springs National Park, Ark. (374.8m-800kc), 9-10-11 p. m., piano concert; New Arlington hotel orchestra; 10:30-10:45, Violet Beldine, vocal solo; Elizabeth Bove, accompanist. KUSA, Fort Collins, Ark. (299.8m-1000kc), 8 p. m., Harry E. Schultz, baritone; University glee club quartet. KYW, Chicago, Ill. (535.4m-560kc), 5:30-6 p. m., dinner concert; 6-7, American studio; 7:30-8, Congress hotel; 9-9:30, classical concert; 9:30-10:30, Congress concert.

Pacific Standard Time Stations

KFI, Los Angeles, Calif. (407m-642kc), 3:30 p. m., program; Charles Remschlager; 8:30, Vardan Noel Belmont, baritone; 7, Jack Rinehart's Chinese Garden orchestra; 7:30, Evelyn Ford; 8, Seven artists quartet; 9, Spanish music; Olga Stofant, Angeline trio; 10, Packard Radio club. KGO, Oakland, Calif. (361.2m-830kc), 8-9 p. m., Erregault program; "Joplin on the Radio," vaudeville, Fred; 10-12 midnight, dance music.

Wednesday, May 12

Headliners Today

Table with 5 columns: Atlantic, Eastern, Central, Mountain, Pacific. Lists radio stations and their programs for Wednesday, May 12.

For stations silent tonight refer to first Wednesday's list.

Atlantic or Eastern Daylight Saving Time Stations

WCAE, Pittsburgh, Pa. (401.3m-650kc), 6:30 p. m., dinner concert; 8-9, WKAT; 9, Kramer's orchestra; 10, WKAT. WDAU, Philadelphia, Pa. (277.6m-1060kc), 7:30 p. m., recital; N. Snelberger and company; 8:10, Joe Murphy; 8:30, Clarence Newman and his Penna/Vanna concert orchestra; 9, recital; 9:25, Ruppert and McCullough, baritone; 10:30, Carl Taylor and Lea Herscher, popular songs; 10:45, Frank Cook, old-time songs; 11, Arthur Billions's Clear-Up club.

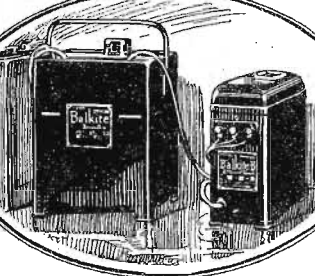

Noiseless - full radio power from the light socket with Balkite "B" and Balkite Battery Charger

Noiseless, full, reliable radio power. It is absolutely essential to good reception. With Balkite "B" and the Balkite Battery Charger you can have this power, always, whenever you need it, from the light socket. Balkite "B" at \$35\* is unlike any other "B" device. It replaces your "B" batteries and supplies plate current from the light socket. It is entirely noiseless. It does not require replacements and will not deteriorate with use. It will outlive 20 sets of "B" batteries. To our knowledge not one has ever worn out. It is tested and listed as standard by the Underwriters' Laboratories.

It is absolutely guaranteed to give satisfaction. Today over 75,000 Balkite "B's" are giving satisfactory service on all types of receiving sets. The popular high-rate Balkite Battery Charger at \$19.50\* is absolute insurance against weak "A" batteries. Because it is entirely noiseless it can be used while the set is in operation. If your battery should be low you merely turn on the charger and operate the set. Add these two permanent Balkite Radio Power Units to your set now. Thereafter you need never again worry about your power supply. Ask your dealer.

\*Prices slightly higher West of Rockies and in Canada

FAN STEEL Balkite Radio Power Units

Manufactured by FANSTEEL PRODUCTS COMPANY, Inc., North Chicago, Ill.

REASONS Why Dr. Owen's Specified JEFFERSON AL Sealed Transformers

Dr. Owen of Oklahoma University selected the Jefferson A L Sealed Transformer for his new super-torodyne circuit, described in Radio Digest, for the following reasons:

- 1 Nicety of balance, giving even amplification at low frequencies, and preventing resonant peaks at the higher frequencies. 2 Tests show a practically straight line curve from 30 cycles for the low notes up to 10,000 for the high. 3 Heavy insulation throughout, lowering resistance between the primary and core. 4 Can be used with the new power tubes. 5 This transformer is SEALED IN A METAL CASE, insuring protection against moisture and other outside influences.

Ratio: 2 to 1; price \$6. Sold by leading dealers. If your dealer does not have Jefferson A L Transformers in stock, do not be satisfied with a substitute, but write us direct.

Jefferson Electric Mfg. Co. 506 S. Green St., Chicago, Ill. Specialists in Electrical Precision Equipment

Wednesday, May 12

WJZ, New York, N. Y. (454.3m-800kc), 8 p. m., Imperial Jungs; 9:30, Louisiana free accordion music; 10:45, George Olsen's Pennsylvania artil concert orchestra...

Eastern Standard or Central Daylight Saving Time Stations

KDKA, Pittsburgh, Pa. (309.1m-970kc), 8:30 p. m., concert; WGBM, Chicago, Ill. (225.4m-1330kc), 8-10 p. m., popular period; 12-2 a. m., Almetie orchestra...

Thursday, May 13

Headliners Today

Atlantic Eastern Central Mountain Pacific 9 p. m. WVF (508.2m-800kc), Scandinavian chorus. KCTCS (374.9m-800kc), Traditional Jewish chorus...

For stations silent tonight refer to first Thursday's list.

FARMERS' PROGRAMS INDEX

Farmer Dinner Concerts

Daily Except Sunday

CENTRAL TIME KPMP, 12:15-1:35 p. m. KMLA, 1:30-1:50 p. m. KSO, 12:30-1:30 p. m.

Table with columns: Atlantic, Eastern, Central, Mountain, Pacific. Rows for Saturday, May 1 and Sunday, May 2.

Table with columns: Atlantic, Eastern, Central, Mountain, Pacific. Rows for Monday, May 3 and Tuesday, May 4.

Table with columns: Atlantic, Eastern, Central, Mountain, Pacific. Rows for Wednesday, May 5 and Thursday, May 6.

Table with columns: Atlantic, Eastern, Central, Mountain, Pacific. Rows for Friday, May 7 and Saturday, May 8.

Table with columns: Atlantic, Eastern, Central, Mountain, Pacific. Rows for Sunday, May 9 and Monday, May 10.

Table with columns: Atlantic, Eastern, Central, Mountain, Pacific. Rows for Tuesday, May 11 and Wednesday, May 12.

Table with columns: Atlantic, Eastern, Central, Mountain, Pacific. Rows for Thursday, May 13 and Friday, May 14.

Table with columns: Atlantic, Eastern, Central, Mountain, Pacific. Rows for Saturday, May 15 and Sunday, May 16.

Table with columns: Atlantic, Eastern, Central, Mountain, Pacific. Rows for Monday, May 17 and Tuesday, May 18.

Table with columns: Atlantic, Eastern, Central, Mountain, Pacific. Rows for Wednesday, May 19 and Thursday, May 20.

Atlantic or Eastern Daylight Saving Time Stations

WCAE, Pittsburgh, Pa. (481.3m-850kc), 6:30 p. m., dinner concert; WCAU, Philadelphia, Pa. (277.6m-1080kc), 6:30 p. m., Kelly Grayson and orchestra...

Central Standard Time Stations

KDKA, Pittsburgh, Pa. (309.1m-970kc), 8:30 p. m., half hour with famous composers; WGBM, Chicago, Ill. (225.4m-1330kc), 8-10 p. m., popular music...

Eastern Standard or Central Daylight Saving Time Stations

WGBM, Chicago, Ill. (225.4m-1330kc), 8-10 p. m., popular music; KDKA, Pittsburgh, Pa. (309.1m-970kc), 8:30 p. m., half hour with famous composers...

Central Standard Time Stations

KFM, Wichita, Kan. (267.7m-1120kc), 7-8 p. m., American Legion quartet; WCAE, Pittsburgh, Pa. (481.3m-850kc), 6:30 p. m., dinner concert...

Mountain Standard Time Stations

KFAA, Dallas, Tex. (475.9m-850kc), 7:30-7:50 p. m., Jimmy Joy's orchestra; WCAE, Pittsburgh, Pa. (481.3m-850kc), 6:30 p. m., dinner concert...

Pacific Standard Time Stations

KFI, Los Angeles, Calif. (467.7m-642kc), 5:30 p. m., madrigal program; KGO, Oakland, Calif. (661.2m-830kc), 8 p. m., organ recital...

Mountain Standard Time Stations

KFAA, Dallas, Tex. (475.9m-850kc), 7:30-7:50 p. m., Jimmy Joy's orchestra; WCAE, Pittsburgh, Pa. (481.3m-850kc), 6:30 p. m., dinner concert...

Pacific Standard Time Stations

KFI, Los Angeles, Calif. (467.7m-642kc), 5:30 p. m., madrigal program; KGO, Oakland, Calif. (661.2m-830kc), 8 p. m., organ recital...

Friday, May 14

Headliners Today

Atlantic Eastern Central Mountain Pacific 9:30 a. m. WRO (528m-570kc), Sigma Alpha Iota sorority; WGR (318m-840kc), Etude trio...

For stations silent tonight refer to first Friday's list.

Atlantic or Eastern Daylight Saving Time Stations

WCAE, Pittsburgh, Pa. (481.3m-850kc), 6:30 p. m., dinner concert; WCAU, Philadelphia, Pa. (277.6m-1080kc), 6:30 p. m., Kelly Grayson and orchestra...



CLASSICAL CONCERTS INDEX

Table with columns for day (Saturday, Wednesday) and region (Atlantic, Eastern, Central, Mountain, Pacific). Lists radio stations and their broadcast times.

Table with columns for day (Sunday) and region (Atlantic, Eastern, Central, Mountain, Pacific). Lists radio stations and their broadcast times.

Table with columns for day (Monday) and region (Atlantic, Eastern, Central, Mountain, Pacific). Lists radio stations and their broadcast times.

Table with columns for day (Tuesday) and region (Atlantic, Eastern, Central, Mountain, Pacific). Lists radio stations and their broadcast times.

Friday, May 14

WCAU, Philadelphia, Pa. (277.6m-1080kc), 6:45 p. m., Clarence Sommer and his Pennsylvania hotel orchestra; 7:30, Suedenborg instrumental trio; 8, recital; 8:15, symphonic talk; 8:30, The Singing Gravel; 8:45, The Royal Girl; 9, The Italian Creamers; 9:15, Dvornik Stravinsky, pianist; 9:30, Alcega's music; 10, Archie Lloyd, songs; 10:30, Jack Jany's musical sketches.

Benjamin Franklin concert orchestra; 7, Uncle Wain's lecture series; WJAR, Providence, R. I. (305.9m-930kc), 8 p. m., musical; 8:30, WEAF; 9, music; 10, WEAF; 11, Providence-Biltmore dance orchestra; WIZ, New York, N. Y. (454.3m-680kc), 7 p. m., Hotel Commodore concert orchestra; 8, Spaulding Shere scenes; 8:30, Bonnie Laddies; 9, Baldwin hotel, WCX; 10:30, Hotel Lorraine Grill orchestra; WLIT, Philadelphia, Pa. (394.5m-750kc), 8:10 p. m., Aradia cafe concert orchestra; 8, Schickering hour; 10, Morning Glory club concert; Aradia cafe dance orchestra; 10:30, Rufus and Rufus; 11, Freshman Marching Band; 12 midnight, Morning Glory concert; WDD, Philadelphia, Pa. (308.2m-590kc), 7:30 p. m., Rita Carlton dance orchestra; 8, recital; 9:30, Fox theater orchestra; 10, WEAF; 10:30, Sylvania dance orchestra.

Eastern Standard or Central Daylight Saving Time Stations

KDKA, Pittsburgh, Pa. (309.1m-570kc), 6:30 p. m., dance concert; 9, concert; WABQ, Haverford, Pa. (261m-1130kc), 11 p. m., Horace Butler, organist; William Stewart, pianist; WBBM, Chicago, Ill. (225.4m-1200kc), 8-10 p. m., Godelle Genter, violinist; Basger quartet; WEAF, Washington, D. C. (488.5m-640kc), 6-8:30 p. m., Mozart string quartet; 8:45-9, playlet, features; 9:30, WEAF; 9:30-10, studio program; 10-12 midnight, music, Wardman Park hotel.

WEDH, Chicago, Ill. (370.2m-610kc), 7 p. m., Oberon's orchestra; Bernard Weber, Pauline Sachs; 9:15, Osborn's orchestra; Bernard Weber; 11-12:30 a. m., Orpheus orchestra; Frank Braxator; The Young Knickerbocker; WGH, Clearwater, Fla. (265.3m-1130kc), 8:30-10 p. m., diversified program; old-time duet, Mr. and Mrs. Charles Wilson; WGN, Chicago, Ill. (302.9m-800kc), 6:45-6:55 p. m., musical program; 8:55-9:15, Drake concert ensemble; Blue-toned string quintet, concert program; 9:30-9:55, musical program; 9:55-10, WEAF; 9:58-10, Phantom violin; 10-10:10, Sam H. Kemp; 10:40-10:50, musical program; 10:50-11:15, the play about; 10:40-11:15, musical program, ensemble; WHT, Chicago, Ill. (389.8m-750kc), 7 p. m., Al Carver, organist; Helen Roth, pianist; 7:50, Ray-O-Vac concert; 8:45-10:15 (258m-1260kc), Cincinnati cafe orchestra; 10:30 (299.8m-700kc), Sunbeam Girls; 11:05, Lofts ball-hall presentation; 12 midnight, your hour lesson; WISD, Chicago, Ill. (225.4m-1330kc), 6-8 p. m., Elsie Orr, soprano; Ray McKay; WIBO string trio; 10-2 a. m., popular program; WJAZ, Chicago, Ill. (329.3m-910kc), 9-1 a. m., dance program, Club Chez Pierre; Earl Hoffman orchestra; Pierre revue; WJZ, Moosehart, Ill. (370.2m-610kc), 8-9 p. m., music by children; 10-11, Senator Harold C. Kessinger; Palmer House Victrolas; 12:30, setting up hour; WLID, Chicago, Ill. (302.9m-800kc), 7:15-7:30 p. m., The Millionaire; 7:50-8:30, Old Fashioned Almanack; 7:30-8, Drake concert ensemble; 11-11:20, songs, Charles and Gordon; 11:20-11:45 a. m., concert; Charles Strait's Rendezvous cafe orchestra, Drake hotel concert orchestra; WLS, Chicago, Ill. (344.6m-870kc), 7:15-12 midnight, national ball dance; WMAQ, Chicago, Ill. (447.5m-670kc), 6 p. m., organ; 8:30, to be announced; WOOD, Grand Rapids, Mich. (241.8m-1240kc), 9:15-10 p. m., classical program; 10-11, Home college; WRVA, Richmond, Va. (250.3m-1170kc), 7 p. m., Hotel Richmond orchestra; 8:30, Neapolitan night; 10:30-11:30, Hotel Richmond Garden orchestra; WSW, Chicago, Ill. (275.8m-1090kc), 8 p. m., Terrace Garden orchestra; 10, Terrace Garden Play; Sky-lark male quartet; WTAM, Cleveland, Ohio (389.4m-770kc), 6-7 p. m., Carl Rupp and his Hotel Hollenden orchestra; WTIC, Hartford, Conn. (475.8m-630kc), 7:45-8 p. m., program, American Legion; 9:45, WTIC Mail box; 10, Emil Baumgardner's Hotel Bond dance orchestra; WWC, Detroit, Mich. (352.7m-850kc), 6 p. m., dinner concert; 8, Detroit News orchestra; 9, WEAF; 9:30, dance program.

Central Standard Time Stations

KFDM, Beaumont, Tex. (315.6m-950kc), 8-10 p. m., Marcella Petropoulos company's band; W. W. Wichita, Kan. (267.7m-1200kc), 7-8 p. m., Gold Medal Krackers; KFKX, Hastings, Neb. (288.3m-1040kc), 9-11 p. m., piano organ concert; KFNB, Shenandoah, Iowa (263m-1140kc), 7:30 p. m., pipe organ concert; KFUB, St. Louis, Mo. (545.1m-550kc), 9:30 p. m., "The Last Journey to and Entrance into Jerusalem"; R. Coomer, pianist; KMA, Shenandoah, Iowa (252m-1190kc), 9-11 p. m., popular musical program; WHL, Council Bluffs, Iowa (277.6m-1080kc), 6 p. m., Jack and Jill; 6:35, Royal Fontenelle orchestra; 7:33, Grace Pool Steinhilber, soprano; 8:30, Drescher Brothers orchestra; 11, Hazy Topsy hour; KTHS, Hot Springs National Park, Ark. (374.8m-900kc), 9:30-10 p. m., New Ardmore hotel Meyer Davis string quartet; 10-11, Hotel hour, Rutnow Garden; KYW, Chicago, Ill. (535.4m-680kc), 6-7 p. m., musical program; Hotel Congress hotel; 8-9:30, classical concert; 9:30-10:30, carnival; WBAP, Fort Worth, Tex. (475.9m-630kc), 7:30-8:30 p. m., Texa Women's concert; 9:30-11, Post Office band; 11, Panther Hanstun trio; WEMC, Berlin Springs, Mich. (285.5m-1050kc), 9 p. m.,

light-house choir; Rhia Yeater, cellist; Matland All-road, tenor; 9:45, Percy Augustine, tenor; WFAA, Dallas, Tex. (475.9m-630kc), 6:30-7:30 p. m., Foxtrusters orchestra; 8:30-9:30, Priest family recital; WDFB, Evansville, Ind. (236.1m-1270kc), 7 p. m., A. L. McClure, pianist; S. Knoxville college musical program; WHAS, Louisville, Ky. (389.8m-750kc), 7:30-9 p. m., concert, Louisville Music and Radio company; WHB, Kansas City, Mo. (385.6m-820kc), 7-8 p. m., Sweney Radio orchestra; Bert Bender, soloist; Zelma Jaddock, pianist; WHO, Des Moines, Iowa (526m-570kc), 7:30-9 p. m., Sigma Alpha Iota national musical society; 11-12 midnight, Philbrick and his Youcker tea room orchestra; WOAI, San Antonio, Tex. (394.5m-780kc), 8:30 p. m., News and Express and college of music program; WOAW, Omaha, Neb. (326m-570kc), 6:30 p. m., Gilbert Jeffy, violinist; Larry Bradford, pianist; 9 program; 10:30, Frank Hudch and his Nightingale orchestra; WOJ, Chicago, Ill. (447.5m-670kc), 7-8 p. m., dinner concert; 10-11 a. m., Rainie Skylark; Dr. H. Lucille Louie; Harold Olson; Clark's Hawaiian trio; Johnny Post; Ted Taylor; 1-2, Ginger hour; WSM, Nashville, Tenn. (282.8m-1060kc), 7 p. m., Bassey Smith's orchestra; 8, program, Mrs. L. L. Garble; 10, David Lathrop college concert.

Mountain Standard Time Stations

KOB, Salt Lake City, U. S. (348.6m-860kc), 7:30-8:30 p. m., musical program, Mrs. Whalen, director.

Pacific Standard Time Stations

KFI, Los Angeles, Calif. (467m-642kc), 5:30 p. m., program, Eucena Biscailuz; 6:30, Carlisle Stevenson's orchestra; 7:30, Felipe Delgado and Edna Clark Miller; 8, Elliott organ recital; 9, William MacDonnell, Scotch singer; 9:30, musical program, Jeko Kimmel; 10:30, musical program; 11:30, Emma Kimmel, Fat O'Neal, Kray Arousalis, Ashley Sisters; KGO, Oakland, Calif. (381.2m-830kc), 8 p. m., Mills college annual dinner; KGW, Portland, Ore. (491.5m-610kc), 6-7 p. m., dinner concert; 8-9, concert, vocal and instrumental; 9:10-10, concert; 10:30-12 midnight, folkie, Keop Growing Wiser Center of West Oaks; Famous stars, features; KOAC, Corvallis, Ore. (280.2m-1070kc), 7:20 p. m., Arthur Kipphan, tenor; 8-9, musical program; KTAB, Oakland, Calif. (339.9m-1290kc), 8-10 p. m., Brewer's; KWSC, Pullman, Wash. (348.6m-680kc), 7:15 p. m., program, Wabna club of Asotic.

Theater Installs Ear Phones For Slightly Deaf Patrons

LONDON, Eng.—In order that theatergoers who are slightly deaf may not miss any of the fun in "The Farmer's Wife," London's most popular play, now in its third year at the Court theater, a novel Radio scheme has been introduced by the management. "Lorgnette" head phones, or more correctly ear phones, have been installed in certain parts of the dress circle and stalls, so that members of the audience who are a little hard of hearing will not have their enjoyment lessened through missing some of the best points.

Advertisement for 'The Radio Book' featuring an illustration of a radio receiver and the text: 'The Radio Book How to understand radio, assemble circuits, receive reception, operate sets, and is your Radio reference book.'

Advertisement for Crosley Radio: 'All the stories you hear of cost-savings by home-assembly of radios, no more than approximate the economies effected by Crosley methods of mass-production. Imagine, for example, a five-tube set of rare tonal quality, fine sensitivity, superb volume and exquisite beauty for \$75! That is the price of the new Crosley 5-tube RFL... without accessories West of the Rockies, add 10% to all prices THE CROSLY RADIO CORPORATION, Powell Crosley, Jr., Pres. Cincinnati, Ohio CROSLY RADIO BETTER COSTS LESS'

Mail Coupon Today: RADIO DIGEST, 510 N. Dearborn Street, Chicago, Illinois. Enclosed find \$3.00 for one year's subscription to Radio Digest. The new Radio Book, "Radio Receivers," will be mailed FREE, postpaid. This offer only good on subscriptions sent directly to this office, not through agents or agencies. Name: Address: City: State: 5-1-26

## SOUTH AFRICA SHOW GETS U. S. PROGRAM

MESSAGE IS ALSO HEARD BY AUSTRALIAN FAN

2XAF, Schenectady, and Johannesburg Experimenter Successfully Arrange Broadcast Relay

SCHENECTADY—2XAF and Grant Dalton, an enterprising South African experimenter, have demonstrated that it is possible to schedule an 8,050-mile Radio broadcast relay and make good on the program. It came about this way.

The annual agricultural show of the South African Union was held recently in Johannesburg. The show management believed that it would be a fitting climax to the week to give the visitors an opportunity to hear a Radio program from the United States. Cables were exchanged with the General Electric company and a definite time was fixed for the broadcasting, 4 to 6 p. m. Eastern time on the Saturday night show was to close.

William M. Jardine, United States secretary of agriculture, prepared a greeting and other American agricultural leaders sent messages. There were also musical numbers and all were sent out on the 32.79-meter wave of 2XAF, from the studio of WGY here.

### Even Australia Tunes In

South Africa reported by cable that the relay was a great success and then a few hours later, sifting through amateur channels, came a message from E. H. Cox, of Elsternwick, Victoria, Australia, to the effect that he had heard the whole program of 2XAF as late as 7 o'clock in the morning. Johannesburg got the program at about midnight.

South Africans cabled: "Much obliged your cooperation. Special program relayed Sunday a great success. Express our thanks to participants. South African agriculturists reciprocate wishes. Transmitting your Sunday morning dinner music."

### Australian 14,000 Miles Away

The Australian, Mr. Cox (3BD), reported as follows: "Your concert to South Africa heard very loud here three hours after sunrise. Signal would travel eastward from you so distance would be 14,000 miles. Congratulations. Do you ever use 32-meter phone about 4 a. m. Eastern Standard time? Heard phone as late as 7 a. m. and carrier came through as late as 8 a. m."

2XAF is a little brother of the 50-kilowatt transmitter of WGY. It is one of six Radio transmitters on the 54-acre Radio laboratory of the General Electric company. The aerial is only 50 feet long and about the diameter of a lead pencil. 2XAF uses 10,000 watts of power.

### Copyrights Busy Overseas

LONDON.—The initiative has been taken by the authors and dramatists of the Intellectual Cooperative society, which has just held a meeting in Paris under the presidency of M. Luchaire, director of the International Institute of Intellectual Cooperation, with the object of safeguarding the interests of artistic and literary property throughout the world.

## Reader's Views

### Wanna Learn Something?

In April 3 issue of Radio Digest I see that H. W. H. of Vandalla, Mo., thinks that listening in on a program of Station WOVW with a 3-tube set is such a wonderful feat. I, for one, do not think so. I have a 1-tube single circuit regenerative set.

On Friday, March 26, 1926, I listened in on Station KFIU, Juneau, Alaska, wave length 226 meters, power 10 watts. The distance is about 950 miles, air line. We had two head phones on the set, which were in use by my father and I. I will put anybody wise to the trick of receiving low power stations that will drop me a line, especially J. M. H. of Lake Charles, La.—John E. Heuer, Box 179, Trochu, Alberta, Canada.

### Everybody Satisfied

I am of the same opinion as most B. C. L. At each intermission I think the number just played and the one to be played should be announced. For instance, this morning on KMA's early program, the announcer told that a certain selection would be played on the piano and when it was finished, he announced again what it was, then who played it and what the next number would be.

The way he announced gave those late tuning in a chance to know what they had just heard and by whom. If all would do this, I think the majority of B. C. L.'s would be better satisfied.—C.C.F., Howe, Nebr.

### Pleases Individual Only

Don't you think it about time the broadcasting of listeners' congratulations to Radio performers was stopped? It seems to me perfectly all right for listeners to write, telegraph or telephone their approval of the programs to the broadcasting stations, but who wants to have half the evening taken up with announcing that Bill Jones' Superodex is working fine, and Cy Prime's one-tube Vox Populi is getting it clear as a bell? Of course everyone knows that such people simply want to hear their names broadcast. It is getting to be a regular nuisance, I imagine, to everyone except the individual who is waiting to hear his name heralded through the air.—J.A.B., Colorado Springs, Colo.

### Just What It Means

I would like to voice my opinion on some of the letters in your Reader's View column.

If T.H., Okemah, Okla., had used a good standard dictionary he would have found out that "just" means "very lately, a moment ago," which surely justifies the way in which the announcers use it.

Also, what about someone with a new set who possibly hasn't heard a piece of music 150 times?

As to announcer giving a brief description of some of the classic music, I think it makes a piece much more interesting.

### A "RADEX" Tuning Chart

Shows by dial numbers, wave length to which set is tuned. Tells where to place dials for any station. Identifies programs received without announcement.

Adapted to any set  
Send 25c Stamps  
RADEX, Box 143-S, CLEVELAND, O.



### Interference Eliminator

Tunes out that troublesome, powerful station. Brings in stations you never had before. 500,000 actually sold. Radio owners proved to themselves on our free trial that this marvelous instrument fills every claim. Try one at our risk. Learn how much interference you have called station—absorbs some static, too.

Improves Any Set—Tubo or crystal kind of aerial except loop antenna.

Select Stations—Every radio needs

At Will—this Eliminator (Patents Pending). Accept no substitutes—look for the name STEINKITE. No extra tubes or batteries—no tools needed. No change in fee. Just attach to aerial—full instructions given.

Postpaid. Absolutely guaranteed. Money back if not delighted. Two big Banks tell you we are reliable. ORDER TODAY—Dial Bill will file. Free catalog of all Steinkite Products on request.

STEINKITE LABORATORIES  
61 Radio Bldg., Atchison, Kans.

In short, I think there is great improvement to be made in broadcasting, but not much will come from some of these cheap critics. I believe a decent letter to the station telling them what you like and don't like would bring better results. J.H.L., Lansing, Ia.

### Plea for Fairness

During the past year, Radio has gone from bad to worse; at least, that is my opinion, due to the fact that the average listener is constantly criticizing the broadcasters.

There are many cases to cite, but I know of one particular case where a certain party listened from 7 until 11:30 p. m., and was well satisfied. But at 11:35 the station announced an SOS at sea and shut down. The next day, a letter was speeding to them with all sorts of complaints against them, although the sender knew that SOS was the reason.

When people can get as mean as that I think they are the lowest type of humanity—sitting around a cozy fire and having no cause for alarm, while perhaps a hundred people at sea are relying on those few letters, SOS, for life itself, perhaps half frozen in the waters, men, women and children alike. I believe every good American citizen should be willing to shut off his or her set for a few minutes and even offer a prayer for the sake of the unfortunates.

I hope some of you other fans will take up the cause and make plain just what an SOS at sea means. A.F., Cedar Rapids, Nebr.

### Poor Business

Concerning this business about announcer's not doing their work right:

Being an ardent worshipper of the great god, DX, I have had, of course, occasion many times to tune in stations where an announcer would not so much as offer the slightest clue as to the identity of the station. I think that such a habit or custom, or whatever it may be called, is not boosting a station, but is bringing upon it the ire of many Radio fans. It seems that every station would like to be on the right side of its listeners, but certainly the manager of a station that so closely hides its identity is not going about this affair in the right manner.

It's discouraging to listen to a station which might be far off without hearing

where the station is. O.W.T., Baldwinville, Mass.

### Permanent Test Period

Why wouldn't it be a good plan to have a permanent test period in the United States, devoting a short time on a certain day each week for this purpose, the time, if not the day, to be different in each time zone? Only call letters and location should be broadcast during this period, a la CZE, or if music, only a few bars at a time. A few stations could start the ball rolling, if necessary requesting other stations who follow suit to observe the same hour.—A.F.D., Baltimore, Md.

### He's Laughing at You

Everytime I buy a new Radio Digest I get an awful laugh out of these wonderful tuners who pull in the 10-watt stations.

Let C.E.J. of Boston and H.W.H. of Vandalla, Mo., read this and weep. On December 12, 1925, I pulled in KFJR at Stevensville, Mont., a distance of 1,500 miles, who was using five watts of power. If any proof is needed, I will gladly send a photostatic copy of the affidavit Mr. A. C. Dixon sent me, or they can write to Mr. Dixon, KFJR, now located at Portland, Oregon.—R.A.V., Lafayette, Ind.

### Bill Asks That Copyrighted Music Tell Reserved Rights

WASHINGTON, D. C.—Representative MacGregor of New York has introduced a bill in the house which has been referred to the committee on patents dealing with the Radio copyright situation.

The bill provides that the sale of copyrighted music composition shall carry with it the implied price to the purchaser or other lawful holder, to publicly perform it for profit or otherwise unless there shall be printed on the title page or otherwise conspicuously displayed on it, a notice that the rights of such public performance are reserved to the author or owner. The bill affects composers and publishers and is along the line of certain suggestions made during the course of the recent Radio copyright hearings.

Iowa's attorney general, Benjamin Gibson, has joined forces with the Iowa Radio Listeners League to eliminate interference throughout the state. Mr. Gibson's first move will be the drafting of a statute aimed at manufacturers of Radio receivers which cause interference.

# Increase Your Radio Vision

YOUR Radio set brings to your ears the programs. This arouses a desire to see a likeness of entertainers and stations. Here is where you have need of something to give you this real vision. Our mission is to supply this factor in Radio, and we offer

## RADIO DIGEST, the Eyes of Radio

in each issue of Radio Digest, Illustrated. This, with the printed story, makes your Radio complete, which is a service paramount to all Radio set owners.

### Satisfy Your Curiosity Multiply Your Entertainment

by having each issue of Radio Digest mailed to you as it comes from the press. Then you will avoid the disappointment of missing copies.

### Keep Smiling—Be in the Front Ranks

One entire year of this service NOW ONLY THREE DOLLARS

### Your Best Radio Investment

## FILL IN THE COUPON TODAY

RADIO DIGEST, 510 N. Dearborn Street, Chicago, Ill.

Enclosed find \$3.00 for one year's subscription to Radio Digest. Mail me this service regularly to

Name .....

Address .....

City ..... State .....

**Televocal QUALITY TUBES**

A Technical Triumph Fully Guaranteed

Televocal Corp'n  
614 FIFTH AVE. - NEW YORK

## Radio Comes to Rescue of Postmaster Who Had Chicks Stranded in Office

HOT SPRINGS, Ark.—That Radio serves in many curious ways was illustrated in Hot Springs, Arkansas, once more when the offices of Station KTHS, the New Arlington hotel, brought back the smiles to the lips of Postmaster Carey Johnson, after two days when all the joy had been abstracted from his busy life by the arrival of 100 chicks in his office.

He freely admitted that was too many chicks for his peace of mind, regardless of the fact that they were all beautiful specimens—of the feathered variety.

### Can't Find Missing Keys

Life was going its merry round when a train brought in an over hundred pure bred chicks consigned to one A. B. Keys. Then the clouds began to darken the sunny skies of Postmaster Carey's morning when the carriers could not locate Keys. A search of directories failed to shed any light on the situation, and meantime the chicks got hungry and yet more hungry and their lamentations lifted skyward in outraged cluckings.

One day passed, then another of anxiety for men, postmaster and chicks. Finally a brilliant idea percolated to the postmaster's eranium. "Let's try Radio," Announcer G. C. Arnoux, of KTHS, was consulted. An hour later the call for Mr.

Keys went out over the air, advising him to come get his chicks before the postal clerks took to the woods or made dumpings of same.

### Bite of Hero of Tiger Creek

Far out in the neighborhood of Tiger Creek, beyond reach of mail routes or phone, lived a gent Yclept Swartz, and being a progressive farmer, he owned a Radio. Of course he possessed a mule. His Radio was pointed for KTHS and hearing the pitiful appeal of the post office, he saddled up Betsy and went speeding cross country a good two miles to the bank of the creek where resided the missing Keys.

Three hours later the much sought for owner of the chicks arrived, backed his wagon up to the post office and relieved the harassed postmaster of his unwelcome guests.

Is Postmaster Carey a Radio fan? We should hope to cheep.

## Give Shell Race Data Fast By Short Wave Rebroadcast

SEATTLE, Wash.—When the University of Washington's star oarsmen drubbed the crew of the University of California recently on Lake Washington, Station KFOA "trailed" the races from beginning to end and gave the listeners probably a better picture than the spectators along the shore or in small craft along the cruise could get.

The Seattle Times press boat trailed close behind the racing crews and Palmer K. Leberman, short wave expert, broadcast the descriptions of the races "stroke-by-stroke" through a special 38-meter phone set with which the boat had been equipped. The 38-meter wave was received at the Times office and put on telephone wires which went through two exchanges before reaching KFOA's studio. Here the descriptions were listened to and repeated on 455 meters by the KFOA announcer.

A force of nineteen men was required to do this.

## STATIONS BOAST OF QUICK CHANGE OVER

TWO STATIONS in different vicinities, WJZ at New York and WKRC at Cincinnati, announce that they can now change over from one remote control pick-up point to another, while one announcer is in the middle of a sentence, and have the sentence completed at the second pick-up point by another announcer without listeners being able to detect a second's pause. Evidently both stations have been working along the same line of perfection.

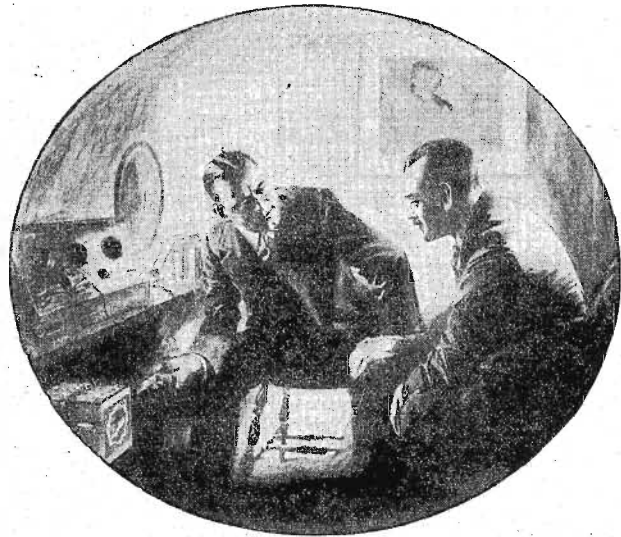

“The little wrinkle that makes my ‘B’ batteries last longer is using the right size Evereadys with a ‘C’ battery”

“I USED to think that because the Eveready ‘B’ Battery No. 772 cost less than either of the larger Heavy Duty Evereadys that I was saving money. As a matter of fact, on four or five tube sets, that was false economy.

“The right size Eveready ‘B’ Batteries to use depends on the number of tubes in your set. The life of the batteries depends on how much you listen in and on whether a ‘C’ battery is employed.”

To get the maximum of “B” battery life and satisfaction, follow these simple rules: On 1 to 3 tubes—Use Eveready No. 772.

On 4 or more tubes—Use the Heavy Duty “B” Batteries, either No. 770, or the even longer-lived Eveready Layerbilt No. 486. On all but single tube sets—Use a “C” battery\*.

Follow these rules, and No.

772, on 1 to 3 tube sets, will last a year or more; Heavy Duties, on sets of 4 or more tubes, eight months or longer.

The average year-round use of a set is two hours a day. If you listen longer, your “B” batteries will have a somewhat shorter life. If you listen less, they will last longer.

Our new booklet, “Choosing and Using the Right Radio Batteries,” is free for the asking. It also tells about the proper battery equipment for the new power tubes.

\*NOTE: A “C” battery greatly increases the life of your “B” batteries and gives a quality of reception unobtainable without it. Radio sets may easily be changed to permit the use of a “C” battery by any competent radio service man.

Manufactured and guaranteed by NATIONAL CARBON CO., INC. New York San Francisco Canadian National Carbon Co., Limited Toronto, Ontario

Tuesday night means Eveready Hour—9 P. M., Eastern Standard Time, through the following stations:

WEAT—New York WGR—Buffalo WGN—Chicago  
WJAB—Providence WOPB—Pittsburgh WOO—Des Moines  
WEEB—Boston WJAB—Pittsburgh WJAB—Minneapolis  
WVBC—Worcester WJAB—Cleveland WOO—St. Paul  
WPT—Philadelphia WJW—Detroit

**Stylish Flaring Model Flat Silk Crepe**

**\$1.00 down!**

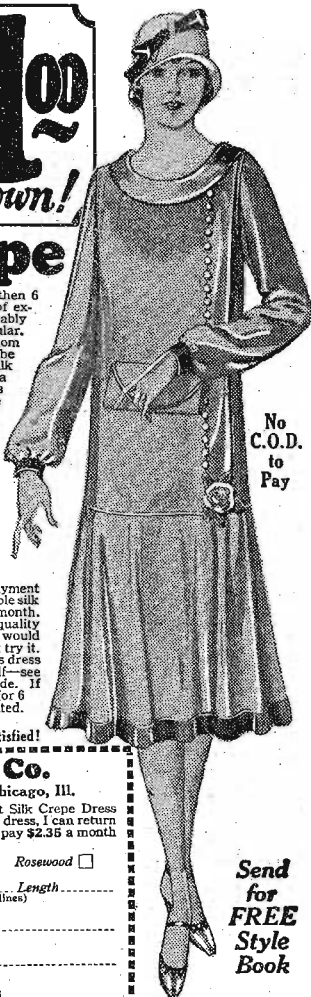

No C.O.D. to Pay

Don't miss this offer; only \$1.00 down and then 6 months to pay for this ultra-stylish model of excellent quality flat silk crepe, fashionably tailored in the new side effect now so popular. Skirt is flaring in front and trimmed at bottom with a band of contrasting color silk. See the stylish rounded collar—the attractive silk rose at the side. Back is plain except for a sash belt of self-material. Try and match this model anywhere else and see how much more you would have to pay. Comes in black, rosewood or palmetto green. Sizes 34 to 44. Total lengths up to 45 inches. No longer. Order by No. S-6. Terms: \$1.00 with coupon, then only \$2.35 a month. Total Bargain Price, only \$14.90.

**6 Months to Pay**

Do you realize how easy our monthly payment plan makes it for you to have this fashionable silk crepe dress? You pay only a little each month. Thousands of well-dressed women buy our quality clothes out of the nickels and dimes they would otherwise throw away. You can too. Just try it. Send only \$1.00 now. (No C. O. D.) Get this dress on approval. Try it on—judge it for yourself—see what an unusual bargain it is. Then decide. If perfectly satisfied send only \$2.35 a month for 6 months. But act quick as our supply is limited. Send coupon and only \$1.00 now.

No Risk to You. Money Back if Not Satisfied!

**Elmer Richards Co.**

Dept. 4415 West 35th Street, Chicago, Ill.

I enclose \$1 deposit. Send me the Flat Silk Crepe Dress No. S-6. If I am not delighted with the dress, I can return it and get my \$1 back. Otherwise, I will pay \$2.35 a month until I have paid \$14.90 in all.

(Check Color) Black  Green  Rosewood

Bust..... Belt..... Hip..... Length.....  
(Be sure to fill out the above lines)

Name.....

Address.....

P. O..... State.....

Send for FREE Style Book



Left—No. 486, for 4, 5 or more tubes. \$5.50.



Right—Eveready Dry Cell Radio “A” Battery 1½ volts

**EVEREADY**  
Radio Batteries  
—they last longer

**A STEP ON THE STAIRS**

(Continued from page 12)

ly as the muffled roar of an automobile engine diminishing rapidly as the car of the state troopers swept out toward the Bay road, evidenced that the long arm of the law was gathering in its own. "There is a streak of light in the East. . . The dawn is coming."

"It has been a hard night for you, dear," remarked John, in a half whisper. "And you were wonderful through it all." "I am afraid I am not a very good detective, John. . . Not nearly so good as Hazel Stanton. . . She has such admirable qualities as a policewoman."

"Forget Hazel Stanton. She was never anything but a minor character in the piece. And as a detective—bah! She was always picking the wrong one."

"She picked you, John. . . I could see it in her eyes. She was a woman first and a detective second, and I hated her. I believe if I hadn't hated her I shouldn't have mixed up in this business at all."

"Then there is that much to her credit anyway. She brought us together. I might still be flitting about in the dark if it hadn't been for your bravery."

"Bravery!" The girl laughed. "I brave? Why I was frightened to death. Every minute of this night I wanted you, Johnny. . . I was so alone. . . So helpless."

"Helpless? Helpless? If you've solved a murder mystery and captured a murderer while helpless, it ought to be a positive pleasure to see you work when you felt sure of yourself."

"Don't laugh at me, John, I mean it. Never in my life again will I be able to forget that horrible front door—firm and strong and tightly barred—but letting terrible creatures walk through it at will, in and out, in the dark."

"You needn't worry about the door any more. Uncle Peleg has had it nailed up. He says he is going away on his long cruise and try to do his permanent dying somewhere else so that his corpse won't have to be carried out through the Turners' last exit. He is giving us this house if you think you can stand to live in its shadows. . . And when we were married, we can cut a new door through the front wall with a glass panel in it, looking out through the cedars toward the bay. . ."

He broke off suddenly and half rose from the davenport. The girl pulled him back with a start of terror.

"Listen, Johnny! What's that?" "It's nothing, dearest. . . It can't be anything now."

"Don't leave me, Johnny. . . It's the step. . . the step on the stairs. . . The hall door is opening."

"It's Harl Singh."

The Hindu grinned. "We have a visitor, Sahib," he said. "A clergyman, who says that Peleg Turner telephoned to him to come at once to marry someone."

"Call Uncle Peleg and show the gentleman in," directed John Carlton.

"What are you delaying for, Harl Singh?" inquired Mary Williams.

CONCLUSION

**KMTR IS "HIGH-BROW"**

(Continued from page 13)

the start. Mammy Simmons, as all in Atlanta, Georgia will remember, was the Uncle Remus story teller at that city for a long, long time, and the memories of Joel Chandler Harris are now being kept alive out on the Pacific coast as well as in the South.

Outside of the concert hour in the evening and Mammy Simmon's home hour for the children, nothing is presented over

KMTR but educational talks and lectures of the highest caliber given by men and women who are authorities in their respective lines. But one remote control studio is used although the station owns and operates the short wave broadcaster 6XBA, designed and built by its chief technician, Freeman Lang, as well as a fleet of public address systems mounted on automobile chassis, which enable the station to reach out and bring in almost any feature that might happen around Los Angeles.

"To those who still think of Hollywood as a movie city, with nothing but Rollis-Basses on the streets and life one succession of gay parties, it would probably be a revelation to listen in on KMTR on a Tuesday evening between 7:45 and 8:30 to hear the broadcast of the Hollywood community sing where the people of Hollywood get together, just as they do in Podunk, Indiana, or any other town in America, and join in community singing.

So KMTR is a high-brow station and proud of it. As the directors say, nearly every Radio station in the country seems to be catering to the low-brow so why not have a few that are avowedly for the high-brow listener.

**"BIG RABBIT"**

(Continued from page 9)

I BREATHED with relief, Miss Tonneson at least was under the protection of Major Gaskill. The prospect of again striking the trail filled me with new life. I hastened to the water front and began making my way along the slips, inquiring about a boat, fearing the party had taken one of the large passenger steamers either for the upper St. Johns or for the East Coast.

At a slip at the front of Laura street I found the trail. A strange gasoline launch, unnamed, had been in the slip for several days and had left early that morning. I had taken aboard six barrels of gasoline consigned to William Duke and remained in the slip until shortly before eight o'clock when a tall white man, two negro men, and two women, both closely veiled, had boarded the launch, arriving in a taxi cab.

The launch had cast off immediately and proceeded up river. Several persons remembered the launch well. One had seen the party board her, and had observed that one of the women appeared to be sick, as she was supported by the white man and the other woman. The latter, according to the men who saw her, either was a stranger, or had been repainted since any former appearance in the port.

The crew consisted of three negroes, none of whom were known. The dock tender had thought the launch was the property of some of the wealthy winter resorters and had not paid much attention to her.

There was no doubt but that we were on the right trail, and that the party had gone up the St. Johns river. But where?

I still was seeking information when the steamer May Garner came down from the points up the river, and as she waded into her slip, I approached to make

inquiries whether she had passed a launch answering the description I had secured. Captain Grove said he had sighted perhaps a half dozen launches during the trip down from Green Cove Springs, several of which he knew.

He had observed one, a large, white cabin launch, which seemed to fit the description. He had noticed it particularly, because it seemed to be hugging the West side of the river, and was far out of the marked channel.

THE May Garner was at that time in the deep cove at Plummer's landing, and the launch, being more than three miles away and on the opposite side of the river, was indistinct. Captain Grove's attention had been attracted to it by its strange course, indicating either that it was in a great hurry and was making chances of grounding by cutting the corners or that it was striving to escape notice.

Satisfied that the launch was the one we were striving to trace and that its passage would be noted at points further up the river I hastened back to the Seminole where, in a short time, Borton rejoined me.

"We were right," he said shortly, seeming to have forgotten our little clash. "The porter is with them. None of the railroad people knows much. The launch was rented in the name of King, by a colored man, and paid for in advance. The party left the car a few minutes after the train reached Jacksonville, Major Gaskill, Miss Tonneson, Trimble and the maid in a taxi. Miss Tonneson either was drugged or sick. They half carried her. The car was switched out into the yards."

"Trimble returned after helping the woman to the taxi and joined the negro porter. Evidently they carried us out of the car and dumped us alongside the railroad in the yards. They were afraid to have us found unconscious in the car for fear the cleaners would call the police. The whole party then went in taxis to a launch at the foot of Laura street. The cab starter, heard directions given."

"I discovered that part of it," I assured him, and, as quickly as possible outlined to him the result of my investigations.

"GOOD—the trail leads up the river," Borton said. "No use starting this late today. They can't hide that trail. We must find out about the regular river boats, and lease the fastest motor

boat we can get. This afternoon we must make the rounds of the lumber dealers and find where Gaskill's mills are located. Possibly they are going to one of his lumber camps. Then we'll get some sleep. We are both half dead and can't push much further without rest."

Anxious as I was to be on the trail I realized his plan was best. The excitement had buoyed us up during the day, but the deadening effect of the drug, the weariness of the ride, the shock of the abuse we had endured, all were telling upon us. I had scarcely realized how sore and weary I was until Borton spoke and then felt ready to collapse. A glance at Borton's face, drawn and gray from fatigue and suffering, proved that pursuit, for the time being, was out of the question.

For two hours more we dragged our pain wracked bodies around the city. In the first lumber office I learned that Gaskill was the ostensible owner of three saw mill plants; one near Federal Point, one near Sanford and a third on Cross Creek. The greater part of the land controlled by Gaskill had been cut over until the output of the mills was small and they were operated spasmodically.

Gaskill had attempted to sell tracts of land for colonization but the deal had fallen through. Borton returned soon after I completed my task. He had engaged a fast motor boat, the Jason, and had learned the time of departure of all up river steamers. We hastily could keep awake during the dinner and, before nine o'clock, we plunged luxuriously into soothing hot water, and afterward fell asleep in a few minutes, I to dream that I was rescuing Roberta Lee Tonneson from the clutches of a huge rabbit which grinned like Borton.

*Dreaming of Roberta in the clutches of a grinning rabbit of giant proportions may have been prophetic for Wen. At any rate the two hounds are set for a devious water trail and the next episode will carry us into a strange and weird setting with the haunting shadows of the Big Rabbit, the girl and her guardians tantalizingly near and yet so far.*

(Copyright 1926 by Hugh Fullerton. All rights reserved.)

The organization of Radio clubs in Oregon continues at a pleasing rate, the latest addition being the McMinnville Radio club which with its initial bow authorized the purchase of apparatus sufficient to "clean the air" in their locality.

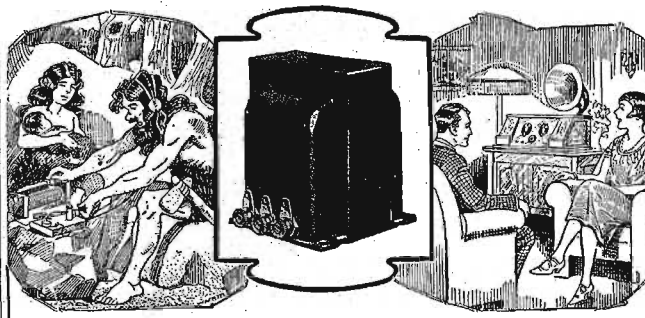

**Bring in Europe on a Victoreen "Super"**

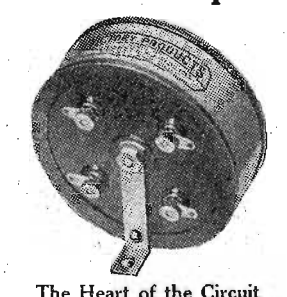

**The Heart of the Circuit**  
 Each 4, No. 170 R.F. Transformers @ 7.00  
 1, No. 150 Coupling Units @ 5.50  
 You can secure these and all other parts necessary from your dealer.  
 Victoreen Air Core Transformers are more than matched—they are actually tuned to guaranteed precision of 1/3 of 1%.

Ask your dealer for a free folder and hook-up of Victoreen "Super" or write directly to us. This folder answers all questions about the Victoreen.

**The George W. Walker Co.**  
 6509 Carnegie Ave., Cleveland, Ohio  
 Branches in principal cities.

**Modernize Your Radio Set!**



From the majestic roll of the grand organ to the high flute like tones of the coloratura, every note—every harmonic—is faithfully reproduced in the Autoformer equipped receiver. No note is too low—and none too high to receive full amplification.

It encompasses the advantages of transformer, resistance, and impedance coupled amplification with the disadvantages of none.

Write for descriptive bulletins.

**THORDARSON ELECTRIC MANUFACTURING CO.**  
 Transformer specialists since 1895  
 WORLD'S OLDEST AND LARGEST EXCLUSIVE TRANSFORMER MAKERS  
 Chicago, U.S.A.

**ARROW BATTERIES**

**Battery Prices SMASHED!**

To Consumers Only

Here is a real battery quality guaranteed to you at prices that will astonish the entire battery-buying public. Order Direct From Factory. Put the Dealer's Profit in your own pocket. You actually save much more than half, and so that you can be convinced of true quality and performance, we give a **Written 2-Year Guarantee**. Here is your protection! No need to take a chance. Our battery is right—and the price is lowest ever made. Convince yourself. Read the prices!

Auto Batteries		Radio Batteries	
6 volt, 11 Plate, \$8.50	6 volt, 10 Amp, \$8.50	6 volt, 11 Plate, \$10.25	6 volt, 10 Amp, \$10.25
12 volt, 7 Plate, \$11.75	6 volt, 150 Amp, \$11.75	6 volt, 11 Plate, \$11.75	6 volt, 10 Amp, \$11.75

**Buy Direct—Send No Money**

We ask no deposit. Simply send us your address and style wanted. Battery will be shipped same day we receive your order! Express C.O.D. subject to your examination on arrival. Our prompt guarantee each battery. We offer 2-year guarantee for cash in full with order. You cannot lose. Send your order today—NOW!

**ARROW BATTERY CO.**  
 Dept. S 1215 So. Wabash Ave., Chicago

# Super-Torodyne: An Improved 8-Tube Super Part IV—Completed Wiring and Operation

By J. E. Owen, Univ. of Okla.

CONTINUING last week's article we shall complete the wiring of the Super-Torodyne as it would be used with an aerial, and will then consider circuit modifications which permit the use of a loop such as the one shown in figure 10.

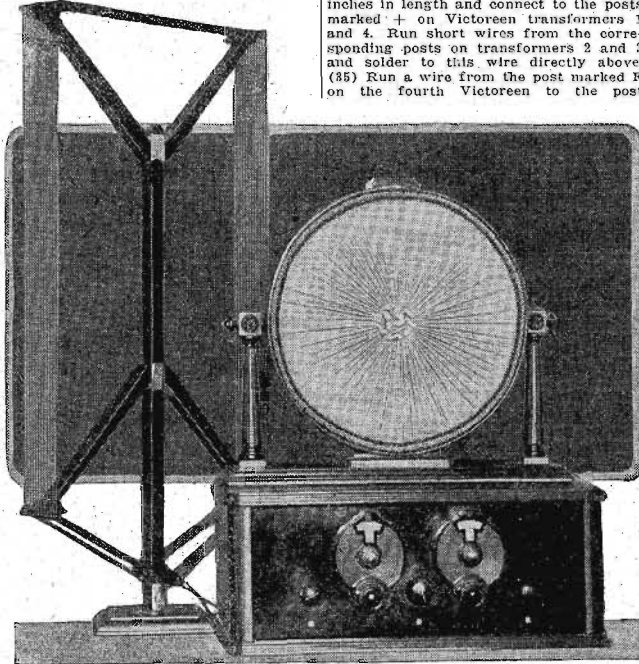

Figure 10

The Victoreen transformers may now be placed upon the sub panel and mounted at an angle of approximately 45 degrees, each to the other, as was explained in the second article.

Operation 27: Run a wire from P on socket No. 1 to P on the first Victoreen transformer. (28) Run a wire from G of socket No. 2 to G on the first Victoreen. (29) Run a wire from P on socket No. 2 to P on the second Victoreen. (30) Run a wire from G on socket No. 3 to G on the second Victoreen. (31) Run a wire from P on socket No. 3 to P on the third Victoreen. (32) Connect a wire from G on socket No. 5 to G on the third Victoreen. (33) Run a wire from P on socket No. 5 to P on the fourth Victoreen. Now run a wire from G on the fourth Victoreen under this transformer and toward the back, where it is connected to one side of the

grid condenser of the second detector. A wire from the other side of this condenser goes to the post marked G on socket No. 6. These wires form the only support for the second grid condenser as may be seen in figures 4 and 7.

Operation 34: Cut a wire about 1 1/2 inches in length and connect to the posts marked + on Victoreen transformers 1 and 4. Run short wires from the corresponding posts on transformers 2 and 3 and solder to this wire directly above. (35) Run a wire from the post marked F on the fourth Victoreen to the post

of the potentiometer and slightly to the right. Run a wire from the moving arm connection of this potentiometer through this hole and to the left terminal of the right Tobe condenser. (39) Drill two holes between Victoreens Nos. 1 and 2. Solder a wire to the lead which connects the posts marked + on the four Victoreens and run it through one of the holes just drilled and over to the right terminal screw on the left Tobe condenser. This wire should be insulated, particularly under the sub panel. A wire should be soldered to it and to the terminal of the Bremer-Tully choke that has no connection.

The binding post strip with its brackets should now be put on the sub panel, and over the Victoreen transformers. Connect a wire from the left binding post marked ANT to the post marked P on the left toroid coil. The second binding post which is also marked ANT is connected to the binding post T on the left toroid coil. Use spaghetti insulation on these leads. Connect the next binding post marked GND to the next one to it marked A BAT. There is a hole between Victoreens Nos. 1 and 2 through which there is no wire. (40) Connect a wire to the binding post marked A BAT-, run it down through this hole, and solder to the negative bus underneath the sub panel.

Operation 41: The next binding post is marked A BAT+. Run a wire from it to the next post which is marked C BAT+. Drill a hole between Victoreens Nos. 2 and 3. (42) Run a wire down through this hole, connecting at the top with the wire common to the binding posts marked B BAT-, C BAT+, and A BAT+. After it passes through the sub panel, bend it straight toward the front until it reaches the front panel, then bend it to the right until it comes directly below the Benjamin battery switch. Use spaghetti on this wire. It is now brought up and soldered

to one terminal on the switch. A short wire connects the other terminal of this switch with the positive bus under the sub panel. (43) From the post marked I on the top Jefferson transformer an insulated wire is run to the binding post marked C BAT-. The next binding post after the B BAT- is the +B detector. An insulated wire is run from this binding post to the binding post on the lower Jef-

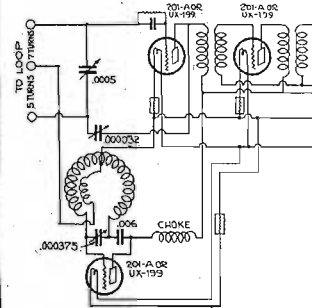

Figure 11

erson transformer marked E. The next binding post on the binding post strip is marked B AMP+. Drill a hole between Victoreens Nos. 3 and 4. (44) Drill another hole between socket No. 7 and the Jefferson transformers. Run a wire from the binding post marked B on the upper Jefferson transformer through this hole, across to the left, then bend to the back and up through the hole between Victoreens Nos. 3 and 4, and connect to the post marked B AMP+. A wire also con-

(Continued on next page)

marked - on socket No. 4, which is really the positive filament post. Take a wire about 8 inches long and connect the posts marked F on transformers 1 and 3. From the post marked F on transformer No. 2 run a lead to the wire directly above it and solder.

Operation 36: Drill a hole back of the hole behind Ampertite No. 4. (37) Run a wire under the sub panel from the left terminal screw of the right Tobe fixed condenser up through and solder it to the wire that connects the binding post marked F on the Victoreens Nos. 1, 2, and 3. (38) Drill through the sub panel, back

## National advertisers can now use profitably

The National Broadcast Authority

# Radio Digest

PROGRAMS Illustrated

Reg. U. S. Patent Off. and Dom. of Canada

## Class Circulation at Mass Price 175,000

Year's Average, Net Paid, Guaranteed or Pro Rata Refund

\$4.28 MAXIMUM MILLINE \$3.64 MINIMUM MILLINE

E. C. RAYNER, Publisher

Radio Digest Publishing Company  
510 North Dearborn Street  
CHICAGO

## Gets Everything But Noise!

Read this convincing letter from a man who has "listened and marveled":

Uden, N. Y. Jan. 16, 1926.

Name Antennae Co.,  
Gentlemen:  
We have found your Kane Antennae the greatest thing we have come across in the way of eliminating interference. It is a real life saver to us, as since we have installed it we get wonderful reception, where before we got only noise.

Very truly yours,  
Ulton Radio Supply Co.,  
By M. Swire."

### Improves Reception 60%

Entirely eliminates all power noises such as trolley transformers, generators, motor buses, Detroit plants, etc. Cuts static and interference bands and signals in two. Proves statements of leading Radio Engineers that fully 75% of so-called "summer stuff" is nothing more than electric power interferences. Dr. Gobetz of Oakland, Cal., says it improves his reception fully 60 percent. Do any more with disagreeable noise.

### \$1.00 Brings BLUE PRINT

Complete Working Drawings and full instructions for erecting this wonderful Antennae. Just send \$1.00 (check will do. Stamps not accepted). A limited number available. Send TODAY.

KANE ANTENNAE CO.  
Dept. 8236, 3024 W. Van Buren St., Chicago.  
Dealers—Send at Once for Attractive Proposition!  
**KANE ANTENNAE**

**FREE** To Each Purchaser of a WORLD 6V or 12V BATTERY

**12-Cell—24-Volt Storage 'B' Battery**

Positively given free with each purchase of a WORLD "A" Storage Battery. You must send this ad with your order. WORLD Batteries are famous for their guaranteed quality and service. Backed by years of successful manufacture and thousands of satisfied users. Equipped with Solid Rubber Cases, an improved anti-acid and leakage. You save 50 per cent and get a

**2-Year Guarantee**

Send in Writing WORLD Batteries "and their friends." That's the best proof of performance. Send your order in today.

**Solid Rubber Case Radio Batteries**  
6-Volt, 100-Ampere . . . \$11.25  
6-Volt, 120-Ampere . . . 13.25  
6-Volt, 140-Ampere . . . 14.00

**Solid Rubber Case Auto Batteries**  
6-Volt, 11-Plate . . . \$11.25  
6-Volt, 13-Plate . . . 13.25  
12-Volt, 7-Plate . . . 16.00

**Send No Money** Just state battery wanted and we will ship day order is received, by Express O. D. No charge to your destination. **FREE** "B" Battery included. **Extra Offer** 5 per cent discount for cash in full with order. Buy now and get a guaranteed battery at 60 per cent saving to you.

**WORLD BATTERY COMPANY**  
1219 So. Wabash Ave., Dept. 48 CHICAGO, ILL.

**World STORAGE BATTERIES**

Get your Radio Digest at 570 centers for the year 1926. Send World Storage Battery Company, 1219 So. Wabash, Chicago, Ill. for announcements.

### NEW SUPER-TORODYNE

(Continued from preceding page)

nects this post to the one next to it marked SPEAKER. The other speaker post connects to the post on socket No. 8 marked P.

#### Test the Wiring

The Super-Torodyne is now wired. Be sure that the Amperite cartridges and the grid leaks are secure in their mountings. Amperites 7 and 8 being the No. 120 type. Insert tubes in their sockets. Connect the A battery to its terminals and notice whether the tubes all turn on and off as the Benjamin battery switch is operated. If everything is satisfactory, disconnect the A BATT+ lead and touch it to the post marked C BATT+. The tubes should now light. Next connect the A BATT+ lead to the post marked B BATT+. The tubes should not light with the switch either in or out. Now connect the lead to the B BATT+ post. The tubes should light with the switch on but should not light when the switch is off. Now connect it to the B+ and the SPEAKER posts in turn. The tubes should not light when connection is made to any of these posts. If the tubes light when they should not, carefully check the wiring until the mistake is found.

#### Operation of the Set

If the set performs as it should, connect the plus A lead to its post, also the C and B batteries as indicated by the binding posts and the wiring diagram. Connect the ground and the antenna leads, also the speaker to their respective posts. The receiver should now be ready for operation. Set the midget condenser at about half the capacity with the potentiometer near the negative side. Rotate

### CLASSIFIED ADVERTISEMENTS

Classified advertisements in Radio Digest produce results. Have you a receiving set to sell? Do you want to buy a Radio? A classified advertisement in this column will sell you your set.

Rates are twenty cents a word for each insertion, ten per cent for six insertions, fifteen per cent for twelve insertions, twenty per cent for twenty-four insertions. Name and address to be included at above rate. Cash should accompany order. Minimum of ten words. Objectionable and misleading advertisements not accepted. Forms close three weeks prior to date of publication, which is first and fifteenth of each month.

#### BLUE PRINTS

Just Out—Actual size template for Radio Digest's latest set—Super-Torodyne, 25c. Instructions appearing in April 10-17-24 and May 1 issues.

Super-Set, Ryan's Simplest Possible 7-Tube Set. Complete instructions, actual size template. How to make a loop. All for 50 cents. Book Dept., Radio Digest, 510 North Dearborn Street, Chicago.

#### MISCELLANEOUS

Photos of Your Favorite Radio Stars. Ten cents and coupon appearing on another page of this issue will entitle you to one of the photos appearing in Radio Digest gallery of stars. Radio Digest, 510 North Dearborn Street, Chicago.

Radio Fans—A year's subscription to Radio Digest is only three dollars. Send your order now. Fill out coupon on page 28.

#### PATENT ATTORNEYS

PATENT ATTORNEYS PATENTS. Booked free. Highest references. Best rates. WATSON E. COLEMAN, Patent Lawyer, 644 G Street, Washington, D. C.

#### POSTAGE STAMPS

One Hundred Stamps, Free; 2c Postage. Toledo Stamp Company, Toledo, Ohio.

#### RADIO

Five tube Radio only \$22.50. Seminole Radio, 427 East 16th St., New York.

600 MILE RADIO—\$2.95. No tubes nor battery needed. Always ready. Fully guaranteed. 200,000 sold. No grinding. A real Radio. Sent postpaid. Order from this advertisement. Crystal Radio Co., Wichita, Kans.

Five tube radio set. \$45.00 New. Order from adv. P. V. Graseberger, Bumpass, Va.

New Federal Orthosonic Type A with or without accessories. Corner Pharmacy, Volga, Iowa.

#### REAL ESTATE

Sell your property quickly for cash, no matter where located, particulars free. Real Estate Salesman, 509 Brownell, Lincoln, Nebraska.

#### SALESMEN WANTED

A PAYING POSITION OPEN to representative of character. Take orders shoe-hoody direct to wearers. Good income. Permanent. Write now. Tanners Shoe Mfg. Co., 3-717 C St., Boston, Mass.

the two main condenser dials until a station is found. Adjust the strength and selectivity of the set with the potentiometer and the midget condenser. A little practice will enable one to tune the set very rapidly and without oscillation in the first detector circuit.

The length of aerial used will depend on local conditions and the degree of selectivity desired. For average reception conditions, one of 60 feet will be sufficient, while a well insulated wire a few feet in length placed under the rug or around the picture moulding will be very good during the static periods of the year. The use of a single wire aerial makes ease of installation, although it is often desirable to use a loop, particularly in localities congested with Radio traffic. With a medium length aerial, the Super-Torodyne will tune out local stations very effectively, even within a very short distance of such stations. This is due, in part, to the use of the toroid coils in the antenna and oscillator circuits.

The directional characteristics of a loop, however, give a higher degree of selectivity. In figure 10, the Super-Torodyne is shown with an Ajax loop, which is well fitted to the circuit. In figure 11 are shown the few modifications which are necessary in order to use this loop. The "center tap" on the loop is one turn off center, while the connections to be

made are shown. No antenna coupler is used. With the Ajax loop, a .000022 mfd. midget condenser should be used for regeneration control.

As a large midget condenser has relatively small body capacity effects on the regeneration control, the tap was taken on the antenna coupler for use with a straight wire aerial in such a way that the midget condenser could be used. In the same way that certain parts were specified for use with this receiver, the accessories required need some attention. For the reproducing element, a good speaker is recommended to take full advantage of the low base range of the Jefferson transformers and the enormous volumes that these stages can deliver. For the tubes, use only standard makes. By properly choosing the Amperite, storage battery instead of dry cell tubes may be used. Have your tubes tested and place the two best in sockets Nos. 1 and 5.

There are no major adjustments to be made in the Super-Torodyne when properly wired. Some minor adjustments have been described from time to time in these articles and when these are made and the set assembled according to the directions, you will find the Super-Torodyne a peer among receivers.

**1<sup>st</sup> down!**  
Balance in easy monthly payments buys a 21 Jewel



**STUDEBAKER**  
The Insured Watch

60 Different Art Beauty Chain FREE!  
Cases & Adjustments. With every watch a 21 Jewel. **FREE BOOK** for Book of Watch. Limit. **Studebaker Watch Co., Dept. X395 South Bend, Indiana**

**It SEPARATES the STATIONS**  
One Dial (1 condenser)  
**GOES THRU STATIC**



**SUPERFLEX—\$80.00 list**  
Dealers—ask us WHY? Test a sample.  
**RADIO PRODUCTS CORPORATION, (Inc.)**  
3816 N. 28th St. Birmingham, Alabama

**ELIMINATE STATIC!**

Enjoy perfect reception regardless of weather conditions. The Static Eliminator—the newest and most startling thing in Radio—cuts out practically all static without loss of volume. And in addition it will help increase selectivity, tune out local stations, sharpen signals, remove noise, lessen interference and prevent re-radiation!

Use it with any receiving set—simply hook up according to our simple instructions and enjoy perfect reception unmarred by static.

Satisfaction absolutely guaranteed—\$1 money back if Eliminator is returned within 3 days. Mail your order today.

**100 Postpaid**

**STATIC ELIMINATOR COMPANY**  
644 United Bank Bldg. Cincinnati, O.

**221 Volt**  
no-acid  
overcharging  
rechargeable

**"B" STORAGE BATTERY**  
\$2.95

Includes Chemical



45 volts, \$5.25; 90 volts, \$10.00; 110 1/2 volts, \$12.50; 135 volts, \$14.75; 157 1/2 volts, \$18.50. Truly the best best buy today. Fully charged on any current including 220-volt system! Any special detector plate voltage had. Tested and approved by leading authorities such as Popular Radio Laboratories. Over 3 years sold on a non-refundable 30-day trial offer with complete refund if not thoroughly satisfied. Further guaranteed 2 years. Knock-down kits at great savings. Complete "Hawley" "B" battery charges \$2.75. Sample cell, 35c. Order direct—send no money—simply pay the expressman cost on delivery. Or write for my free literature, testimonials and guarantee. Same Day shipments. B. Hawley Smith, 317 Washington Ave., Danbury, Conn.

**Greatest Radio Log!**

Showing over 500 Stations and their location with **BOOK OF OUR PRESIDENTS** and 48 States of Union and Map Picture and Biography of Presidents All for 50c Splendid information on all States only \$2.50.

**F. JAENIGKEN CO., 727 S. Dearborn, Chicago**

**BUS BAR WIRE**  
**Use COOK'S**

We make a superior wire of pure copper. Every piece of Cook Bus Bar Wire is now plainly stamped "COOK'S"—your protection against substitutes.

It is finished square or round, properly tinned and correctly tempered for radio use. Furnished in standard lengths of 2 feet.

**EDWARD N. COOK PLATE CO.**  
72 Ship Street Providence, R. I.

REPRESENTATIVES  
A. ALLEN SMITH  
204 E. Fourth St., Los Angeles, Cal.  
WOOD & LANE CO.  
615 Olive Street, St. Louis, Mo.  
MR. W. I. OTIS  
Bialto Building, San Francisco, Cal.  
HARRY J. GARRITY  
31 East 42nd St., New York, N. Y.

**FOR CLEAR, QUIET "B" POWER**



**RADIO Storage "B" Battery**

12 Cells  
24 Volts  
Lasts Indefinitely—Pays for Itself

Economy and performance unheard of before. Recharged at a negligible cost. Delivers uniformly a power that is clear, pure and quiet. Approved and utilized by leading Radio Authorities, including Pop. Radio Laboratories, Pop. Sci. Inst., Standard Radio News, Kelly, Johns, Inc., and other prominent institutions. Equipped with heavy duty plates, heavy regulated diodes. Order yours today!

**SEND NO MONEY** Just state number of batteries wanted and we will ship day after tomorrow. Extra offers 4 batteries in action (28 volts), \$10.50. Pay expressman after examining battery. 4 per cent discount for cash with order.

**WORLD BATTERY COMPANY**  
1219 So. Wabash Ave., Dept. 76 Chicago, Ill.  
Makers of the Famous World Radio "A" Storage Battery  
Patent No. 1,100,000, 1,101,000, 1,102,000, 1,103,000, 1,104,000, 1,105,000.  
All equipped with Solid Rubber Case.

**World STORAGE BATTERIES**  
BATTERY OF WGN-TV-ND-240-KRFB-WGN-60

Get your Radio Dial at 210 West 42nd St. for the new World Storage Battery System. Write, Chicago. Watch for announcements.

**Nightingale**

6-tube Set with Integral Loud Speaker \$75

A wonderful, sharp tuning set of beautiful tone made complete in our own factory. Five tube assembly suffices for most stations, but volume can be tripled by using 6 tube terminal. No wasteful neutralizing condensers but perfect balance of parts. See Nightingale dealer or write to THE GUTHRIE CO., GRAFTON, VERMONT. Makers of the famous Songbird Line.



**Improve the Browning Drake**

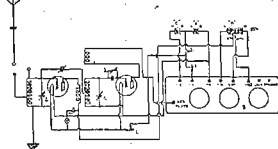

**with a Bradley-Amplifier**

Resistance-Coupled  
**PERFECT AUDIO AMPLIFIER**

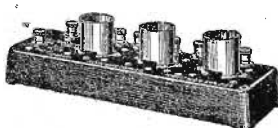

**T**HE Bradley-Amplifier is a ready-built, ready-to-install audio-amplifier. It contains no transformers, but is equipped with Bradley unit resistors which amplify without distortion.

The quality of the Browning-Drake receiver, like any other selective radio set, can be improved by substituting the Bradley-Amplifier for audio-frequency transformers. Try the Bradley-Amplifier with the Browning-Drake receiver and be assured of amplification without distortion.



There are six Bradley unit resistors mounted in the base of the Bradley-Amplifier. These compact units are of solid, molded material, baked under terrific pressure and fitted with silver-plated terminal caps. Bradley units do not deteriorate with age nor are they affected by temperature or moisture. They are permanently soldered into the Bradley-Amplifier, thereby assuring an amplifier which is permanently adjusted for maximum efficiency.

**Bradley-Amplifier** \$15.00



**ALLEN-BRADLEY CO.**  
290 Greenfield Avenue, Milwaukee, Wisconsin

Please send me your literature on the Bradley-Amplifier and other Allen-Bradley products.

Name \_\_\_\_\_

Address \_\_\_\_\_





"Where there is much merit there is great reward."

The merit of the Synchronphase has long been proven.

*Doctor Myer*

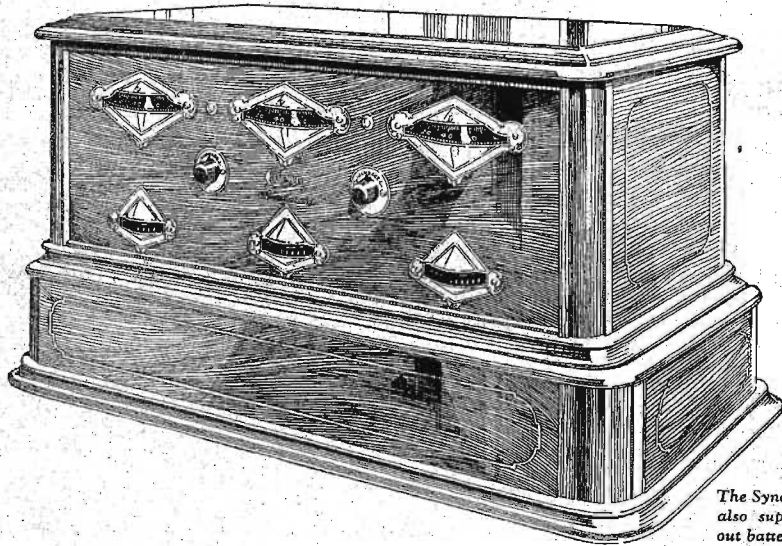

The Synchronphase is also supplied without battery base.

# The Practical Value of Superior Construction

OUT of the thousands of Grebe Synchronphase receivers sold during the past fall and winter, exactly seventy-three were returned to us for replacement or adjustment.

Isn't that about as near to 100 per cent perfection as human frailty can come?

The Synchronphase is built to give full satisfaction to its owner; its record shows that it does.

*Ask your dealer to demonstrate the many exclusive Grebe features that, added to its sound construction, bring complete radio satisfaction*

A. H. Grebe & Company, Inc., 109 West 57th Street, New York

Factory: Richmond Hill, New York

Western Branch: 443 So. San Pedro Street, Los Angeles, Cal.

# THE GREBE SYNCHROPHASE

TRADE MARK REG. U. S. PAT. OFF.

This Company owns and operates stations WAHG and WBOQ; also low-wave rebroadcasting stations, Mobile WGMU and Marine WRMU.



TRADE MARK  
REG. U. S. PAT. OFF.

All Grebe apparatus is covered by patents granted and pending



Grebe "Colortone"

Grebe Binocular Coils  
Reg. U. S. Pat. Off.  
and  
Low-wave Extension Circuits



Flexible Unit Control

Usual Dial

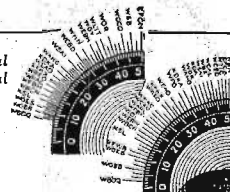

Grebe Dial

Grebe S-L-F Condensers

