

All Wave Length Changes in New Log

Radio Digest

PROGRAMS
Illustrated

OCTOBER, 1927

Copyright 1927 by
Radio Digest Publishing Co.

Title Reg. U. S.
Pat. Off. &
Dom. of Canada

TWENTY-FIVE CENTS

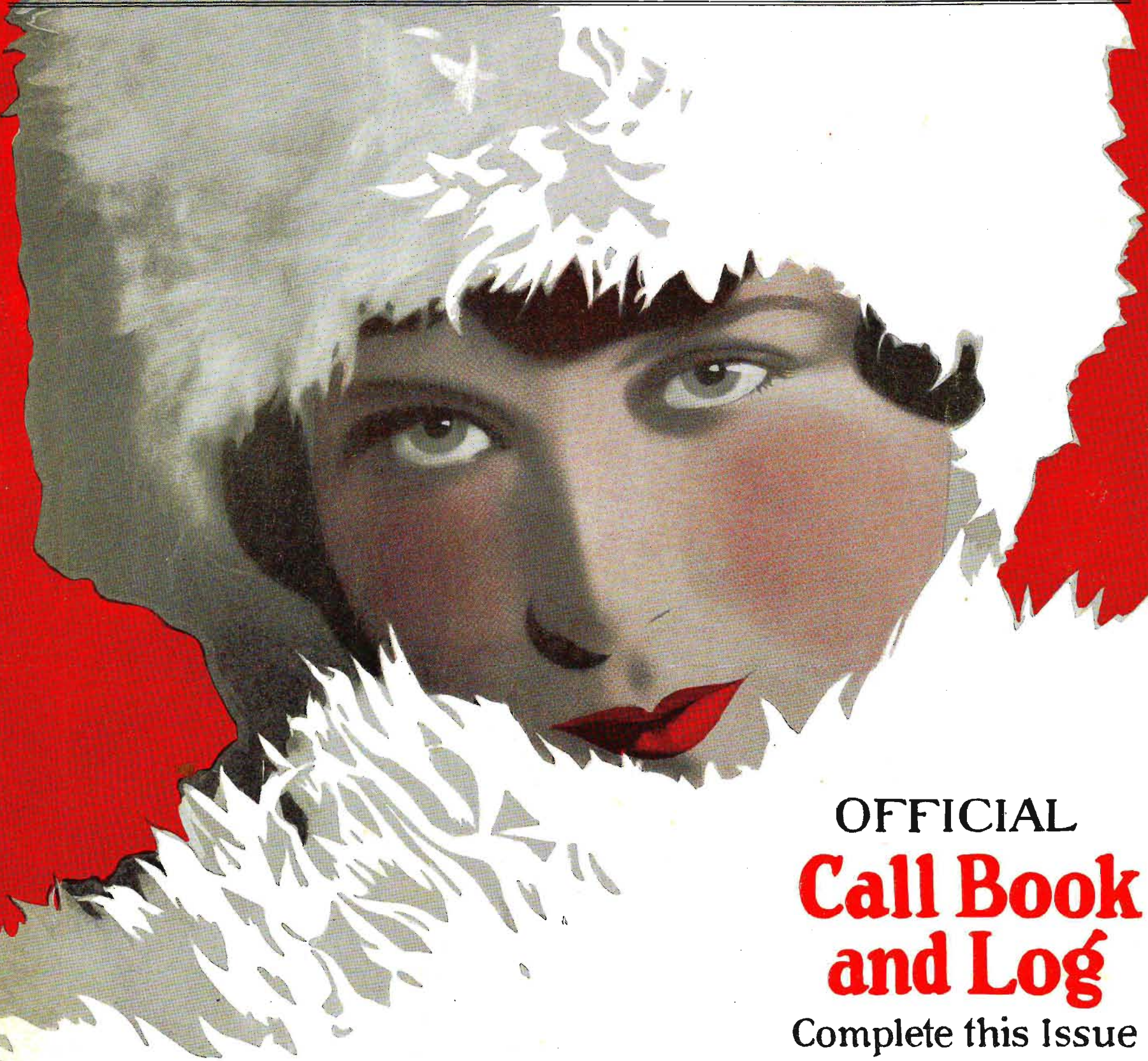

OFFICIAL
**Call Book
and Log**
Complete this Issue

ANNE CORNWALL

*Gold Cup Winner; Football a la Radio; Double Picture Page; That Roxy Hour; WPG Ahoy!
Your Favorite Orchestra; Charms of WFLA; AC Super; Trouble Shooting; WICC Aces*

**30
DAYS
FREE
TRIAL**

7 Tube Set

Single Dial Radio



**Metrodyne
Radio Sets**
Are Equipped
For
**BATTERY or
ELECTRIC**
operation

The
Metrodyne
ONLY ONE DIAL TO TUNE

Retail Price
\$75⁰⁰
Completely Assembled
**Big Discounts to
Agents and Dealers**

Wonderful offer direct from the factory! The world's greatest radio! A perfect working, single dial control, 7 tube receiver! And just to prove our claims, we will ship it to your home for **30 days' free trial**. Test it under all conditions. Test it for distance, volume and tonal quality—and if you are not convinced that it is the **best single dial set** you ever heard, return it to the factory. We don't want your money unless you are completely satisfied.

Three Year Guarantee Metrodyne Super-Seven Radio

**BIG PROFITS
TO AGENTS AND DEALERS**
Our Agents and Dealers make big money selling Metrodyne Sets. You can work all or part time. Demonstrate the superiority of Metrodynes right in your home. Metrodyne Radios have no competition. Lowest wholesale prices. Demonstrating set on 30 days' free trial. Greatest money-making opportunity. Send coupon, a letter or a postal for our agent's proposition.

A single dial control, 7 tube, coast to coast radio set. Tested and approved by Popular Science Institute of Standards, Popular Radio Laboratory, Radio News Laboratory and by America's leading Radio Engineers. Designed and built by radio experts. Only the highest quality low loss parts are used. Magnificent, two-tone walnut cabinet with beautiful, gilt metal trimmings. Very newest 1928 model, embodying all the latest refinements.

Easiest set to operate. Only one small knob tunes in all stations. The dial is electrically lighted so that you can log stations in the dark. The volume control regulates the reception from a faint whisper to thunderous volume, **1,000 to 3,000 miles on loud speaker!** The Metrodyne Super-Seven is a beautiful and efficient receiver, and we are so sure that you will be delighted with it, that we make this liberal **30 Days' Free Trial Offer**. You to be the judge.



**6
Tube Set**
\$48⁵⁰
RETAIL PRICE
Completely
Assembled

30 Days' Free Trial—3 Year Guarantee Metrodyne Super-Six

Another triumph in radio. Here's the new 1928 model Metrodyne 6-tube, two-dial, long distance receiving set. Approved by leading radio engineers of America. Highest grade low loss parts, completely assembled in a beautiful walnut cabinet. Easy to operate. Dials easily logged. Tune in your favorite station on same dial readings every time—no guessing.

Mr Howard, of Chicago, said: "While five Chicago broadcasting stations were on the air I tuned in seventeen out-of-town stations, including New York and San Francisco, on my loud speaker horn, very loud and clear, as though they were all in Chicago."

We are one of the pioneers of radio. The success of Metrodyne sets is due to our liberal 30 days' free trial offer, which gives you the opportunity of trying before buying. Thousands of Metrodynes have been bought on our liberal free trial basis.

**Mail This
Coupon** 
or send a postal or letter. Get our proposition before buying a radio. Deal direct with manufacturer.
SAVE MONEY — WRITE NOW!

MAIL COUPON BELOW

Let us send you proof of Metrodyne quality—our **30 days' free trial offer and 3 year guarantee**

Mrs. Wm. Leffingwell, Westfield, N. J., writes: "The Metrodyne Radio I bought of you is a wow! This is as good as any \$225 machine I have ever seen."

N. M. Greene, Maywood, Ill., writes: "My time is up and the Metrodyne works fine. I got Havana, Cuba, Oakland, Calif., Denver, Colo., Toronto, Canada, all on the loud speaker."

J. W. Woods, Leadville, Colo., writes: "Received the 7-tube Metrodyne in fine condition. Had it up and working same day received. Was soon listening to Los Angeles, San Diego, Oakland and other California points; also St. Louis, Kansas City and other east and south stations—all coming in fine. Am more than pleased. Sure enjoying it."

We will send you hundreds of similar letters from owners who acclaim the Metrodyne as the greatest radio set in the world. A postal, letter or the coupon brings complete information, testimonials, wholesale prices, and our liberal **30 days' free trial offer**.

METRO ELECTRIC COMPANY

2161-71 N. California Ave., Dept. 22
Chicago, Illinois

Gentlemen: Send me full particulars about Metrodyne 6 tube and 7 tube sets and your **30 days' free trial offer**.

Name.....
Address.....

If you are interested in AGENT'S proposition, place an "X" in the square

METRO ELECTRIC COMPANY
2161-71 N. California Ave. Dept. 22, Chicago, Illinois

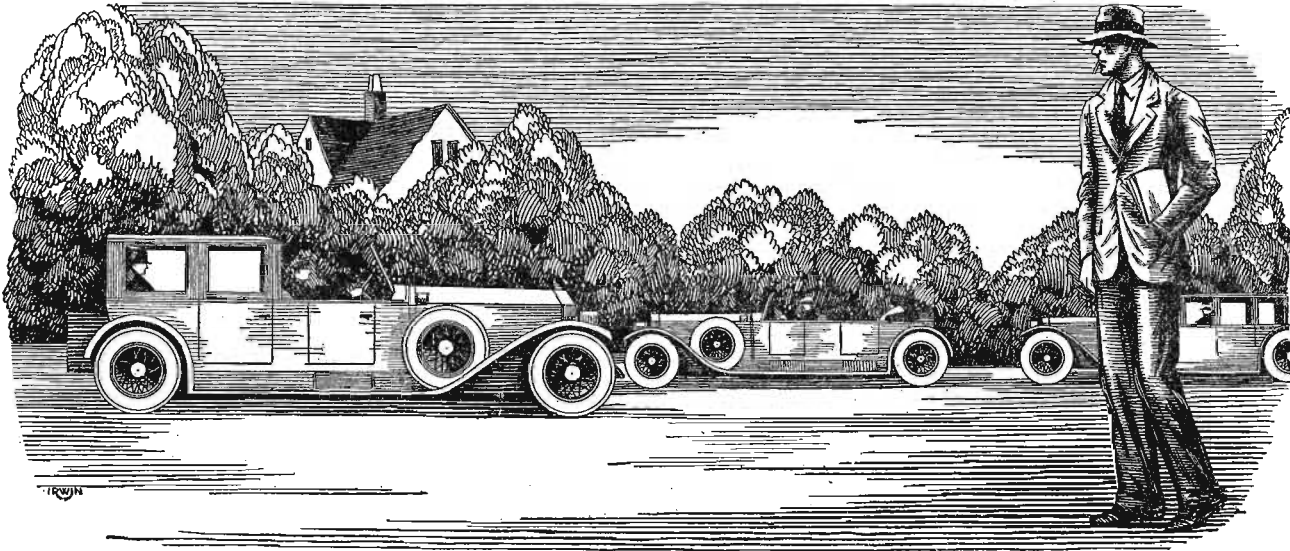

Many times in the old days, while I trudged home after work to save carfare, I used to gaze enviously at the shining cars gliding by me, the prosperous men and women within. Little did I think that inside of a year, I, too, should have my own car, a decent bank account, the good things of life that make it worth living.

I Thought Success Was For Others

Believe It or Not, Just Twelve Months Ago I Was Next Thing to "Down-and-Out"

TODAY I'm sole owner of the fastest growing Radio store in town. And I'm on good terms with my banker, too—not like the old days only a year ago, when often I didn't have one dollar to knock against another in my pocket. My wife and I live in the snuggest little home you ever saw, right in one of the best neighborhoods. And to think that a year ago I used to dodge the landlady when she came to collect the rent for the little bedroom I called "home"!

It all seems like a dream now, as I look back over the past twelve short months, and think how discouraged I was then, at the "end of a blind alley." I thought I never had had a good chance in my life, and I thought I never would have one. But it was waking up that I needed, and here's the story of how I got it.

I WAS a clerk, working at the usual miserable salary such jobs pay. Somehow I'd never found any way to get into a line where I could make good money.

Other fellows seemed to find opportunities. But—much as I wanted the good things that go with success and a decent income—all the really well-paid vacancies I ever heard of seemed to be out of my line—to call for some kind of knowledge I didn't have.

And I wanted to get married. A fine situation, wasn't it? Mary would have agreed to try it—but it wouldn't have been fair to her.

Mary had told me, "You can't get ahead where you are. Why don't you get into another line of work, somewhere that you can advance?"

"That's fine, Mary," I replied, "but *what* line? I've always got my eyes open for a better job, but I never seem to hear of a really good job that I can handle." Mary didn't seem to be satisfied with the answer, but I didn't know what else to tell her.

It was on the way home that night that I stopped off in the neighborhood drug store, where I overheard a scrap of conversation about myself. A few burning words that were the cause of the turning point in my life!

With a hot flush of shame I turned and left the store, and walked rapidly home. So that was what my neighbors—the people who knew me best—really thought of me!

"Bargain counter sheik—look how that suit fits," one fellow had said in a low voice. "Bet he hasn't got a dollar in those pockets." "Oh, it's just 'Useless' Anderson," said another. "He's got a wish-bone where his back-bone ought to be."

As I thought over the words in deep humiliation, a sudden thought made me catch my breath. Why had Mary been so dissatisfied with my answer that "I hadn't had a chance?" *Did Mary secretly think that too?* And after all, wasn't it *true* that I had a "wish-bone" where my back-bone ought to be? Wasn't that why I never had a "chance" to get ahead? It was true, only too true—and it had taken this cruel blow to my self-esteem to make me see it.

With a new determination I thumbed the pages of a magazine on the table, searching for an advertisement that I'd seen many times but passed up without thinking, an advertisement telling of big opportunities for trained men to succeed in the great new Radio field. With the advertisement was a coupon offering a big free book full of information. I sent the coupon in, and in a few days received a handsome 64-page book, printed in two colors, telling all about the opportunities in the Radio field and how a man can prepare quickly and easily at home to take advantage of these opportunities. I read the book carefully, and when I finished it I made my decision.

WHAT'S happened in the twelve months since that day, as I've already told you, seems almost like a dream to me now. For ten of those twelve months, *I've had a Radio business of my own!* At first, of course, I started it as a little proposition on the side, under the guidance of the National Radio Institute, the outfit that gave me my Radio training. It wasn't long before I was getting so much to do in the Radio line that I quit my measly little clerical job, and devoted my full time to my Radio business.

Since that time I've gone right on up, always under the watchful guidance of my friends at the National Radio Institute. They would have given me just as much help, too, if I had wanted to follow some other line of Radio besides building my own retail business—such as broadcasting, manufacturing, experimenting, sea operating, or any one of the score of lines they pre-

pare you for. And to think that until that day I sent for their eye-opening book, I'd been waiting "I never had a chance!"

NOW I'm making real money. I drive a good-looking car of my own. Mary and I don't own the house in full yet, but I've made a substantial down payment, and I'm not straining myself any to meet the installments.

Here's a real tip. You may not be as bad off as I was. But, think it over—are you satisfied? Are you making enough money, at work that you like? Would you sign a contract to stay where you are now for the next ten years, making the same money? If not, you'd better be *doing* something about it instead of drifting.

This new Radio game is a live-wire field of golden rewards. The work, in any of the 20 different lines of Radio, is fascinating, absorbing, well paid. The National Radio Institute—oldest and largest Radio home-study school in the world—will train you inexpensively in your own home to know Radio from A to Z and to increase your earnings in the Radio field.

Take another tip—No matter what your plans are, no matter how much or how little you know about Radio—clip the coupon below and look their free book over. It is filled with interesting facts, figures, and photos, and the information it will give you is worth a few minutes of anybody's time. You will place yourself under no obligation—the book is free, and is gladly sent to anyone who wants to know about Radio. Just address J. E. Smith, President, National Radio Institute, Dept. M-96, Washington, D. C.

J. E. SMITH, President,
 National Radio Institute,
 Dept. M-96, Washington, D. C.
 Dear Mr. Smith:
 Please send me your 64-page free book, printed in two colors, giving all information about the opportunities in Radio and how I can learn quickly and easily at home to take advantage of them. I understand this request places me under no obligation, and that no salesmen will call on me.
 Name
 Address
 Town State

THE millions who have listened to former Farrand Speakers will be astounded to learn that there is now an even better radio speaker—the Farrand Oval—which sets an entirely new standard of quality and value.

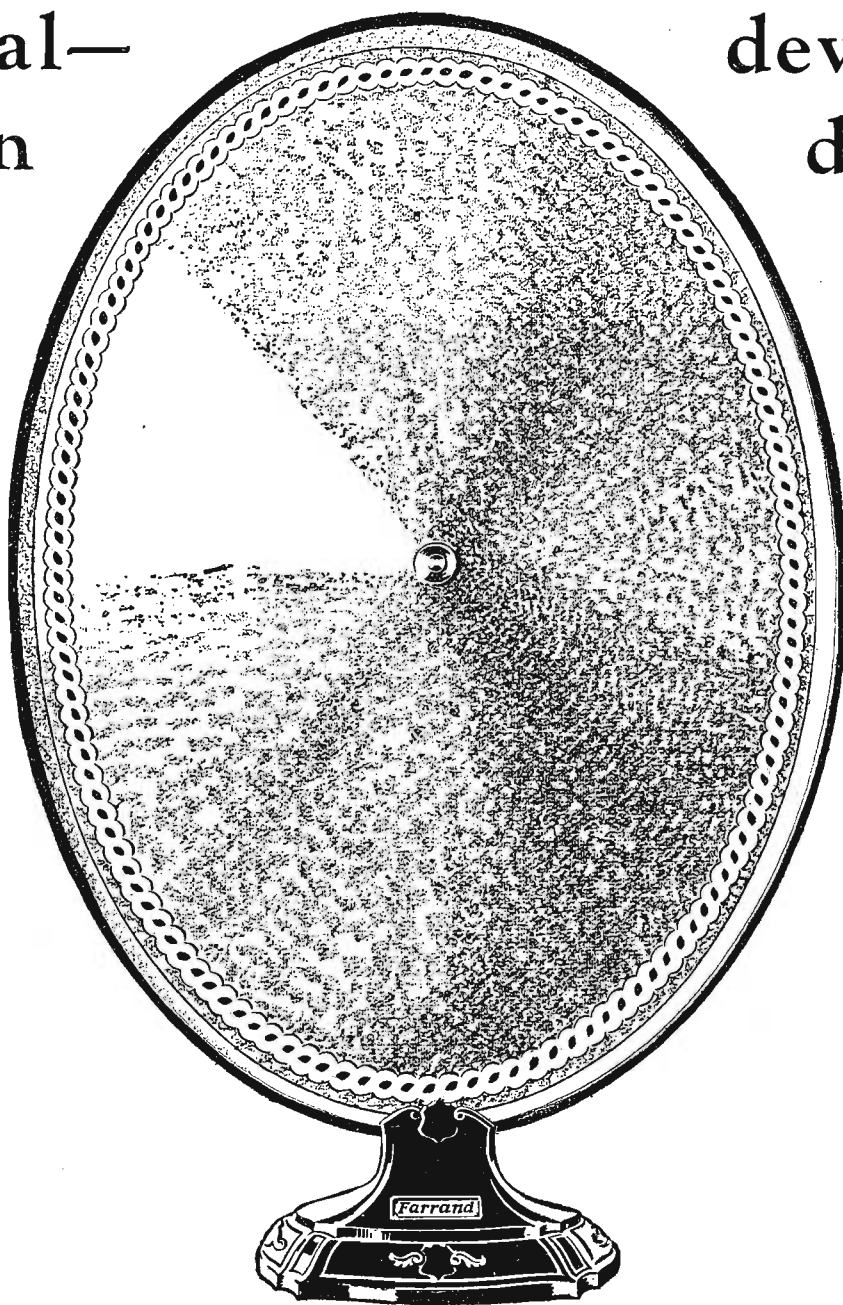

Again radio reception reaches new heights—and again Farrand is responsible. For here is both tonal purity and volume acceptance developed to a degree hitherto unknown. At better radio stores everywhere.

Farrand NEW OVAL

FOUR MODELS—The *Oval* SENIOR (Model 24), at \$32.50—The *Oval* JUNIOR (Model 20), at \$16.50—The *Oval* WALL (Model 30), at \$45—The *Oval* PEDESTAL (Model 30-P), at \$60.00. Slightly higher in Far West and Canada.

FARRAND MANUFACTURING CO., INC., LONG ISLAND CITY, N. Y.

Major White—Dean of Sports Announcers



WHEN the last story has been told of all the great fights that have been broadcast from the arena the name of J. Andrew White will stand as the dean and peer of them all. He was the first ever to carry a microphone to a ring-side when he broadcast the Dempsey-Carpentier fight six years ago. He has been trailing around with the microphone at all the big fights ever since. As vice president and general manager of the Columbia Broadcasting System he is now engaged in presenting grand opera stars and famous artistic productions to Radio audiences.

Major White, in fact, has long been celebrated as a dilettante and in every sport finds a species of art, which he quickly wins and flashes with nimble wit to the waiting listener. Four years he has served as master of ceremonies at the Radio Industries banquet in the Hotel Astor, New York—the premier social event of the year in Radio. His polish and poise make him a favorite after dinner speaker. The first of a series of articles dealing with the science of broadcasting fights and other sports by Major White begins on page fifteen.

WJR MYSTERY BOX PROVIDES GIRL \$500

I. MILDRED ASH IDENTIFIES WHOZIT CABINET

Many Prize Winners Happy Over Awards—Famous Radio Game Soon to End

PRIZE WINNERS

- Station CKY, Winnipeg, Canada
First Prize, \$500.00—Mrs. T. W. O'Brien, 354 Woodlawn Ave., Deer Lodge, Winnipeg, Man., Canada.
- Second Prize, \$300.00 Federal Orthosonic Receiver—R. E. Parker, Lovelady, Texas.
- Third Prize, \$200.00 Howard Receiver—George E. Bender, 1824 Park Ave., Harrisburg, Pa.
- Station WJR, Detroit, Michigan
First Prize, \$500.00—I. Mildred Ash, 711 W. 8th St., Sioux Falls, South Dakota.
- Second Prize, Zenith Radio Set—Mrs. E. Taylor Campbell, St. Francois, Missouri.
- Third Prize, Zenith Radio Set—Harry J. Achenbach, Bloomsburg, Pa.
- Station KOA, Denver, Colorado
First Prize, \$500.00—John Thomas Levi, 11 S. Sherman St., Denver, Colorado.
- Second Prize, Zenith Radio Set—Robert H. Curtis, 2305 Euclid Ave., Boulder, Colorado.
- Third Prize, Zenith Radio Set—Mrs. I. D. Sevens, 1101 W. 41st St., Oklahoma City, Oklahoma.

Dr. Whozit's Mysterious Cabinet is no longer a mystery. The identity of its builder has been solved. No sooner was the September issue of Radio Digest on the way to its readers with a picture of the nameless Whozit entry for WJR, Detroit, than a telegram came flashing into the office from Miss I. Mildred Ash, 711 W. Eighth St., Sioux Falls, S. D. It read as follows:

"My Radio Digest just received and was happily surprised to see the picture of my W. J. R. Whozit offering. Am sorry my Whozit cabinet seems to be an orphan, and will write you full tomorrow and clear up the ownership of the WJR Mystery Entry."

Later came a letter from Miss Ash, in which she expressed her happiness and surprise. She said:

"Imagine my surprise yesterday afternoon to take down the receiver of the telephone on my desk and hear my sister's voice say, 'You've won that Whozit prize. Your cabinet is shown in Radio Digest.'"

Pocketbook Suffered

"I went to your city in July for my vacation and had planned to call at your office and see the Whozit entries, and regret very much now that I did not do so. But unfortunately someone performed a serious operation on my pocketbook en route and I arrived in Chicago minus all but five dollars of the sum I started out with. That rather dampened my enthusiasm and shortened my stay."

"One is seldom satisfied with the results of their efforts, yet you are right in saying that the Whozit cabinet which I sent in represented, not only a great deal of work, but considerable outlay. The cabinet was modeled somewhat in imitation of the Federal Radio cabinet—possibly because I have a perfectly good Stewart Warner set of my own! I was unable at that time to get the services of a cabinet maker, so it was built by a carpenter. The material used was heavy, and the curve top, you will find, is made of beaver board."

And thus, detail by detail, Miss Ash proved conclusively that she knew all about the mysterious cabinet—and even held the expressman's receipt of delivery. The cabinet was arranged in a way that, by turning a regular Radio dial, the various artists and the five facts were shown on tracing cloth through an opening in the panel. The work was exceptionally well done and the judges promptly agreed that Miss Ash was entitled to the \$500 awarded for Whozit Station WJR, Detroit. The other prize winners are published in the above list.

Burn Ice, Hear Atoms at Chicago Radio Show

A "THEATER of Wireless Wonders" will be one of the most amazing attractions at the Chicago Radio Show, somewhat expanded and amplified from the one shown in the East at the Radio World's Fair.

The exhibits, which will be grouped on the balcony of the main exposition hall, will include devices by which the infinitesimal atoms can be measured, seen and even heard. Amplifiers which build up sound to millions of times its original volume will make flowers "talk" and other devices will touch them with a wireless ray which will instantly freeze them into brittleness.

Cold heat will be transmitted through the air and a cake of ice burned up before the eyes of the spectators. Another machine using 350,000 volts of electricity will send a ray at the speed of 150,000 miles

LADY OF THE FURS ADORNS OUR COVER

THESE equinoxial storms, you know, might blow up a big blizzard almost any time and it's best to be prepared. Besides, there'll be lots of cold days to sit in the grandstand and watch the football games. These may be some of the reasons why sweet Anne Cornwall is all furred up on the Radio Digest cover this issue. She must take good care of her throat because she sings for the Radio listeners over WMAQ, WEBB and WQJ from the Tivoli, the Uptown, the Chicago and other well known theaters.

an hour. Scientists will show how they measure one-ten-millionth of an inch.

The Coliseum, the north hall and the annex will be used by the Radio show this year. The booths will be of a pergola type in two tones of lavender and with the tops covered with green smilax and lavender wistaria. More than a ton of smilax has been purchased for this use.

J. Elliott Jenkins, famous Radio engineer, is installing a model broadcasting station in the ballroom of the annex from where nearly a score of Chicago stations will give special programs.

The Chicago show will be held during the week of October 12 to 16, inclusive. By opening both ends of the Coliseum Annex facilities have been provided for taking care of a record-breaking crowd.

Karlograph Photos in 20 Seconds

BERLIN.—Karlograph wireless transmission of photographs will probably be an established service this summer between Berlin and Vienna. Already 100 pictures have been sent by this system to Rio de Janeiro, Rome and other cities with noteworthy clearness.

Crown School Teacher "Radio Queen" at Fair

Edith Amelia Smith, Maryland, Tells Radio Benefits

EDITH AMELIA SMITH, crowned Radio Queen of America, at the Radio World's Fair, New York City, is a high school teacher at Hamilton, Md. She succeeds Mrs. Lotta Harrauff of Princeton, Ill., who was awarded the crown last year.

Miss Smith's winning essay was entirely in her own handwriting and consisted of about 3,500 words. It was profusely illustrated with pictures of women who have figured prominently in Radio news.

"Radios are blessings to women teachers," she reports. "At home they can hear many lectures which they can use to brighten the lesson in the class room. Current events are heard; synopses of operas given; foreign language lessons are conducted, all of these illuminate the teachers' prosaic speeches at school. Again, if there are Radios in school, geography and history lessons become enriched by spot news, the quick reports of the world's happenings. Music lessons are better interpreted; athletics become more interesting; domestic science lessons are no longer a tiresome household routine but a joy to the student; the foreign language hour is enlivened. Oh, if all the schools could be equipped with Radios! How quickly papers could be marked, how interesting everything connected with school work would become!"

Miss Smith did not use a superfluous word in extolling Radio, simply citing example after example of benefits accruing to women interested in broadcasting.

Thousands of essay compositions were written by girls and women of all ages, who showed keen interest in Radio and the great fair held annually in Madison Square Gardens, New York.

SHORT WAVES

By Marcella

WGN's Tyson in Dangerous Thirties; Chester Gaylord Hard-Hearted Lothario; Eddy Borroff Goes Fishing in Matrimonial Seas; Few Facts About Youngest Baritone; Milwaukee Claims Nate; Golden-Voiced Cecil Disappoints Imogene.

THRILLED! Well, wouldn't you be if two of the handsomest men in Radio sent you love and kisses at the end of a vacation letter written to the Radio Digest? Oh, how I hope those Mona Motor Twins, John and Ned, come through here after their vacation and I really get to meet them. They saw the Ray-O-Vac twins on their way up north and discovered that Russ Wildey has a new little baby girl. Isn't that darling?

Isn't it terrible how people will tell you things that aren't true and then you repeat them and get into all sorts of trouble? That's what happened to Marcella. Somebody, I wish I could remember who, told me that Rocky Wolf of WLS was not married and it seems that he has been not only once but twice and he has a little son two and a half. I might have known he was too good looking to be single.

Last week, Mrs. J. W., you probably read that Ann Williams was a blond. You know, I thought she was. She isn't at all, she is a brunette with soft brown eyes. And she is 5 ft. 6 in. tall and slim. Her last name is Heinze. Her husband is very tall and has the blackest hair. Isn't it funny how you can get your best friends mixed up? You also asked about John Reed Tyson of WGN. Here's what Frank Dahm says about him: "John Reed Tyson is about thirty-five—yes, in those dangerous thirties—rather short in stature, with black curly hair and blue eyes. He's WGN's popular morning announcer and he is beloved by the blind and shut-ins whose special programs he presents. Take warning, gals—he's married!"



The bedtime story teller you admire so at WCX, Helen, is Mr. Tomy, the announcer. Here is what he says about himself. "I, Neal Tomy, am the story teller at Skeezix time. Forty-eight years old. Found a girl at Northwestern university who suited me in 1899, so I married her in 1904, and she still suits me in 1927. My only worry is that I may cease to suit her. We have two kids, the boy 21 and the girl 15. My hair, what there is left of it, is gray. I weigh very little to speak of and from what the kiddies say it must be a lot easier to listen to me than to look at me."

Dorothy, there is not the slightest use in being in love with Chester W. Gaylord, (the Lothario of WTAG). He is one of those hardened bachelors wrapped up in music and his broadcasting. Here he has been on the air at least two years and is still single. He was a war hero, and it was while he was in service that he learned to play the saxophone. He used to play with Paul Whiteman's orchestra. The piano is, however, his real instrument.



Tarpon fishing was what Eddy Borroff gave the KYW staff to understand sent him down to St. Petersburg so often. They all thought he was a little funny but did not consider it seriously until Eddy began running down to Columbus, Ohio, and they knew there were no tarpon down there. But Eddy was after the same little fish, that pretty little lass, Marion Law, who used to sing at KYW several years ago. And by the time you read this Eddy will be at the microphone and I shouldn't be surprised if Mrs. Borroff will be there with him.

Fred Feske and Kay Ronayne are both, well, you know, Peg, but not to each other. For some unknown reason each refuses to talk about it or let any public announcements be made. But then, did you ever know two more dangerous vamps on the air? Awfully glad to get your chatty letter and enjoyed your remarks about Jack Little. By the way, he is married too.

I can't see any reason, N. Dean Cole, why you should think Marcella is someone else than who she is. A blond is certainly not a brunette. How would you like it, if I said you were Mr. Searle just because you came into our office with him and I might easily do that, not having seen you. However, Jesse, Mr. Cole says the wonderful harpist you admired so much at WHO is a young lady named Garnette Arrick, and he promises her complete history and a picture. Look for it next issue.

(Continued on page 14)

CONTENTS

Radio Digest, Illustrated, Volume XXII, Number 3, published Chicago, Illinois, October 1, 1927. Published monthly on the first of each month by Radio Digest Publishing Co. (Incorporated), 510 N. Dearborn Street, Chicago, Illinois. Subscription rates yearly, Three Dollars; Foreign Postage, One Dollar additional; single copies, Twenty-Five Cents. Entered as second-class matter Sept. 6, 1927, at the post office at Chicago, Illinois, under the Act of March 3, 1879. Title Reg. U. S. Patent Office and Dominion of Canada. Copyright 1927, by Radio Digest Publishing Co. All right reserved.

"All the News in Radio".....	4 to 15
Marcella.....	4
Girl Wins \$500.....	4
"Theater of Wireless Wonders".....	4
Crown Radio Queen.....	4
Pat Barnes Wins Announcer's Cup.....	4
Commission Swings Axe.....	5
Broadcast Activities in Pictures.....	6
Radio Personalities and Events—Pictures.....	7
Norman Brokenshire Strolls WPG Boardwalk.....	8
"Miss America".....	8
Marie Kieney, WOW Pianist.....	8
Big Audiences for Radio Football.....	9
International Radio Conference.....	10
Rival Cities Unite on WFLA.....	10
Fitz Sisters Thrill at WBAL.....	11
Close-Up of Roxy and Gang.....	11
Navy Captures Friends on NAA.....	11
War Ace Teaches Flying at KOA.....	13
Homemakers Page.....	14
Reminiscences of Famous Sport Events, Major J. Andrew White.....	15
Finding and Fixing Trouble.....	17
Transform Old Set to Socket.....	19
How to Build an A. C. Super, by John G. Ryan.....	21
Editorial.....	24
Advance Programs and Highlights of the Air.....	26 to 36
Official Log and Call Book.....	39
Evening at Home Table.....	46

Looking Ahead

Further Reminiscences of the famous sports announcer, J. Andrew White, will be found in the November issue of Radio Digest. Major White has had a rich experience as a trained observer at close quarters with some of the world's greatest sporting events.

What is the worth of the Radio beacon? Will this latest device of aerial communication solve the safety problem for flying craft? These questions will be discussed and illustrations shown of the Radio beacon at work in the next Radio Digest.

Making It Work—Another up-to-the-minute discussion of modern improvements in set building by a member of the Radio Digest technical staff. There's a hint of a new set in the offing.

Artists and their studios will be seen and talked about in our next issue of Radio Digest. Perhaps your favorite will be among them. Every issue finds a wealth of interesting information about the personalities who entertain you on the air.

Special articles about broadcasting stations and artists, with photographs, are desired. No manuscripts accepted unless typewritten and prepaid, or returned without return postage being included. All manuscripts are sent at owner's risk.

Newsstands Don't Always Have One Left

WHEN YOU WANT

Radio Digest

YOU WANT IT!

BE SURE OF YOUR REGULAR COPY BY SUBSCRIBING NOW

SEND IN THE BLANK TODAY

Publisher Radio Digest, 510 N. Dearborn St., Chicago, Illinois.

Please find enclosed check M. O. for Three Dollars (Four, Foreign) for One Year's Subscription to Radio Digest, Illustrated.

Name

Address

City State.....

PATRICK H. BARNES WINS GOLD CUP

SILVER AWARD VOTED TO JOE FAASSEN, KSO

Radio Digest's National Poll Finds Most Popular Mike Men in Mid-West

Iowa Divides Her Ballots

4th Annual Announcers' Contest Reveals Hosts of Admirers in Distant States

PATRICK H. BARNES, WHT, Chicago, is the world's most popular announcer for 1927.



"To rain, or not to rain, that is the question," quoth P. Hamlet Barnes in one of his various roles as a weather prophet over WHT. Count on cyclones or tornadoes when the Melancholy Dane prognosticates.

Uncle Joe Faassen, KSO, Clarinda, Ia., takes second place in an exceptionally close race for the Radio Digest Fourth Annual gold cup.

Henry Field, KFNE, Shenandoah, made a fast sprint in the final mail receipts and dashed across the tape, third in line.

The contest has been under way much longer than the usual period, owing to the change over of Radio Digest from a tabloid Radio newspaper to a full fledged monthly Radio magazine. As announced, under the original conditions, ballots were received until midnight of September 22nd. The last ballot came from Muscatine, Ia., and was in favor of Henry Field.

Two Cups for Pat

Pat Barnes, who took the pace and held it from the beginning, is the first announcer to win two cups. He captured second place and the silver cup in 1926, as many readers will remember. His most intimate friends blamed his failure to win the gold trophy to a late start in the campaign. He was passed at the finish by Earl May of KMA, Shenandoah. Both cups were presented at the 1926 Chicago Radio show.

This year, Al Carney and other intimates of the WHT favorite, began the campaign with the first issue of ballots and carried through to the end. There was no faltering in the effort to see that Pat received the votes, although the campaign was less spectacular than last year.

Iowa Vote Divided

The Iowa vote was divided among three strong candidates. Dean Cole at WHO, Des Moines, got away to the best start, but failed to hold on at the last. Uncle Joe did not start so well, but made consistent gains, especially at the last. Henry

Field's ballots were spasmodic. There were days when the envelopes opened by the mail department of Radio Digest seemed to indicate that Henry was going to make a landslide, as his fellow townsman did last year. Then there would be nothing. It was thought that those who had been saving for the bonus would make up for the dull periods. This prospect did not come up to the fullest expectations. However, Iowa gets the silver cup for genial Uncle Joe of the Berry Seed station.

"Am enclosing my ballots for Milton J. Cross of WJZ," wrote Mrs. A. J. Byrne of Florence, S. C., "and I am hoping that the East can produce a gold cup winner."

Mr. Cross seems to have many friends, but not quite enough to meet the determined efforts of the middle westerners this year. It may be well to remember that the East took the first gold cup awarded, which was presented to Graham McNamee of WEAf at the New York show four years ago.

FOUR MIKE MEN NOW HOLD PRIZE AWARDS

- 1924—George Dewey Hay
- 1925—Graham McNamee
- 1926—Earl E. May
- 1927—Patrick H. Barnes

PROBABLY no trophy in the world of Radio has been more widely coveted than the annual Radio Digest Gold Cup. The first one was awarded to George Dewey Hay, the "Solemn Old Judge" who at that time was announcer at WLS. Each year has found the rivalry keener. The cups are always designed to resemble the regulation microphone, and are publicly presented either at the New York or Chicago Radio show.

BARNES IS VERSATILE FORECASTER



While here the versatile Pat sits along side himself as female operatic queen, Mme. Gargola, who predicts, "It shall be fair, it shall be fair, fair, fair and warmer in the southern part of Illinois-ois." At right Mr. Barnes appears as none other than the infallible prophet, Lord Helpus—"Bally, bloomin' rain soaks you to the bloody skin dawntchaknow!"

Strong for Cross

Speaking of Mr. Cross, another interesting letter in his behalf comes from Mrs. Lizzie Moody, 325 N. Hopkins ave., Sayre, Pa. She says:

"Enclosed find complete set of coupons for Milton J. Cross. We comprise a family of three, but sometimes are double this number and we all would vote for Mr. Cross if we had a chance. We all get up early Sunday mornings for his enjoyable children's hour and are always glad when he is at his post, whether in studio or elsewhere. I cannot enjoy church services or entertainments, for I am deaf, but I hear perfectly over the Radio with head phones. Congratulations for the new Radio Digest. It is fine."

Radio Digest's gold cup award is primarily the business of the readers and for that reason some of the letters that are typical of the many are published.

Just to show that all of Pat Barnes' friends are not limited to Illinois and Wisconsin, here is one from Iowa, where he had his strongest competition.

Iowa Votes for Pat

"Please find my series of ballots for the gold cup announcer all marked for Pat Barnes of WHT. Here's hoping good old Pat wins. Now, don't forget to credit the bonus, because I think Pat will need every one he can get. I am glad to find your last Radio Digest very much improved. I

enjoy it very much and will always be a reader.—Clarence Harper, Bayfield, Ia."

This isn't typical, by any means, but it may cause a few snorts and chuckles in the Erin family:

"Kindly give the enclosed vote to Uncle Joe Faassen. I'd vote for Pat Barnes except for the simple reason that he's Irish (are you?).—Mable Mapes, Akron, N. Y."

Well, Pat, what are you laughing at?

Some day WEAf may take down another cup. Anyway—

"I am sending you my ballots for my favorite announcer, Mr. Phillips Carlin of WEAf. McNamee is my very favorite, but as he is not eligible, I cast my vote for Phil.—Mrs. Alice Moe, Erie, Pa."

Final arrangements for the presentation of the beautiful gold and silver trophies have not been completed. However, following precedent, the winners will be awarded the honors at the Chicago Radio show. As in the past the cups are fashioned in the shape of a microphone. The name of the winner and the occasion are engraved on the side.

Owing to the deadline closing date of the contest, the standing of the others could not be determined before going to press with the October issue of Radio Digest. The final vote for all contenders will be given in the November issue of the magazine.

AXE DESCENDS AND 17 STATIONS CEASE

COMMISSION SWINGS INTO QUICK ACTION

Hearings for Changes in Power and Wave Lengths Will Begin in Early October

MEMBERS of the Federal Radio Commission, returning to Washington from a general inspection about their respective districts, will soon begin a series of hearings and endeavor to make such readjustments as may seem advisable.

It is expected the approach of cold weather will disclose clashes and heterodyning, not noticeable in the summer time. A complete calendar has not been prepared to date. But the first hearings on the program are scheduled as follows:

October 5—Application of Station KLDS, Independence, Mo., for a change of frequency from 1,260 k.c. to 890 k.c. and an increase in power from 1,500 watts to 5,000 watts. Stations notified: WHB, WOQ, WJAX and KNX.

Application of Station WCOT, Providence, R. I., for a change in frequency from 1,330 to 1,130 and an increase in power from 50 to 100 watts.

October 7—Application of Station WBAW, Nashville, Tenn., for an increase in power from 100 watts to 10,000 watts. Stations notified: WCAT, WBBL, WABZ, WABY, WABW, WFKD, WFBE, WDOD, WLCL, KGCA, KFJB, WEBE, WFBC, KFEL, WIOD, WRAM, WFBZ, KWLC and WMAV.

Application of Station WLBX, Long Island City, N. Y., to share time with WNJ and WGCP on 1,070 k.c.

Seventeen Stations Dropped

The first important move on the part of the returning commissioners was to swing the ax on seventeen stations that had failed to apply for renewal of licenses. They were as follows:

KFIQ, Yakima, Wash., Dr. I. M. Miller, 100 watts, 1,440 kilocycles, 208.2 meters.

KFVN, Fairmount, Minn., Carl Bagley, 100 watts, 1,310 kilocycles, 228.9 meters.

KFWH, Eureka, Cal., F. Wellington Morse, 100 watts, 1,180 kilocycles, 254.1 meters.

KFXH, El Paso, Tex., W. S. Bledsoe, 100 watts, 1,240 kilocycles, 241.8 meters.

KGES, Central City, Neb., Central Broadcast company, ten watts, 1,470 kilocycles, 204 meters.

KOLO, Durango, Col., Gerald K. Hunter, 5 watts, 1,500 kilocycles, 199.9 meters.

WABR, Toledo, O., Scott High school, 50 watts, 1,070 kilocycles, 280.2 meters.

WCBH, Oxford, Miss. University of Mississippi, 100 watts, 1,240 kilocycles, 241.8 meters.

WCOM, Manchester, N. H., City of Manchester, 100 watts, 1,260 kilocycles, 238 meters.

WDBK, Cleveland, WDBK Broadcasting company, 250 watts, 1,320 kilocycles, 227.1 meters.

WEAL, Ithaca, N. Y., Cornell university, 250 watts, 620 kilocycles, 483.6 meters.

(Continued on page 23)

PICTURING BROADCAST ACTIVITIES



MANY is the time you have heard "Markel's Society Orchestra" announced from the WJZ broadcasting station in New York. You may have written an applause or two. At least you have said to the other members of the family, "These boys know their wah-wahs."



PRESENTING Herbert Lee Koch, the organ wizard at WHO, Des Moines.

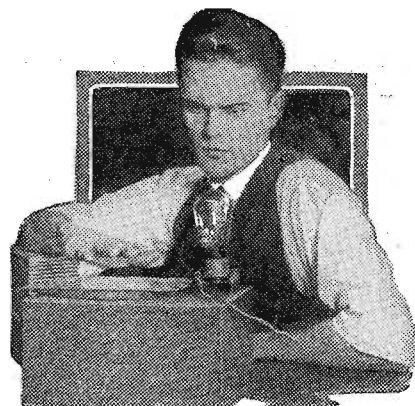

ONE wiggle of D. D. Knowles' little finger and a needle on the Thermionic Microammeter beneath his hand will throw forty-eleven fits. It measures electricity.



"HER beauty of stature and voice are as matched impedance," said the eloquent engineer of WAIU, Columbus, O., speaking of Miss Rose Graham (above). "And what more could anyone say?" asked Don Bernard, director. Miss Graham is contralto in the popular Telling Trio.

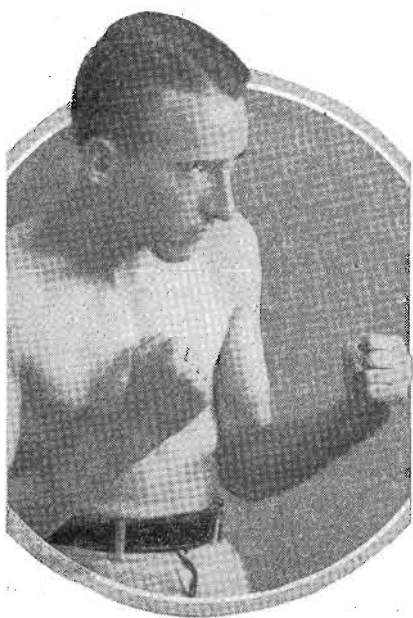

"FIGHTIN' BOB BROWN," who broadcasts challenge from WGR, Buffalo.



REAL fireside atmosphere makes Dan Casey's "Fireside Hour" at KPO, Los Angeles, a cozy number on the program. There's a real fire in the hearth, two friendly dogs, books, a pipe and a comfy chair—sweet papa! Pretty soft for Dan!



WALTER MAL-LORY, "Vagabond" tenor at WCCO, Twin Cities, Minn.



A. D. RING, WEAF engineer, ringing up the Red Chain from the new WEAF 50,000-watt station on Long Island. This is the last word in great station structures. The antenna masts stand 300 feet high and 600 feet apart. When Mr. Ring pushes the button the impulse shoots through a cable, three exchanges and into New York City.



JENNINGS PIERCE of KGO is a graduate of the University of California and is considered one of the best agricultural experts on the air.



WEAF with its 50,000 watts is small potatoes compared with the new British Post Office station at Rugby, which generates 540,000 watts. Picture shows special plow that turns up a furrow just wide enough to take the wire from the drum, mounted behind.

RADIO PERSONALITIES AND EVENTS



BLUE CHAIN listeners will be happy to know by the above picture that Miss Gladys Rice, whom they have admired as a singer of the Roxy gang, comes up to their visual expectations. She is one of those rare sopranos that mike well.

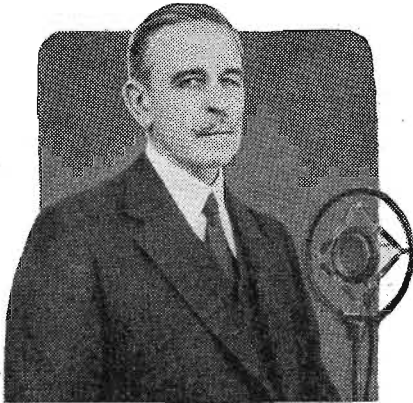

SECRETARY WORK of the United States department of agriculture, sometimes talks direct to the folks on the farm.



THERE'S just one more watt than the engineer allows for when Miss Lillian Watt takes the air from WSM, Nashville. Solemn Old Judge vows she's a peach.



HERE'S a real piano team, Phil Ohman and Vic Arden (right), who percolate through the WJZ net Wednesday evenings.



MISS DORIS LEE tells housewives how to look sweeter and neater via KDKA.

DON LEE is proud of the KFRC Hawaiians. If they're not dyed-in-the-wool Hawaiians you'd never know the difference over the air.

MISS JULIA GLASS, favorite pianist over the Red net.

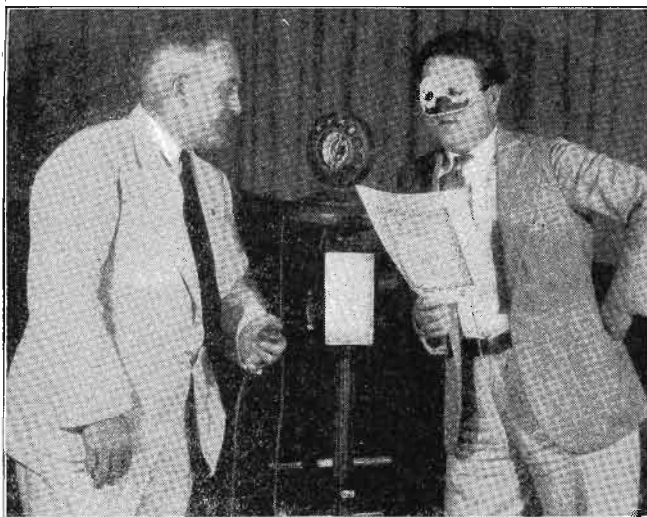

WHO knows how many invisible eyes may be peekin' through the knothole in a microphone? This timid warbler is going to be exposed, right here. He is Gene Austin, "The Man in the Diamond Mask" at WSMB, New Orleans. Our friend with the stop watch (?) is good old Clyde R. Randall, the director.



FUNDAMENTAL principles of the photo-electric cell, talking movies, television and kindred devices were patented by Theodore H. Nakken (above), Cal.



WHEN Pat Einfeld gets on one side of the microphone and Bright Keck on the other there's always somethin' stirrin' in the air around WRVA, Richmond. Wouldn't you like to know what the heck Keck is pointing at? Five keys are sure goin' tu yelp when Pat brings that left down in about one second.

WPG Marine Studio Designed Similar to Luxurious Yacht With Sea Beneath

Norman Brokenshire, Announcer, Takes Listeners for Trip Along Boardwalk and Visit to "Ship"—Peek Through Portholes at Broadcasting

"SHIP ahoy!"

"Station WPG, Marine Studio! Broadcasting from the Atlantic end of the Steel Pier, Atlantic City, New Jersey!"

Behold! Did you ever see such a broadcasting station? A millionaire's yacht—no, it is truly a studio, although it seems to have all the appurtenances for an ocean cruise. Such is the famous Marine Studio of this far voyaging station at the celebrated Atlantic resort.

Norman Brokenshire, mike idol of thousands of listening maidens, portrays the scene most graphically in the course of his broadcast trip along the Boardwalk. He says:

Trip With Brokenshire

"As we leave the crowd we find we are at the junction of Virginia and the 'Walk. Just a step down the avenue is the Hotel Morton, which gives one of the regular features of the WPG programs . . . this marks the entrance to the Steel Pier and the beginning of the busiest section of the 'Walk. The first thing we see is a sign, 'Casino Hall—Minstrels and Photoplays.' We make our way up a short flight of stairs and the motion picture is on. We have seen it, so out we go to the great ocean on Steel Pier.

"We recognize the mammoth music hall. Descriptions over the Radio tell us that it is here the great bands of the country play every season. Sousa was here a short time ago and now it is Edwin Franko Goldman.

"A sign points the way onward to the WPG Marine studio and solarium. That's a good idea—let's go out and see just what a broadcasting studio is like! About a quarter of a mile in the general direction of a transatlantic flight brings us to a vessel—a ship—well, a yacht, to be more exact. Yes, it certainly looks seaworthy. Let's go aboard. Naturally we'll go right up this gangplank—be careful, please, and watch your step. Up the gangplank we go. A crowd. It's a typical Atlantic City crowd, pleasure bent, well dressed, orderly—yes, they are peeking.

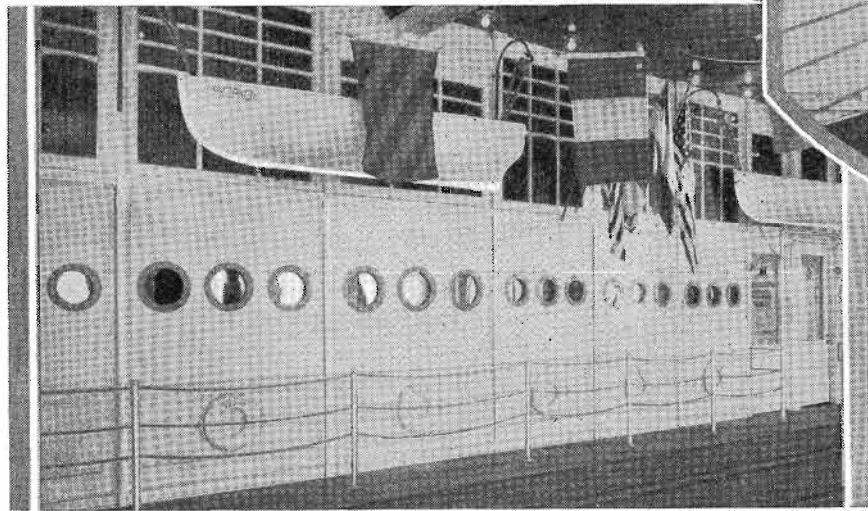

They are peeking through a row of portholes into the interior of the ship. Rather brazen, possibly, but everybody else is doing it, so we'll just peek through, too. Oh! The studio is inside. They are broadcasting. But, inasmuch as we are regular listeners and all that, I think we can do better than peek through the portholes. Let's try the door—there, where the port and starboard lights are shining. We must be very quiet as the door opens to avoid any disturbance that might go out on the air and spoil what's going on. I'll ask first . . . May we go in? Thanks. Now we'll open the door very quietly. Everybody quiet!

Only Rehearsing

"That was pretty; did we intrude? Were you broadcasting? Oh, just rehearsing. Oh, I see, for the program next Wednesday night. We'll tune in. Thank you. And so we make our way from the only broadcasting studio that is located over the ocean. Out again into the crowd that is always between the studio and the ballroom, for in there they dance to the music of Ted Weems and his Victor Recording Orchestra.

"Let's see if they are playing now." Brokenshire's voice gives way to the music of the orchestra before he resumes his descriptive journey. Then he continues: "You see, the beauty of this dance hall over the ocean is, that if you get a little warm, you make your way out here to the very end of the Steel Pier, nearly 2,000 feet from the shore, and what a breeze, what crisp salt air! How invigorating, refreshing, restful! There is music

here, too, the music of the waves as they dash against the pier pilings." The voice

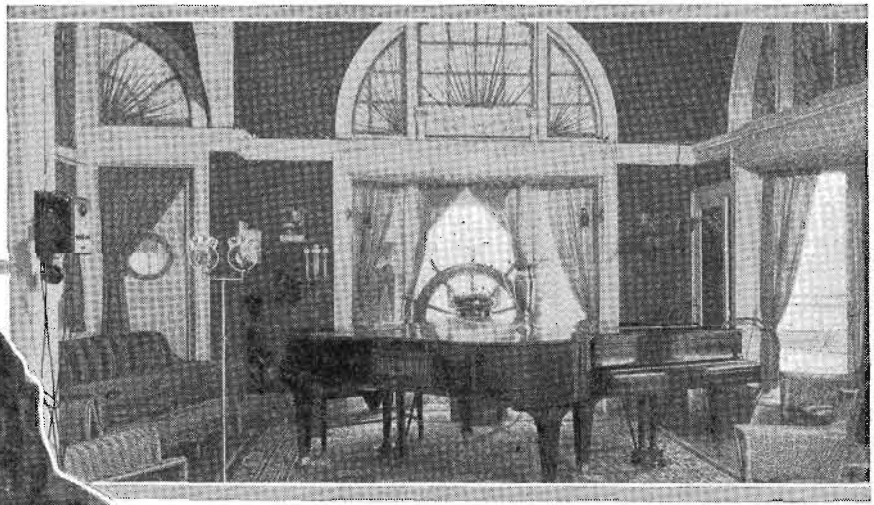

De Luxe cabin in WPG Marine studio (above). Marie Sundelius (left), Metropolitan Opera prima dona, one of the WPG distinguished artists.

WOW PIANIST LIKES MUSIC ALL THE TIME



Marie Kiény, WOW Pianist

MARIE KIENY, charming pianist and assistant program director of Radio Station WOW at Omaha, has won for herself the title of "Nebraska's most musical girl."

"Music hath charms," quoth petite Marie laughingly, "and also harms. Some day it will be the end of me."

She arises from sweet dreams of music at an early hour, and after a hasty breakfast tackles the keys on the piano in her home. Marie is conscientious and therefore insists on two hours of practice each day.

This done, she is prepared for a day of teaching. At noon she is interrupted by a brief luncheon. She is now in full swing of her daily musical activities. As the sun sinks into the horizon she dons her hat and coat and hies for the WOW studios. There she grabs her files and spends an hour or two talking music to Radio entertainers and answering endless inquiries pertaining to choice of selections, time of auditions, proper studio dress appearance, and the like.

Suddenly something goes wrong with the program. An artist has failed to appear on schedule. Marie dives into the music rack and brings out a copy of a masterpiece by Bach, Rachmaninoff, Rubenstein, or what have you, and she fills the gap, noblesse oblige, and how!

This is likely to continue until ten or eleven each evening.

Wendell Hall in Merger

Wendell Hall Music Publishers has acquired all assets of the former Dellwoods Music House, organized by Wendell Hall in 1917. In effecting this deal the Wendell Hall Music Publishers' catalog has been increased to sixteen publications and Mr. Hall becomes sole owner of all rights to his numerous song hits.

New Code of Ethics

M. F. Flanagan, executive secretary of the Radio Manufacturers' Association, has compiled a written code of ethics for the Radio dealers, which is available at the Chicago office of the association, 32 West Randolph st.



Above is the gangplank entrance to the unique Marine Studio of WPG, municipal broadcasting station at Atlantic City. At left are portholes where visitors may observe artists at work.

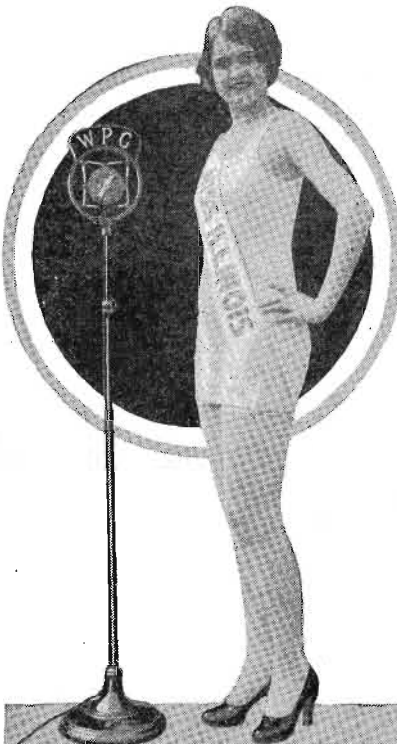

WHEN MISS ILLINOIS finally stood alone as the queen of American beauty she was so happy she almost wanted to cry. No girl from Illinois ever before had won the title of "Miss America"—and so many had tried! So Lois—her private name is Lois Delander and she lives in Joliet—accepted an invitation to tell the folks about it over WPG.

subsides again and a swish-wash-roll-lll is heard as the microphone is lowered to the water's crest.

Norman goes for the eight miles of the Boardwalk, but we'll stop here, because we thought you'd like to get a bit of the atmosphere of the remarkable WPG—"World's Play Ground"—broadcasting station.

Each September finds WPG a particularly attractive center. All the nation turns eyes and ears toward the Boardwalk. There Miss America is chosen as fairest of the fair. Miss Lois Delander of Joliet won the honor this year for Miss Illinois.

WPG belongs to the municipality of Atlantic City. Its modern equipment and technical facilities make it possible for listeners in Europe frequently to hear the programs broadcast there. An interesting reception room with conveniences and continuous entertainment are provided for the welcome of guests at Atlantic City. The director is Edwin M. Spence.

U. S. Radio Leads

Frequently the question recurs, "Where does the United States stand as compared to other countries in broadcasting?"

The latest figures available show that there are approximately 1,100 broadcasting stations in the world. Of this number over half are located in the United States. Of the 13,500,000 receiving sets scattered over the world about 6,000,000 are located in the United States. American made apparatus both for transmission and reception is unsurpassed, according to the sales reports from all parts of the world.

Big Radio Audience Follows Grid Games

Famous Sports Announcers of Stations Plan Broadcasting Usual Graphic Play-by-Play Football Reports

“SEVEN—eleven—ninety-nine!”
Watch 'em go! Hot dog! Twenty—thirty—forty yards! Whoopee! Atta boy! Touchdown! Touchdown!”

Can't you just see those hard muscled huskies crouching, leaping and smashing through to victory?

The football season is under way. Greatest enthusiasm ever known in the history of the game. If you can't knock off to squeeze into a seat on the sidelines you can get a Radio whack at two or three games of an afternoon any Saturday. And it's almost like being there in person the way the bright young sport announcers hand it to you over the air.

No question about it, Radio has been the salvation of many a waning sport in the past few years—not to intimate for a minute that football ever could be classed in that category. But every year sends out a new grist of graduates and out of that grist there is a varying survival of those who retain an enthusiastic interest in college and university sports.

Gate Man Sees Gain

The man at the gate has been able to observe that during the last three and four years the out-school interest and attendance has increased from fifty to seventy-five per cent. There have been a few outstanding heroes who pulled, of course, but the bulk of this growth undoubtedly comes from interest aroused by hearing the games over the air.

So the football season of 1927 starts with a rush from Cambridge to Berkeley and all in between. The big university games of the East will be heard over the leading chain stations. It is more than likely that the most important games on the Pacific coast will be relayed through to the rest of the country. Jack Keough, famous sports announcer at KPO, Los Angeles, already is on the job—“It's a pass! It's a pass! There he goes! Around left end—he's still going. . . .” That's Jack. He's vivid. Nine of the most important Pacific Coast Conference games will be reported through KPO this fall and winter.

Keough Covers Pacific

The games will include those played at the University of California Memorial stadium, Stanford stadium, Los Angeles, Seattle and Portland. KPO also will broadcast any post-season games between the champions of the West and the champions of the East.

In the central states the greater part of the interest will center in the games of the Big Ten Conference and the inter-sectional alliances. There are a dozen good announcers in this area. Outstanding, perhaps, are Quin Ryan and Frank Dahm of WGN, Chicago Tribune station; Hal Totten and Harry Beardsley of WMAQ, Chicago Daily News; Shorty Fall of the Chicago American and Carl Menzer of the University of Iowa.

William Hedges, Radio editor of the Chicago Daily News, says of his team:

With Hal and Harry

“When the football team from the University of Oklahoma comes to Chicago on October first to engage Coach Stagg's Maroons on the Midway, Hal and Harry, the famous team of football announcers of station WMAQ will be on hand for the fourth consecutive year to portray University of Chicago gridiron struggles for the hundreds of thousands of fans scattered throughout the middle west.

“As in years past Hal and Harry will broadcast every game in which the University of Chicago team engages, including out of town games with Ohio State at Columbus on October 29th and the Uni-

versity of Illinois, at Champaign on November 12th.

“Because University of Oklahoma won the championship of the Missouri Valley last year, the first game of the season takes on additional interest. Later on the Maroons will entertain the University of Pennsylvania on Stagg Field in their sec-

ond and last inter-sectional game of the season. Six of the eight games are with conference teams and on the outcome depends Chicago's chance for winning the conference championship. Coach Stagg says this year's schedule is the hardest in thirty-six years.

“Just as the broadcasts of the baseball games at Wrigley Field, by Hal Totten, resulted in increasing both interest and attendance of the Cubs' games, and necessitated the addition of nearly 10,000 seats within the park, so has the football interest and patronage been increased by broadcasting.

Maroons Overcrowded

“Not only has the University of Chicago not been able to accommodate all



At left WIP announcers following game at Franklin field, Philadelphia. Jack Keough (right) KPO sports announcer.

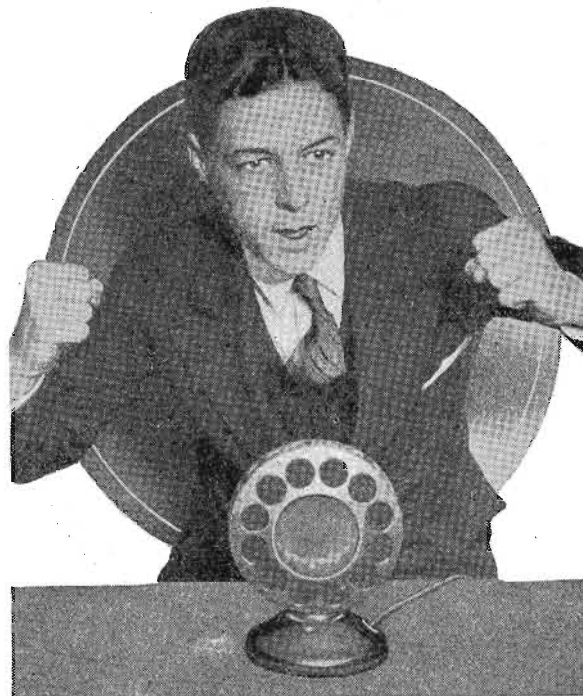

those who sought tickets for the games, but the same condition has existed in other centers, both middle west, east and west. The Chicago school has endeavored to overcome the handicap of limited seating facilities and even now contractors are at work adding thousands of seats for the autumn football customers.

“Fifty-six thousand seats will be available for the spectators of the home games of the Maroons and probably twenty times as many more “invisible spectators” will get a typical football thrill by virtue of the unsurpassed technique which Hal and Harry have developed by their four seasons before the microphone.

“During the course of the football season the fan mail of the two football announcers comes in veritable floods. Letters come from men and women, girls and boys. Nearly all recite the enjoyment which the vivid word pictures of line bucks, end runs or forward passes have given them, and they bear the postmark of many states and many cities, both large and small. Those from sparsely settled communities never fail to express the hope that some day the writer may see such teams of struggling collegians in the Maroon stadium.

Harry Knows Lots

“Harry Beardsley, one member of the announcing team, has long been a student of football. Even before the war, when a student at the University of Chicago, he

At left is Quin Ryan, famous announcer of WGN, who has covered games throughout the mid-west section. Below is Carl Menzer on post of duty at the University of Iowa. He is an outstanding university Radio announcer.

narrated the doings of the Maroons for a Chicago paper. After graduation Harry came to The Daily News and after serving his apprenticeship as an advanced cub rose steadily in his profession and has been made Real Estate Editor. Extremely versatile and with keen descriptive ability, he makes an ideal announcer for the game which he loves so much.

“The other member of the team, Hal Totten, is a Northwestern University man. There is harmony between the boys except on those infrequent occasions when the Wildcats play the Maroons. Then there is partisan broadcasting, but of a kind liked by the fans.

“This year Northwestern does not have a place on the Maroon schedule, so there will be harmony in the tiny booth, high up on the north stand of the stadium, from which the two famous announcers view the plays and enable many, many thousands to attend the games by Radio.”

WGN will feature the professional as well as the university games this year, according to a statement from the publicity department which follows:

WGN Broadens Scope

“For the fourth successive year WGN, Chicago, is to broadcast the majority of this season's important mid-west and inter-sectional football games in which mid-west teams are involved. The scope of WGN's football schedule for the 1927 season was made apparent today, when a tentative list of some of the games to be broadcast was released by the station.

“At least one big inter-sectional clash finds a place on the WGN card yearly, and this time it will be the Southern California-Notre Dame game to be played in Chicago on Nov. 26. Soldiers' Field has been selected as the site of the game, and WGN expects another record audience such as that which listened in on the broadcast of the Army-Navy game from the same spot last year. Coach K. K. Rockne of Notre Dame has already extended permission to WGN to broadcast this important contest, which, judging from the paper strength of the two teams at the present time, is liable to have a direct bearing on

(Continued on page 10)



Harry Beardsley and Hal Totten (right) in the famous WMAQ “football team” of Hal and Harry, who will cover all University of Chicago games this season. They have been teaming on sports announcing for four years.



Broadcasting Art Presents Problem At International Radio Conference

Diplomats from Forty-three Governments Will Convene at Washington to Revise Code of 1912—May Provide Broader Fields for Stations—Soviet Russia Will Not Participate

By L. M. Lamm

Washington Correspondent of the Radio Digest

THE stage is all set here for the International Radio Conference which opens in the auditorium of the Chamber of Commerce of the United States, where the past two national Radio conferences have been held, on October 4, to continue, no one knows how long, for a month, or perhaps two.

This is the first time that an international Radio conference has been held in the United States and this is the fourth conference of its kind to be held. The first conference was called in Berlin in 1903 shortly after one of the Radio companies refused to transmit a part cable message sent by Prince Henry of Germany to President Roosevelt. At that conference an agreement was drawn up but was not signed by the various countries until 1906, when a second conference was held in Berlin.

The third conference was held in London in 1912, which was the last strictly Radio conference ever held and under whose agreements the nations of the world are now working from an international standpoint. It was originally intended to hold these conferences every five years, but they were interrupted by the World War and are just now being resumed. At the present conference the place for the next conference will be decided upon.

Extend Broadcast Band?

It is questionable as to just what the present conference will do which will greatly interest the listener-in in the United States. It seems that one of the points to be ironed out will be the broadcast band of the merchant marine. Indications are that that may be shifted and should such be the case the band for broadcasting within the United States might be broadened somewhat. This would allow an additional number of stations in the United States. The conference, of course, will not deal at all with questions involving the domestic situation, only insofar as it might interfere with the international questions. This might well come up in connection with Canada and Mexico, but no one at this time seems to have any idea that such a question will be brought to the front. There have been so very many changes in the Radio art since 1912, the date of the last conference, that it is expected it will take the delegates a long while to iron out the many changes which are deemed advisable to bring the agreement up to date.

The American government in issuing invitations sent them to forty-two governments, from which Russia was excluded, and all of them are expected to be represented when the conference opens. It had originally been planned to hold the conference in the spring of 1926, but this was found impossible because of the vast amount of preliminary work which had to be done. Every country suggested changes in the agreement and all of these suggestions were tabulated at Berne, Switzerland, into one agenda which had to be studied by the Radio experts of each country, so that when they came to the conference they would be in a position to know just what each change would mean to their respective countries.

Authorized by Congress

The present conference was authorized by congress in the Second Deficiency Act approved by the President, March 4, 1925, and the sum of approximately \$92,000 was made available to defray the expenses.

Subjects to be discussed will include the revision of the International Radiotelegraph Convention and Regulations, signed at London, July 5, 1912, and the discussion of measures for the international supervision of communication by Radio between the large fixed stations; broadcasting, including the handling of press messages; Radio telephony; measures for the elimination of interference; distress messages so as to take cognizance of increased uses and classes of service; Radio aids to navigation, and other purposes for which Radio has been used as a result of the development of the art since 1912.

Thirteen U. S. Delegates

The American delegates to the conference, of which there are thirteen, and two alternates, is headed by Secretary of Commerce, Herbert Hoover, as chairman, with Stephen B. Davis, former solicitor of the Department of Commerce, as vice chairman. All of the delegates are well known to the Radio public and they include, besides the two mentioned, Senator James E. Watson of Indiana, Ellison D. Smith, Representative Wallace H. White, Jr., of Maine, Rear Admiral W. H. G. Bullard, chairman of the Federal Radio Commission; William R. Castle, Jr., and William R. Vallance, as alternate of the State Department; Major-General Charles McK. Saltzman, Captain Thomas T. Craven, W. D. Terrell, chief of the Radio Division, Department of Commerce; Owen D. Young,

Colone! Samuel Reber, alternate; Brigadier-General John J. Carty and John Beaver White.

These delegates are to be assisted by a large number of technical advisers representing the Federal government departments as follows: Irvin Stewart, State Department; Lieut. E. M. Webster and Lieut. R. J. Mauerman, Treasury Department; Lieut.-Col. Joseph O. Mauborgne and Major William R. Blair, War Department; Captain S. C. Hooper, Commander F. H. Roberts, Lieut.-Commander Lowell Cooper, Lieut.-Commander Roswell H. Blair, Lieut.-Commander W. S. Hogg, Jr., and Lieut. A. I. Price, Navy Department; Charles F. Marvin and Edgar B. Calvert, Agricultural Department; J. H. Dellinger, L. W. Austin, W. E. Downey, Arthur Batcheller and Eugene Sibley, Commerce Department; W. N. Brown, Interstate Commerce Commission, and H. C. Moore, United States Shipping Board.

Private Companies Represented

Laurens E. Whittemore will be secretary to the American delegates; Leighton W. Rogers, assistant secretary. Colonel E. D. Peek will be executive officer of the conference, and Bruce Lancaster, assistant to the executive officer.

Many companies throughout the world interested in Radio will be represented.

Distinguished statesmen of the following countries have been appointed to attend the conference: Argentina, Austria, Belgium, Chile, China, Costa Rica, Cuba, Czechoslovakia, Dominican Republic, Egypt, Finland, Great Britain, Canada, Union of South Africa, Guatemala, Haiti, Honduras, Hungary, Italy, Japan, Mexico, Monaco, Morocco, Netherlands, Nicaragua, Norway, Panama, Paraguay, Peru, Poland, Portugal, Rumania, San Marino, Siam, Sweden and Venezuela.



CLEARWATER AND ST. PETERSBURG DIVIDE PROGRAMS OVER WFLA IN CO-PARTNERSHIP



HERE are three members of the John Igram Gang who entertain over WFLA, WSUN and WMBR—the Little Florida Chain. The talent is drawn from the Publix theaters in Tampa and vicinity. Above we behold Miss Emily Day and Hamlet, one of her great Danes. Hamlet has a bit on the stage and makes his bow (wow) on the air. At the left is Miss Irene Reynolds, soprano, who first came into Radio prominence as one of the WJAZ stars.

The best of remote control equipment is being installed in the Art Club in St. Petersburg where the Sunshine studios will be located. The equipment will include mixing panels for eight microphones during studio hours. Feeder lines are being installed in practically every hotel in the vicinity for orchestra and dance programs.

It is understood the two cities will share alike in the division of time on the air. A Piezo Electric Oscillator recently has been installed to insure that the transmitter will be held to the assigned frequency of 820 kilocycles.

FOOTBALL ON THE AIR

(Continued from page 9)

the national football championship for 1927.

"Practically all of the Big Ten Conference schools are represented in the games which WGN will broadcast this fall. Contests involving Illinois, Michigan, Northwestern, and Minnesota are being considered and will probably find a space on the WGN schedule. In arranging its football program for 1927 the station is bending every effort to see that its listeners get the cream of the games to be played in the midwest. The Big Ten schools noted above and Notre Dame all have games scheduled which should provide plenty of thrills for listeners.

Bears and Bulls

"In addition to the collegiate games, WGN this year will resume its Sunday afternoon broadcasts of the season's most important professional games being played in Chicago. Pro football has been making

rapid strides towards popularity, and this year the games of the Chicago Bears and the Chicago Bulls, the Windy City's representatives in the professional pigskin circuits, will be broadcast. George Halas, manager of the Chicago Bears, has already agreed to permit WGN to broadcast the Bears' games which will be played at Wrigley field. Benny Friedman, star quarterback of Michigan last year; Ernie Nevers, Pacific Coast idol, and Red Grange will be some of the stars who are to caper on the pro gridirons this year in games which WGN is to radio.

"When Quin Ryan gets before the microphone for the collegiate games WGN is to broadcast this season, it will mark his fourth year as a football announcer. Quin has broadcast all of the football games WGN has presented in the past, and is one of the most popular sports announcers in the country. Listeners will remember his stellar work at the Army-Navy game last year; the Chicago-Illinois game of two seasons ago, and at a host of other interesting contests.

"WGN's professional football broadcasting will again find Frank Dahm at the "Mike." Dahm broadcast all of the pro games presented by WGN in 1926, and he has his followers among the thousands of listeners who follow the fortunes of the professional teams. Listeners remember best his vivid presentation of the Chicago Bears-Green Bay Packers game last year, which was played in zero weather."

Harvard, Yale, Dartmouth, Columbia will all be adequately covered by such famous announcers as Graham McNamee, Phillips Carlin, Major J. Andrew White, and a score of other veterans of the game. A schedule of the games compiled to the time of going to press with this issue of Radio Digest is published in another column.

Close-Up View of Roxy's Gang "On the Air" in Studio Over Playhouse

Famous Amusement Manager Infuses Own Personality in Radio Programs for Listeners Over WJZ and Blue Network—First Found Fame in Minneapolis

IT IS twilight of a Monday evening—time to light up the panel and pick up Roxy and his gang from WJZ or one of the blue chain stations. Just touch that dial over another hairline. There! Perfect! Now, while we're waiting for the first announcement, you might ease back in that comfy chair while we buzz over for a peek into the broadcasting studio in the top of the Roxy theater to see what's going on.

Roxy, you know, is S. L. Rothafel, who used to run the Olympic picture theater on Hennepin avenue up in Minneapolis, the same theater where Edith Day, famous light opera star, used to sing between pictures. The seeds of greatness seem to have been planted in that theater. After all, folks are pretty much the same on Hennepin and Nicollet in Minneapolis as they are on Broadway and Seventh in New York. And if you know how to be popular in Minnesota you stand a good chance to be popular in New York.

Roxy Climbs Ladder

So Roxy climbed the ladder rapidly in the field of entertainment. It is quite within the cards that he should be equally successful in broadcasting. That's why we are taking this little hop to the studio in that famous playhouse at Seventh avenue and Fiftieth street in the Big Town.

We can see down into the studio quite well from this visitors' gallery. It's really spacious until those Russians begin crowding in. Note the arrangement of the microphone there between the Kimball organ

and the grand pianos. No slackness in the appearance of those musicians, even if they are invisible to their audience. All are smartly arrayed in their formal attire of immaculate white and evening black. The women—ah, that adorable Gamby—are exquisitely gowned. There is no sound. Perhaps the glass partition cuts off the murmur that usually arises from such an assemblage—perhaps the microphone is open. They seem to be waiting. We shall see.

On Their Toes

There is Roxy—vivacious, thick-set and a trifle shorter than those men in the Russian costumes. He has a bit of note paper in his hand. How alert he is! He is going to the microphone. They are all watching him and on their toes.

"Hello, everybody!" You recognize the voice instantly as it comes down from the speaker. Well, well, we have just stepped into the studio and now he is talking about taking another trip.

"We are going to take a trip around the world," says Roxy. "Forget everything. Bid adieu to trouble and care. Join us as we sail out of the home port and set eyes on foreign shores. Listen, the whistle. Say au revoir but

blows and we are off. not good-bye—"

The instruments were poised ready for that word. Arthur Lange flicks the baton and the music swells into the room with the familiar strains. Roxy is aglow with enthusiasm and his beaming face is reflected in the faces of those who are about him. The ensemble flourishes to a close.



S. L. Rothafel

THEY CALL BALTIMORE BOYS HOME

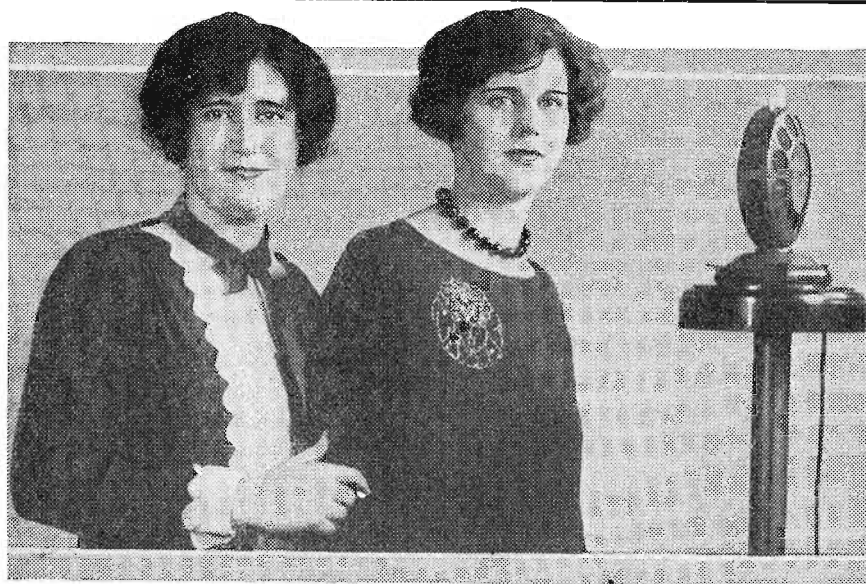

WHEN Friday night comes along and it's time for the Fitz sisters to be heard on the air the boys around Baltimore all come home and tune in WBAL. There's a lure and sweetness to the blended voices of these two that is little short of bewitch-

ing, and there's nothing Mary and Geneva do better than songs of love and romance. For the edification of those who often have heard, but never seen, we produce the above picture of the Fitz sisters as they appear before the WBAL microphone.

An Operatic Aria

Now Harold Van Duzen bursts into an operatic aria and Roxy, the play boy, cannot resist the opportunity, to express it mildly, to "cut up a bit." He gesticulates, grimaces, sighs, while all the gang hold their sides lest they split with laughter, and in the midst of it Roxy notices that a lax member of his troupe is only just putting in a belated appearance. Stern disciplinarian that he is, he frowns, and the deep ridges between his penetrating dark eyes appear, while the merry mood has been interrupted by this infraction of the stern military principles of obedience and devotion to duty which Roxy instills into his organization. But his displeasure vanishes as he hears the stirring melody of "Eli Eli" sung by Gladys Rice in her clear soprano voice vibrant with feeling.

It is nine o'clock now, and Roxy steps before "Mike" and you hear "Good night, pleasant dreams and God bless you!" and he steps from the microphone. The visitors from the gallery surround him questioning, congratulating, asking for photos, autographs, as the gang quietly disperses, to be followed soon by Roxy, who, having been at the helm since early morning, is content to call it a day.

Novice Faces Mike

The "awful" moment has arrived for a novice to sing for the first time into the microphone. She hesitates, but Roxy is there to steady her and put her at ease by a friendly pat on the shoulder and gently turning her face toward the instrument. She performs her part creditably. She starts to turn away. A door slams. The sunny countenance of the director turns to a thundercloud. He summons Douglas Murray and directs that the offender be vigorously reprimanded.

Now the Russians are getting ready. The unhappy incident is forgotten. Roxy takes personal command, guiding the singers through their plaintive tune with inspired feeling. Now comes Maria Gambarelli, the great Gamby and Douglas Stanbury—"papa's pets."

There's a short orchestra number. Roxy, so quick and vital himself, feels it is lagging, and impatiently he steps toward them and begins to infuse his own vitality into their playing and the difference is noticeable.

MIKE CORNERS FAMOUS WIZARD



TRAPPED at last! Thomas A. Edison, America's Beloved Wizard, has squirmed, evaded and dodged the ubiquitous microphone time and again. Somehow he never has warmed up to the idea of Radio Broadcasting. But came the Golden Anniversary of his invention of the phonograph. Something had to be done about it. Three

microphones lined up and got the drop on him. He fished around for something appropriate to say, then recited "Mary Had a Little Lamb," which was the first thing that ever went down on a phonograph record, fifty years ago. And a camera caught him in the act, as you may observe by the above picture.

Broadside Broadcast from U. S. N., NAA Wins Friends in Latin Americas

Sister Republics to South Appreciate Courtesy Programs from Government Station in Washington—All Assist with Representative Artists

THE ether wave is no respecter of national borders. It may pulse from the heart of one country and vibrate in the heart of a dozen others at the same time. Music is the universal language. It stirs the same emotions in the human breast everywhere.

However, there are those who believe international peace would be on a surer footing if the individual listener in the home could understand the words spoken by the speaker or singer across the boundary. In England the British broadcasting company is teaching the subjects of King George to understand the programs across the channel by language courses over the air. This has proved a great boon to the English DX hound, who is just as passionately interested in getting distance as his American cousin across the Atlantic.

Uncle Sam has been carrying on the good work in the western hemisphere un-



Senora Milla Ybarra de Dominguez

der slightly different circumstances. Here the problem is not so intricate, as we have but one dominating language besides English, and that is Spanish. The government has not made a point of teaching North Americans Spanish, but has been sponsoring good will programs by artists from Spanish speaking countries to the south over the naval station, NAA, at Washington, D. C.

Series of Concerts

These programs began with the Pan-American conference last fall and have continued at regular intervals since then with most gratifying results. On September 9 Senora Milla Ybarra de Dominguez, formerly of the Mexico City Grand Opera company, and well known to Radio audiences in the United States, starred in one of the best Pan-

American programs of the series. Mexico, South America and Central America have all been represented.

Silver Masked Tenor of Silvertown Still Held a Mystery to Many Fans

Noted Vocalist Started Career as Song Booster for Music Publishers—Discovered by Radio for Remarkable Voice—Climbs Quickly to National Fame

WHO is the Silver Masked Tenor? The question is still being asked, although the sponsors for his appearance over the WEAF net with the Silvertown Cord orchestra are anxious to hold his identity to the name that made him famous. Many Radio listeners have constantly maintained that the Silver Masked Tenor is only a pseudonym for a celebrity already famous in both hemispheres. They declare that he wishes to keep his true identity concealed for fear that a revelation of the supposed truth would interfere with his professional standing.

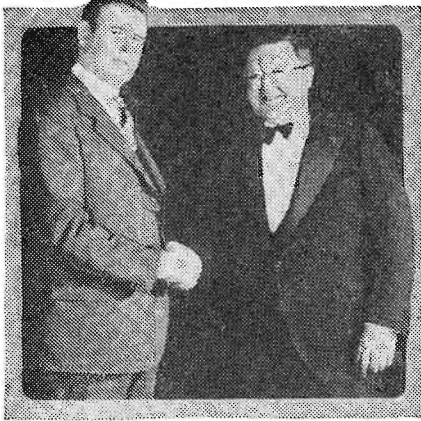

But this surmise is erroneous. In an interview with the writer the Silver Masked Tenor admitted that he had never made any claim to fame before the Radio found him. He was a good singer. The publishers paid him for plugging their songs in theaters or wherever he could. His name was scarcely known beyond the boundaries of New York amusement center.

It was on a mission of this sort that he was "discovered." He had a voice remarkably adaptable for microphone trans-

mission. When the chord orchestra began its series of concerts from the New York studio the Silver Masked Tenor was engaged as a known quantity.

"You would be surprised at the tone of the letters I received," he said. "Again and again I was astounded to be told that I was none other than John McCormick, the famous Irish tenor. I felt highly flattered. But it happens to be my good fortune to broadcast well, and that, I believe, is the secret of my success."

When the orchestra made a recent vaudeville tour across the country Mr. W— rather the Masked Tenor—was received by many prominent people and entertained in the homes of his admirers in the various towns where he visited.

In the picture he is shown being received at the capitol in Pennsylvania and shaking hands with the governor of the state. When he returned to the WEAF studio he was joyfully welcomed and doubtless he has been as happily received "home again" by his millions of friends who know him only as the Silver Masked Tenor.

belong to the Washburn Crosby company, according to the following statement issued by its owners:

"Washburn Crosby Company of Minneapolis, owners of Station WCCO, will from now on be not only owners but sole operators of Gold Medal Flour Station, WCCO."

This announcement was made on September 1st, when the civic associations of Saint Paul and Minneapolis, who for the past three years have cooperated with Washburn Crosby Company in operating WCCO, failed to get together with the owners on a plan for joint civic administration of the Station's affairs.

In the future the station will be known as the Gold Medal Flour Station. Its location will be announced as Saint Paul—Minneapolis, and Washburn Crosby Company plans to operate studios in both cities and broadcast programs from both cities.

In the summer of 1924 Washburn Company purchased the old Twin City Station, WLAG, and replaced it with a new 5,000-watt transmitter and new studios in Minneapolis and Saint Paul. This was done when the civic associations of the two cities agreed, through a subscription of business men, to contribute \$50,000 a year toward the station's upkeep for a three-year period.

That period ended on September 1st, and as a result of the failure of negotiations between the cities and Washburn Crosby Company for the continuance of a similar joint plan of operation, Washburn Crosby Company announced that for the time being they will continue with the station alone.

The Station, it was said, will be operated on a strictly commercial basis, selling time locally and handling programs from both the Blue and Red networks of the National Broadcasting Company.

E. H. Gammons will continue as Manager, L. J. Seymour as Production Manager, and Ray R. Sweet as Chief Engineer.

Commercial radio programs both of a national and local nature have proved so successful in the Northwest in the last two years, officials of WCCO stated, that they believe they will have no difficulty in selling practically all of the available time on the station this year. In fact, it was stated that practically two-thirds of all the station's time has already been contracted for.

The Gold Medal Flour Station, WCCO, will broadcast on a frequency of 740 kilocycles or 405.2 meters.

AMONG the many interesting artists heard over WCCO few have attracted more attention than Mrs. Gertrude O'Neill Ganley, reader and impersonator, whose picture appears at the left. Although Mrs. Ganley traces her descent to the Emerald Isle, she is best known in the radio world for her Scandinavian dialect selections and particularly for her sketch "Tillie at the Photographers."

Twin Cities Lose WCCO to Mill Co.

Station Will Continue to Use Established Features at Both Studios—Gammons in Charge

STATION WCCO, the leading broadcaster of the Northwest with studios both in St. Paul and Minneapolis, will no longer be identified as a community enterprise. It has gone the way of many other stations dependent upon support by local business houses.

Hereafter the Gold Medal station will

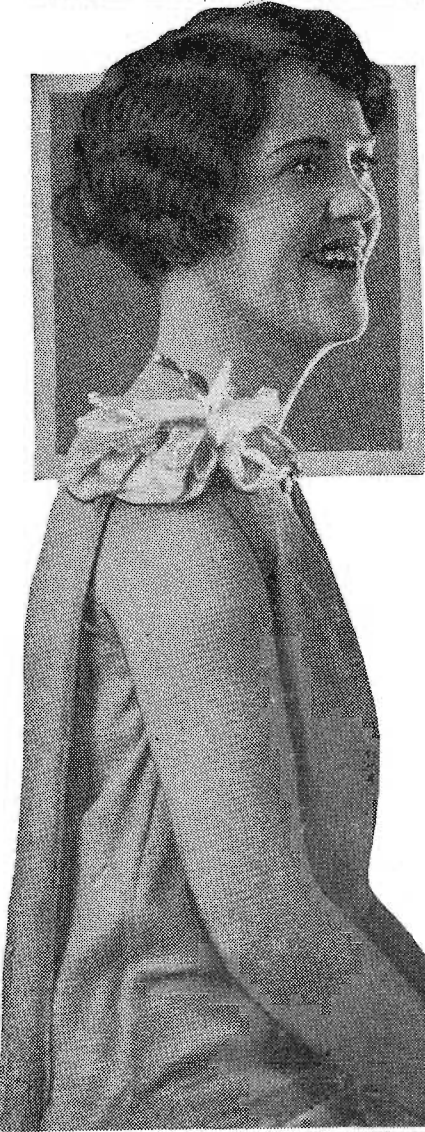

DIRECTOR THINKS RADIO FANS KNOW

MR. FREDERICK SMITH, director of WLW, is a man with ideas. He sends the picture of the two young ladies nestling under the protecting shadow of this WLW microphone and inquires: "Will you ask the WLW listeners to guess who they are? I maintain they will be recognized at once, just by the picture. Ask the listeners to write and tell us who they are. Next month we will give you their names." Batcha can't guess. Whoja suppose? Watch the next Radio Digest for the answer, how many answered and, perhaps, an interesting letter or two.



Aunt Missouri of Southland Croons Lullabies and Sings in Washington

Celebrated Radio Entertainer Brings Joy to Mountain Children With Her Stories of the Sunny Southland—KOMO Growing in Fame and Popularity

THIS entertaining character is known to the listeners of KOMO as "Aunt Missouri." She is not so dark as she looks in the picture but she sounds even darker when the little folks up in the state of Washington settle down before the loudspeakers and listen to her Southern folk songs and bed time stories. Aunt Missouri doesn't need to depend on books for her talks to the children. She invents her own tales and the children say they are the best stories of all.

Children in other parts of the United States have heard Aunt Missouri and many will be surprised to learn for the first time that she is now at home in the "far Northwest."

But she will never forget her childhood in the South. She had many strange adventures which she now turns to good account for the benefit of many other children who know little of the happy hours to be enjoyed in the land where summer days are long and winter just passes by.

Station KOMO is a comparatively young station in the national family of broadcasters but it has made itself known from its home in Seattle to Miami under the skillful direction of G. Donald Gray. It has a number of exceptionally good orchestras serving the listeners—some listeners are remote from the cities and high in the mountains where reception usually is good, where Radio is about all the contact to be had with the outside world for many weeks at a time.

Sometimes Aunt Missouri receives very personal letters from the children in the mountains and for their sakes she often sings some special song or tells some special story to make the day a bit more cheery and happy.

Soon the winter will cut off travel from these distant homes and then she will be called upon to do double duty. She is ready to perform and considers it more fun than giving her impersonations on the stage. She has developed a special technique to make her stories realistic through the loudspeaker.

Following is one of many interesting letters received by Aunt Missouri from a little girl. "Dear Aunt Missouri: I am 11 years old and I want to thank you for the nice stories and the songs. I think the folks in Missouri must have a different language than we do. But I never have been anywhere else than right here. What is a 'possum? I have a young mountain lion in a cage. It was caught in a trap. I would like to read a book with your stories."

Anna Louise Bezdek. The children's hour at KOMO is scheduled for every evening from 5:15 until 5:45 o'clock.



WASHINGTON.—Blue law advocates have petitioned the federal Radio commission to stop all Sunday programs except those of a religious nature. The petition may be carried to Congress.

Everybody Went to Radio Banquet

Dinner Guests Numbered Millions in Record Hook-up—Rival Chain Artists Entertained

HOW did you enjoy the great Radio banquet?

Of course, in the words of a well known Radio manufacturer, "you were there."

It certainly was a grand little party. Probably the most largely attended social function in the history of the world. Imagine the busy society editor flitting about from receiver to receiver among the listeners of the hundred or so broadcasting stations that served the banqueters around the nation. Go a step further and imagine her describing the costumes worn by the various guests who attended via Radio!

From the spick and span of the most formal attire to bedroom slippers, kimonas, pyjamas and nightcaps.

Doubtless the Radio industries banquet will stand as a record for some time as a far reaching hook-up between broadcasting stations. Doubtless, too, it was the most extraordinary achievement of co-operative broadcasting on the part of the world's leading stations.

Night of Revelry

It was a glorious night of revelry, with the most expensive talent singing, playing and cavorting for the joy of Radio listeners, great and small, in homes of luxury, hall bedrooms, farm houses, roadside camps, dotting the continent from coast to coast and mountain top to mountain top.

Business rivalries were forgotten. Major J. Andrew White, master of cere-

WICC DEALS BAY STATE LISTENERS NINE ACE CARDS

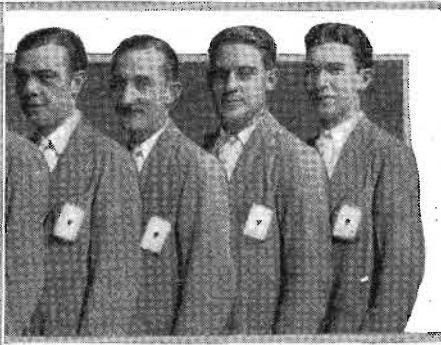

THIS page is our packed deck. Ten aces with one in the hole! In this particular corner we have Captain Julian Webster and his Bay State Aces, who regale Bay Staters and their neighbors from the Bridgeport, Conn., studio. All of these Aces take the air regularly, but the one in the lower left-hand corner uses both his wings and his voice. The Ace in the hole is Captain Webster, himself.

monies, served the National Broadcasting company as unselfishly as he did his own Columbia Broadcasting system. Columbia station listeners enjoyed National artists and National station listeners enjoyed Columbia artists. And for the Radio listener there was no expensive cover charge.

The greatest—yes, undoubtedly the greatest hook-up ever—until the next Radio Industries banquet.

Plan Communications Board

The mills of the gods grind slow, but they grind exceeding small and the mills of federal legislation are beginning to draw all the communications grist into one hopper. At least if the plans of Senator's Watson, Couzens, Dill and Davis materialize the next session will find a bill to expand the present Radio commission into a general communications commission to handle all wire and wireless systems of communication.

CAROLING CAROLINE ON WEF-RED CHAIN



MISS CAROLINE ANDREWS is one of the popular songbirds often heard from the New York studios of WEF and through this station to the many other broadcasters connected with the Red Net of the National Broadcasting company. She also has appeared on the operatic stage and concert work. Her statuesque beauty lends itself charmingly to the Spanish costume shown in the above picture.

WAR ACE BROADCASTS SEASON COURSE ON "AIRPLANES AND HOW TO FLY" FROM KOA



CLOYD CLEVENGER, World War ace, who flies with the eagles around the dizzy peaks that surround Denver, has inspired many Radio fans with a desire to fly. Freeman H. Talbot, enterprising manager of Station KOA, always alert to supply his listeners with every little wish promptly, engaged Mr. Clevenger to come down out of the clouds for a series of practical talks on airplanes and how to fly them. Alexander Airport, nearby, bids fair to do a thriving business in the near future.

WENR-WBCN TO HAVE SUPER POWER PLANT

Insull Electric Interests Contemplate \$350,000 Improvements

MORGAN L. EASTMAN, manager of the twin stations, WENR-WBCN, has advised Radio Digest that the holding company, Great Lakes Radio Broadcasting company, is planning the immediate construction of a new power plant for the operation of a super station near Joliet, Ill. It is expected to have the plant in operation by the first of the year. An appropriation of \$350,000 has been made to complete the work.

The Great Lakes Radio Broadcasting company is a subsidiary of the Insull electric interests, which dominate the central states. The two stations were purchased after the National Broadcasting company took control of the Westinghouse station, KYW, through which Mr. Eastman of the Commonwealth Edison company has been broadcasting since the first broadcasting towers were erected in Chicago. The studio and control room will continue in the Straus building, for the present. Although an increase of power is expected no change is contemplated in the 288-meter wave length.

Thousands Celebrate Air Hero's Day, KMA

EVER since Clarence Chamberlain took the first back seat driver on a hop across the Atlantic, Iowa has been preening its feathers and strutting about among the other states as the cock of the walk. It's big enough job to fly across the ocean, but every family fliwyer driver can appreciate the handicap of a back seat driver. So when Mr. Chamberlain, favorite son, came safely back to his home state, where the tall corn grows, Iowa certainly was proud. That may account for the 10,000 visitors who assembled in Shenandoah when Mr. Chamberlain was a guest at the KMA broadcasting station, owned by the May Seed & Nursery company. He was introduced to the KMA audience and

the visible audience by Mr. Earl E. May. The local merchants called it "Chamberlain Day at KMA."

Incidentally, this first week in October will witness the dedication of the new \$50,000 auditorium at KMA. It will have a seating capacity of 1,000. In connection with the auditorium will be one of the finest broadcasting studios in the United States. There will be a celebration throughout the first week of October. Further details will be published later.

Clarence E. Chamberlain, transatlantic flier, in foreground and part of crowd that attended "Chamberlain Day at KMA" in Shenandoah, Ia. (below).



Broadcasting of Interest to Home Makers

Experts on Air Tell How to Rid Skin of Summer Blemishes

THAT deep coat of tan and those unwelcome freckles do not look so well when the outdoor girl dons her fall clothes, and when she puts on her dainty evening dresses her neck shows a distinct line where the bathing suit ended. Her arms look as if they had a high water mark. Two of the best known beauty experts on the air have come to the rescue of the well-dressed woman with several hints about treating the skin so that it will once more look attractive.

These two recipes for bleaching the skin are harmless remedies which can be made at home, and if used as directed will produce the required results. You can thus become your own beauty doctor.

Take one cucumber, peel and mash well. It can be put through the food grinder, but save every drop of liquid and strain well. To this add the juice of one-half lemon, ten drops of tincture of benzoin and place these in a six-ounce bottle. Then fill with witch hazel. Use this to cleanse the face every night. This amount should last about one week. It will sting a bit when applied, but it will chase tan and freckles like magic and is very good for all types of skin. Try it, you will be delighted.

Doris Lee, KDKA

The simplest bleach that you can use, and one of the effective ones, is Epsom Salts. Make a paste of the salts and water and apply it to the arms, face or other affected parts very often. For the arms and hands a good bleach may be made of one ounce of almond meal, ten drops of tincture of benzoin, and one-half ounce of honey. These three ingredients should be made into a paste and applied.

Much of the freckled and tan condition of the skin may be avoided if phantom powder is used before exposing the face to the sun. Phantom powder which is a non-greasy powder base can be obtained from any number of beauty shops and should be applied from the cake with a sponge. This makes a smooth protecting powder base for your face powder.

Florence Frey, WLW

Health and beauty hints are given by stations all over the United States. No matter how isolated the woman, the latest ideas on how to take care of her hair, skin and general health (which has so much to do with beauty) are brought to her directly through her loud speaker. The talks on Diet and Health at KYA are receiving much attention from Western fans. On Mondays and Thursdays the North Atlantic coast fans receive lessons in beauty through WEEI. WEAF is also doing its share toward keeping the American woman the best looking in the world.

Menus for "Packed Lunches"

By Judith Anderson

Last issue we did not have the space to include the menus for "Packed Lunches" sent us by Mrs. Anderson of WLW. As these may offer some valuable suggestions to mothers, we are giving them to you this month.

Mrs. Anderson has planned these seven lunches to give the mother an idea how the packed lunch can contain the proper amount of nourishment and yet have variety and interest. The most important part of the lunch is the warm drink. She varies the cocoa with creamed soups which contain the same amount of food value.

- 1** Cocoa in Thermos Bottle
Whole Wheat, Chicken and Lettuce Sandwiches
- 2** Sponge Cakes (2)
Apple.
Chicken Noodle Soup in Thermos Bottle
Cream Cheese and Rye Bread Sandwiches (2)
Pear
Cup Cake
- 3** Tomato Soup (Thermos)
Lamb and Lettuce Sandwiches
Small Bar of Milk Chocolate
- 4** Celery Soup (Thermos)
Cold Slaw Sandwiches (2)
Blanc-mange in custard cup
- 5** 3 Oatmeal Cookies
Cocoa (Thermos)
Peach
Sponge Cake
Chopped Ham and Egg Sandwiches
- 6** Potato Soup (Thermos)
Celery and Nut Sandwiches (2)
One Slice of Gingerbread.
- 7** 3 Plums
Cocoa (Thermos)
Brown Betty in Olives
Peanut Butter Sandwiches (2)
Custard Cup

Never include pie in a youngster's lunch and seldom cake. Such desserts are not for children. Furthermore, both pie and cake are hard to pack nicely. A simple cup cake or piece of sponge cake may be used occasionally, but it is a better plan to use some kind of good cookies or rocks.

Betty Crocker, WCCO

Betty Crocker, whose recipes are nationally known to the women listeners, has given us the following recipe for rocks.

- 1 cup shortening
 - 1 1/2 cups brown sugar
 - 2 eggs
 - 3 cups flour
 - 1 teaspoon soda
 - 1 teaspoon cinnamon
 - 1/2 teaspoon salt
 - 1 cup raisins
 - 1/2 cup nut meats, broken
- Cream the shortening and add the sugar gradually.

Children's Hot Lunches

Mrs. Peterson, WENR-WBCN

Mrs. Peterson, whose pioneer work in broadcasting cooking chats over KYW is familiar to most housewives, needs no introduction. She is now broadcasting from WBCN-WENR. Her suggestions for the school child's hot lunch are not only easy to follow, but give a little variety to the noon hour menu. These have been worked out scientifically to give the child just the right amount of nourishment. Too heavy a lunch makes the child sleepy and too light makes him too hungry to concentrate. The lunches, below, are well balanced.

- 1** Tomato Macaroni
Cabbage and Pineapple Salad
Bran Muffins
Grandma's Cookies—Milk
- 2** 4 cups boiling water
2 cups stewed tomatoes or 4 fresh diced tomatoes
1 teaspoon salt
1 cup macaroni
1/2 cup grated cheese
1/4 cup buttered bread crumbs
Add salt to water, drop in macaroni and boil 30 minutes; drain. To macaroni add cheese, tomatoes, sugar and salt and stir thoroughly. Turn into casserole, add buttered bread crumbs and bake in a moderately hot oven (375 degrees) 30 minutes.
- 3** Casserole of Corn and Noodles
Lettuce Salad with Fruit Dressing
Toasted Whole Wheat Bread and Butter
Baked Apples and Milk
- 4** Casserole of Corn and Noodles
2 cups corn
4 tablespoons butter
4 tablespoons grated onion
1 teaspoon salt
1/2 teaspoon pepper
1 cup cooked noodles
2 cups milk
3/4 cup bread crumbs
Add to corn, soft butter, onion, salt, pepper and noodles and stir thoroughly; add milk, stir again and turn into casserole. Cover with bread crumbs and bake in moderately hot oven (375 degrees) 30 minutes.
- 5** Baked Loaf or Patties
Buttered Thin Dry Toast
Sliced Oranges
Ginger Cookies—Milk
- 6** Baked Loaf or Patties
1/2 cup left-over cereal
1 cup cooked carrot or peas or nuts
1 egg
1 teaspoon salt
1 teaspoon onion
1 teaspoon parsley
1 cup whole wheat or bran bread crumbs
To the cereal add egg, salt, onion and parsley. Push carrots or peas through very fine sieve and mix well. If nuts are used put through very finest chopper and mix thoroughly with other ingredients. Shape into loaf or patties. Bake loaf in moderate oven (350 degrees) 35 minutes; patties in moderately hot oven (375 degrees) 20 minutes.

SHORT WAVES

By Marcella

(Continued from page 2)

In answer to your question about the Youngest Baritone, Julia, N. D. Cole of WHO writes the following: "Sorry we can't tell you who he is, but the young man's modesty prevents. He started his musical career to be a concert pianist and one night when he was to accompany Ye Olde Towne quartet, the baritone failed to appear and then for the first time Radio's Youngest Baritone discovered that he could sing. Oh, yes, I almost forgot to tell you that he is a preacher's son and last year was the youngest member of the Chicago 'Student Prince' company."



Mr. Mackin, publicity director of the new Milwaukee Journal station, WTMJ, just happened to see my little note about Nate Caldwell in the last issue. He writes, "To Nathaniel Caldwell's many Chicago admirers who have become anxious about him since he turned up missing in the Windy City, we want to shout that he has struck a good town and is in good company. He has just taken up his new duties as program director of WTMJ." Thanks a lot, Mr. Mackin. I've been swamped with mail.

Imogene is going to be so disappointed when she hears about Cecil P. Underwood, that attractive announcer at KHQ, Spokane. He is married and he has two Radio stars in the family. You can see from his picture that he is just as dangerous to the sight as he is to the hearing. He is tall, slender, dark-haired and blue-eyed. The director of KHQ said he was glad to send me the information and the picture of C. P., because their staff had been snowed under with letters asking about the golden-voiced Cecil.



Was there ever a pair that could entwine their way around the hearts of Radio fans like Ford and Glenn? Every time they leave a station this department is swamped with mail asking where they have gone. Well, this time they hopped up to WJR, Detroit. Miss Indiana wants to know what they are like. Well, Glenn is short and plump and Ford is tall and has dark eyes and an attractive smile. They are both married, my dear, and I have heard their wives are much on the job. In fact, they take turns visiting the boys and keeping away attractive girl fans.

What deep secret would you like to know about your favorite broadcast star? Drop me a note, girls and boys, and I'll do my best to answer here. MARCELLA.

WOMAN'S PROGRAM INDEX (Daily Unless Indicated)

Household Economics, Women's Hour, Etc.

Eastern	Central	Mountain	Pacific
9:30	8:30	7:30	6:30
WWJ (374.8m-800kc), Tonight's dinner.			
10	9	8	7
WBAR (270.1m-1110kc), Modern Housekeeping hour, less work in the American home.			
WCSH (361.2m-830kc), ex Sat.			
WIP (508.2m-590kc), Tues, Thurs, Sat, menu.			
WJR (440.9m-680kc), Mon, Wed, Fri.			
WLW (428.3m-700kc), Woman's hour.			
WTAG (516.9m-580kc), Wed, Fri.			
10:30	9:30	8:30	7:30
WNAC (352.7m-850kc), Woman's club.			
WRC (468.5m-640kc), Mon.			
10:45	9:45	8:45	7:45
KDKA (333.1m-900kc), Radio Chef.			
WLS (344.6m-870kc).			
WTIC (535.4m-560kc), Wed, Fri.			
11	10	9	8
WEAF (491.5m-610kc), Tues, Thurs, Betty Crocker.			
WSB (475.9m-630kc).			
11:15	10:15	9:15	8:15
KDKA (315.6m-950kc), Housekeeper's period, Tues, Thurs.			
11:45	10:45	9:45	8:45
WMAO (447.5m-670kc), Calumet hour.			
WREN (254.1m-1180kc).			
12:30	11:30	10:30	9:30
KFWI (267.7m-120kc).			
KYA (309.1m-970kc), Shopping service, Mon, Fri.			
WEBB (365.6m-820kc), Prudence Penny.			
WMAK (545.1m-550kc), Tues, Sat.			
12:45	11:45	10:45	9:45
WSM (340.7m-880kc).			
1	11	10	9
KGW (491.5m-610kc), Household helps.			
KJR (348.6m-860kc), Prudence Penny.			
KPO (422.8m-710kc), Tues, Thurs.			
1:30	12:30	11:30	10:30
KEX (239.9m-1250kc).			
KOMO (305.9m-980kc), Totem Cooking school.			
WGY (379.5m-790kc), Economics talk.			
2	1	12	11
KFRC (454m-660kc), Mon, Wed, Fri.			
KOIN (319m-940kc), Housewives' hour.			
WGHP (319m-940kc), Home hour.			

Eastern Central Mountain Pacific

Eastern	Central	Mountain	Pacific
2:05	1:05	12:05	11:05
WJZ (454.2m-660kc), Daily menu.			
2:15	1:15	12:15	11:15
KOIL (277.6m-1080kc), Shoppers' aid.			
2:30	1:30	12:30	11:30
KENF (270.1m-1110kc), Kitchen Klatter.			
WGY (379.5m-790kc), Tues.			
3:15	2:15	1:15	12:15
WLS (344.7m-870kc), Homemaker's hour.			
4	3	2	1
WOC (352.7m-850kc), Aunt Jane.			
5	4	3	2
KFOA (447.5m-670kc), Daily ex Sun, Mon.			
6	5	4	3
KOA (325.9m-920kc), Question box, culinary hints, Tues, Fri.			
8:45	7:45	6:45	5:45
WHA (319m-940kc), Home Economics.			

"Aunt Sammy"

Eastern	Central	Mountain	Pacific
10:30	9:30	8:30	7:30
WCSH (361.2m-830kc), WHO (535.4m-560kc).			
10:50	9:50	8:50	7:50
WMC (516.9m-580kc), Mon, Thurs.			
11	10	9	8
WEOA (282.8m-1060kc), WOS (394.5m-760kc).			
11:30	10:30	9:30	8:30
WMAO (447.5m-670kc).			
11:40	10:40	9:40	8:40
WAMD (243.8m-1230kc)			
12	11	10	9
KQV (352.7m-850kc), Mon, Wed, Fri.			
KTES (384.4m-770kc).			
WAMD (226m-1330kc).			
WRYA (254.1m-1180kc), Wed.			
KQW (296.9m-1010kc).			
12:45	11:45	10:45	9:45
WDAF (370.2m-810kc)			
2	1	12	11
KOIL (277.6m-1080kc)			
WASH (256.3m-1170kc)			
3:30	2:30	1:30	12:30
WHK (265.3m-1130kc)			
4	3	2	1
WBCN (283.3m-1040kc)			
WOC (352.7m-850kc)			
4:30	3:30	2:30	1:30
KOIL (277.6m-1080kc)			
WOS (468.5m-640kc), Thurs.			
6:30	5:30	4:30	3:30
KMA (394.5m-760kc).			

Fashions and Sewing

Eastern	Central	Mountain	Pacific
1:30	12:30	11:30	10:30
KFWI (267.7m-120kc), Fashion hints, Thurs.			
1:35	12:35	11:35	10:35
KPO (422.3m-710kc), Fashion critic, Fri.			
2	1	2	1
WOS (468.5m-640kc), Wed.			
6:45	5:45	4:45	3:45
KOA (325.9m-920kc), Fashion review, Tues.			

Health and Beauty

Eastern	Central	Mountain	Pacific
10:15	9:15	8:15	7:15
WCAE (516.9m-580kc), Health talk.			
10:45	9:45	8:45	7:45
WTAM (399.8m-750kc), Tues.			
11	10	9	8
WEEI (447.5m-670kc), Mon, Thurs.			
11:15	10:15	9:15	8:15
KDKA (315.6m-950kc), Doris Lee, Tues.			
11:30	10:30	9:30	8:30
WCAE (516.9m-580kc), Health talk.			
10:45	9:45	8:45	7:45
KFON (241.8m-1240kc), Physiology of beauty.			
KFWI (267.7m-120kc), Beauty hints, Tues, Fri.			
KYA (288.3m-1040kc), Diet and Health, Tues, Fri.			
2:30	1:30	12:30	11:30
KJR (348.6m-860kc), Health talk.			
3:40	2:40	1:40	12:40
KGA (260.7m-1150kc), Dietetic talk, Wed.			
10:40	9:40	8:40	7:40
KHJ (405.2m-740kc), Dr. Phillip M. Lovell, Thurs.			
10:45	9:45	8:45	7:45
KNX (336.9m-890kc), Dr. Robert T. Williams, Tues.			

Gardening

Eastern	Central	Mountain	Pacific
10:35	9:35	8:35	7:35
WCAE (516.9m-580kc), Garden bulletin.			
1:20	12:20	11:20	10:20
KFI (468.5m-640kc), "How and What to Plant," Wed.			
1:30	12:30	11:30	10:30
WGBF (236m-1270kc)			
4:15	3:15	2:15	1:15
WIP (508.2m-590kc), Home Gardening, Mon.			
5	4	3	2
KHJ (405.2m-740kc), Garden talk.			

News

Eastern	Central	Mountain	Pacific
10	9	8	7
WGN (305.9m-980kc)			
10:30	9:30	8:30	7:30
WEBB (365.6m-820kc).			
10:35	9:35	8:35	7:35
WCCO (405.2m-740kc)			
11:30	10:30	9:30	8:30
WHAS (461.3m-650kc)			
11:55	10:55	9:55	8:55
WTIC (475.9m-630kc)			
12	11	10	9
WTAG (516.9m-580kc)			
12:45	11:45	10:45	9:45
KOIL (277.6m-1080kc)			
6:50	5:50	4:50	3:50
KGW (491.5m-610kc)			
2:30	1:30	12:30	11:30
KFON (241.8m-1240kc)			
WGBF (236.1m-1270kc)			
3:40	2:40	1:40	12:40
WCAE (516.9m-580kc)			
3	2	1	12
KGA (260.7m-1150kc)			
5	4	3	2
WGY (379.5m-790kc)			
WHAS (461.3m-650kc)			
6:50	5:50	4:50	3:50
KOIL (277.6m-1080kc)			
7	6	5	4
KFON (241.8m-1240kc)			
KOA (325.9m-920kc)			
WTAG (516.9m-580kc)			
7:15	6:15	5:15	4:15
WCSH (361.2m-830kc)			
7:30	6:30	5:30	4:30
KFOA (447.5m-670kc)			
WSAI (361.2m-830kc)			
7:40	6:40	5:40	4:40
WDBO (288.3m-1040kc)			
8	7	6	5
KOA (325.9m-920kc)			

Reminiscences of Famous Sport Events

Sharkey's Secret Right Hand "Suspense"—How Benny Leonard Was Knocked out on His Feet by Lew Tendler

By Major J. Andrew White

THAT the public has some conception of what it means to broadcast the rapid-fire movements and action of two men contesting for a boxing championship direct from the ringside, and speaking with the rapidity which keeps pace with the fusillade of blows, has been many times evidenced to me in the query: "How in the world can you keep track of the blows as fast as they come?"

Now, of course, that can be answered in one word and that word is "concentration."

In all honesty, however, I cannot say that that is all that is required, because there are many people capable of intense concentration over long periods who still would be unable to translate instantaneous thought into equally rapid verbal expression. But the main thing—I prefer to call it a "trick"—is that you must actually see what you're looking at.

Must See Accurately

Now, the average person does not see what he is looking at, or, if he does, he doesn't see it accurately. The history of the courts testify eloquently to this frailty of human nature in the matter of many thousands of cases on record where two or more eye witnesses will tell absolutely opposing versions of an occurrence at which they were present and presumably fully observant.

Sir Arthur Conan Doyle also illustrated this very particularly in one of his stories where Sherlock Homes asked Doctor Watson how many steps led up to his apartment. Doctor Watson didn't know, nor would the average reader of this article know; and these two instances—which could be multiplied many times—merely indicate what I have said: that the average person does not observe accurately.

In the past six years in which I have been broadcasting fights from the ringside, many thousands of people have expressed to me their reactions in living through the rapid-fire description in such a manner that they sat on the edge of their chairs with the feeling that they were actually present and seeing the entire fracas.

Surprised at Accuracy

Now that is one emotion, and I will deal with that presently; but before analyzing the purely automatic emotional response, it might be well to look at the other version of the listener's reactions. Very often I have heard from dyed-in-the-wool fans that they were astounded at the accuracy with which the blows were called and that they felt they knew right along who was winning the fight—long before the knockout came or the decision, as the case might be.

In questioning many people who have volunteered their appreciation, I have found, however, that none of them seemed to realize exactly what mental processes were necessary to bring about the effect.

Take a typical instance, in the outcome of the Sharkey-Maloney Fight—the contest which made Sharkey important enough to take on Jack Dempsey.

As is always my preferred practice, I watched Sharkey go through his paces in the training workout and noticed that he wasn't using his right hand much. After he was through with his sparring partners, one afternoon I sat in the dressing room with him and talked about this and that, and then brought out this point which I had noticed about the right hand not being used. Sharkey was a little surprised that I had observed it, because none of the other ring critics had mentioned it to him; but he extended his right hand to me and said: "Feel it. It's in perfect shape now and on the night of the battle I am going to use that whip." Well, naturally, when I was at the ringside, knowing that this man was a superb boxer and noting carefully that he was not using his right hand, I felt that when he did something would happen. I let the audience sense this—of course I do not remember the exact words in which I expressed the thought—but I kept them in suspense, letting them know that for some reason or another Sharkey was withholding the use of his right. Well, that is nothing more or less than what dramatists use in the theatre to create "situations." The Radio audience, while not conscious of it, was eagerly awaiting anything I would say when this great boxer should cut loose with that right hand.

Right Hand "Suspense"

Round after round went by and still he hadn't yet used it, but when I finally saw it come over, the words describing the slow tumbled out with great rapidity because I saw his right hand land flush on the "button." It landed on the point of the jaw and I said then, "Wow! That was a peach. The right landed flush on

the jaw and Mr. Maloney certainly knows he got that one!" No sooner were the words out of my mouth than Maloney had staggered across the ring and with knees sagging had dropped his guard. Two quick punches then finished him.

Now, those are the things that the listening audience does not take into consideration. They have their thrill over the fact that I actually called the knock-out blow before the man went down, and the quick verification and the counting

time, conjuring up a terrific mental effort. The point of this anecdote is, that had so that Tendler would not know the damage his blow had done. I said all this into the microphone; and when the bell struck for the end of the round, it made a lot of conversation and added a lot of color to the fight description.

Spectators Missed Significance

Now the general public who were actually present in the arena did not realize what had happened—there were no

RINGSIDE REPORTS BY RADIO SHOVES UP BOX OFFICE RECEIPTS SAYS TEX

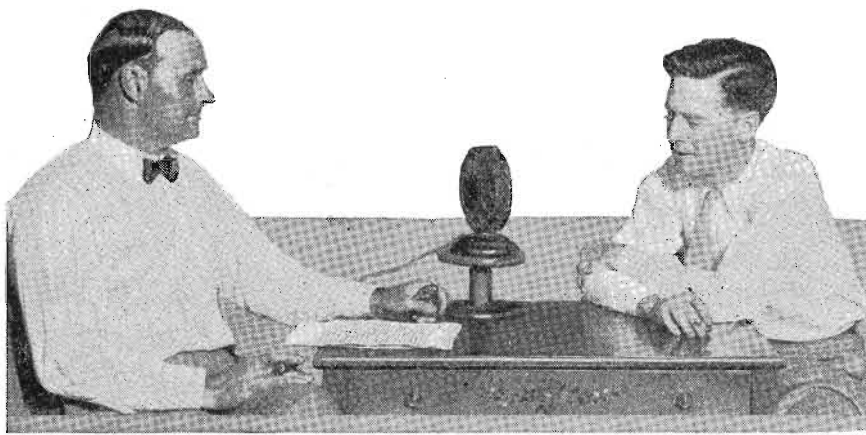

Tex Rickard (at left) has become thoroughly converted to the idea that broadcasting a prize fight helps gate receipts. It was therefore no difficult proposition for Westbrook Pegler, clever sports writer for the Chicago Tribune (right), to inveigle Mr. Rickard to the WGN microphone to tell the folks about the big fight September 22.

out made it an intense dramatic description.

I called this merely a right to the jaw and not valued the blow, the listener would not have known whether it was a terrific finishing smash or just a grazing right jab that would do no particular damage—and there is where we get into the matter of detail. It is an extra task, but one certainly worth while performing, to value each blow as it is struck so that the listener has the opportunity of knowing just how good each wallop is. A fight, as you know, can be won or lost on a single blow, and the spotting of the particular blows that are doing damage and valuing those that are showy but harmless, is the whole difference between the listener considering that he has "seen" the fight or that he has listened to a report of a series of blows struck by each of the opponents.

Must Value Each Blow

If it was not for this quick evaluation of blows, the whole thing would resolve itself into a colorless report, such as comes over the ticker-tape.

Now, then, many people ask me how it is possible to do this. Well, the answer to that is very simple. It merely requires a knowledge of boxing and, coupled with that knowledge, a firm resolution that as a Radio descriptive broadcaster you are not there to enjoy the fight, but are present in line of duty to make it clear to the listeners exactly what is happening.

This can be applied in almost endless detail. For instance, a listener has not thought perhaps of the importance of saying, "Dempsey's back is now against the ropes," instead of merely saying, "His back, etc." The vast difference is in saying that it is Dempsey's back and not just "his," which might mean the other fellow. Then, of course, there is the necessity of constantly keeping in mind that the public is entitled to know how both of the opponents are standing the gaff. A man can look very fresh and still be out on his feet; and the average fight fan doesn't know it, even if he were present at the ringside.

I recall an instance in the famous championship "mill" between Benny Leonard and Lew Tendler held at Boyle's Thirty Acres. Tendler smacked over a terrific hook, which landed flush on the body of Leonard. Now, unless you know boxing, it would be impossible for you to value that blow as soon as it struck. However, I realized that the birdies were probably singing very prettily in Benny's head. I said so. Yet there was Leonard, talking to Tendler and apparently guying him, although the actual words were not audible three feet away. Now the fact was, that Leonard was "out" on his feet, but, being a smart fighter, he was talking to gain

cheers nor were there any jeers. To them apparently a good blow had been struck and apparently done no damage; and yet many months after when I was having luncheon with Tendler at his training quarters he told me that it was right then and there that he lost the fight. He knew he had delivered a terrific smash and that Benny Leonard should have dropped, but when he didn't drop and sassed him back, saying in effect, "Is that the hardest you can hit?" it took all the steam out of him, and from then on he thought he had met his master—with the inevitable result that he lost the decision and fight.

Now there is a lot of fun and a lot of satisfaction when you verify your impressions and find how accurately you sensed the situation, as evidenced in this particular case.

Let me give you another example of how little the public is trained to see what they are looking at.

On the occasion of the Dempsey-Sharkey fight, I undertook to introduce a new element in fight broadcasting by agreeing to appear at the New York studio of the Columbia Chain immediately after the end of the battle and answer any questions which the fight fans might care to ask.

I was rushed from the stadium to the studio immediately at the conclusion of the hostilities and talked into the microphone for some thirty minutes as to what had actually happened when Dempsey knocked out Sharkey. In this description I was very emphatic and very positive that Dempsey had driven three hard rights to the body and followed these with a vicious left hook to the face, landing high on the cheekbone.

Dispute Final Blow

While I was talking the telephone was ringing constantly with questions from Radio fight fans that another announcer's version was to the effect that he had been dropped by a left to the body, and what did I know about that? My answer was a firm reiteration that it was three rights to the body and a final left hook to the face; that I was absolutely positive of it, and so on.

Then they asked me about the foul. I explained that in detail: that it was a physical impossibility for a man to retain his balance with his feet wide-spread apart, as Dempsey stands, and deliver those three right punches low, without going off balance; therefore, I was equally certain there had been no foul.

Well, as all who follow boxing know, these were great controversial points.

When I left the studio that night we had a little midnight supper, and, among those at the table, were two men who had been sitting directly in back of me at the fight. They both expressed amazement

that I was certain it was three rights to the body and a left hook to the face which had finished Sharkey, and in response to their insistent curiosity as to why I was so positive I replied merely that it was my job to be sure of those things; and that whereas I had been working at the fight, they had been enjoying the fight—a very vast difference.

Moving Pictures Confirm

Frankly, they were a little skeptical as to my accuracy and on the way home we bought the morning newspapers to see what the sporting writers said about it. One of them agreed with me on the point that it was Dempsey's left hook which had dropped Sharkey; but none of them mentioned the damaging body blows. Later, the following day, in an evening newspaper, one sporting writer paralleled in every detail the description of what had happened—about which I was so certain—and then the following evening the moving pictures were on exhibition. That settled the point once and for all. It was three rights to the body and a left hook to the face which knocked out Sharkey. Then my companions at the ringside were willing to concede that they had not seen those blows, although they were looking directly and intently at the fighters.

Yet it is just the difference between casual inspection and the intensive concentration which makes or mars a microphone description.

I mentioned earlier that I would deal with the matter of emotional response, that form of intense excitement which sways people who are really doing nothing more or less than listening to words tumbled out of a loud speaker.

I have yet to find anyone who realized that there was a method in describing it which produced that effect—and it all bears upon the observations I have just made in the preceding paragraphs.

Take, for example, the battle of the Sesqui-Centennial at Philadelphia, in which Dempsey lost his championship to Tunney. The newspapers printed a verbatim transcription, taken down by high-speed shorthand reports, of exactly what I said, and this record established beyond dispute that in the very first round the listening public was told that Dempsey was not the fighter he had been and that he was "a hollow shell" of his former self. Now bear in mind, that the listener was tipped off to what could be expected in the first minute or two of actual fighting. That gave the Radio fan a mental picture of the invincible Dempsey not being up to his formerly astounding fighting form, and that there was a possibility that he would be licked. Round after round went by with this repetition that Tunney was away out in front and they were waiting minute after minute for something to happen which would crown a new world's champion. In consequence, when the judges and the referee rendered the final decision, it was an intensely dramatic moment.

Listeners Tipped Off

Now, let's examine this method a little. Had it not been that the Radio fan was tipped off that Dempsey was on the downgrade, he would not have been in suspense during the succession of the rounds that followed. If he had been listening to a mere calling off of blows as they were struck, he might have reached the conclusion that it was a hotly contested battle—and it was that, unmistakably—a rip-roaring contest every minute. But the important point is that the listener knew Dempsey was merely trying. He was aggressively forcing and endeavoring every second to break through Tunney's defense—and it was all very good to look at, and very showy—but he simply wasn't able to damage the Fighting Marine.

Knowing this, therefore, a structure had been built for the listener very much as the dramatist builds his play. It was in effect the theme of Hamlet: that fate was overtaking a man. And if your audience is kept keyed up by the unfolding of the developments with an eventual outcome in sight, they have been "ear witnesses" to a play—a drama.

And, as I said before, I have yet to find the person who realizes that there is a technic in this description other than the rapid-fire translation of sight to thought to verbal expression. There is a lot more than that to it; and perhaps with these few guiding principles set down here for the first time, Radio fight fans in the future may realize in retrospect how much they get through the loud speaker that cannot be reduced to cold type on the printed page in the sport writer's newspaper story the next day.

HOWARD RADIO

Electric!

"So fine! and so easy!"

Thirty seconds to Install



Simplicity Itself! Plug it in the Light Socket —Music before the Delivery Boy is out the door!

RADIO in your home can now be as care-free and convenient as electric light!

Howard Radio *Electric* is your dream of the ideal set *come true*. A single switch—a single control—think of the comfort! All the power comes directly from your lighting circuit—and the new R. C. A. and Cunningham "AC" Tubes do the rest.

PLEASURE—unspoiled by the trouble and muss of batteries and chargers, free from the expense of costly "substitutes"—*Yours at the snapping of a switch!* And whether your Howard be the least expensive or most elaborate model in the line it will be an instrument charming in design and craftsmanship—amazingly wonderful in its mellow reproduction of tone.

The total cost of operating your Howard Radio Electric Receiver 5 hours a day is about 45 cents a month! Write now for the Howard "AC" Catalog which fully describes and illustrates models ranging in price from \$259.50 to \$700. Address your nearest Howard Dealer or

HOWARD RADIO CO., 451-469 E. OHIO ST., CHICAGO

Howard Radio Receivers are licensed only for Radio Amateur, Experimental and Broadcast Reception. They are licensed under patent applications and patents of Radio Corporation of America and associated companies, General Electric Co., Westinghouse Electric & Manufacturing Co., American Telephone & Telegraph Co., and Hazeltine Corporation, owners of the Neutrodyne and Latour patents.

Finding and Fixing Troubles on Your Set

Simple Remedies For Sick Receivers

By James McDonald

TO the great majority of us, a Radio receiver and its troubles are a puzzle, a great mystery, and any ills which may befall it are to be taken care of only by "one of those guys that know something about one of those things." That is only natural of course, since only a small percentage of our hundred and something odd million people are connected with the Radio industry or have Radio as a hobby. But vice versa of course, such things as layouts and copy that are familiar things to the advertising man would be something of a problem to the average Radio repairman.

For some reason, salesmen and sales managers seem to have the greatest horror of radio set trouble, with doctors a fair second and writers third. Most of these men have no difficulty wielding a wicked mashie, bidding a bridge hand intelligently or making a great many of the necessary adjustments on a car, but they certainly fight shy of a Radio.

Like a Code

Now, finding and fixing the troubles connected with the operation of a Radio set is very much like solving a secret code which, incidentally, is not so hard if one knows the procedure. This latter pastime is, as a rule, handled on the theory that the letter E appears in the English language most frequently and that the character used in the code which appears more often is probably E. Next in frequency of appearance is the letter A, then T, and so on.

The Radio set repairman, or expert, follows much the same line. He knows from long hours of association with Radios that one certain difficulty is wrong more often than any other; that, if this particular point is not the cause of trouble, another well-known spot is. Of course it sometimes happens that one can immediately put his finger on the trouble by listening to the reproduction, if the set is working at all. A run down C battery affects the reproduction in a way that the trained ear can recognize, and a well used B battery can be detected a great many times by listening. However, Mr. Average Man cannot do this, any more than he can listen to his car's motor and pick the spot as the mechanic can.

A Friend in Need

Now let us presume that a friend has called up and said, "Jim, this blamed (?) thing won't peep. Be a good fellow and hop over and see what you can do about it.

LOOKING INTO A STORAGE BATTERY. THE WATER LEVELS CAN BE OBSERVED THRU THE FILLING HOLES "X" AND SHOULD BE KEPT AT LEVEL SHOWN BY DOTTED LINE

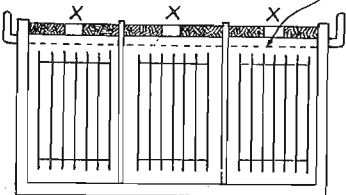

I've got something pretty nice here and we'll have one together afterward." At the first sentence we groan, and at the second sentence we say "Alright," and go over.

The first thing to be checked is the connecting wires from the batteries to the set and those connecting the batteries to each other. There is the greatest source of Radio grief known. Women will dust and move furniture, children will play and men will bump things trying to raise the window or reach the ash tray. On many of the sets of the past two seasons, the wires from the batteries are brought to the set in a cable which disappears right into the "innards." Not much chance of trouble at the set end.

With sets which have binding post terminals, to which the ends of the wires in the cable are connected, we carefully inspect each of the connections because in case of the cable having been jerked, the wire which went taut first may be loose. We reach right in with finger or pencil and touch each one as it may "look" connected but is only lying against the insulation part of the binding post.

Inspect Aerial and Ground

Presuming these are O. K., look at the aerial and ground wire connections. They come in from outside and may have been jerked. Are they O. K.? Alright, now we go to the other end of the cable where it joins the power supply. We will consider first the installation that has B batteries and a storage battery with trickle charger. The majority of sets are still working on this power source, regardless of the blandishments of B and A power unit manufacturers. There should be a solid Red wire coming out of the cable that belongs

on the Pos. post of the storage battery. A solid Black covered wire is intended to go to the Neg. post of the storage battery. Two wires connect the trickle charger to the storage battery if all is correct. Check these.

Another unit has begun to creep into installations called the Power Relay. If the set has one of these in the battery compartment, the "twisted pair" leading from the relay should go to a light socket. The plug on the end of this "twisted pair" may have been jerked from the socket in wall plate, lamp or "twin" socket. If this is found to have happened, it is probable that the storage battery has run down and it will only be necessary to insert the light plug and let the battery charge up. However, presuming this plug was in its place—there are two receptacles in the relay for plugs from the B eliminator and from the A battery. This set not having a B eliminator, check to see that the A battery plug

May Be Batteries

Now we go back to the batteries. It may seem that a great deal of time is being spent on the accessories, but that is correct because that is where 95 per cent of trouble is. The only thing that moves in the set proper is the condensers (in case of Kellogg, the variometers) and very seldom is the trouble in the set itself. A storage battery in the case of 6-volt, 201 type tubes, contains three cells or compartments, each of which has a cap over the filling hole in the top of each cell. These should be unscrewed and a good "look" taken to see how much water there is in the cells. In each one, it should be 1/4 to 1/2 inch over the tops of the plates which can be easily seen within. Do not hold a match over the tops of the cells; get a light over to the battery, or vice versa.

If the water is low, put in enough distilled water to bring the level over the

that may have formed around the tops of many of the test tubes, then examine carefully the little nickel wires that connect the elements of each cell to those adjoining.

Effect of Corrosion

They may have eaten through. It won't hurt to take the time to unscrew the front plate of bakelite and see that the wires leading from certain cells to the various voltage binding posts are O. K. as, if any one of these is eaten through, or disconnected, it is just as serious as if one of the battery-to-set cable wires was off.

Which brings us to the C battery. This is, as a rule, what appears to be a decorated cardboard box about 4 inches long, 3 inches high and an inch thick, with three clips or binding posts on one edge. In many sets this is placed in the compartment with the other batteries and there is a cable wire to be connected to the post on this battery marked minus 4 1/2. A short wire is to connect the other end of this battery, marked "plus" over to the minus terminal of the storage "A" battery. If you have a power tube in the last socket of the set, and three B battery blocks, there will be two C batteries and two cable wires leading down for connection to this unit.

As a rule, again, these are marked with little aluminum tags stamped C 4 1/2 and C 9. In this case, connect the plus end of one C battery to the minus of the big storage battery, connect the C 4 1/2 wire to the other end of this C battery and also connect this other (minus 4 1/2) end of battery to plus of second C battery with a short wire. The other, or minus 4 1/2, end of second C battery is to be connected to the cable wire marked minus C9.

C Battery Important

If you have a meter, test C batteries to see that they give 4 1/2 volts each. Should you have no meter, stop and try to remember when you got that battery. If about 4 to 5 months ago, it is probably alright, but if it is 8 to 11 months old, or longer, get a new one, or two, as the case may be. The set will run even though it is run down, but the reproduction has been gradually going down in realism, so gradually that it is probable you have not noticed it. The change will be startling when you put in a new one, if the old one was pretty old. It may be that your C batteries are in the same case with the set itself, and secured in a clip. The same

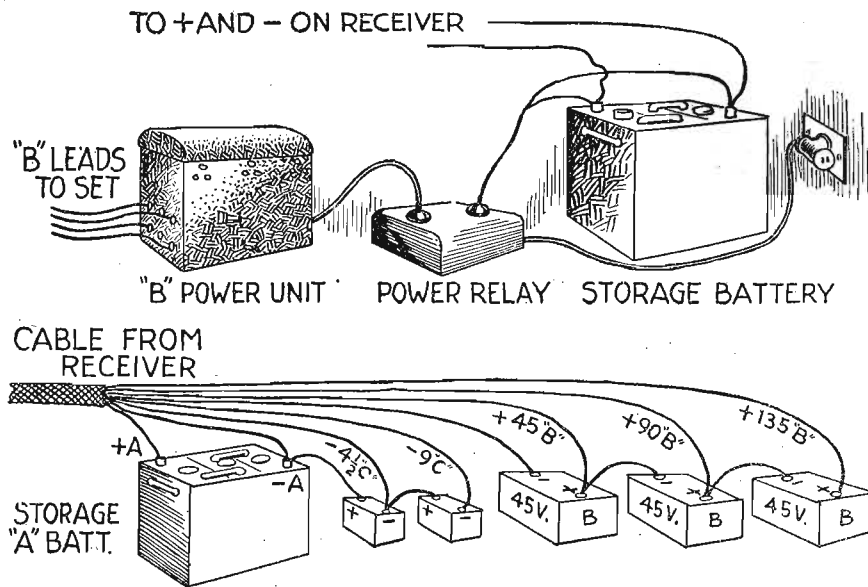

is "in." A few relays have two binding posts for the battery leads, just as easy to check on.

Check All Wires

Aside from the Red and Black cable wires, there will be either three or four other wires for "B" connections. If three, they go to (1) minus B, (2) plus 45 and (3) plus 90. If there are four, they include these three and one for plus 135. The "minus B" goes to that end of one of the B batteries identified with a minus sign. The "plus 45" goes to the other end of this battery where the post has a plus sign, and from this same post a short wire should go to the minus terminal of the second B battery. The cable wire for "plus 90" goes to the other end of this second B block. If the cable has four B leads, there will be another B battery, and a short wire should connect the plus post of battery 2 just mentioned to minus of battery three, while our "plus 135" wire goes to the plus post of this third battery.

All this takes quite a while to read but only a few minutes to actually do. Occasionally, the cable has no minus B wire and a short wire connects "minus B" of the first B battery to the storage battery, and, due to movement of the batteries while the owner has been testing them, this wire is frequently found disconnected or loose. Of course, if any of these wires are found loose or disconnected, our search is over and the rest of the evening can be devoted to some other amusement, but, if the trouble has not been found, we carry on.

How About Tubes

Next in line for inspection come the tubes. The knob labeled "filament" or "rheostat" or "battery" is turned up and down as we closely watch the tubes and, close to the bottom of the glass part of each, one can see whether each tube lights up or not. If all but one of them does dim and brighten, another should be borrowed from the "fellow across the hall" and tried in the socket. Still no results? Alright, now put back the original tube and replace each tube in turn with the borrowed tube which we know to be good. It is very probable that the set will suddenly come to life when one of the tubes is replaced by our newcomer and the answer is "a new tube."

The next step in this "looking for trouble" is the speaker. If outside of the Radio set cabinet, the cord may have become jerked and one of the cord terminals pulled loose from the speaker or set. If the horn is adjustable, try turning the adjusting knob while set is "on"; if a cone, examine the lock screw at the point where it holds the driving rod to the tip of the cone.

tops of the plates. If you live in a city or good size town, stick to distilled water because the chlorine and other purifiers put in will not do the battery any good. If in the country or small town, clear well or stream water will be all right.

Now look at the trickle charger. The majority of these are of the electrolytic type; that is, they have a solution of water and something else, in a glass jar. The level at which the solution should be kept is indicated on the jar and, if liquid level is below this point, add distilled or pure water. If this solution gets down too far, the charger does not "do its stuff" and the battery runs down without getting replenished.

Does Tube Glow

If it's of the tube rectifying type, see if the tube glows with the set off and the "light juice" on. If no glow, the bulb has given its all and a new one is needed. If the charger is of the new dry, and also tubeless type, you cannot, at this point, tell whether it is O. K. All you can do is check everything else, then call the repairman or take the charger to town and have it overhauled. The same remarks just made for trickle chargers apply to the larger chargers whether liquid, tube or dry, and either 2 or 5 amperes.

Now for the B batteries. If they are just beginning to wear out, it is highly probable that the set works O. K. for a few minutes when first turned on in the evening, then goes down in volume with a lot of crackling and hissing, then goes dead.

"Just One Life"

They have just one life to give for their owner and new ones must be purchased. If the set just plain don't work at all, it will be necessary to purchase or borrow a small cheap meter to test the B units. Each one should test around 45 to 46 when new, 40 to 42 after a few weeks of use, 36 to 38 after about two months and when they read anything less, should be thrown out. You may still get programs, but there will be slight distortion and some noise. This testing for voltage is to be done after the set has been running a little while, presuming it still runs at all.

If you have storage B units such as Philco, Willard or Gould, it may be that they have used up the water supplied them. Take a good look at the water level and see that it is up to the proper height as indicated on the glass jars. Use distilled or pure water here, as for the storage A battery and charger.

If you have a storage B unit of the alkali type, wipe off the crust of white powder

THE SHORT SPRINGS SHOULD TOUCH THE LONG ONES WHEN NO PLUG IS IN THE JACK

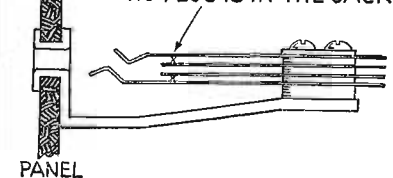

rules apply as above, as there will be short wires leading over to it from the set.

If we seem to go from one part to another and then come back again to look at the first for something else, remember it is because we are looking for the trouble in the order in which it is likely to occur, and the point which we look for the second time does not occur as often as the point for which we looked the first time. This information is being given from the experience of twenty years of growing up with Radio and, honestly, I'm not crazy.

Back to Tubes

I put this in because we're going back to the tubes, even though we've been to them once. However, poor contact between tube pins and socket springs does not occur as often as run down batteries, so we examine tube pins after batteries. Take each tube out of its socket, one at a time so you do not get them mixed, and gently run a nail file across the bottom of each pin on the solder, and on the sides of the pin close to the bottom. You can do this by lightly scraping with a knife blade if you prefer. Anything to get each pin tip bright and shiny.

Before putting the tube back in its socket, reach in the socket and pull up the springs a little with the finger tip (being sure set is off); you can tell when you've really bent them a little. This is for flat springs. If side-of-pin is wiping springs, clean off the inside of each a little, with a knife blade tip. If the sockets are the new type that have only four holes visible, into which the pins fit, take a wooden match, break off the sulphur end, and dip the other in alcohol or cleaning fluid and run it in and out of each pin hole. If you have neither alky or cleaning fluid, use water, which will at least remove dust but not grease.



only
\$7.95
 \$1.00 Down
 Balance
 C.O.D.

MONEY BACK ~ if Not Delighted

At last—an efficient “B” Battery Eliminator for no more than the cost of a set of good “B” batteries! Throw your old-fashioned cells in the ash can. Hook up this Roll-O Eliminator and end the battery nuisance forever. It is a high-grade instrument—compact and durable. Puts new life in your set. Does away with changing and charging of batteries. Gives better reception, sharper tuning. Don’t worry about “B” batteries any longer—install a Roll-O

Eliminator and sit back to the greatest radio pleasure of your life.

Used With All Sets

Works perfectly on any direct or alternating current, giving up to 90 volts and using full wave of the power supply. Hooks up in a moment to any set up to six tubes. Constant voltage assures more power.

Completely Equipped - No Extras to Buy!

What Users Say!

“Marvelous!” “Unbelievable!” “What a Bargain.” Every day we receive scores of letters from users of the amazing new Roll-O “B” Battery Eliminator praising this invention to the skies. It does all that any higher priced “B” Eliminator can do—and more!

I have received the Roll-O “B” Battery Eliminator and I am greatly pleased with it. We did not know we had a good radio till we hooked up your Eliminator. To me it is a 100% perfect Eliminator.
 Detroit, Michigan.

I received the Eliminator and will say that its performance is all I could ask.
 Waterman, Cal.

I have your “B” Eliminator and like it very much. So far it has given me very good service.
 Perth Amboy, N. J.

Recently received a “B” Eliminator. Works fine.
 Akron, Ohio.

The Eliminator is working perfectly.
 Louisville, Ky.

Your “B” Eliminator received and worked satisfactory. Please send me another one at once. Do you give agencies for local counties? I can sell several of these here.
 Zanesville, Ohio.

Five minutes after you receive this Eliminator you can be enjoying its advantages.

Comes to you completely equipped, together with simple, easy instructions. Made to last years. Solidly built in beautifully finished metal case with genuine Bakelite top.

Trickle Charger
\$3.95

Charges “A” or “B” batteries using ordinary house current. Hooked to your “A” battery gives complete “A” power unit. Send \$1.00 with order. Pay \$2.95, plus few cents postage, to postman when he delivers your charger C. O. D.

Use for ten days. If not more than satisfied, return it and get your money back.

10 Days’ Trial!

Now, for no more than the cost of good “B” batteries you can own a Roll-O Eliminator that will make batteries unnecessary forever. Pin a dollar bill to coupon and mail today. Postman will deliver Eliminator to you. Deposit \$6.95 (plus few cents postage) with him. Use Eliminator 10 days. If not delighted with results, return it within ten days and receive your money. Don’t delay. Act quick to become one of the thousands of enthusiastic users.

For
 Real
 Radio
 Joy
 MAIL
 the
 COUPON
 NOW

Send \$1 with this Coupon
 only!

The Roll-O Radio Co.,
 Dept. A-200,
 3rd and Sycamore Sts.,
 Cincinnati, Ohio.

Gentlemen: I attach \$1.00. Please send Roll-O Eliminator to me C. O. D. for \$6.95 (plus a few cents postage) on special 10-day Trial Guarantee.

Name

Address

Town..... State.....

THE ROLL-O RADIO CO.

Dept A-200, Third & Sycamore Sts., Cincinnati, Ohio

Readjusting Receivers for A. C. Operation

Can Use New Power Tubes in Old Sets

By Zeh Bouck

Good news for the listener who wants to convert his old-fashioned receiver into a modern A. C. (alternating current) tube set! By reason of the laboratory research of one manufacturer, this conversion process has been made extremely simple.

Many receivers require only one or two alterations. The accompanying diagram shows how a conventional five tube tuned R. F. receiver, stabilized and volume controlled by returning the R. F. grids through a potentiometer, will look when worked over for A. C. operation with the four prong tubes of the Arcturus Radio Company.

EDITOR.

OFTEN receivers require but slight alterations to adapt them to operation with A. C. tubes. The accompanying diagram indicates the principles of the alteration. Sketch A of Figure 1 shows a conventional five-tube tuned r. f. receiver, stabilized and volume controlled by returning the r. f. grids through a potentiometer. Sketch B shows this circuit worked over for A. C. operation with Arcturus four prong tubes.

While the diagram speaks for itself, it is desirable to stress the salient points associated with the change. All grounds must be eliminated from the filament circuit. The filaments are wired in parallel. While it is desirable though not essential that the filament wiring be twisted or laced, the wires must be close together. All grid returns excepting from the power tube are grounded and the necessary biases (excepting detector) secured by connecting the bias potential to ground and the remaining side of the battery to the plus filament post or posts on the tube or tubes to be biased.

Apply Positive Bias

A positive bias of 4.5 to 9 volts is applied to the grid of the detector tube through a five megohm leak. (The negative post of the battery running to the cathode or plus filament post on the socket.) A grid condenser is used, in the conventional manner, detection still being effected by grid current rectification.

The power tube is biased in the usual way. 22.5 volts is applied to the grid with a plate voltage of 180.

It is impracticable to use a rheostat with A. C. tubes. Also any volume control, such as a potentiometer, which functions by varying the grid bias to the r. f. tubes, will introduce hum on certain adjustments.

Efficient control of regeneration and volume can be effected by placing a variable zero to 200,000 ohm resistor across one r. f. secondary.

Interchangeability

Should it be desirable for any reason to operate a receiver wired for Arcturus A. C. operation from batteries, ordinary tubes may be plugged into the sockets and the set so operated without making any change whatsoever.

Alternating current tubes fall into two general categories, the filament emitter, or "raw A. C." tube, and the filament heater type. The former tube is merely the conventional bulb with the filament designed with the special requirements of A. C. operation in mind and operated from a step-down transformer instead of a storage battery. The filaments are so designed that the fluctuating fields within the tube more or less counteract each other, while changes in the grid circuits are usually balanced out with a potentiometer. The filament heater type eliminates the filament altogether as an electron emitter, the filament acting as a heater for the cathode or emitter which surrounds the filament.

Two Filament Heater Types

The filament heater type of tube is itself divisible into two classes, the low potential high current type and the high voltage low current design. The majority of tubes are of the former design. The high current tube has been hit upon by many designers with the idea of reducing the electro-static field about the filament which is proportional to the voltage drop across it. The low current tube exists through a process of reverse reasoning, namely that it is easier to shield against an electro-static field, of the nature encountered in the tube, than the electro-magnetic field. The shielding of the grid and plate is accomplished by means of the cathode which surrounds the filament heater. Morecroft and Turner have pointed out in the I. R. E. Proceedings for August, 1925, that a metallic sheath about a radiating wire (the arrangement of cathode and heater) offers no impediment whatever to the extension of an electro-magnetic field. However, experimental evidence seems to show that a certain amount of electro-static shielding is effected by such a device.

The Arcturus A. C. tubes fall in this last group. The filament heater operates from a potential of fifteen volts and consumes a

current of .35 amperes. Aside from the electrical advantages of this design the volt ampere characteristics of the filament are of particular convenience to the enthusiast or service man altering receivers for A. C. operation, due to the fact that the ordinary toy step-down transformer may be used as the heater source of current. Special transformers are not required. Also, it is quite practical to operate all heaters in parallel without the use of extra heavy leads, making it possible, in many instances, to utilize the original filament wiring of a receiver.

Standard Base

One side of the cathode is connected to the heater, adapting the tube to the standard four prong UX base, again limiting the number of changes which must be made for A. C. operation.

The Arcturus tubes are made in three types, detector, amplifier and power tubes, all of which are of the heater design. Potentiometers are thereby eliminated from

Arcturus filament consuming 4.5 watts to the candle power with a filament of the usual carbon lamp consuming 3.5 watts per candle power would indicate a theoretical life well in excess of 1,000 hours.

The Arcturus tube also departs from conventional practice in the elimination of any insulating material between the heater and the cathode. It is extremely difficult to eliminate gases from such insulating material due to the fact that during evacuation they are heated only to moderate temperature by conduction and radiation and are under no bombardment.

Arcturus Tube Characteristics

Type	Fila-ment	Fila-ment	Recom- mended	Grid	Am- pli- fication	Mu- tual	Plate
	Volts	A.C. Amps.	Plate	Volts	Con- stant	Con- ductance	Im- pedance
Detector	.15	.35	45	+4.5	10.5	1100	9500
26							
Detector	.15	.35	45	+4.5	10.5	1100	9500
28							
R. f. a. f. 15	.35		90	-1.5	10.5	1100	9500
30							
Power tube	.15	.35	180	-22.5	4.5	1650	2700

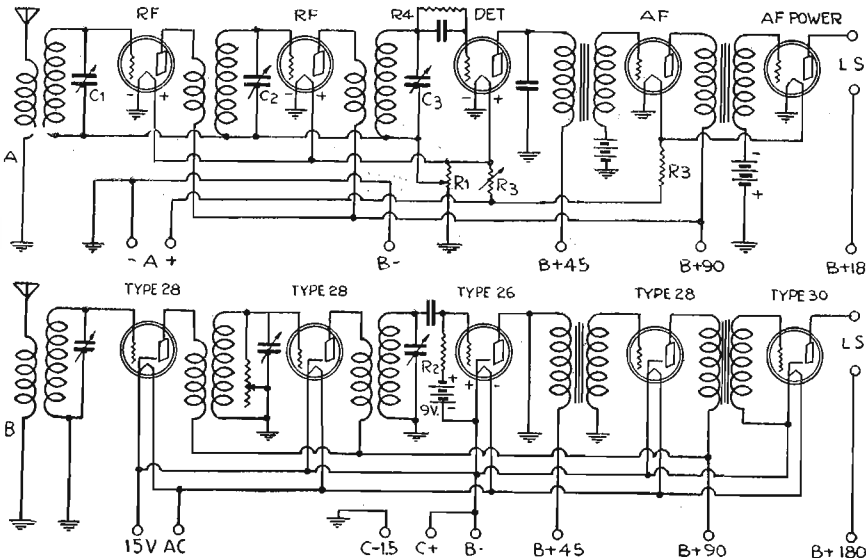

the circuits, and consistent grid and filament wiring may be used throughout the circuit.

The filament heater of the Arcturus tube is of carbon, operating at a temperature considerably lower than that of the usual carbon incandescent light, thereby insuring exceptionally long life to the tube. While the tubes on life test as yet show no indication of approaching the end of their usefulness, comparison of the

Freshman Power Amplifier

OF ALL the recent mechanical and electrical developments of the past few years, perhaps none has undergone so many changes as Radio. Two years ago "volume" and "distance" were all the rage, and a set which could not regularly pull in distant programs with a volume sufficient to rattle the windows, was considered useless.

Today the situation is radically different; Radio sets, it is true, still pull in distant stations better than ever, and with as great a volume, but the determining factor by which a set is judged is the quality of reproduction. This change in public taste is a logical change, and indicates more strongly than anything else the transition of Radio from the class of a novelty to the field of recognized legitimate entertainment. As a result of this demand for quality reproduction, programs from Radio stations have improved to a point where, with a good Radio set and loud speaker, the reproduction in quality and volume is equal to the actual efforts of the artists themselves. Two factors make possible the high quality reproduction: First, improved loud speakers, and second, improved vacuum tubes. The first improvement, loud speakers, may be applied to any set, no matter what the design, or how old, but with uncertain results. Unless the Radio set delivers quality to the speaker, the results will be unsatisfactory. The second improvement, vacuum tubes, may only be used to advantage in sets especially designed for them, and even here, full advantage is not taken of the improved tubes. To take full advantage of the improvements in speaker and tubes, both must be used together.

Recognizing these facts the Charles Freshman Company have developed, and are now offering for sale a combination high quality amplifier and loud speaker housed in a small mahogany table. The combination called the Freshman "Power Speaker" is designed for use with any type of Radio set having one stage of audio frequency amplification or the equivalent. The amplifier in the Power Speaker takes the place of the second stage of audio fre-

quency in the Radio set, thus eliminating the source of 90% of the distortion. The amplifier requires no batteries, it obtains its power directly from the 110 volt 60 cycle house lighting system. As an amplifier tube the CX 210 is used, as a rectifier the CX 216. Full voltage for proper amplification is supplied the power tube, the result being clear, pure reproduction at any volume.

The cone speaker supplied with the Power Speaker is of the diaphragm type, the unit being one capable of properly handling the great volume and fine quality available from the amplifier. In brief, the Power Speaker is a complete audio frequency amplifier unit and reproducer, capable of the best in quality reproduction at any volume.

HOW TO FIND TROUBLE

(Continued from page 17)

Covered All Sources

We have now covered all the sources of trouble which occur in the ordinary run of things. This next one is identified by the following symptoms and has caused the novice a great deal of trouble. The set works great with speaker plugged into the "first stage" jack but gives no program when speaker is plugged into the "second stage" jack, ordinarily used for loud speaker reproduction. The difficulty lies in the "first stage" jack.

When examined, this will be found to consist of four parallel springs, the outer two being somewhat longer and so bent that the speaker plug makes contact with them when pushed in. When the speaker plug is pulled out to be placed in the "second stage" jack, these long springs are expected to bend back to normal and make contact with the shorter springs between them.

After a while, however, they lose their springiness and one of them won't bend back far enough and the result is an "open circuit" in the plate circuit of the first stage of audio amplification and one gets nothing when plugged into the last stage. This is remedied by using a pair of thin-tipped, long nose pliers, getting a grip of

the defective spring close to where it is anchored and giving it a sharp bend toward the next spring. This will make its "normal" position such that it makes contact with the next spring when no plug is in.

Fractured Pig-Tail

Another "tough" one is a broken, what we call, "pig-tail." The pig-tail is a little spiral of flat copper strip perhaps an eighth of an inch wide at the rear end of the condenser shaft. Maybe your condensers do not have these, but rely on contact for the movable plates through the rear bearing. However, if each condenser does have one of these, its inner end is supposed to be anchored to the shaft and the outer end to a pin in the rear or back plate of the condenser.

Incidentally for those not familiar with Radio parts, the condensers are those units in which about nine thin, semi-circular plates are secured parallel to each other and about a sixteenth of an inch apart, and about eight others, also secured together on a shaft, revolve into and out of the first group when you turn the shaft. At any rate, gently lift the outer coil of the spiral of the pig-tail if you have them to see that the inner end is still anchored to the condenser shaft.

B Power Unit

We took up before, the matter of installations using B batteries and storage A battery with trickle charger. Now we'll consider some with different combinations. First, there is a B power unit, giving B current from the light socket. The type most in use has a large jar of liquid, similar to a trickle charger, for changing the alternating house lighting current to direct current suitable for use. The water in this type must be kept up at the indicated level. So, we check that. Others, also very well distributed, have several small jars (4 or 8) and, here again, the water must be kept up.

The only thing which can "go" in the Raytheon type of B power is the Raytheon tube itself and this is not likely to go suddenly but will, after about a year's use, lose its high efficiency and the volume may fall off noticeably. This can only be checked with what is called a "high resistance voltmeter." This instrument is not likely to be around the average set owner's, as it costs \$28 to \$30. The local Radio dealer, or severely bitten Radio fan, should possess one and you may borrow it. You should get 45, 90, 135 and 180 on the various taps of the eliminator.

Fool-Proof Tubes

The B power supplies which use R. C. A. type rectifying tubes can be readily checked, as these tubes, either 216-B or 213, have a filament which lights up when the set is "on." These B powers are pretty fool-proof and have no moving parts, so rarely get out of order.

The great majority of "A" power supplies on the market are nothing more than a storage battery, trickle charger and, sometimes, a relay all in one case. The care of these is, for the various items separately, as given above. A new type has recently gotten into distribution which is a true "A" eliminator, and consists of a rectifying section, a brute of a filter to take out hum, and which feeds directly to the tubes. There is no battery in this combination at all. If your set has this, see that you have filled the rectifying jar with distilled water and the filter part also, but this latter only occasionally. The rectifying jar will need a glass or so of water every few weeks, depending upon how much one uses the receiver and the number of tubes drawing current through.

Beware of Receiver

I do not think it wise to go into trouble shooting in the receiver itself. This is something that mighty few repairmen are able to take care of intelligently, particularly on Radiolas, and if every other possible place for trouble has been gone over carefully, the only recourse is to take it back to the dealer and have him send the set to the factory branch or main plant for inspection. A number of manufacturers put a stipulation in the guarantee that the inside of the set must not have been tampered with or the free repair work paragraph "don't go." Some have so put in the screws so that you would have to break a seal to open the set and then the guarantee is certainly "off."

We seem to have covered everything. Rheostats seldom get out of order; neither do coils or "On-Off" switches. Condenser trouble you couldn't fix if you did find it. If we have overlooked some feature that you and your friends have found causing you trouble and it hasn't been covered here, I'd appreciate your dropping me a line and telling me about it. But, do not send in any sets to be "trouble shot"; your local dealers and Radio doctors are there for that purpose—and I'm not in the business.

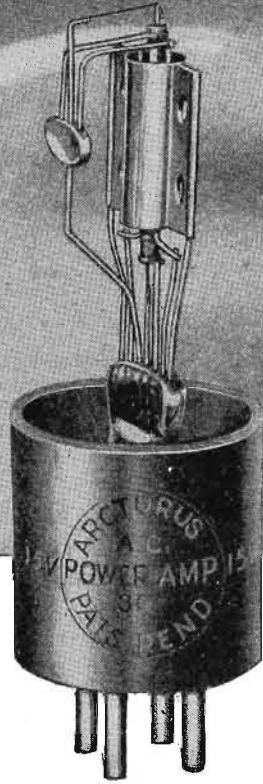

Announcing
THE A. C. RADIO TUBE
 FOR YOUR PRESENT SET
ARCTURUS A. C. TUBES

DETECTOR—AMPLIFIER—POWER

Four Prongs—Fits Present Sockets—For all D. C. Sets

BETTER RECEPTION
MORE RELIABLE MORE CONVENIENT
LESS EXPENSIVE

Now you can have unfailing quality reception, the convenience and reliability of A. C. Tubes, with but a few simple changes, in any D. C. Set.

Arcturize Your Present Set

No matter what set you now own it will pay you to get complete information about this latest development in radio. You will find added satisfaction in the perfect reception you get with Arcturus A. C. Tubes.

Write today for complete information mentioning make and model of your present set.

ARCTURUS RADIO COMPANY, Inc.
 259 Sherman Avenue, Newark, N. J.

How to Build New AC-Super Receiver

Part II—Full Instructions with Templates

By John G. Ryan

IN the first half of this article, published last month, we took up the AC tubes, some of their characteristics and the chief problem in the way of their use in the super-heterodyne receiver. At the end of that first article, I asked that those really interested in this development of Radio dig up a discussion of the super and get themselves fully acquainted with the workings of this circuit before going into the adapting of this Rolls-Royce system to the new tubes. I sincerely hope you have done so, since space does not permit of discussion of the "how and why" of the super-het circuit here.

As pointed out, the problem was that of securing accurate control of the grid bias on the tubes, particularly those in the intermediate amplifier stages of the system. To briefly recall this to mind, a method was shown whereby the plate voltage was varied in relation to fixed grid and filament voltages; then, a second idea was outlined wherein the filament or heater voltage was changed against set grid and plate potentials. Which brings us to the method finally used.

Smith Furnished Idea

For the original germ of the idea for getting this practical control we are indebted to Mr. Smith, engineer of Carter Radio Co., who certainly "knows his resistances" and his Ohm's law. In previous circuits it has been customary to connect filament circuit to B minus and get the grid negative in relation to both with a C battery or potentiometer. If you will study figure 12, which is the circuit drawing for the finished receiver, you will note that all grids go to B minus and that the cathodes (equivalent here to filaments) are isolated by a variable resistance and made more or less positive in relation to the grids and B minus.

This is accomplished for the following reasons. There is a current flowing from the plate to the cathode in each tube, the plate being positive in relation to the cathode. This current is endeavoring to get back to B minus. If therefore, we insert the variable resistance shown, between a cathode and B minus, we can get a "voltage drop" across the resistance and make the cathode positive to the grid, or the grid negative to the cathode, whichever way you want to consider it.

With 90 volts applied to the plate of a Kellogg tube, and a grid bias used of 4.5 volts, there will be approximately 4.5 milliamperes of current flowing in the plate circuit. To determine the resistance necessary, we apply Ohm's Law in the form that Resistance equals Voltage divided by Current. We divide 4.5, the voltage wanted, by .0045 ampere (4.5 milliamperes), which is the current flowing under the conditions wanted, and the answer is 1,000, the value in ohms required to get those conditions. That is for one tube; when there are three, as in the intermediate stages, we divide .009 (3 milliamperes per tube with 45 volts on the plates) into 3.0, the grid bias voltage wanted (approximate), and get 333 as the average value of resistance needed.

Natural Balanced Operation

A natural balance is found in operation,

"B" milliamps, the less "C" volts—Ohm's Law: Voltage equal Resistance multiplied by Current.

Now, getting to the parts used in the set itself. I have chosen St. James super-het kit because, from personal experience, I have found it as selective as any similar group of parts on the market and more so than most of them. The wave length chosen on which to pass signals through the intermediate stages is excellent and signals are found, on the oscillator dial, at two places over only half the range covered by the loop dial, and at one place for the other half. The amplification or voltage gain through these intermediate transformers is high for air core transformers

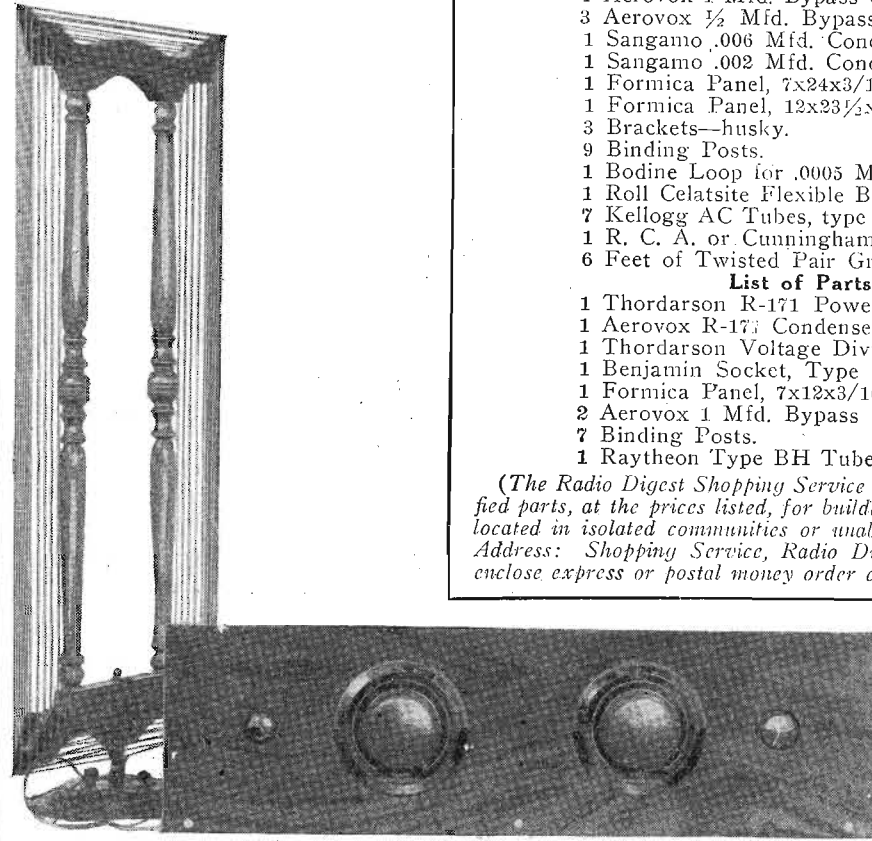

Figure 7—Front view PHOTO. "Controls are reduced to the minimum possible for a super-heterodyne"

and the oscillator is of small diameter, which helps to keep the wave length generated in the oscillator from spreading very far. And, very important, there is compactness without loss of efficiency.

The Silver-Marshall audio frequency amplifying system consists of two of the 220 interstage transformers and an output transformer, type 221. These units have plenty of impedance in their primaries and ample cross-section cores for amplification

The List of Parts Used in AC-Super

- 4 St. James Intermediate Transformers.
- 1 St. James Oscillator Unit.
- 1 St. James R. F. Choke Coil.
- 2 Karas Micrometric Dials.
- 2 Karas Orthometric Condensers, .0005.
- 8 Benjamin Sockets, type 9044.
- 2 Silver-Marshall Audio Transformers, type 220.
- 1 Silver-Marshall Output Transformer, type 221.
- 1 Thordarson Heater Transformer for Kellogg Tubes.
- 3 Carter Type MW-2M Potentiometers.
- 1 Carter Type MW-3M Potentiometer.
- 1 Carter Type M-400 Potentiometer.
- 2 Carter No. 10 Cord Tip Jacks.
- 4 Aerovox 1 Mfd. Bypass Condensers.
- 3 Aerovox 1/2 Mfd. Bypass Condensers.
- 1 Sangamo .006 Mfd. Condenser.
- 1 Sangamo .002 Mfd. Condenser.
- 1 Formica Panel, 7x24x3/16, mahogany.
- 1 Formica Panel, 12x23 1/2 x 3/16, black.
- 3 Brackets—husky.
- 9 Binding Posts.
- 1 Bodine Loop for .0005 Mfd. Condenser.
- 1 Roll Celatsite Flexible Bus Wire.
- 7 Kellogg AC Tubes, type 401.
- 1 R. C. A. or Cunningham Type 171 Tube.
- 6 Feet of Twisted Pair Green Light Cord.

List of Parts for Power Unit

- 1 Thordarson R-171 Power Supply Unit.
- 1 Aerovox R-171 Condenser Block, 8-2-2-1-1.
- 1 Thordarson Voltage Divider Resistor.
- 1 Benjamin Socket, Type 9040, Standard.
- 1 Formica Panel, 7x12x3/16.
- 2 Aerovox 1 Mfd. Bypass Condensers.
- 7 Binding Posts.
- 1 Raytheon Type BH Tube.

(The Radio Digest Shopping Service will purchase all or any of the above specified parts, at the prices listed, for builders of the AC-Super Receiver who may be located in isolated communities or unable to obtain the parts from local dealers. Address: Shopping Service, Radio Digest, 510 N. Dearborn St., Chicago, and enclose express or postal money order covering total cost of parts ordered.)

stations to a split hairsbreadth. The Orthometric Condenser is a beautiful piece of machinery, to anyone who appreciates fine assembly and design. Plate shape, bearings and plate assembly have all been developed to the last degree and they're worth the price.

Benjamin sockets have become just about standard in the Radio set designing field and we have here used the sub-base type because of the saving in height. This factor had to be considered most carefully due to the height of the Kellogg tube and the clip surmounting it. I wanted the base, or sub-base, as you wish, to be about an

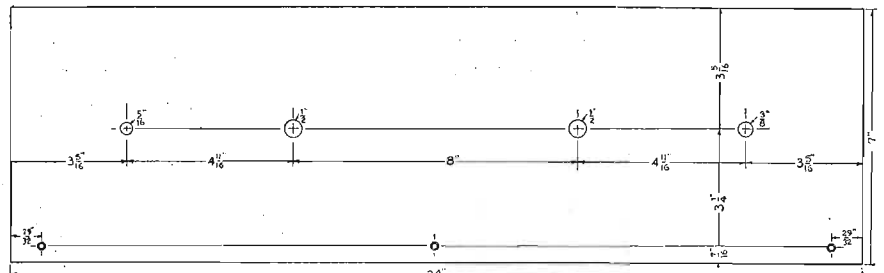

Figure 9—Sub base drilling DRAWING. "If drilled carefully, assembly takes but 20 minutes"

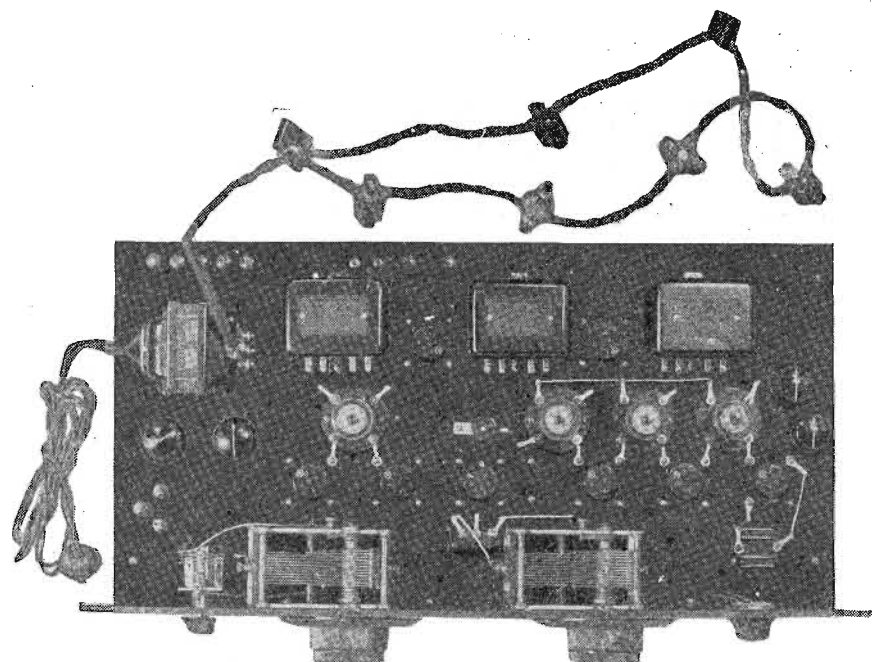

Figure 10—Top view PHOTO. "From this you can easily place the parts"

where all these values reach their proper amount, since Grid Voltage controls plate Current and, in this system, Plate Current governs Grid Voltage. The more "C" volts, the less "B" milliamperes and, the less

of the entire sound range so the final reproduction is natural, well-rounded and "full." It's hard to put analysis of enjoyable reproduction into words but the above phrasing is pretty close.

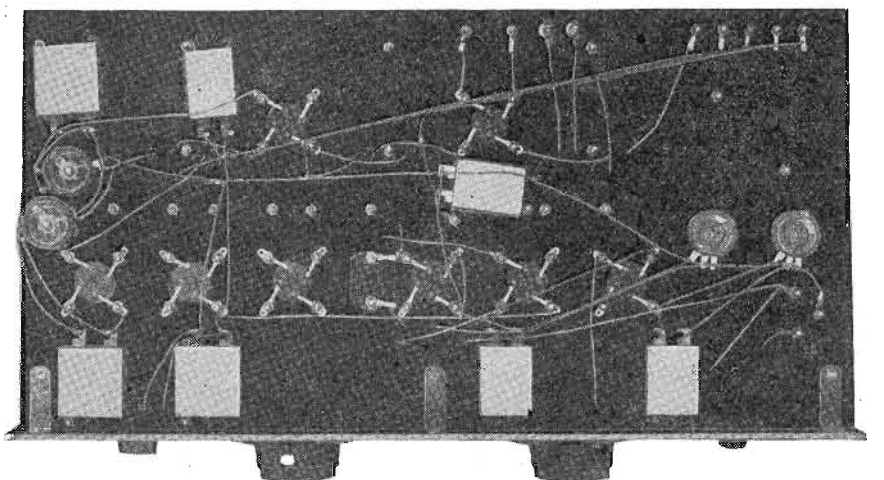

Figure 11—Bottom view PHOTO. "Not a great deal of wiring for an 8-tube set"

Select Karas Dials

On Karas dials and variable condensers I have expounded in Radio Digest before. Granting these dials are not as attractive as the drum type, judged by this year's standards, they still have a precision tuning quality I have found unapproached in any other type dial or tuning control. The action is remarkably smooth and velvety and, on the vernier disc one can "roll into"

inch above the bottom of the front panel, and Benjamin sub-base sockets made this design possible. As to my choice of Kellogg tubes, some of the reasons for this were given in the first article but another important one is ruggedness. Their toughness has been seen demonstrated by dropping the tube, cap downwards, on cement and the internal characteristics remained unchanged. The energy amplification in

these tubes is consistently high as there is a heavy electron emission and ample plate surface.

Prefers Thordarson Power

Thordarson power supply units "get the call," as no other maker seems able to approach the prices and maintain their quality. Thordarson was making transmitting transformers when I was a youngster and their parts have always had an enviable reputation for satisfactory performance. The choice of Carter parts was natural; they have an **engineered** line of resistance units unapproached in completeness. I say **engineered** because Carter units are durable, compact and designed so they can be made in quantity for low price yet hold up under load and dissipate heat thoroughly.

The Bodine loop aerial I can warmly recommend for use with this receiver. It is attractive in appearance, unusual in a loop, is correctly wound for minimum inter-turn capacity and covers the broadcast range of wavelengths with the Karas .0005 mfd. condenser just about right.

Simple Front Panel

I want to call particular attention to the front panel layout which contains about the minimum of controls, of advantage when a receiver is being tuned by a woman. The two large dials, see figure 7, are for tuning, as found on all supers. The small knob to the left is the loop circuit regeneration condenser, controlling both sensitivity and selectivity; the right hand knob is the grid bias variable resistor for the three intermediate stages. That's all there is on the panel; there isn't any more. Carter has just brought out a front panel 110 volt switch for turning the lighting current on and off to the set, but I didn't hear of it until too late for this receiver. It is easy enough to turn the power off at the light socket.

It would have been desirable, but was found impractical, to include the B supply as part of the receiver proper. Due, however, to the necessity for a heater transformer and the size of Silver-Marshall audio units, the B supply must be separate. Since most Radio receivers are placed in the console type of cabinet, having the B power separate is not such a hardship and it goes readily into the "battery compartment." A 4-wire cable and a "twisted pair" connect it to the receiver, the "twisted pair" being used to supply current to the type 171 second audio stage tube, and these wires should preferably be separate from the B current cable.

Not for Novices

Please understand, this is not a set for the beginner. If you have built a set or two before, so you can accurately read diagrams and drill holes, this is the most interesting receiver brought out in any Radio paper for many months. If it would be your first set, I have an idea you'd run into much grief of a type we would be unable to help you on through correspondence. Not that this set is hard to build; just the opposite. But, it must be built right, as trouble would be hard to locate to the inexperienced. As a matter of fact, the wires are shorter and fewer than in all but one of the many supers I've built.

Considering now, the top view photograph, figure 10, most of the units are clearly shown but the variable resistances will need identification. Two are at the left and midway back. That at the extreme left is for the first detector and labelled Q in the circuit diagram, figure 12. Next to it, to the right, is unit P for the oscillator. Going now to the right side of the sub-base we find that in front to be unit S for the second detector and that behind it unit T for the first audio stage. Resistance Q is a 2,000-ohm Carter MW-2M, which will operate with the slider about half way around. It should be understood that once these four base-board resistances are set, they are left alone, just as you would connect a C battery and forget it.

For Steady Oscillation

Resistance P is also an MW-2M which, with 90 volts on the oscillator plate, will function about three-quarters of the way around as a little more than 4.5 grid bias volts is wanted to give steady oscillation on all wave lengths. Resistance R on the front panel, is an M-400 potentiometer and, since the second detector operates on 45 volts plate potential, the resistance S is a 3,000-ohm Carter MW-3M. The first audio stage gets another MW-2M, identified as T. If two of the resistors shown in the bottom view photograph, figure 11, do not agree in appearance with the units you get on my specifications, it is because the MW units were not decided on for all positions until after this view was taken.

The binding posts, reading from left to right, in figure 10 and found in the rear left corner, are B minus, B plus 45, B plus 90 and B plus power. The speaker cord tip jacks are behind the 221 output transformer and the filament binding posts for the 171 tube are next across the rear edge, to the right. The socket which they are behind is for the second audio stage, while the socket further to the right, between the two 220 transformers, is the first audio stage. Going now to the front row of equipment, left to right, the first socket is the first detector, next is the first intermediate amplifier, third is the

oscillator, fourth is the second intermediate, while fifth is the third intermediate. The last socket to right is the second detector.

Use Flat Head Screw

In the baseboard drilling layout, figure 9, you will note a hole in the front right corner, marked to be countersunk from the under side. This is done so that a flat head machine screw can come up through from the bottom into the .002 mfd. Sangamo condenser in front of the second detector and used in the plate circuit of that tube. On the under side, an Aerovox bypass condenser must lie flat against the under side of sub-base and covering the screw head. The oscillator transformer, which I believe Mr. St. James calls an "oscillator," is so placed that terminal 1 is at the left and 2, 3 and 4 proceed across to right, with terminal 5 at the right end.

In the drawing of the circuit, figure 12, I have not put in the complete wiring of

the heater circuits, as it would merely confuse things. The heater transformer is shown below the first detector tube with wires leading to the heater coil in that tube, but the connections to other tubes consist merely in running the piece of "twisted pair" across the top of each tube and its clip, with the insulation removed above each tube, and the wires soldered to the terminals on the clips. My heater cord leads from the transformer forward over the first detector tube, across to the right and, from the second detector, back and slightly to the left to the first audio tube, between the 220's.

Study Top View

The top view photo of the Thordarson B (and C) supply is shown in figure 13. This should be sufficient for its assembly, the base being 7 inches wide by 12 inches deep. The Aerovox condenser block, when placed as shown, makes connection easy, as the filter wires are in proper order for connection to the top of the

Thordarson R-171 unit and two lead out to the resistance strip. The binding posts are B plus power, B plus 135, B plus 90, B plus 45 and B minus. The two to the right carry filament current for the 171 tube in the receiver. Connect them to the set with the before-mentioned "twisted pair" lighting wire. The wiring diagram for this unit is given as figure 14 and is easily followed with study of figure 13.

Too many bypass condensers cannot be used in a receiver of this type, or any set using AC tubes. I have indicated two in dotted connection which are not in the receiver as photographed, but which would be, I believe, a wise addition. I "got away with it" without them, but due to differences in tubes and individual wiring they will probably help many sets. They can be easily secured to the under side of sub-base under the nuts holding down audio transformers. One, as you will note in figure 12, is between terminal 1 of the first audio transformer and the cathode of the second detector. The other

Trickle charge or full-rate charge—

You get either or both with

Westinghouse Rectigon Battery Charger

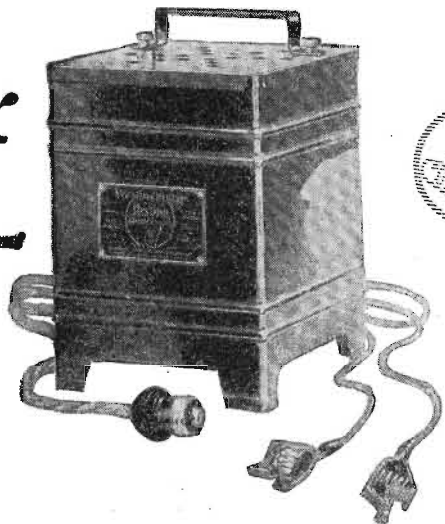

YOUR battery needs two kinds of charging!

Under ordinary conditions, a low-rate charge, "trickled in" during the hours that the set is idle, will keep the battery full of pep. Then, for occasions when prolonged use of the set drains more power than trickle chargers can replace, you need a high-rate charge. The Westinghouse Rectigon gives you *both kinds of charging*. Rectigon charges at a high rate and at a low rate—and it charges wet "B" as well as automobile batteries.

~~\$18.00~~
Now
\$14.00

Rectigon is a Westinghouse product—and you know Westinghouse knows radio. Back in 1920, the first program ever broadcast came from radio station KDKA. Rectigon is safe—uses no acids or chemicals. Long-lived, with no moving parts to break or wear out. Does no harm if you tune in while charging, nor if the light company turns off the power while Rectigon is in the circuit. Get away from charging station expense with Rectigon Home Charger. At your dealer's, now \$14.00.

WESTINGHOUSE ELECTRIC & MANUFACTURING COMPANY, EAST PITTSBURGH, PA.
Offices in All Principal Cities / Representatives Everywhere
Tune in with KDKA—KYW—WBZ

For trickle charging only—the long-lived little Rectox. No guesswork, no acids or chemicals, no trouble. Leave Rectox permanently on charge and replace during "silent hours" the power used during average "operating hours." Two rates of charge— $\frac{1}{2}$ ampere and $\frac{3}{4}$ ampere. At most dealers', \$11.50.



See the Westinghouse exhibit of Rectigons, Radio Instruments, and Micarta Radio Panels at the Sixth Annual Radio Show, Coliseum, Chicago, October 10th to 16th, inclusive: Booth 1, Section AA.



is between terminal 1 of the second audio transformer and the cathode of the first audio tube.

Neat Panel Holes

To cut the 1-inch holes in the sub-base I would advise the 1-inch Stevens panel cutter. This "puts them through" in no time and, if panel is firmly clamped to a board when drilling, puts them through cleanly. The holes indicated for securing the front panel to sub-base are correct for husky little iron brackets wherein the hole in each side of the right angle is 1/2 inch from the outside of the bend. Should you prefer brackets of a different type or size (but be sure they're husky), calculate the drilling holes so that the underside of the sub-base is 1 inch up from the bottom edge of the front panel.

In wiring, I would suggest that you put in the "key" wire, or B minus wire, first, and attach the numerous leads to it. This should simplify things a great deal. This wire is indicated in the circuit diagram as extending from U to V. Changing tubes around to get the best combination will, as usual in supers, help a great deal, but I want to suggest that, in removing clips from tube caps, you insert a pencil's blunt end through the clip hole onto the cap, to hold the tube down, that there will be no strain on the cement holding the tube cap to the glass when you pull off the clip.

Now, please remember, I am presenting this as a set for the experimenter and set builder, and don't write in if the set does not perform 100 per cent on first hooking it up. The cathode resistance values given should be correct for 95 per cent of the tubes used. There may be slight variations in tubes and in your wiring methods that will make necessary slightly higher grid voltages than average in certain sockets. It is probable that by changing tubes around you can find an arrangement where every tube gets just the right values of all currents to perform just right.

Get "Cluck-Cluck"

You should be able to put the first detector into oscillation by turning the mid-gate condenser to the right, and operate just to the left of the click point. You should be able to get the "cluck-cluck"

sary, you can put 130 volts on your oscillator by taking it off of plus 90 and putting in a plus 135 binding post on the rear edge of set for it, and connecting with the 135 volt post on the B power. Sometimes you run into cases where such measures may be necessary, in the first

and eventually became even more perfect, there are going to be more of these AC supers. Either I, or some one else that likes to tackle something new and different, will take this arrangement of units farther along and improve here and there. My advice, however, is to start with the

supplies up to 85 milliamperes of load. The new Cloverleaf is the object of considerable interest by reason of the fact that it is priced to sell for about half what eliminators of equal voltage and current outputs have always sold for. The Raytheon or Q. R. S. 85 mil. tube is used.

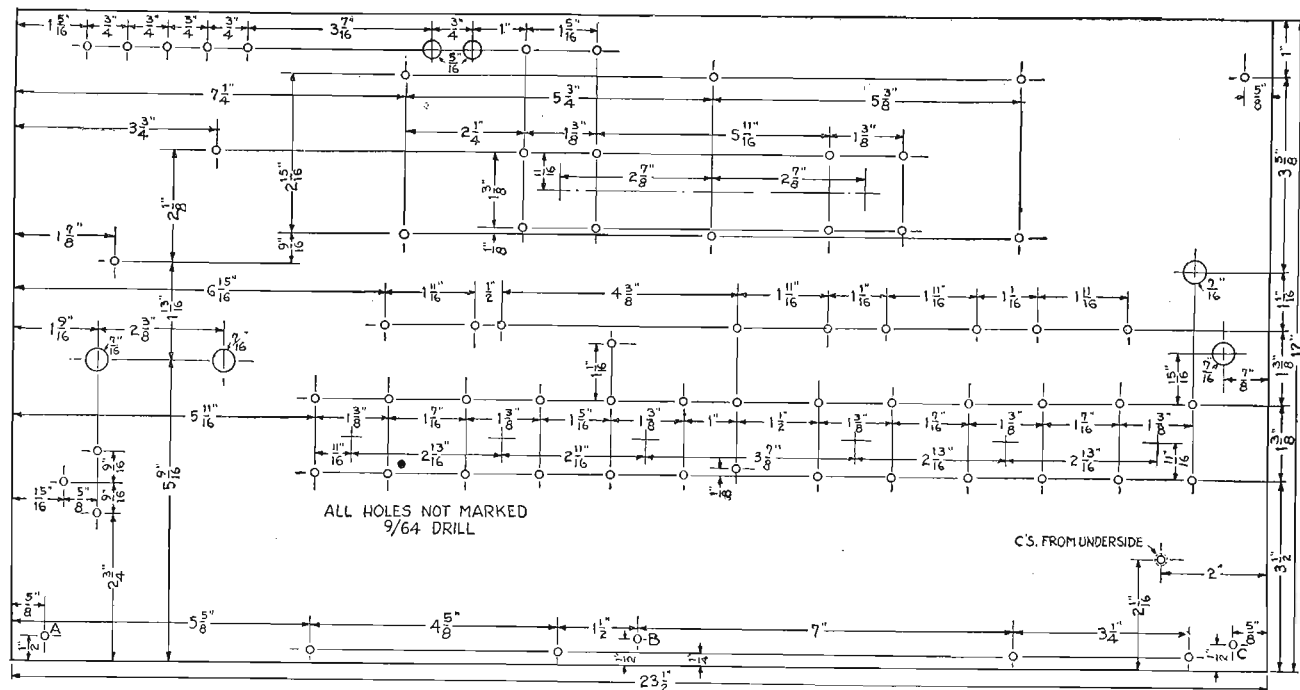

Figure 8—Front panel drilling DRAWING. "Seven holes are all that need be drilled"

case for clarity, and in the second to secure oscillation over the entire range.

Control Difficulties

If you cannot get absolute control over the sensitivity of every tube, even with the cathode resistor slider clear over at the B minus end of strip, a larger value of resistor is needed. Just why such a condition comes about is not always clear, but the added expense of an extra unit (\$0.75 or \$1.25) must be taken as "just

thing now, learn the basic circuit and its characteristics. When you yourself discover points that can be changed for the better, or when some writer comes out with them, you'll know what it's all about, and that is everything in Radio.

Thin B Eliminator

As an aid to unobtrusive beauty required in the modern Radio receiver the Clover-

ELIMINATE 17 STATIONS

(Continued from page 5)

WHBD, Bellefontaine (O.) Chamber of Commerce, 100 watts, 1,350 kilocycles, 221.1 meters.

WKBM, Newburgh, N. Y., John W. Jones, 100 watts, 1,440 kilocycles, 208.2 meters.

WKBU, New Castle, Pa. (portable), Harry K. Armstrong, 50 watts, 1,470 kilocycles, 204 meters.

WTAZ, Lambertville, N. J., Thomas McGuire, 15 watts, 1,360 kilocycles, 220.4 meters.

WREO, Lansing, Mich., Reo Motor Car company, 500 watts, 1,300 kilocycles, 230.6 meters.

WTHO, Detroit, Mich., W. J. Thomas company, 250 watts, 1,370 kilocycles, 218.8 meters.

This reduces the total number of surviving broadcasters to 670, and verifies the prediction of commissioners at the beginning of their labors that the peak number of 732 stations would automatically slump as the result of consolidations and lack of financial support. Probably no station in the list will be missed with greater regret than that of WREO, Lansing, Mich., which has a record of good service and fine programs. Only ten new stations have been granted construction permits.

Expect Secret Radiophone

NEW YORK.—With the completion of the new transatlantic Radio telephone station at Cupar, Scotland, it is believed by telephone officials here that a secret Radio telephone system will be established on a practical basis. This objective has been sought diligently by engineers on both sides of the Atlantic. Technicians of the British Post Office believe they have now

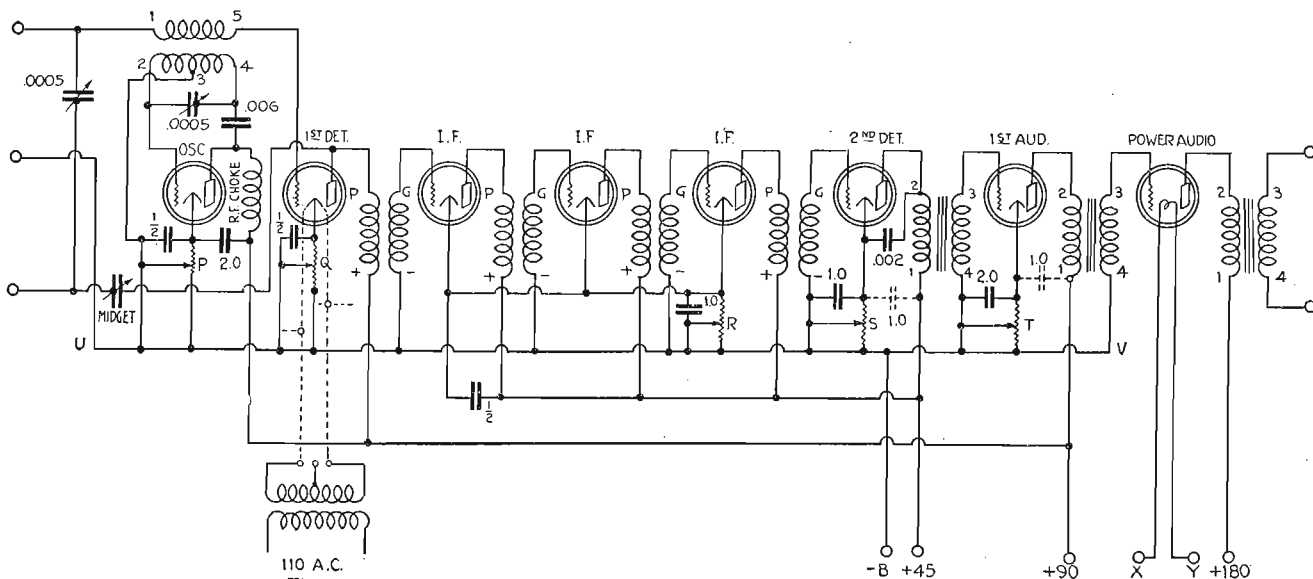

Figure 12—Circuit diagram of receiver DRAWING. "This is a modified St. James hook-up"

when the moistened finger is touched to the stator terminal of the oscillator variable condenser and at any setting of that condenser over its entire range. The second detector should be adjusted for clarity, as it is a potential point for distortion. The first audio stage is not critical, but the further you can operate the slider from the cathode end of the resistance the better, as less B current is drawn. Incidentally, the B power unit uses a Raytheon BH, preferably one of the new ones that can supply 125 mils, as

one of those things." It exists and you cannot help it.

This set, completed satisfactorily, is without question, the best I've had yet. The power is terrific and some builders may prefer, later, to switch to a 210 tube in the last stage with the R-210 power supply. The absence of rheostats, etc., on the panel, once the sub-base units are set, is a decided advance over a mess of knobs which are too much of a temptation to play with. When you don't have to be so careful with "A" current, as the

leaf Lifetime B Eliminator has been designed thin and compact to fit into the back or end spaces of almost any table model Radio set.

This new device offers several other points of interest too. It has no exposed binding posts, and no adjustments for volt-

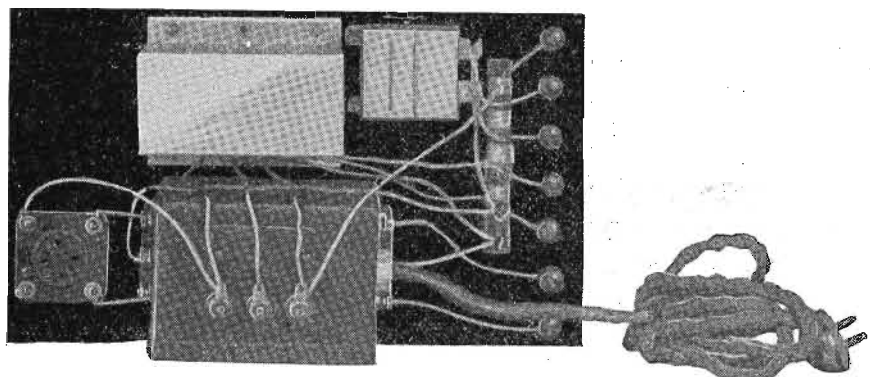

Figure 13—Power supply PHOTO. "Thordarson R-171 Power Unit fits our needs perfectly"

there will be less drop in voltage below 90 and 45.

You can raise the second detector B voltage by shifting its plate return wire (transformer terminal 1) from the plus 45 binding post to plus 90 and, if neces-

designers of the 201A type tube did, a world of power is let loose that makes the reproduction round, full and mellow, even on distance.

Like the famous Flewelling, Roberts and Infradyne circuits that started in one form

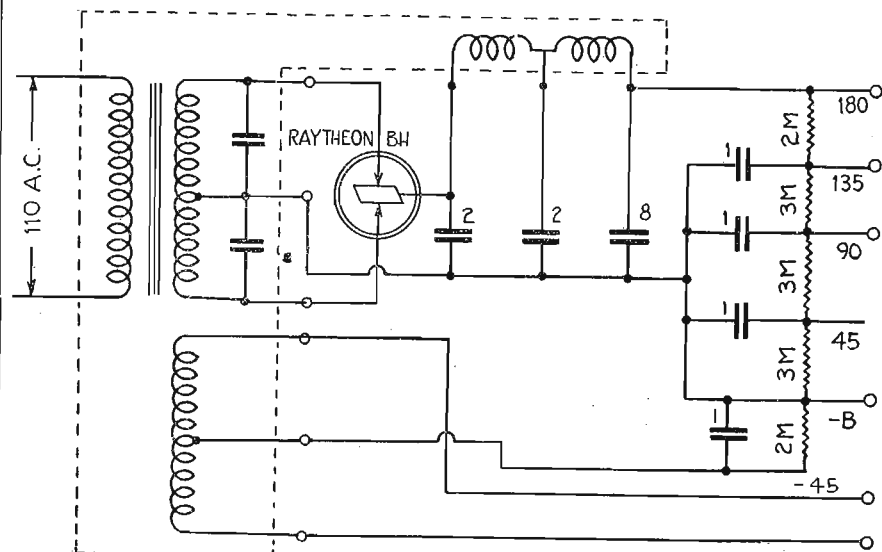

Figure 14—Circuit DRAWING. "Circuit of B Power Supply Unit"

age output, the latter being taken care of automatically. All the common voltage taps needed are provided, ranging from 22 to 180, which voltage the Cloverleaf "B"

solved the problem. The Cupar station will supersede the station at Wroughton, Wiltshire, which is about 80 miles from London.

Radio Digest Illustrated

Reg. U. S. Pat. Off. & Dom. of Canada

Published by the
RADIO DIGEST PUBLISHING CO.,
(Incorporated)
510 North Dearborn Street
Chicago, Illinois
Telephone: Superior 7323

E. C. RAYNER, Publisher

Eastern Office, Park-Lexington Building, 247 Park Ave.,
New York. Telephone: Ashland 8144

Member of the Audit Bureau of Circulations



241
PUBLISHED MONTHLY

SUBSCRIPTION RATES

Yearly in U. S. and Possessions and Canada, \$3.00
Foreign Postage, \$1.00 additional. Single copies, 25 cents.

Vol. XXII

October, 1927

No. 3

Time to Act, Mr. President

RADIO—man's latest gift from the gods—is another conveyor of thought. The personal and public spoken word, the quicker printed and wired message, the moving picture are now augmented by broadcasting. Freedom of speech is its right by heritage.

No federal regulatory authority controls tongues or words, or limits the manufacture or use of printing presses, ink, paper, moving picture machines or films, telegraph poles or wires. The only governmental restriction on speech, the movies and the press are those of decency. Supervision of rates on wires gives some semblance of federal control. With broadcasting it is different. This new form is placed in the hands of a federal commission—composed of at least three inexperienced men, two of whom are young and unknown—all hand picked by the interests.

The foregoing explains to the uninitiated the reasons for the favoritism shown and the politics played in the recent allocation of wave lengths and power. Even a cursory examination of the new assignments will convince the most skeptic that there is a well defined plan for controlling broadcasting. This ambitious program has been plotted by selfish and unscrupulous men in New York who are drunk with sudden prominence and lusting for power.

If the air is to be free, the President will have to act as he did with the Federal Reserve Board before permanent licenses are granted.

Natural Monopolists, John!

Radio Digest agrees with John Shepard, III, of WNAC, Boston, regarding the broadcast of the Tunney-Dempsey fight:

"The National Broadcasting Company prevented stations on the Columbia Broadcasting System (of which station WNAC is one) from broadcasting the Tunney-Dempsey battle direct from the ringside.

"It seems to me that this is a most short-sighted policy, and one tending to build ill will rather than good will for this company and the sponsors of the fight program. The National Broadcasting Company, being controlled by corporations manufacturing and marketing Radio sets and equipment, should be interested in having the best possible programs reach the listening public.

"In the broadcasting of a world's championship fight the announcer is practically 100 per cent of the broadcast. In preventing the Columbia System from broadcasting the bout, the listeners were deprived of hearing Major J. Andrew White's description, and if they listened to the bout at all, were compelled to listen to Graham McNamee.

"With all due respect to Graham McNamee and his many fine points, I do not consider him in the class of Major White when it comes to describing a battle in the square ring, and as the officials of the National Broadcasting Company have always engaged Major White for the broadcasting of important fights, up to the time that he was no longer available because of his connection with the Columbia Broadcasting System, it would seem as if that was their opinion also.

"Each man has his ardent supporters. Both are good; in fact, excellent announcers, but it is my belief that those who are interested in the fight itself, and an accurate description of it, prefer the Major's reporting.

"The question is the National Broadcasting Company going to say in effect to the millions of listeners. 'Yes, you can hear a broadcast from the ringside, but you cannot hear Major White report it.'"

Grave stones will be guideposts for resurrection morn.

Leaving the heir: "My boy, there is a better medium of exchange than money—love."

THE READER'S VIEW

READER ASSAILS COMMISSION

I RECEIVED the surprised of a lifetime today when I read your eulogy of the federal Radio commission's "fearless action" in compelling all stations to stay on their wave via using Piezo crystals. Can it be possible that you, too, have become so gullible as to believe that the learned commission is actually interested in the welfare of the listeners-in?

As I understood the matter, these gentlemen were appointed Radio commissioners to clear up the air and end the chaos that existed. Instead of doing so, they have made a worse muddle than ever by granting exorbitant increases of power to various stations that are entirely unwarranted.

That dear friend of the B. C. L. (Prof. Goldsmith) claims that the service area of a 500-watt station is ten miles or so. Of course, all those speeches he made in various parts of the country were not intended to "soften up" the public to the idea of 50,000 watts for WEA! Oh, no!

I have never objected to the chain idea, for I feel that people in the south, west, New England, etc., are entitled to hear WEA and WJZ as well as we in the Metropolitan section. And I also think that these two stations are entitled to more power than the others. I should say about five or ten thousand watts for each, not 50,000 and 30,000, respectively. And I'll tell you why.

YOU will note that the Eveready program is sent out over 18 broadcast channels by twenty different stations, using an aggregate of 196,750 watts of power. You will also note that every one of these stations are located above 300 meters on the broadcast band. These same stations under Mr. Hoover (before the piracy began) used a total of 36,250 watts, or 160,500 watts less than they are using today. And then when you consider that 18 of the available 42 wave channels above 300 meters are sending out this program, and that there are two stations doing so on two different wave lengths, it doesn't take a great deal of intelligence to understand that it is ridiculous for WEA to insist it needs 50,000 watts, or for any of the others to claim the necessity of more than 500 or 1,000 watts at the most.

THE time has come where the B. C. L. should let this federal Radio commission know that the members were appointed to protect the interests of the listeners, and I insist that they have been guilty of gross negligence in this matter. In fact, all of their decisions have been in favor of the broadcasters—at least some broadcaster.

Here are a few things I'd like to have the commission explain:

Why was KFQB, Fort Worth, Texas, dropped from 508 meters to 222 meters?

Why was WREO, Lansing, Mich., dropped from 285.5 meters to 231 meters? This station did put on excellent programs.

Why was WCAL, Northfield, Minn., dropped from 337 meters to 236 meters?

Why was KFRU, Columbia, Mo., dropped from 500 meters to 250 meters?

Why should WOK and WMBB of Chicago be permitted to use 5,000 watts? And WJAZ, Chicago, as well? And also WMBI, as I understand have just received permission.

Why was KLDS, Independence, Mo., dropped from 441 meters to 270 meters?

Why should WHAM, Rochester, be permitted to use 5,000 watts?

Why should WBCN and WENR of Chicago be more entitled to 5,000 watts as the property of Samuel Insull and his power combine than under their former owners?

Why should WODA of Paterson, N. J., be entitled to 1,000 watts when they were one of the worst offenders at broadcasting phonograph records and were also wave jumpers?

Why was WOAI, San Antonio, dropped from 395 meters to 303 meters?

WHAT is WGN permitted 15,000 watts unless the commission is afraid of the power this great newspaper wields?

Why was WABC, Richmond, N. Y., permitted exclusive time on the 326 meter channel when the veriest novice knows that their plea to "share time" with KBOQ (which they also own) was merely a subterfuge to obtain this exclusive wave?

Why was WSM granted the 341 meter wave instead of 283 meters which they formerly had?

Why was WOC, Davenport, dropped from 384 meters to 353 meters?

Why was WDAF, Kansas City, put on the same wave with WMCA and WLWL of New York City?

Why was WBBM and WJBT granted the choice 390 meter wave?

Why should WCCO be put on the same wave with WPT and WLIT of Philadelphia?

Why should WIBO, Chicago, be advanced to the 416 meter wave?

Why should KFNF, Shenandoah, be permitted to broadcast their direct advertising talks on the choice 461 meter wave?

Why was WSB, Atlanta, taken off the 428 meter wave when we could hear them (and we greatly enjoyed hearing the "Little Colonel") and put on the 476 meter wave where we cannot hear them?

Why should WJAR, Providence, be permitted to retain their 484 meters wave which they pirated instead of being put back on 306 meters where they had been allocated by Mr. Hoover?

Why should KFCK be changed from 288 meters to 526 meters?

It is my belief that the much heralded Radio commission has fallen down on the job badly, and if I had made such a poor job of anything I had attempted as they have, I'd resign at once to permit the appointment of some one more capable of handling the situation in an efficient manner.

Radio Digest has a duty to perform in the interest of its readers, and the rest of the listening public. Will it rise to the occasion and fulfill this duty or will it, too, fall down on the job like the Radio commissioners have done?

L. S. J. CRANSE, 22 South St., Summit, N. J.

Speaking Extemporaneously



RADIO INDI-GEST

That Dumbest Feelin'

When the person who looks after the Radio
On his vacation has gone,
And just when you want to hear something
You find that something is wrong,
You open the cabinet and look inside;
Bewildered, you turn every knob in sight
And after playing around awhile
You find the darn thing won't even light.
You rush to the phone and call a service man
And tell him your tale of woe,
That the blamed thing won't work
And you just can't make it go.
And then while you're waiting for him to call
You glance around and find—
Someone had pulled the plug out of the wall.
Ain't THAT the dumbest feelin'!
That Red-Head Gal,
BOBETTE.

Pig Tails Is Pig Tales

SOME receivers have cat's whiskers, and some have pigtail coils. In making this explanation Indi takes occasion to apologize for our Mr. McDonald, who meant no insult to the readers when he said in his article on trouble shooting, "... at any rate, gently lift the outer coil of the spiral of the pigtail (if you have one) to see that ..."

Anybody knowing of any right good authority for the correct pronunciation of the various Radio names and devices will confer a favor by communicating with Mr. Quin Ryan—mikitivty, for instance. Address care WGN, Chicago Tribune Tower.

Since Wilda Church has decreed the Radio audiences must no longer be hoodwinked by fake handmade kisses, a larger interest is being shown in rehearsals.

Dear Indi: This sommer me and my portable wur out to a camp and I fell in luv (Or dear, Oh me, Oh my, Oh-h-hhh). I trid to think of a novel way to court her. Sow, aftur scratching my head fore to aft and eer to eer I hit on the skeam to tell her from WFBM when I knu she wood be lissuning. Sow I made up a poem, which I shode to the direktur, like this:

I luv u on high,
I luv u on the level—
But if I held u in my arms,
(Oh) I'd luv u like the devul!

The direktur sed they alreddy hed to mush trubil with the announsur who get that way, and besideways they were shutup for the sommer. Sow, now whattum I goin' to do (Oh)? O doant wish these WFBM burds no bad luck, but I wanta say to the Radio committers at Washington, "moar power to WOWO."

L. L. Htims, Fort Wayne, Ind.

Steeplechase Words

LOOK! LOOK! dear Indi-spensibles, one of you sent in a hint about a new game. It wasn't signed, don't know where you got the idear, but it's good. You know how we had Cross Words, Golf Words (like white to black, ape to man, etc.)—well, this is Steeplechase words, where you take a word and make puzzle sentence out of it. Suppose you have the words "seethe" and "saliniform." Then you use them this way: "We seethe the girl's knees"; or "Getting a husband's saliniform." Now here's a set of words for you to work out: Director, wattle, bitter, music, laughter. Send in your five sentences and win a prize for the cutest list. First prize, 1 Blue Jelly Bean; second prize, 1 Yellow Jelly Bean; third prize, 1 Red Jelly Bean. First come, first served. The best list will be published, if received before October 15.

INDI

ALUMINUM

Everywhere You Turn at the Radio Show

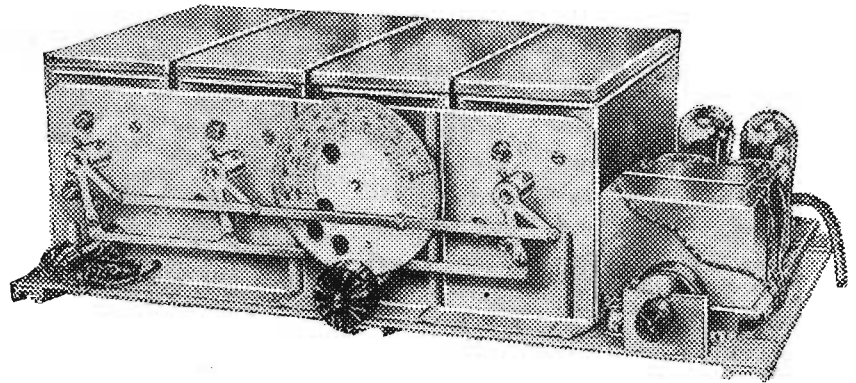
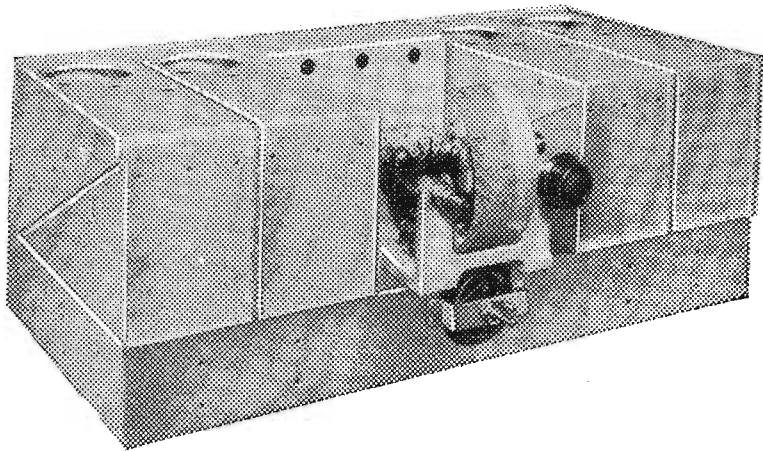

Extensive shielding was noticeable in the improved sets shown by leading manufacturers at the Radio Show in New York and will be observed again in the Chicago Show.

manufacturing policy, were favorable to Aluminum.

The fact that Aluminum for shielding is the metal found in so many of the best sets should be a guide to the layman, either in building or buying.

Aluminum is the metal used for shielding in the majority of standard sets. This indicates that the results of their experiments, which always precede a



All information on the subject of Aluminum in Radio may be had at the Chicago Radio Show, Booth C. C. 1.

ALUMINUM COMPANY OF AMERICA

2466 Oliver Building, Pittsburgh, Pa.

Offices in 18 Principal American Cities

A L U M I N U M I N E V E R Y C O M M E R C I A L F O R M



CECO

Amplifier
Type M-26

(226)

Fil. Volts.....1.5
Fil. Amp.....1.05
Plate Volts.....90-135
Not to Exceed.....180

LIST PRICE,

\$3.00



Announcing
A. C. TUBES

ALTERNATING CURRENT

using raw A. C. on the Filament or Heater and can be used in any set specifying these types. The M-26 is used in the radio and audio frequency stages and has a standard base. The N-27, of the separate heater type, is used as a detector or amplifier and has a five-prong base. Will give superior results and maximum useful life in any set designed to use A. C. Tubes of this type.

Write for Particulars

C.E. Mfg. Co., Inc., Providence, R.I., U.S.A.



CECO

Detector
Type N-27

(227)

Heater Volts.....2.5
Heater Amps.....1.75

PLATE VOLTS

As Detector.....45
As Amplifier.....90-135
Not to Exceed.....180

LIST PRICE,

\$6.00

Largest Plant in the World Making Radio Tubes Exclusively

OCTOBER BRINGS BROADCAST OF WOR

HIGH LIGHTS OF THE AIR

THE WORLD Series will be broadcast by all the stations now giving baseball scores and complete descriptions of games. Where the station is too far away to give a picture of each game, the station will keep the fan in touch with the leading events of the day.

October is the month in which football as a sport holds the public eye and the Radio ear. A list of many of the games to be broadcast may be found under the Headliners on Saturdays.

WSM has turned Monday night into a frolic. Singers of popular songs, a dance orchestra, strummers on mournful guitars, and plenty of good comedy is injected into the proceedings beginning at 8 p. m. Central time. Tom, Joe and Jack, the Minstrel Boys who have recently returned from a gorilla hunt in Radio-land, have some new antics to perform.

Fans in and around Cincinnati are feeling lost and unhappy because they cannot hear Ford and Glenn any more. However, this happy pair of Radio entertainers has merely moved to Detroit for the fall and may now be

heard at WJR. The famous "Dinner Bell" program of the team will be given as usual at noon. At 7:15 p. m. the children will have their lullaby hour. A popular song for grownups is broadcast at 10 o'clock.

A series of Sunday evening concerts given at 5 p. m. Pacific time are being given for Western fans by the Abas string quartet over KPO. These well known artists are members of the San Francisco symphony orchestra.

Those blackface comedians, the KOA Minstrels, are so popular with mountain fans that they are giving, by request, a repeat performance of their "Dark, Dark Secrets" Monday, October 14, at 8:15 p. m. Tambo, Bones and Rastus promise a hilarious time for all.

The new Columbia Broadcasting system promises new voices and new broadcasting ideas during this chain's programs which will be on the air Mondays, Wednesdays and Fridays from 9-11 p. m. Eastern time. The Sunday programs will be broadcast from 3-5 p. m. and 9-11. The stations broadcasting these programs may be found under the Headliners.



For over a year Vella Cook's rich contralto voice has been heard at WCFL, Chicago. She is a permanent member of the Voice of Labor's staff.



In constant demand for parties and unusual request programs is the Edgeworth Banjo trio below. They are shown here before the microphone of WRVA planning an unusual feature for the evening program. Southern melodies and old plantation songs when played by this trio have the flavor of the old time South.

SATURDAY, OCTOBER 1

Headliners

Eastern	Central	Mountain	Pacific
7:30 p. m.	6:30	5:30	4:30
WJR-WCX baritone.	(440.9m-680kc)	Aubrey Hartman.	
7	6	5	
WIP (508.2m-590kc)	Gargaret Gavaghan, soprano.		
WOC (352.7m-850kc)	Lela Sutcliffe, soprano;		
8:05	7:05	6:05	5:05
WTAG (516.9m-580kc)	WTAG Little symphony.		
8:15	7:15	6:15	5:15
WIP (508.2m-590kc)	Recital; Ambrose McIntyre,		
8:20	7:20	6:20	5:20
WGY (379.5m-790kc)	Gold Medal man.		
8:30	7:30	6:30	5:30
WBZ (333.1m-900kc)	Percy Ensemble Club.		
WHAS (461.3m-650kc)	Studio concert under aus-		
9	8	7	6
WDAF (370.2m-810kc)	Eddie Kuhn's Kansas City		
WIP (508.2m-590kc)	American Legion Glee Club.		
WMAQ (447.5m-670kc)	Radio photologue,		
9:01	8:01	7:01	6:01
WTAG (516.9m-580kc)	concert, Worcester Music		
9:30	8:30	7:30	6:30
KTHS (384.4m-780kc)	Lon Chassy, violinist.		
WDAF (370.2m-810kc)	Hornor Conservatory.		
WBO (533.4m-560kc)	Four Horsemen quartet.		
WMBB (252m-1190kc)	Trion orchestra; popular		
9:45	8:45	7:45	6:45
WIP (508.2m-590kc)	Tom Adams and his Musical		
10	9	8	7
WBZ (331.1m-900kc)	Bert Lowe and his Hotel		
WJR-WCX (440.9m-680kc)	Ford and Glenn.		
WMAQ (447.5m-670kc)	Popular song cycle, Pratt		
10:00	9:00	8:00	7:00
KGO (384.4m-780kc)	Wilt Gunzenodorf's Hotel		
	Whitcomb band, San Francisco.		

Football

Bradley-Illinois at Urbana, WRM (272.6m-1100kc), Iowa-Monmouth College at Iowa City, WSUI (422.3m-710kc), Minnesota-North Dakota at Minneapolis, WAMD (225.4m-1330kc), Northwestern-South Dakota at Evanston, WEBII (365.6m-820kc), WIBO (416.4m-720kc), Oklahoma-Chicago at Chicago, WMAQ (447.5m-670kc), WMBB (252m-1190kc), Santa Clara-U. S. C at Los Angeles, KFI (468.5m-642kc), Stamford-St. Mary's at Palo Alto, KPO (422.3m-710kc), Wittenberg-Ohio at Columbus, WEO (282.8m-1060kc).

Regular Saturday Features

Eastern Time Stations
KDKA Pittsburgh, Pa. (315.6m-950kc) 7:30 p. m. concert.
WBZ Springfield, Mass. (333.1m-900kc) 7:34 p. m. ensemble; 7:45, 10, orchestra.
WCAE Pittsburgh, Pa. (516.9m-580kc) 7:45 p. m. musicals; 8:30, WEAF.
WEAF New York, N. Y. (491.5m-610kc) 7:30 p. m. Week-Enders, WEEL, WRC, WGR, WCAE, WJAR, WTMJ; 8:30, Old Gold on Broadway; 11, orchestra.
WEEL Boston, Mass. (447.5m-670kc) 7:30 p. m. WEAF.
WEAF Buffalo, N. Y. (303m-990kc) 8 p. m. WEAF; 9:30, WEAF; 11:05, symphony.
WCY Schenectady, N. Y. (379.5m-790kc) 7:30 p. m. musicals; 8:30, musicals; 11, dance music.
WHK Cleveland, Ohio (265.3m-1130kc) 8 p. m. program; 11, Rubenneck man.
WHAR Atlantic City, N. J. (272.6m-1100kc) 8 p. m. Seaside hotel trio.
WIP Philadelphia, Pa. (508.2m-590kc) 7 p. m. bedtime story; 8, recital; 9, concert; 10, orchestra; 11:05, organ.
WJAX Jacksonville, Fla. (336.9m-890kc) 8:05 p. m. program.
WJR-WCX Detroit, Mich. (440.9m-680kc) 7 p. m. Pontiac will ensemble; 8, Ford and Glenn; 11:30, Pontiac Tribe.
WJZ New York, N. Y. (454.2m-660kc) 7 p. m. Hotel Astor orchestra; 8:30, Mediterranean dance band, WHAM; 10, time, WBZ; 10, Keystone duo; 10:30, orchestra.
WMAQ Buffalo, N. Y. (545.1m-550kc) 7:30 p. m. Musical; 8:30, program; 9:30, musicals.
WMCA New York, N. Y. (370.2m-810kc) 6:30 p. m. orchestra; 8, musical extravaganza; 9, boxing bouts; 11, entertainers.
WOR Newark, N. J. (422.3m-710kc) 6:15 p. m. ensemble; 9:30, orchestra; 10:55, news; 11, orchestra.
WPG Atlantic City, N. J. (672.6m-1100kc) 7:05 p. m. dinner music; 10, studio program; 11:30, dance orchestra; 12, orchestra.
WRC Washington, D. C. (468.5m-640kc) 7 p. m. Bible talk; 8:30, WEAF; 9:30-12, WEAF.
WSAI Cincinnati, Ohio (361.2m-830kc) 8:01 p. m. music; 9, orchestra; 11:30, orchestra.
WSEA Norfolk, Va. (263m-1140kc) 7 p. m. dinner concert; 8, recital.
WTAG Worcester, Mass. (516.9m-580kc) 8 p. m. orchestra; 10, orchestra.
WTAM Cleveland, Ohio (399.8m-750kc) 6 p. m. orchestra; 7, studio concert; 7:30, WEAF; 8:30, Pocahontas Indians; 9, Ev Jones and his Merry-makers.

WWNC Asheville, N. C. (296.9m-1010kc) 7 p. m. dinner concert.

Central Standard Time Stations

KFAB Lincoln, Nebr. (309.1m-970kc) 5:30-6:30 p. m. Hotel Lincoln orchestra; 8:30-9, Buick Little symphony; 9-10, Chamber of Commerce program.
KMA Shenandoah, Ia. (394.5m-760kc) 6 p. m. sacred songs, 7, trio; 8, singers.
KPRC Houston, Tex. (296.9m-1010kc) 7:30 p. m. studios concert.
KTHS Hot Springs National Park, Ark. (384.4m-780kc) 8:30 p. m. musicals; 9, dance concert.
KYW Chicago, Ill. (526m-570kc) 7-10:30 p. m. program; 10:32-10:55, Congress hotel music.
WBAP Ft. Worth, Tex. (499.7m-600kc) 7:30-8 p. m. Interdenominational Sunday school lesson; 9:30, Clyde and Florence Messengale, popular numbers; 10:30, theater program.
WBBM Chicago, Ill. (389.4m-770kc) 7 p. m. orchestra; 10, studio program; 12, jazz program.
WBCN Chicago, Ill. (288.3m-1040kc) 7 p. m. classical program.
WCCO Minneapolis-St. Paul, Minn. (405.2m-740kc) 6:15 p. m. dinner concert, Wesley Barlow's Nicolet hotel orchestra; 8, music; 10:45, dance program.
WDAF Kansas City, Mo. (370.2m-810kc) 8, program; 8:30-10, popular program; 11:45-1 a. m. Nighthawk frolic.
WEBH Chicago, Ill. (365.6m-820kc) 7:30-8:45 p. m. hotel orchestra; 8:45-10:15, music; 11-12, orchestra.
WENR Chicago, Ill. (288m-1040kc) 6 p. m. organ; 8, classical program; 9:30, popular program.
WFAA Dallas, Tex. (459.7m-600kc) 6:30-7:30 p. m. program; 8:30-9:30, players; 11-11:30, orchestra; 11:30-12:30 a. m. Palace theater feature; organ recital.
WGN Chicago, Ill. (305.9m-980kc) 6:10 p. m. Punch and Judy; 6:35, ensemble; 6:50, Old fashioned Almanack; 8:30, Saleros; 9:30, Over the Hills and Far Away; 10, Sam 'n' Henry; 10:20, music box; 10:40, musicale.
WHAS Louisville, Ky. (461.3m-650kc) 7:30 p. m. program.
WHB Kansas City, Mo. (336.9m-890kc) 7-8 p. m. organ; 8-10, concert.
WHI Chicago, Ill. (416.4m-720kc) 8 p. m. program.
WIBO Chicago, Ill. (416.4m-720kc) 6:45-7 p. m. songs; 10-1, popular program.
WJAZ Chicago, Ill. (263m-1140kc) 7 p. m. dinner concert; 9, studio.
WJJD Chicago, Ill. (365.6m-820kc) 6 p. m. symphony; 9:15-11, studio program; 12, Palmer House program.
WLAC Nashville, Tenn. (226m-1330kc) 7 p. m. children's period; 8-9, program.
WLS Chicago, Ill. (344.6m-870kc) 7:30-1 a. m. barn dance.
WLW Cincinnati, Ohio (428.3m-700kc) 7 p. m. organ; 9, Castle Farm; 9:40, Castle Farm.
WMAQ Chicago, Ill. (447.5m-670kc) 7 p. m. dance music; 8, photologue; 9, song cycle; 1, popular program.
WOC Davenport, Ia. (374.8m-800kc) 7-8 p. m. musicals.
WOW Omaha, Neb. (508.2m-590kc) 7 p. m. program; 7:30, program; 8, literary period; 9, program; 10, orchestra.
WQJ Chicago, Ill. (447.5m-670kc) 9:45 p. m. popular program.
WRR Dallas, Tex. (352.7m-850kc) 6-7 p. m. musical program; 8-9, classical program.
WSB Atlanta, Ga. (475.9m-630kc) 8 p. m. program; 10:45, concert.
WSM Nashville, Tenn. (340.7m-880kc) 8-11 p. m. barn dance.
WSMB New Orleans, La. (322.4m-930kc) 8:30-10:30 p. m. Public School of the Air program; organ solos.
WTMJ Milwaukee, Wis. (293.9m-1020kc) 7-9 p. m. WEAF; 9:05, orchestra.
Pacific Standard Time Stations
KFI Los Angeles, Calif. (468.5m-640kc) 7:30 p. m. program; 8, network; 9-10, classical program; 11-12 a. m. KFI midnight frolic.
KFOA Seattle, Wash. (447.5m-670kc) 8-9 p. m. National Broadcasting company.
KFWB Hollywood, Calif. (282m-1190kc) 6-7 p. m. Pontiac dinner hour; 8-9, program; Mona Motor Oil Company; 9-10, musicals; 10-11, program.
KGO Oakland, Calif. (384.4m-780kc) 8 p. m. National Broadcasting company; 9, concert; 10, band.
KGW Portland, Ore. (491.5m-610kc) 6-7 p. m. dinner music; 8-9, National Broadcasting company; 10-12, dance music.
KHJ Los Angeles, Calif. (405.2m-740kc) 6:30 p. m. children's hour; 8-10, varied program.
KJR Seattle, Wash. (343.6m-860kc) 8-10 p. m. studio program.
KNX Hollywood, Calif. (336.9m-890kc) 7:30 p. m. features; 10, Hotel Ambassador; 11, Saturday night frolic; 12, midnight express.
KPO San Francisco, Calif. (422.3m-710kc) 6:30 p. m. States Restaurant orchestra; 8, National Broadcasting company; 9, dance; 11, orchestra.
 Saturday, silent night for: KFDM, KGA, KLX, KOA, KOB, KOIL, WBAL, WBT, WCBZ, WCSH, WFLA, WGBF, WCHP, WHB, WHN, WHO, WICC, WJAR, WGB, WGS, WRVA, WTN, WJZ.

SUNDAY, OCTOBER 2

Headliners

Eastern	Central	Mountain	Pacific
3 p. m.	2	1	12
WOR (422.3m-710kc)	WEAN (319m-940kc)		
WNAC (352.7m-850kc)	WFBL (258.5m-1160kc)		
WMAK (545.1m-550kc)	WCAU (277.6m-1080kc)		
WJAS (270.1m-1110kc)	WADC (296.9m-1010kc)		
WAIU (282.8m-1060kc)	WKRC (333.1m-900kc)		
WGHP (319m-940kc)	WMAQ (447.5m-670kc)		
KOIL (277.6m-1080kc)	KMOX (299.8m-1000kc)		

Eastern	Central	Mountain	Pacific
3 p. m.	2	1	12
WOWO (228.9m-1310kc)	WCAO (384.4m-780kc)		
3	2	1	
WOR (422.3m-710kc)	WEAN (319m-940kc)	WNAC (352.7m-850kc)	WFBL (258.5m-1160kc)
WMAK (545.1m-550kc)	WCAU (277.6m-1080kc)	WJAS (270.1m-1110kc)	WADC (296.9m-1010kc)
WAIU (282.8m-1060kc)	WKRC (333.1m-900kc)	WMAQ (447.5m-670kc)	WGHP (319m-940kc)
WMAQ (447.5m-670kc)	KOIL (277.6m-1080kc)	KMOX (299.8m-1000kc)	WOWO (228.9m-1310kc)
WCAO (384.4m-780kc)	Columbia chain.		
7:30	6:30	5:30	4:30
WHO (535.4m-560kc)	Bankers Life Little symphony.		
8:30	7:30	6:30	5:30
KFI (468.5m-640kc)	KPO (422.3m-710kc)	KGW (491.5m-610kc)	KGO (384.4m-780kc)
9	8	7	6
WCBZ (444.6m-870kc)	Semi-chorus.		
WOR (422.3m-710kc)	WEAN (319m-940kc)	WNAC (352.7m-850kc)	WFBL (258.5m-1160kc)
WMAK (545.1m-550kc)	WCAU (277.6m-1080kc)	WJAS (270.1m-1110kc)	WADC (296.9m-1010kc)
WAIU (282.8m-1060kc)	WKRC (333.1m-900kc)	WMAQ (447.5m-670kc)	WGHP (319m-940kc)
WMAQ (447.5m-670kc)	KOIL (277.6m-1080kc)	KMOX (299.8m-1000kc)	WOWO (228.9m-1310kc)
WCAO (384.4m-780kc)	Columbia chain.		
8:30	7:30	6:30	5:30
WJZ (454.3m-660kc)	WEAM (277.6m-1080kc)		
9:30	8:30	7:30	6:30
WMBB (252m-1190kc)	Dell Lampe; Trianon Ensemble.		
WOR (422.3m-710kc)	WEAN (319m-940kc)	WNAC (352.7m-850kc)	WFBL (258.5m-1160kc)
WMAK (545.1m-550kc)	WCAU (277.6m-1080kc)	WJAS (270.1m-1110kc)	WADC (296.9m-1010kc)
WAIU (282.8m-1060kc)	WKRC (333.1m-900kc)	WMAQ (447.5m-670kc)	WGHP (319m-940kc)
WMAQ (447.5m-670kc)	KOIL (277.6m-1080kc)	KMOX (299.8m-1000kc)	WOWO (228.9m-1310kc)
WCAO (384.4m-780kc)	Columbia chain.		
10:30	9:30	8:30	7:30
KTHS (384.4m-780kc)	Clyde Foley, balladist.		
11	10	9	8
KFI (468.5m-640kc)	Pat O'Harrow and his Irish serenaders.		
WIBO (416.4m-720kc)	Mabel Day, prima donna.		
12 mid.	11	10	9
KFON (233m-1290kc)	Texas Cowboys.		
WFAA (499.7m-600kc)	La Mariquita and her Castilian orchestra.		

Regular Sunday Features

Central Time Stations

KDKA Pittsburgh, Pa. (315.6m-950kc) 2 p. m. WJZ; 7:30, concert; 8:15, WJZ; 9:15, WJZ.
WBAL Baltimore, Md. (285.5m-1050kc) 6:30-7:30 p. m.
WBZ Springfield, Mass. (333.1m-900kc) 2 p. m. WJZ; 7:15, Hotel Statler ensemble; 8:15, WJZ; 9:15, program.
WCAE Pittsburgh, Pa. (516.9m-580kc) 9:30 a. m. church; 5:30, WEAF; 6:30, dinner concert; 7:18, WEAF; 9:15, WEAF; 9:45, WEAF.
WCSH Portland, Me. (361.2m-830kc) 10:30 a. m. church; 7:30, church; 9:15, WEAF.
WEAF New York, N. Y. (491.5m-610kc) 3 p. m. service; 5:30, young artists program; 7:20, Capitol theater, WEEL, WJAR, WTAG, WRC,

DANCING Central Time

Monday
 8, Wgcp; 9, Wjar; 9:15, Wagh; 10, Kths, Wgcp, Wgr, Wnc; 10:15, Wor; 10:30, Wgcp, Whn; 11, Kgw, Koll, Wgbu, Wgcp, Wgr, Whn, Whw, Wjz; 11:45, Wdaf; 12, Knx, Kpo.
Tuesday
 10:15, Kth; 10:30, Kths, Whn; 11, Wsb; 11, Kgw, Koll, Whn, Wjz; 11:45, W; 12, Kgw, Khj, Knx, Kpo, Wdaf, Wjz; 1, Wjz.
Wednesday
 9:15, Waf; 9:30, Wbad, Who, Wjz; 10, Wbad, Wgaf, Wgbu, Wgcp, Wjz; 10:05, Wgcp; 10:30, Wbad, Whn; 11, Kmox, Koll, Kpo, Wgbb, Wgbu, Wgcp, Wgr, Whn, Wjz; 11:45, Wdaf; 12, Kwa, Knx, Kpo, Wjz, Wjz.
Thursday
 8, Wjr; 9, Wgbb, Wcel, Whn, Wjr, Wmbb, Wsal, Wtag; 9:05, Wbz, Wlp; 9:30, Wgbs, Wgy, Whn; 9:35, Wngs; 10, Kths, Whn, Wgaf, Wgcp, Whn, Wmca, Wng, Wjz; 10:30, Kths, Whn, Wgbb, Wgbu, Whn, Wjz; 11:45, Wdaf; 12, Kgo, Khj, Knx, Kpo, Wjz.
Friday
 8, Wjz; 9, Wcx, Wgbb, Wgcp, Wgcp, Wgcp, Wmbb; 9:30, Wcau, Whn; 10, Kpo, Kths, Wgbu, Wgcp, Whn, Wgr, Wjz.
Saturday
 10:45, Wls; 11, Kfwb, Kpo, Wgbb, Wfna, Who, Wjz, Wg; 11:30, Kgo, Wdaf; 11:45, Kgo, Kgw, Knx, Wjz, Wjz.
 8, Wjz; 9, Wcx, Wgbb, Wgcp, Wgcp, Wmbb; 9:30, Wcau, Whn; 10, Kpo, Kths, Wgbu, Wgcp, Whn, Wgr, Wjz.
WSAI Cincinnati, Ohio (361.2m-830kc) 7:45 p. m. chimes; 8:15, time; 8:15, WEAF; 8:45, Congress string quartet.

WORLD SERIES AND FOOTBALL GAMES



When Uncle John of KHJ entertains the children on Thursdays, he calls in June Brandon, contralto, to sing for them. She has many friends among the little folks.

In constant demand for parties and unusual request programs is the Edgeworth Banjo trio below. They are shown here before the microphone of WRVA planning an unusual feature for the evening program. Southern melodies and old plantation songs when played by this trio have the flavor of the old time South.

FARMERS' PROGRAM INDEX

Special Farm Features

Weather

Local Time

KDKA, 10 a. m., 11 p. m.
 KFJ, 8:30 p. m.
 KFNP, 7:30 a. m., 12:40 p. m.
 KFOA, 4:30 p. m.
 KFWI, 10:30 a. m.
 KGA, 6 p. m.
 KGO, 12:30 p. m., 7:03 p. m.
 KGW, 10 a. m., 7:30 p. m.
 KJR, 12 n.
 KMMJ, 9:30 a. m., 12:30 p. m.
 KOA, 11:45 a. m.
 KOIL, 11:45 a. m., 5:45 p. m.
 KOMO, 12:15 p. m., 8 p. m.
 KPO, 12 n.
 KYW, 10:55 a. m., 11:55 p. m.
 WABC, 11:55 a. m., 11 p. m.
 WBZ, 11:25 a. m., 10:30 p. m.
 WSAE, 3:40 p. m.
 WCSH, 7:10 p. m.
 WCCO, 9:45 a. m., 10 p. m.
 WDAF, 5:45 p. m.
 WDBO, 7:40 p. m.
 WEEI, 11:10 p. m.
 WFAA, 10:30 a. m., 9:30 p. m.
 WGY, 12:06 p. m.
 WHAD, 10:30 a. m., 2 p. m.
 WHO, 10 a. m.
 WIP, 1:30 p. m.
 WJZ, 2 p. m.
 WLW, 11:15 p. m.
 WOAL, 10 a. m.
 WOC, 12:30 p. m.
 WOI, 10:30 a. m.
 WOO, 11:30 a. m., 10:05 p. m.
 WOI, 10:30 a. m.
 WSM, 11:45 a. m.
 WTAG, 12:59 p. m.

Eastern	Central	Mountain	Pacific
1:30	12:30	11:30	10:30
WFAA (499.7m-600kc), Farmers' hour.			
1:35	12:35	11:35	10:35
KSAC (333.1m-900kc), Farm talks.			
1:40	12:40	11:40	10:40
KFJF (270.1m-110kc), State farm talks.			
3	2	1	12
KOMO (305.9m-980kc), Garden talk.			
6:20	5:20	4:20	3:20
WDBO (288.3m-1040kc), Farm talks.			
8:30	7:30	6:30	5:30
KOA (325.9m-920kc), Farm question box.			

Wednesday

Eastern	Central	Mountain	Pacific
11:40 a. m.	10:40	9:40	8:40
WCSH (361.2m-830kc), Farm feature.			
11	10	9	8
WHK (265.3m-1130kc), Farm flashes.			
WRVA (254.1m-1180kc), Farm flashes.			
12:45 p. m.	11:45	10:45	9:45
WHK (265.3m-1130kc), U. S. farm flashes.			
12	11	10	9
WSM (340.7m-880kc), Farm Talk.			
12	11	10	9
WHB (336.9m-890kc), Farm flashes.			
WLS (344.6m-870kc), Dinner bell program.			
1:10	12:10	11:10	10:10
WMAQ (447.5m-670kc), Prairie Farmer.			
1:15	12:15	11:15	10:15
WEO (282.8m-1060kc), Farm flashes.			
WTAW (309.1m-970kc), Farm talks.			
1:30	12:30	11:30	10:30
WFAA (499.7m-600kc), Farmers' hour.			
1:35	12:35	11:35	10:35
KSAC (333.1m-900kc), Farm talks.			
5:30	4:30	3:30	2:30
KFNF (270.1m-110kc), Poultry talks.			
7:30	6:30	5:30	4:30
WLW (428.3m-760kc), Farm Bureau federation.			
8:27	7:27	6:27	5:27
KOA (325.9m-920kc), Farm talk.			

Thursday

Eastern	Central	Mountain	Pacific
11	10	9	8
WHK (265.3m-1130kc), Farm flashes.			
12:20 p. m.	11:20	10:20	9:20
WCSH (361.2m-830kc), Farm program.			
12:45	11:45	10:45	9:45
WHK (265.3m-1130kc), U. S. farm flashes.			
12	11	10	9
WSM (340.7m-880kc), Farm talks.			
12	11	10	9
WHB (336.9m-890kc), Farm flashes.			
WLS (344.6m-870kc), Dinner bell program.			
1:15	12:15	11:15	10:15
WTAW (309.1m-970kc), Farm programs.			
1:30	12:30	11:30	10:30
WFAA (499.7m-600kc), Farmers' hour.			
1:35	12:35	11:35	10:35
KSAC (333.1m-900kc), Farm talks.			
3	2	1	12
KOMO (305.9m-980kc), Poultry talk.			
9:30	8:30	7:30	6:30
KOA (325.9m-920kc), Farm question box.			

Friday

Eastern	Central	Mountain	Pacific
12	11	10	9
WHK (265.3m-1130kc), Farm flashes.			
12:20 p. m.	11:20	10:20	9:20
WCSH (361.2m-830kc), Farm hour.			
12:45	11:45	10:45	9:45
WHK (265.3m-1130kc), U. S. farm flashes.			
12	11	10	9
WSM (340.7m-880kc), Farm hour.			
12	11	10	9
KTHS (319m-940kc), Farm talks.			
WEO (282.8m-1060kc), Farm hour.			
WLS (344.6m-870kc), Dinner bell program.			
1:10	12:10	11:10	10:10
WMAQ (447.5m-670kc), Prairie Farmer.			
1:15	12:15	11:15	10:15
WTAW (309.1m-970kc), Farm program.			
1:30	12:30	11:30	10:30
WFAA (499.7m-600kc), Farmers' hour.			
1:35	12:35	11:35	10:35
KSAC (333.1m-900kc), Farm 3:30.			
5:30	4:30	3:30	2:30
KFNF (270.1m-110kc), Poultry talks.			
6	5	4	3
WTIC (535.4m-560kc), Agri. talks.			
9	8	7	6
KOA (325.9m-920kc), Aggie Kickoffs.			
9:05	8:05	7:05	6:05
WOS (230.6m-1300kc), Missouri State Board of Agriculture.			

Monday

Eastern	Central	Mountain	Pacific
9 a. m.	8	7	6
KMMJ (379.5m-790kc), Poultry talks.			
11	10	9	8
WHK (265.3m-1130kc), Farm flashes.			
12	11	10	9
WHB (336.9m-890kc), Farm flashes.			
WKAR (230.6m-1300kc), Farm talks.			
1:10	12:10	11:10	10:10
WMAQ (447.5m-670kc), Prairie Farmer.			
1:15	12:15	11:15	10:15
WTAW (309.1m-970kc), Farm talks.			
1:20	12:20	11:20	10:20
WGBF (236m-1270kc)			
WEO (282.8m-1060kc), Timely hints to farmers.			
1:30	12:30	11:30	10:30
WFAA (499.7m-600kc), Farmers' hour.			
1:35	12:35	11:35	10:35
KSAC (333.1m-900kc), Farm talks.			
6:20	5:20	4:20	3:20
WDBO (288.3m-1040kc), Farm flashes.			
8	7	6	5
KSAC (333.1m-900kc), Farm courses.			
8:30	7:30	6:30	5:30
WHB (336.9m-890kc), Poultry talk.			
9:30	8:30	7:30	6:30
KOB (394.5m-760kc)			

Tuesday

Eastern	Central	Mountain	Pacific
9 a. m.	8	7	6
KMMJ (379.5m-790kc), Poultry talks.			
11:20	10:20	9:20	8:20
WCSH (361.2m-830kc), Farm features.			
11:35	10:35	9:35	8:35
WHK (265.3m-1130kc), Farm flashes.			
11:45	10:45	9:45	8:45
WSM (340.7m-880kc), Farm talk.			
12	11	10	9
WCCO (405.2m-740kc), Farm hour.			
12:45 p. m.	11:45	10:45	9:45
WHB (336.9m-890kc), Farm flashes.			
1	12	11	10
WLS (344.6m-870kc), Dinner bell program.			

WHO Des Moines, Iowa (535.4m-560kc) 11 a. m. services; 6:30, symphony; 7:30-8:15, trio.
 WHT Chicago, Ill. (416.4m-720kc) 10-2:30 p. m., 7-10.
 WIBO Chicago, Ill. (416.4m-720kc) 8:45 a. m. 2:30-3:30 p. m., 6-8 p. m., 10-1 p. m.
 WJAZ Chicago, Ill. (263m-1140kc) 7-9 p. m. studio program.
 WJJD Chicago, Ill. (365.6m-820kc) 9 p. m. opera company.
 WLAC Nashville, Tenn. (226m-1330kc) 9:15 p. m. sacred music.
 WLIB Chicago, Ill. (305.9m-980kc) 5-5:30 p. m. musicale; 5:30, songs; 5:50, songs, Tommy Coates; 6, string quintet.
 WLS Chicago, Ill. (344.6m-870kc) 10:45 a. m. U of C. church service; 12:15 p. m. organ concert; 1:30, chapel service; 7, WLS Little Brown church.
 WMAQ Chicago, Ill. (447.5m-670kc) 7 p. m. Reverie hour; 8, Columbia chain.
 WOC Davenport, Ia. (374.8m-800kc) 1 p. m. old folks; 6:30, service; 8:15, WEA.
 WOW Omaha, Neb. (508.2m-590kc) 9 a. m. services; 1:30 p. m. Father Flanagan's boys' home period; 2:30, old time songs for shut-ins; 9, chapel service.
 WSB Atlanta, Ga. (475.9m-630kc) 5 p. m. vesper; 6:20, WEA; 8:15, WEA.
 WSM Nashville, Tenn. (340.7m-880kc) 6:20 p. m. WEA; 7:45, service.

Mountain Standard Time Stations

KOA Denver, Colo. (325.9m-920kc) 11 a. m. church service; 5:30, organ; 7:45, service.

Pacific Standard Time Stations

KFI Los Angeles, Calif. (468.5m-640kc) 7-8 p. m. organ; 8-9, classic hour; 9-10, orange network; 10-11, Packard Six dance orchestra.
 KGO Oakland, Calif. (384.4m-780kc) 11 a. m. service; 6:30-7:30, little symphony; 7:35, service; 9-10, orange network.
 KGW Portland, Ore. (491.5m-610kc) 11 a. m. church; 7:30-9 p. m. church; 9-10, symphony orchestra; 10-11, symphony.
 KHJ Los Angeles, Calif. (405.2m-740kc) 7-8 p. m. service, First M. E. church; 8-10, program.
 KJR Seattle, Wash. (442.3m-710kc) 11 a. m. service; 6 p. m., dinner concert; 7:45, organ; 8, service.
 KNX Hollywood, Calif. (336.9m-890kc) 6:30 p. m. service; 9, features.
 KPO San Francisco, Calif. (422.3m-710kc) 6 p. m. States Restaurant orchestra; 6:35, Palace hotel concert orchestra; 8:35-10, Rudy Seiger's Fairmont hotel concert orchestra.

Sunday, silent night for: KSPD, KLX, KMA, KOB, WDAF, WFLA, WSMB, WRVA, WTAG, WTIC.

MONDAY, OCTOBER 3

Headliners

Eastern	Central	Mountain	Pacific
7 p. m.	6	5	4
KMA (394.5m-790kc) Ruby trio; Hugo Heyn, marimba and vibraphone.			
7:28	6:28	5:28	4:28
WGJ (379.5m-790kc) "Footnotes" T. Arthur Cohen.			
7:30	6:30	5:30	4:30
WJZ (454.3m-660kc), KDKA (315.9m-950kc), WBZ (333.1m-900kc), KYAW (526m-570kc), WRC (468.5m-640kc), WTAS (461.3m-650kc), WSB (475.9m-630kc), WSM (340.7m-880kc), WBAL (285.5m-1050kc), WIR (440.9m-680kc).			

DANCING

Central Time

Monday
 8: Wgpc, 9, Wjar, Wor; 9:15, Wahz; 10, Kths, Wgpc, Wgr, Wnyc, Wpc; 10:15, Wor; 10:30, Wgpc, Whn; 11, Kgw, Koll, Wgpc, Wgr, Whn, Who, Wjaz; 11:45, Wdaf; 12, Knc, Kpo.
Tuesday
 10:15, Waf; 10:30, Kths, Whn; 11, Wsh; 11, Kgw, Koll, Whn, Wjaz; 11:45, W, 12, Kgw, Khj, Knx, Kpo, Wdaf, Wjaz; 1, Wjd.
Wednesday
 9:15, Waf; 9:30, Whad, Who, Wjr, Wwb, Wsal, Wuar; 9:05, Wbz, Wip; 9:30, Wgbs, Wgy, Whn; 9:35, Wnyc; 10, Kths, Wbmb, Wwf; 10, Kths, Whn, Wmca, Wpg, Wqj; 10:30, Kths, Whn, Webh, Wgpc, Wgr, Whn, Wjaz; 11:45, Wdaf; 12, Kgo, Khj, Knx, Kpo, Wjaz, Wjdd.
Thursday
 8, Wjr; 9, Webh, Weel, Whn, Wjr, Wmbb, Wsal, Wuar; 9:05, Wbz, Wip; 9:30, Wgbs, Wgy, Whn; 9:35, Wnyc; 10, Kths, Wbmb, Wwf; 10, Kths, Whn, Wmca, Wpg, Wqj; 10:30, Kths, Whn, Webh, Wgpc, Wgr, Whn, Wjaz; 11:45, Wdaf; 12, Kgo, Khj, Knx, Kpo, Wjaz, Wjdd.
Friday
 8, Wjr; 9, Wex, Webh, Weel, Wgpc, Wgr, Wnyc, Wwb; 9:30, Wcau, Whn; 10, Kpo, Kths, Wgpc, Wgpc, Whn, Wgr, Wqj.
Saturday
 10:45, Wls; 11, Kfwb,

WSEA Norfolk, Va. (263m-1140kc) 8:30, variety concert.
 WTAM Cleveland, Ohio (399.8m-750kc) 11 a. m. service; 3 p. m., musicale; 6, orchestra; 7, Park theater program; 8, service; 9, Evenson; 10, orchestra.
 WTIC Hartford, Conn. (535.4m-560kc) 4:30 p. m. Howard Radio hour; 5:30, ensemble; 6:30, Melodies for Folks at Home.
 WJJD Detroit, Mich. (352.7m-850kc) 10 a. m. services; 7:20, WEA; 9:15, WEA.

Central Time Stations

KFAB Lincoln, Neb. (309.1m-970kc) 11 a. m. service; 9 p. m., symphony.
 KLDJ Independence, Mo. (270.1m-1110kc) 8:30 a. m. Bible study; 11, studio service; 2 p. m. KLDJ string quartet; 3, Radio church; 6:30, vespers, sermon; 9:15, services, choir.
 KPRC Houston, Tex. (296.9m-1010kc) 7:30 p. m. services; 9:30, concert.
 KSD St. Louis, Mo. (545.1m-550kc) 6:20 p. m. WEA; 8:15, WEA.
 KTHS Hot Springs, National Park, Ark. (384.4m-780kc) 11 a. m. services; 8:30-9:30, Music Lovers' hour, soloists; 9:30, organ concert.
 KYW Chicago, Ill. (526m-570kc) 2 p. m. WJZ; 5:30, Rev. C. J. Pernin; 7:15-8:15, WJZ.
 WBAF Ft. Worth, Tex. (499.7m-600kc) 11 a. m. services; 12:30-1:30 p. m. Kiddies' hour; 9:30-11, sacred concert.
 WCBD Zion, Ill. (344.6m-870kc) 8 p. m. trios, mixed quartet, Zion choir.
 WCCO Minneapolis-St. Paul, Minn. (405.2m-740kc) 9:45 a. m. services; 10:50, services; 4:10 p. m. House of Hope Presbyterian church; 6, Second Church of Christ, Scientist; 8:15, WEA.
 WCOA Pensacola, Fla. (249.9m-1200kc) 11 a. m. service; 7:45, service.
 WDAF Kansas City, Mo. (370.2m-810kc) 4:30 p. m. WEA; 7:15, WEA; 8:15, WEA.
 WDDO Chattanooga, Tenn. (245.8m-1220kc) 11 a. m. service; 5, Bible forum; 7:30, service; 9:30, concert.
 WEBH Chicago, Ill. (365.6m-820kc) 10:30 a. m. Seventh Church of Christ, Scientist; 6-7 p. m. organ; 7-9, Edgewater Beach hotel orchestra.
 WENR Chicago, Ill. (288.3m-1040kc) 6-7 p. m. music; 9:30-11, classical program.
 WFAA Dallas, Tex. (499.7m-600kc) 2-3 p. m. Farmers' hour, musical; 6-7, Bible class; 8:15, WEA; 11-12, La Marquita and her Castilians.
 WGN Chicago, Ill. (305.9m-980kc) 6:10 p. m. Punch and Judy; 6:45, string quintet; 7, Million sing; 7:20, old fashioned almanack; 7:50, Blackstone string

WCAE Pittsburgh, Pa. (516.9m-580kc) 6 p. m. concert; 8, song recital; 9, orchestra; 10 grand
 WCSH Portland, Me. (361.2m-830kc) 7:30 p. m. feature; 8:30, WEA; 9:30, WEA.
 WFAF New York, N. Y. (491.5m-610kc) 7:30 Parnassus trio; WSAI; 8:30, time; 8:30, A. Synes, WEEI, WJAR, WLIT, WRC, WCAE, WYAM, WGN, WSAI, WDAF, WTIC, WOC, WWTJ; 9:30, opera, WJAR, WRC, WCSH, WCAE, WTAM, WDAF; 11, orchestra, WRC, WTIC.
 WEEI Boston, Mass. (447.5m-670kc) 8 p. minstrels; 8:30, WEA; 10, cruising the air
 WFLA Clearwater, Fla. (365.6m-820kc) 8:30 studio musicale; 9:45, Radio Ramblers.
 WGBS New York, N. Y. (348.6m-860kc) 6:30 program.
 WGHF Detroit, Mich. (319m-940kc) 6:50 p. n. chesira; 8, Columbia chain.
 WGR Buffalo, N. Y. (302.8m-990kc) 8-8:30 Hawaiian ensemble; 9, WEA; 11:05, orches
 WHAZ Troy, N. Y. (379.5

WTAG Worcester, Mass. (516.9m-580kc) 8 p. m. program.
 WTAM Cleveland, Ohio (399.8m-750kc) 6 p. m. orchestra; 7, organ; 9, WEAF; 10, studio program; 11:30, organ.
 WTIC Hartford, Conn. (535.4m-560kc) 6 p. m. program; 7, New Departure orchestra; 7:30, WEAF; 8:30, WEAF; 10:30, orchestra.
 WWJ Detroit, Mich. (352.7m-850kc) 5 p. m. dinner concert; 8, WEAF; 10, WEAF.
 WWCN Asheville, N. C. (296.9m-1010kc) 7 p. m. dinner music; 8:45, entertainers; 10, theater program.

Central Time Stations
 KFAB Lincoln, Neb. (309.1m-970kc) 5:30-6:30 p. m. Hotel Lincoln orchestra; 8:30-10:30, orchestra.
 KMA Shenandoah, Iowa (394.5m-760kc) 6 p. m. trio; 7, music; 8, Dixie girls.
 KPRC Houston, Texas (296.9m-1010kc) 7:30-9:30 p. m. studio concert.
 KSD St. Louis, Mo. (545.1m-550kc) 9:30-10:30 p. m. music; 11, theater.
 KSO Clarinda, Ia. (227.1m-1320kc) 7:30 p. m. orchestra.
 KTHS Hot Springs National Park, Ark. (384.4m-780kc) 8:30 p. m. feature program.
 WBAP Ft. Worth, Tex. (499.7m-600kc) 7:30-8:30 p. m. program; 9:30-10:30, band; 10:15-11, musical play; 11, theater.
 WCCO Minneapolis-St. Paul, Minn. (405.2m-740kc) 7 p. m. dinner concert.
 WCOA Pensacola, Fla. (249.9m-1200kc) 8 p. m. program.
 WDAF Kansas City, Mo. (370.2m-810kc) 6 p. m. school of the air; 7:30-9:30 p. m., WEAF; 11:45-1, Nighthawk frolic.
 WDOD Chattanooga, Tenn. (245.8m-1220kc) 7-8 p. m. dinner hour; 9, studio program; 10, popular music.
 WFAA Dallas, Tex. (499.7m-600kc) 6:30-7:30 p. m. feature program; 8:30-9:30, feature.
 WFB Kansas City, Mo. (336.9m-890kc) 7-8 p. m. musical; 8:9.

WHO Des Moines, Iowa (535.4m-560kc) 6:30 p. m. orchestra; 9:30, dance orchestra; 11, organ.
 WOC Davenport, Ia. (374.8m-800kc) 7:30 p. m. time; 7:30, WEAF; 8:30, organ.
 WOW Omaha, Neb. (508.2m-590kc) 6:50 p. m. musical; 8:30, orchestra.
 WSB Atlanta, Ga. (475.9m-630kc) 6:30 p. m. WJZ; 8, farm program; 10:45, artists.
 WSM Nashville, Tenn. (340.7m-880kc) 6:30 p. m. WJZ; 8, music.
 WSMB New Orleans, La. (322.4m-930kc) 8:30-10:30 p. m. Sunday South synagogues, theater orchestras, Billy Broussard, Louis Boyer, popular songsters.
 WTMJ Milwaukee, Wis. (293.9m-1020kc) 6:30 p. m. WJZ; 8, WEAF; 9, WEAF; 10:30, program.

Mountain Standard Time Stations
 KOA Denver, Colo. (325.9m-920kc) 8 p. m. Scheuerma's Colorado orchestra; 8:15, studio program.

Pacific Standard Time Stations
 KFI Los Angeles, Calif. (465.5m-640kc) 7-8 p. m. music; 8-9, orange network; 9-10, program, KPO; 10, program.
 KFOA Seattle, Wash. (447.5m-670kc) 7:15 p. m. news; 8, orange chain.
 KFRC San Francisco, Calif. (454m-660kc) 6:30 p. m. Cecilia; 8, Jamboree; 11, frolic.
 KFWB Hollywood, Calif. (361.2m-830kc) 6-7 p. m. dinner hour; 8-9, program; 9-10, program; 10-11, frolic.
 KGO Oakland, Calif. (384.4m-780kc) 6-6:55 p. m. Stanislas Bem's Little symphony; 8-9, orange network; 9, book chat.
 KGW Portland, Ore. (491.5m-610kc) 8, National Broadcasting company; 9-10, concert.
 KJR Seattle, Wash. (348.6m-860kc) 6:30 p. m. dinner hour; 7-10, studio program.
 KLX Oakland, Calif. (508.2m-590kc) 8-9 p. m. studio program; 9-10, Lake Merritt Ducks.
 KMX Hollywood, Calif. (336.3m-890kc) 7:30 p. m. playlet; 8, program; 9, feature; 10, feature; 11, frolic.
 KPO San Francisco, Calif. (422.3m-710kc) 6:30-7 p. m. States Restaurant orchestra; 7-7:30, Rudy Seizer's Fairmont hotel concert orchestra; 8-9, orange chain; 9-10, studio program; 10-11, program.

Monday, silent night for: KFDM, KHJ, KLDS, KYW, WBBM, WBCN, WCBD, WCFE, WEBB, WENR, WFI, WGBS, WGN, WHT, WIBO, WIP, WJAZ, WJLD, WLJB, WLS, WMAQ, WMBB, WOAL, WOK, WORD, WQJ, WSAI.

TUESDAY, OCTOBER 4
Headliners

Eastern	Central	Mountain	Pacific
7:30 p.m.	6:30	5:30	4:30
WCCO (379.5m-790kc) "F and R Family,"	WJZ (545.3m-660kc), WBZ (333.1m-900kc), KDKA (315.9m-950kc), KYW (526m-570kc), Stromberg-Carlson hour.	WIP (508.2m-590kc) Hugh McLaughlin, baritone.	WJZ (545.3m-660kc), WBZ (333.1m-900kc), KDKA (315.9m-950kc), KYW (526m-570kc), Stromberg-Carlson hour.
7:45	6:45	5:45	4:45
WGY (379.5m-790kc) Ollie Yettrui, pianist.	WIP (508.2m-590kc) Contralto solos by Dorothy Royal King.	WLS (344.6m-870kc) Don Malin, "Personalities in Music."	WBS (475.9m-630kc) Jolly Buckeye Bakers.
8	7:15	6:15	5:15
WIP (508.2m-590kc) Recital; Nelson A. Chesnutt, tenor.	KMA (394.5m-760kc) Dixie Girls; jubilee singers.	WCB (344.6m-870kc) Eleanor and Esther Harwood, songs.	WGB (236.1m-1270kc) Hartmetz Banjo Boys.
8:15	7:15	6:15	5:15
WIP (508.2m-590kc) Nat Lanin and his Devon Park Hotel orchestra.	KFI (468.5m-640kc) Eva Olivotti, soprano.	WBBM (389.4m-770kc) Uncle Zorn; Floyd Falch.	WHO (535.4m-560kc) Capital Theatre artists.
8:30	7:30	6:30	5:30
WFAA (499.7m-600kc) Dallas musicians, directed by Dr. G. Hayden Jones.	WMBB (252m-1190kc) Vin Lindhe; Hugh Aspinwall; popular program.	KFI (468.5m-640kc) Vlado Kolitsch, violinist.	WIBO (416.4m-720kc), Edgewater Glee Club.
8:45	7:45	6:45	5:45
KTHS (384.4m-780kc) Mrs. Boyd Goodwin, soprano.	KGO (384.4m-780kc), KFI (468.5m-640kc), KPO (422.3m-710kc), KGW (491.5m-610kc), KOMO (305.9m-980kc) Eveready hour.	WIBO (416.4m-720kc), Edgewater Glee Club.	KGO (384.4m-780kc), KFI (468.5m-640kc), KPO (422.3m-710kc), KGW (491.5m-610kc), KOMO (305.9m-980kc) Vagabonds in New Orleans.
9	8	7	6
WIP (508.2m-590kc) Recital; Nelson A. Chesnutt, tenor.	WFAA (499.7m-600kc) Dallas musicians, directed by Dr. G. Hayden Jones.	WMBB (252m-1190kc) Vin Lindhe; Hugh Aspinwall; popular program.	KFI (468.5m-640kc) Vlado Kolitsch, violinist.
9:15	8:15	7:15	6:15
WIP (508.2m-590kc) Nat Lanin and his Devon Park Hotel orchestra.	KFI (468.5m-640kc) Vlado Kolitsch, violinist.	WIBO (416.4m-720kc), Edgewater Glee Club.	KGO (384.4m-780kc), KFI (468.5m-640kc), KPO (422.3m-710kc), KGW (491.5m-610kc), KOMO (305.9m-980kc) Eveready hour.
9:30	8:30	7:30	6:30
WFAA (499.7m-600kc) Dallas musicians, directed by Dr. G. Hayden Jones.	WMBB (252m-1190kc) Vin Lindhe; Hugh Aspinwall; popular program.	KFI (468.5m-640kc) Vlado Kolitsch, violinist.	WIBO (416.4m-720kc), Edgewater Glee Club.
9:45	8:45	7:45	6:45
KTHS (384.4m-780kc) Mrs. Boyd Goodwin, soprano.	KGO (384.4m-780kc), KFI (468.5m-640kc), KPO (422.3m-710kc), KGW (491.5m-610kc), KOMO (305.9m-980kc) Eveready hour.	WIBO (416.4m-720kc), Edgewater Glee Club.	KGO (384.4m-780kc), KFI (468.5m-640kc), KPO (422.3m-710kc), KGW (491.5m-610kc), KOMO (305.9m-980kc) Vagabonds in New Orleans.
10	9	8	7
WIP (508.2m-590kc) Nat Lanin and his Devon Park Hotel orchestra.	KFI (468.5m-640kc) Vlado Kolitsch, violinist.	WIBO (416.4m-720kc), Edgewater Glee Club.	KGO (384.4m-780kc), KFI (468.5m-640kc), KPO (422.3m-710kc), KGW (491.5m-610kc), KOMO (305.9m-980kc) Eveready hour.
10:15	9:15	8:15	7:15
WFAA (499.7m-600kc) Dallas musicians, directed by Dr. G. Hayden Jones.	WMBB (252m-1190kc) Vin Lindhe; Hugh Aspinwall; popular program.	KFI (468.5m-640kc) Vlado Kolitsch, violinist.	WIBO (416.4m-720kc), Edgewater Glee Club.
10:30	9:30	8:30	7:30
WFAA (499.7m-600kc) Dallas musicians, directed by Dr. G. Hayden Jones.	WMBB (252m-1190kc) Vin Lindhe; Hugh Aspinwall; popular program.	KFI (468.5m-640kc) Vlado Kolitsch, violinist.	WIBO (416.4m-720kc), Edgewater Glee Club.
10:45	9:45	8:45	7:45
KTHS (384.4m-780kc) Mrs. Boyd Goodwin, soprano.	KGO (384.4m-780kc), KFI (468.5m-640kc), KPO (422.3m-710kc), KGW (491.5m-610kc), KOMO (305.9m-980kc) Eveready hour.	WIBO (416.4m-720kc), Edgewater Glee Club.	KGO (384.4m-780kc), KFI (468.5m-640kc), KPO (422.3m-710kc), KGW (491.5m-610kc), KOMO (305.9m-980kc) Vagabonds in New Orleans.
11	10	9	8
WIP (508.2m-590kc) Nat Lanin and his Devon Park Hotel orchestra.	KFI (468.5m-640kc) Vlado Kolitsch, violinist.	WIBO (416.4m-720kc), Edgewater Glee Club.	KGO (384.4m-780kc), KFI (468.5m-640kc), KPO (422.3m-710kc), KGW (491.5m-610kc), KOMO (305.9m-980kc) Eveready hour.
11:15	10:15	9:15	8:15
WFAA (499.7m-600kc) Dallas musicians, directed by Dr. G. Hayden Jones.	WMBB (252m-1190kc) Vin Lindhe; Hugh Aspinwall; popular program.	KFI (468.5m-640kc) Vlado Kolitsch, violinist.	WIBO (416.4m-720kc), Edgewater Glee Club.
11:30	10:30	9:30	8:30
WFAA (499.7m-600kc) Dallas musicians, directed by Dr. G. Hayden Jones.	WMBB (252m-1190kc) Vin Lindhe; Hugh Aspinwall; popular program.	KFI (468.5m-640kc) Vlado Kolitsch, violinist.	WIBO (416.4m-720kc), Edgewater Glee Club.
11:45	10:45	9:45	8:45
KTHS (384.4m-780kc) Mrs. Boyd Goodwin, soprano.	KGO (384.4m-780kc), KFI (468.5m-640kc), KPO (422.3m-710kc), KGW (491.5m-610kc), KOMO (305.9m-980kc) Eveready hour.	WIBO (416.4m-720kc), Edgewater Glee Club.	KGO (384.4m-780kc), KFI (468.5m-640kc), KPO (422.3m-710kc), KGW (491.5m-610kc), KOMO (305.9m-980kc) Vagabonds in New Orleans.
12	11	10	9
WIP (508.2m-590kc) Nat Lanin and his Devon Park Hotel orchestra.	KFI (468.5m-640kc) Vlado Kolitsch, violinist.	WIBO (416.4m-720kc), Edgewater Glee Club.	KGO (384.4m-780kc), KFI (468.5m-640kc), KPO (422.3m-710kc), KGW (491.5m-610kc), KOMO (305.9m-980kc) Eveready hour.
12:15	11:15	10:15	9:15
WFAA (499.7m-600kc) Dallas musicians, directed by Dr. G. Hayden Jones.	WMBB (252m-1190kc) Vin Lindhe; Hugh Aspinwall; popular program.	KFI (468.5m-640kc) Vlado Kolitsch, violinist.	WIBO (416.4m-720kc), Edgewater Glee Club.
12:30	11:30	10:30	9:30
WFAA (499.7m-600kc) Dallas musicians, directed by Dr. G. Hayden Jones.	WMBB (252m-1190kc) Vin Lindhe; Hugh Aspinwall; popular program.	KFI (468.5m-640kc) Vlado Kolitsch, violinist.	WIBO (416.4m-720kc), Edgewater Glee Club.
12:45	11:45	10:45	9:45
KTHS (384.4m-780kc) Mrs. Boyd Goodwin, soprano.	KGO (384.4m-780kc), KFI (468.5m-640kc), KPO (422.3m-710kc), KGW (491.5m-610kc), KOMO (305.9m-980kc) Eveready hour.	WIBO (416.4m-720kc), Edgewater Glee Club.	KGO (384.4m-780kc), KFI (468.5m-640kc), KPO (422.3m-710kc), KGW (491.5m-610kc), KOMO (305.9m-980kc) Vagabonds in New Orleans.

Regular Tuesday Features
Eastern Time Stations

KDKA Pittsburgh, Pa. (315.6m-950kc) 7:30-11 p. m. WJZ; 11:35, Grand theater.
 KYW Chicago, Ill. (526m-570kc) 7-9 p. m. WJZ; 9, classical; 10:30-11:55, program.
 WBAL, Baltimore, Md. (285.5m-1050kc) 6:30-7:30 p. m., dinner music; 7:30, quartet; 8, WJZ; 9, WJZ.
 WBZ Springfield, Mass. (333.1m-900kc) 7:03, orchestra; 7:30, ensemble; 8, WJZ; 9, WJZ; 10, musical; 10:30, dance music.
 WCAE Pittsburgh, Pa. (516.9m-560kc) 6 p. m. dinner concert; 8, musical; 9, WEAF; 12, dance music.
 WCHS Portland, Me. (361.2m-830kc) 8 p. m. Strand theater; 9, WEAF; 12, Lions Club.
 WEAF New York, N. Y. (491.5m-610kc) 9, Eveready hour; WEAF, WJZ, WGR, WFI, WRC, WCAE, WCM, WJW, WSAI, WSO, WSP, WOC, WCCO, WGY, WHAS, WSM, WSB, WMC, WDAF, 10, Cavalcade; WGR, WFI, WRC, WCHS, WCAE, WTAM, WWJ, WGY, WTMJ, WHAS, WDAF, WSAI, WTIC; 11, orchestra, WRC, WWJ, WFI.
 WEEL Boston, Mass. (447.5m-670kc) 7:30 p. m. musical; 9, WEAF; 10, cruising the air.
 WFI Philadelphia, Pa. (405.2m-740kc) 6:30 p. m. orchestra; 7:30, WEAF.
 WFLA Clearwater, Fla. (365.6m-820kc) 8:30 p. m. studio program; 9:45, Radio Ramblers.

WGHP Detroit, Mich. (319m-940kc) 8-10 p. m., musical.
 WGR Buffalo, N. Y. (302.8m-990kc) 6:30 p. m. orchestra; 7:45, science news; 8-11, WEAF.
 WGY Schenectady, N. Y. (379.5m-790kc) 7:45 p. m. musical; 8, Beech-Nut program; 9, WEAF; 10, WEAF.
 WHAR Atlantic City, N. J. (272.6m-1100kc) 7:45 p. m. book talk; 8-9, evening concert.
 WHK Cleveland, O. (265.3m-130kc) 6:30 p. m. program; 9, musical; 10, orchestra.
 WIP Philadelphia, Pa. (508.2m-590kc) 8 p. m. recital; 10, weekly movie; 10:30, orchestra.
 WJAX Jacksonville, Fla. (336.9m-890kc) 8 p. m., Just Florida Folks; 9, recital; 9:30, dance music; 10, dance music.
 WJR-WCX Detroit, Mich. (440.9m-680kc) 7 p. m. WJZ; 8, WJZ; 9, Manuel Girls; 9:30, Sandy and Cal; 9:40, Breeze Blowers; 10, Red Apple Club.
 WJZ New York, N. Y. (454.2m-660kc) 7 p. m. dog talk; 7:15, orchestra; 7:30, Cook's travelog; 8, Stromberg-Carlson hour, WBZ, KDKA, KYW, WJR, WHAM, WBAL; 9, Continentals, WBZ, KDKA, KYW, WBAL, WJR; 10, time, WBZ, KDKA, KYW, WBAL, WJR; 10, artists; 10:30, orchestra.
 WKRC Cincinnati, O. (333.1m-900kc) 6 p. m. organ; 9, dance program; 11, entertainers.
 WLW Cincinnati, Ohio (428.3m-700kc) 7:30 p. m. organ; 9, Formica concert; 10:35, dance music.
 WMAK Buffalo, N. Y. (545.1m-550kc) 6:15 p. m. movie club; 8, theater program; 10, program.
 WMCA New York, N. Y. (370.2m-810kc) 6:25 p. m. baseball; 6:30, orchestra; 10, Italian hour of song; 11, Hotel McAlpin orchestra.

WOR New York, N. Y. (422.3m-710kc) 6:15 p. m. children's hour; 6:30-11:30, program; 11:30, news; 11:35, dance orchestra.
 WPC Atlantic City, N. J. (272.6m-1100kc) 7:10 p. m. organ; 9:35, concert; 10:30, Marcele duo; 11, dance orchestra; 12, organ.
 WRC Washington, D. C. (468.5m-640kc) 6-12 mid. N. B. C.
 WSAI Cincinnati, Ohio (361.2m-830kc) 7 p. m. orchestra; 8, WEAF; 10, program.
 WSEA Norfolk, Va. (263m-1140kc) 7 p. m. dinner concert; 8:30, musical; 10, dance music.
 WTAG Worcester, Mass. (516.9m-580kc) 8:05 p. m. studio program.
 WTAM Cleveland, Ohio (399.8m-750kc) 6 p. m. State theater vaudeville program; 7, orchestra; 8, WEAF; 9, program; 9:30, WEAF; 10, Neapolitans; 11, orchestra.
 WTIC Hartford, Conn. (535.4m-560kc) 6:30 p. m. Anvileers; 7:30, WEAF; 9:30, Harmony Bells; 10:30, orchestra.
 WWJ Detroit, Mich. (352.7m-850kc) 6 p. m. dinner concert; 8, WEAF.
 WWCN Asheville, N. C. (296.9m-1010kc) 7 p. m. dinner music.

Central Time Stations
 KMA Shenandoah, Ia. (394.5m-760kc) 6 p. m. talk; 7, Twins; 8, Dixie Girls.
 KPRC Houston, Texas (296.9m-1010kc) 7:30-9:30 p. m. studio concert.
 KSL St. Louis, Mo. (545.1m-550kc) 7-9 p. m. musical; 8, WEAF.
 KTHS Hot Springs National Park, Ark. (384.4m-780kc) 8 p. m. program.

KYW Chicago, Ill. (526m-570kc) 6:32-7 p. m. dinner program; 7, WJZ; 8, WJZ; 9-10:55, musical.
 WBAP Ft. Worth, Tex. (499.7m-600kc) 7:30-8:30 p. m. musical; 9:30-11, program.
 WBBM Chicago, Ill. (389.4m-770kc) 7-10 p. m. program; 10, minstrel.
 WBCN Chicago, Ill. (288.3m-1040kc) 7 p. m. popular program.
 WCBD Zion City, Ill. (344.6m-870kc) 8 p. m. chorus, celestial bells.
 WCCO Minneapolis-St. Paul, Minn. (405.2m-740kc) 7 p. m. WEAF; 8:30, musical; 9:30, musical program.
 WDAF Kansas City, Mo. (370.2m-810kc) 7:30, WEAF; 9, program; 11:45-1, Nighthawk frolic.
 WDOD Chattanooga, Tenn. (245.8m-1220kc) 7-10 p. m. musical.
 WEBB Chicago, Ill. (365.6m-820kc) 7-8 p. m. orchestra, artists; 9-11, Uptown theater stage presentation.
 WENR Chicago, Ill. (288.3m-1040kc) 6 p. m. organ; 8, classical program; 9:30, popular program.
 WFAA Dallas, Tex. (499.7m-600kc) 6:30 p. m. talk; 8:30, musical; 11-12, theater hour.
 WGN Chicago, Ill. (305.9m-980kc) 6:10 p. m. Punch and Judy; 6:50, old fashioned amateck; 8, WEAF; 9, musical; 9:30, recital; 10, Sam 'n' Henry; 10:10, music box; 10:20, musical; 10:50, concert.
 WHAS Louisville, Ky. (461.3m-650kc) 7:30 p. m. music; 8-10, WEAF.
 WHB Kansas City, Mo. (336.9m-890kc) 7 p. m. dinner concert; 8, evening concert.
 WHO Des Moines, Iowa (535.4m-560kc) 6:30 p. m. orchestra; 8:30, string trio.

TRY IT 30 DAYS FREE BEFORE YOU BUY

FACTORY PRICES—SAVE 50%
 Choice of beautiful cabinets offered

8 tube one dial MIRACO
 TRADE MARK REGISTERED

ALL METAL SHIELDED CHASSIS

Only \$69.75
 Retail List Completely Assembled

MAGNIFICENT TONE~SUPER SELECTIVE~POWERFUL DISTANCE GETTER

All Electric or Battery Set!

America's big, old, reliable Radio Corporation* (8th successful year) guarantees its big, powerful, latest 6, 7 and 8 tube Miraco sets to give "the finest, most enjoyable performance obtainable in high grade radios." Unless 30 days' use in your home fully satisfies you and everybody who hears it that a Miraco is unbeatable at any price for beautiful, clear cathedral tone, razor-edge selectivity, powerful distance reception, easy operation, etc.—*don't buy it! Your verdict final*—absolutely no strings to this. Save or make lots of money on sets and equipment by writing for testimony of nearby users and **Amazing Special Factory Offer.**

choice. Many thousands of Miraco users—who bought after thorough comparisons—testify they enjoy programs Coast to Coast, Canada to Mexico, loud and clear—with the magnificent cathedral tone quality of costliest sets. Don't confuse Miraco's with cheap, "squawky" radios. Miraco's have finest parts, latest approved shielding, metal chassis, etc.—as used in \$200 sets.

Big Discounts to User-Agents

7 tube one dial METAL SHIELDED CHASSIS \$49.75 RETAIL LIST

MIRACO "Powerplus" sets—both 8 and 7 tube models—have magnificently beautiful, clear cathedral tone quality. Turn one dial for stations every where. Ultra-selective, Miraco multi-stage distance amplification gives "power-plus" on far-off stations. Latest all-metal shielded chassis. Illuminated dial. Fully guaranteed. Try one free for 30 days! Choice of beautiful cabinets.

Run from Light Socket or Batteries
 Miraco's work equally fine on electric house current or with batteries. Take your

Deal Direct with Big Reliable Makers
 Your Miraco reaches you completely assembled, rigidly tested, fully guaranteed. Easy to connect and operate. 30 days free trial. 3 year guarantee if you buy. Choice of beautiful consoles [with latest built-in orthophonic type speakers having 8 feet of tone travel] and table cabinets, also offered. You take no risk, you insure satisfaction, you enjoy rock-bottom money-saving prices by dealing direct with one of radio's oldest, most successful builders of fine sets.

MIRACO Radio gets em Coast to Coast

6 tube Super \$36.75 RETAIL LIST

Famous powerful big Miraco Super 6, 1928 model—ultra selective. Thousands find it outperforms and outdistances sets of much higher price. Fully Guaranteed.

USER-AGENTS! Make big profits showing your Miraco set to friends
 *MIDWEST RADIO CORPORATION, Cincinnati, O.

BEAUTIFULLY ILLUSTRATED CATALOG AND AMAZING SPECIAL OFFER
 SEND NO MONEY.—30 DAYS' TRIAL Special Wholesale Price Offer to User-Agents, Bank References and testimony of nearby Miraco users—sent with catalog.

Electrify Any Radio with MIDWEST NO-BATTERY AC Light Socket Power Units

"A", "B" and "C" power, direct from light socket, without batteries! Write for Midwest prices and discounts. Midwest Units are highest grade—lastingly dependable, quiet in operation, fully guaranteed.

Free!

Mail Coupon Right Now

MIDWEST RADIO CORPORATION
 Pioneer Builders of Sets
 427-A Miraco Building, Cincinnati, Ohio.

Without obligation, send free catalog, AMAZING SPECIAL OFFER, testimony of nearby Miraco users.

NAME _____

ADDRESS _____

THIS COUPON IS NOT AN ORDER

WHT Chicago, Ill. (416.4m-720kc) 7-10 p. m. program; 11-1 a. m., popular program.
 WJBO Chicago, Ill. (416.4m-720kc) 6-7 p. m. program; 10-11, popular.
 WJAZ Chicago, Ill. (263m-1140kc) 7 p. m. orchestra; 9, studio program.
 WJJD Chicago, Ill. (365.6m-820kc) 8-9 p. m. Mooseheart hour; 11-1, Palmer House Victorians; Carroll and Grady.
 WLAC Nashville, Tenn. (226m-1330kc) 9 p. m. soprano; 10, studio program.
 WLIB Chicago, Ill. (306m-880kc) 7 p. m. dinner concert; 11-12:15, trollic.
 WLS Chicago, Ill. (344.6m-870kc) 6:30 p. m. orchestra; 7:20, Duo; 7:30, Don Malin.
 WMAQ Chicago, Ill. (447.5m-670kc) 7 p. m. orchestra; 8, program; 12, popular program.
 WOAI San Antonio, Tex. (302.8m-890kc) 8:30 p. m. players.
 WOC Davenport, Ia. (374.8m-800kc) 8 p. m. WEAF; 9, musicale.
 WOW Omaha, Nebr. (508.2m-590kc) 6 p. m. classical program; 6:50, Randall's Royal Fontenelle orchestra; 9, popular and old time music.
 WSB Atlanta, Ga. (475.9m-630kc) 7 p. m. WEAF; 8, WEAF; 10:45, orchestra.
 WSCB Chicago, Ill. (232.4m-1290kc) 5-7 p. m. Hugh Swift and his Serenaders; dinner concert; 9:30-1, popular program.
 WSM Nashville, Tenn. (340.7m-880kc) 7:15-8 p. m. dinner concert; 8, WEAF; 9, program.
 WTMJ Milwaukee, Wis. (293.9m-1020kc) 7-12 mid. program.

Mountain Standard Time Stations

KOA Denver, Colo. (325.9m-920kc) 7:30 p. m. farm question box.

Pacific Standard Time Stations

KFI Los Angeles, Calif. (468.5m-640kc) 7-8 p. m. serenaders; 8-9, program; 9-10, orange network; 10-11, dance orchestra.
 KFWD Hollywood, Calif. (361.2m-830kc) 6-7 p. m. dinner hour; 8-9, studio program; 9-10 p. m. musicale; 10-11 p. m. Rainbow hour.
 KGO Oakland, Calif. (384.4m-780kc) 6-6:55 p. m. Stanislas Bem's Little symphony; 8-9, Pilgrims; 9-10, National Broadcasting Company; 10, Vagabonds, N. B. C.
 KGW Portland, Ore. (491.5m-610kc) 8-9 p. m., educational program; 9, National Broadcasting Company; 10, orchestra.
 KHJ Los Angeles, Calif. (405.2m-740kc) 6:30-7:30 p. m. children's hour; 8-10, new artists.
 KJR Seattle, Wash. (348.6m-860kc) 8 p. m. studio program; 10-11, orchestra.
 KNX Hollywood, Calif. (336.9m-890kc) 8 p. m. program; 9:30, musicale; 10, trollic.
 KPO Los Angeles, Calif. (422.3m-710kc) 7-7:30 p. m. orchestra; 8-9, Fireside hour; 9-10, orange chain; 10-11, orchestra.

Tuesday, silent night for: CFCA, KFH, KKLX, WLIT, WOS, WSMB, WTAC.

WEDNESDAY, OCTOBER 5

Eastern	Central	Mountain	Pacific
7 p.m.	6	5	4
WTIC (535.4m-560kc) Bryant and Chapman Early Birds.			
7:45	6:45	5:45	4:45
WIBO (416.4m-720kc) Bernice Ozmun, "Arabic Love Songs."			
8	7	6	5
WTJ (454.3m-660kc) WBZ (333.1m-900kc) KDKA (315.9m-950kc), KYW (526m-570kc), Sylvania Foresters.			
8:30	7:30	6:30	5:30
WHAS (461.3m-650kc) Myer Green, violinist.			
WLS (344.6m-870kc) Oriental male quartet.			
9	8	7	6
WDBM (389.4m-770kc) National male quartet.			
WOR, Newark, N. J.			
WOR (422.3m-710kc), WEAN (319m-940kc), WNAC (352.7m-850kc) WFBL (258.5m-1160kc), WMAK (545.1m-550kc) WCAU (277.6m-1080kc), WJAS (270.1m-1110kc), WADC (296.9m-1010kc), WAIU (282.8m-1060kc), WKRC (333.1m-900kc).			

WGHP (319m-940kc), WMAQ (447.5m-670kc), KOIL (277.6m-1080kc), KMOX (299.8m-1000kc), WOWO (228.9m-1310kc), WCAO (384.4m-780kc), Columbia chain.
 9:10 8:10 7:10 6:10
 WRVA (254.1m-1180kc) Mrs. Herbert Powell, soprano.
 9:30 8:30 7:30 6:30
 WHAS (461.3m-650kc) Virginia Vetter's entertainers.
 WHO (535.4m-550kc) Kate Miller, whistler.
 10 9 8 7
 WOR, Newark, N. J.
 WOR (422.3m-710kc), WEAN (319m-940kc), WNAC (352.7m-850kc) WFBL (258.5m-1160kc), WMAK (545.1m-550kc), WCAU (277.6m-1080kc), WJAS (270.1m-1110kc), WADC (296.9m-1010kc), WAIU (282.8m-1060kc), WKRC (333.1m-900kc), WGHP (319m-940kc), WMAQ (447.5m-670kc), KOIL (277.6m-1080kc), KMOX (299.8m-1000kc), WOWO (228.9m-1310kc), WCAO (384.4m-780kc), Columbia chain.
 WRVA (254.1m-1180kc) 20th Century club.
 10:30 9:30 8:30
 WCCO (405.2m-740kc) Thelma Cummins, reader; Yone Kishi, whistler.
 WDAF (370.2m-810kc) Cavaliers.
 WIO (535.4m-550kc) Royal American saxophone sextette.
 WSM (340.7m-880kc) Second Anniversary celebration; trollic.
 11 10 9 8
 KFI (468.5m-640kc) Scotch program.
 12 mid 10 9 8
 KGO (384.4m-780kc), KFI (468.5m-640kc), KPO (422.3m-710kc), KGW (491.5m-610kc), KOMO (305.9m-980kc) Retold tales, "The Young Man With the Cream Tarts."

Regular Wednesday Features

Eastern Time Stations

KDKA Pittsburgh, Pa. (315.6m-950kc) 7:30 p. m. program; 8, WJZ; 9, WJZ.
 WBAL Baltimore, Md. (285.5m-1050kc) 7:30-8:30 p. m. vocal recital; 8:30, recital; 9, WJZ.
 WBZ Springfield, Mass. (333.1m-900kc) 6:30 p. m. ensemble; 8, WJZ; 8:30, trio; 9, WJZ; 10, artists; 10:30, orchestra.
 WCAE Pittsburgh, Pa. (516.9m-580kc) 6 p. m. dinner concert; 8, program; 9, WEAF; 11, orchestra.
 WCAU Philadelphia, Pa. (336.9m-890kc) 7 p. m. program; 9:30, musicale; 10, orchestra; 11, Cheer-up club.
 WCSH Portland, Me. (361.2m-830kc) 8 p. m. WEAF.
 WEF New York, N. Y. (491.5m-610kc) 7:30 p. m. South Sea Islanders, WTAC; 8:30, organ masters, WEEL, WLIT, WRC; 9, time, WEEL, WJAR, WRC, WLIT, WCAE, WTAM, WWJ, WSAI, KSD, WGY; 9, Ipana Troubadours, WEEL, WGR, WRC, WCAE, WWJ, WLIB, KSD, WCCO, WGY; 9:30, Goodrich Silvertown Cord orchestra, WEEL, WJAR, WTAC, WGR, WCSH, WCAE, WTAM, WWJ, WSAI, WGN, KSD, WOC, WCCO, WHAS, WSM, WSB, WMC, WLIT, WDAF; 10:30, orchestra, WRC, WSAI; 11, orchestra, WRC.
 WEEL Boston, Mass. (447.5m-670kc) 8 p. m. program; 8:30, WEAF; 10:30, cruising the air.
 WFI Philadelphia, Pa. (405.2m-740kc) 7:15 p. m. questions; 8:30-11:30, WEAF.
 WFLA Clearwater, Fla. (365.6m-820kc) 8:30 p. m. open house; 9:45, dance program.
 WGBS New York, N. Y. (348.6m-860kc) 6:45 p. m. entertainers.
 WGHP Detroit, Mich. (319m-940kc) 6 p. m. dinner concert; 8, Columbia chain.
 WGR Buffalo, N. Y. (302.8m-890kc) 7:45 p. m. piano lessons; 8, orchestra; 9, WEAF; 11:05-12 mid., music.
 WGY Schenectady, N. Y. (379.5m-790kc) 8:30, WEAF; 9:30, Mandoliers; 10, studio program.
 WJAX Jacksonville, Fla. (336.9m-890kc) 8, WJZ; 9, recital; 10, dance orchestra.
 WHN New York, N. Y. (394.5m-760kc) 6:30 p. m. orchestra; 11:30, Silver Slipper orchestra.
 WJR-WCX Detroit, Mich. (440.9m-880kc) 7 p. m. travel hour; 9, dance orchestra; 10:15, song review.

Modern

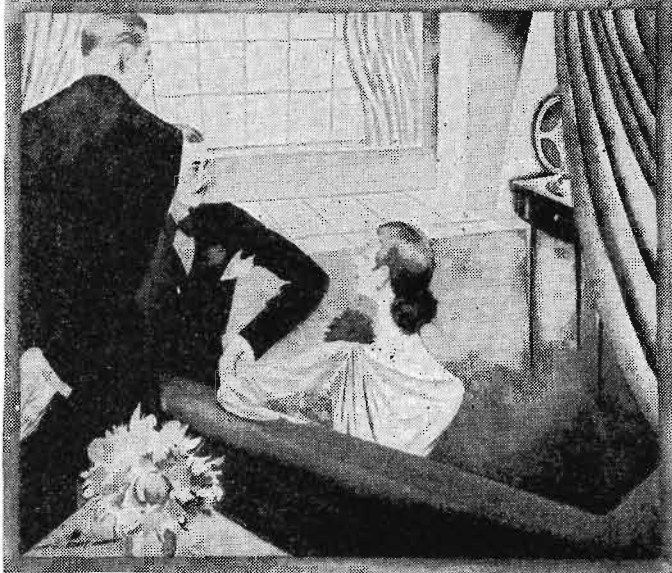

Radio is better with Battery Power

NOT because they are new in themselves, but because they make possible modern perfection of radio reception, batteries are the modern source of radio power.

Today's radio sets were produced not merely to make something new, but to give you new enjoyment. That they will do. New pleasures await you; more especially if you use Battery Power. Never were receivers so sensitive, loud-speakers so faithful; never has the need been so imperative for pure DC, Direct Current, that batteries provide. You must operate your set with current that is smooth, uniform, steady. Only such current is noiseless, free from disturbing sounds and false tonal effects. And only from batteries can such current be had.

So batteries are needful if you would bring to your home the best that radio has to offer. Choose the Eveready Layerbilt "B" Battery No. 486, modern in construction, developed exclusively by Eveready to bring new life and vigor to an old principle—actually the best and longest-lasting Eveready Battery ever built. It gives you Battery Power for such a long time that you will find the cost and effort of infrequent replacement small indeed beside the modern perfection of reception that Battery Power makes possible.

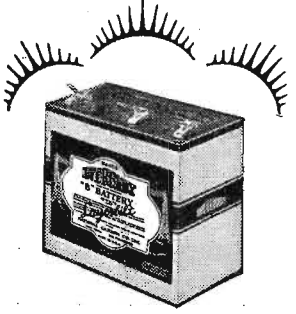

Here is the Eveready Layerbilt "B" Battery No. 486, Eveready's longest-lasting provider of Battery Power.

Tuesday night is Eveready Hour Night—9 P. M., Eastern Standard Time

- WEAF—New York
 - WJAR—Providence
 - WEEL—Boston
 - WFI—Philadelphia
 - WGR—Buffalo
 - WCAE—Pittsburgh
 - WSAI—Cincinnati
 - WTAM—Cleveland
 - WWJ—Detroit
 - WGN—Chicago
 - WOC—Davenport
 - WCCO—(Minneapolis) St. Paul
 - KSD—St. Louis
 - WDAF—Kansas City
 - WRC—Washington
 - WGY—Schenectady
 - WHAS—Louisville
 - WSB—Atlanta
 - WSM—Nashville
 - WMC—Memphis
- Pacific Coast Stations—
 9 P. M., Pacific Standard Time
- KPO—KGO—San Francisco
 - KFOA—KOMO—Seattle
 - KFI—Los Angeles
 - KGW—Portland

NATIONAL CARBON COMPANY, INC.
 New York  San Francisco
 Unit of Union Carbide and Carbon Corporation



The air is full of things you shouldn't miss

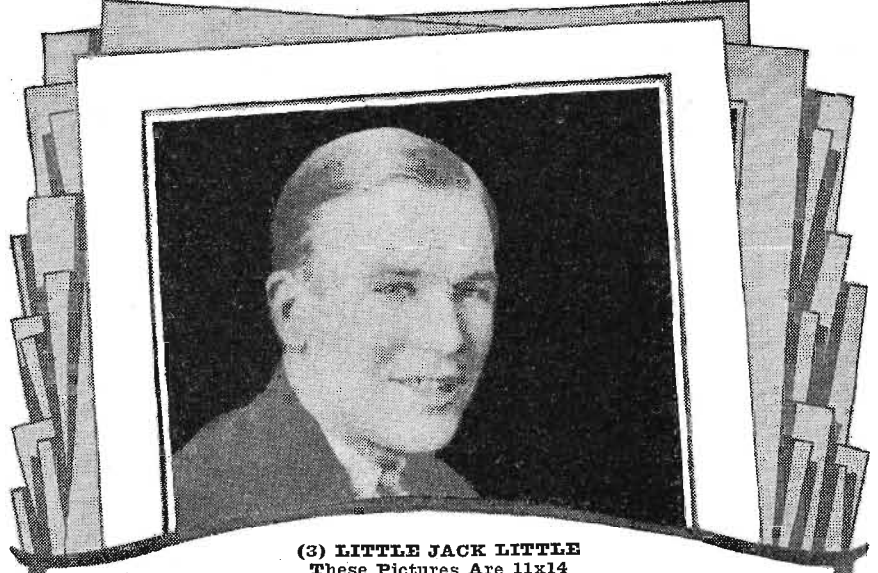

(3) LITTLE JACK LITTLE
 These Pictures Are 11x14
 First Time Offered

Free Photogravures of Your Favorite Artists

By special arrangement Radio Digest is now able to offer its readers a great opportunity to secure a selection of twelve fine photogravures of their favorite Radio stars. These photogravures can only be compared with the finest photos obtainable. See coupon below.

Select Your Favorites From the Gallery of Radio Stars

- 1 Wendell Hall, king of ukulele ditties
- 2 Graham McNamee, 1925 Gold Cup announcer
- 3 Little Jack Little, crooning piano balladist
- 4 Billy B. Van, the Sunshine Man
- 5 Coon-Sanders' Original "Nighthawks"
- 6 George Hay, 1924 Gold Cup announcer
- 8 Ford and Glenn, Lullaby Boys of WLS
- 9 "Roxey" Rothal of WEAF chain fame
- 10 The Hired Hand, famous "Substitute Announcer" of WJAP
- 11 Jerry Sullivan, of Chi-CAW-go fame
- 12 Bob Emery, Big Brother of WEEL
- 13 "Bill" W. C. Hay, ex-KFKX, now of WLIB
- 14 Happiness Boys, jovial singers of WEAF
- 15 Lamdin Kay, "Little Colonel" of WSB
- 16 Leo Fitzpatrick, "Merry Old Chief," WJR
- 17 Henry Field, 1925 Gold Cup runner-up
- 18 Al Carney, organ favorite at WHT
- 19 Earl E. May, 1926 Gold Cup announcer
- 20 Vincent Lopez, No. 1 Pennsylvania orchestra
- 21 E. L. Tyson, pleasing voice at WWJ
- 22 Bert Davis, "Clown of the Air"
- 23 Art Gillham, "The Whispering Pianist"
- 24 The Sunflower Girl of WJAP
- 25 Harry Ehrhart, "Dream Daddy," of WLIT
- 26 Correll and Gosden of "Kinky Kids Parade" fame, at WEBB and other stations
- 27 Norman Brokenshire, popular at WRC, WJZ
- 29 Jane Novak, Blues Singer of Twin Cities, WCCO
- 30 Jean Sargent, the original, now at WHT
- 31 Ralph Emerson, popular organist at WLS
- 32 Edna Adams, of KPRC
- 33 Pat Barnes, vaudeville announcer at WHT
- 38 Walter Wilson, "Uncle Bob" of KYW
- 40 Ray-O-Vac Twins, known country-wide
- 41 Art Linick, KYW's Mrs. Schlagenhauer
- 42 Fred Hamm of WTAS, now WLIB, fame

Suitable for Framing or Placing in Your Album

Send Coupon Now

Your Radio set gives you their voices. Their pictures add very much to your complete entertainment.

ACT TODAY
 RADIO DIGEST PUBLISHING CO.
 510 N. Dearborn St., Chicago, Ill.

Radio Digest, 510 N. Dearborn St. 6-15-27
 Chicago, Ill.
 I am enclosing Three Dollars for a One Year's Subscription to Radio Digest. I Am to Receive Free the Selection of Twelve Photogravures Listed Below. This Offer Good Only on Subscriptions Sent Direct.
 Name
 Address
 City State
 In order to insure prompt shipment, please give us fourteen numbers, the last two of which we may substitute if necessary. Order by Number.

WJZ New York, N. Y. (454.2m-660kc) 6 p. m. orchestra; 8, Foresters, WBZ, KDKA, KYW; 8:30, Davis Saxophone sextet; 9, Maxwell House hour, WBZ, KDKA, KYW; WBAL, WLR, WLW, WHAS, WBB, WMC, WSM, WJAX, WTMJ, WBT; 10, to be announced; 10:30, orchestra.

WLIT Philadelphia, Pa. (405.2m-740kc) 8 p. m. WEAF; 8:30, WEAF; 9:02, Stanley theater; 10, orchestra; 10:30, WEAF.

WLW Cincinnati, Ohio (428.3m-700kc) 7:30 p. m. farm radio council talk; 8, program; 10, trio; 11, organist.

WMAK Buffalo, N. Y. (545.1m-550kc) 6:15 p. m. dinner music; 8, band; 9, studio program.

WMCA New York, N. Y. (370.2m-810kc) 6:30 p. m. orchestra; 10, musicale; 12:30, frolic club.

WMSG New York, N. Y. (236m-1270kc) 9-11:30 p. m. program.

WNAZ Boston, Mass. (352.7m-850kc) 7:30-10 p. m. program.

WOO Philadelphia, Pa. (508.2m-590kc) 7:30 p. m. musicale; 8:30, music; 9:25, orchestra.

WOR Newark, N. J. (422.3m-710kc) 6:15-11 p. m. program; 11, orchestra.

WGR New York, N. Y. (422.3m-710kc) 6:15-11 p. m. program; 11, orchestra.

WPG Atlantic City, N. J. (272.6m-1100kc) 7:05 p. m. dinner music; 7:35, minstrels; 9:10, studio program; 10, band; 10, marine studio; 11:30, organ.

WRC Washington, D. C. (468.5m-640kc) 7:30-11, WEAF.

WRVA Richmond, Va. (254.1m-1180kc) 8 p. m. musicale; 9, WEAF; 10, WEAF.

WSAI Cincinnati, Ohio (361.2m-830kc) 8:01 p. m. program; 10, orchestra.

WIBC Chicago, Ill. (232.4m-1290kc) 5-7 p. m. Hugh Swift and his Serenaders; dinner concert; 9:30-1, popular music.

WSEA Norfolk, Va. (263m-1140kc) 7 p. m. dinner concert; 10, dance music.

WTAG Worcester, Mass. (516.9m-580kc) 7:30 p. m. WEAF; 8, musicale; 9, program; 9:30, WEAF; 10:30, dance orchestra.

WTAM Cleveland, Ohio (399.8m-750kc) 6 p. m. orchestra; 7, talks; 8, studio recital; 8:30, WEAF; 10:30, studio program; 11, orchestra.

WTIC Hartford, Conn. (535.4m-560kc) 7-11 p. m. program.

WWJ Detroit, Mich. (352.7m-850kc) 6 p. m. dinner concert; 7:30, musicale; 8, WEAF; 9, WEAF.

WWNC Asheville, N. C. (296.9m-1010kc) 7 p. m. dinner music.

11:45 10:45 9:45 8:45

WSB (475.9m-630kc) Organ recital, Dr. Chas. A. Sheldon.

12 mid. 11 10 9

KGO (384.4m-780kc), KFI (468.5m-640kc), KPO (422.3m-710kc), KGW (491.5m-610kc), KOMO (305.9m-980kc), Ray Bailey string jazz orchestra.

Regular Thursday Features

Eastern Time Stations

KDKA Pittsburgh, Pa. (315.6m-950kc) 7:30, sketch; 8, WJZ; 9-11, WJZ.

WBAL Baltimore, Md. (285.5m-1050kc) 6:30 p. m., dinner orchestra; 7:30, musicale; 8, ensemble; 9, dance orchestra.

WBZ Springfield, Mass. (333.1m-900kc) 7:34 p. m. orchestra; 8, N. B. C.; 8:30, musicale; 10, orchestra.

WCAE Pittsburgh, Pa. (516.9m-580kc) 6 p. m. dinner concert; 9, WEAF; 10, WEAF; 11, club revue.

WCSH Portland, Me. (361.2m-830kc) 7:30 p. m. WEAF.

WDBO Orlando, Fla. (288.3m-1040kc) 9:30 p. m. dance program.

WEAF New York, N. Y. (491.5m-610kc) 6-12 mid. dinner music; Coward Comfort hour; Hoover Sentinels; time; Cluquot Club Eskimos; Smith Brothers.

WEEL Boston, Mass. (447.5m-670kc) 7:30 p. m. musicale; 9, WEAF; 10, WEAF; 11:05, weather.

WFI Philadelphia, Pa. (405.2m-740kc) 8 p. m. WEAF.

WGBS New York, N. Y. (348.6m-860kc) 7:30 p. m. orchestra; 8:50, program; 10:30, dance orchestra.

WGHF Detroit, Mich. (319m-940kc) 8 p. m., organ; 9, program; 9:30, orchestra.

WGR Buffalo, N. Y. (302.8m-990kc) 8-9 p. m. ensemble; 9:30, concert; 11:05, supper music.

WGY Schenectady, N. Y. (379.5m-790kc) 7:30 p. m.

story of America; 8, WEAF; 9, WEAF; 10, program; 11, WEAF; 11:30, organ.

WHAR Atlantic City, N. J. (272.6m-1100kc) 7:45 p. m. talk; 7:55, trio.

WHK Cleveland, Ohio (265.3m-1130kc) 6:30 p. m. dinner orchestra; 7:30, I. B. S. A. program; 9:45, banjoists; 10, program.

WHN New York, N. Y. (394.5m-760kc) 6:20-12 mid. program; 12, Cotton club orchestra.

WIP Philadelphia, Pa. (508.2m-590kc) 8 p. m. program; 11:05, orchestra.

WJAX Jacksonville, Fla. (336.9m-890kc) 8 p. m. markets.

WJR Detroit, Mich. (440.9m-680kc) 6:30 p. m. Petite symphony; 8, WJZ; 11, orchestra.

WJZ New York, N. Y. (454.2m-660kc) 7 p. m. Bill Whipple of Sweet Meadows, WBZ, WRC; 7:15, orchestra; 8, R. C. A. Radiotrons, WBZ, KDKA, WBB; 9, quartet, KDKA, KYW, WJR; 9:30, Spotlight hour, WJR, WOC, WTMJ, KYW, KDKA, SPHAM; 10:30, orchestra.

WLW Cincinnati, Ohio (428.3m-700kc) 7 p. m. orchestra; 7:30, Crosley Cossacks; 11, Tommy and Irene.

WMAK Buffalo, N. Y. (545.1m-550kc) 6:30 p. m. dinner music; 10:30, musicale.

WMCA New York, N. Y. (370.2m-810kc) 6:30 p. m. orchestra; 11, orchestra; 12, Broadway nite.

WOR Newark, N. J. (422.3m-710kc) 6:15 p. m. ensemble; 9, Columbia chain; 11, orchestra.

WPG Atlantic City, N. J. (272.6m-1100kc) 8:15 p. m. organ; 9:30, Breaking the Waves; 10, Movie broadcast; 11, orchestra; 11:30, dance orchestra.

WRC Washington, D. C. (468.5m-640kc) 7 p. m. WJZ; 8-11, WEAF; 11, band.

WRVA Richmond, Va. (254.1m-1180kc) 8 p. m. program; 11:30, Carry Me Back to Old Virginia.

WSAI Cincinnati, Ohio (361.2m-830kc) 7 p. m. WEAF; 8:01, studio concert.

WSEA Norfolk, Va. (263m-1140kc) 7 p. m. dinner music; 8:30, studio recital; 10, orchestra.

WTAG Worcester, Mass. (516.9m-580kc) 8 p. m. travel talk; 9, WEAF; 10, WEAF.

WTAM Cleveland, Ohio (399.8m-750kc) 6:15 p. m. orchestra; 8, studio program; 11, orchestra.

WTIC Hartford, Conn. (535.4m-560kc) 6:30 p. m. WEAF; 7, organ; 7:30, WEAF; 8:30, orchestra.

WWJ DETROIT, Mich. (352.7m-850kc) 6 p. m. dinner concert; 8, WEAF.

WWNC Asheville, N. C. (296.9m-1010kc) 7 p. m. dinner concert; 8:30, talk; 9-11, program.

Central Standard Time Stations

KMA Shenandoah, Ia. (394.5m-760kc) 6 p. m. music; 8, Dixie Girls.

KMMJ Clay Center, Nebr. (379.5m-790kc) 6 p. m. ensemble; 8, musicale; 9, organ.

KOIL Council Bluffs, Ia. (277.6m-1080kc) 6:03 p. m. Mona Motor Oil orchestra; 6:30, organ recital; 7:30, program; 11, orchestra.

KPRC Houston, Tex. (296.9m-1010kc) 7:30-9:30 p. m. studio concert.

KSD St. Louis, Mo. (545.1m-550kc) 6 p. m. WEAF.

KTHS Hot Springs National Park, Ark. (384.4m-780kc) 8:30-9:30 p. m. feature program; 9:45, program.

KYW Chicago, Ill. (526m-570kc) 7-8 p. m. program; 8-9:30, WJZ; 9:30, program; 10:32, Congress carnival.

WBAP Ft. Worth, Tex. (499.7m-600kc) 7:30-8:30 p. m. musicale; 9:30-11, musical comedy program, Royal orchestra; 11-12, John Josey, organist.

WBBM Chicago, Ill. (389.4m-770kc) 7-11 p. m. program.

WBCN Chicago, Ill. (288.3m-1040kc) 7 p. m. program.

WCBD Zion, Ill. (344.6m-870kc) 8 p. m. Cornet quartet, vocal solos, trio.

WCCO Minneapolis-St. Paul, Minn. (405.2m-740kc) 7:30 p. m. program.

WCFL Chicago, Ill. (483.6m-620kc) 6 p. m. labor hour; 7, trio; 8, classical music; 8-12, popular hour.

WDAF Kansas City, Mo. (370.2m-810kc) 6 p. m. School of the Air; 7:30, WEAF; 11:45-1, Night-hawk frolic.

Central Standard Time Stations

KFAB Lincoln Nebr. (309.1m-970kc) 5:30-6:30 p. m. dinner concert; 8:30-11, orchestra.

KMA Shenandoah, Ia. (394.5m-760kc) 8 p. m. program.

KPRC Houston, Tex. (296.9m-1010kc) 7:30 p. m. Jack Willrich's dance orchestra.

KSD St. Louis, Mo. (545.1m-550kc) 7 p. m. WEAF.

KTHS Hot Springs, Ark. (384.4m-780kc) 8:30 p. m. chamber music; 9:30, frolic.

KYW Chicago, Ill. (526m-570kc) 7-7:30 p. m. WJZ; 7:30-8, musicale; 8, WJZ; 9, program; 10:32, Congress carnival.

WBBM Chicago, Ill. (389.4m-770kc) 7 p. m. dinner concert; 8-11, popular program.

WCCO Minneapolis-St. Paul, Minn. (405.2m-740kc) 8 p. m. WEAF.

WCOA Pensacola, Fla. (249.9m-1200kc) 8 p. m. program.

WDAF Kansas City, Mo. (370.2m-810kc) 7:30-9:30 p. m. WEAF; 9:30, Cavaliers; 11:45-1 a. m., Night-hawk frolic.

WDD Chattanooga, Tenn. (245.8m-1220kc) 7-10 p. m. music.

WEBH Chicago, Ill. (365.6m-820kc) 7 p. m., WEAF; 7:30, orchestra; 9-11, program; 12, revue.

WGN Chicago, Ill. (305.9m-980kc) 8:30 p. m., WEAF; 9:30, musicale; 10, "Sam 'n' Henry"; 10:10, Music Box; 10:20, musicale; 10:30, musicale.

WHAS Louisville, Ky. (451.3m-650kc) 7:30 p. m., program; 8, WEAF; 8:30, concert.

WHB Kansas City, Mo. (336.9m-890kc) 7-8 p. m. string trio.

WHO Des Moines, Ia. (535.4m-560kc) 6:30 p. m. Little symphony; 8:30, Harmony Twins; 9:30, orchestra.

WHT Chicago, Ill. (416.4m-720kc) 8-10 p. m. program.

WIBO Chicago, Ill. (416.4m-720kc) 6-7 p. m.; 10-11.

WJJD Chicago, Ill. (365.6m-820kc) 8-9 p. m. children's musical hour; 11-12, Victorians.

WLAC Nashville, Tenn. (226m-1330kc) 7 p. m. classical program; 8, popular music.

WLIB Chicago, Ill. (360m-980kc) 7-8 p. m. string quintet.

WLS Chicago, Ill. (344.6m-870kc) 7:30 p. m. orchestra; 8, choral music; 10-12, Haymakers.

WMAQ Chicago, Ill. (447.5m-670kc) 7 p. m. orchestra; 9:10, musicale; 12, popular program.

WQJ Chicago, Ill. (447.5m-670kc) 9:45-12, orchestra.

WQAF San Antonio, Tex. (302.8m-990kc) 8:30-9:30 p. m. Kelvinator hour.

WOC Davenport, Ia. (374.8m-800kc) 7:30 p. m. WEAF; 8:30, musicale.

WSB Atlanta, Ga. (475.9m-630kc) 7:30, organ; 8:30, WEAF.

WSM Nashville, Tenn. (340.7m-860kc) 7:15 p. m. dinner concert; 9, WEAF; 9:30, music.

WSMB New Orleans, La. (32.4m-930kc) 8:30-10:30 p. m. Public School of the Air program; features.

WTMJ Milwaukee, Wis. (293.9m-1020kc) 7 p. m. WJZ; 8, band; 10, trio; 10:30, dance music.

Mountain Standard Time Stations

KOA Denver, Colo. (325.9m-920kc) 8 p. m. Scheuerman's Colorado orchestra; 8:15, studio program.

Pacific Standard Time Stations

KFI Los Angeles, Calif. (468.5m-640kc) 7:30 p. m. Nick Harris; 8-9, program, California Petroleum corp.; 9, orange network; 10, classic music.

KFWB Hollywood, Calif. (361.2m-830kc) 6-7 p. m. dinner hour; 7:50, news; 8:9, features; 9-10, orchestra; 10-11, Rainy orchestra.

KGO Oakland, Calif. (384.4m-780kc) 6-6:55 p. m. Stanislas Bem's Little Symphony; 8, vaudeville; 9, National Broadcasting company; 10, orchestra.

KGW Portland, Ore. (491.5m-610kc) 8-9 p. m. concert; 9-10, National Broadcasting company.

KHJ Los Angeles, Calif. (405.2m-740kc) 6:30-7:30 p. m. children's hour; 8:15-10, musicale.

KJR Seattle, Wash. (348.6m-860kc) 6:30 p. m. dinner concert; 8-10, studio program.

KLX Oakland, Calif. (508.2m-590kc) 6:30-7 p. m. Athens Athletic club orchestra; 8-9, educational program; 9-10, program.

KNK Hollywood, Calif. (336.9m-890kc) 7-10 p. m. features; 11, Hotel Ambassador.

KPO San Francisco, Calif. (422.3m-710kc) 6:30-7 p. m. States Restaurant orchestra; 7-7:30, Rudy Seiger's Fairmont hotel concert orchestra; 8-9, Atwater Kent artists; 9-10, orange network; 10-11, States Restaurant orchestra.

Wednesday, silent night for: WBAP, WCBM, WFAA, WFI, WGBF, WGBS, WIP, WOW, WRR.

THURSDAY, OCTOBER 6

Headliners

Eastern	Central	Mountain	Pacific
5 p.m.	4	3	2
CFCA (357m-840kc) dedication program, Carillon at Memorial tower, U. of Toronto.			
8	6	5	4
WMBB (252m-1150kc) Hilda Hinrichs; semi-classical program.			
WRVA (254.1m-1180kc) Rappahannock Valley night.			
WTIC (535.4m-560kc) Fields Blue Boys.			
9	8	7	6
WCRD (344.6m-870kc) Brass quartet.			
WCCO (405.2m-740kc) Portal Players in "Casino Gardens."			
9:30	8:30	7:30	6:30
WBBM (389.4m-770kc) Doings of the Brown Family.			
WFAA (499.7m-600kc) Billie Noland, whistling pianist.			
10	9	8	7
KTHS (384.4m-780kc) State contest finals in the Atwater Kent National Audition.			
WGJ (379.5m-790kc) Stuart Swart, pianist.			
10:05	9:05	8:05	7:05
WIP (508.2m-590kc) Schwab's Banjo Boys.			
10:30	9:30	8:30	7:30
WCCO (405.2m-740kc) Selections from popular operas.			
11	10	9	8
WIBO (416.4m-720kc) Lillian Brodahl Smith, Scandinavian stories.			
11:30	10:30	9:30	8:30
WGY (379.5m-790kc) Organ recital, Floyd Water.			

Regular Thursday Features

Eastern Time Stations

KDKA Pittsburgh, Pa. (315.6m-950kc) 7:30, sketch; 8, WJZ; 9-11, WJZ.

WBAL Baltimore, Md. (285.5m-1050kc) 6:30 p. m., dinner orchestra; 7:30, musicale; 8, ensemble; 9, dance orchestra.

WBZ Springfield, Mass. (333.1m-900kc) 7:34 p. m. orchestra; 8, N. B. C.; 8:30, musicale; 10, orchestra.

WCAE Pittsburgh, Pa. (516.9m-580kc) 6 p. m. dinner concert; 9, WEAF; 10, WEAF; 11, club revue.

WCSH Portland, Me. (361.2m-830kc) 7:30 p. m. WEAF.

WDBO Orlando, Fla. (288.3m-1040kc) 9:30 p. m. dance program.

WEAF New York, N. Y. (491.5m-610kc) 6-12 mid. dinner music; Coward Comfort hour; Hoover Sentinels; time; Cluquot Club Eskimos; Smith Brothers.

WEEL Boston, Mass. (447.5m-670kc) 7:30 p. m. musicale; 9, WEAF; 10, WEAF; 11:05, weather.

WFI Philadelphia, Pa. (405.2m-740kc) 8 p. m. WEAF.

WGBS New York, N. Y. (348.6m-860kc) 7:30 p. m. orchestra; 8:50, program; 10:30, dance orchestra.

WGHF Detroit, Mich. (319m-940kc) 8 p. m., organ; 9, program; 9:30, orchestra.

WGR Buffalo, N. Y. (302.8m-990kc) 8-9 p. m. ensemble; 9:30, concert; 11:05, supper music.

WGY Schenectady, N. Y. (379.5m-790kc) 7:30 p. m.

Uses Q. R. S. or Raytheon 85 Mil. Tube

new advanced TYPE 180 volt "B" Eliminator

Guaranteed 2 YEARS

TRY IT FREE

For 110 Volt 60 Cycle A.C.

Brand new—radically different in design—obviously better—and guaranteed for 2 years! The first "B" Eliminator ever offered at a reasonable price which combines high power output with real long life. Delivers every voltage required by the modern multi-tube set, 5-8-10 tubes—it makes no difference. Plenty of pure, smooth, hum-free power for any set. And we let you try it free before you buy.

A Real High Quality Lifetime "B"—at a Price that Stagger Comparison

Do not confuse this new, advanced type "B" unit, with chemical rectifier types or with cheap eliminators having only a single filter choke or employing short lived single paper filter condensers. The Cloverleaf Lifetime "B" is all that its name implies. It is the true lifetime unit; good for long years of dependable service, even under heavy load. Only the very finest quality materials go into the Cloverleaf Lifetime "B"—twooversize filter chokes—the very finest grade high voltage heavy duty filter condensers that money can buy—the best, longest lived, newest type of thoroughly dependable wire-wound voltage control resistances that experts could design. Every part, every bit of workmanship is the best. Yet, the Cloverleaf Lifetime, high voltage "B" costs only half what others of equal capability cost you.

ONLY 1/2 THE PRICE OF OTHERS

Operates "171" and "210" Power Tubes

Many "B" eliminators costing more than the Cloverleaf will test at 180 volts on a meter. But what YOU must have is high voltage under load. The Cloverleaf Lifetime "B" provides plenty of voltage and plenty of current for all the ordinary demands of the set—then it supplies ample voltage for the proper operation of either a "171" or a "210" power tube.

Heretofore you have had to pay a really exorbitant price for an eliminator that would do what the Cloverleaf does. Read our FREE TRIAL OFFER. Then send the coupon.

Get Ready for WINTER

FREE TRIAL GUARANTEE OFFER and 2 YEAR GUARANTEE

CLIP AND MAIL AT ONCE!

Users Anxious to Spread Praise for this Great, New, Better Eliminator

"I purchased a Cloverleaf "B" eliminator from you on the strength of the wonderful performance of your other product—Subantenna. The Cloverleaf "B" is, in every sense of the word, all you claim for it. I have it hooked up to an eight tube set. It not only operates the set in beautiful style but also operates my power amplifier which has two Western Electric power tubes in it. No "B" eliminator ever made my set perform like the Cloverleaf does."—L. M. P., Chicago.

"I have tried several "B" battery eliminators on my superheterodyne but they all caused 'motor-boating.' The Cloverleaf works perfectly. No 'hubbub' sounds, and no hum. I am well satisfied."—W. J. S., Cadott, Wis.

"The Cloverleaf "B" received and it works fine. Other eliminators all failed when the A. C. line voltage fluctuated. The knob on the front of the Cloverleaf certainly takes care of that condition nicely.

"Several of my friends have seen the Cloverleaf at my house and said they were going to order eliminators for their sets. I gave them your name and address." F. E., Watervliet, Mich.

Made by the makers of Subantenna

the underground antenna whose remarkable performance has placed the Cloverleaf Mfg. Company in the enviable position of being known as makers of reliable radio apparatus

Cloverleaf "B" ELIMINATOR

Cloverleaf Manufacturing Company
2712-F Canal Street • • • • • Chicago, Ill.

Guaranteed 2 YEARS

TRY IT FREE

Users Anxious to Spread Praise for this Great, New, Better Eliminator

"I purchased a Cloverleaf "B" eliminator from you on the strength of the wonderful performance of your other product—Subantenna. The Cloverleaf "B" is, in every sense of the word, all you claim for it. I have it hooked up to an eight tube set. It not only operates the set in beautiful style but also operates my power amplifier which has two Western Electric power tubes in it. No "B" eliminator ever made my set perform like the Cloverleaf does."—L. M. P., Chicago.

"I have tried several "B" battery eliminators on my superheterodyne but they all caused 'motor-boating.' The Cloverleaf works perfectly. No 'hubbub' sounds, and no hum. I am well satisfied."—W. J. S., Cadott, Wis.

"The Cloverleaf "B" received and it works fine. Other eliminators all failed when the A. C. line voltage fluctuated. The knob on the front of the Cloverleaf certainly takes care of that condition nicely.

"Several of my friends have seen the Cloverleaf at my house and said they were going to order eliminators for their sets. I gave them your name and address." F. E., Watervliet, Mich.

ONLY 1/2 THE PRICE OF OTHERS

Operates "171" and "210" Power Tubes

Many "B" eliminators costing more than the Cloverleaf will test at 180 volts on a meter. But what YOU must have is high voltage under load. The Cloverleaf Lifetime "B" provides plenty of voltage and plenty of current for all the ordinary demands of the set—then it supplies ample voltage for the proper operation of either a "171" or a "210" power tube.

Heretofore you have had to pay a really exorbitant price for an eliminator that would do what the Cloverleaf does. Read our FREE TRIAL OFFER. Then send the coupon.

Get Ready for WINTER

FREE TRIAL GUARANTEE OFFER and 2 YEAR GUARANTEE

CLIP AND MAIL AT ONCE!

Guaranteed 2 YEARS

TRY IT FREE

Users Anxious to Spread Praise for this Great, New, Better Eliminator

"I purchased a Cloverleaf "B" eliminator from you on the strength of the wonderful performance of your other product—Subantenna. The Cloverleaf "B" is, in every sense of the word, all you claim for it. I have it hooked up to an eight tube set. It not only operates the set in beautiful style but also operates my power amplifier which has two Western Electric power tubes in it. No "B" eliminator ever made my set perform like the Cloverleaf does."—L. M. P., Chicago.

"I have tried several "B" battery eliminators on my superheterodyne but they all caused 'motor-boating.' The Cloverleaf works perfectly. No 'hubbub' sounds, and no hum. I am well satisfied."—W. J. S., Cadott, Wis.

"The Cloverleaf "B" received and it works fine. Other eliminators all failed when the A. C. line voltage fluctuated. The knob on the front of the Cloverleaf certainly takes care of that condition nicely.

"Several of my friends have seen the Cloverleaf at my house and said they were going to order eliminators for their sets. I gave them your name and address." F. E., Watervliet, Mich.

ONLY 1/2 THE PRICE OF OTHERS

Operates "171" and "210" Power Tubes

Many "B" eliminators costing more than the Cloverleaf will test at 180 volts on a meter. But what YOU must have is high voltage under load. The Cloverleaf Lifetime "B" provides plenty of voltage and plenty of current for all the ordinary demands of the set—then it supplies ample voltage for the proper operation of either a "171" or a "210" power tube.

Heretofore you have had to pay a really exorbitant price for an eliminator that would do what the Cloverleaf does. Read our FREE TRIAL OFFER. Then send the coupon.

Get Ready for WINTER

FREE TRIAL GUARANTEE OFFER and 2 YEAR GUARANTEE

CLIP AND MAIL AT ONCE!

CLOVERLEAF MFG. CO.
2712-F Canal St., Chicago, Ill.

Tell me more about the Cloverleaf "B" Eliminator and particulars of your FREE TRIAL OFFER.

Name.....

Town.....

State.....

WEBH Chicago, Ill. (365.6m-820kc) 7-8 p. m. WEA; 9, orchestra; 10:15, orchestra.
 WENR Chicago, Ill. (288.3m-1040kc) 8, orchestra, artists; 9:30, popular program.
 WFAA Dallas, Tex. (499.7m-600kc) 6:30 p. m. music; 8:30-9:30, music.
 WFLA Clearwater, Fla. (365.6m-820kc) 8:30 p. m. program; 9:45, dance program.
 WGN Chicago, Ill. (305.9m-980kc) 6:10 p. m. Punch and Judy; 6:50, old fashioned almanack; 8, WEA; 10, Sam 'n' Henry; 10:10, Music Box; 10:20, songs, Correll and Coates; 10:52, songs.
 WHAS Louisville, Ky. (461.3m-650kc) 7:30 p. m. WEA; 8, studio concert.
 WHB Kansas City, Mo. (336.9m-890kc) 7 p. m. dinner hour organ; 8, evening concert.
 WHO Des Moines, Ia. (535.4m-560kc) 6:30 p. m. dinner concert; 8:30, classical music; 9, drama.
 WIT Chicago, Ill. (416.4m-720kc) 7-10 p. m., 11-1.
 WIBO Chicago, Ill. (416.4m-720kc) 6:15-7 p. m., 10-11.
 WJAZ Chicago, Ill. (263m-1140kc) 9:30 p. m. studio program.
 WJJD Chicago, Ill. (365.6m-820kc) 8-9 p. m. children hour; 11-12, Victoriana.
 WLAC Nashville, Tenn. (226m-1330kc) 9 p. m. program; 10-11, orchestra.
 WLIB Chicago, Ill. (305.9m-980kc) 7 p. m. ensemble; 11-1 a. m. organ.
 WLS Chicago, Ill. (344.6m-870kc) 7:30 p. m. Super-tone hour.
 WMAQ Chicago, Ill. (447.5m-670kc) 8, orchestra; 9, program; 10, Chicago theater.
 WOAI San Antonio, Tex. (302.8m-990kc) 8:30-9:30, R. C. A. hour.
 WOC Davenport, Ia. (374.8m-800kc) 8 p. m. WEA; 9, music.
 WOW Omaha, Nebr. (508.2m-590kc) 6:30 p. m. fretted instruments, Francis Fottler; 9, classical.
 WQJ Chicago, Ill. (447.5m-670kc) 11:30 p. m. orchestra.
 WSB Atlanta, Ga. (475.9m-630kc) 8 p. m. music; 10:45, organ.
 WSBC Chicago, Ill. (232.4m-1290kc) 5-7 p. m., artists; 9-11, program.
 WSM Nashville, Tenn. (340.7m-880kc) 7:15 p. m. program; 8, studio program; 9, pipe organ.
 WSMB New Orleans, La. (322.4m-930kc) 8:30-10:30 p. m. program.
 WTMJ Milwaukee, Wis. (293.9m-1020kc) 7:30 p. m. WJZ; 8:30, program; 9:30-12, frolic.
Pacific Standard Time Stations
 KFI Los Angeles, Calif. (468.5m-640kc) 7 p. m. old-timers' program; 8, drama hour; 8:30, program; 9, orange network; 10, music.
 KFI Seattle, Wash. (447.5m-670kc) 7:30-8, program; 9-10, chain program.
 KFVB Hollywood, Calif. (361.2m-830kc) 6-7 p. m. dinner concert; 7:50, news; 8-9, features; 9-10, program; 10-11, frolics.
 KGO Oakland, Calif. (384.4m-780kc) 6-6:55 p. m. Stanislas Bem's Little symphony; 8, drama hour; 9-10, orange network; 10, orchestra.
 KGW Portland, Ore. (491.5m-610kc) 6-7 p. m. dinner concert; 7:45-8, lecture; 8-9, vaudeville; 9-12, National Broadcasting company; 10-12, dance band.
 KHJ Los Angeles, Calif. (405.2m-740kc) 6:30-7:30 p. m. children's hour; 8-10, string quartet, 10-11, Variety Four.
 KJR Seattle, Wash. (348.6m-860kc) 6:30 p. m. dinner hour; 8-10, studio program.
 KNX Hollywood, Calif. (336.9m-890kc) 7 p. m. records; 8, program; 9-10, features; 11, Hotel Ambassador.
 KPO San Francisco, Calif. (422.3m-710kc) 6:30-7 p. m. State Restaurant orchestra; 7-7:30, Rudy Seiger's Fairmont hotel concert orchestra; 8-9, program; 9-10, music; 10-11, music.
 Thursday, silent night for: KFAB, KLX, KOA, WDDO, WEAQ, WEMC, WLIT, WOO, WOS, WOW.

FRIDAY, OCTOBER 7
Headliners

Eastern 6 p.m.	Central 4	Mountain 5	Pacific 3
WJZ (508.2m-590kc) Brown University band and orchestra.	6	5	4
WCCO (405.2m-740kc) Officer Mulcahey and Mike. WIC (535.4m-560kc) "What to Do in the Flower Garden in the Fall," R. H. Patch.	6	5	4
KMA (394.5m-760kc) Jubilee Singers. WGY (379.5m-790kc) "Fro-Joy Hour."	8:30	7:30	5:30
WFLA (365.6m-820kc) Organ and artists recital. WHAS (461.3m-650kc) Reister orchestra, direction of Will J. Nicholson.	8:30	7:30	5:30
WGY (379.5m-790kc) WGY players. WOR, Newark, N. J.	9	7	6
WOR (422.3m-710kc) WEAN (319m-940kc). WNAC (352.7m-850kc) WFBI (258.5m-1160kc). WMAK (545.1m-550kc) WCAU (277.6m-1080kc). WJAS (270.1m-1110kc), WADC (296.9m-1010kc). WAIU (282.8m-1060kc), WKRC (333.1m-900kc). WGHP (319m-940kc), WMAQ (447.5m-670kc). KOIL (277.6m-1080kc), KMOX (299.8m-1000kc). WQWO (228.9m-1310kc), WCAO (384.4m-780kc). Columbia chain.	9:30	8:30	6:30
WFAA (499.7m-600kc) William S. Lemly, Jr., tenor.	9:30	8:30	6:30
WHO (535.4m-550kc) Radio's youngest baritone. WRVA (254.1m-1180kc) Edgeworth Party night.	9:35	8:35	6:35
WGHE (236.1m-1270) Troubadours.	10	9	7
WR (422.3m-710kc), WEAN (319m-940kc), WNAC (352.7m-850kc) WFBI (258.5m-1160kc), WMAK (545.1m-550kc), WCAU (277.6m-1080kc), WJAS (270.1m-1110kc), WADC (296.9m-1010kc), WAIU (282.8m-1060kc), WKRC (333.1m-900kc), WGHP (319m-940kc), WMAQ (447.5m-670kc), KOIL (277.6m-1080kc), KMOX (299.8m-1000kc), WQWO (228.9m-1310kc), WCAO (384.4m-780kc), Columbia chain.	10:30	9:30	7:30
WCAE (499.7m-600kc) William S. Lemly, Jr., tenor.	10:30	9:30	7:30
WLS (344.6m-870kc) Little Symphony "Pop" concert.	10:30	9:30	7:30
KEI (468.5m-640kc) Welsh Male Voice glee singers.	11	9	8
WIBO (416.4m-720kc) Luella Feiertag, concert coloratura soprano.	11:15 a.m.	12:15	10:15
WBBM (389.4m-770kc) Organ club.			

Regular Friday Features
Eastern Time Stations

KDKA Pittsburgh, Pa. (315.6m-950kc) 8, WJZ; 8:30, WJZ; 11:30, dance program.
 WBAL Baltimore, Md. (285.5m-1050kc) 7:30-8 p. m. recital; 8-9, ensemble; 9, dance orchestra.
 WBZ Springfield, Mass. (333.1m-900kc) 6:15 p. m. orchestra; 7:30, time; 8:30, WJZ; 9, WJZ; 10, orchestra.
 WCAE Pittsburgh, Pa. (516.9m-580kc) 6 p. m. dinner concert; 8, WEA; 10, program; 11, orchestra; 12, night club.
 WCAU Philadelphia, Pa. (336.9m-890kc) 7 p. m. orchestra; 10, Architects; 11, orchestra.
 WCHS Portland, Me. (361.2m-830kc) 8 p. m. Treasure Hunters.
 WEA New York, N. Y. (491.5m-610kc) 9, Musical Miniatures, WTAG, WLIT, WRC, KSD, WOC, WTC; 9:30, La France orchestra, WGR, WLIT, WCAE, WTAM, WWJ, KSD, WOC, WDAF, WEA; 10, Whittall Anglo-Persians, WEEB, WJAR, WTAG, WGR, WLIT, WRC, WCAE, WTAM, WWJ, WGN, KSD, WOC, WCCO, WDAF, WGY; 11, orchestra.
 WEEI Boston, Mass. (447.5m-670kc) 7:30 p. m. Merry Milkmen; 8, WEA; 9, Neapolitan Dutch Girls; 9:50, music; 10, cruising the air; 10:10, news; 10:15, organ.
 WFLA Clearwater, Fla. (365.6m-820kc) 8:30 p. m. organ and artists; 9:45, dance program.
 WGBS New York, N. Y. (348.6m-860kc) 6:30-7 p. m. orchestra.
 WGR Buffalo, N. Y. (302.8m-990kc) 6:30-7:30 p. m. dance orchestra; 8-11:30, WEA.
 WGY Schenectady, N. Y. (379.5m-790kc) 7:30 p. m. dinner music; 8:30, WEA; 11, dance program.
 WHAR Atlantic City, N. J. (272.6m-1100kc) 7:45 p. m., sport talk; 8, evening concert.

WHK Cleveland, Ohio (265.3m-1130kc) 6:30 p. m. program; 10, program; 11:01, dance music.
 WIP Philadelphia, Pa. (508.2m-590kc) 7 p. m. bedtime story.
 WJAX Jacksonville, Fla. (336.9m-890kc) 8 p. m. popular program.
 WJR-WCX Detroit, Mich. (440.9m-680kc) 8 p. m., WJZ; 8:30, WJZ; 11, dance music.
 WJZ New York, N. Y. (454.2m-660kc) 8:30, Royal Stenographers, WBZ, KDKA, KYW, WBAL, WJR; 9, Philco hour, WBZ, KDKA, KYW, WHAS, WSB, WMC, WSM, WBTC, WBAL, WJAM, WOC, WOW, WHO, WJR, KSD, WCCO, WLW, WTMJ; 10, time, WBZ, KDKA, KYW; 10, Around the piano; 10:30, orchestra, WRC.
 WLIT Philadelphia, Pa. (405.2m-740kc) 8 p. m. WEA; 9:30, WEA; 11, orchestra.
 WMAK Buffalo, N. Y. (545.1m-550kc) 6:30 p. m. dinner music; 7:15, news; 9:30, music; 10:30, studio program.
 WMCA New York, N. Y. (370.2m-810kc) 6:30 p. m. orchestra; 10, music; 11, Parody club.
 WOO Philadelphia, Pa. (508.2m-590kc) 7:30 p. m. WOO trio; 8:30, organ; 9, modern program.
 WOR Newark, N. J. (422.3m-710kc) 6:15 p. m. songs; 9, Columbia chain; 11, orchestra.
 WTAG Worcester, Mass. (516.9m-580kc) 8:30 p. m. music; 9, WEA; 9:30, music; 10:30, news.
 WTAM Cleveland, Ohio (399.8m-750kc) 6 p. m. orchestra; 7, WEA; 8, program; 11, orchestra.
 WTC Hartford, Conn. (535.4m-560kc) 7 p. m., talk; 8-9:30, WEA; 9:30, music; 11, orchestra.
 WRC Washington, D. C. (468.5m-640kc) 6, WEA; 8, WEA; 9, Lord Calvert ensemble; 9:30, WEA; 10:30, WEA.
 WRVA Richmond, Va. (254.7m-1180kc) 7 p. m. program.
 WSAI Cincinnati, Ohio (361.2m-830kc) 7 p. m. WEA; 8, time.
 WSEA Norfolk, Va. (263m-1140kc) 7 p. m. dinner concert; 9, orchestra; 10, Colonial night club.
 WWJ Detroit, Mich. (352.7m-850kc) 6 p. m. concert; 8, WEA; 9, music; 8-11:30, WEA.

Central Time Stations
 KFAB Lincoln, Nebr. (309.1m-970kc) 5:30-6:30 p. m. Hotel Lincoln orchestra; 8:30-10, program; 11-1, frolic.
 KMA Shenandoah, Ia. (394.5m-760kc) 6 p. m. music; 7, popular; 8, dance orchestra.
 KSD St. Louis, Mo. (545.1m-550kc) 6 p. m. WEA; 8:30, dance music; 11, orchestra.
 KTHS Hot Springs National Park, Ark. (384.4m-780kc) 8:30-9:30 p. m. novelties; 9:30-10:15, orchestra.
 KYW Chicago, Ill. (526m-570kc) 7-10:30 p. m. program; 10:30-11:55, music.
 WBAP Ft. Worth, Tex. (499.7m-600kc) 7:30-8:30, music; 9:30-12, concert.
 WBBM Chicago, Ill. (389.4m-770kc) 7-11 p. m. music; 12, organ.
 WBCN Chicago, Ill. (283.3m-1040kc) 7 p. m. popular program.
 WCCO Minneapolis-St. Paul, Minn. (405.2m-740kc) 7 p. m. WEA; 9, WEA; 10:05, dance orchestra.
 WCFL Chicago, Ill. (483.6m-620kc) 6 p. m. labor hour; 7, trio; 10:15-12 mid., stage show.
 WCOA Pensacola, Fla. (249.9m-1200kc) 8 p. m. program.
 WDAF Kansas City, Mo. (370.2m-810kc) 7 p. m. WEA; 8, program; 8:30, WEA; 9, WEA; 11:45-1 a. m. Nighthawk frolic.
 WDDO Chattanooga, Tenn. (245.8m-1220kc) 7-10 p. m., music.
 WEBH Chicago, Ill. (365.6m-820kc) 7-8 p. m. artists; 8:30, WEA; 9, orchestra.
 WENR Chicago, Ill. (288.3m-1040kc) 6 p. m. organ; 8, classical program; 9:30, studio program.
 WFAA Dallas, Tex. (499.7m-600kc) 6-7 p. m. WEA; 7, music; 8:30, program.
 WGN Chicago, Ill. (305.9m-980kc) 6:50 p. m. Old Fashioned almanack; 8:30, Paul Ash; 9:30, burlesque; 10, Sam 'n' Henry; 10:10, Music Box; 10:20, songs, Tommy Coates; 10:40, Pepper Party.
 WHAS Louisville, Ky. (461.3m-650kc) 7 p. m. studio concert; 8, WEA.
 WHB Kansas City, Mo. (336.9m-890kc) 7-8 p. m. talk.
 WHO Des Moines, Ia. (535.4m-560kc) 6:30 p. m. orchestra; 8:30, string trio.

Now!
TELEVOCAL
TUBES
 for A. C. Sets

Electrify your set with the new Televocal T. C. 226 and T. C. 227 Tubes. Using these tubes you can operate on A. C. current without "A" Batteries. Thoroughly tested; genuine Televocal quality; guaranteed.

Also use Televocal T. C. 112 and T. C. 171 Power Tubes. Now made with oxide coated filament, current consumption is reduced 1/2-1 from 1/2 to 1/4 amperes.

Televocal Tubes are made in all standard types.

Televocal Corp.
 Televocal Building
 Dept. D-1, 588 12th St.,
 West New York, N. J.

TELEVOCAL
QUALITY
TUBES

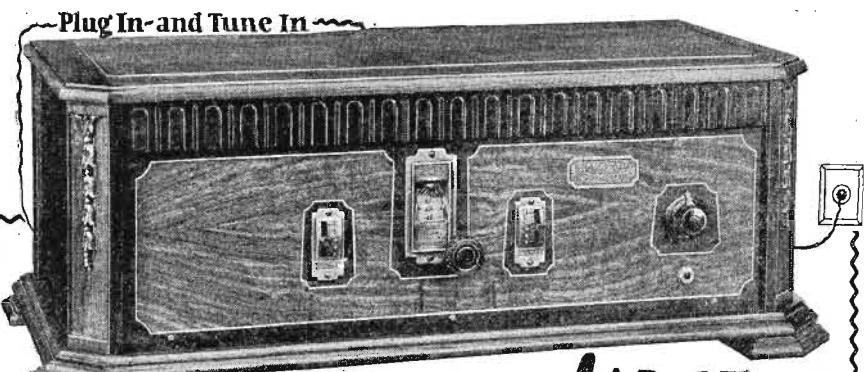

Plug In—and Tune In

Now! A Real Electric Radio Set
Three Year Guarantee
No Batteries, Chargers or Eliminators
No Acids; No Liquids—Plug In—Press Button—"Tune In"

Shipped direct from our factory at rock bottom prices—cost less than most battery sets

Metrodyne
ALL ELECTRIC RADIO

7 Tubes—Single Dial Set

100% Electric Radio

At last! The radio you've dreamed about! If you have electricity in your home you can now really enjoy coast to coast radio reception without the care, bother and muss of batteries, chargers, eliminators, etc. The Metrodyne All Electric is a real, genuine batteryless radio set. Simply insert the plug in the socket, press the switch button and "tune in." You could not possibly buy a better radio set than the Metrodyne All Electric, no matter what price you paid.

AGENTS! DEALERS! BIG PROFITS!

Make big money taking orders for Metrodynes. All or part time. Metrodyne All Electric Radios are in a class by themselves. Unequaled for quality, performance and price. Demonstrate at home and take orders. Lowest wholesale prices. Your demonstrating set on 30 days' free trial. Mail coupon below for details.

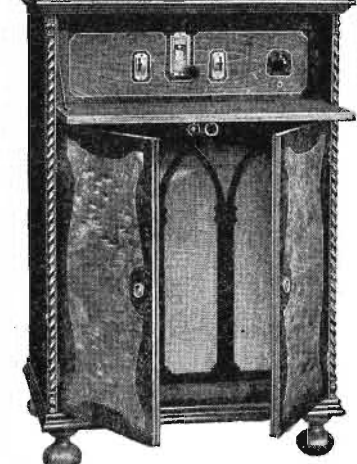

Gorgeous Console Electric Radio

Here is the Metrodyne All Electric Console Radio—a gorgeous, genuine walnut cabinet, in a beautiful two-tone finish. Has a built-in genuine Metrodyne large size speaker. Brings in programs with great volume, reproducing the entire range from the lowest to the highest notes with remarkable clearness and distinction. All metal parts are finished in old gold. Wonderful electric radio, in a cabinet that will beautify the appearance of any home.

Beauty—Efficiency Dependability

The Metrodyne All Electric Radio is a 7-tube, single dial set. Only the highest quality low loss parts are used throughout. Solid walnut cabinet, beautiful two-tone effect, with handsome gilt metal trimmings. Size of cabinet, 28 inches long, 13 inches deep, 10 inches high. Has electrically lighted dial so that you can log stations in the dark. Only one dial to tune in all stations. Excellent tone qualities—wonderful volume—very selective.

Costs Less Than Most Battery Sets

Do not confuse the Metrodyne electric radio with ordinary light socket sets, because the Metrodyne is truly an all electric radio—consumes less than 2c worth of power a day. Comes to you direct from the factory. Its low cost brings it down to the price of an ordinary battery set. We are so confident that you will be delighted with this wonderful, easy-to-operate batteryless radio that we offer to ship it to your home for thirty days' free trial—you to be the judge.

Mail Coupon Below We are one of the pioneers of radio. The success of Metrodyne sets is due to our liberal 30 days' free trial offer, which gives you the opportunity of trying before buying. Thousands of Metrodynes have been bought on our liberal free trial basis. **WRITE TODAY!** Send a postal, letter or mail coupon.

METRO ELECTRIC COMPANY
2165 N. California Ave., Dept. 647, Chicago, Illinois

METRO ELECTRIC COMPANY
2165 N. California Ave., Dept. 647
Chicago, Illinois

Send me full particulars about Metrodyne All Electric Radio and your **THIRTY DAYS' FREE TRIAL OFFER.**

Name _____

Address _____

If you are interested in AGENT'S proposition place an "X" in the square

WHT Chicago, Ill. (416.4m-720kc) 7-10 p. m. program; 10-1, frolic.

WIBO Chicago, Ill. (416.4m-720kc) 6-7 p. m. song recital; 10-1, frolic.

WJAZ Chicago, Ill. (263m-1140kc) 7 p. m. dinner concert; 9, studio program.

WJJD Chicago, Ill. (365.6m-820kc) 8-8:30 p. m. musical hour; 11-11.30, Victrolans.

WLIB Chicago, Ill. (305.9m-890kc) 7 p. m. WEAF.

WLS Chicago, Ill. (344.6m-870kc) 7:20 p. m. Duo; 10, Showcat; 11-12, popular.

WMAQ Chicago, Ill. (447.5m-670kc) 6 p. m. chimes; 8, Columbia chain; 12, popular program.

WQJ Chicago, Ill. (447.5m-670kc) 10 p. m. orchestra.

WQAI San Antonio, Tex. (302.8m-890kc) 8:30 p. m. program.

WOC Davenport, Ia. (374.8m-800kc) 7 p. m. WEAF; 8, WEAF; 9:30, studio program.

WOW Omaha, Neb. (508.2m-590kc) 6 p. m. Hugo Heyn, marimba; Emil Hofmann, pianist; 9, classical; 10, Ortho-sonic hour.

WSB Atlanta, Ga. (475.9m-630kc) 8 p. m. program; 10:45, concert.

WSBC Chicago, Ill. (232.4m-1290kc) 6-8 p. m. Hugh Swift and his Serenaders; dinner concert; 9-1, popular program.

WSM Nashville, Tenn. (340.7m-860kc) 8 p. m. WEAF.

WTMJ Milwaukee, Wis. (293.9m-1020kc) 7 p. m. classical program; 8:45, to be announced; 9:30, piano.

Mountain Standard Time Stations
KOA Denver, Colo. (325.9m-920kc) 7:30 p. m. S. S. Lesson; 8, flying lessons; 8:15, program.
KOB State College, N. M. (394.4m-760kc) 7:30 p. m. orchestra.

Pacific Standard Time Stations
KFI Los Angeles, Calif. (468.5m-640kc) 7 p. m. organ; 8, program; 9, orange network; 10, musicale.
KFOA Seattle, Wash. (447.5m-670kc) 9-10, chain program; 10:30-12, KGW.
KFWB Hollywood, Calif. (361.2m-830kc) 7 p. m. orchestra; 7:50, New York program.
KGO Oakland, Calif. (384.4m-780kc) 6-6:55 p. m. Stanislas Bem's Little symphony; 8-9, feature; 9-10, National Broadcasting company orchestra; 10, orchestra; 11, orchestra.
KGW Portland, Ore. (491.5m-610kc) 6-7 p. m. dinner concert; 8-9, concert; 9, National Broadcasting company; 10, Jubilee players; 10:30, Hoot Owls. KMO, KFOA, KHO.
KHJ Los Angeles, Calif. (405.2m-740kc) 6:30-7:30, children's hour; 8-10, popular program; 9, talks.
KJR Seattle, Wash. (348.6m-860kc) 6:30 p. m. dinner hour; 8-10, program.
KLX Oakland, Calif. (508.2m-590kc) 8 p. m. special program; 9:30-10:30, Athens Athletic club orchestra.
KNX Hollywood, Calif. (336.9m-890kc) 7 p. m. feature; 8, 9, 10, features; 11, Hotel Ambassador.
KPO San Francisco, Calif. (422.3m-710kc) 6:30 p. m. States Restaurant orchestra; 8-9, orchestra; 9, organ; 10-11, orchestra.

Friday, silent night for: KPRC, KPSN, WCBD, WFL, WIP, WLAC, WLIT, WLW, WPG, WSM, WSMB.

SATURDAY, OCTOBER 8
Headliners

Eastern	Central	Mountain	Pacific
8:30 p. m.	7:30	6:30	5:30
WIAS (461.3m-650kc) Kentucky Hotel orchestra, direction of Signor Paolo Grosso.			
9	6		
KMA (394.5-760kc) Harness Makers, community singing.			
WIP (508.2m-590kc) Lansdowne Salon orchestra.	8:30	7:30	6:30
9:30	8:30	7:30	6:30
KTHS (384.4m-780kc) Mrs. George Fletcher, soprano.			
10:30	9:30	8:30	7:30
WDAF (370.2m-810kc) Great Western Chefs.			
11	10	9	8
KGW (384.4m-780kc), KFI (468.5m-640kc), KPO (422.3m-710kc), KGW (491.5m-610kc), KOMO (305.9m-890kc) Saturday night revue.			
11:45	10:45	9:45	8:45
WSB (475.9m-630kc) Charlie Troutt's Melody Artists.			
12 mid.	11	10	9
WLS (344.6m-870kc) Show broadcast from White City studio.			
12:30 a. m.	11:30	10:30	9:30
WFAA (499.7m-600kc) Organ, piano, and feature performers from Palace Theatre bill.			
1	12	11	10
WBBM (389.4m-770kc) Midnite Jambouree.			

For Regular Features See Saturday, October 1.

Football

Arkansas-Baylor at Fayetteville, KUOA (296.9m-1010kc).

Butler-Illinois at Urbana, WRM (272.6m-1100kc), California-St. Mary's at Berkeley, KPO (422.3m-710kc).

Indiana-Chicago at Chicago, KYW (526m-570kc), WGN (305.9m-890kc), WMAQ (447.5m-670kc), WMBB (252m-1190kc).

Iowa State-Simpson College at Ames, WOI (265.3m-1130kc).

Minnesota-Ola, Aggies at Minneapolis, WAMD (225.4m-1330kc).

Northwestern-Utah at Evanston, WEBB (365.6m-820kc), WIBO (416.4m-720kc).

Ohio-Iowa at Iowa City, WEAO (282.8m-1060kc), WSUI (422.3m-710kc).

Oregon-Aggies-U. S. S., KFI (468.5m-640kc).

6 TUBE SUPERPHONIC RADIO KIT COMPLETE

All Metal Chassis Shielded

Only \$16.95

Can be built in 2 hours

COAST TO COAST RECEPTION

Latest 6 tube tuned radio frequency circuit. Extremely selective, marvelous sensitivity. 2 stages of radio frequency, detector and 3 audio amplifiers for improved tone quality. 2 dial control. All metal chassis. Shielded. Clear and realistic reception guaranteed. Beautiful ornamental design on front panel, crystalline finish. Metal panel and sub panel; all holes drilled making mounting of parts very simple. No special tools needed. Vernier dials for fine tuning. New type UX sockets. All hook-up wire and colored battery cable included. Value \$60.00, our price, \$16.95.

Complete Set of Simple Plans and Directions to Build

Very easy to build this set with the plans and instruction we furnish. No complicated drawings. Can be built in two hours. Instruction for operation also included. Make money by building these sets in your spare time and selling them to your friends.



SEND NO MONEY

Just write your name and address on a post card and ask us to send you this great kit together with 6 tubes. We will ship them right away. When they arrive, pay only \$16.95 plus a small delivery charge.

RADIO EQUIPMENT CO.

Dept. D. 549 S. Wells St., CHICAGO, ILL.

SUNDAY, OCTOBER 9
Headliners

Eastern	Central	Mountain	Pacific
4:30 p. m.	3:30	2:30	1:30
WIBO (416.4m-720kc) Music That Never Grows Old.			
5:30	4:30	3:30	2:30
WTIC (535.4m-560kc) Travelers symphonic ensemble.			
7	6	5	4
WLS (344.6m-870kc) WLS Little Brown Church.	9:15	8:15	7:15
9:15	8:15	7:15	6:15
WEAF (491.5m-610kc), WEEI (447.5m-670kc), WGR (302.8m-890kc), WRC (468.5m-640kc), WCAE (516.9m-380kc), WWJ (352.7m-850kc), WSAI (361.2m-830kc), WGN (305.9m-890kc), KSD (545.1m-550kc), WOC (374.8m-800kc), WCCO (405.2m-740kc), WGY (379.5m-790kc) Margaret Matzenauer, contralto.			
9:30	8:30	7:30	6:30
KTHS (384.4m-780kc) Music Lovers Hour.			
10	9	8	7
WMBB (252m-1190kc) Jean and Joan.			
11	10	9	8
KGO (384.4m-780kc), KFI (468.5m-640kc), KGW (491.5m-610kc) Great Moments in History.			
12 mid.	11	10	9
WFAA (499.7m-600kc) Dick Richardson's Dallas Country Club orchestra.			
1 a. m.	12	11	10
WBBM (389.4m-770kc) Nutty Club.			

For Regular Features See Sunday, October 2.

MONDAY, OCTOBER 10
Headliners

Eastern	Central	Mountain	Pacific
7 p. m.	6	5	4
WTIC (535.4m-560kc) Trinity Dialog.			
8 p. m.	7	6	5
KMA (394.5m-760kc) Gray Sisters, classical program.			

Eastern	Central	Mountain	Pacific
8 p. m.	7	6	5
WFAA (499.7m-600kc) State Fair program from the Fair Grounds.			
9:30	8:30	7:30	6:30
KTHS (384.4m-780kc) W. C. Brown, baritone.			
WEAF (491.5m-610kc), WJAR (483.6m-620kc), WTIC (535.4m-560kc), WCAE (516.9m-380kc), WWSJ (352.7m-850kc), WWSJ (574.8m-800kc) opera "La Traviata."			
9:10	8:10	7:10	6:10
WRVA (254.1m-1180kc) J. Harold Lawrence's orchestra.			
10:15	9:15	8:15	7:15
KOA (325.9m-920kc) "Dark, Dark Secrets."			

For Regular Features See Monday, October 3.

TUESDAY, OCTOBER 11
Headliners

Eastern	Central	Mountain	Pacific
7:30 p. m.	6:30	5:30	4:30
WCCO (405.2m-740kc) "F and R Family," 4:30			
WGYP (379.5m-790kc) outdoor talk, Jud Landon.			
7:45	6:45	5:45	4:45
WIBO (416.4m-720kc) "Deep Sea Ballads," Edward Zander, Jr.			
8	7	6	5
KMA (394.5m-760kc) Applesauce Twins.			
WFAA (499.7m-600kc) State Fair program from State Fair Grounds.			
WMBB (252m-1190kc) Doris Mason Moran; Trianon mixed quartet.			
8:30 p. m.	7:30	6:30	5:30
WLS (344.6m-870kc) Don Malin, "Personalities in Music"—Chopin.			
9	8	7	6
KTHS (384.4m-780kc) Lon Chassy, violin; John G. Heyn, piano.			

30 Days FREE TRIAL 3 Year Guarantee

MARWOOD

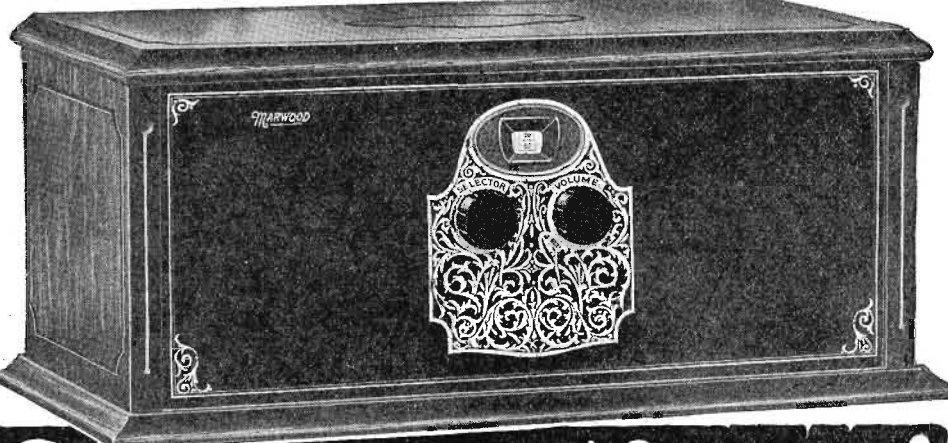

The 1928 Sensations!
8 Tube-1 Control

All Electric or Battery Operation

AGAIN Marwood is a year ahead—with the Radio sensation of 1928—at a low price that smashes Radio profiteering. Here's the sensation they're all talking about—the marvelous 8-Tube Single Control Marwood for BATTERY or ALL ELECTRIC operation. Direct from the factory for only \$69.00 retail price—a price far below that of smaller, less powerful Radios. Big discount to agents from this price. You can't beat this wonderful new Marwood and you can't touch this low price. Why pay more for less quality? To prove that Marwood can't be beat we let you use it on 30 Days' Free Trial in your own home. Test it in every way. Compare it with any Radio for tone, quality, volume, distance, selectivity, beauty. If you don't say that it is a wonder, return it to us. We take the risk.

New Exclusive Features

Do you want coast to coast with volume enough to fill a theater? Do you want amazing distance that only super-power Radios like the Marwood 8 can get? Do you want ultra-selectivity to cut out interference? Then you must test this Marwood on 30 Days' Free Trial. An amazing surprise awaits you. A flip of your finger makes it ultra-selective—or broad—just as you want it. Every Marwood is perfectly BALANCED—a real laboratory job. Its simple one drum control gets ALL the stations on the wave band with ease. A beautiful, guaranteed, super-efficient Radio in handsome walnut cabinets and consoles. A Radio really worth double our low price.

Buy From Factory—Save 1/2

Why pay profits to several middlemen? A Marwood in any retail store would cost practically three times our low direct-from-the-factory price. Our policy is highest quality plus small profit and enormous sales. You get the benefit. Marwood is a pioneer, responsible Radio, with a good reputation to guard. We insist on the best—and we charge the least. If you want next year's improvements NOW—you must get a Marwood—the Radio that's a year ahead.

AGENTS

Make Big Spare-Time Money

Get your own Radio at wholesale price. It's easy to get orders for the Marwood from your friends and neighbors. Folks buy quick when they compare Marwood quality and low prices. We want local agents and dealers in each territory to handle the enormous business created by our national advertising. Make \$100 a week or more in spare time demonstrating at home. No experience or capital needed. We show you how. This is the biggest season in Radio history. Everybody wants a Radio. Get in now. Rush coupon for 30 Days' Free Trial, beautiful Catalog, Agents' Confidential Prices and Agents' New Plan.

MARWOOD RADIO CORP.,
 5315 Ravenswood Ave.

Dept. A-4, CHICAGO, ILL.

Eastern	Central	Mountain	Pacific
8 p. m.	7	6	5
WFAA (499.7m-600kc) J. Abner Sage and other musicians.			
10:00 p. m.	9:00	8:00	7:00
WBB (336.9m-890kc) Blackface Comedians.			
WOC (352.7m-850kc) old time numbers			
10:30	9:30	8:30	7:30
WDAF (370.2m-810kc) Martin and Taylor.			
11	10	9	8
WFAA (499.7m-600kc) Seven Aces, all eleven of them.			

For Regular Features See Tuesday, October 4.

WEDNESDAY, OCTOBER 12
Headliners

Eastern	Central	Mountain	Pacific
8 p. m.	7	6	5
WMBB (252m-1190kc) Hilda Hinrichs.			
8:20	7:20	6:20	5:20
WLS (344.6m-870kc) Old Town Duo—Rose Sherman, violinist, Marie Ludwig, harpist.			
9:05	8:05	7:05	6:05
WRVA (254.1m-1180kc) Hawaiian players.			
9:30	8:30	7:30	6:30
WRVA (254.1m-1180kc) Memories of the Opera.			
10	9	8	7
WTIC (535.4m-560kc) Clements show book.			
10:15	9:15	8:15	7:15
KOA (325.9m-920kc) Henry Trustman Ginsberg, violin.			
10:30	9:30	8:30	7:30
WDAF (370.2m-810kc) Cavaliers.			
11	10	9	8
KGO (384.4m-780kc) vaudeville.			
WIBO (416.4m-720kc) Stage show, Sheridan Theatre.			

For Regular Features See Wednesday, October 5.

Only \$69 RETAIL PRICE

Big Discount to Agents From This Price

Get Our Discounts Before You Buy a Radio

Don't buy any Radio until you get our big discounts and catalog. Save half and get a Radio that IS a Radio. Try any Marwood on 30 Days' Free Trial at our risk. Tune in coast to coast on loud speaker with enormous volume, clear as a bell. Let your wife and children operate it. Compare it with any Radio, regardless of price. If you don't get the surprise of your life, return it. We take the risk. Don't let Marwood low prices lead you to believe Marwood is not the highest quality. We have smashed Radio prices. You save half.

6 Tube-1 Control

This is the Marwood 6 Tube, 1 Control for BATTERY or ALL ELECTRIC operation. Gets coast to coast on loud speaker with great volume. Only \$47.00 retail. Big discounts to Agents. Comes in handsome walnut cabinets and consoles. This low price cannot be equalled by any other high grade 6-tube Radio. Has the volume of any 7-tube set. If you want a 6-tube Radio you can't beat a Marwood and you can't touch our low price.

\$47

Retail Price
 Big Discount to Agents From This Price.

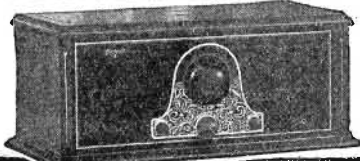

Rush for Free Trial

Marwood Radio Corporation,
 5315 Ravenswood Ave., Dept. A-4, Chicago, Ill.
 Send Agents' Confidential Prices, 30 Days' Free Trial, New Catalog and Agents' New Money Making Plan. No obligations on my part.

Name

Address

Street or R. F. D.

City State

Eastern	Central	Mountain	Pacific
10:30	9:30	8:30	7:30
KNX (336.9m-890kc) One act play.			
11:30	10:30	9:30	8:30
WCAU (336.9m-890kc) Stan Lee Broza and His Bunch.			
12 mid.	11	10	9
KOIL (277.6m-1080kc) Concert ensemble.			
WFAA (499.7m-600kc) La Mariquita and her Castilian orchestra.			
12:15 a.m.	11:15	10:15	9:15
WHB (336.9m-890kc) Rockhill Theater organ concert.			

MONDAY, OCTOBER 17
Headliners

Eastern	Central	Mountain	Pacific
7:28 p.m.	6:28	5:28	4:28
WGY (379.5m-790kc) "Footnotes," T. Arthur Cohen.			
7:45	6:45	5:45	4:45
WIBO (416.4m-720kc) Kenneth Sterling, baritone.			
9:10	8:10	7:10	6:10
WRVA (254.1m-1180kc) Singers club of Virginia.			
9:30	8:30	7:30	6:30
WGC (352.7m-850kc) Erwin Swindell, organist.			
10	9	8	7
KOA (325.9m-920kc) Scheurman's Colorado orchestra.			
KOIL (277.6m-1080kc) Shep's Barnyard Twins.			
10:10	9:10	8:10	7:10
KTHS (384.4m-780kc) Concert by Arlington Hotel orchestra.			
10:30	9:30	8:30	7:30
WCCO (405.2m-740kc) Vagabonds.			
12 mid.	11	10	9
KGO (384.4m-780kc) "Chats About New Books."			
12:45 a.m.	11:45	10:45	9:45
WDAF (370.2m-810kc) Nighthawk frolic.			

TUESDAY, OCTOBER 18
Headliners

Eastern	Central	Mountain	Pacific
7:45 p.m.	6:45	5:45	4:45
WIBO (416.4m-720kc) Charlotte Edwards, contralto.			
8	7	6	5
WLW (428m-700kc) Harmony Four.			
WMBB (252m-1190kc) Monte Blunn.			
8:30	7:30	6:30	5:30
WLS (344.6m-870kc) Don Malin, "Personalities in Music."			
9	8	7	6
WLB (336.9m-890kc) Hawaiian music.			
9:15	8:15	7:15	6:15
KTHS (384.4m-780kc) Grace Brown, the ukulele lady.			
9:30	8:30	7:30	6:30
WTIC (535.4m-560kc) Akay, Harmony Belles.			
10	9	8	7
KTHS (384.4m-780kc) Concert by Arlington Grand ensemble.			
WGN (306m-980kc) A Radio Announcer's Rambles.			
10:30	9:30	8:30	7:30
WCCO (405.2m-740kc) Trustodians.			
11	10	9	8
KGO (384.4m-780kc) Pilgrims.			

WEDNESDAY, OCTOBER 19
Headliners

Eastern	Central	Mountain	Pacific
7:15 p.m.	6:15	5:15	4:15
WIBO (416.4m-720kc) "The Constitution of the United States" talk by Clem F. Wade.			
7:45	6:45	5:45	4:45
WIBO (416.4m-720kc) Cantor Jacob H. Sonnenklar, lyric tenor; Hebrew and Italian recital.			
8	7	6	5
WLW (428m-700kc) Land O'Dance music.			

Eastern	Central	Mountain	Pacific
8	7	6	5
WMBB (252m-1190kc) Trianon mixed quartet.			
8:15	7:15	6:15	5:15
WSM (340.7m-880kc) Andrew Jackson hotel orchestra.			
9	8	7	6
WRVA (254.1m-1180kc) "A String" quartet.			
9:30	8:30	7:30	6:30
KMA (394.5m-760kc) Car-mojon Hour.			
10	9	8	7
KOA (325.9m-920kc) Tiny Town Tales.			
10:10	9:10	8:10	7:10
WTAS (461.3m-650kc) K. & I. Orchestra.			
10:30	9:30	8:30	7:30
WRVA (254.1m-1180kc) Atwater Kent Foundation contest.			
11	10	9	8
KFAB (309m-970kc) Jack and Jill.			
11:30	10:30	9:30	8:30
WGY (379.5m-790kc) WGY orchestra.			
12	11	10	9
WLS (344.6m-870kc) Choral music.			
12:30	11:30	10:30	9:30
WBBM (389.4m-770kc) Harding theater program.			
12:45	11:45	10:45	9:45
WDAF (370.2m-810kc) Cavaliers.			
1	12	11	10
WGN (306m-980kc) Somewhere in Chicagoland.			
1:30	12:30	11:30	10:30
WTIC (535.4m-560kc) Hotel Boyd orchestra.			
2	1	12	11
CPCA (357m-840kc) Canadians.			
2:30	1:30	12:30	11:30
KGO (384.4m-780kc) vaudeville.			

THURSDAY, OCTOBER 20
Headliners

Eastern	Central	Mountain	Pacific
7:45 p.m.	6:45	5:45	4:45
WGY (379.5m-790kc) Story of America.			
7:35	6:35	5:35	4:35
WGN (306m-980kc) Drake Concert ensemble.			
8	7	6	5
WMBB (252m-1190kc) Walter Levis.			
8:30	7:30	6:30	5:30
WRVA (254.1m-1180kc) Martinsville, Va., night.			
9	8	7	6
WCBU (344.6m-870kc) staff artists.			
9:30	8:30	7:30	6:30
WHAS (461.3m-650kc) Joseph J. Eisenbeis, tenor.			
9:45	8:45	7:45	6:45
WHB (336.9m-890kc) Frederick Curth players.			
10	9	8	7
KTHS (384.4m-780kc) Ross Graham, baritone.			
10:30	9:30	8:30	7:30
WLW (428m-700kc) Crosley Cossacks.			
11:30	10:30	9:30	8:30
WGY (379.5m-790kc) Floyd Walter, organist.			
12:45	11:45	10:45	9:45
WSM (340.7m-880kc) F. Arthur Henkel, organist.			
1	12	11	10
WDAF (370.2m-810kc) Nighthawk frolic.			
1:30	12:30	11:30	10:30
KGO (384.4m-780kc) Hotel St. Francis orchestra.			

FRIDAY, OCTOBER 21
Headliners

Eastern	Central	Mountain	Pacific
7:15 p.m.	6:15	5:15	4:15
WIBO (416.4m-720kc) Dwight Edrus, the Golden Voiced Tenor.			
7:30	6:30	5:30	4:30
WJR-WCX (440.9m-680kc) At Eventide.			
7:50	6:50	5:50	4:50
WTIC (535.4m-560kc) Laura C. Gaudet, pianist.			
8	7	6	5
WGN (306m-980kc) Old Fashioned Almanack.			

Eastern	Central	Mountain	Pacific
8:30	7:30	6:30	5:30
KFAB (309m-970kc) U. of Nebraska.			
8:45	7:45	6:45	5:45
WFLA (365.6m-820kc) Organ and artists recital; Mrs. Maude Sheridan, contralto.			
9	8	7	6
WRVA (254.1m-1180kc) Senor Jose Andonegui, Spanish violinist.			
9:10	8:10	7:10	6:10
KOIL (277.6m-1080kc) Old Folks at Home.			
9:30	8:30	7:30	6:30
WCCO (405.2m-740kc) Sylvester Cargill, marimba.			
9:45	8:45	7:45	6:45
WRVA (254.1m-1180kc) Ye Olde Tyme Melody Makers.			
10	9	8	7
KTHS (384.4m-780kc) Mrs. Guinn Massey, popular, piano selections.			
10:30	9:30	8:30	7:30
KOA (325.9m-920kc) Lessons in airplane flying.			
11	10	9	8
KGO (384.4m-780kc) Mme. Berthe Baret, French violinist.			

SATURDAY, OCTOBER 22
Headliners

Eastern	Central	Mountain	Pacific
8 p. m.	7	6	5
WLW (428m-700kc) Happy Harmony Boys.			
8:30	7:30	6:30	5:30
KFAB (309m-970kc) U. of Nebraska.			
9:30	8:30	7:30	6:30
KTHS (384.4m-780kc) Pete Phillips, tenor.			
10:30	9:30	8:30	7:30
WJR-WCX (440.9m-680kc) Jesters.			
11:20	10:20	9:20	8:20
WGN (306m-980kc) Music Box.			

Foot Ball

Kansas-Rolla School of Mines at Fayetteville, KUOA (296.9m-1010kc).
Chicago-Pennsylvania at Chicago, KYW (526m-570kc), WMAQ (365.6m-820kc), WMBB (252m-1190kc).
Iowa-Denver at Iowa City, WSUI (422.3m-710kc).
Minnesota-Iowa at Minneapolis, WAMD (225.4m-1330kc).
Northwestern-Illinois at Evanston, WEBH (365.6m-820kc), WIBO (416.4m-720kc).
Ohio-Michigan at Ann Arbor, WEAQ (282.8m-1060kc).
Washington-Kansas at Lawrence, KFQU (254.1m-1180kc).

SUNDAY, OCTOBER 23
Headliners

Eastern	Central	Mountain	Pacific
7 p. m.	6	5	4
WLS (344.6m-870kc) WLS Little Brown Church.			
7:30	6:30	5:30	4:30
WIBO (416.4m-720kc) Buelah Bowman, soprano; song recital.			
8	7	6	5
WMAQ (344.6m-870kc) Reverie hour.			

RADIO'S
Greatest Triumph

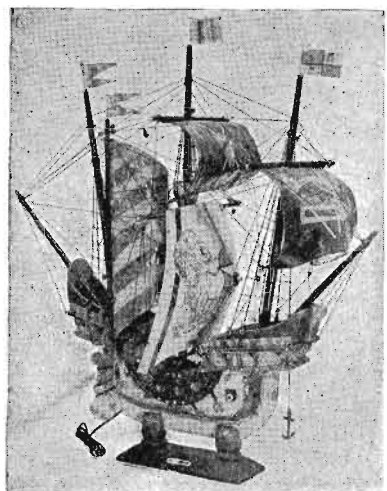

Size: 26 inches high; 12 inches wide; 27 inches long (overall)

THE MELODY SHIP

You can put these ship model loud speakers together in a few hours of pleasant pastime

You need not know anything about ship building or loud speakers to assemble one of these models. As a matter of fact, if you have never seen a ship you can put the ship model loud speaker together in a few hours by following our diagrams and instruction sheet which is so written that a school boy can understand it. All you need is a small hammer. The parts are numbered on the diagram to make the process even more simple. As long as you can understand such instructions as these (actually taken from assembling chart that is included with every model) you cannot fail: "Take No. 57, place it in front end of No. 56 and tap lightly with hammer. Next take No. 58 and place it up against No. 57 and tap with hammer to bring it into place."

Easy? Nothing simpler. The instructions are just like that from the beginning to end. Do this and that—and before you realize it a beautiful model has grown before your eyes.

The MELODY SHIP is made entirely of wood. A positive free edge cone speaker with a unit of the electro magnet type, powerful enough to operate a 72-inch cone, is attached to the mainmast. This insures splendid service and ample volume with no distortion.

The loud speaker is made in the shape of a sail and does not alter or change the appearance of the ship in any way. The sails are artistically painted with the various designs and figures of the period represented by the models.

The tone of this loud speaker is far superior to any cone of its size on the market today. This is made possible by our patented melody sail.

Write for our beautiful illustrated catalog.

Fill in the coupon below and we will attach upon it immediately.

MINIATURE SHIP MODELS, Inc.

3818-20-22-24 Baring Street
Philadelphia, Pa.

Canadian Branch:
1485 Bleury Street, Montreal, Canada

MINIATURE SHIP MODELS, INC., DEPT V.
3818-20-22-24 Baring St., Phila., Pa.

Please send me the complete parts, for the loud speaker ship model cut to fit, and ready to assemble for the La Pinta as shown above. I will pay postman \$12.50 plus postage (a few cents).

PLEASE PRINT NAME AND ADDRESS PLAINLY.

Name.....
Street or R. F. D.....
City.....
State.....

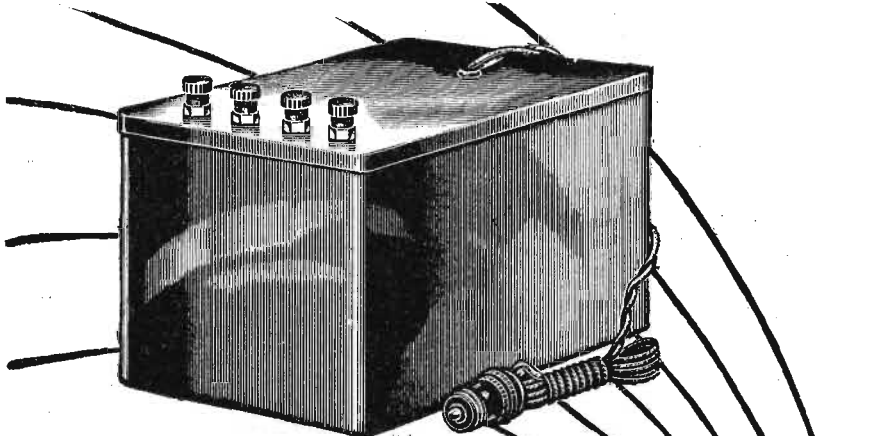

it's the Value behind the price that counts!

Because every part in the Townsend "B" Socket Power Unit is made and assembled in our own factory we can give you a high grade instrument at a surprisingly low price. Now everyone can enjoy wonderfully improved reception, uninterrupted by screeches of fading batteries.

Reports from hundreds of satisfied users prove that the Townsend "B" Socket Power is the most remarkable value in Radio today.

Money Back If Not Delighted
Sold on real guarantee of money refunded if not satisfied. Delivers up to 100 volts on any set, on D. C. or A. C.—any cycle. Full tone, clarity and volume.

Approved and passed by the rigid laboratory tests of Radio News and Popular Radio

SEND ORDER TODAY
Simply fill out the coupon and slip it into an envelope with only \$1.00 and mail at once. Your Townsend "B" Socket Power Unit will be sent promptly. Deposit only \$5.85 plus postage with the postman. Try out for 10 days—then if not amazed and delighted with improvement in reception, return it to us and purchase price will be refunded.

HERE'S YOUR PROOF

Asheville, No. Car.
Your "B" Eliminator is real good. In fact it works better than a \$65.00 Eliminator a neighbor has. Have tried them side by side.
E. V. Stewart.

Havana, N. Dak.
Please send at once one Townsend B Eliminator. Would state this is the third B Eliminator ordered from you and I have given them a very thorough trial. You will note I have returned none. I have used these Eliminator for about seven months, also having three others hooked up ranging in price from \$19 to \$35 and your make has given less trouble and as good satisfaction as any. Without doubt I will order more. You are at liberty to use this letter. I did not write it as a recommendation, simply stated the facts as I found them. I believe it is the best investment the radio fan can make.
C. L. Winn.

Raton, N. Mex.
I have been using your Eliminator every day for about four months. It has been giving perfect service. I have tried several other makes and like yours best.
Jas. D. Smith.

Ankeny, Iowa
I have been using your Eliminator for past six months on 110 volt 25 cycle current and have found results satisfactory.
Frank G. Snyder, Jr.

complete
\$6.85
\$1.00 Down
Balance
C.O.D.

Attach Only \$1.00 to this Coupon

Townsend "B"
Socket Power
TOWNSEND LABORATORIES
13 Townsend St. Dept. 17 CHICAGO, ILL.

10 Days FREE TRIAL
You are the Judge!

TOWNSEND LABORATORIES
713 Townsend St., Dept. 17 Chicago, Ill.
Gentlemen: Attached find \$1.00. Kindly send at once Townsend "B" Socket Power Unit, C. O. D. for \$5.85, plus postage, on guaranteed 10-day free trial.

Name.....
Address.....
City..... State.....

Eternal Life
We cannot guarantee eternal life, but we do guarantee the AEROVOX FILTER CONDENSER when properly used to outlast all the other equipment used in conjunction with it.

WHY???
Because—
each section of a block is individually sealed and impregnated against moisture absorption.
the safety factor used in manufacture, testing and rating will permit indefinite continuous operation at the rated working voltage without injury.

For all eliminators

AEROVOX
"Built Better"
70 Washington St., Brooklyn, N. Y.

Eastern	Central	Mountain	Pacific
KTHS (384.4m-780kc) Violet Belding, contralto. 9:15			
WFAF (491.5m-610kc), WGR (302.8m-990kc), WCAE (516.9m-580kc), WSAI (361.2m-830kc), KSIJ (545.1m-550kc), WCCO (405.2m-740kc), Giuseppe DeLuca, baritone. 10	WEEI (447.5m-670kc), WRC (468.5m-640kc), WWJ (352.7m-850kc), WGN (305.9m-980kc), WOC (374.8m-800kc), WGY (379.5m-790kc). 8:15		
WMBB (252m-1190kc) Trianon orchestra. 11:40			
WGN (306m-980kc) Albert Meuer, organist. 12:15 a. m.			
WFB (336.9m-890kc) Rockhill Theater organ concert. 10:15			

MONDAY, OCTOBER 24 Headliners

Eastern	Central	Mountain	Pacific
KMA (394.5m-760kc) Old Time music; vibraphone and marimba, Hugo Heyn. 7:28			
WDAF (370.2m-810kc) U. of Kansas. 6:28			
WGY (379.5m-790kc) "Footnotes," T. Arthur Cohen. 7:30			
WCCO (405.2m-740kc), Curtis hotel orchestra. 6:30			
WJZ (545.3m-660kc), KDKA (315.9m-930kc), WBZ (333.1m-900kc), KYW (526m-570kc), WRC (468.5m-640kc), WIAS (461.3m-650kc), WSB (475.9m-630kc), WSM (340.7m-880kc), WPAI (285.5m-1050kc), WJR (440.9m-680kc), WOC (374.8m-800kc), WHAM (277.6m-1080kc), WCCO (405.2m-740kc), WBT (285.8m-1160kc), WTMJ (293.9m-1020kc), Roxy and his gang. 8:10			
WLW (428m-700kc) Happy Harmony Boys. 9			
KFAB (309m-970kc) A. C. Sextet. 7			
KOA (325.9m-920kc) Sheuerman's Colorado orchestra. 8			
KTHS (384.4m-780kc) Orchestra concert with Ted Fiorito and his band. 10:15			
WRVA (254.1m-1180kc) Four Deuces. 8:15			

TUESDAY, OCTOBER 25 Headliners

Eastern	Central	Mountain	Pacific
WLS (344.6m-870kc) Old Town Duo. 8:30			
KFAB (309m-970kc) U. of Nebraska. 7:30			
WLW (428m-700kc) Formica concert orchestra. 9:30			
KTHS (384.4m-780kc) The Junior Lions Harmony Four male quartet. 8:30			
WJR-WCX (440.9m-680kc) Fun off Stage. 10:30			
WTIC (535.4m-560kc) Akay Harmony Belles. 8:30			
WBB (336.9m-890kc) Blackface Comedians. 10:30			
WJR-WCX (440.9m-680kc) Red Apple club. 8:30			
WCCO (405.2m-740kc) Novelty program. 11			
KGO (384.4m-780kc) Pilgrims. 11:20			
WIBO (416.4m-720kc) The Radi-Owens, harmony duo. 10:20			
WGN (306m-980kc) Music Box. 9:20			

WEDNESDAY, OCTOBER 26 Headliners

Eastern	Central	Mountain	Pacific
KMA (394.5m-760kc) Music, markets, news. 7 p. m.			
WFB (336.9m-890kc) movie questions and answers, Journal-Post Movie Man. 6			

\$75 to \$125 Weekly

Charging Batteries Starts You

Let me show you how to make big money right from the start. I've prepared a FREE book explaining all details. First week's profit pays for all equipment. You can get all the battery charging business in your community with my Service Station Charger—it's years ahead of ordinary chargers—handles 50% to 70% more batteries. I explain everything—start you in a business of your own and put you on the way to big money. Write for FREE BOOK.

C. F. HOLMES, Chief Engineer, Dept. R.D. Independent Electric Works 5116 Ravenswood Ave. Chicago, Ill.

FREE BOOK—Just Out

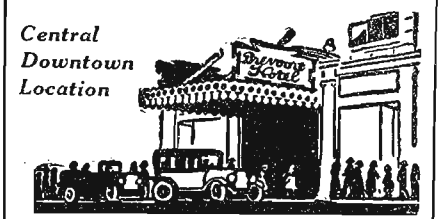

Hotel Brevoort Madison St., East of LaSalle CHICAGO

Distinguished for quality of service at moderate cost. Near the big downtown stores and theaters. Quick transportation to parks, beaches, summer gardens, golf grounds. Garage nearby extends special courtesies to Brevoort guests. Cars called for and delivered. Rooms: Single, \$2.50 to \$5 a day Double, \$3.50 to \$8 a day

Eastern	Central	Mountain	Pacific
WBBM (389.4m-770kc) National male quartet. 8:20			
WJZ (545.3m-660kc), WBZ (333.1m-900kc), KDKA (315.9m-930kc), KYW (526m-570kc), WBAL (285.5m-1050kc), WJR (440.9m-680kc), WLW (428.3m-700kc), WHAS (461.3m-650kc), WSB (475.9m-630kc), WMC (516.9m-580kc), WSM (340.7m-880kc), WJAZ (263m-1140kc), WBT (258.8m-1160kc), Maxwell hour. 10:30			
WLS (344.6m-870kc) Allstate Hour. 7			
WRVA (254.1m-1180kc) Richmond Musicians club concert. 8			
WJAZ (263m-1140kc) Earl Hoffman's Chez Pierre orchestra. 8			
WLW (428m-700kc) Crosley Instrumental trio. 10:30			
KFAB (309m-970kc) Milady Harmony Boys. 8:30			
CFCA (357m-840kc) Canadians. 9			
KGO (384.4m-780kc) vaudeville. 11 p. m.			
WIBO (416.4m-720kc) Sheridan Theatre stage stars and orchestra. 10:40			
WGN (306m-980kc) Melody tune. 9:40			

THURSDAY, OCTOBER 27 Headliners

Eastern	Central	Mountain	Pacific
WJR-WCX (440.9m-680kc) Randall Ramblers. 7:30 p. m.			
WLS (344.6m-870kc) Maurie Sherman's orchestra. 6:30			
WLW (428m-700kc) Crosley Mandolin quartet. 8:05			
KOIL (277.6m-1080kc) Vic's Travel letter s. 7:05			
WRVA (254.1m-1180kc) Navy Day program. 8:30			
WFLA (355.6m-820kc) Navy Day program, 7th Naval District Office of Key West, Fla. 6:30			
KTHS (384.4m-780kc) Mrs. Boyd Goodwin, soprano; Leona Latone, pianist. 8:30			
WGN (306m-980kc) Arabian Night's entertainment. 10:30			
WBBM (389.4m-770kc) Charlie Schultz, tenor. 9:30			
WJAZ (263m-1140kc) Studio program; Earl Hoffman's Chez Pierre orchestra. 11:15			
WIBO (416.4m-720kc) The Francis Sisters and Peter, harmony trio. 9:15			
CFCA (357m-840kc) Clifford G. McCormick, organist. 11:15			

FRIDAY, OCTOBER 28 Headliners

Eastern	Central	Mountain	Pacific
WTIC (535.4m-560kc) Esther A. Nelson, organist. 7:30 p. m.			

Eastern	Central	Mountain	Pacific
WRVA (254.1m-1180kc) Country Fiddlers. 8:20			
KMA (394.5m-760kc) Essex Municipal Band. 8			
KOIL (277.6m-1080kc) Billy and Helen. 8:30			
KTHS (384.4m-780kc) Requests by Ted Fiorito and his Arlington orchestra. 7:30			
WGN (306m-980kc) Paul Ash and his Merry-Mad musical gang. 8:30			
WTAG (516.9m-580kc) Hawaiian serenaders. 8:05			
WCCO (405.2m-740kc) Dance program. 10:30			
KFAB (309m-970kc) Leando string quartet. 9:30			
WJR-WCX (440.9m-680kc) Joe Higgins Old Time song review. 8:30			
WLS (344.6m-870kc) Little Symphony "Pop" concert. 11			
WIBO (416.4m-720kc) Dorothy Rae, soprano. 1:15 a. m.			
WBBM (389.4m-770kc) Organ club. 12:15			

SATURDAY, OCTOBER 29 Headliners

Eastern	Central	Mountain	Pacific
WLW (428m-700kc) Johanna Grosse, organist. 8:05			
WTAG (516.9m-580kc) WTAG Little symphony. 7:45			
WCCO (405.2m-740kc) Fireside Philosophies—Rev. Roy L. Smith. 7:45			
WSM (340.7m-880kc) Regular Farm program. 9:30 p. m.			
KFAB (309m-970kc) Buick Little symphony. 8:30			
WGN (306m-980kc) Over the Hills and Far Away. 10:30 p. m.			
WJID (365.2m-820kc) The Opera Guyed. 11 a. m.			

Football

California-U. S. C. at Los Angeles, KPO (422.3m-710kc), KFI (468.5m-640kc), Drake-Kansas at Lawrence, KFKU (245.1m-1180kc), Kansas Aggies-Iowa State at Ames, WOI (265.3m-110kc), Michigan-Illinois at Urbana, WGN (305.9m-980kc), WRM (272.6m-1100kc), Michigan State-U. of Detroit at East Lansing, WKAR (285.5m-1050kc), Minnesota-Wisconsin at Minneapolis, WAMD (225.4m-1330kc), Northwestern-Missouri at Evanston, WEBH (365.6m-820kc), WIBO (416.4m-720kc), Ohio-Chicago at Columbus, WEAQ (282.8m-1060kc), WMAQ (447.5m-670kc).

The New "ENSCO" 3-FOOT CONE

Wall Type Loud Speaker

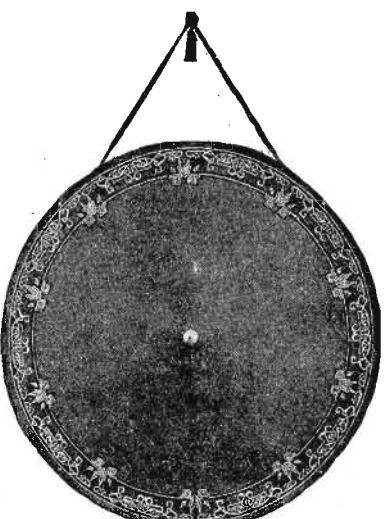

Standard "ENSCO" Kit \$10.00

With Hardwood Wall Frame, \$11.00 It contains "Enesco" Direct-drive unit, designed and patented by Clyde J. Fitch. Beautifully decorated Alhambra FON-O-TEX Cone Material; Metal Apexes; Extension Pin and 12 page illustrated Book of Instructions for easy assembly of any of six styles of Cone or Roll Shape, Wall, Pedestal or Console Speaker, sizes 24, 30 or 36 inches. You can build it in less than an hour. Static materially reduced—winter results all summer.

Endorsed by the leading engineers, magazines and newspapers as the outstanding development in radio speakers. Guaranteed to be the equal of any manufactured speaker regardless of price. The "Enesco" produces the truest tones you ever heard.

Your radio set is only as good as its speaker. The "Enesco" Cone will reproduce every tone your set delivers to it. Perfect reception—and at a price you can afford to pay. Go to your dealer and ask him to let you hear the "Enesco." If he hasn't been supplied we will send you one direct. You take no chance—our money-back guarantee protects you.

See Our Exhibit at the Radio Shows

Don't fail to visit our booths at the Boston and Chicago Radio Shows. Study the simple, practical "Enesco" unit.

"The World's Finest Loud Speaker"

The "Enesco" will open your eyes and your ears as to what radio reception can be. At your dealer's or direct from any of the offices listed below. Send check, money order or C. O. D. Shipping charges paid. In Canada the prices are \$11.50 and \$12.50. Absolute (money-back) guarantee.

ENGINEERS' SERVICE COMPANY 25 Church St., New York 73 Cornhill, Boston 28 E. Jackson Blvd., Chicago 331 Bay St., Toronto, Ontario

Who gets the difference?

Why do other good "B" Eliminators sell for as much as \$65.00—while the Ferbend sells for \$12.50?

Generally accepted in the minds of the radio public is the fact that "B" Socket Power is best from every standpoint—convenience, lasting satisfaction, better reception. There remains only the question of price. Of the best "B" Eliminators, many are as high as \$65.00, while the Ferbend—which is equal to any, not only in operation, but in quality, durability, workmanship and appearance—sells for only \$12.50.

Original cost less than half of any equipment of similar quality; lowest maintenance cost. Sooner or later you will change to "B" Socket Power. Why pay the difference? Model III for all sets using 90 volts, \$12.50. Model IV for extremely large sets and sets using power tubes; delivers up to 180 volts, \$17.50.

Tested and approved by the Rigid Laboratory Tests of Radio News and Popular Radio.

See Your Dealer or Send Direct

Shipment made direct on receipt of price, or C. O. D. if preferred. Use for 10 days to convince yourself—if unsatisfactory, write us within that time and purchase price will be refunded. Send Coupon TODAY.

FERBEND ELECTRIC COMPANY 417 W. Superior St., Chicago, Ill.

Your Proof of Lasting Satisfaction

"I have used your B Battery Eliminator for two years. Being an electrician, I wish to inform you that your Eliminator has given perfect satisfaction in every way."

S. O. Stives, Beaver Falls, Pa. "Have been using Ferbend B Eliminator for over a year and am more than satisfied with same."

J. W. Reites, New Orleans, La. "Your Eliminator has been in use now almost two years and still works great."

W. T. Henwood, Boulder, Colo. The first Ferbend B Eliminator is still in use and giving good service.

Form with fields for Name, Address, City, State, and checkboxes for Model III (\$12.50) and Model IV (\$17.50).

FERBEND "B" ELIMINATOR

SUNDAY, OCTOBER 30

Headliners

Eastern	Central	Mountain	Pacific
5 p.m.	4	3	2
KMA (394.5m-760kc)	St. Mary's choir.		
7	6	5	4
WIBO (416.4m-720kc)	"Gems of Music," fantasy program.		
9	8	7	6
WLS (344.6m-870kc)	WLS Little Brown church.		
9:15	8:15	7:15	6:15
WEAF (491.5m-610kc)	WEEI (447.5m-670kc)		
WGR (302.8m-990kc)	WRC (468.5m-640kc)		
WCAE (516.9m-580kc)	WWJ (352.7m-850kc)		
WSAI (361.2m-830kc)	WGN (305.9m-980kc)		
KSD (545.1m-550kc)	WOC (374.8m-800kc)		
WCCO (405.2m-740kc)	WGY (379.5m-790kc)		
Albert Spalding, violinist; Andre Benoit, pianist.			
10 p.m.	9	8	7
WMBB (252m-1190kc)	Trianon ensemble.		
11:20	10:20	9:20	8:20
WGN (306m-980kc)	Salernos.		
11 a.m.	10		
WBWB (389.4m-770kc)	Nutty Club.		
For Regular Features See Sunday, October 2.			

MONDAY, OCTOBER 31

Headliners

Eastern	Central	Mountain	Pacific
8	7	6	5
KMA (394.5m-760kc)	Ruby trio.		
8:30	7:30	6:30	5:30
WJAX (336.9m-890kc)	Shrine Chanters.		
9	8	7	6
KOIL (277.6m-1080kc)	Bits of This and That.		
WJR-WCX (440.9m-680kc)	Minstrels.		
9:10	8:10	7:10	6:10
WRVA (254.1m-1180kc)	Fireside quartet.		
9:30	8:30	7:30	6:30
WLW (428m-700kc)	Handbox ensemble.		
9:40	8:40	7:40	6:40
KTHS (384.4m-780kc)	Pete Phillips, tenor.		
10	9	8	7
KFI (468.5m-640kc)	Music Box hour.		
KTHS (384.4m-780kc)	Arlington Ensemble.		
10:15	9:15	8:15	7:15
WRVA (254.1m-1180kc)	East End Mandolin club.		
10:30	9:30	8:30	7:30
KTAB (309m-970kc)	Van Sickle Four.		
For Regular Features See Monday, October 3.			

New Radio Books

Books described in this column may be purchased at the list price from the Service Bureau of the Radio Digest Publishing Co., 510 N. Dearborn street, Chicago.

A NUMBER of authentic books have appeared during the current season of interest to the Radio fan who delves into the why and wherefore of Radio; and concerns himself with the progress of its development.

Probably the most complete compilation of "non-technical reference work, easy to read and easy to use," may be found in Drake's Radio Cyclopedic. The fly leaf explains that it covers "over 1,500 subjects arranged alphabetically, including instructions for building, operating and testing receivers, power units and Radiophone equipment. Arranged for use of set builders and designers; service and repair men; dealers and salesmen; experimenters and students; set owners and operators. It is edited by Harold P. Manly of the Radio-technic Laboratory, Chicago. The book contains 950 illustrations, circuit diagrams, constructional layouts and graphic curves." There are over 300 pages in the Cyclopedic and doubtless the book will receive a hearty welcome from persons who seek a convenient reference for all Radio technical terms and operations. Frederick J. Drake & Co., Chicago, \$6.

"RADIO communication in general, and broadcasting in particular, furnishes a new implement for the ancient art of defamation... it classes with the newspapers... if improperly used, it is a powerful weapon for character destruction."

This is just one of hundreds of legal phases pertaining to the uses of Radio discussed in The Law of Radio Communication by Stephen Davis, solicitor of the department of commerce, and formerly associate justice of the supreme court of New Mexico. The book was awarded the Linthicum Foundation prize by the faculty of law of Northwestern University, under the Charles G. Linthicum Foundation, June, 1927. Some of the subjects treated are: "Paid Advertising, Use of Wavelengths for Broadcasting, Call Letters (advertising value—property rights), The Right to Engage in Radio Communication, Federal Jurisdiction, The Radio Act of 1927, Broadcasting of Copyright Matter, Control of Broadcast Programs and International

Law. The author dedicates the book to Secretary Hoover. McGraw-Hill Book Co., \$3.

Detects Airplanes

WASHINGTON.—If future wars are to be fought in the air, as some military authorities contend, a new Radio amplifying device, developed by the U. S. bureau of standards, should become the most valuable equipment in the defense of large cities.

It consists of a large horn, a perforated brass plate, an aluminum diaphragm and a Radio amplifier, a combination that makes it possible to detect the sound of an airplane 20 miles away.

More surprising than this is its ability to differentiate the whirring noise of an airplane from any other sounds. Furthermore, it tells the direction of the sound over distances of from eight to ten miles.

The Radio Listener's Red-Book

—More Necessary Now Than Ever!

With the new wave lengths now in use, every listener should have one of the new Red Books to find stations quickly and easily. It takes the guesswork out of tuning.

Authentic information regarding each station obtained direct from RADIO COMMISSION at Washington, D. C. effective Sept. 1, 1927.

All stations in the United States, Canada, Mexico and Cuba listed three separate ways; by frequencies (kilocycles) and corresponding wave lengths (meters), by call letters, and by locations (city), giving owners' names. The Red Book also has a copyrighted method of ready-reference cross-indexing which makes only one logging section necessary for all three lists. FALL 1927 EDITION NOW READY.

Stations in each of the broadcasting "chains" are shown in separate list in addition to being so indicated in the three regular lists.

ONLY **25c** PER COPY

Contains large broadcasting station map in two colors showing time zones, direction and distances, and a two-page "Radio Doctor" giving trouble information and remedies and telling about "interference."

If your Radio or news dealer can't supply you, copies will be mailed postpaid on receipt of 25 cents each.

THE WAYNE ANDREWS CO. 1001 Central Bldg. Fort Wayne, Ind.

More than an ordinary log

Dealers

Radio dealers stock the RED BOOK in preference to all other logs because it is the most authentic book of its kind in print and helps their customers get better satisfaction out of their sets. News dealers sell it because it sells quickly and always repeats from issue to issue. Get your stock now!

50 or less, 40% discount (15c each). 100 or more, 44% discount (14c each). Special Quantity Prices

CARTER
PARTS
used in
"A-C Super
operated from light
socket"
as described in this issue.
Any dealer can supply
In Canada: Carter Radio Co., Limited, Toronto



TOBE TINY TOBES
CONDENSERS—RESISTORS
Specified—Used—Universally
TOBE DEUTSCHMANN CO. Cambridge, Mass.

RADIO WHOLESALE
Write for my Big 1928 Radio Catalog—just off the press. Thousands of marvelous bargains in nationally advertised goods. All the LATEST IN RADIOS and equipment. Lowest wholesale sale prices. Agents Wanted.
FREE Log and Call Book and Catalog. Get your copy today. Send postcard now!
American Auto & Radio Mfg. Co.
HARRY SCHWARTZBERG, PRES.
Dept. 113, American Radio Bldg., Kansas City, Mo. 3

Tone Control from Your Easy Chair!



The New No. 3 Centralab Modu-Plug
With 20 Feet of Cord
Just lounge in your easy chair, and let the program come in smoothly modulated as it changes in character. No more jumping up to adjust the dials every time the station changes from vocal to orchestration. Simply tune with your dials to maximum strength and clarity of station, then from your easy chair, with 20 feet of cord, use Modu-Plug No. 3 to smooth the reception down to any degree of tone, without changing the ratio of high and low notes. Centralab Modu-Plug gives any degree of volume from a whisper to maximum. Can also be used to provide a very convenient method of connecting two speakers in series at some distance from the receiving set. No. 3, \$3.00; Regular Cord Type with 24 inches of cord, or Jack Type, each \$2.50. All mailed C. O. D.

Added Power for Tone and Volume Centralab Tone Amplifier

Works wonders on any sets having two stages of amplification. Adds a power stage of amplification, which gives better tone and greater volume, without distortion from ANY station tuned in. Your present set will equal or surpass the new models. Using the -71 tube, Centralab Tone Amplifier reproduces tone and volume so faithfully that the artist seems actually moved into your presence. One knob controls volume from whisper to maximum. A tone filter protects the speaker. Easily attached in a few minutes without tools or alterations. A demonstration will convince you. At your dealer's, or C. O. D.

Model 100, for sets with 6-volt, "A" Battery. Uses CK 371 or UX 171 tubes. Model 200, for dry cell operated sets only. Uses UX 120 or CX 220 tubes.
\$16.00 Either Model—walnut finish cabinet—without tube.

CENTRAL RADIO LABORATORIES
12 KEEFE AVE., MILWAUKEE, WIS.



BUY the only TIME-TESTED ELECTRIC RADIO at AMERICA'S LOWEST PRICE \$100



HERE is the radio that's ALL Electric — not only NO BATTERIES— but NO ELIMINATORS— no outside attachments, no acids or water! Its tone is something to marvel at— rich, full and mellow. Distant stations come in with real volume—and without distortion. The cabinets are in Genuine Solid Philippine Mahogany—substantial and BEAUTIFUL! You don't experiment when you buy a STEINITE Electric—thousands have been in use for more than a year! See it—hear it—dealers everywhere are showing it!

STEINITE RADIO CO.
General Sales Offices: 506 S. Wabash Ave., Chicago
Factories: Atchison, Kansas

Six tubes—2 illuminated dials
Licensed by R. C. A. only for Radio amateur, experimental and broadcast reception.

HL-BOY CONSOLE \$165
TABLE MODEL WITH SPEAKER \$135

Steinitz
ELECTRIC RADIO

Scanlan Electric Has New Transformer Idea

POWER tubes now on the market for the purpose of securing greater volume without distortion are excellent products but they require higher plate voltage and in order to protect both the speaker and set, and to obtain this greater volume with clarity of reception, it is necessary to hook up the loud speaker to the set through an output transformer.

The Scanlan Electric Manufacturing company of Chicago—who for several years have been furnishing transformers as standard equipment to over twenty-five set manufacturers—are putting on the market a new idea in an output transformer wherein beauty of appearance, economy and perfection of operation are combined and which is called the Scanlan "Speaker Chest," an output transformer for power tube equipment.

This accessory of metal with the transformer sealed inside of it, has all the appearances of a cigarette container in the shape and design of a treasure box. It is finished in antique bronze, antique silver, antique brass and a walnut shade which will harmonize with practically any set and speaker.

This design and the four finishes do away with the crude appearance of a transformer in its factory finish sitting on top of the set or beside the speaker, and adds distinctive note of harmony to the appearance of the entire radio unit.

The Scanlan Electric Manufacturing company have decided to market this product directly through jobbers and have started a national advertising campaign to assist the merchandising of this product for both the jobber and the retailer.

Fighting Bob Brown Meets th' Top Sergeant

POSSIBLE creaks or scratchy sounds seeming to come from the WGR transmitter at Buffalo should not be attributed to the well known static or loose connections in the receiver.

It's just Bob Brown, the announcer, taking a deep and painful breath and incidentally causing the broken ends of a couple of ribs to rasp together. All the other ribs are hitting on twenty-two. The two that are missing, ah, well you see Bob did his bit at the Pine camp with the 174th infantry and the top sergeant, just like all top sergeants, knows his onions when it comes manhandling—especially when it involves a pair of padded mitts.

"So Bob," as Bruce Stewart tells it, "being in the announcing habit broadcasts to the regiment he'd go to the sarge two rounds for a knock out. Well two rounds weren't scarcely necessary because when they took Bob out on the stretcher there was still time to spare. But you gotta give the boy credit. He's ready to do the Dempsey and make a come-back and has issued a challenge to all announcers under the heavy for the WGR area champion.

Sonochorde Expands Factory

There is no retrogression in Radio insofar as the manufacturers of the Sonochorde Cone Speakers are concerned. Makers of the speaker, the Boudette Mfg. Co., have just increased production capacity 150 per cent. The factory is located at Chelsea, Mass., and is now equipped to produce 2,500 speakers a day.

The Boudette company, comprised of a father and three sons, began the loud speaker manufacturing business in 1922 and during the first year considered 100 instruments a month a considerable achievement. Their success is indicated by the statement that they have never been able to keep up with their orders, even

when producing 1,000 a day last year. There are four models this season; the new Junior is considered most popular.

Convenient for Invalids

"Remote control" on a receiver is announced by the manufacturers of the new Thermodyne. It is an attachment adjustable to any single dial receiver, making it possible for the listener to sit where he likes and do his tuning where he sits. This portable dial is also regarded as a convenience for invalids, who may do their tuning in bed. The receiver may be located in any part of the house and the dial in any other room.

"When a station is hard to get, and it is a distant hit

Use a REESONATOR"

Make your set up to date by equipping it with this wonderful improvement which will give you additional range and volume to a degree which you formerly considered infinitely out of your reach. Through actual tests we have found that the Reesonator will boost your volume from three to twenty times on distant stations. Enables battery current to be reduced and increases the life of your tubes. Reduces interference and increases selectivity. As proof of the soundness of this instrument: Several of the latest and foremost radios have this principle incorporated in their 28-tube models. Adapted especially for Atwater-Kent models 30, 32, 35 and similar single dial radios. Can also be used to great advantage on two or three-dial tuned radio frequency sets. Can be installed by anyone without tools in less than a minute.

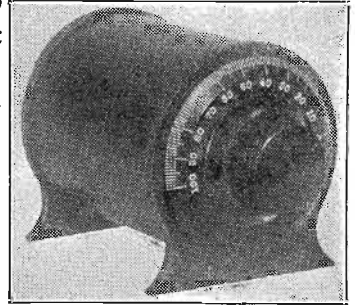

Not a wave trap Pat. Pend.

WE GUARANTEE SATISFACTION

Try one for three days at our risk. If not thoroughly satisfied your money will be cheerfully refunded. State type of machine you have when ordering. Sent complete and P. P. on receipt of \$4.75 or sent C. O. D. Dealers' inquiries are solicited. References: First National Bank, Fargo National Bank.

F. & H. RADIO LABORATORIES, Dept. 105
Fargo, N. Dak.



When in New York Reside where the New Yorkers reside—at Beautiful Standish Hall

THIS magnificent Apartment Hotel overlooks Central Park, faces the Museum of Natural History and is only a few minutes from Broadway—Fifth Ave. and the Shopping and theatre centers. The rooms are uniquely large and furnished with luxurious refinement. An ideal summer residence for families.

During the Spring and Summer months a Special Discount is offered to transient and permanent guests.

Send for Illustrated Booklet and Rates

Standish Hall
45 W. 81st St. New York

QUIT TOBACCO



No man or woman can escape the harmful effects of tobacco. Don't try to banish unaided the hold tobacco has upon you. Join the thousands of inveterate tobacco users that have found it easy to quit with the aid of the Keeley Treatment.

KEELEY TREATMENT STOPS Tobacco Habit

Quickly banishes all craving for tobacco. Write today for Free Book telling how to quickly Free yourself from the tobacco habit and our Money Back Guarantee.

THE KEELEY INSTITUTE
Dept. B400
Dwight, Illinois

Latest and Finest Loud Speaker for your Radio

Here is the newest and latest scientific development in Radio Loud Speakers—a combination cone type speaker with a resonant chamber—the famous All-American Reproducer. No snarling, slurring or tubbiness; no distortion at any volume; every bit of delicate tone shading faithfully reproduced. The last word in loud speakers for any radio up to 10 tubes.

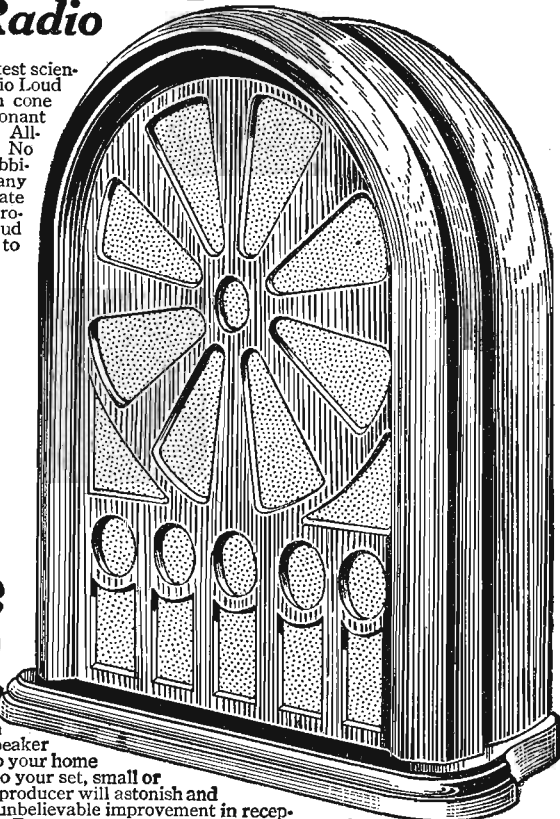

\$1.00 down
Brings it on
Free Trial

Yes, only \$1.00 with coupon brings this amazing loud speaker—the best radio affords—to your home on 30 days trial. Attach it to your set, small or large, the All-American reproducer will astonish and delight you by the almost unbelievable improvement in reception over your old speaker. Every note, every word—clear, full-toned and natural. Equipped with an output transformer, it may be used on sets with power amplifier tubes. The metal case is beautifully designed and finished in permanent walnut brown enamel. An exquisite ornament in any home. 15 in. high by 10 in. wide; comes complete with attachment cord. After 30 days if not delighted, send it back at our expense and your \$1.00 plus transportation charges will be refunded at once. You don't risk a penny.

\$4.00 a Month

If satisfied, pay only \$4.00 a month until you have paid our special introductory price, only \$25.00. The same price dealers ask for spot cash—on easy payments.

Send Coupon NOW

Order by No. Y157A. \$1.00 with coupon; \$4.00 monthly; Total price only \$25.00. Shipping weight about 15 lbs.

Free Catalog of home furnishings sent with or without order. See coupon.

Straus & Schram
Dept. R3517 Chicago

Straus & Schram, Dept. R3517 Chicago, Ill.

Enclosed find \$1.00. Ship All-American Loud Speaker. I am to have 30 days free trial. If I keep the speaker I will pay you \$4.00 monthly. If not satisfied, I am to return the speaker at your expense and you are to refund my money and any express charges I paid.

All-American Loud Speaker, No. Y157A, \$25.00

Name _____

Street, R.F.D. or Box No. _____

Shipping Point _____

Post Office _____ State _____

Married or Single _____ Nationality or Color _____

If you want ONLY our free catalog of home furnishings mark X here

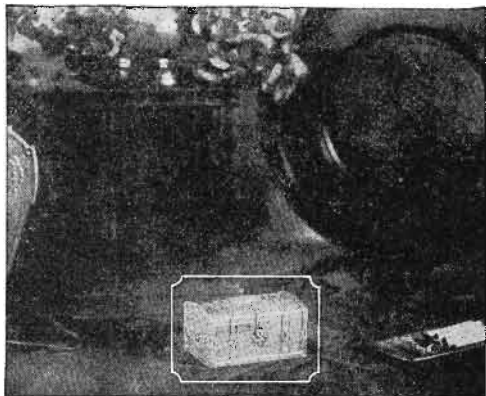

The SCANLAN SPEAKER CHEST

An Output Transformer for Power Tube Equipment

PROTECTION - ECONOMY - CLARITY

Combines charm of appearance and perfection in operation to fill the increasing demand for an output transformer which will protect the speaker unit from the higher plate voltage required by power tubes.

The Scanlan Speaker Chest will greatly improve tone quality and volume. Also will protect speaker unit on sets not using power tubes. Manufactured by a company who for several years have been furnishing transformers as standard equipment to over 25 set manufacturers.

SCANLAN ELECTRIC MANUFACTURING CO.
1113-19 N. Franklin Street, Chicago, Ill.

Our Jobbers Sale Plan is a real money-making opportunity. Upon receipt of your inquiry we will be glad to send full details.

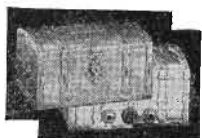

The Scanlan Speaker Chest will be backed by a National Advertising Campaign.

Tahiti Fan Hears U. S. Broadcasts

Just Two Listeners to 80 Islands—Lack of Battery Facilities Discourages Others

Out of the interesting fan mail at WSBC, Chicago, came this letter from Papeete, Tahiti:

"The other night when trying to avoid KFKX in order to catch CNRV I caught suddenly WSBC. Your announcer was asking us to write to you about batteries. And so I write. First you will have to locate me on the chart of the South Seas and your announcer certainly will be surprised to hear that his voice is as clearly heard 6,000 miles away as it is at WSBC station. And so are WLIB, WJF and WAHG and others. My set is an ordinary neodyne, 5 lamps; A battery, Philco 6 V; and 3 sets of Willard 24 (WTAM) for B and a C of 5. This being known by you, I come to the business part of my letter.

"Here in Tahiti we have great trouble from our batteries. We are only two Radio fans here. Why? Because other people have tried but cannot stand the expenses of keeping their batteries in order.

"First, Papeete is the only place amongst 80 islands that enjoys electricity. Electricity people ask \$2 to a charge for any battery. Well, 79 islands and towns around cannot enjoy Radios because there is no way, no possibility, for ANY price, to charge batteries.

"Second, Those islands which are flush with the ocean are very damp, salty dampness, and subject to the great humidity that ruins any battery in no time.

"However, we have any number of motor ships, but all of them use wet batteries. Those last long and are easily recharged. If you could supply wet batteries A, B and C, I feel sure that the 79 other islands would very much appreciate your supplies. Wet batteries alone can popularize Radio on our islands.—Emmanuel Rougier, Papeete, Tahiti."

CeCo Shows Humless AC Tubes for Socket

GETTING away from the A. C. hum is one of the virtues of a new A. C. tube recently brought out by the C. E. Manufacturing Company, Incorporated, Providence, R. I. In fact, there are two new A. C. tubes in this line.

One type will be known as the M-26 and is a 1½ volt filament tube. This tube is best suited for radio and audio stages and shows a remarkable freedom from A-C hum even under the most strenuous operating conditions.

The other new tube will be known as type N-27 and also operates on raw A-C. This tube is of the separate heater type with a five prong base carrying the cathode connection in the base itself. This tube is particularly suited for use as a detector, although it may be used as an amplifier as well.

The heater filament draws 1.75 amps at 2.5 volts.

The general characteristics of these A-C tubes follow closely those of the "CeCo" type "A" and vary only in operating conditions. For this reason "CeCo" types M-26 and N-27 may be used with superior results in any set specifying tubes of this type.

Communicates 190 Miles With Flash Lamp Power

LONDON.—The extraordinary high efficiency with which communication may be effected over comparatively long distances is demonstrated by an experiment recently

conducted by L. A. C. Lawler, a London fan, transmitted with the call sign "G61.R."

Mr. Lawler succeeded in securing two-way communication with another amateur in Mons, Belgium, using a power equivalent to that consumed by a flash-lamp bulb. The distance is about 200 miles.

"Echo" from Belgium

Mr. Lawler, while conducting some tests, had the misfortune temporarily to lose the services of his generator. Rather than forego his tests he continued with a local test, using a small high-tension battery of only 20 volts. At the conclusion of his experiments he was amazed to hear a Belgian fan replying with the call sign "S5" reporting that his signals were being received at good strength.

When the 20 volts had been reduced step by step, to only 4 volts, and the Belgian fan still reported readable signals, although rather faint, Mr. Lawler almost believed himself the victim of a practical joke.

SCHENECTADY.—The Madrigal Quartette at WGY is creating a mild sensation by its rapid gain of fan following.

FROST-RADIO

Ask Your Neighbors

DE LUXE APPARATUS

FROST DE LUXE VARIABLE HIGH RESISTANCES

Have continuously variable resistance adjustment of liquid-like smoothness. The unique Frost roller contact arm eliminates friction and reveals a new order of more than a million revolutions. Highly polished Bakelite shell, transparent Bakelite cover, hand-buffed nickel plated metal parts. Two or three terminal type, less switch, \$1.75. With switch, \$2.10.

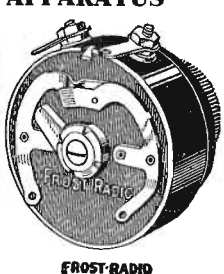

FROST GEM RHEOSTATS

They are good little rheostats and as well made as our regular rheostats in every way. Diameter is only 1½ in. Resistance wire wound on flexible Bakelite strip which cannot warp, break or char. All exposed metal parts are nickel plated and hand buffed. Supplied with sturdy, positive acting switch, if desired. No finer small rheostats made than these. Less switch, .75c. With filament switch, \$1.00.

FROST-RADIO

HERBERT H. FROST, Inc.
Main Offices and Factory, Elkhart, Ind.

The LOGICAL Filament Control

AMPERITE is the only self-variable filament control. Automatically does the work of hand rheostats and delicate meters. Proved for 6 years. Specified in every circuit. Entirely different from fixed filament resistors. Accept nothing but AMPERITE.

FREE—"Amperite Book" of the season's best circuits and let us construct data. Write Dept. RD-10 RADIALL COMPANY, 50 Franklin St., New York



AMPERITE

REG. U.S. PAT. OFF.

The "SELF-ADJUSTING" Rheostat

Amazing Success by "Hitching Your Radio to a Star Antenna System"



New appliance utilizes principle of the lightning rod. From all over the world come daily reports of satisfaction and superiority. Packed with wire, insulators, mast seat, all complete except pipe.

\$6.50 Postpaid
Literature on request.

Order Direct Now or at your Dealer.

Star Antenna Products

820 S. Main Street
Elkhart, Indiana

BIG DEALERS on DISCOUNTS

Lowest Wholesale Prices thousands of RADIO SETS, PARTS, KITS.

NATIONALLY ADVERTISED

Midland Wholesale Co.
5116 Ravenswood Ave.
Chicago, Illinois
Dept. R. D.

Just Out! Write for FREE BOOK

TONE :: VOLUME :: DISTANCE

RADIOLITE

Eliminates BATTERY NOISE

and you'll be surprised how little "static" you really have.

RADIOLITE prevents plate sulphation—giving LONGER life to the battery—MORE real power, and ELIMINATING battery noises. Mail YOUR order NOW!

Radiolite \$1.50

for ONE Battery Postpaid

Check or Money Order to
RADIOLITE BATTERY COMPANY
Asheville, N. C.

Balkite Adds New Line

The Balkite line of B power units and chargers has been augmented by the new Balkite Combination Radio Power Units, which once connected to the A battery and set, and plugged into the light socket, supplies automatic power to both circuits. This unit is controlled by the filament switch already on your set and is entirely automatic in operation.

Like all other Balkite units it does not use tubes and will serve any set requiring 4 or 6-volt A batteries, and up to 30 milliamperes at 135 volts of B current.

6 TUBE RADIO

ONE DIAL Latest advanced circuit. All steel chassis totally shielded. Balanced parts of best quality. Marvellous power and selectivity. Gets the long range stations as clear as a bell. One dial single control. An unsurpassed value—just one of our many mighty bargains.

Only \$32.50

FREE Log and Call Book and Big New Catalog—just off the press. Full of Radio Bargains. Send for your free copy now!

American Auto & Radio Mfg. Co.
HARRY SCOWARZBERG, Pres.
Dept. 112, American Radio Bldg., Kansas City, Mo.

What Kind of Voice Has Your Loud Speaker?

Does it Surr-ah? Does it Whine?



or Does it register clear, natural Human Tones?

The New Muter Clarifier

(Output Transformer)

on your set will astonish and delight you by immediate, almost unbelievable improvement in reception. In nine cases out of ten that weak, distorted voice issuing from the speaker unit is suffering paralysis from high "B" Voltage. The Clarifier protects Speaker coils from this shattering current, assuring longer life as well as strong, full tone, clarity and volume.

If your speaker is one of the great majority that fail to respond properly to the output of the set—you need a Muter Clarifier. It's the only thing that will remedy the cause. Easily attached in a few seconds without disturbing set. Try it out to your own satisfaction on our liberal guarantee—you won't recognize your set!

See Your Dealer—Or Send Direct

Dealers can easily secure Muter Products for you from leading Jobbers. If, however, you have any difficulty in obtaining from your dealer, mail coupon direct to us. Prompt shipment will be made upon receipt of price or C. O. D. if preferred. Give your speaker a chance to produce its utmost. Mail coupon today.

Leslie F. Muter Company

76th and Greenwood
Dept. 823-N CHICAGO, ILL.

Dependable Products



The Complete Quality Popular Priced Line

Send for comprehensive Catalog



Use This Coupon!

LESLIE F. MUTER CO.
76th and Greenwood Ave.
Dept. 823-N Chicago, Ill.

Send Muter Clarifier at once, postage prepaid. \$5.00 is enclosed.

Send C. O. D.

Send complete Muter Catalog.

Name

Address

City

State

The newest, most luxuriously furnished and conveniently situated hotel in the metropolis. The town home of many distinguished authors, producers and stars of the stage & screen

The BELVEDERE

New York

48th STREET WEST of BROADWAY, (Near Times Square)

Large room, private bath for one—Four Dollars • For Two Five Dollars (serving pantry optional) ~ ~ ~ Restaurant BOOKLET FREE

CURTIS A. HALE, Managing Director

BENJAMIN

Cle-Ra-Tone Sockets



Spring Supported Shock Absorbing

Specified for the New Radio Digest A-C Super

Used the world over by set builders who know and want the best. Tube "floats" on finely tempered springs. One-piece terminal to tube connection. Knurled nuts for binding post connections or handy lugs for soldering. The choice for practically every prominent circuit for several years. Among other recent hook-ups for which it has been specified are:

Magnafomer 9-8, L.C.-28, Camfield Super-Selective 9, Lynch Suppressor Circuit, H.F.L. Nine-in-Line, World's Record Super 10, Strobodine 8, Melo Heald Fourteen, St. James Super, Two-Dial Equamatic, Qualitone 6, Knickerbocker 4, Hilograd Receiver, No. 9040—With mounting base....75c
No. 9044—For mounting to 3/8" or 1/2" panel.....50c

New "Y" Type Socket for 5-Prong Radio Tubes



Spring suspension adds to life of tubes by absorbing mechanical shocks and jars, while permitting tubes to operate at maximum efficiency.

No. 9036—With mounting base....\$1.20
No. 9037—For mounting to 3/16" or 1/8" panel.....90

At All Radio Jobbers and Dealers
Made by
Benjamin Electric Mfg. Co.
New York Chicago San Francisco

OFFICIAL CALL BOOK AND LOG

Corrected Every Issue

KDKA
E. Pittsburgh, Pa., 315.6m-950kc. 50,000 watts. Westinghouse Elec. & Mfg. Co. Daily ex Sun, 10 am, 2:30, 5:35, markets, weather; 11:57, time; 2:30 pm, and every 30 min, baseball; 5, dinner concert; 6:20, road reports. Daily ex Sun, Sat, 7, WJZ. Tues, 6 pm, sacred songs; 10:35, Grand theater revue. Wed, 6:30 pm, power; 7:30, Homer Smith, concert. Thurs, 6:30, Fri, 10:30 pm, dance program. Sun, pm, WJZ; 5:30, 6:30, baseball; 6, Midsummer Dream, KDKA Little symphony; 7:15, WJZ. Eastern.

KDLR
Devils Lake, N. Dak. 230.6m-1300kc. 15 watts. Radio Elec. Co. Announcer, Harold Serungard. Daily ex Sun, 12-12:30 pm, weather, 6-6:30, markets. Mon, 9:30-11:30 pm. Wed, 8-9 pm, band. Sun, 11 am, church, 4:30-6. Founded Jan. 25, 1925. Central.

KDYL
Salt Lake City, Utah. 258.5m-1160kc. 100 watts. Intermountain Broadcasting Corp. Announcer, Philip G. Lasky. Slogan, "Out on the Great Divide." Daily ex Sun, 2-5 pm, 6-12 mid. Sun, 10-12 am. Mountain.

KELW
Burbank, Calif. 228.9m-1310kc. 250 watts. Earl L. White. Daily ex Sun, Wed, Fri, 11 am-1 pm; 6-7, 8-10. Fri, 5-6 pm. Last Sat, in month, 10-11 am. Pacific.

KEX
Portland, Ore. 239.9m-1250kc. 2,500 watts. Western Broadcasting Co. Daily ex Sun, 10-12:30 pm, 6-12 mid. Sun, 6-11 pm. Pacific.

KFAB
Lincoln, Nebr. 309.1m-970kc. 2,000 watts. Nebraska Buick Auto Co. Announcer, Gayle Grubb. Daily ex Sun, 9:30-9:55 am, weather reports; 3-4 pm, Mon, Tues, Wed, Fri, 10:30-11 am, home economics. 11:45-12:30 pm, 1:15-1:30 pm, talks; 3:30-4 pm, 5:30-6:30, 8:05-8:30, college of agriculture; 8:30-10:30, Tues, Sat, 3-4 pm. Sat, 9:30-9:55 am; 5:30-6:30 pm, 8:30-10, 12-2 am. Sun, 4-5 pm; 9-11. Founded Dec. 4, 1924. Central.

KFAD
Phoenix, Ariz. 272.6m-1100kc. 500 watts. Electrical Equip. Co. Announcer, Arthur C. Anderson. Slogan, "The Voice of Phoenix." Daily ex Sun, Mon, 12:15-1:15 pm, 3-4, 6-7, 8-9. Daily ex Sun, Wed, 6-7 pm; 9-11, concert, news, stocks. Thurs, 9-10 pm. Sun, 11 am, 6 pm, 8. Installed July 30, 1925. Mountain.

KFAU
Doise, Idaho. 285.5m-1050kc. 4000 watts 6 am-6 pm. 2000 watts. Independent School Dist. of Boise. Mon, Tues, Wed, Thurs, Fri, 12:30-1 pm, weather, markets, U. S. program. Tues, 7:30-8 pm, children's hour; 8-10, music. Thurs, 8-10 pm. Sun, 3-4 pm, 7:30-9 pm. Founded Oct. 1921. Mountain.

KFBB
Havre, Mont. 275.1m-1090kc. 50 watts. F. A. Burrey Co. Announcer, E. A. Baer. Daily ex Sun, 12:30-1:30 pm, music, markets, weather reports. Wed, 7:30-9 pm. Sun, 10:30 am, 2:30 pm. Founded 1921. Mountain.

KFBC
San Diego, Calif. 247.8m-1210kc. 100 watts. Howard Shores. Daily ex Sun, Fri, 12-1 pm. Daily, 8-10 pm. Sat, 10 pm. Sun, 9-10 am. Bible lesson, sermon. Pacific.

KFBK
Sacramento, Calif. 535.4m-560kc. 100 watts. Sacramento Bee. Kimball-Hanson Co. Mon, Announcer, K. Clark. Mon, Thurs, Sat, 7:30-10 pm. Founded 1921. Pacific.

KFBL
Everett, Wash. 223.7m-1340kc. 50 watts. Lesse Bros. Mon, Wed, Fri, 6:30-8 pm. Tues, Thurs, Sat, 7-8 pm. Thurs, 9:30-10:30 am. Sun, 11-12 mid. Pacific.

KFBW
Laramie, Wyo. 428.3m-700kc. 500 watts. Bishop N. S. Thomas. Announcer, F. C. Smith. Sunday services.

KFCB
Phoenix, Ariz. 243.8m-1230kc. 125 watts. Nielsen Radio Supply Co. Announcer, E. A. Nielsen. Slogan, "Kind Friends Come Back." Mon, Thurs, 8-9 pm. Sun, 12-2 am, 9:30-10:30 pm. Mountain.

KFCR
Santa Barbara, Calif. 211.1m-1420kc. 50 watts Santa Barbara Broadcasting Co. Daily ex Sun, 12-1 pm, 5:45-7, 7-7:20, 7:20-7:30. Mon, Tues, Wed, Thurs, 7:30-9:30 pm, Fri, 7:30-10 pm. Sat, 12-1 pm, 6:15-7:30 pm. Sun, 7:15-8:15 pm, 8:15-9:15. Pacific.

KFDM
Beaumont, Tex. 483.6m-620kc. 500 watts. Magnolia Petroleum Co. Announcer, Magnolene Mike. Slogan, "Kall for Dependable Magnolene." Tues, Fri, 12:30-12:55 pm, band concert; 8-10, concerts. Sun, 11-12 m, 8-9 pm. Founded Oct. 1, 1924. Central.

KFDX
Shreveport, La. 236.1m-1270kc. 250 watts. First Baptist church. Announcer, John S. Rarson. Wed, 9-10 pm. Sun, 10:50-12 n., 7:45-9. Founded 1922. Central.

KFDY
Brookings, S. D. 394.5m-760kc. 500 watts. State College of Agriculture and Mechanical Arts. Announcer, Don Williams. Daily ex Sun, 12:15-1:15 pm. Central.

KFDZ
Minneapolis, Minn. 215.7m-1390kc. 10 watts. Harry O. Iverson. Sat, 8 pm. Central.

KFEC
Portland, Ore. 214.2m-1400kc. 50 watts. Meier & Frank Co., Inc. Announcer, L. W. Jones. Daily ex Sun, 12 m, weather reports; 4-5 pm, music, 6-7. Pacific.

KFEL
Denver, Colo. 247.8m-1210kc. 250 watts. Eugene E. O'Fallon, Inc. Announcer, J. H. Hathaway. Daily ex Sun, 7:15 am, gym; 10, 11, 2, 4, 5, 6. Tues, Thurs, 8 pm, Fri, 8 pm, Sat, 9 pm. Sun, 9 am, 5 pm. Mountain.

KFEQ
St. Joseph, Mo. 230.6m-1300 kc. 1000 watts. J. L. Scroggin. Announcer, Clarence Koch. Daily ex Sun, 5:30-7:30 am, music, 8:30, 10, 11, 12, markets; 2, music; 6:30-7:30, 8:30-10. Founded 1922. Central. Founded Nov. 1921.

KFEY
Kellogg, Idaho. 232.4m-1290kc. 10 watts. Bunker Hill & Sullivan Mining & Co. Announcer, Walter C. Clark. Slogan, "Voice of the Coeur d'Alenes." Mon, Thurs, 7-8 pm. Sun, 11 am, 7:30 pm. Pacific.

KFGQ
Boone, Iowa. 209.7m-1430kc. 10 watts. Boone Biblical school. Founded April 1923.

KFH
Wichita, Kan. 245.8m-1220kc. 500 watts. Hotel Lassen. Announcer, J. L. Fox. Daily ex Sun, 8:30 am, 9, 10, 11, 1-2 pm, markets; 1:15, music, 7:30-9. Sun, 9:30 am, 7:30 pm. Founded Dec. 1, 1925. Central.

KFHA
Gunnison, Colo. 254.1m-1180kc. 50 watts. Western State College of Colorado. Announcer, E. Russell Wightman. "Where the Sun Shines Every Day." Tues, Fri, 7-9:30 pm. Founded May 1922. Mountain.

KFHO
Oskaloosa, Iowa. 212.6m-1410kc. 10 watts. Penn College. Announcer, Donald Haworth. Tues, Fri, 7 pm. Fri, 9:45 am. Sun, 4 pm. Central.

KFI
Los Angeles, Calif. 468.5m-640kc. 5000 watts. Earle C. Anthony, Inc. Announcer, Leslie Adams. Slogan, "A National Institution." Daily ex Sat, Sun, 5:30-11 pm. Sat, 5:30-2 am. Sun, 10-11 am, 6-11. Installed Spring, 1920. Pacific.

KFIF
Portland, Ore. 214.2m-1400kc. 50 watts. Benson Polytechnic School. Announcer, Albert Skei. Omar Bittner. Tues, 8:15-9:15 pm. Pacific.

KFIO
Spokane, Wash. 245.8m-1220kc. 100 watts. North Central High School.

KFIU
Juneau, Alaska. 225.4m-1330kc. 10 watts. Alaska Elec. Light & Power Co. Announcer, O. E. Schoenbell. Mon, Wed, Fri, 6-7 pm. Alaskan time.

KFIZ
Fond du Lac, Wis. 267.7m-1120kc. 100 watts. Fond du Lac Commonwealth Reporter. Daily ex Sun, 5 pm, news, markets, weather. Central.

KFJB
Marshalltown, Iowa. 247.8m-1210kc. 100 watts. Marshall Electric Co. Announcer, M. F. Easter. Slogan, "Marshalltown, the Heart of Iowa." Daily ex Sun, 10 am, 12-1:30 pm. Daily, 6 pm, 7. Tues, Fri, 8:30 pm. Sun, 11 am, 7:30 pm. Founded June 2, 1923. Central.

KJFF
Oklahoma City, Okla. 272.6m-1100kc. 750-1000 watts. National Radio Mfg. Co. Announcer, Tired Hand. Slogan, "Radio Headquarters of Oklahoma City—The City of Opportunity." Daily ex Sun, 9 am, music; 10:30, markets; 12-1:30 pm, music; 3-5, 7-10, Sun, 9 pm, 1. B. S. A.; 10, Men's class; 11, services; 8, services. Central.

KFJI
Astoria, Ore. 249.9m-1200kc. 15 watts. E. E. Marsh and Liberty theater. Announcer, E. E. Marsh. Wed, 11-11:30 pm, organ. Sun, 12:30-1:30 pm. Pacific.

KFJM
Grand Forks, N. D. 333.1m-900kc. 100 watts. University of North Dakota. Daily, 12m, 6 pm, 8. Central. Founded Oct. 1923.

KFJR
Portland, Ore. 282.8m-1060kc. 100 watts. Ashley C. Dixon & Son. Announcer, Ashley C. Dixon. Sr. Daily ex Sun, Sat, 5-6 pm, 7-8. Tues, 7-8 pm, 10-11. Thurs, 9:30-10:30 pm. Fri, 12-1 am. Sat, 1:30-3 pm, 5-6. Pacific. Founded May 18, 1925.

KFJY
Fort Dodge, Iowa. 440.9m-680kc. 100 watts. Tunwall Radio Co. Announcer, Carl Tunwall. Daily ex Sun, 10:30-11:30 am, 5:45-7 pm. Tues, 10-11:30 pm. Thurs, Fri, 8:30-9:30 pm. Wed, 3-4 pm. Sun, 11-12:30 pm. Founded Oct. 1923. Central.

KFJZ
Fort Worth, Texas. 249.9m-1200kc. 50 watts. W. E. Branch. Daily ex Wed, Sun, 10:01 am, 4-6 pm, 6:30-7, 8:30-9:30. Sun, 1-3 pm, 7-9:30 pm. Central.

KFKA
Greeley, Colo. 399.8m-750kc. 200 watts. Colorado State Teachers' College. Announcer, H. E. Green.

KFKB
Milford, Kan. 241.8m-1240kc. 2500-1500 watts. J. R. Brinkley, M. D. Mon, Fri, 6-7 pm, 8-10. Tues, Thurs, Sat, 6-7 pm. Wed, 6-10 pm. Sun, 8-10:30 am, 6-10. Central.

KFKU
Lawrence, Kan. 254.1m-1180kc. 500 watts. University of Kansas. Announcer, Leland Barrows. Mon, Thurs, 7-8 pm. Founded Dec. 15, 1924. Central.

KFKX
Chicago, Ill. 526m-570kc. 2500 watts. Westinghouse Elec. & Mfg. Co.

KFKZ
Kirksville, Mo. 225.4m-1330kc. 15 watts. State Teachers College. Announcer, F. M. Henry. Mon, 8:30-9:30 pm. Thurs, 8-9 pm. Founded 1923. Central.

KFLX
Galveston, Texas. 270.1m-1110kc. 100 watts. George R. Clough.

KFMR
Sioux City, Iowa. 440.9m-680kc. 100 watts. Morningside College. Daily ex Sun, Sat, 11:40-12:30 pm. Tues, Wed, Thurs, Fri, 7:30-8:30 pm. Founded 1924. Central.

KFMX
Northfield, Minn. 236.1m-1270kc. 500 watts. Carleton College. Daily, 10:30 am, time. Tues, 9:30 pm, talk. Wed, Fri, 9-10 pm, concerts. Sun, 7 pm. Central.

KFNF
Shenandoah, Iowa. 461.3m-650kc. 2000 watts. 6 am-7pm, 1000 watts. Henry Field Seed Co. Announcer, Henry Field. Slogan, "Friendly Station in a Friendly Town." Daily ex Sun, 6-8:30 pm, 10-11, 12:30-2 pm; 3, rocking chair time; 5-7. Sun, 10-11 am, 2 pm, 3-4, services; 6, Golden Rule, church service. Founded Feb. 1924. Central.

CHALLENGE!

ONE DOLLAR will be paid to the Radio fan submitting the most errors in any one station's listing in this Official Call Book and Log. Letters must reach Radio Digest office not later than a month from date of issue corrected. Readers are not limited to correcting one station, but such corrections must be certified by the stations themselves, and NOT by comparison to other so-called accurate broadcasting directories and lists. Readers also must live in same state or province as stations corrected are located. Station verifications must accompany corrections.

That's just how sure Radio Digest is that this Official Call Book and Log is correct! To make the challenge fair for everyone, broadcasting stations and their employes are barred from this offer.

In this issue is a complete alphabetical arrangement according to wave lengths, a wave length index, and a state, city index of stations. The information contained in each station data listing is given in the following order: Call letters, city, state, watts antenna input, owner's name, announcer's name, slogan used, if any, name of listener in "club," schedule of operating hours, and kind of time used, as "Central," "Mountain," etc.

Each issue of Radio Digest gives one the most complete and accurate Call Book and Log obtainable. This service is original with this publication, and has been maintained from the start. Right of reproduction without permission of any or all of the data contained herein is forbidden.

KFOA
Seattle, Wash. 447.5m-670kc. 1000 watts. Rhodes Dept. Store. Announcer, Luther J. Jensen. Slogan, "The Gateway to the Orient." Mon, 7-11 pm. Tues, Wed, Thurs, Fri, 12:30-1 pm; 2-2:30. Mon, 7-8 pm; 8:15-9, 9:30-11. Tues, 7:30-10 pm. Wed, 7-10 pm. Thurs, 6:30-11 pm. Fri, 7-12 mid. Sat, 7-7:30 pm; 8:30-9:30. Sun, 2-3 pm. Pacific.

KFON
Long Beach, Calif. 241.8m-1240kc. 500 watts. Nichols & Warriner, Inc. Announcer, Hal G. Nichols. Daily and Sun, 9:30 am-12 mid. Pacific. Founded March 1924.

KFOR
Lincoln, Nebr. 217.3m-1380kc. 100 watts. Howard A. Shuman. Daily ex Sun, 2:30-1:30 pm, 2-3:15. Mon, Tues, Wed, Fri, 6-4. Pacific. Central.

KFOX
Omaha, Nebr. 258.5m-1160. 100 watts. Board of Education. Technical High. Daily ex Sun, Sat, 12-1:30 pm. Tues, 7:30-9 am. Central.

KFOY
St. Paul, Minn. 285.5m-1050kc. 250 watts. Beacon Radio Service. Announcer, M. G. Goldberg. Daily ex Sun, 9 pm. Mon, 7 pm. Central. Founded Mar. 1924.

KFPL
Dublin, Texas. 275.1m-1090kc. 15 watts. C. C. Baxter, announcer. Mon, Thurs, 8 pm. Sat, 11 pm. Sun, 7:30 am, 1:30 pm. Central.

KFPM
Greenville, Texas. 230.6m-1300kc. 15 watts. The New Furniture Co. Announcer, Dave Ablowich, Jr. Slogan, "The New Furniture Co., the Home of Good Furniture." Located at Greenville, Texas, Where You Find "The Blackest Land, the Whitest People." Daily ex Sun, 1 pm, music. Tues, Wed, Fri, 8 pm. Sun, 11 am, services; 7:30 pm, irregularly. Central.

KFPR
Los Angeles, Calif. 232.4m-1290kc. 250 watts. Los Angeles Co. Forestry Dept. Irregular schedule.

KPFW
Carterville, Mo. 263m-1140kc. 50 watts. St. John M. E. church, S. Slogan, "Keeping Pace with Christ Means Progress." Daily ex Sun, 6:30-7 am, 1-2:30 pm, 2:30-3 pm. Central.

KFPY
Spokane, Wash. 245.8m-1220kc. 250 watts. Symons Investment Co. Announcer, E. B. Craney. Daily ex Sun, Sat, 9:45-11 am, 3-5 pm, 6-10:30. Sun, 7-12 mid. Pacific.

KFQA
St. Louis, Mo. 322.4m-930kc. 50 watts. The Principia. Sun, 8 pm. Founded May 9, 1924. Central.

KFQB
Fort Worth, Tex. 325.9m-920kc. 2000 watts. Lone Star Broadcast Co. Announcer, Roland M. Perry. Daily ex Sun, 9:30-10:30 am, 12-1 pm, 7:30-10:30. Wed, 9:30-10:30 am, 12-1 pm. Sun, 11-12 n, 6-7 pm, 7:30-11. Central.

KFQD
Anchorage, Alaska. 344.6m-870kc. 100 watts. Anchorage Radio Club. Announcer, Frank O. Berry. Mon, Fri, 8-10 pm. Sun, 7:30-9 pm. Alaskan time.

KFQU
Holy City, Calif. 249.9m-1200kc. 100 watts. W. E. Riker. Announcer, Arthur J. Landstrom. Daily ex Sun, 6-7:30 pm. Tues, Fri, 9:30-11 pm. Wed, Thurs, Sat, 9-10 pm. Sun, 11-12 n, 9-11 pm. Pacific.

KFQW
Seattle, Wash. 217.3m-1380kc. 100 watts. KFOW, Inc. Pacific. Daily ex Sun, 12-1 pm, 4:30-5:30, 5:30-6, 6-7, 8:30-10, 10-11. Sun, 10-12 n. Pacific.

KFQZ
Hollywood, Calif. 232.4m-1290kc. 100 watts. Taft Radio Company. Announcer, Dave Ward. Daily ex Sun, 12-1 pm, 6-7, 8-11. Sun, 11-12n, 8-11 pm. Pacific.

KFRS
San Francisco, Calif. 454.3m-600kc. 1000 watts. Dun Lee, Inc. Announcer, Harrison Hollway. Daily ex Sat, Sun, 7-9 am, 10-12 n, 12-1 pm, 7:30-12 mid. Sat, 7-9 am, 10-12 n, 12-1 pm, 4-12 mid. Sun, 12-1 am, 12-1 pm, 5-10:30. Pacific.

KFRU
Columbia, Mo. 249.9m-1200kc. 500 watts. Stephens college. Announcer, La Von Rall. Slogan, "Where Friendliness Is Broadcast Daily." Daily ex Sun, 8:30-11:15 am, 3 pm, 6:30. Wed, 7:30-10 pm. Thurs, 7:30-11 pm. Sun, 7:30 am, 9:20, 10:45, 4 pm, 5, 7:30. Founded October 25, 1925. Central.

KFSD
San Diego, Calif. 440.9m-680kc. 500 watts. Airfan Radio Corp. Daily ex Sun, 10-11 am, 6-10 pm. Sun, 11 am, 2-4 pm. Pacific.

KFSG
Los Angeles, Calif. 275.1m-1090kc. 500 watts. Angeles Temple. Daily ex Sun, Mon, 10:30-11:30 am, 11:30-12:30, organ; 2:30-3:30 pm, program; 3:30-4:30, vesper; 6:30-7:30, Tue, 7:30-15 mid. Wed, Fri, 7:30-9:30 pm. Thurs, 7:30-11 pm. Sat, 7:30-9:30 pm. Sun, 10:30 am, 2:30-4:40 pm, 6:30-9:30, 10-11. Pacific.

KFUL
Galveston, Texas. 258.5m-1160kc. 500 watts. Thomas Groggan & Bros.

KFUM
Colorado Springs, Colo. 236.1m-1270kc. 100 watts. Corley Mountain Highway. Announcer, Howard Brown. Mon, Thurs, 6:30-9:30 pm. Tues, 8-9:30 pm. Fri, 8-9 pm. Sat, 6:30-7:30 pm. Sun, 11-12:30 pm, 6:30-8:30. Mountain.

KFVU
St. Louis, Mo. 545.1m-550kc. 500 watts. Concordia Theological Seminary (Lutheran). Announcer, Herm. H. Hohenstein. Mon, 8 pm. Wed, 9:30 pm. Sun, 9:15 pm. Fri, 6:30-7:15 pm. Founded Dec. 14, 1924. Central.

KFUP
Denver, Colo. 227.1m-1320kc. 100 watts. Fitzsimons General Hospital, Educational and Recreational Dept. Daily ex Sat and Sun, 10-11 am. Tues, Thurs, Fri, 7:30 pm. Mountain.

KFUR
Ogden, Utah. 225.4m-1330kc. 50 watts. Peery Building Co. Tues, Thurs, Sat, 9:50-11:50 pm, dance music. Mountain.

KFUS
Oakland, Calif. 256.3m-1170kc. 50 watts. The Gospel Radio. Slogan, "The City of Opportunity." Mon, Wed, Fri, 10-11 am. Wed, Fri, 8-9 pm. Sat, 1:30-2:30 pm, 6:30-7:30. Sun, 9-10 am, 11-12n, 7:45-9 pm, Pacific.

KFUT
Salt Lake City, Utah. 499.7m-600kc. 50 watts. University of Utah.

KFVD
Venice, Calif. 208.2m-1440kc. 250 watts. W. J. & C. I. McWhinnie. Announcer, Leo T. Cleary. Mary Elizabeth Carter. Daily ex Sun, 9:30-12 n, 4:30-6 pm, 9-12 mid. Wed, 12-2 am. Founded Aug. 1926. Pacific.

KFVE
St. Louis, Mo. 234.2m-1280kc. 2000 6 am-6 pm, 1000 watts. Greater St. Louis Broadcasting Corp. Announcer, Thomas Patrick Convey. Daily ex Sun, Thurs, 9:30 am-11 pm, shoppers' club; baseball, studio concert. Thurs, 9:30 am-6 pm. Sun, 11-9 pm. Central.

KFVG
Independence, Kan. 225.4m-1330kc. 50 watts. First Methodist Episcopal church. Slogan, "The Voice of Southeastern Kansas from Independence, the Buckle on the Oil Belt." Tues, 8 pm. Sun, 10:55 am, 8 pm. Central.

KFVI
Houston, Texas. 238m-1260kc. 50 watts. KFVI Broadcasting Company. Announcer, Ted Hills. Daily, 8-9:30 am; 7:10-10 pm. Founded 1925. Central.

KFVS
Cape Girardeau, Mo. 223.7m-1340kc. 50 watts. Hirsch Battery & Radio Co. Announcer, W. W. Watkins. Slogan, "The City of Opportunity." Daily ex Sun, 12:15 pm, news, markets, 7:15, music. Founded July 1925.

KFWB
Hollywood, Calif. 361.2m-830kc. 500 watts. Warner Brothers. Announcer, William "Bill" Ray. Daily ex Sun, 12-2:30 pm. Mon, Tues, 5:15-11 pm. Wed, Sat, 4-11 pm. Thurs, 4:30-11 pm. Fri, 8-9 am, 12:30-3 pm, 5:15-11. Sun, 9-11 pm. Pacific.

KFWC
San Bernardino, Calif. 222.1m-1350kc. 100 watts. L. E. Wall. Announcer, Chester Woods. Daily ex Sun, 4-6 pm, 7-11. Pacific.

KFWF
St. Louis, Mo. 214.2m-1400kc. 250 watts. St. Louis Truith Center. Slogan, "The Voice of Truth." Announcer, Rev. Charles H. Hartmann. Sun, Thurs, 10:45 am, 7:45 pm, 9. Founded 1925. Central.

KFWI
San Francisco, Calif. 267.7m-1120kc. 500 watts. Radio Enterprises, Inc. Announcer, Clara Stixrod. Mon, Tues, Wed, Thurs, 8 am-12 mid. Fri, 7 am-12 mid. Sat, 7 am-2:30 am. Sun, 7:50-12 mid. Pacific.

KFWM
Oakland, Calif. 236.1m-1270kc. 500 watts. Oakland Educational Society. Announcer, G. R. Pollock. Mon, Tues, Thurs, Fri, Sat, 8-10 pm. Thurs, 12:30-1:15 pm. 2-4. Tues, Wed, Fri, 2-3 pm. Tues, 12:30-2:30 pm, 7:30-9 pm. Sun, 9:30-10 am, 12:30-2:30 pm, 7:30-9, 10-11. Pacific.

KFWO
Avalon, Calif. 299.8m-1000kc. 250 watts. Major Lawrence Mott-Signal Corp. Slogan, "Katalin for Wonderful Outings." Daily, 12:30-1:30 pm, 7:30-9. Tues, Fri, Sun, 5-6 pm. Pacific.

KFWV
Portland, Ore. 228.9m-1310kc. 500 watts. KFWV Broadcast Studio. Announcer, Curtis Phillips. Daily ex Sun, 10 am, 6-7 pm, 8-10, 10-11. Pacific.

KFXD
Jerome, Idaho. 204m-1470kc. 15 watts. KFXD Inc.

KFXF
Denver, Colo. 282.8m-1060kc. 500 watts. Colorado Radio Corp. Announcer, W. D. Pyle. Slogan, "The Voice of Denver." Mon, Tues, 6-10 pm. Wed, 6-12 pm. Fri, Sat, 6-12 mid. Sun, 8 pm. Mountain.

KFXJ
Colorado, 215.7m-1300kc. 15 watts. R. G. Howell. Daily ex Sun, 2-4:30 pm, 5:30-9. Sun, 7-7:30 pm. Mountain.

KFXR
Oklahoma City, Okla. 223.7m-1340kc. 50 watts. Exchange Ave. Baptist church. Sun, services.

KFYX
Flagstaff, Ariz. 205.4m-1460kc. 25 watts. Mary M. Costigan. Announcer, Cecil J. Walters. Tues, Thurs, Sat, 10:15-11:15 pm. Mountain.

KFYF
Oxnard, Calif. 238m-1260kc. 25 watts. Carl's Radio Den. Announcer, Carl Newcomb. Slogan, "The Baby Super Station." Daily ex Sun, 5-6 pm. weather, crops, news, music. Pacific.

KFYO
Breckenridge, Tex. 211.1m-1420kc. 15 watts. KFYO Brothers Battery & Elec. Co.

KFYR
Bismarck, N. D. 239.9m-1250kc. 250 watts. Hoskins-Meyer, Inc. Announcer, C. F. Dirlam. Daily ex Sun, 12:30-1:30 pm, 6:30-12:30 mid. Sun, 10:30-12 n, 1-3 pm. Founded Dec. 1925.

KG
Spokane, Wash. 260.7m-1150kc. 2,000 watts. Northwest Radio Service Co. Daily ex Sun, 11 am, 12 news, 12-15, markets, 5:40, stock, weather, 6, time, 6:15, 8, program. Sun, 11 am, 7:30. Pacific.

KGAR
Tucson, Ariz. 234.2m-1280kc. 100 watts. Tucson Citizen. Announcer, Harold S. Sykes. Daily ex Sat, 7-9 pm. Sun, 11 am. Installed June 1926. Mountain.

KGBS
Seattle, Wash. 202.6m-1480kc. 100 watts. Arthur C. Daily, Moore Hotel. Mon, Tues, Wed, Fri, 6:30-10 pm. Thurs, 6:30-10 pm. Pacific.

KGBO
Ketchikan, Alaska. 228.9m-1310kc. 500 watts. Alaska Radio & Service Co.

KG BX
St. Joseph, Mo. 288.3m-1040kc. 100 watts. Foster-Hall, Inc. Announcer, R. D. Foster. Daily ex Sun, 12-1 pm. Wed, 5-7 pm. Tues, Thurs, Fri, 6-10 pm. Founded August 11, 1926. Central.

KG BY
Columbus, Nebr. 202.6m-1480kc. 50 watts. Thelen and Laddiken. Tues, Sat, Fri, 12:35-1:15 pm, 8-9:15. Central.

KG BZ
York, Nebr. 212.6m-1410kc. 100 watts. Announcer, Dr. George R. Miller. Slogan, "Keep Your Hogs and Poultry Healthy." Mon, Wed, Thurs, Fri, Sat, 12:20 am, markets, music, 12:30, 2:30, 7:30. Thurs, Sat, 10:30-11:30 pm, music. Sun, 9 am, service; 3 pm, musicale; Alternate Sun, 5 pm. Opened Aug. 1926. Central.

KG CA
Decorah, Ia. 247.8m-1210kc. 10 watts. Bar Bear Clothing Company. Announcer, Charles Greenley. Daily, 12:30-1 pm. Wed, 7-8 pm. Sun, 2-4 pm. Central.

KG CB
Oklahoma City, Okla. 215.7m-1390kc. 50 watts. Wallace Radio Institute.

KG CH
Wayne, Nebr. 293.9m-1020kc. 250 watts. Wayne Hospital. Announcer, Merrill Shum. Slogan, "Remember Us When U. R. Ill." Daily ex Sun, Mon, 12:45 pm, 6:30 pm. Founded Aug. 1926. Central.

KG CI
San Antonio, Texas. 220.4m-1360kc. 15 watts. Liberty Radio Sales.

KG CL
Seattle, Wash. 230.6m-1300kc. 15 watts. Louis Wasmer, Archie Tait. Announcer, Herman Ricec. Mon, Wed, Thurs, 6:30-7:30 pm, 8:30-11. Tues, Fri, Sat, 3-7:30 pm. Pacific.

KG CN
Concordia, Kan. 208.2m-1440kc. 50 watts. Concordia Broadcasting Co. Daily ex Sun, 12:30-1:30 pm, 7-9. Founded Aug. 1926. Central.

KG CR
Brookings, S. D. 208.2m-1440kc. 15 watts. Cutler's Radio Broadcasting Service, Inc.

KG CU
Mandan, N. D. 208.2m-1440kc. 100 watts. Mandan Radio Assn. Announcer, H. L. Dahners. Daily ex Sun, 12-1:30 pm, 6-7. Sun, 11-12n., 12:30-2:30. Mountain.

KG CX
Vida, Mont. 243.6m-1230kc. 10 watts. First State Bank of Vida. Announcer, E. E. Krebsbach. Daily ex Sun, 12n., Sun, 11 am. Mountain.

KG DA
Dell Rapids, S. D. 254.1m-1180kc. 6 am-6 pm. 15 watts. Home Auto Co. Announcer, Marion Rollins. Sun, 1:30-5 pm. Central.

KG DE
Barrett, Minn. 205.4m-1460kc. 50 watts. Jaren Drug company. Daily ex Sun, 12:30 pm, musicale; 1, 10:30-3 pm, 6.8. Licensed Sept. 15, 1926. Central.

KG DJ
Cresco, Iowa. 202.6m-1480kc. 10 watts. R. Rathert.

KG DM
Stockton, Calif. 217.3m-1380kc. 10 watts. Pepper Co. Daily ex Sun, 10-11:30 am, 2-3 pm. Thurs, Sat, 8-10 pm. Central.

KG DP
Pueblo, Colo. 223.7m-1340kc. 10 watts. Boy Scouts of America. Tues, 8 pm, Thurs, 9 pm. Mountain.

KG DR
San Antonio, Texas. 202.6m-1480kc. 15 watts. Radio Engineers. Announcer, Joe B. McShane. Daily ex Sun, 4:30-5:30 pm. Thurs, 9-10 pm. Central.

KG DW
Humboldt, Nebr. 206.8m-1450kc. 100 watts. Frank J. Rist.

KG DX
Shreveport, La. 212.6m-1410kc. 250 watts. William Erwin Antony.

KG DY
Oldham, S. D. 206.8m-1450kc. 15 watts. J. Albert Loesch. Thurs, 7:45-11 pm. Central. Founded Dec. 26, 1926.

KG EF
Los Angeles, Calif. 263m-1140kc. 500 watts. Trinity Methodist church.

KG EH
Eugene, Ore. 201.2m-1490kc. 50 watts. Eugene Broadcast Station. Daily ex Sun, 9-10 am, 12:15-12:50 pm, 6:30-8. Pacific.

KG EK
Yuma, Colo. 263m-1140kc. 10 watts. Beehler Electrical Equipment Co.

KG EN
El Centro, Calif. 225.4m-1330kc. 15 watts. E. R. Irey and F. M. Bowles.

KG EO
Grand Island, Nebr. 205.4m-1460kc. 100 watts. Hotel Yancey. Mon, Wed, Sat, 8-9 pm. Tues, Fri, 12:25-12:55 pm. Sun, 2-4 pm. Central.

KG EQ
Minneapolis, Minn. 202.6m-1480kc. 50 watts. Fred W. Herrmann. Mon, 7-8 pm. Tues, 8:30-11:45 pm. Wed, 6:30-8:30 pm. Thurs, 8:30-10:30 pm. Fri, 6:15-9 pm. Sat, 3:5-3:30 pm. Central.

KG ER
Long Beach, Calif. 215.7m-1390kc. 100 watts. C. Merwin Dobyns.

KG EU
Lower Lake, Calif. 227.1m-1320kc. 50 watts. Lotowana Lodge. Mon, Wed, Fri, 7-9 pm. Sun, 2:30-3:30 pm, 8-9. Pacific. Founded Dec. 1926.

KG EV
Fort Morgan, Colo. 218.8m-1370kc. 10 watts. City of Fort Morgan.

KG EY
Denver, Colo. 201.2m-1490kc. 15 watts. J. W. Dietz.

KG EZ
Kalispell, Mont. 205.4m-1460kc. 100 watts. Flat-head Broadcasting Assn. Daily ex Sun, 12:30-1:30 pm, 6:30-7:30 pm. Sun, Thurs, 9-11 pm. Sun, 11 am. Mountain.

KG FB
Iowa City, Iowa. 223.7m-1340kc. 10 watts. A. G. Dunkel. Daily ex Sun, 12-12:30 pm, 6-6:30. Mon, Tues, Wed, Thurs, Fri, 11-12 mid. Central.

KG FF
Alva, Okla. 205.4m-1460kc. 25 watts. Earl E. Hampshire.

KG FG
Oklahoma City, Okla. 215.7m-1390kc. 50 watts. Full Gospel Church.

KG FH
La Crescenta, Calif. 223.7m-1340kc. 250 watts. Frederick Robinson.

KG FI
San Angelo, Tex. 220.4m-1360kc. 100 watts. M. L. Eaves. Daily ex Sun, 9 am, 12n., 3 pm, markets, weather, 8-11, entertainment. Central.

KG FJ
Los Angeles, Calif. 208.2m-1440kc. 100 watts. Ben S. McGlashan. Slogan, "Keeping Good Folks Joyful." Daily ex Sun, 6:30-9:30 am, 12-4:30 pm, 6-9. Pacific. Founded Jan. 18, 1927.

KG FK
Hallock, Minn. 223.7m-1340kc. 50 watts. Kittson County Enterprise. Mon, Wed, Fri, 12-1:30 pm. Agri. reports, news, music. Mon, Fri, 8-10:30 pm. Central.

KG FL
Trinidad, Colo. 222.1m-1350kc. 50 watts. Trinidad Broadcasting Co.

KG FM
Yuba City, Calif. 211.1m-1420kc. 15 watts. George W. Johnson.

KG FN
Aneta, N. D. 199. 1500kc. 15 watts. Haraldson & Thingstad.

KG FO
Terre Haute, Ind. m-1470kc. 100 watts. KGFO, Inc.

KG FP
Mitchell, S. D. 212.6m-1410kc. 10 watts. Mitchell Broadcast Co.

KG FW
Ravenna, Nebr. 299.8m-1000kc. 10 watts. Otto F. Sotherman. Announcer R. H. McConnell. Slogan, "Catering to the Home Folks." Daily ex Sun, 8-9 am, 11:45-12:15 pm, 3:15-4:15. Central.

KG FX
Pierre, S. D. 254.1m-1180kc. 200 watts. 6 am-6 pm. Dana McNeil.

KG GF
Picher, Okla. 206.8m-1450kc. 100 watts. Dr. D. I. Connel. Daily ex Sun, 7:30-8:30 pm, 8:30-9:30. Central. On air Sept. 1, 1927.

KG GH
Cedar Grove, La. 212.6m-1410kc. 50 watts. Bates Radio & Elec. Co.

KG O
Oakland, Calif. 384.4m-780kc. 5000 watts. Gen. Elec. Co. Announcer, Howard I. Millholland. Daily ex Sun, 1-1:15 pm, weather, stocks; Daily ex Sun, Mon, 2-3 pm. Daily ex Sun, 5 pm, 5:30, kiddie club; 5:30-6:55, dinner concert. Daily ex Sat, Sun, 6:30-7:30 pm, Agri. program; 6:55-7:30, news, weather, baseball. Mon, Sat, 8 pm, N. B. C.; Mon, 9 pm, book chat. Tues, Wed, Thurs, Fri, 8 pm, studio program; 9, N. B. C. Tues, 10 pm, HM and TP; 10:30, surprise program. Wed, Thurs, Fri, Sat, 10 pm, dance program. Fri, 11:30 am, 11:30. Sun, 11 am, 6:30-7:30 pm. Sat 7-7:30 pm. Pacific.

KG RC
San Antonio, Texas. 220.4m-1360kc. 50 watts. Gene Roth & Co.

KG RS
Amarillo, Texas. 243.8m-1230kc. 150 watts. Gish Radio Service. Announcer, L. B. Cornelius. Daily ex Sun, 6:30 am, 11:45, 6:30 pm. Mon, Wed, Fri, 9 pm, Sun, 11 am, 8 pm. Central.

KG TT
San Francisco, Calif. 206.8m-1450kc. 50 watts. Glad Tidings Temple and Bible Institute. Daily ex Sun, 12:30 pm, scripture reading. Tues, Wed, Fri, 8-10 pm. Wed, 2:30-4 pm, Divine healing service. Sun, 2:30-3 pm, Sunday school, 3-5, service; 7:30-10, service. Pacific. Founded Nov. 1925.

KG U
Honolulu, Hawaii. 270.2m-1110kc. 500 watts. Marion A. Mulrony. Announcer, Homer Tyson. Sun, Mon, Tues, Thurs, Fri, 12-1 pm; 4:30-5:30 pm, 7:30-9, 9:30. 157 1/2 meridian. 2 1/2 hours earlier than Pacific.

KG W
Portland, Ore. 491.5m-610kc. 1,000 watts. Oregon Publishing Co. Announcer, Dick Haller. Slogan, "KGW, Keep Growing Wiser." Daily ex Sun, 10-11:30 am, town crier, household helps; 6-7, concert, 8-9. Mon, 9-10 pm. Tues, 9:45-10 am, exercises; 2-3 pm, 7, travelog; 9-10, 10-12. Wed, 9-10 pm. Thurs, 7:30-7:45 pm, amusement guide; 7:45-8, lecture; 9-10, Fri, 9:45-10 am, exercises; 2-3 pm, 7:30-8, 9-10. Sat, 10-12 mid. Pacific.

KG Y
Lacey, Wash. 243.8m-1230kc. 500 watts. St. Martins College. Announcer, Sebastian Ruth. Slogan, "Out Where the Cedars Meet the Sea." Sun, Tues, Thurs, 8:30-9:30 pm. Pacific.

KH J
Los Angeles, Calif. 405.2m-740kc. 500 watts. Los Angeles Times. Announcer, John S. Daggett. Slogan, "Kindness, Happiness, Joy." Daily ex Sun, Mon, 6 pm, trio; 6:30, children's hour; 7:30, lecture; 8-10, music. Sun, 10 am-12:30 pm, 7, 8-10. Pacific.

KH MC
Harlingen, Tex. 236.1m-1270kc. 100 watts. Harlingen Music Company. Daily ex Sun, 1-3 pm. Mon, Wed, Fri, 7:30-9 pm. Central.

KH Q
Spokane, Wash. 370.2m-810kc. 1000 watts. Louis Wasmer, Inc. Announcer, C. P. Underwood. Slogan, "In the Friendly City." Daily ex Sun, 12:30-1:30 pm, 3-4. Daily ex Sun, Wed, 5-6 pm, 6-7, 8-9, 9-10, 10-12. Wed, 9-10 pm, 10-12. Sun, 10 am, Bible hour; 11-12:30 pm, 2-3:30, 6-7:30, 7:30-9, 9-10. Pacific.

KI AF
Sihtipoc, Minn. 422.3m-710kc. 500 watts. Steele Co. Slogan, "Far from the Maddening Crowd." Mon, Wed, Fri, 7-8 pm. Sun, 2-3 pm. Central.

KI CK
Atlantic, Iowa. 475.9m-630kc. 100 watts. Atlantic Automobile Co. Operated by Walnut Grove Products Co. Announcer, H. A. Marshall. Daily ex Sun, 11:50-12:30 pm, question box, markets. Daily ex Sun, 7:45-9 pm. Founded 1923. Central.

KJ BS
San Francisco, Calif. 220.4m-1360kc. 50 watts. Julius Brunton & Sons Co. Announcer, Jerry Whitaker. Daily ex Sun, 9-11:30 am, 2-4 pm. Fri, 9:30-11 pm. Sun, 2:30-4:30 pm. Pacific.

KJ R
Seattle, Wash. 348.6m-860kc. 2500 watts. Northwest Radio Service Co. Announcer, W. C. Gordon. Daily ex Sun, 10:30 am, shopping service; 11:30, music; 12 n, time, weather; 5:40, stocks; 6, time; 6:10, box office; 6:20, news; 6:30, dinner concert; 8, studio concert; 10, time. Mon, 2 pm, Sun, 11 am, service; 6 pm, dinner concert; 7:45, organ; 8, service; 9:30, studio concert. Pacific.

KK P
Seattle, Wash. 265.3m-1130kc. 15 watts. City of Seattle.

KL CN
Blytheville, Ark. 285.5m-1050kc. 6 am-6 pm. 50 watts. Edgar G. Harris.

KL DS
Independence, Mo. 270.1m-1110kc. 1500 watts. Reorganized Church of Jesus Christ of Latter Day Saints, Midland Broadcasting Co. Announcer, Arthur B. Church. Tues, Fri, 6:30 am. Tues, 6:30 am, 4 pm, 8. Thurs, 4 pm, 8. Sat, 8 pm. Tues, Thurs, Sat, 7 pm. Sun, 8:30 am, 11, 2 pm, 3 pm, 6:30, 9:15. Central.

KL IT
Portland, Ore. 206.8m-1450kc. 10 watts. Lewis I. Thompson.

KL S
Oakland, Calif. 245.8m-1220kc. 250 watts. Warner Bros. Radio Supplies. Announcer, Ralph Moore. Slogan, "The City of Golden Opportunity." Sun, 10-11 am. Pacific.

KL X
Oakland, Calif. 508.2m-590kc. 500 watts. Oakland Tribune. Announcer, Charles H. Gabriel Jr. Slogan, "Where Rail and Water Meet." Daily ex Sun, Mon, 3-5 pm, baseball. Daily ex Sat, Sun, Brother Bob. Mon, 5:30-6:30 pm. Daily ex Sun, 7-7:30 pm, news. Sat, 2-5 pm, football. Wed, Fri, 6:30-7:30 pm, 8-10:30. Pacific. Founded Nov. 20, 1922.

KL Z
Denver, Colo. 267.7m-1120kc. 250 watts. Reynolds Radio Co. Announcer, Doc Reynolds. Slogan, "Pioneer Broadcasting Station of the West." Daily ex Sun, 10-12n., 1-3 pm. Mon, Tues, Wed, 8-10 pm. Fri, 6:30-9 pm. Sat, 9-12 mid. Sun, 9:30-12n., 7-9:30 pm. Mountain.

KMA
Shenandoah, Iowa. 394.5m-760kc. 1000 watts. May Seed & Nursery Co. Announcer, Earl E. May. Daily ex Sun, 5:30-7 am; 9-10, 11-12:30 n, 3-4 pm, 6-9. Sun, 8-9:30 am, 12:15-1:30 pm, 4-5. Central.

KM BC
Kansas City, Mo. 270.1m-1110kc. 1500 watts. Midland Broadcast Central. Announcer, Arthur B. Church. Daily ex Sun, 12 n, 9 pm. Central.

KM ED
Medford, Ore. 249.9m-1200kc. 500 watts. W. J. Virgin. Daily ex Sun, 10-11 am, 12:15-1:15 pm, 6:15. Mon, Tues, Wed, Fri, 10 pm. Thurs, Sat, 11 pm. Sun, 11-12 n, 8-9:15 pm. Pacific. Founded Dec. 22, 1926.

KM IC
Inglewood, Calif. 223.7m-1340kc. 250 watts. J. R. Ponce. Daily ex Sun, 12-2 pm, 5:30-8, 10-12. Sun, 11-12:15 pm, 8-9:15. Pacific. Founded Jan. 10, 1927.

KM J
Fresno, Calif. 365.6m-820kc. 500 watts. Fresno Bee. Announcer, W. F. Bragg. Mon, Wed, Fri, 7:15-9:15 pm. Sat, 9:15-12 mid. Pacific. Founded Oct. 1, 1922.

KM MJ
Clay Center, Nebr. 379.5m-790kc. 790 watts. M. W. Johnson. Co. Daily ex Sun, 8 am, 10, 11, 12: 30, 8. Live stock market; 1:30 pm, 7, 8. Sun, 8:45 pm. Wed, silent. Founded 1925. Central.

KM O
Tacoma, Wash. 254.1m-1180kc. 250 watts. KMO, Inc. Announcer, Carl E. Haymond. Mon, Tues, Wed, Thurs, 10-11 am, 2-3 pm. Mon, 7-9:30 pm. Tues, 9-12:30 am, Wed, Thurs, Fri, 8-10 pm. Sat, 10-11 am, 2-3 pm, 6-7, 9-11. Fri, 10-11 am, 2-3 pm. Sun, 10-13:12 mid., 6-7, 7:30-9. Pacific. Founded Aug. 25, 1926.

KM OX
St. Louis, Mo. 299.8m-1000kc. 5000 watts. The Voice of St. Louis. Announcer, George Junkin. Daily ex Sun, 8:40 am, 1 pm, markets. Daily ex Sun, Thurs, 2 pm, talks, 2:15, baseball; 5:15, music; 5:30, farm talks; 6, children's club; 6:30, orchestra; 7, scores; 8, 9, 10, 11, 12-1 am, music. Sun, 5 pm, 6, 8, 9, 10:30, 11:30, music. Central.

KM TR
Los Angeles, Calif. 526m-570kc. 500 watts. KMTR Radio Corp. Installed June 1925.

KN RC
Santa Monica, Calif. 374.8m-800kc. 500 watts. Keirulff & Ravenscroft Co. Daily ex Sun, Mon, 2:30 pm, hand concert; 3, 3:15, 5, 6, 7, 8, 10. Tues, Sat, 2 pm. Sun, 10:45-11:45 am, 2:30-4 pm, 6:15-7, 7-8, 8-9, 9-10. Installed 1921. Pacific.

KN X
Hollywood, Calif. 336.9m-890kc. 500 watts. Los Angeles Evening Express. Announcer, "Town Crier." Daily ex Sun, 6:45 am, exercises; 8, prayer; 8:55, time; 9, news; 10, Town Crier; 10:30, economics; 1:30 pm, 1:30 pm, talk; 2-4, 4-55, markets; 5, 5:30, music; 5:45, Town Crier; 6:30, dinner music. Mon, Tues, Wed, Thurs, Fri, 7-12 midnight. Sat, 7-2 am. Sun, 10-12:30 pm, church service; 12:45-1:45, 2-4, 6:30-9, 9-10:30. Installed Oct. 11, 1924. Pacific.

KO A
Denver, Colo. 325.9m-920kc. 10000 watts. 6 am-7 pm. General Elec. Co. Daily ex Sun, 11:45 am, weather, road reports, markets. Daily ex Sat, Sun, producer. Daily ex Sun, 12:05 pm, organ. Tues, Thurs, Fri, 4, housewives' matinee. Tues, Thurs, Fri, 3:30 pm. Daily ex Sat, Sun, 6 pm, stocks, markets, produce, news bulletins. Mon, 7:30 pm. Tues, farm question box. Wed, 7:30 pm, Tiny Town tales; Fri, 7:30 pm, S. S. lesson. Mon, Wed, Fri, 8 pm, orchestra; 8:15 pm, regular program. Sat, 7 pm, football. Sun, 11 am and 7:30 pm, service; 5 pm, music. Founded Dec. 15, 1924. Mountain.

KO AC
Corvallis, Ore. 270.1m-1110kc. 500 watts. Oregon Agricultural College. Announcer, W. G. Kaddery. Mon, Wed, Thurs, Fri, 7 pm. Pacific.

KO B
State College, N. M. 394.5m-760kc. 5000 watts. N. M. College of Agri. & Mech. Arts. Announcer, Robert Stewart. Slogan, "The Sunshine State of America." Daily 11:55-12:30 pm, time, weather, markets, road reports, news; 9:55-10:10, time, weather, road reports. Mon, 7:30-8:30, pm, farm program. Wed, Fri, 7:30-8:30 pm, music. Founded 1921. Mountain.

KO CH
Omaha, Nebr. 258.5m-1160kc. 250 watts. Central H. S. Announcer, C. H. Thompson. Mon, Tues, Thurs, 7:10-8 pm, Sat, 12 midnight. Sun, 3:30 pm. Founded 1922. Central.

KO CW
Chickasha, Okla. 252m-1190kc. 250 watts. Okla. College for Women. Tues, Thurs, 8 pm, music. Daily ex Sun, 12-1:30 pm, Sun, Mon, Wed, Thurs, 10:15 am, Mon, 10-1:30 am, musicale. Central.

KO IL
Council Bluffs, Ia. 277.6m-1080kc. 4000-2000 watts. Mosa Motor Oil Co. Announcer, Bob Hall. Daily ex Sat, Sun, 11:45 am, music, talks; weather, markets; 12, music; 1, "Aunt Sammy." Daily ex Wed, Sun, 5:50, weather, news; 6-12 mid. Sat, 12-12:30 am, 1 pm. Sun, 11 am, service; 12:15, Uncle Jack; 7, 7:30, 11. Founded July 10, 1925. Central.

KO IN
Portland, Ore. 319m-940kc. 1000 watts. KOIN, Inc. Daily ex Sun, 11 am, 12 n, 3, 6, 7, 7:30, 8. Sun, 6-7 am, 7:50, 9. Pacific.

KO MO
Seattle, Wash. 305.9m-980kc. 1000 watts. Fisher's Blend Station, Inc. Announcer, G. Donald Gray. Daily ex Sun, 10 am-12:30 am, 10, inspirational; 10:15, health exercises; 10:30, home economics; 11, vocalists; 12 n, farm talks; 12:15, organ; 1:15, orchestra; 5:15, children's program; 5:45, stocks and bonds; 6, news; 6:15, orchestra; 9, N. B. C.; 10, program; 10:30, news; 10:45, dance orchestra. Pacific.

KO W
Denver, Colo. 475.9m-630kc. 250 watts. The Associated Industries Broadcasting. Announcer, Lewis Grove. Daily ex Sun, 11 am-12 n, 1:30-3:30 pm, 6:30-10. Sun, 11 am, 6, service. Mountain.

KO WW
Walla Walla, Wash. 299.9m-1000kc. 500 watts. Frank A. Moore. Slogan, "The Valley They Liked So Well They Named It Twice." Mon, Thurs, 4-5 pm, 7-12. Tues, 4-5 pm, 7-8. Wed, 4-5 pm, 7-9:30. Fri, 4-5 pm, 7-10. Sat, 7-8 pm, 10-12. Sun, 11-12 n. Pacific.

KP CB
Seattle, Wash. 230.6m-1300kc. 500 watts. Pacific Coast Biscuit Co. Daily ex Sun, 11:15-11:30 am, recipe; 11:30-12 n, musicale. Mon, Wed, Thurs, 5:30-6 pm, 6-6:30 pm. Tues, Fri, 8:30-9:30 pm. Mon, 7:30-8:30 pm, 9:30-10:30. Tues, 9:30-10:30 pm. Wed, 7:30-8:30 pm. Thurs, 7:30-8:30 pm. Fri, 7:30-8:30 pm, 9:30-10:30. Sat, 7:30-10:30 pm. Pacific. Founded April 1, 1927.

KP JM
Prescott, Ariz. 214.2m-1400kc. 15 watts. Frank Wilburn. Irregular hours, news, sports.

KP LA
Los Angeles, Calif. 252m-1190kc. 500 watts. Bert-ram O. Heller. Slogan, "Rim of World Station." Daily ex Sun, 5 pm, 8, news, weather, road reports. Pacific.

KP NP
Muscatine, Iowa. 211.1m-1420kc. 100 watts. Central Radio Co.

KP O
San Francisco, Calif. 422.3m-710kc. 1000 watts. Hale Bros. and the Chronicle. Announcer, Curtis Peck. Slogan, "The Voice of San Francisco, The City by the Golden Gate." Daily ex Sun, 6:45-7:15, 7:45, health drills; 10:30, utility features; 12 n, time, weather. Daily ex Sun, 1-7:30 pm, concert, talks. Mon, Tues, Wed, Thurs, Fri, 8-12 mid. Sat, 8-1 am. Fri, 12:45 pm, luncheon talks. Mon, 12-1 pm. Sun, 2:40 pm, orchestra; 6-10 mid, concert. Pacific.

KP PC
Pasadena, Calif. 228.9m-1310kc. 500 watts. Pasadena Presbyterian church. Wed, 7-9 pm. Sun, 9:45-12:45 pm, 6:45-9. Founded Dec. 25, 1924. Pacific.

KP RC
Houston, Texas. 293.9m-1020kc. 500 watts. Houston Post-Dispatch. Slogan, "Kotton Port Rail Center." Announcer, Alfred P. Daniel. Daily ex Sun, 10:55 am, time; 11, weather, markets; 12 noon, entertainment. Daily ex Fri, Sun, 3-4 pm. Daily ex Sun, Fri, 7:30-9:30 pm. Sun, 8 pm, service; 9:30-10:30 pm, music. Founded May 8, 1925. Central.

KPSN

Pasadena, Calif. 315.6m-950kc. 1000 watts. Pasadena Star-News. Announcer, George Frenger. Daily ex Sun, 12:15 pm, 6 pm, news. Tues, Thurs, Sat, 8-9 pm. Sun, 10:30-12:30 am. Installed Nov. 23, 1925. Pacific.

KQV

Pittsburgh, Pa. 270.1m-1110kc. 500 watts. Doubleday-Hill Elec. Co. Announcer, Howard E. Clark. Mon, Wed, Fri, 4-5 pm, 6-9. Tues, Thurs, 4-5 pm, 6-7. Sun, 1-2 pm. Eastern.

KQW

San Jose, Calif. 296.9m-1010kc. 500 watts. First Baptist church. Daily ex Sun, 6:30-6:50 pm, markets; 7-8, farm news; 7, weather; 7:05, news; 7:20, farm topics; 7:30, mail bag; 7:40, editorial; 7:55, riddles. Mon, Fri, 8-9 pm. Sun, 10:15 am, 7:30, service. Wed, 8-9:30, service. Pacific.

KRAC

Shreveport, La. 220.4m-1360kc. 50 watts. Caddo Radio Club. Announcer, Dr. Le Roy Scott.

KRE

Berkeley, Calif. 256.3m-1170kc. 100 watts. First Congregational Church of Berkeley.

KRLD

Dallas, Texas. 461.3m-650kc. 500 watts. KRLD, Inc. Announcer, Arthur W. Stowe. Slogan, "Where the Bluebonnets Grow." Daily ex Wed, Sun, 12:30-1:30 pm, 7-8:30, 9:30-10:30. Mon, 11-12 mid. Tues, 8:30-9 pm. Thurs, 8-9 pm. Sat, 11-12 mid, organ. Central. Founded Oct. 30, 1926.

KRLO

Los Angeles, Calif. 215.7m-1390kc. 250 watts. Freeman Lang, A. B. Scott.

KRSC

Seattle, Wash. 211.1m-1420kc. 50 watts. Radio Sales Corp. Announcer, William J. Calsamalia. Daily ex Sun, 9-10 am, 6-7:30 pm, 9-10:30 pm. Mon, Wed, Fri, 3:30-5 pm. Pacific.

KSAC

Manhattan, Kan. 333.1m-900kc. 500 watts. Kansas State Agricultural College. Announcer, George Gemmill. Daily ex Sat, Sun, 9-10 am, 9:55, 12:35 pm, 4, 7. Sat, 12:35 pm. Central.

KSBA

Shreveport, La. 267.7m-1120kc. 1000 watts. Shreveport Broadcasting Assn. Announcer, W. G. Patterson. Daily ex Sun, 9:15 am, 12:15 pm, 2:15, market, news, weather. Tues, Wed, Thurs, Fri, 6:30 pm, 8. Tues, 11 pm, Sat, 9 pm. Sun, 11 am, 8 pm, services. Central. Founded Dec. 1, 1924.

KSCJ

Sioux City, Iowa. 243.8m-1230kc. 500 watts. Perkins Brothers Co. Daily ex Sun, 9:45 am, 10:45, 12:15, stock, markets, weather; 11:30-12:30 pm, news, music; 1:45-3:45 pm. Mon, Tues, Wed, Fri, 6 pm. Sun, 11 am, 7:45 pm, service; 2-4, musicale. Central.

KSD

St. Louis, Mo. 545.1m-550kc. 500 watts. St. Louis Post-Dispatch. Announcer, W. P. Corwin. Daily ex Sun, 9:40 am, 10:40, 11:40, 12:40, 2:40, Mon, 9:30-10:30 pm, Tues, 7-9 pm. Wed, 7-8:30 pm, Thurs, 6-7 pm. Fri, 6-8:30 pm. Sun, 5:20-7:45 pm. Central. Founded June 24, 1922.

KSEI

Pocatello, Idaho. 333.1m-900kc. 250 watts. KSEI Broadcasting Assn. Announcer, W. J. O'Connor. Daily ex Sun, 3-4 pm, 6-8, 9-11. Sun, 9-11 pm. Mountain.

KSL

Salt Lake City, Utah. 392.8m-990kc. 1000 watts. Radio Service Corp. of Utah. Announcer, Roscoe Grover. Daily ex Sun, 7:30 pm. Mon, Wed, 7:30 am, 7:45, 8. Mon, 6:30 pm, 7:15, 7:30, 8, 8:30. Tues, 7 pm, 7:15, 7:30, 8, 9. Wed, 10 am, 6:15 pm, 6:30, 7, 7:30, 8:30, 9:30. Thurs, 7 pm, 7:30, 8, 8:30, Fri, 7:15 am, 10, 6:30 pm, 7:15, 7:30, 8, 9. Sat, 7:15 pm, 7:30, 10. Sun, 11 am, 3 pm, 5, 7:30, 9, 10. Mountain.

KSMR

Santa Maria, Calif. 272.6m-1100kc. 100 watts. Santa Maria Valley Railroad Company. Announcer, Sydney C. Peck. Daily ex Sat, Sun, 6:30-9:30 pm. Sat, 7:30 pm, markets. Pacific.

KSO

Clarinda, Iowa. 227.1m-1320kc. 500 watts. Berry Seed Co. Announcer, Joe Paassen. Slogan, "Keep Serving Others." Daily ex Sun, 6-7 am, 12-1 pm, talks. Daily ex Sat, Sun, 6:30-9 pm. Sun, 11-12 n. Founded Nov. 2, 1925. Central.

KSOO

Sioux Falls, S. D. 209.7m-1430kc. 250 watts. Sioux Falls Broadcast Assn.

KTAB

Oakland, Calif. 280.2m-1070kc. 500 watts. The Associated Broadcasters. Announcer, Lytton Spaulding. Daily ex Sun, 8:45-9:15 am, prayer service; 9:15-10, shopping hour; 7-7:30 pm, shopping hour. Mon, Tues, Wed, Thurs, 6:30-7 pm, twilight hour. Mon, Tues, Wed, Thurs, Fri, 8-10 pm, entertainment. Daily ex Sun, Sat, 5-6 pm. Sun, 10 am, 11-7:45 pm. Pacific.

KTAP

San Antonio, Tex. 228.9m-1310kc. 20 watts. Robert B. Bridge, Alamo Broadcasting Co. Daily ex Sun, 6:30-7:30 am, 10:30-11:30, 12:30-2 pm, 6:30-8, 9:30-10:30. Mon, silent. Sun, 4-6 pm, 9:30-10:30. Central.

KTBI

Los Angeles, Calif. 288.3m-1040kc. 500 watts. Bible Inst. of Los Angeles. Announcer, H. P. Herdman. Daily ex Sun, 8:45 am, 2 pm, 7:15-9. Sun, 10:45 am, 6, 6 pm, 7:15, 9:30. Pacific.

KTBR

Portland, Ore. 282.8m-1060kc. 50 watts. M. E. Brown. Pacific.

KTCL

Seattle, Wash. 277.6m-1080kc. 500 watts. American Radio Telephone Co.

KTHS

Hot Springs National Park, Ark. 384.4m-780kc. 1000 watts. The Arlington hotel. Announcer, G. C. Amoux. Slogan, "Kum to Hot Springs." Mon, C. Wed, Thurs, Fri, 12-1 pm, 8:30-10:30 pm. Tues, 12-1 pm, 6-8:30. Fri, 12-1 pm, 6:30-8:30, 12-1 am. Sun, 11 am, 8:30-10:30 pm. Installed Dec. 20, 1924. Central.

KTNT

Muscantine, Iowa. 256.3m-1170kc. 5000 6 am-6 pm, 3500 watts. Norman Baker. Slogan, "The Home of the Gallophone and Voice of the Iowa Farm Union." Announcer, Adam Reinemund. Daily ex Sun, 6 am, 8:30 pm. Daily ex Sun, Sat, 8-10 pm. Sun, 12 n, 2:30 pm, 8. Founded 1924. Central.

KTSA

San Antonio, Tex. 265.3m-1130kc. 2000 watts. Alamo Broadcasting Co.

KTUE

Houston, Tex. 212.6m-1410kc. 5 watts. Uhalt Electric. Announcer, Bill Arnold. Daily ex Sun, 5:15-6:15 pm. Tues, 8-9 pm, Sat, 8-9:30 pm. Central.

KTW

Seattle, Wash. 394.5m-760kc. 1000 watts. First Presbyterian church. Announcer, I. D. Ross. Slogan, "Hear Ye, Hear Ye, the Gospel." Sun, 11-12:30 pm, 3-4:30, 7-9:30, church service. Pacific.

KUJ

Seattle, Wash. 199.9m-1500kc. 50 watts. Puget Sound Radio Broadcasting Co. Mon, Wed, Fri, 6-9 pm. Sat, 6-12 mid. Pacific.

KUOA

Fayetteville, Ark. 296.9m-1010kc. 500 watts. University of Arkansas. Sun, Mon, 7:30-9 pm. Thurs, 7:30-9 pm. Central.

KUOM

Missoula, Mont. 374.8m-800kc. 500 watts. University of Montana. Three days a week.

KUSD

Vermillion, S. D. 483.6m-620kc. 250 watts. University of South Dakota. Announcer, C. J. Cosandey. Slogan, "South Dakota University for South Dakotans." Wed, 7:30-8:30 pm. Tues, 6:45-7:30 pm. Sun, 9-10 pm. Central.

KUT

Austin, Tex. 232.4m-1290kc. 500 watts. University of Texas. Announcer, Orlando J. Murphy. Mon, Wed, 8 pm, Fri, 8 pm, Sun, 11 am, 7:30 pm. Founded 1925. Central.

KVI

Tacoma, Wash. 234.2m-1280kc. 50 watts. Puget Sound Radio Broadcasting Co. Daily ex Sun, 8-10 am. Wed, Fri, Sat, 6:15-9 pm. Sun, 11-12:30 pm, 1:30-3:30, 3:30-4:30, 4:30-5:30, 7:30-9. Pacific.

KVOO

Bristow, Okla. 348.6m-860kc. 1000 watts. Southwestern Sales Corp. Daily ex Sun, 8-9 am, 11, markets, 11:30, 12:30, 1:30-2:30, 2:45, 3-4, 5:30, children's hour; 6-9, 12 mid, music. Fri, 11 pm, dance. Sun, 9:15 am, Bible class; 1-2 pm, music; 5-6, 6-7, 7-9, church service; 12 mid, music. Central.

KVOS

Seattle, Wash. 209.7m-1430kc. 50 watts. Voice of Seattle.

KWBS

Portland, Ore. 199.9m-1500kc. 15 watts. Schaeffer Radio Co.

KWCR

Cedar Rapids, Iowa. 352.7m-850kc. 250 watts. Announcer, H. F. Paar. Slogan, "The Voice of Cedar Rapids." Daily ex Sun, 6:30 am, 11:30, 4, 5:30 pm. Mon, Wed, 9:15 pm, Fri, 10 pm. Sun, 11 am, 5:45 pm, 9:30. Central.

KWG

Stockton, Calif. 344.6m-870kc. 50 watts. Portable Wireless Telephone Co. Announcer, George J. Turner. Slogan, "Voice of the San Joaquin Valley." Daily ex Sun, 4-5 pm, news, concert, markets. 5-6 pm, 6-7:30, 8-10, concert. Wed, Thurs, Sat, 10-11 am, dance music. Sun, 9:30-10:30, organ. Pacific.

KWJJ

Portland, Ore. 228.9m-1310kc. 50 watts. Mon, Tues, 3-4:30 pm, 6-10. Wed, 6-12 mid, Thurs, 6-11 pm, Fri, 6-10 pm. Sat, 6-8 pm, Sun, 12-1 pm, 8-9. Pacific.

KWKC

Kansas City, Mo. 222.1m-1350kc. 100 watts. Wilson Duncanson Studios. Announcer, Elmer C. Hodges. Slogan, "Keep Watching Kansas City." Tues, Wed, Thurs, Fri, 7 pm, 9. Central.

KWKH

Shreveport, La. 394.5m-760kc. 1000 watts. Henderson Iron Works & Supply Co. Daily and Sun, 9-12 mid. Central. Founded Jan. 8, 1925.

KWLC

Decorah, Iowa. 247.8m-1210kc. 50 watts. Luther College.

KWSC

Pullman, Wash. 394.5m-760kc. 500 watts. State College of Washington. Mon, Wed, Fri, 7:30-9 pm, music, lectures. Pacific.

KWTC

Santa Ana, Calif. 352.7m-850kc. 5 watts. Dr. John Wesley Hancock. Mon, 6:30-7:45 pm. Tues, 6:30-10 pm. Wed, 6:30-7:30 pm. Thurs, 6:30-10 pm. Fri, 6:30-8 pm. Sat, 6:30-9:30 pm. Pacific.

KWU

Le Mars, Iowa. 243.8m-1230kc. 1500 watts. Western Union College. Announcer, Rex Froelker. Daily ex Sun, 9:30 am, 11:15, markets; 12:30-1:30 pm, 4-5. Daily ex Thurs, Sun, 7-8 pm. Sat, 10-12 mid. Central. Founded 1922.

KWWG

Brownsville, Texas. 277.6m-1080kc. 500 watts. Brownsville Chamber of Commerce. Slogan, "Kum to the World's Winter Garden." Daily ex Sun, 12 m, 6 pm. Mon, Thurs, 8:30-11:59 pm. Central.

KXL

Portland, Ore. 220.4m-1360kc. 50 watts. KXL Broadcasters. Announcer, A. R. Truitt. Slogan, "Entertainment, Education." Daily ex Sun, 9-10 am, 6-11 pm. Sun, 9 am-6 pm. Pacific.

KXRO

Aberdeen, Wash. 227.1m-1320kc. 50 watts. KXRO, Inc.

KYA

San Francisco, Calif. 309.1m-970kc. 500 watts. Pacific Broadcasting Corp. Announcer, Edward J. Ludes. Daily ex Sun, 7-8 am, 10-12 n, 12:30-2 pm, 5:30-7:30, 8-10. Tues, Fri, 10:30 am, diet talk. Pacific. Founded Dec. 18, 1926.

KYW

Chicago, Ill. 526m-570kc. 2500 watts. Westinghouse Elec. & Mfg. Co. Announcer, John Clark. Daily ex Sun, 10:55, time; 5:30 pm, baseball; 5:45, markets; 6, bedtime story; 6:30, dinner concert; 7-9, WJZ; 9-10:30, program; 10:30, weather; 10:32, orchestra, Congress Carnival; 11:55, time, weather; Sun, 10:25, time, weather; 1 pm, WJZ; 5:30, reading; 7:30, WJZ; 9:30-10:30, program; 10:30, weather; 10:55, weather, time. Central.

KZIB

Manila, P. I. 249.9m-1200kc. 20 watts. I. Beck, Inc. Daily, 8:30-10:30 pm.

KZM

Oakland, Calif. 245.8m-1220kc. 100 watts. Western Radio Institute (Hotel Oakland). Announcer, Elbert Cowan. Daily ex Sun, 6:30-7:30 pm. Sun, 8-10 pm. Pacific. Founded June 29, 1921.

KZRN

Manila, P. I. 413m-726.1kc. 500 watts. Radio Corp. of Philippines.

KZRQ

Manila, P. I. 400m-750kc. 500 watts. Radio Corporation of the Philippines. Slogan, "Radio Manila."

NAA

Washington, D. C. 434.5m-690kc. 1000 watts. United States Navy Dept. Daily 10:05 am, 3:45 pm, weather. Daily 12 n, 10 pm, time. Eastern.

WAAD

Cincinnati, Ohio. 267.7m-1120kc. 25 watts. Ohio Mechanics Institute. Sat, 9:45 pm. Eastern.

WAAF

Chicago, Ill. 389.4m-770kc. 500 watts. Chicago Daily Drivers Journal. Announcer, Carl Ulrich. Daily ex Sun, 8:45 am, 10:50, 11, 12:50 pm. Daily ex Sun, Sat, 4:30, live stock and weather reports. Central. Founded May 22, 1922.

WAAM

Newark, N. J. 348.6m-860kc. 500 watts. I. R. Nelson Company. Announcer, Jack Van Riper. Daily ex Sun, 7-8 am, 11-1:30 pm, 4-6. Mon, Wed, Fri, 7-12:30 am. Tues, Thurs, Sat, 6:30-7:30 pm. Eastern. Experimental call 2XBA 65.18m.

WAAT

Jersey City, N. J. 245.8m-1220kc. 300 watts. Bremer Broadcasting Corp. Announcer, Randolph Conroy. Slogan, "The Voice at the Gate of the Garden State." Daily ex Sun, 10:30 am, housewives' hour; 6 pm, markets; 6:05, dinner music; 6:40, weather; 6:45, sports; 7, time. Mon, Thurs, Sat, 8-11 pm. Tues, 8-9 pm. Sun, 5:30 pm, 6, 7, time; 7:30, quartet; 8, program. Eastern. Founded Nov. 20, 1926.

WAAW

Omaha, Nebr. 348.6m-860kc. 500 watts. Omaha Grain Exchange. Announcer, James Thompson. Slogan, "Pioneer Market Station of the West." Daily ex Sun, 8:30 am, 8:45, 9:15, 9:45, 10:15, 10:45, 11:15, 11:45, 12:15, 1:15, 1:35, 1:40, 8, 8:30, Daily ex Sat, Sun, 1:30-3:30 pm. Daily ex Wed, Sun, 7-9 pm. Founded 1921. Central.

WABC

Richmond Hill, N. Y. 325.9m-920kc. 2500 watts. Atlantic Broadcasting Corp. Mon, Wed, Fri, 7:30-1 pm. Eastern.

WABF

Kingston, Pa. 205.4m-1460kc. 250 watts. Markle Broadcasting Corp. Announcer, E. L. Jones. Slogan, "The Voice of Wyoming Valley." Daily ex Sun, 12-1 pm. Mon, Wed, Fri, 7-9 pm. Sun, 9:30-10:30 am, 10:30-12, 7:30-9. Eastern.

WABI

Bangor, Me. 389.4m-770kc. 100 watts. First Universalist church. Announcer, Prof. W. J. Creamer, Jr. Sun, 10:30 am, 7:30-9 pm. Eastern.

WABQ

Philadelphia, Pa. 260.7m-1150kc. 500 watts. Keystone Broadcasting Co. Haverford college. Hotel Lorraine. Mon, 6-11:30 pm. Tues, 6-12:30 am. Wed, 6-11:30 pm. Thurs, 6-11:30 pm. Fri, 6-12:30 pm. Sat, 6:30-11:30 pm. Sun, 8-11:30 pm. Eastern.

WABW

Wooster, Ohio. 247.8m-1210kc. 50 watts. The College of Wooster, Dept. of Physics. Announcer, Frank C. Isely.

WABY

Philadelphia, Pa. 247.8m-1210kc. 50 watts. John Magaldi, Jr. Slogan, "Quaker City Sleep Dodgers." Club, "The American Broadcasting Club." Sun, 9 pm, music; 10:30, "Sleep Dodgers" session." Eastern.

WABZ

New Orleans, La. 247.8m-1210kc. 50 watts. The Coliseum Place Baptist church. Announcer, Charles B. Slogan. Slogan, "The Station with a Message." Sun, 11-12:15 pm, 7:30-8:45, church service. Central. Founded January, 1924.

WADC

Akron, Ohio. 296.9m-1010kc. 1000 watts. Allen Theater Broadcasting Station. Announcer, George F. Houston. Daily ex Sun, 11-12 noon, 5:30-6 pm. Mon, Wed, Fri, 8-11 pm. Tues, 9-10 pm. Thurs, 8-11 pm. Sun, 10:30-11:45 am, 12:30-1:30 pm, 3-5, 9-11. Eastern.

WAFD

Detroit, Mich. 243.8m-1230 kc. 100 watts. Albert B. Parfet Co. Announcer, Stanley G. Smith. Slogan, "Gateway to the Great Lakes." Mon, 8-12 mid. Wed, Fri, 8-10 pm. Sat, 12 mid. Sun, 10:30 am; 7:30 pm. Eastern.

WAGM

Royal Oak, Mich. 225.4m-1330kc. 50 watts. Robert Miller. Announcer, R. L. Miller. Mon, 8-12:30 am. Wed, Fri, 8-10:30. Founded Oct. 3, 1925. Central.

WAGS

Lexington, Mass. 215.7m-1390kc. 5 watts. J. Smith Dodge, Carl S. Wheeler. Daily ex Sat, Sun, 8:30-10:30 pm. Sat, 11 pm. Sun, 3-4 pm, 8:30-10:30. Eastern. Founded Oct., 1926.

WAIT

Taunton, Mass. 214.2m-1400kc. 10 watts. A. H. Waite & Co., Inc. Off the air until October.

WAIU

Columbus, Ohio. 282.8m-1060kc. 5000 watts. American Insurance Union. Announcer, Don Bernard. Daily ex Sun, 10:30 am, 10:55, time, 12-1 pm, music, news, markets, weather. Daily ex Sat, Sun, 2-4 pm, stock, music. Mon, Tues, Wed, Thurs, 6-7 pm. Fri, Sat, 6-7 pm. Mon, Fri, 7-12 mid. Tues, Sat, 10-12 mid. Eastern.

WALK

Willow Grove, Pa. 201.2m-1490kc. 50 watts. Albert A. Walker, portable.

WAMD

Minneapolis, Minn. 225.4m-1330kc. 500 watts. Radisson Radio Corporation. Stanley E. Hubbard. Slogan, "The Call of the North." Daily ex Sun, 10:30 am, musicale; 11, shopping news; 12, weather; 12:01, pm, organ; 5, readers' club; 5:30, musical moments; 5:45, news; 5:50, baseball; 5:58, time; 6, What's Doing Tonight; 6:03, fishing reports; 6:05, financial news; 6:15, dinner concert; 7, musicale; 10:45, musicale; Sun, 5:50 pm, baseball; 5:55, What's Doing; 6, dinner concert; 9:45, request program. Central.

WAPI

Auburn, Ala. 319m-940kc. 1000 watts. Alabama Polytechnic Institute. Announcer, W. A. Young. Daily ex Sun, 12-1, 7-7:15 pm. Tues, Thurs, Fri, 9-10 pm. Installed 1922. Central.

WARS

Brooklyn, N. Y. 227.1m-1320kc. 500 watts. Amateur Radio Specialty Co. Daily ex Sun, 4 pm, 12 mid. Sun, 12:30-3 pm. Eastern.

WASH</

WBZ

Springfield, Mass. 333.1m-900kc. 15000 watts. Westinghouse Elec. & Mfg. Co. Announcer, Aidan Redmond. Daily ex Sun, 10:30 am, organ; 10:45, household hints; 11:20, weather; 6:27 pm, baseball; 6, organ; 6:30-10:30, 10:30, baseball, weather. Sun, 2 pm, WJZ; 7:30, baseball, weather; 7:45, music; 10:50, weather. Installed Sept. 19, 1921. Eastern.

WBZA

Boston, Mass. 333.1m-900kc. 500 watts. Westinghouse Elec. & Mfg. Co. Same programs as WBZ.

WCAC

Mansfield, Conn. 535.4m-560kc. 500 watts. Connecticut Agricultural College. Announcer, Daniel E. Noble. Slogan, "From the Nutmeg State." Daily, 7:15-8 pm. Sat, 7:30-8:30 pm. Eastern. Founded June 1923.

WCAD

Canton, N. Y. 365.6m-820kc. 500-1000 watts. St. Lawrence University. Announcer, Ward C. Priest. Slogan, "The Voice of the North Country." Daily, 12:30 pm, weather, reports, talks, music, time. Wed, 8 pm. Eastern.

WCAE

Pittsburgh, Pa. 516.9m-580kc. 500 watts. Pittsburgh Press. Daily ex Sun, 6:45-8 am, exercises; 8:15, 9:15, 10:15, 12:15, 2:15 pm, 5:15; 1:30, 3:40 pm, news; 2:30 pm, organ; 6, dinner music; 7, popular music; 5:30, 7:30, Uncle Kay Bee; 8-10, Sun, 6 pm, 7:15-10, WEA. Eastern.

WCAH

Columbus, Ohio. 535.4m-560kc. 250 watts. Entering Elec. Co. Tues, 8-10:30 pm. Sun, 10:30 am, 12 n, 7:30-9 pm. Every other Sun, 4 pm. Eastern.

WCAJ

University Place, Nebr. 379.5m-790kc. 500 watts. Nebraska Wesleyan University. Announcer, J. C. Jensen. Daily, 10 am, convocation exercises; 4:30 pm, weather, news. Tues, Fri, 12 n, organ. Tues, 7:30 pm, Bible study; Wed, 8 pm, class; 9 pm, music. Sun, 11 am, services; 4 pm, vesper. Founded Oct., 1921. Central.

WCAL

Northfield, Minn. 236.1m-1270kc. 500 watts. Dept. of Physics, St. Olaf College. Announcer, Hector Skifter. Slogan, "The College on the Hill." Daily ex Sun, 9:45 am, Mon, 7 pm; 8:15, Sun, 8:30-9:30 am; 3-4 pm. Central. Founded, 1922.

WCAM

Camden, N. J. 223.7m-1340kc. 500 watts. City of Camden. Announcer, Harry E. Ehrhart. Mon, Wed, Fri, 7:30-10:30 pm. Eastern. Founded Oct. 26, 1926.

WCAO

Baltimore, Md. 384.4m-780kc. 250 watts. Monumental Radio, Inc. Announcer, Wm. L. Atkinson. Mon, Wed, Fri, 6-11 pm. Sun, 11-12 n, 3-5, 9-11. Eastern.

WCAT

Rapid City, S. D. 247.8m-1210kc. 100 watts. South Dakota State School of Mines. Announcer, J. O. Kammerman. Daily ex Sun, 9:30 am, 12:30 pm, weather, reports. Thurs, 7:30 pm, concert. Mountain.

WCAU

Philadelphia, Pa. 336.9m-890kc. 500 watts. Universal Broadcasting Co. Announcer, Stan Lee Broza. Slogan, "Where Cheer Awaits U." Mon, 5:30-11:30 pm. Tues, 5-11:30 pm. Wed, 5:30-12 mid. Thurs, 5:30-12 mid. Fri, 5:30-11 pm. Sat, 6:30-11. Sun, 2-11 pm. Eastern.

WCAX

Burlington, Vt. 254.1m-1180kc. 100 watts. University of Vermont. Slogan, "The Voice of the Green Mountains." Fri, 7-8 pm. Eastern.

WCAY

Carthage, Ill. 340.7m-880kc. 50 watts. Carthage College. Announcer, Raymond Berke. Daily ex Sun, 7:40-12:15 pm. Mon, Wed, 7-8 pm. Central.

WCBA

Allentown, Pa. 222.1m-1350kc. 100 watts. Queen City Radio station. Wed, 8:15-11 pm. Fri, 7:30-10:30 pm. Sat, 10-11 pm. Dance music. Sun, 10 am, 5:30 pm, 7, church service. Eastern.

WCBD

Zion, Ill. 344.6m-870kc. 5000 watts. Wilbur Glenn Vivian. Announcer, H. DePew. Slogan, "Where God Rules, Man Prospers." Tues, Thurs, 9-11:30 pm, concert. Wed, 1:30-2 pm, organ. Thurs, 2:30-3:45 pm, service. Sun, 9-10:45 am, Bible school; 2:30-6 pm, church services; 9-11:30 pm. Founded May, 1923. Central.

WCBE

New Orleans, La. 227.1m-1320kc. 5 watts. Uhalt Brothers Radio Co. Announcer, Joe Uhalt. Slogan, "Second Port U. S. A." Daily ex Sun, 11:30-12:30 pm. Daily, 7:30-8:30 pm, dance. Sun, 12:30-3 pm, dinner concert; 9, dance music. Central.

WCBM

Baltimore, Md. 384.4m-780kc. 100 watts. Hotel Chateau. Announcer, Harry J. Dobe. Mon, Wed, Sat, 10-12 mid. Sun, 6 pm. Eastern. Founded March, 25, 1923.

WCBR

Providence, R. I. 201.2m-1490kc. 100 watts. Charles H. Messter. (Portable).

WCBS

Springfield, Ill. 209.7m-1430kc. 250 watts. Harold L. Dewing, Charles H. Messter. Slogan, "Home of Abraham Lincoln." Mon, 9-11 pm. Tues, Wed, Thurs, Fri, 8:30-10:30 pm. Sun, 10:45-12 n, 12:30-2 pm, 6-7, 7:30-8. Central.

WCCO

Minneapolis-St. Paul, Minn. 405.2m-740kc. 7500, 6 am-6 pm, 5000 watts. Washburn-Crosby Co. Announcer, Paul Johnson. Slogan, "Service to the Northwest." Daily ex Sun, 9:30 am, program for day; 9:35, news; 9:45, weather, markets; 10:30, markets; 11:30, markets; 1, weather, markets; 2, 3, markets; 5:45, livestock. Mon, 8, U. of Minn.; 9, program; 10, weather; 11, dance program; 11:45, organ. Tues, 8 pm, New York; 9:30, musicale; 10, weather. Wed, 6:45 pm; 8, WEAF; 8:30, program; 9, WEAF; 10, weather, grain; organ. Thurs, 6:15 pm, dinner concert; 7:15, talk; 8, WEAF; 8, weather, markets; 10:05, talk; 8, WEAF; 8, music; 9, WEAF; 9:30, music; 10, weather; 10:05, music. Sat, 6:15 pm, music; 7:45, talk; 9, music; 10, weather, dance program. Founded Oct. 1, 1924. Central.

WCDA

Brooklyn, N. Y. 211.1m-1420kc. 250 watts. Italian Educational Broadcasting Co.

WCFL

Chicago, Ill. 483.6m-620kc. 1500 watts. Chicago Federation of Labor. Announcer, Maurice Wetzel. Slogan, "The Voice of Labor." Daily ex Sun, 4-12 mid. Central.

WCGU

Coney Island, N. J. 218.8m-1370kc. 500 watts. Charles G. Unger. Daily ex Sun, 1 pm. Wed, Fri, 8 pm. Sun, 11 am. Eastern.

WCLO

Camp Lake, Wis. 227.1m-1320kc. 100 watts. C. E. Whitmore. Slogan, "The Playground of the Lake Region." Daily ex Tues, Thurs, 11:30 am, 2:30-5:30, 7-12 mid. Central.

WCLS

Joliet, Ill. 215.7m-1390kc. 150 watts. M. A. Felman Co. Slogan, "Will County's Largest Store." Tues, Wed, Thurs, Fri, Sat, 8-11 pm. Sun, 9:30-12 n, 10-11. Central.

WCMA

Culver, Ind. 258.5m-1160kc. 250 watts. Culver Military Academy. Announcer, C. F. McKinney. Daily ex Sun, 12 n, public service hour. Mon, 8-10:30 pm. Wed, 8-10:30 pm. Fri, 8-10:30 pm. Sun, 11-12:30 pm, chapel service. Founded 1925. Central.

WCOA

Pensacola, Fla. 249.9m-1200kc. 500 watts. Municipal Broadcasting Station. Announcer, John E. Franklin. Slogan, "Wonderful City of Advantages." Daily ex Sun, 10:30 am, 12:30 pm. Mon, Wed, Fri, 7 pm. Sun, 11 am, 12:30, 7:45 pm. Central.

WCOC

Columbus, Miss. 230.6m-1300kc. 250 watts. Crystal Oil Co. Announcer, Park Balch. Founded Feb. 26, 1927.

WCOT

Obeyville, R. I. 225.4m-1330kc. 50 watts. Jacob Conn.

WCRW

Chicago, Ill. 223.7m-1340kc. 500 watts. Clinton R. White. Announcers, C. R. White, Charles P. Hughes. Slogan, "For Your Entertainment." Daily ex Sun, 11:30-1 pm. Daily ex Mon, 6:30-7:30 pm, 9:30-10:30. Central.

WCSH

Portland, Me. 428.3m-700kc. 500 watts. Congress Square Hotel. Announcer, L. T. Pitman, H. C. Wing. Daily ex Sat, Sun, 9-10 am, housewives' hour; 12-1:30 pm, stocks, weather; 2-3, musicale; 7-8, stocks, sports. Mon, 11:45 am, Civitans' club; 9, WEAF. Tues, 8 pm, Strand theater; 9, WEAF. Wed, 8:30, WEAF; Thurs, 6:30 pm, WEAF. Fri, 7:30 pm, concert; 8, Treasure Hunters. Founded June, 1925. Eastern.

WCSSO

Springfield, Ohio. 256.3m-1170kc. 500 watts. Wittenberg College. Announcer, Lester Crowl. Fri, 8-9 pm. Central.

WCWK

Fort Wayne, Ind. 214.2m-1400kc. 250 watts. Chester W. Keen. Slogan, "The Home Sweet Home Station." Fri, 7-8 pm. Sat, 8-10 pm. Sun, 11-12 n, 5-5:30 pm, 5:30-6:30, 6:30-7:30 pm. Founded, 1924. Central.

WCWS

Danbury, Conn. 214.2m-1400kc. 100 watts. Bridgeport Broadcasting Station. Founded Aug. 2, 1926.

WCX

Pontiac, Mich. 440.9m-680kc. 5000 watts. The Detroit Press. Announcer, C. D. Tomp. Club, "Red Apple Club." Daily ex Sun, 4 pm, music, 4:15, news, markets, weather; 5:45, Skeezix time. Eves' blue chain. Tues, 10-2 am, club. Eastern.

WDAD

Nashville, Tenn. 225.4m-1330kc. 1000 watts. Dad's Auto Accessories, Inc. Announcer, F. E. Exum. Slogan, "The Athens of the South." Mon, Wed, Sat, 11:45 am, 12:45, 3-4 pm, 9-10. Tues, Fri, 11:45 am, 12:45, 3-4 pm, 7-9 pm. Sun, 3-4:30 pm, 6:30. Central.

WDAE

Tampa, Fla. 267.7m-1120kc. 500 watts. Tampa Daily Times. Announcer, Bruce Lum. Daily ex Sun, 7-12 mid. Sun, 7:30-9:30 pm. Eastern.

WDAF

Kansas City, Mo. 370.2m-810kc. 1000 watts. Kansas City Star. Announcer, H. Dean Fitzer. Club, "Nighthawks." Daily ex Sun, 8:30 am, 9:30, 10:30, 11:30, 12:15 pm, grain quotations. Daily ex Sun, 8 am, Bible lesson; 12-1 pm, around the town; 3-4, matinee; 6-7, school of the air; 7-10, musicale; 11:45-1, Nighthawk frolic. Sun, 3 pm, 4, 5, 6, base ball. Sun, 4-6 pm, band concert. Founded June, 5, 1922. Central.

WDAG

Amarillo, Tex. 263m-1140kc. 250 watts. J. Lawrence Martin. Daily ex Sun, Fri, 12:45-1:45 pm. weather, markets, farm; 9-10:30 pm, music. Fri, 8-9 pm. Sun, 9:45-10:45 am, 7:30-9:30 pm. Central.

WDAH

El Paso, Tex. 234.2m-1280kc. 100 watts. Trinity Methodist church. Announcer, Louis Gemoets. Wed, 7:30-10 pm. Sun, 9:30-12 n, 7:30-9 pm. Founded Spring 1924. Mountain.

WDAY

Fargo, N. D. 361.2m-830kc. 250 watts. Radio Equipment Corporation. Announcer, Kenneth M. Hance. Slogan, "The Biggest Little City in the World." Daily ex Sun, 7-9 am, news, 9, markets; 10, weather, news; 10:15, chapel service; 11, markets; 12, music; 1, 3-4, 5, musicale; 5:15, 5:45, news; 6, entertainment; 7:30-8:15, Sun, 10:30 am, service; 1 pm, 2, 4-6. Central. Founded May, 1922.

WDBJ

Roanoke, Va. 230.6m-1300kc. 250 watts. Richardson Wayland Elec. Corp. Announcer, J. W. Johnson. Slogan, "Roanoke Down in Old Virginia." Daily ex Sun, 12-1 pm, music; 5:30-6:45, music, news, weather. Mon, 8-9 pm. Wed, Sat, 9 pm, concert. Sun, 7:45 pm, church. Eastern.

WDBO

Orlando, Fla. 288.3m-1040kc. 1000 watts 6 am-6 pm, 500 watts. Orlando Broadcasting Co. Announcer, Harold Dant. Slogan, "The Voice of Central Florida." Daily ex Sun, 7:39-10:30 pm. Sun, 10:45 am, 4 pm, 7:30. Founded 1921. Eastern.

WDEL

Wilmington, Del. 265.3m-1130kc. 100 watts. Wilmington Elec. Spec. Co. Announcer, Harvey Smith. Slogan, "The First Broadcasting Station of the First City of the First State." Tues, Thurs, Sat, 8-9 pm. Sun, 10-12 mid. Eastern.

WDGY

Minneapolis, Minn. 260.7m-1150kc. 500 watts. Dr. George Young. Mon, Wed, 7-8 pm, 10-12. Tues, 7-12 mid. Thurs, 7-10 pm. Fri, 7-8 pm, 10-12. Sat, 7-8 pm. Sun, 2-6 pm. Central. Founded 1923.

WDOD

Chattanooga, Tenn. 245.8m-1220kc. 500 watts. Chattanooga Radio Co., Inc. Announcer, Frank S. Lane. Daily ex Sun, 12-1:15 pm. Mon, 7-11 pm. Tues, Wed, Fri, 7-10 pm. Sat, 9-10 pm. Sun, 11-12:10 pm, 1-2, 7:30-9. Founded 1925. Central.

WDRG

New Haven, Conn. 282.3m-1060kc. 500 watts. Doolittle Radio Corp. Announcer, F. M. Doolittle. Daily ex Sat, Sun, 11-12 mid, 6:45-10 pm. Sun, 11-12:30 pm. Eastern.

WDWF

WLSI

Cranston, R. I. 374.8m-800kc. 500 watts. Dutee W. W. S. Slogan, "Quality First." Eastern.

WDWM

Asbury Park, N. J. 361.2m-820kc. 500 watts. Radio Industries Broadcast Co. Announcer, Franklin D. Scott. Daily, 2-12 mid. Eastern. Founded July 1, 1927.

WDZ

Tuscola, Ill. 277.6m-1080kc. 100 watts. James L. Bush. Announcer, G. R. Muir. Daily ex Sun, 9 am, 9:30, 10, 10:30, 11, 11:30, 12 n, 12:30, 1, 1:15, 1:30, 2:45, grain, markets, livestock, markets. Central.

WEAF

New York, N. Y. 491.5m-610kc. 5000 watts. National Broadcasting Co., Inc. Slogan, "The Voice to the Millions." Daily ex Sun, 6:45-8 am, 8-8:45, 11-1:15 pm, 4-12 midnight. Sun, 2-10:30 pm. Eastern.

WEAM

North Plainfield, N. J. 239.9m-1250kc. 250 watts. Borough of North Plainfield. Announcer, H. W. Blackford. Slogan, "America's Pioneer Municipal Broadcasting Station." Fri, 8-12 pm, concert, talks. Sun, 11-12 noon. Eastern.

WEAN

Providence, R. I. 319m-940kc. 500 watts. The Shepard Stores. Announcer, Chester H. Miller. Slogan, "We Entertain a Nation." Daily ex Sun, 12-1 pm, 4-5, music, reports, weather, concert; 6:30-10:30. Sun, 10:45-11:30 am, 7:30-8:45 pm, church service. Eastern.

WEAO

Columbus, Ohio. 282.8-1060kc. 750 watts. Ohio State University. Announcer, Robert Coleman. Slogan, "Where Education Advances Ohio." Daily ex Sun, 9:45 am, 11, 12:30 pm, 4, Tues, 7 pm. Wed, 7-8:30 pm; Thurs, 7-10:30 pm. Eastern.

WEAR

Cleveland, Ohio. 399.8m-750kc. 1000 watts. Willard Storage Battery Co. Daily ex Sun, 11:30 am, markets, time, weather. Daily ex Sun, Sat, 3:30 pm, markets, weather. Eastern.

WEBC

Superior, Wis. Duluth, Minn. 241.8m-1240kc. 250 watts. Head-of-the-Lakes Radio Station. Daily ex Sun, 1:15 pm, 5, markets; 6, orchestra. Mon, 8 pm, music. Wed, 8:30 pm. Fri, 9 pm. Sun, 10:40 am, services. Central.

WEBE

Cambridge, Ohio. 247.8m-1210kc. 10 watts. Roy W. Waller. Fri, 7:45-9:15 pm. Sun, 7:30-8:30 pm. Eastern.

WEBH

Chicago, Ill. 365.6m-820kc. 2000 watts. Edgewater Beach Hotel-Herald-Examiner. Announcer, Robert Boniel. Slogan, "The Voice of the Great Lakes." Daily ex Sun, 3-4 pm, music; 5:5-4:5, children's club. Daily ex Sun, Mon, 7-8 pm, dinner concert. Tues, 9-11 pm, uptown theater. Wed, 9-11 pm, musicale; 12-1 pm, revue. Thurs, 9-11 pm, musicale. Fri, 9-11 pm, Sat, 10-12 mid. Sun, 6 pm, organ; 7-9, orchestra. Central.

WEBJ

New York, N. Y. 256.3m-1170kc. 500 watts. Third Avenue Railway Co. Announcer, H. A. Bruno. Slogan, "The Red Trolley Station." Tues, Fri, 7-9 pm. Wed, 8-10 pm. Eastern.

WEBQ

Harrisburg, Ill. 223.7m-1340kc. 15 watts. Tate Radio Co. Announcer, Dr. H. J. Raley. Slogan, "The Voice from Egypt." Daily ex Sun, 7:15-7:45 pm. Mon, Thurs, 8-10 pm. Sun, 11-12 n, 2-4 pm, 7-8. Central. Founded Sept. 1, 1923.

WEBR

Buffalo, N. Y. 241.8m-1240kc. 200 watts. H. H. Howell. Announcer, Glenn Pickett. Slogan, "We Extend Buffalo's Regards." Daily ex Sun, 7:45-8:30 pm. Mon, Wed, Fri, 8:30-11:30 pm. Sat, 9-11 pm. Sun, 12 n, concert; 8-9 pm, church; 10:15-12 mid, organ. Eastern.

WEBW

Beloit, Wis. 258.5m-1160kc. 500 watts. Beloit College. Announcer, Arthur Weimer. Sun, 4:30 pm. Central.

WEDC

Chicago, Ill. 241.8m-1240kc. 500 watts. Emil Dene-mark, Broad. Station. Slogan, "It Won't Be Long Now." Daily, 6-7:30, 9:30-11:30. Daily ex Sun, 6:30-7:30 pm, Jewish hour. Fri, 6:30-7:30 pm, Bohemian hour. Central.

WEEI

Boston, Mass. 447.5m-670kc. 500 watts. Edison Elec. Illuminating Co. Announcer, Arthur F. Edes. Slogan, "The Friendly Voice." Daily ex Sun, 6:45 am, exercises; 7:45, Roaring Lyons. Mon, 4 pm, 5:30, 6:30-10:30, 10:30. Tues, 3 pm, 4, 6:30-10, 10. Wed, 4 pm, 6:30-10, 10. Thurs, 4 pm, 6:30-10, 10. Fri, 4 pm, 6:30-10, 10. Sun, 10:05 am, 7, news; 7:20, 9:20. Eastern. Founded Sept. 29, 1924.

WEHS

Evanston, Ill. 215.7m-1390kc. 100 watts. Victor C. Carlson. Daily ex Sun, Mon, 6:15-9 pm. Wed, Fri, Sat, 10-12 mid. Thurs, 11-12 mid. Sun, 6:30-9 pm. Central.

WEMC

Berrien Springs, Mich. 483m-620kc. 1000 watts. Emanuel Missionary College. Announcer, Paul N. Pearce. Slogan, "The Radio Lighthouse." Daily ex Sat, Sun, 7:30-9 am. Mon, 7-12 mid. Tues, Thurs, 3-4 pm. Sun, 9-10 am, 11-12. Central. Founded April 1, 1923.

WENR

Chicago, Ill. 288.3m-1040kc. 500 watts. Great Lakes Radio Broadcasting Co. Daily ex Sun, Mon, 11 am, Mrs. Peterson. 12-1 pm, concert; 2-5, popular request; 6-7, dinner concert; 8-9:30, classical; 9:30-12 mid. Mon, 12-1 pm, 2-5, 6-7. Sun, 2-4 pm, 6-7, 9:30-11. Founded Sept. 29, 1925. Central.

WEPS

Gloucester, Mass. 296.9m-1010kc. 100 watts. Matheson Radio Co., Inc.

WEVD

Woodhaven, N. Y. 245.8m-1220kc. 500 watts. Debs Memorial Radio Fund.

WEW

St. Louis, Mo. 352

WGST
Atlanta, Ga. 270.1m-1110kc. 500 watts. Georgia School of Technology. Announcer, Walter W. Merkle. Slogan, "The Southern Technical School with a National Reputation." Founded Jan., 1924.

WGWB
Milwaukee, Wis. 218.8m-1370kc. 500 watts. Radio-cast Corp. of Wisconsin. Announcer, John Sullivan. Slogan, "Make Milwaukee Mightier." Daily ex Sun, Sat, 10:30-12:30 pm. Mon, 8-10:30 pm. Wed, 8-9 pm. Fri, 9-10:30 pm. Sun, 10-11 am. 6-7 pm. Central.

WGY
Schenectady, N. Y. 379.5m-790kc. 50,000 watts. General Electric Company. Announcer, Kohn Hager. Slogan, "Good Evening to You All." Daily ex Sun, 5:45-7 am, exercises; 7:30, talk; 11:55 am, time; 12:01, weather; 12:02, produce; 12:06, weather; 1 pm, music; 1:30, orchestra; 5, stocks; 5:25, baseball; 5:30, orchestra; 6:25, baseball. Tues, 6:30-10:30 pm. Wed, 5:30-10 pm. Thurs, 5:30-10:30 pm. Fri, 5:30-10:30 pm. Sat, 6:30-11 pm. Sun, 10 am, 1-2 pm, 6:20. WEAF, 8:15, time; 8:15 WEAF, 8:45, WEAF. Tues, Thurs, Sat, 2XAF, 32.77m. Mon, Wed, Fri, Sun, 2XAD, 22.02m. Eastern. Founded, 1922.

WHA
Madison Wis. 319m-940kc. 750 watts. Univ. of Wis. Mon, 7:30-10 pm. Wed, Fri, 8-9 pm. Central.

WHAD
Milwaukee, Wis. 270.1m-1110kc. 500 watts. Marquette University.

WHAM
Rochester, N. Y. 277.6m-1080kc. 5000 watts. Univ. of Rochester. Stromberg-Carlson Tel. Mfg. Co. Announcer, E. P. Chappell. Daily ex Sun, 6:30-11 pm. Tues, 2:30-4 pm. Sun, 10:30-12 n. 3:30-5, 6:30-11. Eastern.

WHAP
New York, N. Y. 236.1m-1270kc. 1000 watts. Defenders of Truth Society, Inc. Mon, Thurs, 6-9 pm. Wed, 9-11:30 pm. Sat, 7-11:30 pm. Sun, 7:30-9:30 pm. Eastern. Founded May, 1925.

WHAR
Atlantic City, N. J. 272.6m-1100kc. 1000 watts. Seaside Hotel. Announcer, E. Dennison. Pioneer Broadcasting Station of Atlantic City. Daily ex Sun, Wed, 2:15-3:15 pm, 7:45-9, Sun, 10:45 am, 2:15-3:10 pm, 7:30-9. Founded, 1922. Eastern.

WHAS
Louisville, Ky. 461.3m-650kc. 500 watts. Courier-Journal and Louisville Times Co. Announcer, D. H. Ives. Daily ex Sun, 2:15 pm, 3:30-5, 7-9. Sun, 3 am, service; 2-3, 4:30-5:30. WEAF. Founded July, 1922. Central.

WHAZ
Troy, N. Y. 379.5m-790kc. 500 watts. Rensselaer Polytechnic Inst. Announcer, Rutherford Hayner. Slogan, "Transcontinental and International Broadcasting Station Located at the Oldest College of Science and Engineering in America." Club, R. P. I. students. Mon, 8-12 midnight, concert, educational talks, orchestra, features. Founded June 22. Eastern.

WHB
Kansas City, Mo. 336.9m-890kc. 500 watts. Sweeney Auto & Electrical School. Announcer, John T. Schilling. Slogan, "Heart of America." Daily ex Sun, 8:25 am, 9:25, 10:25, 10:30, 11:20, 11:30, 11:56, 12 n. market reports; 2-3, ladies' hour. Daily ex Sun, Sat, 12:15 pm, 12:30, 1:25, 1:40, stocks. Daily, 7-8 pm. Mon, 8-9 pm. Tues, Thurs, 8-10 pm. Sat, 12:05 pm, 12:30, 1:25, markets. 8-10 pm. Sun, 9:45-10:45 am, service; 7-7:45; 11:15-11 am, organ. Central. Founded April, 1922.

WHBA
Oil City, Pa. 260.7m-1150kc. 10 watts. Shaffer Music House. Tues, 9-10 pm. Eastern. Founded Nov., 1924.

WHBC
Canton, Ohio. 236.1m-1270kc. 10 watts. Rev. E. P. Graham. Slogan, "Ignorance Is Our Greatest Foe." Mon, 8-8:30 pm. Central.

WHBF
Rock Island, Ill. 222.1m-1350kc. 100 watts. Beardsley Specialty company. Announcer, C. L. Beardsley. Slogan, "Where Historic Blackhawk Fought." Mon, Wed, 9-11 pm, Sat, 2-4 pm. 7-9. Central.

WHBL
Chicago, Ill. 204m-1470kc. 100 watts. C. L. Carroll. (Portable.) Founded, 1925.

WHBM
Chicago, Ill. 201.2m-1490kc. 100 watts. C. L. Carroll. (Portable.)

WHBN
Gainesville, Fla. 296.9m-1010kc. 5000 watts. U. of Florida.

WHBP
Johnstown, Pa. 228.9m-1310kc. 250-500 watts. Johnstown Automobile Announcer, J. C. Tully. Slogan, "The Voice of the Friendly City." Daily ex Sun, 1:15 pm. Mon, 11 pm. Thurs, 10 pm. Sat, 10 pm. Eastern.

WHBQ
Memphis, Tenn. 232.4m-1290kc. 100 watts. Broadcasting Station WHBQ, Inc. Announcer, Thomas Thompson. Daily ex Sun, 7-8 pm. Sun, 10:45 am. Central. Founded March, 1925.

WHBU
Anderson, Ind. 220.4m-1360kc. 15 watts. Citizen's Bank.

WHBW
Philadelphia, Pa. 220.4m-1360kc. 100 watts. D. R. Kleuzie. Mon, Wed, Sat, Sun, evenings.

WHBY
West De Pere, Wis. 249.9m-1200kc. 50 watts. St. Norbert's College. Green Bay-De Pere Broadcasting Station. Daily, 6 pm, weather, markets. Wed, Fri, Sat, Sun, 5-6 pm. Mon, Fri, 8-10 pm. Central. Founded Jan., 1925.

WHDI
Minneapolis, Minn. 245.8m-1220kc. 500 watts. Wm. Hood Dunwoody Industrial Institute. Announcer, M. R. Bass. Slogan, "Northwest Leading Trade School." Mon, 8-9 pm. Wed, 8:30 pm. Fri, 9-10 pm. Daily ex Sun, 6:57-9:30 am, time. Central. Founded May 22, 1922.

WHEC
Rochester, N. Y. 277.6m-1180kc. 500 watts. Eflexion Electric Company, Inc. Announcer, Milton Hall. Slogan, "The City of Varied Industries." Announcer, Edward H. Troan. Daily ex Sun, 12-3 pm, 6-10. Sun, 10:30-12 n, 7:30-10 pm. Eastern.

WHFC
Chicago, Ill. 215.7m-1390kc. 200 watts. Woodson & Wilson, Inc. Daily ex Mon, 8-12 mid. Central daylight.

WHK
Cleveland, Ohio. 265.3m-1130kc. 1,000 watts. Radio Air Service Corp. Slogan, "Cleveland Pioneer Broadcasting Station. Daily, 12 n., 10-11 pm, music; 3:30, housekeepers' chat; 5, 5:15, 6, 8, 9, 10, 11-12. Sat, 12 n. 3:30 pm; 5, 5:15, 6, 8, 9, 9-12 mid. Sun, 10 am, 5 pm, 5:15, 6, 7:30, 8:15-9:30. Eastern.

WHN
New York, N. Y. 394.5m-760kc. 500 watts. Loew's State Broadcasting Station. Announcers, N. T. G., Edward B. Husing. Slogan, "The Voice of the Great White Way." Daily ex Sun, 12:30-1 pm, 2:15-3:15, 3:45-5:30, 6:30-12 mid. Sun, 12:30-6 pm; 9:30-12. Eastern. Founded March, 1922.

WHO
Des Moines, Ia. 535.4m-560kc. 5000 watts. Bankers Life Co. Announcer, N. Dean Cole. Daily ex Sun, 9:45 am, 12 n, 2, 2:15 pm, markets, weather. Tues, Thurs, Fri, 6:30-10 pm. Mon, 6:30-12 mid. Wed, 6:30-11 pm. Sun, 11 am. 4-9 pm. Central. Founded 1924.

WHPP
New York, N. Y. 206.8m-1450kc. 10 watts. WHPP, Inc.

WHT
Deerfield, Ill. 416.4m-720kc. 5000 watts. Wrigley Bldg. Announcer, Patrick Henry Barnes. Slogan, "Write Home Tonight." Daily ex Mon, 10-2:30 pm, 7-10. Tues, Thurs, 11-1 am. Central. Founded April 25, 1925.

WIAD
Philadelphia, Pa. 288.3m-1040kc. 100 watts. Howard R. Miller. Slogan, "The Voice from the Birthplace of Liberty." Tues, Thurs, Fri, 6-12 mid. Eastern. Founded June, 1922.

WIAS
Ottumwa, Ia. 475.9m-630kc. 100 watts. Polling Elec. Co. Announcer, Frank B. Ori. Slogan, "Burlington on the Mississippi." Wed, 8 pm. Mon, Fri, 8 pm. Sat, 10:30 pm. Sun, 10:30 am. Central.

WIBA
Madison, Wis. 239.9m-1250kc. 100 watts. The Capital Time Strand theater. Announcer, Kenneth F. Schmitt. Slogan, "Four Lakes City." Mon, 7-11 pm. Wed, 8-10 pm. Fri, 6:15-7 pm. Sat, 7-8 pm. Sun, 12-1 pm. Central. Founded June, 1924.

WIBG
Elkins Park, Pa. 440.9m-680kc. 50 watts. St. Paul's Protestant Episcopal church. Announcer, David P. Guilette. Sun, 11 am, 3:45 pm. Eastern.

WIBI
Port Washington, N. Y. 267.7m-1120kc. 100 watts. Frederick B. Zittel, Jr.

WIBJ
Chicago, Ill. 201.2m-1490kc. 100 watts. C. L. Carroll. (Portable.)

WIBM
Chicago, Ill. 201.2m-1490kc. 100 watts. C. L. Carroll. (Portable.)

WIBO
Chicago, Ill. 416.4m-720kc. 5000 watts. Nelson Brothers Bond and Mfg. Co. Announcer, Walter Preston. Daily ex Sun, 2:30-7 pm. Tues, Thurs, 10-11 pm. Wed, Fri, Sat, Sun, 10-11 am. Sun, 8:45-10 am. Central. Founded May 20, 1925.

WIBR
Steubenville, Ohio. 249.9m-1200kc. 50 watts. Thurman A. Owings. Announcer, Robert Merryman. Slogan, "Where Investments Bring Results." Daily ex Sun, 6:30-7:30 pm. Wed, 11:15-12:45 am. Mon, Fri, 8:30-10 pm. Sun, 4-5 pm. Founded Jan., 1925. Eastern.

WIBS
Elizabeth, N. J. 204m-1470kc. 150 watts. New Jersey National Guard.

WIBU
Poyntette, Wis. 217.3m-1380kc. 20 watts. The Electric Farm. Wisconsin State Journal. Mon, 9 pm. Sun, 2 pm, 4. Central. Founded July 10, 1925.

WIBW
Chicago, Ill. 204m-1470kc. 100 watts. C. L. Carroll. (Portable.) Chicago. Founded 1926.

WIBX
Utica, N. Y. 238m-1260kc. 150 watts. Hotel Utica. Announcer, J. B. Hyland. Mon, Tues, Thurs, Fri, Sat, Sun, services. Founded June, 1924.

WIBZ
Montgomery, Ala. 230.6m-1300kc. 15 watts. A. D. Trum.

WICC
Sport Hill, Conn. 214.2m-1400kc. 500 watts. The Bridgeport Broadcasting Station. Announcer, Charles W. Selen. Slogan, "The Industrial Capitol of Connecticut." Mon, Tues, Thurs, Fri, 8-10 pm. Sun, 9:50 am. Eastern. Founded Aug. 2, 1926.

WIL
St. Louis, Mo. 258.5m-1160kc. 250 watts. Benson Broadcasting Co. Announcer, Billy Knight. Daily and Sun, 9:30-11:30 am, 2:45-5 pm. Daily ex Thurs, 8-11 pm. Central. Founded Sept., 1922.

WIOD
Miami Beach, Fla. 247.8m-1210kc. 1000 watts. Carl G. Fisher. Announcer, Jesse H. Jay. Slogan, "Wonderful Isle of Dreams."

WIP
Philadelphia, Pa. 508.2m-590kc. 500 watts. Gimbel Bros. Announcer, E. A. Davies. Slogan, "Watch Its Progress." Daily ex Sun, 12 pm, 8-10, 6-7:30. Tues, Thurs, Sat, 10-10:30 am. Tues, Thurs, Sat, 8-12 mid. Sun, 10:45-12 n, 9-12 mid, alternate Sundays; 7:15-12 mid. Eastern.

WJAD
Waco, Texas. 447.5m-670kc. 500 watts. Hotel Raleigh. Mon, Tues, Thurs, 6:30-7:30 pm. Mon, Tues, Thurs, Fri, 8:30-10 pm. 1st and 3rd Wed, 8:30-9:30 pm. Central.

WJAG
Norfolk, Nebr. 285.5m-1050kc. 250-500 watts. Norfolk Daily News. Announcer, Karl Stefan. Slogan, "The World's Greatest Country Daily, and Home of Printer's Devil." Daily ex Sun, 12:15 pm; Wed, Sat, 6:30-7:30 pm, orchestra. Sun, 3 pm. Central.

WJAK
Kokomo, Ind. 234.2m-1280kc. 50 watts. Kokomo Tribune. Daily ex Sun, 11:45 am, chapel. Mon, 7:30 pm, music. Tues, Wed, Thurs, 6 pm, concert. Founded Sept., 1921. Central.

WJAM
Cedar Rapids, Iowa. 352.7m-850kc. 250 watts. D. M. Perham. Daily ex Sun, 8:30-9:15 am, 12:40-1:15 pm. Mon, Wed, Fri, 7-9 pm. Tues, Thurs, 9-11 pm. Central. Founded July 29, 1922.

WJAR
Providence, R. I. 483.6m-620kc. 500 watts. The Outlet Co. Announcer, J. A. Reilly. Slogan, "The Southern Gateway of New England." Daily ex Sun, 1:05-2 pm, weather, reports, music. Mon, Wed, Fri, 10 am, household hints. Mon, 8-11 pm. Tues, 8-10 pm. Wed, 7:30-11 pm. Thurs, 8-11 pm. Fri, 8-10:30 pm. Sat, 8-9 pm. Sun, 7:20-10:15 pm. Eastern.

WJAS
Pittsburgh, Pa. 270.1m-1110kc. 500 watts. Pittsburgh Radio Supply House. Pickering's Studio. Announcer, Tom Morris. Slogan, "World's Jolliest Aerial Station." Daily ex Sun, 12 n, 12:45, 7:30, 8, 8:15, 9:30, 10:30. Sun, 11-2 pm, 3-5, 9-11. Eastern.

WJAX
Jacksonville, Fla. 336.9m-890kc. 1000 watts. City of Jacksonville. Daily ex Sun, 11:55-12:05 pm. Daily ex Sun, Thurs, 7:30-11 pm. Sun, 11 am, 6:30-7:30 pm, 8-9. Eastern. Founded Nov. 26, 1925.

WJAY
Cleveland, Ohio. 227.1m-1320kc. 500 watts. Cleveland Radio Broadcasting Corp. Announcer, Johnny Mack. Slogan, "On the Hollenden." Daily ex Sun, 12 am, 12 organ; 1, 6-12 mid. Sun, 10:30 am, services; 6:30 pm, 7, 11 pm, 11, time. Central.

WJAZ
Mt. Prospect, Ill. 263m-1140kc. 5000 watts. Zenith Radio Corp. Announcer, George G. Smith. Daily ex Sun, Mon, Thurs, 7-8 pm, 9-11. Thurs, 9-12 mid. Sun, 7-9 pm. Founded 1922. Central.

WJBA
Joliet, Ill. 322.4m-930kc. 50 watts. D. H. Lentz, Jr. Tues, Thurs, Fri, Sat, 7-12 mid. Central.

WJBB
Tampa, Fla. 344.6m-870kc. 250 watts. Financial Journal.

WJBC
La Salle, Ill. 227.1m-1320kc. 100 watts. Hummer Furniture Co. Announcer, LeRoy Stremlau. Slogan, "Better Home Station." Daily ex Sun, 12:30-1:30 pm. Mon, 8-10 pm. Sat, 4-5 pm. Sun, 10-11:30 am, 3:30-4:45 pm, 7:30-9:30 pm. Founded May 4, 1925. Central.

WJBI
Red Bank, N. J. 263m-1140kc. 150 watts. Robert S. Johnson.

WJBK
Ypsilanti, Mich. 220.4m-1360kc. 15 watts. Ernest Goodwin. Announcer, H. T. Augustus. Mon, 9-11 pm. Thurs, 10-12 mid. Sat, 11-12 mid. Eastern.

WJBL
Decatur, Ill. 212.6m-1410kc. 250 watts. William Gushard Dry Goods Co. Announcer, W. H. Wiley. Mon, 9-10:30 pm. Wed, 9-11 pm. Sat, 9-11:30 pm. Sun, 10:45-12:15 pm. Central. Founded Sept. 24, 1925.

WJBO
New Orleans, La. 263m-1140kc. 100 watts. Valdemar Jensen. Founded 1922.

WJBR
Omro, Wis. 227.1m-1320kc. 100 watts. Gensch and Stearns. Announcer, C. W. Stearns. Slogan, "The Center of the State of Lakes." Mon, Thurs, 8-10:30 pm. Sun, 2:20-4 pm, 8-10:30. Central. Founded Feb. 10, 1926.

WJBT
Chicago, Ill. 389.4m-770kc. 500 watts. John S. Boyd. Announcer, Floyd Taleh. Daily ex Sun, 10:30-11:15 am; 5-7 pm. Daily ex Sun, Mon, 11-12 mid. Sun, 6-6:30 pm, 11-12. Central.

WJBU
Lewisburg, Pa. 214.2m-1400kc. 100 watts. Bucknell university. Announcer, Geo. A. Irland. Slogan, "In the Heart of the Keystone State." Thurs, 8 pm. Eastern.

WJBW
New Orleans, La. 238m-1260kc. 30 watts. C. Carlson, Jr. Tues, Fri, 7-8 pm. Sun, 9-10 pm. Central.

WJBY
Gadsden, Ala. 234.2m-1280kc. 50 watts. Electric Construction Co. Mon, Wed, Fri, 8-9 p.m. Central. Founded Aug. 11, 1926.

WJBZ
Chicago Heights, Ill. 208.2m-1440kc. 100 watts. Roland G. Palmer. Anthony Coppote. Mon, Wed, Fri, 7-12 mid. Central.

WJJD
Mooseheart, Ill. 365.6m-820kc. 1000 watts. Loyal Order of Moose station, Palmer House. Herald Examiner. Announcer, Gene Rouse. Slogan, "The Call of the Moose." Daily ex Sun, 10 am, news; 10:30, organ; 11-12 n., Prudence Penny; 12, music; 4 pm, piano reveries; 4:45, Palmer house soloists; 5:45, music; 6, symphony; 6:15, talk. Daily ex Sun, Mon, 8 pm. Tues, Fri, 11-1 am. Wed, Thurs, 11-12 mid. Sat, 9-10 pm, 12-2 am. Sun, 7:30-10:30 am, services; 1:30-2 pm, funnies; 2-4, Bible classes; 9, studio program; 10, news. Central.

WJKS
Gary, Ind. 232.4m-1290kc. 500 watts. Johnson Kennedy Radio Corp.

WJPW
Ashtabula, Ohio. 208.2m-1440kc. 30 watts. J. P. Wilson. Mon, Wed, Fri, 7:45 pm, 8:30-11. Sun, 10:30-12 n, 7:30-8:30. Central.

WJR
Pontiac, Mich. 440.9m-680kc. 5000 watts. 8x A O, 32 m. The Richards-Oakland Co. Slogan, "Where Joy Reigns." Announcers, Leo Fitzpatrick, John F. Patt. Daily ex Sun, 12:45-2 pm, 6-12 mid. Mon, Wed, Fri, 10 am, Sun, 10 am, service; 2, service; 3:30, symphony; 6-10:30 pm. Eastern. Founded August, 1925.

WJZ
Bound Brook, N. J. 454.3m-660kc. 30,000 watts. R. C. A. Managed by National Broadcasting Co. Announcers, Milton J. Cross, Marley Sherris, Norman Sweetser, Curt Peterson. Daily 1-2:40 pm, 4:10, 6, 6:50-11:30 pm. Sun, 9-10 am; 1-3 pm, 5:30-6:50, 7-10:30. Founded 1921. Eastern.

WKAQ
San Juan, Porto Rico. 340.7m-880kc. 500 watts. Radio Corporation of Porto Rico. Announcer, Joaquin Agusti. Slogan, "The Island of Enchantment. Where the World's Best Coffee Grows." Wed, 8-10 pm. Intercolonial.

WKAR
East Lansing, Mich. 285.5m-1050kc. 500-1000 watts. Michigan State College. Announcer, Keith Himebaugh. Daily ex Sun, 12-12:30 pm, weather, markets, agricultural topics. Eastern.

WKAV
Laconia, N. H. 223.7m-1340kc. 50 watts. Laconia Radio club. Fri, 7:30 pm. Sun, 10:45 am; 6:30-8:15. Eastern. Founded Oct. 1, 1922.

WKBB
Joliet, Ill. 215.7m-1390kc. 150 watts. Sanders Brothers. Mon, 7-9 pm. Tues, Thurs, 8-12 mid. Sun, 3-5 pm. Central.

WKBC
Birmingham, Ala. 218.8m-1370kc. 10 watts. H. L. Ansley.

WKBE
Webster, Mass. 228.9m-1310kc. 100 watts. K. & R. Electric Co. Thurs, Sat, 8-10:30 pm. Eastern daylight. Founded Feb. 27, 1925.

WKBF
Indianapolis, Ind. 275.1m-1090kc. 250 watts. Noble B. Watson. Daily ex Sun, 10 am, 10:30, 10:40, 5 pm, 7, 7:10. Daily ex Sun, Mon, Sat, 12 n. Mon, 7:30 pm, 8:30, 9. Tues, 8:30-10:30 pm. Thurs, 7:30-10 pm. Fri, 7:30, 8-9:30 pm. Sun, 2:30 pm, 3:30. Founded Oct., 1925. Central.

WKBG
Chicago, Ill. 201.2m-1490kc. 100 watts. C. L. Carroll. (Portable.)

WKBH
LaCrosse, Wis. 220.4m-1360kc. 500 watts. Callaway Music Co. Daily ex Sun, 10-11 am, 12 n. Mon, 8:30 pm. Wed, 9 pm. Sat, 10 pm. Sun, 10:30 am. Central. Founded 1924.

WKBI
Chicago, Ill. 322.4m-930kc. 50 watts. Fred L. Schoenwolf. Fri, Sat, Sun, 10-12 mid. Central.

WKBL
Monroe, Mich. 205.4m-1460kc. 15 watts. Monroa Radio Mfg. Co.

WKBN
Youngstown, Ohio. 214.2m-1400kc. 50 watts. Radio Electric Service Co. Daily ex Sun, 7:30 am, exercises. Tues, 5:45 pm. Thurs, 6 pm. Eastern.

WKBO
Jersey City, N. Y. 218.8m-1370kc. 500 watts. Canith Corp. Daily ex Sun, 12-1 pm. Mon, 6-9 pm. Tues, 5-8 pm. Wed, 1-2 pm. Thurs, 6-8 pm. Fri, 9-12 mid. Sat, 1-3 pm. Eastern.

WKBP
Battle Creek, Mich. 212.6m-1410kc. 50 watts. Battle Creek Enquirer and News.

WKBQ
New York, N. Y. 218.8m-1370kc. 500 watts. Starlight Amusement Park, Inc.

WKBS
Galesburg, Ill. 217.3m-1380kc. 100 watts. Permil N. Nelson. Announcer, Paul W. Palquist. Mon, Wed, Fri, 10-11 am, 12:30-1 pm, 2:30-3:30, 7-11. Tues, Thurs, 10-11 am, 12:30-1 pm, 2:30-3:30, 7-9, 10-11. Sat, 7-9 pm, 10-11. Sun, 1:30-3 pm. Central.

WKBT
New Orleans, La. 252m-1190kc. 50 watts. First Baptist church. Announcer, W. H. Green. Slogan, "The Gospel Wave." Sun, 11 am, 7:45 pm, service. Central.

WKBV
Brookville, Ind. 217.3m-1380kc. 100 watts. Knox Battery & Electric Co. Fri, 7-9 pm. Sun, 7-9 pm. Central.

WKBW
Buffalo, N. Y. 217.3m-1380kc. 500 watts. Churchill Evangelistic Assn., Inc. Daily ex Sun, 6:30 pm. Sun, 8:30 am, 2 pm, 6-8:15, 9:15-11. Eastern.

WKBZ
Ludington, Mich. 199.9m-1500kc. 15 watts. Karl L. Ashbacher. Mon, 8-10 pm. Sun, 10:30-12 n. 7-8:30 pm. Central.

WKDR
Kenosha, Wis. 322.4m-930kc. 15 watts. Edward A. Dato.

WKEN
Kenmore, N. Y. 204m-1470kc. 250 watts. WKEN Inc. Daily ex Sun, 6 pm. Mon, 8-10 pm. Tues, 7:45-10 pm. Thurs, 8-11 pm. Sun, 11 am, 7:30. Eastern. Founded Fall, 1925.

WKJC
Lancaster, Pa. 252m-1190kc. 50 watts. Kirk Johnson & Co.

WKRC
Cincinnati, Ohio. 333.1m-900kc. 500 watts. Koder Radio Corp. Mon, Wed, 6-8 pm, 9-11, 12-2. Tues, 6-7 pm, 9-12 mid. Thurs, 8-10 pm. Fri, 9-11 pm. Sat, 6-7 pm, 9-12. Sun, 11-12 n; 3-5 pm, 7-8, 9-11, 11:30-1. Eastern.

WKY
Oklahoma City, Okla. 288.3m-1040kc. 150 watts. WKY Radiophone Co. Daily 10-11 am, 6-7:30 pm. Mon, Wed, Fri, 9-11 pm. Central.

WLAC
Nashville, Tenn. 225.4m-1330kc. 1000 watts. Life and Casualty. Mon, Wed, Sat, 7-9. Wed, 1:30-2 pm. Thurs, 6-7 pm. Tues, Thurs, 9-12 mid. Sun, 9-10 pm. Central. Opened Nov. 24, 1925.

WLAP
Louisville, Ky. 267.7m-1120kc. 100 Watts 6 am-6 pm. 30 watts. Virginia av. Baptist Church. Fri, 9:30-10 pm. Sun, 11 am, 8-9:15 pm. Central.

WLB
Minneapolis, Minn. 245.8m-1220kc. 500 watts. U. of Minnesota. Tues, 4-5 pm, Wed, 6:15-7 pm, Fri, 4-5 pm. Central.

WLBG
Muncie, Ind. 209.7m-1430kc. 50 watts. D. A. Burton. Wed, 8-12 mid. Thurs, 9-12 mid. Fri, 8-11 pm. Sat, 7-11 pm. Sun, 2-4 pm. Central.

WLBH
Farmingdale, N. Y. 232.4m-1290kc. 30 watts. Jos. J. Lombardi. Announcer, H. J. Martin. Mon, Wed, Fri, 7:30-11 pm. Eastern.

WLBK
Wenona, Ill. 238m-1260kc. 250 watts. Wenona Legion Broadcasters, Inc. Mon, 7-12 mid. Wed, Fri, 7-9 pm. Sun, 9 am. Central.

WLBL
Stevens Point, Wis. 319m-940kc. 1000 watts. Wisconsin Dept. of Markets. Slogan, "Wisconsin Land of Beautiful Lakes." Daily ex Sun, 8 am, 9, 10, 11, 12 n. weather, markets; 1 pm, news. Thurs, Sat, 8-10 pm. Central.

WLBW
Cambridge, Mass. 230.6m-1300kc. 50 watts. Brown-Ing Drake Corporation.

WLBX
Chicago, Ill. 204m-1470kc. 50 watts. William Evert Hiler. (Portable.)

WLBO
Galesburg, Ill. 217.3m-1370kc. 100 watts. Frederick A. Trebbe, Jr. Tues, Thurs, Sat, 9-10 pm. Central. Founded Jan. 16, 1927.

WLBO
Atwood, Ill. 202.6m-1480kc. 25 watts. E. Dale Trout.

WLBR
Belvidere, Ill. 322.4m-930kc. 15 watts. Alford Radio Co. Mon, 7:30-8:30 pm. Fri, 7:30-8:30 pm. Sat, 11-1 am. Sun, 11-12 mid. Central.

WLBT
Crown Point, Ind. 322.4m-930kc. 50 watts. Harold Wendell.

WLBV
Mansfield, Ohio. 206.8m-1450kc. 50 watts. Mansfield Broadcasting Association. Announcer, Ray Davis. Mon, 6-7 pm, 9-11 pm. Wed, 9-11 pm. Sat, 9:30-12 mid. Sun, 10:30-12 n. Central.

WLBW
Oil City, Pa. 293.9m-1020kc. 500 watts. Petroleum Telephone Co. Mon, 9:30-11 pm. Thurs, 10-11:30 pm. Sun, 3:30-5 pm. Eastern.

WLBX
Long Island, N. Y. 204m-1470kc. 250 watts. John N. Braby.

WLBZ
Iron Mountain, Mich. 209.7m-1430kc. 50 watts. Aimone Electric. Daily and Sun, 12-1 pm. Central.

WLBZ
Foxcroft, Me. 208.2m-1440kc. 250 watts. Thompson L. Guernsey.

WLCI
Ithaca, N. Y. 247.8m-1210kc. 50 watts. Lutheran Radio of Ithaca. Announcer, Robert F. Schuetz. Slogan, "The Church at the Gate of the Campus." Sun, 10:45 am, 7:45 pm. Eastern.

WLIB
Elgin, Ill. 305.9m-980kc. 15000 watts. Liberty Magazine. Announcers, Bill Hay, Tommy Coates. Daily ex Sun, 10-11 am, 12:01-12:40 pm, 7-8, 11-1. Sun, 5-6:15 pm. Central.

WLIT
Philadelphia, Pa. 405.2m-740kc. 500 watts. Lit Bros. Daily ex Sun, 12:02 pm, music; 2, music. Mon, 4:30 pm, 7:30, 8, 10. Tues, 11 am. Wed, Thurs, 4:30 pm. Wed, 7:30 pm, 8, 10, 11. Fri, 7:30 pm, 8:45, 10. Eastern.

WLS
Chicago, Ill. 344.6m-870kc. 5000 watts. Sears, Roebuck & Co. Slogan, "World's Largest Store." Daily ex Sun, 8:50-1:30 pm, half hour markets; 12-1 pm, farm program; 2:30-3:30, homemakers hour. Wed, Fri, 5:30-12 mid. Sat, 5:30-11 am. Tues, Thurs, 5:30-8 pm. Sun, 10:50-2:30 pm. U. of Chicago; 6-8, Little Brown church. Central. Founded April 6, 1924.

WLSI
Providence, R. I. 374.8m-800kc. 500 watts. Lincoln Studios Inc. Mon, 6:45 pm. Tues, 6:30 pm. Wed, 7 pm, 9. Thurs, 6:30. Fri, 7 pm. Sat, 6:30 pm. Sun, 6:30 pm. Eastern.

WLTH
Brooklyn, N. Y. 256.3m-1170kc. 250 watts. Voice of Brooklyn, Inc. Daily ex Sun, 4-7 pm. Mon, Tues, Thurs, Sat, Sun, 9-12 mid. Wed, Fri, 11-1 am. Eastern.

WLTS
Chicago, Ill. 483.6m-620kc. 100 watts. Lane Technical High School. Mon, 9-10 am, 2-4 pm, 6-7. Tues, Wed, Thurs, Fri, 9-10 am, 2-4 pm. Central.

WLW
Harrison, Ohio. 428.3m-700kc. 5000 watts. 52m-576kc. 250 watts. The Crosley Radio Corp. Announcer, Fred Smith. Daily ex Sun, 8 am, exercises; 10, woman's hour; 11, markets; 11:55, time; 12 n, music; 1:30, 3:30, markets; 6:50-12 mid. Sun, 9:30 am, 11, 3 pm, organ; 7:30-8:30, service; 8:30-11, Alterate Sun, 5:30 pm, chain. Eastern. Founded, 1919.

WLWL
New York, N. Y. 370.2m-810kc. 2000 watts. The Patlist League. Announcer, Joseph A. Bier. Slogan, "For God and Country."

WMAC
Cazenovia, N. Y. 225.4m-1330kc. 500 watts. C. B. Meredith. Announcer, C. R. Jones. Thurs, 12 n, farm program; 8 pm, popular studio. Founded 1922. Eastern.

WMAF
South Dartmouth, Mass. 416.4m-720kc. 1000 watts. Round Hills Radio Corp. Not operating.

WMAK
Buffalo, N. Y. 545.1m-550kc. 750 watts. Norton Laboratories, Inc. Announcer, William Fay. Daily ex Mon, Sun, 3:30 pm, baseball; 6:30, WGY; 7, about town; 7:15 pm, news. Tues, Thurs, Sat, 6:15-7:15 pm, dinner music. Sun, 10:25 am, church; 1:30 pm, 3:30, 7 pm, church service. Eastern. Founded Sept. 22, 1921.

WMAL
Washington, D. C. 302.8m-990kc. 250 watts. M. A. Leese Radio Co.

WMAN
Columbus, Ohio. 234.2m-1280kc. 50 watts. First Baptist church. Announcer, John Bohannan. Sun, 10:30-12 n, 7:30-9 pm. Eastern.

WMAQ
Chicago, Ill. 447.5m-670kc. 1000 watts. The Chicago Daily News. Announcer, Robert Whitney. Daily ex Sun, 6:30-11 am, 12 n-3 pm, 4-7, 8-10. Tues, Fri, 12-2 am. Wed, Sat, 1-2 am. Sun, 10:45-12 n, 7 pm, 8-10. Daily ex Sun, Sat, 12:10-12:25 pm, farm. Central.

WMAY
St. Louis, Mo. 247.8m-1210kc. 1000 watts. Kingshighway Presbyterian church. Slogan, "May Every By-Way Hear Kingshighway." Sun, 11 am, 8 pm. Central.

WMAZ
Macon, Ga. 270.1m-1110kc. 500 watts. Macon Junior Chamber of Commerce. Announcer, Milton Randolph. Mon, Wed, 1-2 pm. Tues, Thurs, 8-9 pm. Eastern.

WMB
Newport, R. I. 204m-1470kc. 100 watts. LeRoy Joseph Beebe.

WMBB
Homewood, Ill. 252m-1190kc. 5000 watts. American Bond & Mortgage Co.-Trianon. Announcer, Hugh Aspinwall. Slogan, "World's Most Beautiful Ballroom." Daily ex Sun, Mon, 6-10:30 pm. Sun, 3-6 pm, 7-10:30. Central.

WMBG
Richmond, Va. 220.4m-1360kc. 15 watts. Havens and Martin. Slogan, "The Daylight Station." Announcer, W. H. Wood. Daily ex Sun, 2-3 pm. Eastern.

WMBH
Joplin, Mo. 204m-1470kc. 100 watts. Edwin Dudley Aber. Announcers, M. E. Jones, E. D. Aber. Slogan, "Where Memories Bring Happiness." Mon, Tues, Wed, Thurs, 12:15-1 pm, 1-1:30, 5:30-7:30, 8:30-10:30. Central.

WMBI
Chicago, Ill. 263m-1140kc. 500 watts. Slogan, "The West Point of Christian Service." Daily ex Sun, 7-7:40 am, 10:30-11:30, 12:30-1:30 pm, 3:30-4:30. Daily ex Sun, Thurs, Mon, 8-9 pm. Thurs, 7-9 pm. Wed, 10-11:30 am. Sun, 3:30-7 pm. Central. Founded July 28, 1926.

WMBJ
Monessen, Pa. 232.4m-1290kc. 50 watts. Star theater. Fri, 9:45-11 pm. Eastern.

WMBL
Lakeland, Fla. 228.9m-1310kc. 50 watts. Benford's Radio studios.

WMBM
Memphis, Tenn. 209.7m-1430kc. 10 watts. Seventh Day Adventist Church.

WMBO
Auburn, N. Y. 220.4m-1360kc. 100 watts. Radio Service Laboratories.

WMBQ
Brooklyn, N. Y. 204m-1470kc. 100 watts. Paul J. Gollhofer.

WMBR
Tampa, Fla. 252m-1190kc. 100 watts. F. J. Reynolds. Daily ex Sun, 1-2 pm, 2-3, 7-8, 8-9, 10-11. Eastern.

WMBZ
Harrisburg, Pa. 234.2m-1280kc. 250 watts. Mack's Battery Co. Announcer, W. S. McCaighen. Slogan, "The Voice of the Susquehanna." Daily ex Sun, 11:30 am, music; 12 n, organ; 1 pm, women's club; 5:30, sports; 6, time, 6-11:30 pm, music. Sat, 11:30-3 am, Knut Kracker Klub frolic. Sun, 8:30 am-9 pm. Eastern. Founded March 1, 1924.

WMBU
Pittsburgh, Pa. 217.3m-1380kc. 50 watts. Paul J. Miller.

WMBW
Youngstown, Ohio. 214.2m-1400kc. 50 watts. Youngstown Broadcasting Co., Inc. Founded Jan, 1927.

WMBY
Bloomington, Ill. 199.9m-1500kc. 15 watts. Robert A. Isaacs.

WMC
Memphis, Tenn. 516.9m-580kc. 500 watts. The Commercial Appeal. Announcer, Francis S. Chamberlin. Slogan, "Station WMC, Memphis." "Down in Dixie." Club, "Midnight Frolic." Daily ex Sun, 9:45 am, 12 n, 2:30 pm, weather, markets, music. Daily, 8 pm, program; Tues, 11 pm, Midnight Frolic. Sun, 11 am, church service. Founded Jan. 20, 1923. Central.

WMCN
Hoboken, N. J. 370.2m-810kc. 500 watts. Hotel McAlpin. Announcer, Snedden Weir. Slogan, "Where the Searchlight Flashes and the White Way Begins." Daily ex Sun, Sat, 10:30 am, 1 pm, 2:45, 5, 6-1 am. Sat, 10:30-1 pm, 6-1 am. Sun, 10 am-12 mid. Eastern.

WMCO
Saginaw, Mich. 272.6m-1100kc. 250 watts. Wolverine Broadcasting Co.

WMES
Boston, Mass. 211.1m-1420kc. 100 watts. Mass. Educational Society. Founded Aug. 1, 1927.

WMPC
Lapeer, Mich. 234.2m-1280kc. 30 watts. First Methodist Protestant Church. Daily ex Sat, 12-1 pm. Daily ex Sat, Thurs, 7:30-10 pm. Sun, 10:30-12 n, 12-1 pm, 4-5:30, 7:30-10. Central. Founded Dec. 6, 1926.

WMRJ
Jamaica, N. Y. 206.8m-1450kc. 10 watts. Peter J. Prinz. Tues, Thurs, 8-11:30 pm. Sat, 12-2:30 am. Sun, 12-2:30 pm, 9-11:30. Eastern.

WMSG
New York, N. Y. 236.1m-1270kc. 500 watts. Madison Square Garden. Mon, Wed, Thurs, 9-12 mid. Tues, Fri, 6-9 pm. Eastern.

WNAC
Boston, Mass. 352.7m-850kc. 500 watts. The Shepard Stes. Announcers, John J. Fanning, Ben Hadfield, E. Lewis Dunham, Joseph Lopez, Jean Sargent. Daily ex Sun, 10:30-11:30 am, 1-2 pm, 4-5, 6-12 mid. Sun, 10:45-1:30 pm; 3-5, 7:30-11. Eastern. Founded July 31, 1922.

WNAD
Norman, Okla. 239.9m-1250kc. 500 watts. University of Oklahoma. Mon, Wed, Thurs, Sat, 7:15-8 pm. Tues, Fri, 12:15-1 pm, 2:30-3:30. Central.

WNAL
Omaha, Neb. 258.5m-1160kc. 500 watts. R. J. Rockwell. Announcer, Ronald J. Rockwell. Slogan, "Pioneer Station of Omaha." Fri, Sat, 7-9 pm, 9-11 pm. Central.

WNAT
Philadelphia, Pa. 288.3m-1040kc. 100 watts. Lennig Bros. Co. Slogan, "We Never Are Tired." Wed, 6:50 pm. Sat, 8 pm. Sun, 6:50 pm. Eastern.

WNAX
Yankton, S. D. 302.8m-990kc. 500 watts 6 am-6 pm, 250 watts after 6 pm. Gurney Seed & Nursery Co. Daily and Sun, 11 am-10 pm. Sun, 11-12 n, 2-7 pm. Central. Founded Aug. 22, 1927.

WNBA
Forest Park, Ill. 208.2m-1440kc. 200 watts. Michael J. Fafferty. Irregular hours.

WNBF
Endicott, N. Y. 206.8m-1450kc. 50 watts. Hewitt-Wood Radio Co. Irregular schedule.

WNBH
New Bedford, Mass. 260.7m-1150kc. 250 watts. New Bedford Hotel. Announcer, I. Vermilya. Tues, Thurs, 7-8 pm. Wed, 6-10 pm. Fri, 6-10:30 pm. Sun, 7:30-9 pm. Eastern.

WNBK
Knoxville, Tenn. 206.8m-1450kc. 50 watts. Lonsdale Baptist Church.

WNBL
Bloomington, Ill. 199.9m-1500kc. 15 watts. Gray, Trimble and Smith Elec. Co. Sun, 2-4 pm. Mon, 8-12 mid. Central.

WNBO
Washington, Pa. 211.1m-1420kc. 15 watts. John Brownlee Springs. Daily ex Sun, 2-4 pm, 9-11 pm. Sun, 11 am, 7 pm, services. Eastern.

WNBR
Rochester, N. Y. 202.6m-1480kc. 15 watts. Gordon P. Brown.

WNBR
Memphis, Tenn. 228.9m-1310kc. 20 watts. Popular Radio Shop. Daily ex Sun, 6:30 pm. Sun, 2:30-3 pm. Central.

WNBX
Springfield, Vt. 241.8m-1240kc. 10 watts. WNBX Broadcasters.

WNJ
Newark, N. J. 280.2m-1070kc. 500 watts. Hermon Lubinski. Announcer, W. A. Bingenheimer. Slogan, "The Voice of Newark." Tues, Wed, Fri, Sat, Sun, 6-6:30 pm, 8:30-12 midnight, dance music. Eastern.

WNOX
Knoxville, Tenn. 265.3m-1130kc. 1,000 watts. Peoples Telephone & Telegraph Co. Tues, Thurs, 7-10 pm. Sat, 9-12. Central.

WNRC
Greensboro, N. C. 223.7m-1340kc. 500 watts. Wayne M. Nelson. Founded Mar. 24, 1926.

WNYC
New York, N. Y. 526m-570kc. 500 watts. New York Municipal Radio station. Announcer, Christie R. Bohnsack. Slogan, "Municipal Broadcasting Station of the City of New York." Daily, 7-10 pm. Eastern.

WOAI
San Antonio, Tex. 302.8m-990kc. 5,000 watts. Southern Equip. Co. (Evening News-Express). Announcer, J. G. Cummings. Slogan, "The Winter Playground of America. Where the Sunshine Spends the Winter." Daily ex Sun, 10 am, weather reports, news; 12:15 pm, 3, 4, 6:15. Tues, Wed, Thurs, Fri, 8:30-9:30 pm. Fri, 9:30-10:30 pm. Sun, 11 am, service; 7:45 pm. Central. Founded summer 1922.

WOAN
Lawrenceburg, Tenn. 285.5m-1050kc. 250 watts. James D. Vaughan. Announcer, James D. Vaughan. Sun, 11-12 n, 7:30-8:30 pm. Central.

WOAX
Trenton, N. J. 239.9m-1250kc. 500 watts. F. J. Wolf. Slogan, "Trenton Makes; the World Takes." Daily ex Sun, 10 am, weather reports, news; 6-7 pm. Wed, 7:30-9 pm. Fri, 7:30-8:30 pm. Sun, 7:30-9 pm. Eastern. Founded March 2, 1923.

WOBR
Ohio. 204m-1470kc. 10 watts. Karl Smith. (Portable.)

WOBT
Union City, Tex. 205.4m-1460kc. 15 watts. Tittsworth's Radio & Music Shop.

WOBV
Charleston, W. Va. 267.7m-1120kc. 50 watts. Charleston Radio Broadcasting Co. Announcer, Wally Fredericks. Slogan, "Watch Our Business Unfold." Daily ex Sun, 7-9 pm. Wed, Sat, 11-12 mid. Eastern.

WOC
Davenport, Iowa. 374.8m-800kc. 5000 watts. The Palmer School of Chiropractic. Slogan, "Where the West Begins and in the State Where the Tail Corn Grows." Daily ex Sun, 12:27 pm, time; 12:30, markets; Tell the World Club, home hour; 5:45, chimes; 5:55, sports; Mon, 5:30 pm, WJZ; 7:05, Tues, 6:30, WEAF; 8, WEAF; 8:30, Wed, 7:30 pm, WEAF; 8:30, organ; 10, Thurs, 8 pm, 9, Fri, 7-8, WEAF; 8, Sun, 12 n, WJZ, pm, 6:30, 7:15, WEAF. Central.

WOCL
Jamestown, N. Y. 223.7m-1340kc. 25 watts. A. E. Nerston. Announcer, Roy W. Fox. Slogan, "We're on Chautauqua Lake." Mon, 9-9:15, 9:15-12 midnight. Thurs, 7-8 pm. Sun, 10:30 am, 7:30-9. Eastern.

WODA
Paterson, N. J. 293.9m-1020kc. 1000 watts. O'Dea Temple of Music. Slogan, "A Voice from the Silk City." Daily ex Sun, 12-1 pm, 5-7, 8:30-11. Founded April 13, 1925. Eastern.

WOI
Ames, Iowa. 265.3m-1130kc. 2500-5000 watts. Iowa State College. Announcer, A. G. Woollics. Daily ex Sun, 7 am, 7:30, 8:45, 9:30, 10:30, 12:10, 12:15 pm, 12:30, 12:40, 12:45, 1 pm, 1:30, 9:30. Mon, 7:30 pm, 7:45. Thurs, 7:30, 7:45, 8. Founded April, 1922. Central.

WOK
Homewood, Ill. 252m-1190kc. 5000 watts. Karzas-Chicago Beach Hotel. Announcer, Hugh Aspinwall. Daily ex Mon, 11-12:30 am. Founded July 20, 1925. Eastern.

WOKO
Peekskill, N. Y. 215.7m-1390kc. 250 watts. H. E. Smith. Daily ex Sun, 10 am. Mon, 7:30 pm, 8, 9:15. Tues, Wed, 9, 10. Thurs, 7:30 pm, 8, 9. Fri, 8:30 pm, 9. Sat, 8 pm, 9. Sun, 10:25 am, 12:15 pm, 1, 3:30. Eastern.

WOKT
Rochester, N. Y. 209.7m-1430kc. 500 watts. Titus-Ets Corp. Announcer, S. C. Hitchcock. Daily ex Sun, Mon, 11:30 am-2 pm, 6:45-10. Mon, 11:30-2 pm, 6:45-11 pm. Sun, 11-12:30 pm. Eastern.

WOMT
Manitowoc, Wis. 222.1m-1350kc. 50 watts. The Mikadov theater. Daily ex Sun, 5:30-6:50 pm. Mon, 10:30-1:30 am. Central.

WOO
Philadelphia, Pa. 508.2m-590kc. 500 watts. John Wanamaker. Daily ex Sun, 11 am, organ recital; 12:55, time; 12-1 pm, concert; 4:40, weather; 4:45, organ recital; 7:30, police reports; 10:55, time; 11:02, weather. Mon, Wed, Fri, 7:30-11 pm, music, concert. Eastern.

WOOD
Furnwood, Mich. 260.7m-1150kc. 500 watts. Walter B. Stiles, Inc. Mon, Tues, Wed, Thurs, Fri, 9-11 pm. Central.

WOQ
Kansas City, Mo. 336.9m-890kc. 500 watts. 6 am-6 pm. Unity School of Christianity. Daily ex Sun, 11-11:30 am. Mon, 6-7 pm, 9-10. Tues, 6-7 pm, Wed, 6-7 pm, 8-10. Fri, 6-7 pm, 8-10 pm. Sat, 6-7 pm, 10-11 pm. Sun, 2:30-3:30 pm, 7:45-9:30. Central. Founded 1921.

WOR
Newark, N. J. 422.3m-710kc. 5000 watts. L. Bamberger & Co. Daily ex Sun, 6:45-8 am, 2:30-4 pm. Daily and Sun, 6:15-12 mid. Founded 1922. Eastern.

WORD
Batavia, Ill. 389.4m-770kc. 5000 watts. Peoples Club association. Announcer, B. M. Rice. Slogan, "Watchtower Station WORD." Daily ex Mon, Sun, 7-10 pm. Sun, 10-12 am, 2:30-5 pm, 7-10. Founded Dec., 1924. Central.

WOS
Jefferson City, Mo. 468.5m-640kc. 500 watts. Missouri State Marketing Bureau. Announcer, Jack Reiny. Slogan, "Watch Our State." Daily ex Sun, 9 am, 10, 10:30, 11, 12 n, 1 pm, 2, markets; stocks, weather; 3:30, 4, 5, baseball, Mon, Tues, Wed, Thurs, Fri, 7 pm, markets, baseball; 7:15, news. Fri, 4 pm, children's hour. Mon, Wed, 8 pm. Fri, 8:15 pm. Central.

WOW
Omaha, Neb. 508.2m-590kc. 1000 watts. Woodmen of the World. Announcer, Lester Palmer. Slogan, "Where the West is at the Best." Daily ex Sun, 8:15 am, 8:55, 10:30, 12:30 pm, 1:45, 4, markets. Daily ex Sun, Sat, 12:45 pm. Daily ex Sun, Wed, 6-7:30, 9-11. Sun, 9-10:45 am, 1:30 pm, 2:30-4 pm, 6, 9. Founded April 2, 1923. Central.

WOWO
Fort Wayne, Ind. 228.9m-1310kc. 5000 watts. 6-6 pm. 2500 watts after 6 pm. Main Auto Supply Co. Mon, Wed, Thurs, 6-12 mid. Tues, 11 am. Wed, Thurs, 12-1 pm. Fri, 11 am, 4-5 pm, 8-10. Sat, 12-2 pm, 6-6:30 pm. Sun, 2-4 pm, 8-10. Central.

WPAP
Cliffside, N. J. 394.5m-760kc. 500 watts. Palisades Amusement Park. Announcer, Perry Charles. Mon, Wed, Sat, 8 pm. Tues, Fri, 8:30 pm. Thurs, 9 pm. Eastern.

WPCC
Chicago, Ill. 223.7m-1340kc. 500 watts. North Shore Congregational church. Announcer, Ralph E. Briggs. Wed, 7:30-8:30 pm. Fri, 7:30-9:30 pm. Sun, 3:30-5:30 pm. Central.

WPCH
New York, N. Y. 309.1m-970kc. 500 watts. Concourse Radio Corp. Mon, 7-12 mid. Tues, 4-7 pm. Wed, 6-9 pm. Thurs, 4-12 mid. Sat, 4-7 pm, 8-2 am. Sun, 6:30-12 mid. Eastern.

WPPE
Waukegan, Ill. 215.7m-1390kc. 500 watts. Announcer, Maurice Mayes. Slogan, "Waukegan Peep Station." Daily ex Mon, 3-5 pm, 6:30-9, 9:30-12. Mon, 3-5 pm. Central.

WPG
Atlantic City, N. J. 272.6m-1100kc. 5000 watts. Municipality of Atlantic City. Slogan, "World's Playgrounds." Daily ex Sun, Fri, 6:45-12:30 pm. Sun, 4:15 pm, 5:15, 9, 9:15, 10:30. Eastern.

WPRC
Harrisburg, Pa. 209.7m-1430kc. 100 watts. Wilson Printing & Radio Co. Sun, 9-11 pm. Eastern.

WPSC
State College, Pa. 299.8m-1000kc. 500 watts. Pa. State College. Slogan, "The Voice of the Nittany Lion." Mon, Wed, Fri, 8 pm. Fri, 12 mid. Eastern.

WPSW
Philadelphia, Pa. 202.6m-1480kc. 50 watts. Philadelphia School of Wireless Telegraphy. Wed, Fri, 7 pm. Eastern.

WQAA
Parkersburg, Pa. 215.7m-1390kc. 500 watts. Horace A. Beale, Jr.

WQAM
Miami, Fla. 322.4m-930kc. 750 watts. Electrical Equip. Co. Announcer, Frederick W. Mizer. Slogan, "The Most Southern Radiocasting Station in U. S." Daily ex Sun, 11:45 am. Daily ex Sun, Sat, 7-8 pm, 9-10. Sat, 7-8:30 pm. Sun, 10:45 am, 7:30 pm. Eastern. Founded Feb. 1, 1922.

WQAN
Scranton, Pa. 230.6m-1300kc. 100 watts. Scranton Times. Announcer, T. V. Nealon. Slogan, "The Voice of the Anthracite." Daily ex Sun, 12:30-1 pm, 4:30-5, news, reports, sports, music. Tues, Fri, 8 pm, entertainment. Sat, 6:30-7:15 pm, dance music. Eastern. Opened Jan. 8, 1923.

WQAO
New York, N. Y. 394.5m-760kc. 500 watts. Calvary Baptist church. Announcer, H. W. Kinsey. Slogan, "The First Church Owned and Operated Broadcasting Station in the World." Wed, 7:30 pm, church service. Sun, 11:15 am, 3 pm, 7:30, church service. Founded 1922. Eastern.

WQJ
Chicago, Ill. 447.5m-670kc. 500 watts. Calumet Baking Powder company-Chicago Daily News. Daily ex Sun, 11-12 n, 3-4 pm. Daily ex Sun, Mon, 7-8 pm, 10-2 am. Sun, 7-9:30 pm. Founded May 22, 1924. Central.

WRAF
La Porte, Ind. 208.2m-1440kc. 100 watts. Radio Club, Inc. Announcer, Charles Middleton. Slogan, "The Voice of the Maple City." Daily ex Sun, 12-1 pm, 7-9. Sun, 10:45-12:15 pm. Founded April, 1923. Central.

WRAH
Providence, R. I. 199.9m-1500kc. 250 watts. Stanley N. Read.

WRAC
Escanaba, Mich. 282.8m-1060kc. 50 watts. Economy Light Company. Announcer, H. E. Flath. Slogan, "The Gateway to Cloverland." Mon, Fri, 8:30 pm. Eastern.

WRAM
Galesburg, Ill. 247.8m-1210kc. 50 watts. Lombard College. Mon, 7-11 pm. Founded 1922. Central.

WRAV
Yellow Springs, Ohio. 340.7m-880kc. 100 watts. Antioch College. Announcer, Charles W. Putman. Thurs, 9 pm, music; 9, educational. Sun, 7 pm. Central.

WRAW
Reading, Pa. 238m-1260kc. 100 watts. Avenue Radio & Elec. Shop. Slogan, "The Schuylkill Valley Echo." Announcer, C. M. Chaiey. Tues, 9-11 pm. Thurs, 10-12 mid. Sun, 11 am, 1:30-2:30 pm, 3-4. Eastern. Founded June 5, 1923.

WRAX
Philadelphia, Pa. 212.6m-1410kc. 250 watts. Bereah Church, Inc. Tues, Thurs, 7:30-9:30 pm. Sun, 11:15-12:15 pm, 4-5. Eastern.

WRBC
Valparaiso, Ind. 238m-1260kc. 250 watts. Immanuel Lutheran church. Announcer, A. Z. Arehart. Slogan, "World Redeemed by Christ." Mon, 7:30 pm. Sun, 7:30 pm, church service. Central. Founded March, 1924.

WRC
Washington, D. C. 468.5m-640kc. 500 watts. Radio Corp. of America. Announcer, John B. Daniel. Slogan, "The Voice of the Capitol." Daily ex Sun, 6:45 am-1 pm, WEAF; 1-2, organ; 5-11 pm. Sun, 11 am-9:30 pm. Eastern.

WRCO
Raleigh, N. C. 217.3m-1380kc. 250 watts. Wynne Radio Co. Sun, 10:45 am; 1 pm. Eastern.

WRCV
Norfolk, Va. 209.7m-1430kc. 100 watts. Radio Corporation of Virginia. Slogan, "The Voice of the Business District." Wed, Fri, Sat, 7:30-9 pm. Sun, 10:30-12:15 pm, 7:15-8:45. Eastern.

WREC
Memphis, Tenn. 254.1m-1180kc. 50 watts. WREC Inc. Daily ex Sun, 8-9 pm. Sun, 4-5:30 pm. Central.

WREN
Lawrence, Kan. 254.1m-1180kc. 750 watts. Jenny Wren. Daily ex Sun, 10:45 am, women's hour. Central.

WLBZ
Foxcroft, Me. 208.2m-1440kc. 250 watts. Thompson L. Guernsey.

WLCI
Ithaca, N. Y. 247.8m-1210kc. 50 watts. Lutheran Radio of Ithaca. Announcer, Robert F. Schuetz. Slogan, "The Church at the Gate of the Campus." Sun, 10:45 am, 7:45 pm. Eastern.

WLIB
Elgin, Ill. 305.9m-980kc. 15000 watts. Liberty Magazine. Announcers, Bill Hay, Tommy Coates. Daily ex Sun, 10-11 am, 12:01-12:40 pm, 7-8, 11-1. Sun, 5-6:15 pm. Central.

WLIT
Philadelphia, Pa. 405.2m-740kc. 500 watts. Lit Bros. Daily ex Sun, 12:02 pm, music; 2, music. Mon, 4:30 pm, 7:30, 8, 10. Tues, 11 am. Wed, Thurs, 4:30 pm. Wed, 7:30 pm, 8, 10, 11. Fri, 7:30 pm, 8:45, 10. Eastern.

WLS
Chicago, Ill. 344.6m-870kc. 5000 watts. Sears, Roebuck & Co. Slogan, "World's Largest Store." Daily ex Sun, 8:50-1:30 pm, half hour markets; 12-1 pm, farm program; 2:30-3:30, homemakers hour. Wed, Fri, 5:30-12 mid. Sat, 5:30-11 am. Tues, Thurs, 5:30-8 pm. Sun, 10:50-2:30 pm. U. of Chicago; 6-8, Little Brown church. Central. Founded April 6, 1924.

WLSI
Providence, R. I. 374.8m-800kc. 500 watts. Lincoln Studios Inc. Mon, 6:45 pm. Tues, 6:30 pm. Wed, 7 pm, 9. Thurs, 6:30. Fri, 7 pm. Sat, 6:30 pm. Sun, 6:30 pm. Eastern.

WLTH
Brooklyn, N. Y. 256.3m-1170kc. 250 watts. Voice of Brooklyn, Inc. Daily ex Sun, 4-7 pm. Mon, Tues, Thurs, Sat, Sun, 9-12 mid. Wed, Fri, 11-1 am. Eastern.

WLTS
Chicago, Ill. 483.6m-620kc. 100 watts. Lane Technical High School. Mon, 9-10 am, 2-4 pm, 6-7. Tues, Wed, Thurs, Fri, 9-10 am, 2-4 pm. Central.

WLW
Harrison, Ohio. 428.3m-700kc. 5000 watts. 52m-576kc. 250 watts. The Crosley Radio Corp. Announcer, Fred Smith. Daily ex Sun, 8 am, exercises; 10, woman's hour; 11, markets; 11:55, time; 12 n, music; 1:30, 3:30, markets; 6:50-12 mid. Sun, 9:30 am, 11, 3 pm, organ; 7:30-8:30, service; 8:30-11, Alterate Sun, 5:30 pm, chain. Eastern. Founded, 1919.

WLWL
New York, N. Y. 370.2m-810kc. 2000 watts. The Patlist League. Announcer, Joseph A. Bier. Slogan, "For God and Country."

WMAC
Cazenovia, N. Y. 225.4m-1330kc. 500 watts. C. B. Meredith. Announcer, C. R. Jones. Thurs, 12 n, farm program; 8 pm, popular studio. Founded 1922. Eastern.

WMAF
South Dartmouth, Mass. 416.4m-720kc. 1000 watts. Round Hills Radio Corp. Not operating.

WMAK
Buffalo, N. Y. 545.1m-550kc. 750 watts. Norton Laboratories, Inc. Announcer, William Fay. Daily ex Mon, Sun, 3:30 pm, baseball; 6:30, WGY; 7, about town; 7:15 pm, news. Tues, Thurs, Sat, 6:15-7:15 pm, dinner music. Sun, 10:25 am, church; 1:30 pm, 3:30, 7 pm, church service. Eastern. Founded Sept. 22, 1921.

WMAL
Washington, D. C. 302.8m-990kc. 250 watts. M. A. Leese Radio Co.

WMAN
Columbus, Ohio. 234.2m-1280kc. 50 watts. First Baptist church. Announcer, John Bohannan. Sun, 10:30-12 n, 7:30-9 pm. Eastern.

WMAQ
Chicago, Ill. 447.5m-670kc. 1000 watts. The Chicago Daily News. Announcer, Robert Whitney. Daily ex Sun, 6:30-11 am, 12 n-3 pm, 4-7, 8-10

WRES

Quincy, Mass. 217.3m-1380kc. 50 watts. Harry Leonard Sawyer. Tues, Wed, Thurs, Fri, 8-11 pm. Eastern.

WRHF

Washington, D. C. 319m-940kc. 150 watts. Washington Radio Hospital fund. Daily ex Sun, 11-12 n, news, police reports. Founded 1924. Eastern.

WRHM

Minneapolis, Minn. 260.7m-1150kc. 1000 watts. Rosedale Hospital, Inc. Announcer, Troy S. Miller. Daily ex Sun, 9:10-30 am, 5:45-6 pm, 6-7. Mon, Wed, Fri, 8-10 pm. Thurs, 10-12 mid. Sat, 6-11 pm. Sun, 2-6 pm, 6-12 mid. Central.

WRK

Hamilton, Ohio. 205.4m-1460kc. 100 watts. WRK Broadcasters. Daily ex Sun, 1:30-2:30 pm; 7:30-10:30. Central. Founded 1919.

WRM

Urbana, Ill. 272.6m-1100kc. 500-1000 watts. Univ. of Ill. Announcer, John Bayles. Daily ex Sun, 5-6 pm. Tues, 7-8 pm, musical. Sun, 4 pm, organ. Central.

WRMU

New York, N. Y. 201.2m-1490kc. 100 watts. A. H. Grebe & Co., Inc. Motor Yacht "MU-1."

WRNY

Coytesville, N. Y. 309.1m-970kc. 500 watts. Experimenting Pub. Co. Daily ex Sun, 11-1 pm, 2:30-4, 7-11 pm. Sun, 11 am, 1-6:30 pm. Eastern. Founded June 12, 1925.

WRPI

Terre Haute, Ind. 208.2m-1440kc. 100 watts. Rose Polytechnic Institute Broadcasting Assn.

WRR

Dallas, Texas. 352.7m-850kc. 500 watts. City of Dallas. Announcer, John Thorwald. Slogan, "City of Achievements." Daily ex Sun, Wed, 12-1 pm, 6-7, 8-9. Mon, 9:30-10:30 pm, 11-12 midnight. Wed, 6:55 pm. Thurs, 9-10 pm, 11-12. Fri, 8-10 pm. Sun, 11-12 n; 6:55, police; 8, church; 9:30, music. Central.

WRRS

Racine, Wis. 322.4m-930kc. 50 watts. Racine Broadcasting Corp. Announcer, F. G. Leavenworth. Daily ex Sun, Sat, 6-7 pm, news. Mon, Wed, Fri, 12-1 pm, organ. 7:30-10:30 pm. Central. Founded Dec. 15, 1926.

WRSC

Chelsea, Mass. 211.1m-1420kc. 100 watts. The Radio Shop.

WRST

Bay Shore, N. Y. 211.1m-1420kc. 250 watts. Radiotele Mfg. Co., Inc. Slogan, "Bay Shore, the Garden Spot of Long Island." Daily ex Sun, 5:45-6:30 pm, 7-11. Sun, 10-12 m, 8-11. Eastern.

WRVA

Richmond, Va. 254.1m-1180kc. 1000 watts. Larus & Bro. Co., Inc. Slogan, "Garry Me Back to Old Virginia." Announcer, Elmer Hoesel. Mon, Wed, Thurs, Fri, 12-1:30 pm; 7-12 mid. Daily ex Sat, Sun, 11 am, 8 pm. Founded Nov. 2, 1925. Eastern.

WSAI

Mason, Ohio. 361.2m-830kc. 5000 watts. United States Playing Card Co. Daily and Sun, 7-12 mid. Fri, 8-9 pm. Eastern.

WSAJ

Grove City, Pa. 223.7m-1340kc. 250 watts. Grove City College. William L. Harman, activities. Irregular schedule. Founded Nov., 1921.

WSAN

Allentown, Pa. 222.1m-1350kc. 100 watts. Allentown Call Pub. Co. Announcer, Charles Walp. Tues, Thurs, 8:15 pm. Eastern.

WSAR

Fall River, Mass. 252m-1190kc. 100 watts. Doughty & Welch Elec. Co., Inc. Announcer, Barton G. Albert. Daily ex Sun, 9-10 pm. Eastern.

WSAX

Chicago, Ill. 204m-1470kc. 100 watts. Zenith Radio Corp.

WSAZ

Huntington, W. Va. 241.8m-1240kc. 100 watts. McKellar Elec. Co. Announcer, Glenn E. Chase. Daily ex Sun, 12-4 pm, 6-10. Sun, 10-12:30 pm, 3-4, 6-10. Eastern. Founded Feb., 1927.

WSB

Atlanta, Ga. 475.9m-630kc. 1000 watts. Atlanta Journal. Announcer, Lambdin Kay. Slogan, "The Voice of the South." Daily ex Sun, 10 am, home-makers half hour; 12-1 pm, music, weather; 1, farm service; 2, concert, reports; 3:30, baseball; 8-9, concert; 10:45-12, music. Mon, 5:30 pm, WJZ. Tues, 7 pm, WEAF. Wed, 6:15 pm, health talk; 7, WJZ. Sat, 6 pm, S. J. Jesson. Sun, 9:30 am, 10:54, 5 pm, 6:15, WEAF; 8:15, music. Central.

WSBC

Chicago, Ill. 232.4m-1290kc. 500 watts. World Battery Co. Daily ex Sun, Mon, Thurs, 6:30-8 pm. Daily ex Mon, 9-1 am. Sat, 2-4 am. Sun, 5-7 pm. Thurs, 6-7 pm. Central.

WSBF

St. Louis, Mo. 440.9m-680kc. 250 watts. WSBF Broadcasters.

WSBT

South Bend, Ind. 238m-1260kc. 500 watts. South Bend Tribune. Announcer, C. G. Livengood. Mon, 8-10 pm, 12-1:30 pm. Wed, Fri, 8-10 pm. Founded 1922. Central.

WSDA

New York, N. Y. 227.1m-1320kc. 250 watts. City Temple. Thurs, 7:45-9:30 pm. Sat, 10:45-11 pm. Sun, 7:30-9:30 pm. Eastern.

WSEA

Virginia Beach, Va. 263m-1140kc. 500 watts. Virginia Beach Broadcasting Co. Announcer, George L. Sutherland. Slogan, "The Voice of Tidewater Virginia." Daily ex Sun, 11-1 pm, 1-3, 6:15-7:10 pm, 7-8, 8-9, 9-12 mid. Sun, 7-10 pm. Eastern.

WSIX

Springfield, Tenn. 212.6m-1410kc. 150 watts. 638 Tire and Vulc. Co. Announcer, George H. Lawrence. Daily ex Sun, 12:30-1:30 pm, 7-9. Sun, 11 am. Central. Founded Jan. 7, 1927.

WSKC

Bay City, Mich. 374.8m-800kc. 250 watts. World's Star Knitting Co. Announcer, S. F. Northcott. Slogan, "Where the Summer Trails Begin." Daily ex Sun, 12-1 pm; 4, Mon, 9-11 pm, 12-2 am. Wed, 9-11 pm. Sat, 10-11 pm. Sun, 11 am. Eastern. Founded June 15, 1925.

WSM

Nashville, Tenn. 340.7m-880kc. 5000 watts. National Life and Accident Insurance Company. Announcer, George Hay. Daily ex Sun, Sat, 11:45 am, 12:30 pm, 1-1:30. Mon, 5:30-11 pm. Tues, 6-10 pm. Wed, 6-10 pm. Thurs, 7-11 pm. Sat, 7-11 pm. Sun, 11 am, 1-4:45 pm, alternate services. Founded Oct. 5, 1925. Central.

WSMB

New Orleans, La. 322.4m-930kc. 500 watts. Saenger Theaters, Inc., and The Maison Blanche Co. Daily ex Sun, 12:30-1:30 pm, 6-7 pm. Mon, Wed, Thurs, Sat, 8:30-10:30 pm. Founded April 21, 1925. Central.

WSMK

Dayton, Ohio. 296.9m-1010kc. 200 watts. S. M. Krohn, Jr. Slogan, "The Home of Aviation." Daily ex Sun, Thurs, 12-1 pm, 6-7, 8-10. Sat, 12-3 am. Sun, 10:45-12 n, 7:30-9 pm. Central.

WSOE

Milwaukee, Wis. 270.1m-1110kc. 500 watts. School of Engineering of Milwaukee. Slogan, "In the Land of the Sky-blue Waters." Daily ex Sun, 2:30-3:30 pm, matinee; 5:13-5:50, weather, Peter Rabbit; 5:50, library talk; 6:10, organ; 8-11, concert. Fri, 11-12 am, Victor hour. Fri, 7:45-8 pm, library talk. Sun, 3:30-4:30 pm, Bible class; 7:30-8:30, church. Central. Founded Sept. 21, 1922.

WSRO

Middletown, Ohio. 384.4m-780kc. 100 watts. Radio Co. Announcer, Harry W. Fahrlander. Slogan, "We Sell Radio Only." Tues, Fri, 10:30-11 am, 8-10 pm. Sun, 2-4 pm. Central.

WSSH

Boston, Mass. 288.3m-1040kc. 100 watts. Tremont Temple Baptist Church. Announcer, Raymond B. Meader. Fri, 7:30-9 pm. Sun, 10 am, 6:30 pm. Eastern. Founded June 8, 1924.

WSUI

Iowa City, Iowa. 422.3m-710kc. 500 watts. Univ. of Iowa. Announcer, Carl Menzer. Daily ex Sun, 9 am, 10:30. Daily ex Sat, Sun, 12:25 pm, 3:30. Mon, 8 pm, 9, 11. Wed, 8 pm. Sun, 9:30 pm. Mon, 11:15 pm. Sat, 7:30 pm. Sun, 9 pm. Founded Feb. 12, 1924. Central.

WSVS

Buffalo, N. Y. 205.4m-1460kc. 50 watts. Seneca Vocational School. David Warahof, announcer. Slogan, "Watch Seneca Vocational School." Founded Nov. 9, 1925.

WSYR

Syracuse, N. Y. 225.4m-1330kc. 500 watts. Clive B. Meredith. Announcer, Pierre Pouchot. Slogan, "Voice of Central New York." Daily ex Sun, Thurs, 6:20-10:30 pm. Eastern. Founded 1922.

WTAD

Quincy, Ill. 236.1m-1270kc. 250 watts. Illinois Stock Medicine Broadcasting Corporation. Slogan, "The Voice of Agriculture." Daily ex Sun, 11:30-12:30 pm. Central. Founded Dec. 29, 1926.

WTAG

Worcester, Mass. 516.9m-580kc. 500 watts. Worcester Telegram Gazette. Announcer, Chester Gaylord. Slogan, "The Voice from the Heart of the Commonwealth." Daily ex Sun, Sat, 10:30 am, 12:30, 12:35, 1 pm, 7:30, 8, 8:30, 9, 10, 11. Sat, 12 n, 1 pm. Sun, 5:30, 7:20-10:15 pm. Eastern.

WTAL

Toledo, Ohio. 280.2m-1070kc. 100 watts. The Toledo Broadcasting Co. Announcer, Karl Brinke. Slogan, "The Gateway to the Sea." Daily, 8 pm. Sat, 9 pm. Sun, 3 am. Eastern.

WTAM

Cleveland, Ohio. 399.8m-750kc. 3500 watts. Willard Storage Battery Co. Announcer, R. B. Humphrey. Slogan, "The Voice from the Storage Battery." Daily ex Sun, 12:35 pm, 6-12 mid. Tues, 1:30 pm, heavy talk. Sun, 11 am, service; 3:30 pm, musicale; 6, 7, 8, 9, 10. Founded Sept. 26, 1923. Eastern.

WTAQ

Eau Claire, Wis. 254.1m-1180kc. 500 watts. Gillette Rubber Co. Announcer, C. S. Van Gorden. Slogan, "The Voice of the Wilderness." Mon, 12:15 pm, weather, news, markets; 6, 6:30, 7:30, 10. Tues, 12 n, 6 pm, 9. Wed, 12:15 pm, 6, 6:30. Thurs, 12:15 pm, 6, 9, 10. Fri, 12 n, 6, 8. Sat, 12:15 pm. Sun, 11 am. Central. Founded Oct. 12, 1922.

WTAR

Norfolk, Va. 236.1m-1270kc. 500 watts. Reliance Electric Co. Announcer, J. K. Bohannon. Slogan, "Down in Old Virginia." Daily ex Sun, 6:30 pm, weather, markets, news. Tues, 8-9 pm, music. Eastern.

WTAS

Chicago, Ill. 288.3m-1040kc. 1500 watts. Illinois Broadcasting Corp.

WTAW

College Station, Tex. 309.1m-970kc. 500 watts. Agricultural and Mechanical College of Texas. Daily ex Sun, Sat, 12:15 pm. Founded 1922. Central.

WTAX

Streator, Ill. 322.4m-930kc. 50 watts. Williams Hardware Co. Radio Division. Announcer, N. B. Williams. Slogan, "Tappa Kegga Nails." Tues, 7-8 pm. Thurs, 8-12 mid. Sat, 8:30-10 pm. Central.

WTAZ

Lambertville, N. J. 220.4m-1360kc. 15 watts. W. Reynolds, Jr. & T. J. McQuire.

WTFF

Mt. Vernon Hills, Va. 204m-1470kc. 50 watts. Independent Pub. Co.

WTFI

Toccoa, Ga. 209.7m-1430kc. 250 watts. Toccoa Falls Institute.

WTHS

Atlanta, Ga. 227.1m-1320kc. 200 watts. Atlanta Technological High School.

WTIC

Hartford, Conn. 535.4m-560kc. 500 watts. The Travelers Insurance Company. Slogan, "The Insurance City." Daily, 6:30-11 pm. Sat, Old Gold program. Sun, 4:30-7:30 pm. Founded Feb. 10, 1924. Eastern.

WTMJ

Milwaukee, Wis. 293.9m-1020kc. 1000 watts. Milwaukee Journal. Announcers, Nate Caldwell, Larry Teich. Slogan, "Voice of Wisconsin, Land of Lakes." Daily ex Sun, 9:45 am-12:30 pm, 5:40-6 pm. Mon, Tues, Wed, 2-12 mid. Thurs, Fri, Sat, 2-10 pm. Sat, 7:30 pm. Sun, 11 am-10 pm. Central.

WTRC

Brooklyn, N. Y. 204m-1470kc. 50 watts. Richard Weber. Announcer, Bob Rohrig. Daily ex Sun, 7:30-11:30 pm. Sun, 10:30-12:15 pm. Sat, 2-5 pm. Eastern.

WTRL

Midland Park, N. J. 206.8m-1450kc. 15 watts. Technical Radio Laboratory.

WWAE

Chicago, Ill. 227.1m-1320kc. 500 watts. Dr. George F. Courrier. Daily ex Sun, Mon, 7-9 pm. Central.

WWJ

Detroit, Mich. 352.7m-850kc. 1000 watts. The Detroit News. Announcer, E. L. Tyson, F. P. Wallace. Mon, Wed, Fri, 9:30-9:45, household hints; 10:25-10:30, weather; 11:55-12, time; 12:05-12:45 pm, music; 4, music. Daily ex Sat, Sun, 6-7, dinner concert, Mon, 7:30 pm, WEAF; 9, WEAF. Tues, 7 pm, WEAF. Wed, 7:30 pm, music; 8:30, WEAF; 9:30, WEAF. Thurs, 7 pm, WEAF. Fri, 7 pm, WEAF. 8, musicale; 8:30, WEAF; 9, WEAF; 9:30, WEAF. Sun, 11 am, 7:20 pm, WEAF; 9:15, WEAF. Eastern. Founded Aug., 1920.

WWL

New Orleans, La. 275.1m-1090kc. 100 watts. Loyola Univ. Announcer, O. L. Abell. Sat, 7:30-8:30 pm. Central. Founded March 31, 1922.

WWNC

Asheville, N. C. 296.9m-1010kc. 1000 watts. Asheville Chamber of Commerce. Daily ex Sun, 1 pm, 2, 7-8. Mon, 8-12 mid. Thurs, 8-10:45 pm. Sun, 11 am, 8 pm. Eastern.

WWRL

Woodside, N. Y. 267.7m-1120kc. 100 watts. W. H. Reuman.

WWVA

Wheeling, W. Va. 389.4m-770kc. 100 watts. John C. Stroebel, Jr. Daily ex Sun, 6:45-7:45 am, 2 pm, 6. Mon, 7-11 pm. Sat, 11-1 am. 2 pm. Eastern. Founded Dec. 6, 1926.

Canada

CFAC

Calgary, Alta., Can. 434.5m-690kc. 500 watts. Calgary Herald. Announcer, Fred Carleton. Daily ex Sun, 1:15 pm, weather, markets. Mon, 3:30-4:30 pm; 9:30-10:30. Tues, 6-7 pm. Wed, 3:30-4:30 pm; 7:45-8:45. Thurs, 9 pm. Mountain. Founded May 4, 1922.

CFCA

Toronto, Ont., Can. 356.9m-840kc. 500 watts. Toronto Star. Announcer, Gordon W. McClain. Daily ex Sun, 12 n, 5:20, 6:30, weather, stocks. Mon, 6:30-8 pm. Wed, 8-12 mid. Thurs, 8-9 pm, 10:30-12 mid. Sat, 8-10 pm. Sun, 11 am, 7 pm. Eastern. Founded March, 1922.

CFCF

Montreal, P. Q., Can. 410.7m-730kc. 1650 watts. Canadian Marconi Co. Announcer, C. Walter Darling. Daily ex Sun, 12:45-1:40 pm, stocks, music. Mon, Fri, 7-7:30 pm, bedtime stories; 7:30-8:30, music; 9-10, 10:30-11:30, orchestra. Wed, 7-8 pm, orchestra. Eastern.

CFCH

Iroquois Falls, Ont. 499.7m-600kc. 250 watts. Abitibi Power and Paper Co., Ltd.

CFCN

Calgary, Alta., Can. 434.5m-690kc. 1800 watts. W. W. Grant, Ltd. Slogan, "Voice of the Prairies." Tues, 9-10 pm. Wed, 9-10 pm, 11-12. Thurs, 7:45-8:45 pm. Fri, 9-10 pm. Sun, 11 am, 7:15 pm, services, 3 pm. Mountain.

CFCQ

Vancouver, B. C. 410.7m-730kc. 100 watts. Sprott-Shaw Radio Co.

CFCT

Victoria, B. C., Can. 475.9m-630kc. 500 watts. The Deaville Station. Slogan, "The Mecca of Tourists." Wed, 9-10 pm. Every second Thurs, 10:30 pm, 12 mid. Night Birds. Sat, Mon, 6:30-7:30 pm, 10-11. Sun, 11 am, 7:30 pm. Pacific. On air Mar, 1924.

CFCY

Charlottetown, P. E. I. 312.3m-960kc. 100 watts. Island Radio Co. Wed, Thurs, 7-8 pm. Sun, 11 am, 7 pm.

CFGC

Brantford, Ont. 296.9m-1010kc. 50 watts. Brant Radio Supply Co., Ltd. Daily ex Sun, 7-9 pm. Sun, services. Eastern.

CFJC

Kamloops, B. C. 267.7m-1120kc. 15 watts. N. S. Dalgleish and Sons, Weller and Weller.

CFLC

Prescott, Ont. 296.9m-1010kc. 50 watts. Radio Association of Prescott.

CFMC

Kingston, Ont., Can. 267.7m-1120kc. 20 watts. Monarch Battery Mfg. Co., Ltd.

CFNB

Fredericton, N. B. 247.8m-1210kc. 25 watts. James S. Neill & Sons, Ltd.

CFQC

Saskatoon, Sask., Can. 329.5m-910kc. 500 watts. The Electric Shop, Ltd. Announcer, Grant Stevenson. Slogan, "The Hub City of the West Where No. 1 Northern Hard Wheat Grows." Daily ex Sun, 9-10 am, 1:15-2 pm, markets, reports, music. Wed, 8-10 pm. Fri, 9-11:30 pm, dance program. Sun, 11 am, 7 pm, church service. Mountain.

CFRB

Township of King, York County, Ont. 291.1m-1030kc. 1000 watts. Standard Radio Mfg. Corp., Ltd.

CFRC

Kingston, Ont., Can. 267.7m-1120kc. 500 watts. Queen's University.

CFYC

Vancouver, B. C. 410.7m-730kc. 500 watts. International Bible Students' Assn.

CHCS

Hamilton, Ont., Can. 340.7m-880kc. 10 watts. Hamilton Spectator. Announcer, H. Earnshaw. Daily ex Sun, 6:45 pm, news, markets, baseball. Sat, 10-12 midnight, dance. Sun, 11 am, 7 pm. Eastern.

CHCY

King Edward Park, Edmonton, 516.9m-580kc. 250 watts. International Bible Students' Association. Tues, Thurs, Sat, 8:30-10 pm. Sun, 10-11 am, 3-4 pm, 9:15-10:30. Eastern. Founded May 11, 1926.

CHGS

Summerside, P. E. I. 267.7m-1120kc. 50 watts. R. T. Holman, Ltd. Daily ex Sun, 12 n. Sun, 11 am, 7 pm.

CHIC

Toronto, Can. 356.9m-840kc. 500 watts. Northern Electric Company Ltd. Announcer, R. W. Lowman. Mon, 8-9 pm, 11-1 am. Sat, 10-11 am, 8-9 pm, 10-12 mid. Sun, 5-6 pm. Eastern.

CHMA

Edmonton, Alta. 516.9m-580kc. 250 watts. Christian & Missionary Alliance.

CHNC

Toronto, Can. 356.9m-840kc. 500 watts. Toronto Radio Research society.

An Evening at Home With the Listener In

IN CENTRAL TIME

IN EASTERN TIME

Call	Met.	Kc.	Watts	Saturday	Sunday	Monday	Tuesday	Wed.	Thursday	Friday	Call	Location	Met.	Kc.	Watts	Saturday	Sunday	Monday	Tuesday	Wed.	Thursday	Friday		
CFCM	356.9	840	500	Silent	7:00-7:15	6:15-8:15	Silent	7:00-11:45	6:25-9:30	Silent	CFCM	Toronto	356.9	840	500	Silent	8:00-10:15	7:15-9:15	Silent	8:00-12:45	7:25-10:30	Silent		
CJRM	296.9	1010	500	11:30-12:30	Silent	7:30-10:00	Silent	7:30-10:00	Silent	7:30-10:00	CJRM	Moosajaw	296.9	1010	500	12:30-1:30	Silent	8:30-11:00	Silent	8:30-11:00	Silent	9:30-10:30	Silent	
CKCL	356.9	840	5000	6:00-7:00	Silent	7:00-8:00	Silent	8:00-10:00	8:30-9:30	Silent	CKCL	Toronto	356.9	840	5000	7:00-8:00	Silent	8:00-9:00	Silent	8:00-12:00	Silent	10:00-11:00	Silent	
CKNC	356.9	840	500	Silent	Silent	7:00-8:00	Silent	8:00-10:00	8:30-9:30	Silent	CKNC	Toronto	356.9	840	500	8:30-11:30	Silent	8:30-12:00	Silent	9:00-1:00	8:30-10:00	Silent		
CKY	384.4	780	500	7:30-10:30	Silent	7:30-10:00	Silent	8:00-10:00	8:30-9:30	Silent	CKY	Winnipeg	384.4	780	500	Silent	8:00-9:00	Silent	8:00-12:00	Silent	9:00-1:00	8:30-10:00	Silent	
CNRO	434.5	690	500	Silent	Silent	7:00-11:00	Silent	8:00-10:00	8:30-9:30	Silent	CNRO	Ottawa	434.5	690	500	Silent	8:00-9:00	Silent	8:00-12:00	Silent	9:00-1:00	8:30-10:00	Silent	
CYH	311	960	250	Silent	9:30-11:00	Silent	Silent	9:30-11:30	Silent	9:30-10:30	CYH	Monterey	311	960	250	Silent	10:30-12:00	Silent	10:30-12:30	Silent	10:30-11:00	10:30-11:30	Silent	
KDKA	315.6	950	10000	9:00-10:00	Silent	9:00-10:00	9:00-10:00	9:00-10:00	9:00-10:00	9:00-10:00	KDKA	Mexico City	315.6	950	10000	10:00-11:00	Silent	10:00-11:00	10:00-11:00	10:00-11:00	10:00-11:00	10:00-11:00	10:00-11:00	
KFBAB	309.1	970	2000	8:30-10:00	9:00-10:00	8:30-10:15	8:05-10:30	8:30-10:30	Silent	8:30-10:00	KFBAB	Lincoln	309.1	970	2000	9:30-11:00	10:00-11:00	9:30-11:15	9:05-11:30	9:30-11:30	Silent	9:30-11:00		
KFD	374.8	800	500	Silent	8:00-9:00	Silent	8:00-10:00	Silent	8:00-10:00	Silent	KFD	Beaumont	374.8	800	500	9:00-10:00	9:00-10:00	Silent	9:00-10:00	Silent	Silent	Silent	9:30-11:00	
KFH	245.8	1220	500	7:30-8:30	8:00-9:00	7:30-8:30	8:15-1:00	8:15-1:00	8:15-1:00	8:15-1:00	KFH	Wichita	245.8	1220	500	8:30-9:00	8:00-9:00	8:30-9:30	8:30-9:30	8:30-9:30	8:30-9:30	8:30-9:30	8:30-9:30	
KFT	468.5	640	5000	5:00-6:00	8:00-12:00	8:15-1:00	8:15-1:00	8:15-1:00	8:15-1:00	8:15-1:00	KFT	Los Angeles	468.5	640	5000	9:30-3:00	9:00-1:00	9:15-2:00	9:15-2:00	9:15-2:00	9:15-2:00	9:15-2:00	9:15-2:00	
KJF	471.3	650	2000	7:15-2:00	1:30-9:00	7:15-8:30	7:15-8:30	7:15-8:30	7:15-8:30	7:15-8:30	KJF	Oklahoma City	471.3	650	2000	8:15-3:00	2:30-10:00	8:15-9:30	8:15-9:30	8:15-9:30	8:15-9:30	8:15-9:30	8:15-9:30	
KJNF	461.3	650	2000	5:00-7:00	6:00-7:00	5:00-7:00	5:00-7:00	5:00-7:00	5:00-7:00	5:00-7:00	KJNF	Shenandoah	461.3	650	2000	9:00-12:00	9:00-12:00	9:00-12:00	9:00-12:00	9:00-12:00	9:00-12:00	9:00-12:00		
KFOA	447.8	670	1000	10:00-11:00	Silent	8:00-11:00	8:00-11:00	8:00-12:00	8:00-12:00	8:00-12:00	KFOA	Seattle	447.8	670	1000	11:00-12:00	Silent	9:00-3:00	9:00-3:00	9:00-3:00	9:00-3:00	9:00-3:00	9:00-3:00	
KFON	241.9	1240	500	8:00-2:00	8:00-2:00	8:00-2:00	8:00-2:00	8:00-2:00	8:00-2:00	8:00-2:00	KFON	Long Beach	241.9	1240	500	9:00-3:00	Silent	9:00-3:00	9:00-3:00	9:00-3:00	9:00-3:00	9:00-3:00	9:00-3:00	
KFRU	449.9	1200	500	Silent	Silent	6:15-7:15	6:15-7:15	6:15-7:15	6:15-7:15	6:15-7:15	KFRU	Colombia	449.9	1200	500	Silent	Silent	7:15-8:15	7:15-8:15	7:15-8:15	7:15-8:15	7:15-8:15	7:15-8:15	
KFSD	243.9	680	500	6:00-12:00	2:00-9:00	6:00-9:00	6:00-9:00	6:00-9:00	6:00-9:00	6:00-9:00	KFSD	San Diego	243.9	680	500	7:00-1:00	3:00-10:00	7:00-10:00	7:00-10:00	7:00-10:00	7:00-10:00	7:00-10:00	7:00-10:00	
KFUO	545.1	550	500	7:15-8:15	9:15-10:15	8:00-9:00	6:30-7:30	9:30-10:30	Silent	7:15-8:15	KFUO	St. Louis	545.1	550	500	8:15-9:15	10:15-11:15	9:00-10:00	7:30-8:30	9:00-10:00	8:00-1:00	8:00-1:00	8:00-1:00	
KFVE	234.2	1280	1000	7:00-10:00	6:45-12:00	7:00-12:00	7:00-12:00	7:00-12:00	Silent	7:00-12:00	KFVE	St. Louis	234.2	1280	1000	9:00-2:00	11:30-2:00	9:00-2:00	9:00-2:00	9:00-2:00	9:00-2:00	9:00-2:00	9:00-2:00	
KFWB	367.2	830	500	8:00-2:00	10:30-1:00	8:00-2:00	8:00-2:00	8:00-2:00	8:00-2:00	8:00-2:00	KFWB	Hollywood	367.2	830	500	11:00-5:30	10:50-12:00	9:00-3:00	9:00-3:00	9:00-3:00	9:00-3:00	9:00-3:00	9:00-3:00	
KFWI	261.7	1120	500	10:00-3:00	8:30-12:00	8:00-2:00	8:00-1:00	8:00-12:00	8:00-12:00	8:00-12:00	KFWI	Spokane	261.7	1120	500	Silent	10:50-12:00	9:00-12:00	9:00-12:00	9:00-12:00	9:00-12:00	9:00-12:00	9:00-12:00	
KGA	360.7	1150	2000	Silent	9:50-11:00	8:00-11:00	8:00-11:00	8:00-11:00	8:00-11:00	8:00-11:00	KGA	Oakland	360.7	1150	2000	11:00-4:00	9:30-1:00	9:00-12:20	9:00-12:20	9:00-12:20	9:00-12:20	9:00-12:20	9:00-12:20	
KGO	284.4	610	2000	10:00-11:00	9:30-1:00	8:00-2:00	8:00-2:00	8:00-2:00	8:00-2:00	8:00-2:00	KGO	Portland	284.4	610	2000	11:00-3:00	10:30-2:00	9:00-3:00	9:00-3:00	9:00-3:00	9:00-3:00	9:00-3:00	9:00-3:00	
KHJ	405.2	740	500	8:30-12:00	9:00-12:00	Silent	10:00-1:00	10:00-1:00	10:00-1:00	10:00-1:00	KHJ	Los Angeles	405.2	740	500	11:00-1:00	10:00-1:00	Silent	11:00-2:00	11:00-2:00	11:00-2:00	11:00-2:00	11:00-2:00	11:00-2:00
KIAF	421	709	500	Silent	4:00-5:00	9:00-10:00	Silent	9:00-10:00	Silent	9:00-10:00	KIAF	Seattle	421	709	500	Silent	9:00-1:00	9:00-1:00	9:00-1:00	9:00-1:00	9:00-1:00	9:00-1:00	9:00-1:00	
KJR	348.6	860	2500	8:00-1:00	9:15-12:45	8:00-12:00	8:00-12:00	8:00-12:00	8:00-12:00	8:00-12:00	KJR	Seattle	348.6	860	2500	9:00-1:00	9:00-2:00	9:00-1:00	9:00-1:00	9:00-1:00	9:00-1:00	9:00-1:00	9:00-1:00	
KLDS	270.1	1110	1500	Silent	9:15-10:15	Silent	8:00-9:00	8:00-9:00	8:00-9:00	8:00-9:00	KLDS	Seattle	270.1	1110	1500	Silent	10:15-11:15	Silent	9:00-10:00	Silent	Silent	9:00-10:00	Silent	
KLX	508.2	990	500	6:00-9:00	Silent	9:00-12:00	Silent	8:30-12:00	Silent	9:00-12:30	KLX	Oakland	508.2	990	500	7:00-10:00	Silent	10:00-1:00	Silent	9:30-1:00	9:00-1:00	9:00-1:00	9:00-1:00	
KMA	504.5	760	1000	6:00-9:00	Silent	9:00-12:00	Silent	6:00-9:00	6:00-9:00	6:00-9:00	KMA	Shenandoah	504.5	760	1000	7:00-10:00	Silent	7:00-10:00	Silent	9:00-10:00	9:00-10:00	9:00-10:00	9:00-10:00	
KMMJ	229	1310	500	8:00-9:00	8:45-9:45	8:00-9:00	8:00-9:00	8:00-9:00	8:00-9:00	8:00-9:00	KMMJ	Hay Center	229	1310	500	10:00-3:00	7:30-1:00	10:00-2:00	10:00-2:00	10:00-2:00	10:00-2:00	10:00-2:00	10:00-2:00	
KNN	336.9	890	500	9:00-2:00	6:30-12:00	9:00-1:00	9:00-1:00	9:00-2:00	9:00-2:00	9:00-2:00	KNN	Clayton	336.9	890	500	Silent	8:30-12:00	9:30-12:00	9:30-12:00	9:30-12:00	9:30-12:00	9:30-12:00	9:30-12:00	
KOA	325.9	920	5000	Silent	7:30-8:45	8:30-11:00	8:30-11:00	8:30-11:00	8:30-11:00	8:30-11:00	KOA	Dayton	325.9	920	5000	Silent	8:30-12:00	9:00-1:00	9:00-1:00	9:00-1:00	9:00-1:00	9:00-1:00	9:00-1:00	
KOIL	277.6	1060	500	Silent	6:00-12:00	6:00-12:00	6:00-12:00	6:00-12:00	6:00-12:00	6:00-12:00	KOIL	Council Bluffs	277.6	1060	500	Silent	10:45-12:15	11:00-1:00	11:00-1:00	11:00-1:00	11:00-1:00	11:00-1:00	11:00-1:00	
KOIN	319	940	1000	9:15-10:00	8:00-12:00	8:00-12:00	8:00-12:00	8:00-12:00	8:00-12:00	8:00-12:00	KOIN	Portland	319	940	1000	10:15-11:00	9:00-1:00	9:00-2:30	9:00-2:30	9:00-2:30	9:00-2:30	9:00-2:30	9:00-2:30	
KOMO	305.9	980	1000	8:00-2:30	9:00-12:00	8:00-2:30	8:00-2:30	8:00-2:30	8:00-2:30	8:00-2:30	KOMO	Seattle	305.9	980	1000	9:00-3:30	10:00-1:00	9:00-3:30	9:00-3:30	9:00-3:30	9:00-3:30	9:00-3:30	9:00-3:30	
KPO	422.3	710	1000	8:00-2:00	8:00-12:00	8:00-2:00	8:00-1:00	8:00-1:00	8:00-1:00	8:00-1:00	KPO	San Fran.	422.3	710	1000	9:00-3:00	9:00-1:00	9:00-3:00	9:00-2:00	9:00-2:00	9:00-2:00	9:00-2:00	9:00-2:00	
KPRC	293.9	1020	500	7:30-12:00	7:50-10:30	7:30-12:00	7:30-9:30	7:30-9:30	7:30-9:30	7:30-9:30	KPRC	Houston	293.9	1020	500	8:30-1:00	8:50-11:30	8:30-1:00	8:30-10:30	8:30-10:30	8:30-10:30	8:30-10:30	8:30-10:30	
KPSN	315.6	950	1000	10:00-11:00	8:00-9:00	10:00-11:15	10:00-11:15	10:00-11:15	10:00-11:15	10:00-11:15	KPSN	Pasadena	315.6	950	1000	11:00-12:00	9:00-10:00	11:00-12:15	11:00-12:15	11:00-12:15	11:00-12:15	11:00-12:15		
KPSB	267.7	1120	1000	9:00-10:00	8:00-9:00	6:30-12:00	6:30-12:00	6:30-12:00	6:30-12:00	6:30-12:00	KPSB	St. Louis	267.7	1120	1000	10:00-11:00	9:00-10:00	1						

STATE AND CITY INDEX

City	Call	Meters	Kc.	Watts
Alabama				
Auburn	WAPI	325.9	920	1,000
Birmingham	WBRC	243.8	1,230	250
Gadsden	WJBY	218.8	1,370	10
Montgomery	WBZ	230.6	1,300	15
Arizona				
Flagstaff	KFXV	205.4	1,400	25
Phoenix	KFAD	272.6	1,100	500
Prescott	KGJ	243.8	1,230	125
Tucson	KGAR	234.2	1,280	100
Arkansas				
Blytheville	KLCN	285.5	1,050	50
Fayetteville	KUOA	296.3	1,010	500
Hot Springs	KTHS	384.4	780	1,000
California				
Avalon	KFWO	299.8	1,000	250
Berkeley	KRE	256.3	1,170	100
Burbank	KELV	228.9	1,310	250
El Centro	KGEN	225.4	1,330	15
Fresno	KFJ	365.6	820	50
Holy City	KFOU	232.4	1,290	100
Hollywood	KFOZ	232.4	1,290	100
Inglewood	KMIC	223.7	1,340	250
La Crescenta	KGFH	223.7	1,340	250
Long Beach	KFON	241.8	1,240	500
Los Angeles	KGEF	215.7	1,390	100
Los Angeles	KFI	468.5	640	5,000
Los Angeles	KFFR	232.4	1,290	250
Los Angeles	KFSG	275.1	1,090	500
Los Angeles	KFWB	361.2	830	500
Los Angeles	KGEF	263	1,140	500
Los Angeles	KGJF	208.2	1,440	100
Los Angeles	KHJ	405.2	740	500
Los Angeles	KMYR	526	570	500
Los Angeles	KNX	336.9	890	500
Los Angeles	KPLA	252	1,190	500
Los Angeles	KRLO	215.7	1,390	250
Los Angeles	KTBI	238.3	1,040	500
Los Angeles	KGEU	227.1	1,320	50
Los Angeles	KJUS	256.3	1,170	50
Los Angeles	KFWM	415.3	1,270	500
Los Angeles	KLS	384.4	780	5,000
Los Angeles	KLO	245.8	1,220	250
Los Angeles	KLX	508.2	590	500
Los Angeles	KTAB	280.2	1,070	500
Los Angeles	KZM	245.8	1,220	100
Los Angeles	KZYF	238	1,260	25
Los Angeles	KPPC	223.9	1,310	50
Los Angeles	KPSN	315.6	850	1,000
Los Angeles	KFBK	535.4	560	100
Los Angeles	KFWD	222.1	1,350	100
Los Angeles	KFBC	247.8	1,210	100
Los Angeles	KFSD	440.9	680	500
Los Angeles	KFOJ	481.3	500	1,000
Los Angeles	KFWI	287.7	1,120	500
Los Angeles	KGTT	206.8	1,450	50
Los Angeles	KJBS	220.4	1,360	50
Los Angeles	KYO	422.3	710	1,000
Los Angeles	KYA	309.1	970	500
Los Angeles	KQW	296.9	1,010	500
Los Angeles	KSA	352.7	850	50
Los Angeles	KFCR	215.1	1,420	50
Los Angeles	KSMR	272.6	1,100	100
Los Angeles	KNRC	374.8	800	500
Los Angeles	KGDM	217.3	1,380	10
Los Angeles	KWG	344.6	870	50
Los Angeles	KFVD	208.2	1,440	250
Los Angeles	KGFM	211.1	1,420	15
Colorado				
Denver	KFUM	236.1	1,270	100
Denver	KFEL	247.8	1,210	250
Denver	KFUP	227.1	1,320	100
Denver	KFXF	282.8	1,090	500
Denver	KGEY	201.2	1,490	15
Denver	KLZ	267.7	1,120	250
Denver	KOA	375.9	920	5,000
Denver	KOW	425.9	630	250
Denver	KFXJ	215.7	1,390	15
Denver	KGEW	218.8	1,370	10
Denver	KFCR	215.1	1,420	200
Denver	KFH	254.1	1,380	100
Denver	KGDP	223.7	1,340	10
Denver	KFBS	238	1,260	15
Denver	KGFL	222.1	1,350	50
Denver	KGKE	263	1,140	10
Connecticut				
Danbury	WCWS	214.2	1,400	100
Hartford	WTIC	535.4	560	500
Mansfield	WCAC	275.1	1,090	500
New Haven	WDRS	282.2	1,060	500
Sport Hill	WICC	214.2	1,400	500
Delaware				
Wilmington	WDEL	265.3	1,130	100
District of Columbia				
Washington	WMAL	302.8	990	250
Washington	WRC	468.5	640	500
Washington	WRHF	319	940	150
Florida				
Gainesville	WBHN	296.9	1,010	5,000
Jacksonville	WFLA	365.6	820	500
Jacksonville	WJAX	336.9	890	1,000
Lakeland	WMLB	228.9	1,310	50
Miami	WQAM	232.4	1,290	750
Miami Beach	WIOD	245.8	1,210	1,000
Orlando	WMBF	384.4	780	500
Orlando	WDBO	288.3	1,040	500
Pensacola	WCOA	249.9	1,200	500
Tampa	WDAE	267.7	1,120	500
Tampa	WJBB	344.6	870	250
Tampa	WMBR	252	1,190	100
Georgia				
Atlanta	WGST	270.1	1,110	500
Atlanta	WSB	475.9	630	1,000
Atlanta	WTIS	227.1	1,320	200
Macon	WVIZ	270.7	1,110	500
Toccoa	WTFI	209.7	1,430	250
Idaho				
Boise	KFAU	285.5	1,050	2,000
Jerome	KFXD	204	1,470	15
Kellogg	KFEY	232.4	1,290	10
Pocatello	KSEI	333.1	900	250
Illinois				
Atwood	WLBQ	202.6	1,480	25
Batavia	WORD	389.4	770	5,000
Belvidere	WLBK	322.4	930	15
Bloomington	WMBY	199.9	1,500	15
Bloomington	WVIZ	270.7	1,110	500
Carthage	WCAZ	340.7	880	15
Chicago	KFKX	526	570	2,500
Chicago	WAAF	389.4	770	500
Chicago	WBBM	389.4	770	1,000
Chicago	WBBZ	204	1,470	100
Chicago	WBCN	268.3	1,040	500
Chicago	WCFL	483.6	620	1,500
Chicago	WCRW	223.7	1,340	500
Chicago	WEBH	365.6	820	2,000
Chicago	WEDC	241.8	1,240	500
Chicago	WENR	288.3	1,040	500
Chicago	WFKB	223.7	1,340	500
Chicago	WGES	241.8	1,240	500
Chicago	WGN	305.9	980	500
Chicago	WHBL	204	1,470	100
Chicago	WHBM	201.2	1,490	100
Chicago	WHFC	215.7	1,390	200
Chicago	WHT	416.4	720	5,000
Chicago	WIBO	216.4	1,400	100
Chicago	WIBW	201.2	1,490	100
Chicago	WIBW	204	1,470	100
Chicago	WKGB	201.2	1,490	100
Chicago	WJAZ	263	1,140	500
Chicago	WBT	389.4	770	500
Chicago	WCB	22.4	930	50
Chicago	WLBW	204	1,470	100
Chicago	WLS	344.6	870	5,000
Chicago	WLTS	483.6	620	100
Chicago	WMAQ	447.5	670	1,000
Chicago	WMBR	252	1,190	500
Chicago	WMBZ	263	1,140	500
Chicago	WFCB	223.7	1,340	500
Chicago	WJQ	447.5	670	500
Chicago	WSAX	204	1,470	100
Chicago	WSBC	232.4	1,290	500
Chicago	WTAS	288.3	1,040	1,500
Chicago	WTAE	227.1	1,320	500

City	Call	Meters	Kc.	Watts
Illinois (Continued)				
Chi. Heights	WJWB	308.2	1,440	100
Crete	WLS	244.6	870	5,000
Decatur	WBAB	267.7	1,120	100
Deerfield	WJBL	212.6	1,410	250
East Wenona	WLB	416.4	720	5,000
Egin	WGN	305.9	980	500
Evansville	WLIB	305.9	980	1,500
Forest Park	WEHS	215.7	1,390	100
Galesburg	WFBZ	208.2	1,440	200
Galesburg	WFBZ	247.8	1,210	50
Galesburg	WFBZ	217.3	1,380	100
Galesburg	WFBZ	217.3	1,380	100
Galesburg	WRAM	247.8	1,210	50
Harrisburg	WBEQ	223.7	1,340	15
Homewood	WOK	252	1,190	5,000
Joliet	WCLS	215.7	1,390	150
Joliet	WCLS	322.4	930	150
Joliet	WCLS	215.7	1,390	150
La Salle	WJBB	227.1	1,320	100
Maize	WJJD	365.6	820	1,000
Mt. Prospect	WJAZ	263	1,140	5,000
Peoria	WMBD	205.4	1,460	250
Quincy	WTAD	236.1	1,270	250
Rock Island	WLCB	229.7	1,350	100
Springfield	WCBS	209.7	1,400	250
Streator	WTAX	322.4	930	50
Tuscola	WDZ	277.6	1,080	100
Urbana	WRM	272.6	1,100	500
Waukegan	WPPE	215.7	1,390	500
Zion	WCBD	344.6	870	5,000
Indiana				
Anderson	WHBU	220.4	1,360	15
Brookville	WKBY	217.3	1,380	100
Crown Point	WLBT	322.4	930	50
Culver	WCMA	258.5	1,160	250
Evansville	WGFB	236.1	1,270	250
Fort Wayne	WOW	214.2	1,400	250
Fort Wayne	WOW	229.7	1,310	2,000
Gary	WJKS	232.4	930	500
Indianapolis	WFBM	275.1	1,090	1,000
Indianapolis	WFBM	275.1	1,090	50
Kokomo	WJAK	234.2	1,280	50
Laporte	WRAP	208.2	1,440	100
Muncie	WVBC	209.7	1,430	500
South Bend	WSBT	238	1,210	500
Terre Haute	KGFO	204	1,470	100
Valparaiso	WRPI	208.2	1,440	100
W. Lafayette	WBAA	272.6	1,100	500
Iowa				
Ames	WOI	265.3	1,130	2,500
Atlantic	KICK	475.9	630	100
Boone	KFGQ	209.7	1,430	100
Burlington	WIAS	475.9	630	100
Cedar Rapids	KWCR	352.7	850	250
Cedar Rapids	KWCR	297	1,210	500
Clarinda	KSO	352.7	850	250
Council Bluffs	KOIL	277.6	1,080	2,000
Cresco	KGDJ	202.6	1,480	10
Davenport	WOC	374.8	800	5,000
Decorah	KGCA	247.8	1,210	10
Des Moines	KWLC	247.8	1,210	50
Des Moines	KWLC	535.4	560	5,000
Fort Dodge	KFJB	440.9	680	100
Iowa City	KGFB	223.7	1,340	10
LeMars	WSUI	422.3	710	500
Marshalltown	KWUC	243.7	1,230	1,500
Marshalltown	KWUC	247.8	1,210	100
Muscatine	KPNB	211.1	1,420	100
Muscatine	KPNB	211.1	1,420	3,500
Oskaloosa	KFHL	212.6	1,410	10
Shenandoah	KFNH	461.3	650	2,500
Sioux City	KMA	394.5	760	1,000
Sioux City	KFMR	440.9	680	100
Sioux City	KSCJ	243.8	1,230	500
Kansas				
Concordia	KGCN	208.2	1,440	50
Independence	KFGC	225.4	1,330	50
Lawrence	KFKU	254.1	1,180	500
Lawrence	WREN	254.1	1,180	750
Manhattan	KSAC	333.1	900	500
Manhattan	KFKB	241.8	1,240	1,500
Wichita	KFH	245.8	1,220	500
Kentucky				
Hopkinsville	WFIW	280.2	1,070	500
Louisville	WHAS	461.3	650	500
Louisville	WLAP	267.7	1,120	30
Louisiana				
Cedar Grove	KGGH	212.6	1,410	50
New Orleans	WABZ	212.6	1,410	50
New Orleans	WCBE	227.1	1,320	50
New Orleans	WJBO	263	1,140	100
New Orleans	WJBT	238	1,260	30
New Orleans	WKBT	252	1,190	50
New Orleans	WMSB	322.4	930	500
New Orleans	WVLC	275.1	1,090	100
Shreveport	KFDX	236.1	1,270	250
Shreveport	KGDY	212.6	1,410	250
Shreveport	KRAC	220.4	1,360	50
Shreveport	KSBA	267.7	1,120	1,000
Shreveport	KWKH	394.5	760	1,000
Maine				
Bangor	WABI	389.4	770	100
Foxcroft	WLBZ	208.2	1,440</	

State and City Index Continued

Texas (Continued)			
City	Call	Meters	Kc. Watts
Galveston	...KFLX	270.1	1,110
Greenville	...KFUP	258.5	1,160
Harlingen	...KHM	236.1	1,270
Houston	...KRFV	238.9	1,260
San Angelo	...KGF	224.4	1,360
San Antonio	...KGGI	220.4	1,360
Waco	...WJAD	447.5	670
Utah			
Ogden	...KFUR	225.4	1,330
Salt Lake C.	...KDYL	258.5	1,160
Vermont			
Burlington	...WCAX	254.1	1,180
Springfield	...WNBV	241.8	1,240
Virginia			
Arlington	...NAA	434.5	690
Norfolk	...WBBW	209.7	1,430
Petersburg	...WLBG	214.2	1,400
Richmond	...WBBL	247.8	1,210
Roanoke	...WDBJ	230.6	1,300
Va. Beach	...WSEA	263	1,140
Washington			
Aberdeen	...KKRO	227.1	1,320
Everett	...KFB	223.7	1,340
Lacey	...KGY	243.8	1,230
Pullman	...KWSC	394.5	760
Seattle	...KFOA	447.5	670
W. De Pere	...WHBY	249.9	1,200

Washington (Continued)			
City	Call	Meters	Kc. Watts
Seattle (Contd.)	...KJR	348.6	860
Spokane	...KFIO	245.8	1,220
Tacoma	...KVI	234.2	1,280
Walla Walla	...KOWW	299.9	1,000
West Virginia			
Charleston	...WOB	267.7	1,120
Huntington	...WSA	241.8	1,240
Wheeling	...WVVA	388.4	770
Wisconsin			
Beloit	...WEBW	258.5	1,160
Camp Lake	...WLO	227.1	1,320
Eau Claire	...WTAQ	254.1	1,180
Fond du Lac	...KFIZ	267.7	1,120
Kenosha	...WKDS	322.4	930
Madison	...WHA	319	940
Manitowoc	...WOMT	222.1	1,350
Milwaukee	...WGWB	218.8	1,370
Omro	...WJBR	227.1	1,320
Poynette	...WIBU	217.3	1,380
Racine	...WRRS	322.4	930
Sisihit	...WBAR	270.1	1,110
Stevens Point	...WLBI	319	940
Superior	...WZBC	241.8	1,240
W. De Pere	...WHBY	249.9	1,200
Wyoming			
Laramie	...KFBU	428.3	700

Alaska			
City	Call	Meters	Kc. Watts
Anchorage	...KFQD	344.6	870
Juneau	...KFIU	225.4	1,330
Ketchikan	...KGBU	228.9	1,310
Hawaii			
Honolulu	...KGU	270.1	1,110
Manila	...KZIB	249.9	1,200
San Juan	...WKAQ	340.7	880
Philippines			
Bowmanville	...CKCW	312.3	960
Brantford	...CFGC	296.9	1,010
Burketon Jct.	...CKCW	329.5	910
Calgary	...CFAC	434.5	690
Charlottet'n	...CFY	312.3	960
Cobalt	...CKMC	247.8	1,210
Edmonton	...CHMA	516.9	580
Kingston	...CFMC	267.7	1,120
London	...CJGC	329.5	910
Midland	...CKPR	267.7	1,120
Mission City	...CJCU	247.8	1,210
Moncton	...CFCA	322.4	930
Montreal	...CHY	410.7	730
Porto Rico			
Canada			
Victoria	...CFCT	329.5	910
Winnipeg	...CKY	384.4	780
Yorkton	...CJGX	475.9	630

Canada (Continued)			
City	Call	Meters	Kc. Watts
Moose Jaw	...CJRM	296.9	1,010
Burnaby	...CFY	410.7	730
Ottawa	...CKCO	434.5	690
Prescott	...CFCL	296.9	1,010
Preston	...CKPC	247.8	1,210
Quebec	...CHRC	340.7	880
Red Deer	...CKLC	356.9	840
Regina	...CHWC	312.3	960
Saskatoon	...CFQC	329.5	910
Scarboro	...CJYC	291.1	1,030
Sea Island	...CJOR	291.1	1,030
St. Hyacinthe	...CKSH	312.3	960
Summerside	...CHCS	267.7	1,120
Toronto	...CFC	356.9	840
Unity	...CHSC	267.7	1,120
Vancouver	...CFQ	410.7	730
Victoria	...CFCT	329.5	910
Winnipeg	...CKY	384.4	780
Yorkton	...CJGX	475.9	630

Canada (Continued from page 45)

CKWX	Vancouver, B. C. 410.7m-730kc. 10 watts. A. Holstead & Wm. Hanlon.
CKWX	Vancouver, B. C. 410.7m-730kc. 100 watts. West-er Electric.
CKY	Winnipeg, Man., Can. 384.4m-780kc. 500 watts. Manitoba Tel. System. Announcer, F. E. Rutland. Slogan, "Manitoba's Own Station." Daily ex Sun, 10:50-11 am, 12-1:45 pm, 3-4:30, 8:30, 9, Wed, Sat, 9-11 pm, CNRW. Central.
CNRA	Moncton, N. B., Can. 322.4m-930kc. 500 watts. Canadian National Railways. Announcer, W. V. George. Slogan, "Voice of the Maritimes." Daily ex Sun, 2-3:30 pm, Tues, 7:30 pm, Fri, 9 pm. Atlantic. Started Nov. 8, 1924.
CNRC	Calgary, Alta., Can. 434.5m-690kc. 500 watts. Canadian National Railways. Mon, 9:30 pm, Thurs, 7 pm, bedtime story; 9-11. Mountain.
CNRE	Edmonton, Alta., Can. 516.9m-580kc. 500 watts. Canadian National Railways. Wed, 11-12:30 am, Sat, 10-12 mid. Mountain.
CNRM	Montreal, Que., Can. 410.7m-730kc. 1,000-1,650 watts. Canadian National Railways. Announcer, J. S. McArthur. Thurs, 8:45 pm. Eastern daylight.
CNRO	Ottawa, Can. 434.5m-690kc. 500 watts. Canadian National Railways. Announcer, A. W. Ryan. Mon, 8-8:45 pm, 11-12 mid. Thurs, 7:30-11 pm. Eastern. On air Feb. 27, 1924.
CNRQ	Quebec City, Can. 340.7m-880kc. C. N. R.
CNRR	Regina, Sask., Can. 312.3m-960kc. 500 watts. Canadian National Railways. Tues, 8-10 pm. Mountain.
CNRS	Saskatoon, Sask., Can. 329.5m-910kc. 500 watts. Canadian National Railways. Daily, 2:30-3:30 pm. Mountain.
CNRT	Toronto, Ont., Can. 356.9m-840kc. 500 watts. Canadian National Railways. Announcer, E. W. Jackson. Fri, 9-11 pm. Eastern. First broadcast May 16, 1924.
CNRV	Vancouver, Can. 291.1m-1030kc. 500 watts. Canadian National Railways. Announcer, G. A. Wright.
CNRW	Winnipeg, Man., Can. 384.4m-780kc. 500 watts. Canadian National Railways. Announcer, R. H. Roberts. Mon, Tues, 6:30 pm, Wed, 10 pm, Thurs, Fri, 6:30 pm. Central.
Cuba	
2MG	Havana, Cuba. 284m-1055kc. 20 watts. Manuel Y. Guillermo Salas Music Store. Announcer, Roger Morales. Daily 3-4 pm, music. One day each week, 8-11 pm. Eastern.
2MK	Havana, Cuba. 85m-349kc. 100 watts. R. V. Waters.
2MU	Havana, Cuba. 265m-1330kc. 100 watts. Ulpiano Muniz.
2OK	Havana, Cuba. 360m-833kc. 100 watts. Mario Garcia Velez.
2OL	Havana, Cuba. 257m-1170kc. 100 watts. Oscar Collado.
2RK	Havana, Cuba. 315m-950kc. 100 watts. Raoul Karman. Casa De La Porte.
2TW	Havana, Cuba. 270m-1110kc. 20 watts. Roberto E. Ramirez.
2UF	Havana, Cuba. 355m-844kc. 20 watts. Roberto E. Ramirez.
2XA	Havana, Cuba. 230m-1300kc. Lecuona Music Co.
2XX	Havana, Cuba. 225m-1333kc. 5 watts. Antonio A. Ginard.
5DW	Matanzas, Cuba. 270m-1110kc. 100 watts. Ramon Sarría Calderon.
5EV	Colon, Cuba. 360m-833kc. 5 watts. Leopoldo V. Figueroa. Sun, 9-11 pm. Eastern.
6BY	Cienfuegos, Cuba. 260m-1153kc. 200 watts. Jose Ganduxa.
6EV	Caibarien, Cuba. 250m-1200kc. 50 watts. Maria Josefa Alvarez. Daily, 10:30 pm.
6HS	S. La Grande, Cuba. 200m-1500kc. 10 watts. Santiago Ventura.
6KC	Cienfuegos, Cuba. 240m-1250kc. 10 watts. Carlos Hernandez.
6KP	Sancti Spiritus, Cuba. 195m-1540kc. 20 watts. Antonio Galguera.
6KW	Tuinucu, Cuba. 340m-880kc. 100 watts. Frank H. Jones. Slogan, "If You Hear the Koo of the Cuckoo You Are in Tune With Tuinucu." Daily 11:30-12:15 am. Eastern.
6LO	Caibarien, Cuba. 325m-920kc. 250 watts. Manuel A. Alvarez.
6RG	Santa Clara, Cuba. 200m-1500kc. 20 watts. Rafael Garcia Perez.
6XJ	Tuinucu, Cuba. 278m-1080kc. 100 watts. Frank H. Jones.
6YR	Camaguey, Cuba. 200m-1500kc. 20 watts. Diego Iborra.
7AZ	Camaguey, Cuba. 225m-1333kc. 10 watts. Pedro Noguera.
7BY	Camaguey, Cuba. 235m-1277kc. 20 watts. Eduardo V. Figueroa.
7EV	Camaguey, Cuba. 190m-1580kc. 5 watts. Gonzalo Toraya.
7FU	C. Avila, Cuba. 200m-999.4kc. 5 watts. Feliciano Isaac.
7GT	Camaguey, Cuba. 195m-1540kc. Armando Vaquer.
7HS	C. de Avila, Cuba. 192m-1560kc. 10 watts. Porfirio de la Cruz.

7IR	C. de Avila, Cuba. 193m-1550kc. Armando Ben-guria.
7LO	Camaguey, Cuba. 230m-1300kc. 20 watts. Miguel Lopez Martinez.
7JQ	Florida, Cuba. 42m-7130kc. Leonard B. Fox.
7KP	Camaguey, Cuba. 43m-6970kc. 50 watts. Melchor Aguero.
7MN	Camaguey, Cuba. 273m-1100kc. 100 watts. Mel-chor Aguero.
7NM	Nuevitas, Cuba. 264m-1136kc. 20 watts. Domingo Gaymard.
7SR	Camaguey, Cuba. 350m-860kc. 500 watts. Salvador C. Rionda. Slogan, "Cuba, the Land of Sunshine, Sugar and Tobacco." Mon, Tues, Thurs, 8:30 pm. Eastern.
8BY	Santiago, Cuba. 250m-1200kc. 100 watts. Alberto Ravelo.
Mexico	
CYA	Mexico City, Mex. 265m-1130kc. 500 watts. Mon, Fri, 6-4:58 pm. Sun, 4-6 pm. Partido Liberal Avanzado. Mexican.
CYB	Mexico City, Mex. 270m-1110kc. 500 watts. El Buen Tono. Tues, Thurs, Sat, 7:30-9 pm, concert. Mexican.
CYF	Oaxaca, Oax., Mex. 270m-1110kc. Federico Zor-rilla. "The Voice from South of Mexico." Tues, Thurs, 7-8 pm. Sun, 8:30-10 pm. Mexican.
CYG	Mexico City, Mex. 300m-1000kc. 1000 watts. Secretaria de Guerra y Marina.
CYH	Monterey, Mexico. 311m-964kc. 1000 watts. Tar-nava & Cia. Slogan, "The Industrial Center of the Mexican Republic." Daily ex Sun, 7:55-8-10 pm, Wed, Fri, 8:30-10 pm. Sun, 8-10 pm. Mountain.
CYJ	Mexico City, Mex. 410m-730kc. 1000 watts. Gen-eral Electric Co. Daily ex Sun, 8 pm. Mountain.
CYL	Mexico City, Mex. 480m-625kc. 500 watts. La Casa del Radio. Announcer, George Marron. Slog-an, "The Land of Eternal Summer." Daily ex Sun, 1:30-2 pm, weather, financial reports, music, Tues, Fri, 8-9:30 pm. Sun, 8-9:30 pm, church. Mexican.
CYR	Mazatlan, Sin., Mex. Rosseter Y Cia.
CYX	Mexico City, Mex. 333m-900kc. 500 watts. Ex-celsior & Revista de Revistas. Announcer, Rafael Hernandez de Dominguez. Slogan, "Land of the Aztecs." Mon, 8-9:30 pm. Mexican.
CYZ	Mexico City, Mex. 400m-750kc. Liga Central Mexicana de Radio. Mexican.
CZA	Mexico City, Mex. 70-500-1070 meters. Aviation Dept., War Ministry. Announcer, Ricardo S. Bravo. Daily, 12:30-1 pm, time, weather, news; 6:30-7:30, time, markets, music. Mexican.

A Radiant Hearth

CHICAGO. — Many odd designs have been received to contain the parlor Radio receiver, but the most unique is a fire-place, for which a patent has just been granted a Chicago inventor.

BIG NEW CATALOG FOR RADIO BUILDERS

FREE My big 1928 Radio Catalog, Call Book and Trouble Finder. 132 pages about Radio. Check full of newest eir-cuits—kits, transmitter parts, short wave outfits, eliminators and speakers. Thousands of bargains at lowest wholesale prices. A regular Radio Encyclopedia—Free. Write today.

American Auto & Radio Mfg. Co.
HARRY SCHWARTZBERG, PRES.
Dept. 115, American Radio Bldg., Kansas City, Mo.

LATEST RADIO CIRCUITS

Yale GROUND HOG

DOUBLES POWER AND DISTANCE

Marvelous newly-invented ground gives 100% improved reception. Doubles power and distance. Stops leakage. Reduces static. Stops jangling even in midsummer. Amazing results, users say. Satisfaction guaranteed.

Proven absolutely essential to clear, powerful distance reception. Draws and holds moisture indefinitely. Highly sensitive to radio energy. SEND NO MONEY—To introduce, we offer to those who act at once, regular \$5.00 size for only \$2.95. Send name today and pay \$2.95 plus postage on delivery. Or send only \$2.95 with order and save postage.

FREE—Full description of Ground Hog on Request. Send today.

DEALERS, Write for Attractive Proposition and Prices

Yale Specialty Supply Co.
8838 Main St., Kansas City, Mo.

A HOMEY HOTEL IN THE HEART OF NEW YORK

THE New Flanders

47th to 48th STREET EAST OF BROADWAY

One of the finest Hotels in TIMES SQUARE

Single Rooms with Running Water, \$2.00
Double Rooms with Running Water, \$3.00
Single Rooms with Bath \$2.50
Double Rooms with Bath . . . \$3.50

Special Weekly Rates
F. W. BIZEL, Resident Manager

Official Wave Lengths Table

Wave length	Frequency (kilocycles)	Power (watts)	Call signal	Location	Wave length	Frequency (kilocycles)	Power (watts)	Call signal	Location	Wave length	Frequency (kilocycles)	Power (watts)	Call signal	Location	Wave length	Frequency (kilocycles)	Power (watts)	Call signal	Location							
199.9	1,500	15	KCFN	Aneta, N. D.	215.7	1,390	10	KFDZ	Mpls., Minn.	232.4	1,290	10	KFEY	Kellogg, Idaho	256.3	1,170	750	WREN	L'vence, Kan.	293.9	1,020	250	KGCH	Wayne, Neb.		
		50	KUJ	Seattle, Wash.			15	KFJX	Edgewood, Colo.			250	KFPR	Los A., Calif.			1,000	WRVA	Richmond, Va.			500	KPRC	Houston, Tex.		
		15	KWBS	Portland, Ore.			100	KGCB	Oklahoma, Okla.			500	KFQZ	H'lyw'd, Calif.			500	WTAQ	E. Cl're, Wis.			1,000	WGL	Secaucus, N. Y.		
		15	WBZ	L'd'n, Mich.			100	KGER	Long B., Cal.			100	KUJ	Austin, Tex.			250						500	WLBW	Oil City, Pa.	
		15	WMBY	B'l'm'g't'n, Ill.			250	KGFG	Oklahoma, Okla.			500	WHBQ	M'phis, Tenn.			3,500						1,000	WODA	Faterson, N.J.	
		15	WNLB	B'l'm'g't'n, Ill.			5	KRLO	Los Ang., Cal.			30	WLBH	F'rmdale, N.Y.			1,000						1,000	WTMJ	Milw., Wis.	
		250	WRAH	Prv'dce, R. I.			50	WACS	Lex'ton, Mass.			500	WMBJ	Monessen, Pa.			250									
201.2	1,400	50	KGEH	Eugene, Ore.	217.3	1,380	100	WCLS	Kingst'n, N.Y.	234.2	1,280	1,000	KFVE	St. Louis, Mo.	258.5	1,160	1,000	WCSO	Springfield, O.	296.9	1,010	500	KOW	S. Jose, Calif.		
		15	KGEY	Denver, Colo.			100	WDBZ	Evans'ton, Ill.			15	KGAR	Tucson, Ariz.			250	WASH	G. Rap., Mich.			500	KUOA	F'ettev'le, Ark.		
		50	WALK	Will. C., Pa.			200	WEHS	Evans'ton, Ill.			100	KVJ	Tacoma, Wash.			500	WBWR	R'ville, N. Y.			100	WADC	Akron, O.		
		100	WATT	Boston, Mass.			150	WHFC	Chicago, Ill.			100	WFB	Knox, Tenn.			500	WCSB	Springfield, O.			100	WBES	Tak. Pk., Md.		
		100	WCBR	Prv'dce, R. I.			150	WKBB	Joliet, Ill.			100	WFB	El Paso, Tex.			500	WDBJ	Br'klyn, N. Y.			5,000	WEPS	Clou'er, Mass.		
		100	WCMU	N. Y., N. Y.			250	WOKO	Pkski, N. Y.			250	WGBF	Ev'sville, Ind.			250	WEL	St. Louis, Mo.			200	WBNB	G'ness'le, Fla.		
		100	WBHM	Chicago, Ill.			250	WPEP	Waukegan, Ill.			1,000	WHD	C. Rap., Mich.			250	WNL	Omaha, Neb.			1,000	WSMK	Dayton, O.		
		100	WIBM	Chicago, Ill.			500	WQAA	P'k's'rg, Pa.			250	WJAK	Kokomo, Ind.			2,000						5,000	WWNC	Ashev'le, N.C.	
		100	WKBG	Chicago, Ill.	218.8	1,370	10	KGEW	F. Mrgn., Col.	236.1	1,270	250	KFDX	Shr'v'port, La.	260.7	1,150	2,000	KGA	Spokane, Wash.	299.8	1,000	250	KFWO	Avalon, Calif.		
		100	WRMU	N. Y., N. Y.			500	WCGU	Coney Is., N.Y.			500	KFMX	N'field, Minn.			500	WABQ	Phila., Pa.			10	KGFW	Ravenna, Neb.		
202.6	1,480	100	KCBS	Seattle, Wash.			500	WGBW	Milw., Wis.			100	KFM	C. Sp'gs, Colo.			500	WADY	M'phis, Minn.			750	KMOX	St. Louis, Mo.		
		50	KGBY	Columbus, Neb.			100	WKBC	Bm'gton., N.J.			500	KFWM	O'k'f'n, Calif.			100	WDBA	Beloit, Wis.			500	KOWW	WallaWalla, W.		
		100	KGDJ	Cresco, Ia.			500	WKBO	Jsy. C., N. A.			100	KHMC	Harl'gen, Tex.			500	WFL	St. Louis, Mo.			500	WBAK	Harburg, Pa.		
		15	KGDR	San Ant., Tex.			500	WKBN	N. Y., N. Y.			500	WBBW	Norfolk, Va.			500	WFO	W'ville, N. Y.			250	WBAK	Harburg, Pa.		
		15	KGEO	Mpls., Minn.			100	WKBH	La Cr., Wis.			1,000	WCBF	Ev'sville, Ind.			1,000	WRHM	M'phis, Minn.			5,000	WPSC	St. Col'ge, Pa.		
		25	WLBO	Atwood, Ill.			100	WKBK	Bm'gton., N.J.			500	WCAL	N'field, Minn.			2,000									
		15	WNBO	R'ch's't'r, N.Y.			100	WKBK	Bm'gton., N.J.			500	WCBF	Ev'sville, Ind.			500									
		50	WPSW	Phila., Pa.			100	WKBQ	N. Y., N. Y.			1,000	WHAP	N. Y., N. Y.			500									
204	1,470	15	KFXD	Jerome, Idaho	220.4	1,360	15	KCCI	San Ant., Tex.	238	1,260	15	KFBT	Trinidad, Colo.	263	1,140	50	KFPW	Car'ville, Mo.	302.8	990	1,000	KSL	S. L. City, Utah		
		100	KGFO	Tre. Hte., Ind.			50	KGCR	San Ant., Tex.			25	KFYR	B'm'rk, N. D.			10	KGEE	Yuma, Colo.			100	WBSI	Boston, Mass.		
		100	WBBZ	Chicago, Ill.			100	KJBS	San Fran., Cal.			100	WFO	W'ville, N. Y.			500	WJAZ	Mt. Prosp., Ill.			750	WGR	Buffalo, N. Y.		
		100	WHBL	Chicago, Ill.			50	KKRC	Shreve'pt, La.			500	WBBW	Norfolk, Va.			150	WJBI	Red Bank, N.J.			250	WMAL	Wash'ton, D.C.		
		150	WIBS	Eliz., N. J.			50	KKX	Portland, Ore.			500	WCBF	Ev'sville, Ind.			100	WBNH	N. B., Mass.			250	WNAK	Yankton, S.D.		
		100	WBW	Chicago, Ill.			100	WBBU	Anders'n, Ind.			1,000	WHMC	Harl'gen, Tex.			500	WOB	C. Rap., Mich.			5,000	WOAI	San Ant., Tex.		
		250	WKEN	Kenmore, N.Y.			15	WBBK	Ypsint., Mich.			250	WSBT	So. Bend, Ind.			2,000									
		50	WLBX	L. I., N. Y.			15	WBBH	La Cr., Wis.			250	WBT	So. Bend, Ind.			500									
		100	WMB	Newport, R.I.			100	WMBQ	Auburn, N. Y.			250	WBT	So. Bend, Ind.			500									
		100	WMBH	Joplin, Mo.			100	WMBQ	Auburn, N. Y.			250	WBT	So. Bend, Ind.			500									
		100	WMBW	Br'klyn, N.Y.			100	WMBQ	Auburn, N. Y.			250	WBT	So. Bend, Ind.			500									
		10	WOB	Ohio (Port.)			100	WMBQ	Auburn, N. Y.			250	WBT	So. Bend, Ind.			500									
		100	WSAX	Chicago, Ill.			100	WMBQ	Auburn, N. Y.			250	WBT	So. Bend, Ind.			500									
		50	WTF	Mt. V. H., Va.			100	WMBQ	Auburn, N. Y.			250	WBT	So. Bend, Ind.			500									
		50	WTRC	Br'klyn, N. Y.			15	WMBQ	Auburn, N. Y.			250	WBT	So. Bend, Ind.			500									
205.4	1,460	25	KFX	Flagstaff, Ariz.	222.1	1,350	100	KFWC	S. Bernd., Cal.	239.9	1,250	2,500	KEX	Portland, Ore.	265.3	1,130	15	KKP	Seattle, Wash.	315.6	950	50,000	KDKA	Pitts'bg, Pa.		
		50	KGDE	Barrett, Minn.			50	KGFL	Trinidad, Colo.			250	KFYR	B'm'rk, N. D.			2,000	KTSA	San Ant., Tex.			1,000	KPSN	Pasad'a, Calif.		
		100	KGEO	Grand Ia., Neb.			100	KKWC	Kans., Co. Mo.			100	WBBP	P'k'ey, Wash.			100	WDEL	W'm'g't'n, Del.			1,500	KOIN	Portland, Ore.		
		100	KGEZ	Kalisp'li, Mont.			100	WCB	Belletntne, Pa.			100	WEAM	N. F'id, N. J.			1,000	WHK	Cleveland, O.			500	WEAN	Providence, R.I.		
		25	KGFF	Alva, Okla.			100	WCB	Belletntne, Pa.			100	WBMA	Madison, Wis.			1,000	WNOX	K'ville, Tenn.			1,500	WGHP	Mt. C., Mich.		
		250	WABF	Kingston, Pa.			100	WCB	Belletntne, Pa.			100	WNB	Madison, Wis.			1,000	WOB	C. Rap., Mich.			750	WHA	Madison, Wis.		
		15	WKBL	Peoria, Ill.			100	WCB	Belletntne, Pa.			100	WNB	Madison, Wis.			1,000	WOB	C. Rap., Mich.			1,000	WHB	Stev. Pt., Wis.		
		100	WMB	Chicago, Ill.			100	WCB	Belletntne, Pa.			100	WNB	Madison, Wis.			1,000	WOB	C. Rap., Mich.			150	WRHF	Wash., D. C.		
		100	WRK	Hamilton, O.			100	WCB	Belletntne, Pa.			100	WNB	Madison, Wis.			1,000	WOB	C. Rap., Mich.							
		50	WSVS	Buffalo, N. Y.			100	WCB	Belletntne, Pa.			100	WNB	Madison, Wis.			1,000	WOB	C. Rap., Mich.							
206.8	1,450	100	KGDW	Hmbldt., Neb.	223.7	1,340	50	KFBL	Ev'r't, Wash.	243.8	1,230	125	KFCB	Phoenix, Ariz.	270.1	1,110	100	KFLX	G'veston, Tex.	325.9	920	2,000	KFQB	Ft. Wth., Tex.		
		15	KGDY	Oldham, S. D.			50	KFVR	Ok. City, Ok.			10	KGCX	Vida, Mont.			600	KGU	Honolulu, T. H.			5,000	KO	Denver, Colo.		
		100	KGEE	Fisher, Okla.			50	KGDP	Pueblo, Colo.			150	KGRS	Superior, Wis.			1,500	KLDS	Ind'pnce, Mo.			2,500	WABC	Rchd Hill, N.Y.		
		50	KGIT	San Fr., Calif.			250	KGFL	La Cres., Cal.			500	KGY	Lacey, Wash.			500	KOAC	Corvallis, Ore.			1,000	WABU	Auburn, Ala.		
		100	KLIT	Portland, Ore.			50	KGFK	Halleck, Mich.			500	KSCJ	Sioux City, Ia.			500	KQV	Pittsburgh, Pa.			500	WABQ	Rchd Hill, N.Y.		
		100	WHPP	N. Y., N. Y.			250	KMIC	Inglewd., Cal.			1,500	KWUC	LaMars, Ia.			500	WBAO	Decatur, Ill.			50	KFOA	St. Louis, Mo.		
		50	WLBW	Mansfield, O.			500	WCM	Camden, N. J.			100	WAFD	Detroit, Mich.			100	WBKN	Br'klyn, N. Y.			50	WBJA	Joliet, Ill.		
		100	WMRJ	Jamaica, N.Y.			15	WCRW	Chicago, Ill.			100	WAFD	Detroit, Mich.			100	WBMS	U. City, N. J.			100	WBJ	Chicago, Ill.		
		100	WMBE	Peoria, Ill.			50	WCRW	Chicago, Ill.			100	WAFD	Detroit, Mich.			100	WBMS	U. City, N. J.			15	WBCN	W'ville, N. Y.		
		50	WNB	Chicago, Ill.			500	WCRW	Chicago, Ill.			100	WAFD	Detroit, Mich.			100	WBMS	U. City, N. J.			15	WBCN	W'ville, N. Y.		
		100	WRK																							

Wave length	Frequency (kilocycles)	Power (watts)	Call signal	Location	Wave length	Frequency (kilocycles)	Power (watts)	Call signal	Location	Wave length	Frequency (kilocycles)	Power (watts)	Call signal	Location	Wave length	Frequency (kilocycles)	Power (watts)	Call signal	Location
379.5	790	750	KMMJ C'y Cen., Neb.	500	KWSC Pullm'n, W.h.	428.3	700	500	KFBU Laram., Wyo.	500	590	500	KRLD Dallas, Tex.	508.2	590	500	500	500	KILX Oakland, Cal.
		500	WCAJ Uni. Pl., Neb.	500	WHN N. York, N. Y.			500	WCSH Portland, Me.	500		500	WBRL Tilton, N.H.			500	500	500	WIP Philadelphia, Pa.
		50,000	WGY Schn'dy, N. Y.	500	WPAP C'l's'd, N. J.			5,000	WLW Harrison, O.	500		500	WHAS L'v's'le, Ky.			1,000	500	500	WOO Phila., Pa.
		500	WHAZ Troy, N. Y.																WOW Omaha, Neb.
384.4	780	5,000	KGO Oakland, Calif.	200	KFKA Gre'ty, Colo.	434.5	690	1,000	NAA Radio, Va.	468.5	640	5,000	KFI Los Angeles, Cal.	516.9	580	500	500	500	WCAE Pittsb'gh, Pa.
		1,000	KTHS Hi. Sp'gs, Ark.	1,000	WEAR C'l'v'd, O.							500	WOS Jef. City, Mo.			500	500	500	WMC Memphis, Tenn.
		100	WBSO Ws.Hls., Mass.	3,500	WTAM C'l'v'd, O.	440.9	680	100	KFJY Ft. Dodge, Ia.	475.9	630	100	KICK Atlantic			100	1,000	1,000	WAG Wrcstr., Mass.
		250	WCAO Bltmo, Md.					100	KFMR So. C'y, Ia.			250	KOW Denver, Col.			100	1,000	1,000	WIAS Burlington, Ia.
		100	WCBM Bltmo, Md.	405.2	740	500	740	500	KFSD S. Diego, Cal.	483.6	620	500	KFDM Beaum't, Tex.	526	570	2,500	500	500	KFKX Chicago, Ill.
		500	WMBF Mi. Bch., Fla.	500	WCCO Mn.-S. P.Mi.			500	WIBC Elk's Pk., Pa.			1,500	KUSD Vermillion, S.D.			2,500	500	500	KYV Chicago, Ill.
		100	WSRO Mid'town, O.	500	WFI Phila., Pa.			5,000	WJR-WCX Pnc, Mich.			1,000	WEMC B'r'n S., Mich.			500	500	500	KMTR Los Ang's, Cal.
389.4	770	500	WAAF Chicago, Ill.	413	726	500	726	1,000	KFOA Seat., Wash.	491.5	610	1,000	KGW Portland, Ore.	535.4	560	100	5,000	5,000	WNYC N. Y., N. Y.
		100	WABI Bangor, Me.			500	726	1,000	WEEI Boston, Mass.			5,000	WEAF N. Y., N. Y.			250	5,000	5,000	WCAH Columbus, O.
		1,000	WBBM Chicago, Ill.	416.4	720	5,000	720	1,000	WJAD Waco, Tex.			1,000	WJAZ Chicago, Ill.			5,000	5,000	5,000	WHO Des Moines, Ia.
		500	WBBT Chicago, Ill.			1,000	720	1,000	WMAQ Chicago, Ill.	499.7	600	50	WFUT S. L. City, U.	545.1	550	500	500	500	WTIC Hartford, Conn.
		5,000	WORD Batavia, Ill.			5,000	720	30,000	WQJ Chicago, Ill.			1,500	WBAP Ft. Worth, Tx.			75	750	750	KFDU St. Louis, Mo.
		100	WVVA Wh'l. W. V.			1,000	720	2,000	KFNF Shenand'h, Ia.			75	WBAY Ch'r'ston, S.C.			500	500	500	KSD St. Louis, Mo.
394.5	760	500	KFDY B'ks, S. Dak.	422.3	710	1,000	710	1,000	KPO San Fran., Cal.			500	WBBY Ch'r'ston, S.C.			500	500	500	WMAK Lockport, N.Y.
		1,000	KMA Shenandoah, Ia.			500	710	500	WOR New'k, N. J.			500	WFAA Dallas, Tex.			500	500	500	
		5,000	KOB St. Col., N. M.			500	710	500	WSUI Iowa City, Ia.			1,000							
		1,000	KTW Seattle, Wash.																
		1,000	KWKH Shrevep't, La.																

CLASSIFIED ADVERTISEMENTS

How about that new set you want to buy? What are you going to do with the old one? A Radio Digest classified advertisement will sell it for you. Rates are twenty cents a word for each insertion. Five per cent discount for four insertions, 10 per cent discount for six insertions, 15 per cent discount for twelve insertions. Name and address are counted. Two initials count one word. Cash must accompany order. Minimum of ten words. Objectionable and misleading advertisements not accepted.

Business Opportunities

LAND FREE if planted to bananas. Bananas bear a full crop the second year. \$5.00 monthly will plant five acres, which should pay \$1,500 profit annually. Reliable Companies will cultivate and market your bananas for 1/3. Bananas ripen every day and you get your check every 90 days. For particulars address Jantha Plantation Co., Empire Building, Block 978, Pittsburgh, Pa.

Employment

Agents

RADIO AGENTS—Make Big Money—Easy! Selling Marvelous New Sets and accessories. Buy from factory at lowest prices. Get New Catalog with thousands of nationally advertised bargains. FREE Call Book. Write today. American Auto and Radio Co., Dept. 118, American Radio Bldg., Kansas City, Mo.

WE PAY \$48 a week, furnish auto and expenses to introduce our Soap and Washing Powder. Buss-Beach Company, Dept. A186, Chippewa Falls, Wis.

Male Help

Wanted: First-class Government licensed operator for Radio Broadcasting Station. State experience, references, age, salary. Box 101, RADIO DIGEST.

40% commission selling printed business stationery at knock-out prices. Part or full time. Free outfit V. Process Service, Minneapolis, Minn.

Government Forest Rangers, Meat Inspectors, Patrol Guards, Special Agents, Mail Clerks, Chauffeur-Carriers, needed often. \$125-\$250 month. "How to Qualify" mailed Free. Write, Ozment, 206, St. Louis, Mo.

Earn \$25 weekly, spare time, writing for newspapers, magazines. Experience unnecessary. Details FREE. Press Syndicate, 1269, St. Louis, Mo.

MEN; get Forest Ranger job; \$125-\$200 monthly and home furnished; permanent, hunt, fish, trap. For details, write Norton, 362 McMann Building, Denver, Colo.

Maps

New Radio Maps. We are now able to supply our readers with new radio maps, showing location of stations, list of all stations by call letters. Come folded in cover, but may be used for pasting on cardboard. Size 28x34". Send 25 cents stamps or coin to Shopping Service, Radio Digest, 510 N. Dearborn St., Chicago, Ill.

Miscellaneous

The new and improved Proof of Reception Cards are the most practical and convenient proof of reception of those distant stations. Contains spaces for complete reception record, dial settings, call letters, stamps and signature of announcer. Handy size, 3x5 inches. 150 for \$1 or send 25 cents (stamps or coin) for sample package. Shopping Service, Radio Digest, 510 N. Dearborn St., Chicago, Ill.

Patent Attorneys

PATENTS. Booklet free. Highest references. Best results. WATSON E. COLEMAN, Patent Lawyer, 724 Ninth St., N. W., Washington, D. C.

Radio

Change your phonograph into a loud speaker with the Fultone Unit for only \$2 C. O. D., or postpaid if cash accompanies order. Bronstein's Pharmacy, 4600 Lincoln Ave., Chicago.

AMUSEMENT at home; any boy can attach our special microphone in one minute and listen to any country. It's not attached to your set. Price \$7.00. HOME-SIDE RADIO CO., 233 Scott, San Francisco.

We have an oversupply of the famous Fultone loud speakers which we are disposing of at only \$4.95 C. O. D., or postpaid if cash accompanies the order. Bronstein's Pharmacy, 4600 Lincoln Ave., Chicago.

Free Wholesale Radio Catalog Send today for it
1928 Catalog Dealers, set builders — make this your biggest radio season. Shure's great wholesale catalog insures the best in quality at lowest prices. This wonderful book is jammed full of the newest offerings of Nationally known radio parts, kits, sets, accessories, table and console cabinets, etc. Also contains short wave section showing the finest electrical apparatus for short wave receiving and transmitting. Your request on letterhead brings our book of a thousand bargains, price list and discount sheet. Write for a copy today.
2000 Items **Big Values**
Shure Radio Company
 337 S Madison St. Chicago, Ill.

KNICKERBOCKER 4

The Wonder Set
 2-DIAL KARAS EQUAMATIC
 5-TUBE RECEIVER

THESE two famous receivers, as well as scores of other well known sets, owe no small part of their marvelous performance to the use of Karas Parts. Karas Condensers, Transformers, Filters, Coils and Diodes are the perfected products of a factory which has been building precision electrical apparatus for more than a third of a century. Write today for complete catalog of all Karas Parts, and details of the Knickerbocker 4 and the 2-Dial Karas Equamatic.

KARAS ELECTRIC CO.
 4034-K North Rockwell Street, Chicago



MAN! OH, MAN!

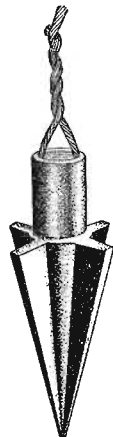

You cannot get faultless reception unless you have good ground connection, and you cannot have efficient ground connection unless your ground WIRE actually makes contact with moist earth. Try a Ross copper ground point and note the amazing difference; it's efficient. If your dealer does not handle, send us \$1.08 plus 17c postage and packing; use it 90 days, if not satisfied return it and get your money back.

REEVES SPECIALTY CO.
 HAMILTON, OHIO

DIRECT FACTORY SALE

Wholesale prices. Tremendous savings. Selling direct to you. Here are some of our many items: 30 Henry Choke, 100 M. A., \$2.19; 10 Henry Choke, 400 M. A., \$5.48. Power Transformers for all kinds of Eliminators and for all types of A. C. Tubes, at Special Low Prices. EVERY ITEM FULLY GUARANTEED. Promptly shipped, upon receipt of order. Send for free illustrated catalog today. Todd Electric Co., Inc. (Manufacturers) 36 West 20th Street, Dept C, New York City.

Stamps

RADIO STATION stamps bought, sold and exchanged. Chas. A. Philius, 510 East 120th St., New York, N. Y.

AT LAST—Control of Radio Reception From Your Easy Chair



Turn set on and off—get station after station—swiftly—surely—DX—without leaving your easy chair.
Thermodyne
 Remote Control Radio Tuning Unit
 No other tuning unit in the world like it. Tune your set from any room of your home. Attached to any single dial receiver with removable dial in a few minutes by removing old dial and attaching adapter plate with Remote Control Unit.
 Mechanical Model... \$18.00
 Electrical Model... 60.00
 West of Rockies, add 10%
 Write today for circular describing radio's newest and most revolutionary development.
ALGONQUIN ELECTRIC COMPANY, Inc.
 Leo Potter, President
 245 Fifth Avenue, New York City

Hotel Eastgate

Ontario at St. Clair
 Chicago
 Telephone Superior 3580

2 Blocks North and 1 Block East of Tribune Tower

Just a "Whisper" from the Loop

Unlimited Parking

Cafe offering unexcelled cuisine at moderate prices

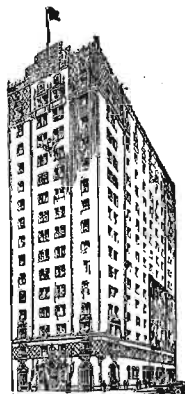

Rates \$2.50 to \$4.00 Per Day — No Higher

Special Rates to Permanent Guests

5 TUBE RADIO ONLY \$19.98
 It's a wonder for power and selectivity. Famous ART circuit. Coast to coast reception! Finely built of selected, tested parts. Thousands now in use. FREE Log and Call Book and New 1928 Catalog with thousands of nationally advertised bargains. Latest in radio at big savings. Write for Free copy. **AMERICAN AUTO & RADIO MFG. CO.** BARRY SCHWARZBAUM, Pres. Dept. 111 American Radio Bldg., Kansas City, Mo.

Set Builders!
 Be first to build the new Magnaformer 9-8 Circuit—Commander-in-Chief of the Air—featured by Radio Authority G. M. Best in Sept. and Oct. Radio. Read his articles. See also Sept. and Oct. Popular Radio and C. R. Call Book. Two years ahead of the field. Outstanding feature is its marvelous Tone-Quality. Women, musicians and experts especially are enthusiastic in their praise of its amazing fidelity of tone. The NEW scientifically designed and precisely matched Magnaformer Intermediate Long Wave R. F. Transformers are the cause. Everyone who hears or tunes a Magnaformer 9-8 decides to own one immediately. Beautiful in appearance. Changes from 9 to 8 or 8 to 9 tubes instantly. Great distance getter—super-selective—a world of volume—quiet operating—easy to tune—easy to build. Any one can do it. All standard parts. NO AFTER-SERVICE. The Ideal set to build for others. Send NOW for free descriptive literature.
RIADIAT LABORATORIES COMPANY
 Dept. 107 Chicago
 19 S. La Salle Street

DOUBLE DISTANCE DOUBLE VOLUME NEW TUBE
 We guarantee this tube to double your range and distance or your money refunded. This tube has proven to be 6 times as sensitive as an ordinary 201A tube. The Prexto tube is setting records for distant reception. Increases selectivity 50%. Tested by Radio World, Radio Digest, and other leading laboratories. Insert tube in detector socket, and set is ready for operation. One year of use guaranteed. Try at our risk, 50,000 users today. You to be the judge. Money refunded if not satisfied. The latest in tubes. Order Today! Price, \$3.00 Postpaid.
 Verified Statements of Users.
 "You are right, the Prexto tube does bring the distant stations closer. I am particularly pleased. Would like to have your agency." George A. Scott, Dealer, Pittsburg
 "I use about half as much current as I did before. Get distant stations from everywhere, even through static on bad nights. Would not take \$10.00 for Prexto tube, if could not get another." D. G. Fidler, Asheville, N. C.
 "Have added station on my log 1500 miles further than before, since using your tube." J. P. Henderson, Detroit.
PREXTO MFG. & SALES CO.
 Dept. 2—Beaumont Texas

World "A" Socket Power Unit
\$13.75
Save 50%
 No better "A" Socket Power Unit can be obtained even at twice this amazingly low price. Combines all the efficiency of plate current with the undoubted convenience of socket power. No bothersome hauling around of batteries to be charged. No hum or noise. Highest quality Westinghouse electrical equipment. Operates on 50 or 60 cycles at 110 volts A. C. Thousands of satisfied users prove the worth of World Power Units. Approved by rigid tests of Radio News and other leading Laboratories. Just name and address; and we will ship day order is received by express C. O. D. subject to examination on arrival. 5% discount for cash in full with order. NOW is the time to do it.
WORLD BATTERY COMPANY
 1219 So. Wabash Ave., Dept. 62, CHICAGO, ILL.
 Station WSBG owned and operated by World Battery Company

At the first crack
of the World's Series
bat....

“You're there with a Crosley!”

The Crosley Radio Corporation:
Can you explain “balancing,” so folks can understand it? We technical people know that Hazeltine's neutrodyne principle is a wonderful thing. If you can make it understandable to laymen you're good.
Yours truly,
Southern Equipment Co.,
San Antonio, Tex.

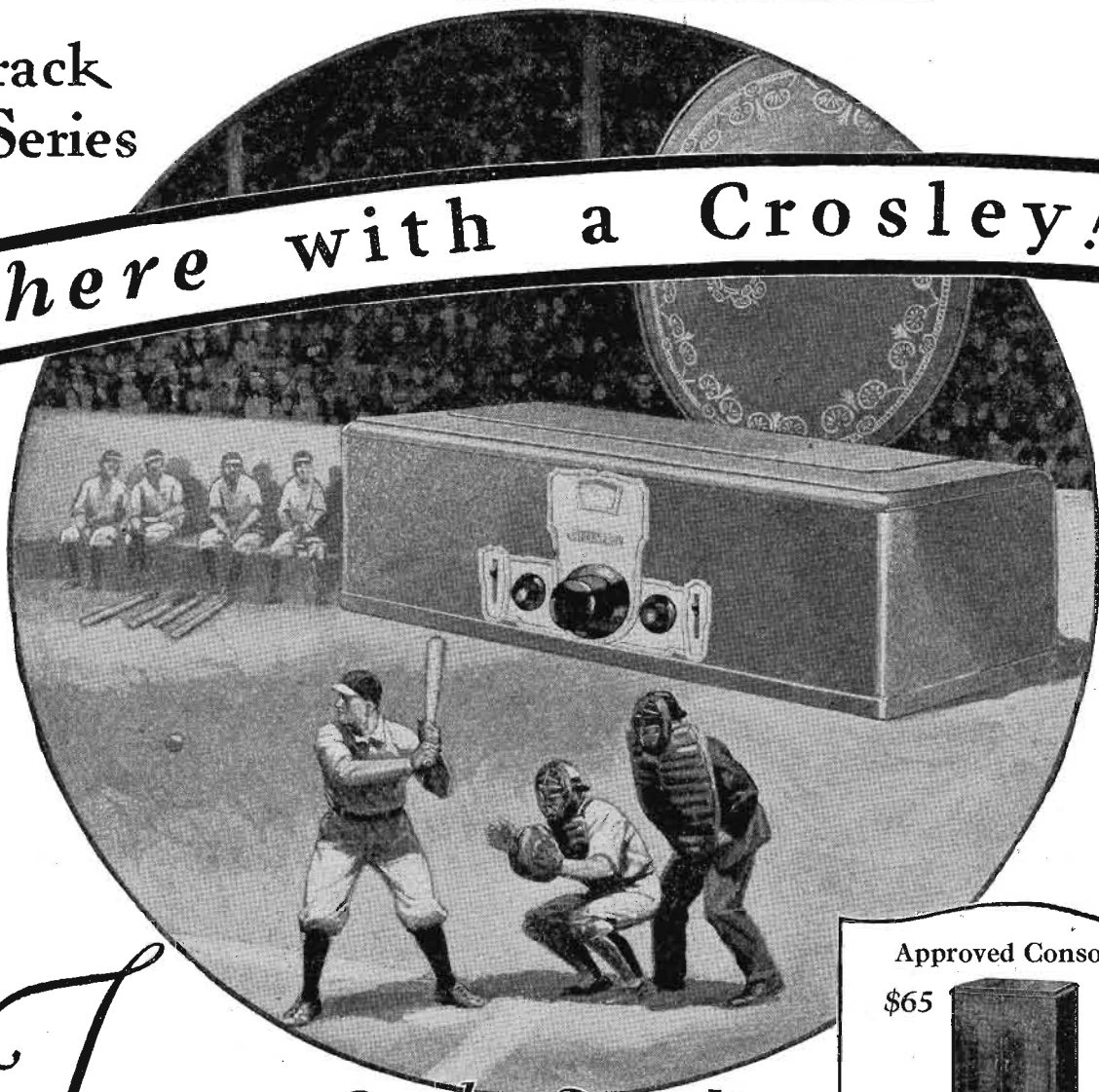

Nature always puts obstacles in our way. When men begin to study a new invention or discovery they find that there are many problems to solve before a successful device can be built. This was the case with the steam engine, the printing press, the automobile, the aeroplane, and every other major invention that you can think of.

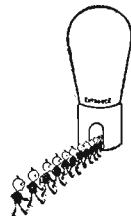

SIGNAL VOLTAGES GOING INTO A MULTIPLYING TUBE

The vacuum tube is, perhaps, one of the most remarkable inventions ever made. We found that we could use it to amplify the radio signals. But when we tried to tune these amplifiers, so that they would help us select the desired signal, we found that the vacuum had a tendency to misbehave.

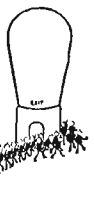

SIGNAL VOLTAGES LEAVING TUBE GREATLY AMPLIFIED BUT SOME RUN AROUND TO ENTRANCE AND CROWD IN WITH THE LITTLE INCOMING SIGNALS

When a tube is used to amplify, the output voltage is much stronger than the input voltage. This is the natural result of the amplification. But there is a path back through the tube through which some of the strong output voltage can get back to the input side of the tube. This voltage is then again amplified and again returns, getting stronger each time, the result being that the tube goes wild. It becomes a miniature broadcasting station on its own hook.



AMPLIFIED SIGNALS RETURNING TO TUBE MIXING IT UP WITH INCOMING SIGNALS

If we can provide a second path from the output circuit to the input circuit, so arranged that the voltage which comes back through this second path is opposed to the voltage that comes back through the tube itself we can prevent the trouble. This is called “balancing” because the second path is adjusted so that it exactly balances the path through the tube.

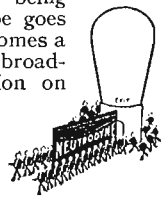

HAZELTINE DIVIDES BOLSHIEVIK VOLTAGES, BALANCING EACH OTHER BY OPPOSING EACH OTHER. THEY CAUSE NO BUMPUS IN THE TUBE AND PROGRAM SIGNALS GO THROUGH AMPLIFIER WITHOUT INTERFERENCE

The Hazeltine method of balancing (or neutralizing) this path through the tube has several unique advantages over all the other methods that have been proposed. This is why Crosley radios use the Hazeltine “neutrodyne” method.

THIS new Crosley Bandbox
6 TUBE RECEIVER *de luxe*
is the national radio hit at \$55.

Its amazing performance is the result of its remarkable construction—the introduction of features found in the most expensive of radios and possible at \$55 only through mass production methods, plus the licensing of Crosley for use of the patents, research resources and discoveries of The Radio Corporation of America, The General Electric Co., The Westinghouse Co., The American Telephone & Telegraph Co., and The Hazeltine and Latour Corporations.

Check any radio at any price against these Crosley features—standards of comparison that indicate the Bandbox's superiority.

- 1—Completely shielded coils, condensers and wiring.
- 2—Acuminators for sharpest tuning.
- 3—Completely balanced genuine Neutrodyne.
- 4—Volume Control.
- 5—Single tuning knob.
- 6—Illuminated dial.
- 7—Single cable to outside connections.
- 8—Designed for easy installation in consoles.
- 9—Beautiful frosted brown crystalline finish.

AC model using new R. C. A. AC tubes and working directly from electric light socket through Crosley Power Converter \$65. Power Converter \$60.

The value of this Bandbox receiver and the excellence of its performance can best be judged by seeing it and hearing it at the nearest Crosley dealers. If you cannot locate one of the 16,000 dealers, write Dept. 49 for his name and address and Crosley literature.

Approved Consoles



Selected by Powel Crosley, Jr., as ideal, acoustically and mechanically for the installation of the Crosley “Bandbox.” Genuine Musicone built in. Crosley dealers secure them from their jobbers through

H. T. ROBERTS CO.
1340 S. Michigan Ave.,
Chicago, Ill.

Sales Agents for Approved Console Factories
Showers Brothers Company
The Wolf Mfg. Industries

IMPROVED MUSICONES

Musicones improve the reception of any radio set. They are perfect affinities in beauty and reproductive effectiveness for Crosley Radios. A tilt-table model with brown mahogany finish stands 36 inches high, \$27.50—16-inch Super-Musicone as pictured above with “Bandbox,” \$12.75—12-inch Ultra-Musicone, \$9.75.



CROSLEY RADIO

THE CROSLEY RADIO CORPORATION
Powel Crosley, Jr., Pres. Cincinnati, Ohio
Prices slightly higher west of the Rocky Mts.



Crosley is licensed only for
Radio Amateur, Experimental and
Broadcast Reception

Whatever type of radio power equipment you want—

WITH BATTERIES OR WITHOUT

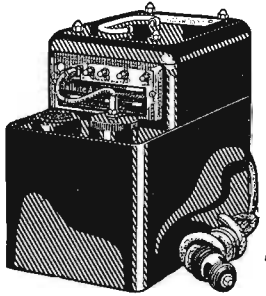

Licensed under Hammond-Andrews patent applications

Balkite "A"

Contains no battery. The same as Balkite "AB," but for the "A" circuit only. Enables owners of Balkite "B" to make a complete light socket installation at very low cost. Price \$32.50.

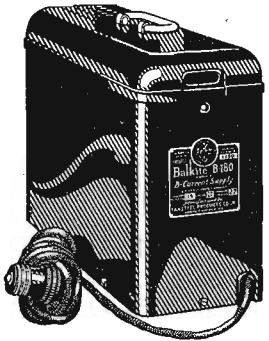

Balkite "B"

One of the longest lived devices in radio. The accepted tried and proved light socket "B" power supply. The first Balkite "B," after 5 years, is still rendering satisfactory service. Over 300,000 in use. Three models: "B"-W, 67-90 volts, \$22.50; "B"-135, * 135 volts, \$32.50; "B"-180, 180 volts, \$39.50. Balkite now costs no more than the ordinary "B" eliminator.



Balkite Chargers

Standard for "A" batteries. Noiseless. Can be used during reception. Prices drastically reduced. Model "J," * rates 2.5 and .5 amperes, for both rapid and trickle charging, \$17.50. Model "N," * Trickle Charger, rate .5 and .8 amperes, \$9.50. Model "K," Trickle Charger, \$7.50.

*Special models for 25-40 cycles at slightly higher prices.

Prices are higher West of the Rockies and in Canada.

for whatever type of radio set you own— whatever you want to pay for it—

Balkite has it

First noiseless battery charging. Then successful light socket "B" power. Then trickle charging. And today, most important of all, Balkite "AB," a complete unit containing no battery in any form, supplying both "A" and "B" power directly from the light socket, and operating only while the set is in use. The great improvements in radio power have been made by Balkite.

This pioneering has been important. Yet alone it would never have made Balkite one of the best known names in radio. Balkite is today the established leader because of Balkite performance in the hands of its owners.

Because with 2,000,000 units in the field Balkite has a record of long life and freedom from

trouble seldom equalled in any industry.

Because the first Balkite "B," purchased 5 years ago, is still in use and will be for years to come.

Because to your radio dealer Balkite is a synonym for quality.

Because the electrolytic rectification developed and used by Balkite is so reliable that today it is standard on the signal systems of most American as well as European and Oriental railroads. It is this principle, used in all Balkite Radio Power Units, that does away with the necessity of using tubes for rectifying current—that makes Balkite permanent equipment with nothing to wear out or replace.

Balkite has pioneered—but not at the expense of the public.

Today, whatever type of set you own, whatever type of power equipment you want, whatever you want to pay for it, Balkite has it. Production is so enormous that prices are astonishingly low.

Your dealer will recommend the Balkite equipment you need for your set.

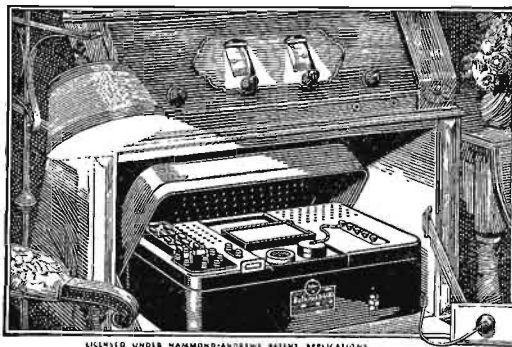

Balkite "AB" Contains no battery.

A complete unit, replacing both "A" and "B" batteries and supplying radio current directly from the light socket. Contains no battery in any form. Operates only while the set is in use. Two models: "AB" 6-135, * 135 volts "B" current, \$59.50; "AB" 6-180, 180 volts, \$67.50.

FANSTEEL PRODUCTS COMPANY, INC., NORTH CHICAGO, ILLINOIS

Licenseses for Germany:

Siemens & Halske, A. G. Wernerwerk M
Siemensstadt, Berlin

Sole Licenseses in the United Kingdom:

Messrs. Radio Accessories Ltd., 9-13 Hythe Rd.
Willesden, London, N. W. 10

FANSTEEL
Balkite
Radio Power Units

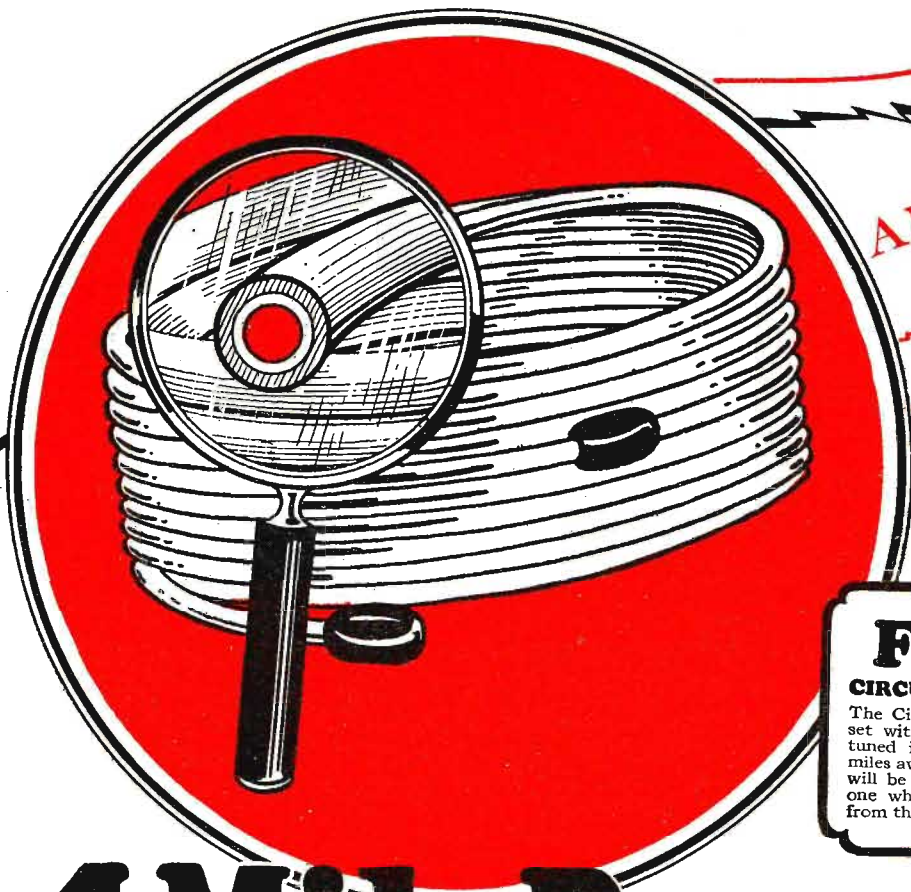
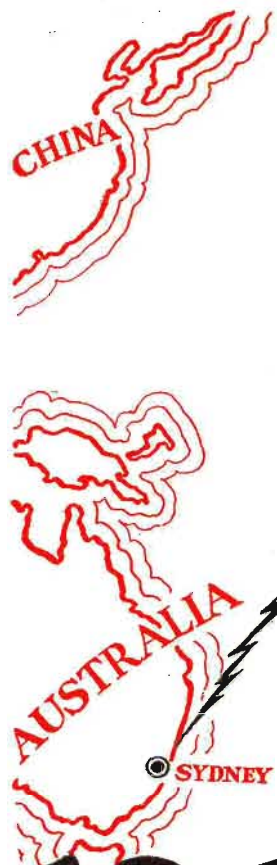

FREE
CIRCUIT DIAGRAM
 The Circuit diagram of the set with which Mr. White tuned in Australia—10,144 miles away on a Subantenna will be sent FREE to anyone who mails the coupon from this announcement.

10,144 Mile Reception with a SUBANTENNA



Mr. John White, of Brooklyn, N. Y., who tuned in Australia with a six tube set and a Subantenna.

10,144 miles—and the music came in loud and clear. Mr. John White residing at 217 Wyckoff Ave., Brooklyn, New York, established the world's distance record for reception within the B. C. L. band of 200 to 550 meters by tuning in 2FC and 3AR Australia with a simple six tube tuned radio frequency set—and a Subantenna. Think of it. 10,144 miles, and reception that was not only audible but loud, crystal clear reception music and song that Mr. White listened in on for some time before tuning it out and seeking other far away stations.

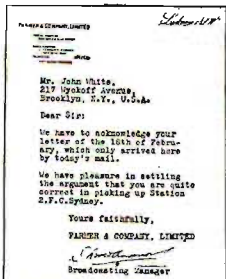

Confirming Letter from 2FC Sydney, Australia.

The results obtained by Mr. White prove the distance getting capabilities of Subantenna beyond all doubt. For Mr. White writes that during his tests, neither 2FC nor 3AR could be heard on a two hundred foot up-in-the-air aerial, but the instant he switched back to Subantenna, either station came in very clearly.

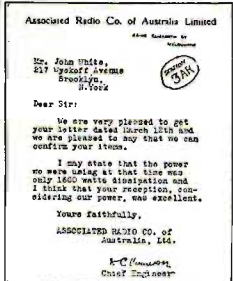

Confirming Letter from 3AR Melbourne, Australia.

Results—Almost Unbelievable!

"After 4 years of testing aerials I at last found the master in the Subantenna. The first night I used it was a very hot summer night. Static was very bad on my outdoor aerial. I connected my Subantenna and one could hardly believe the results. It was wonderful."—F. L. C., Mass.

Says "Static Is No More"

"I have received the Subantenna. My grandson installed it. STATIC IS NO MORE. Am well satisfied. I can tune in stations I never could coax out of the air even though I had a long aerial." A. E. F., Kan.

GROUND WAVES ARE PRACTICALLY STATIC FREE

That's Why Subantenna Gives Greater Distance and Clarity

The same radio waves that you have always taken out of the air also travel thru the ground. The only difference between the air, and ground components of the broadcast wave, is that the latter is practically static free, while the air component is always accompanied with static or noise of one kind or another. Scientists have long recognized this fact, and knew that if some device could be perfected for the reception of ground waves, clear, loud long distance reception would be a reality for the owner of the modest three or four tube set as well as for the possessor of the larger, more powerful set. Subantenna is the answer—tried, tested and proved by thousands of owners of all kinds of sets, and recommended to you by such leading radio laboratories as Radio News, Popular Radio, Radio Digest, and others.

TRY IT ON YOUR SET FREE

Install Subantenna. Leave your old aerial up. Select a bad night when DX is almost impossible with the ordinary aerial. Make a comparison station for station, connecting first your aerial, then Subantenna. If, from stations that are just a mess of jumbled noise with the old aerial, you don't get reception that rivals local in sweetness and clarity the instant you switch to Subantenna, this test won't cost you even a single penny. Obtain a Subantenna from your dealer or send coupon at once for scientific explanation of Subantenna and for particulars of GUARANTEE and FREE TRIAL OFFER. SEND COUPON NOW!

Other Users Get Greatly Increased Distance Too

Cuba—Also South America

"To show you that I received a program from Station PWX in Havana, Cuba, I enclose herewith a verification card from that station. On January 28th, I received a program on my set broadcasted from Buenos Aires, South America at 10:15 in the evening. Many other long-distance stations have been heard on my set after installing the Subantenna. I never could receive such distance on my outside antenna."—W. C. F., Chicago, Ill.

More Stations—No Static

"I get plenty of stations with my Subantenna, on the loud speaker, that I have never been able to reach with my outside aerial. It absolutely cuts down interference to the minimum, cuts static out too—not just partly out—but all out." H. S. M., North Carolina.

CLOVERLEAF MFG. CO.
 2713-G CANAL ST., CHICAGO, ILLINOIS

CLIP AND MAIL NOW

CLOVERLEAF MFG. CO.
 2713-G Canal St., Chicago, Illinois.

Tell me all about SUBANTENNA, your unqualified, unconditional guarantee and your FREE TRIAL OFFER.

Send me FREE Circuit Diagram of the set used by Mr. White in tuning in Australian stations. (Check here if you want circuit diagram).

Name.....

Address.....

a New
development !

Freshman EQUAPHASE

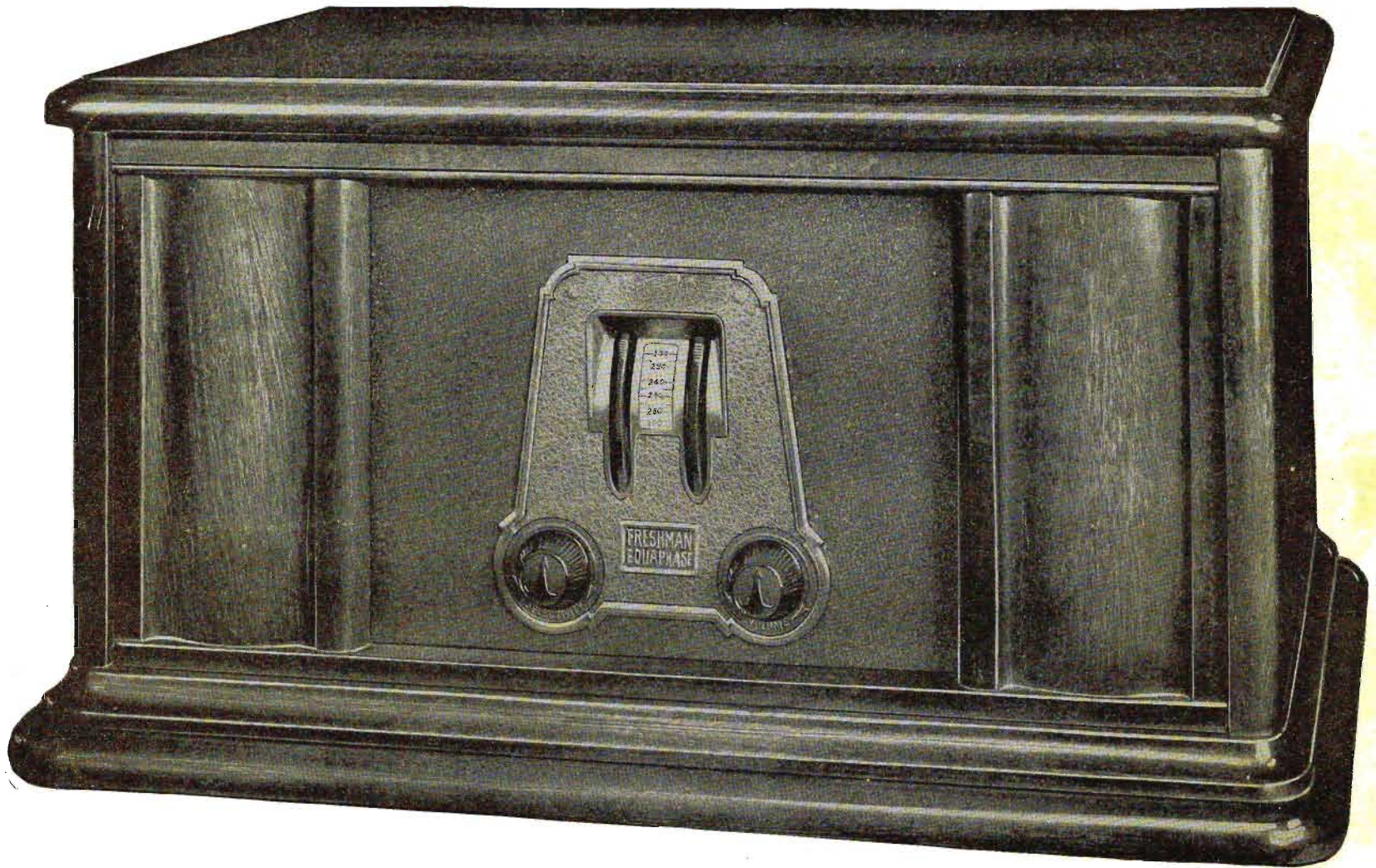

An entirely new principle of
stabilization and
these features :

- 1:** Four tuned circuits ✓ ✓ ✓ ✓ ✓ ✓
- 2:** Single drive — one control ✓ ✓ ✓ ✓
- 3:** Full floating tube shelf ✓ ✓ ✓ ✓ ✓ ✓
- 4:** Drum type illuminated dial — calibrated in wavelengths ✓ ✓ ✓ ✓ ✓ ✓ ✓ ✓
- 5:** Solid Mahogany cabinet — artistically high-lighted ✓ ✓ ✓ ✓ ✓ ✓ ✓ ✓

\$70

A Freshman development—licensed under patents;
RCA—General Electric Co.—Westinghouse
Electric & Mfg. Co. and American Tel. & Tel. Co.

Sold on Convenient Terms
by Authorized Freshman Dealers only

CHAS. FRESHMAN CO., INC. ✓ Freshman Building, New York ✓ Chicago ✓ Los Angeles