

Cascode A.F. Amplifier

“Long-tailed Cascode Pair” as Combined Pre-amplifier and Phase Splitter

By L. B. HEDGE, Ph.D.

THE “cascode” amplifier—a series connection of two triodes which operates much like a single triode, with characteristics practically unattainable in a single triode—has been extensively employed as a high-frequency amplifier during recent years, and more recently as a first-stage, low-level, audio-frequency amplifier (so-called “pre-amplifier”). Although the cascode was developed as a direct-current amplifier for voltage regulator control application¹, its recent uses have been largely based on the inherently low level of stage noise². The importance of minimizing the signal-to-noise ratio in a variety of high-frequency applications, including radar, television and many others, has served to keep attention focused on this low-noise feature as the distinguishing characteristic of the cascode, and its use in the audio-frequency field has also been based largely on this feature.

The amplifier here described (on which patents are pending) is the result of a return to an earlier view of the cascode stage; it is used here because of the characteristics for which it was originally developed—its triode-like performance and its high equivalent amplification factor. Although low noise is no disadvantage in any amplifier, it is of

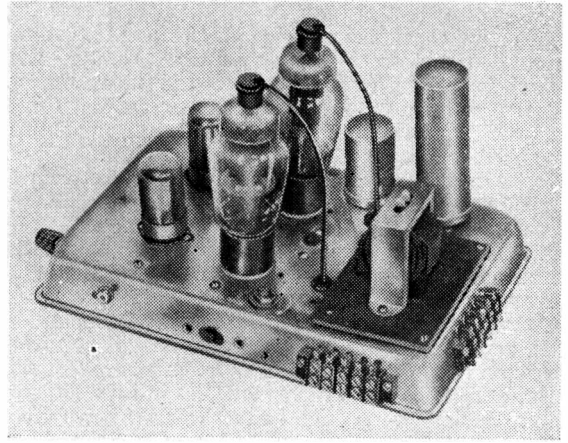

Amplifier with “replacement” output transformer.

importance only in a stage (the first, barring exceptional circuitry) where the input signal is of sufficiently low intensity to make the signal-to-stage-generated-noise ratio critically small. In the next-to-final stage of an audio-frequency power amplifier, only exceptionally bad design could make the noise generated in the stage a factor of significance in the performance of the system.

High quality in audio-frequency power amplifier performance—uniformity of response and low distortion over the spectrum of audible frequencies—depends in large measure on a few closely inter-related design elements; the output transformer, the feedback circuitry, and the frequency, phase-shift, and attenuation characteristics of the inter-stage couplings which establish the limits within which feedback may be used as an overall corrective³. In general the output transformer is the effective limiting element in amplifier performance, and recent impressive improvements have been based on special transformer designs⁴.

In exploring the problem of evolving an amplifier

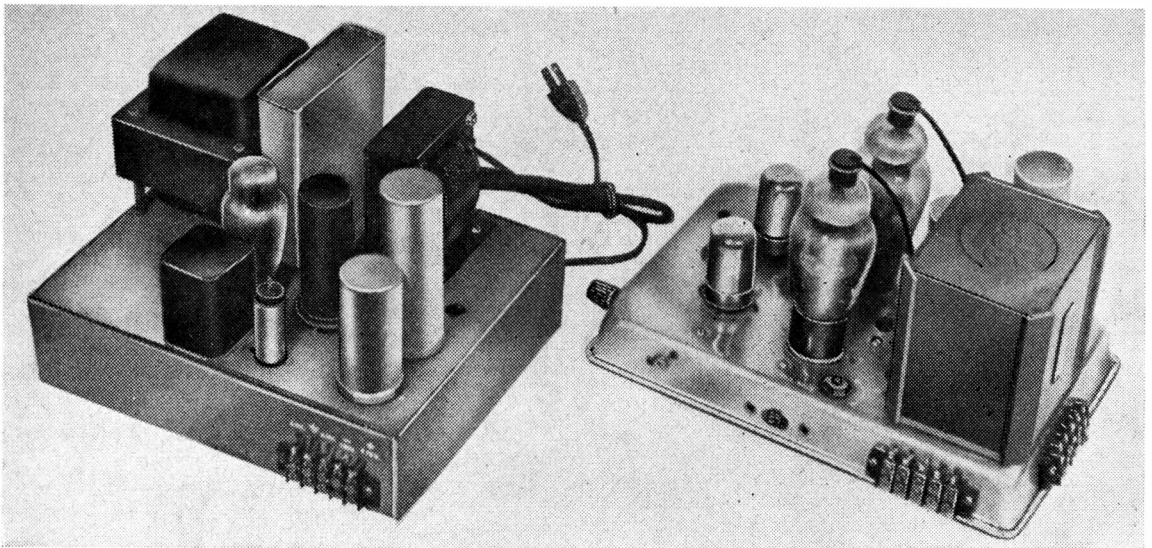

Complete amplifier and power supply. (UTC LS-55 output transformer.)

design which would make most effective use of an output transformer of non-critical design—one which would make the best use of any output transformer built into it—it soon became clear that some major changes in “conventional” circuitry would be required. A feedback loop to support a high level of corrective feedback which would include the output transformer and go back at least to the phase-inverter stage seemed a minimum reasonable requirement, and with conventional circuitry this leads to something very much like the basic “Williamson” layout. With the low gain of most popular phase-inverter stages, and the high drive requirements of the output stage, at least one driver stage is required between the phase inverter and the output stage, and an additional stage which may be either before or after the inverter. One direct coupling between stages (as in the Williamson scheme) is quite practicable, but more than one adds serious complications to the power supply and isolation filter problems. The result is a feedback loop which contains two R-C coupling networks and the output transformer, with a possible maximum phase shift of 270°. Stability

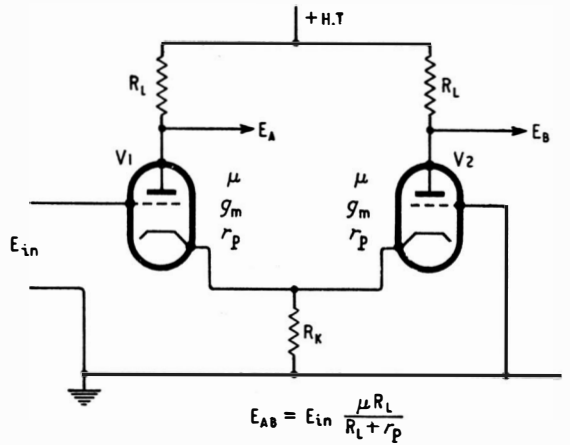
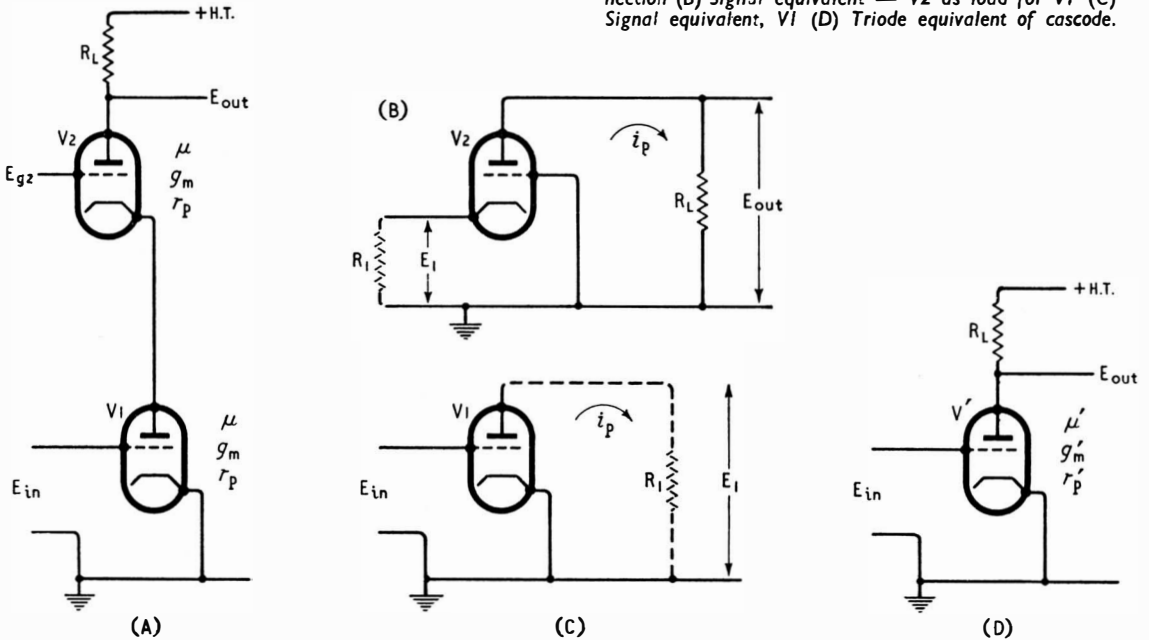

Fig. 1. Cathode-coupled phase-inverter (long-tailed pair).

Below:— Fig. 2. The cascode amplifier. (A) Cascode connection (B) Signal equivalent — V2 as load for V1 (C) Signal equivalent, V1 (D) Triode equivalent of cascode.



of the amplifier requires that the loop gain be reduced to less than 1 before the phase shift reaches 180°, and, in view of the phase-shift and attenuation characteristics of the couplings and the transformer, the frequency range over which feedback can be kept high must be considerably smaller than the usable range of the transformer itself³. The search for a reasonable way out of this vicious circle of conflicting constraints led to the analysis of the cascode and the cathode-coupled phase-inverter, and finally to the combination of the two—the “long-tailed cascode pair” (l.t.c.p.). www.keith-snook.info

The cathode-coupled phase-inverter is well known and has been extensively used (Fig. 1). The un-bypassed common-cathode resistor provides degenerative feedback to the input tube as well as driving potential for the grounded-grid inverter. The anode-to-anode output of this stage is independent of the value of the

$$(B) \quad E_i \mu = i_p (r_p + R_L) + E_i \quad (1)$$

$$i_p = \frac{E_i (\mu + 1)}{r_p + R_L} \quad (2)$$

$$R_i = E_i / i_p = \frac{r_p + R_L}{\mu + 1} \quad (3)$$

$$(A) \quad -E_{in} \mu = i_p (r_p + R_i) \quad (4)$$

$$i_p = \frac{-E_{in} \mu}{r_p + R_i} \quad (5)$$

$$i_p = \frac{-E_{in} \mu}{\frac{r_p + R_L}{\mu + 1} + r_p} = \frac{-\mu (\mu + 1) E_{in}}{R_L + (\mu + 2) r_p} \quad (6) \text{ (3 \& 5)}$$

$$\frac{E_{out}}{E_{in}} = \frac{i_p R_L}{E_{in}} = \frac{-\mu (\mu + 1) R_L}{R_L + (\mu + 2) r_p} = \frac{-\mu' R_L}{R_L + r_p'} \quad (7)$$

cathode resistor if the two valves are matched and the anode load resistors are equal, and the ratio of the two anode-to-earth output voltages is⁶:—

$$\frac{E_A}{E_B} = 1 + \frac{R_L + r_p}{(\mu + 1)R_k} \quad (1)$$

Precise balance can be provided by selection of R_k and R_L for given tube characteristics, but if high gain and reasonable power supply voltage requirements are to be realized, μ must be exceptionally large.

The cascode amplifier consists of a conventional triode with a cathode-driven triode as its anode load (Fig. 2). Analytically the cascode takes the form of a fictitious triode with characteristics μ' , r'_p , and g'_m the values of which, expressed in terms of the characteristics of the component triodes (assumed identical) μ , r_p , and g_m , are:

$$\left. \begin{aligned} \mu' &= \mu(\mu + 1) \\ r'_p &= (\mu + 2)r_p \\ g'_m &= \frac{\mu'}{r'_p} = \frac{\mu(\mu + 1)}{(\mu + 2)r_p} = \frac{\mu + 1}{\mu + 2} g_m \end{aligned} \right\} (2)$$

Typical twin-triodes in cascode connection should thus provide characteristics as follows:—

Type	μ	r_p	g_m	μ'	r'_p	g'_m
6SN7						
7N7	20	7 k Ω	2.9	420	0.15M Ω	2.8
6SL7						
7F7	70	44 k Ω	1.6	5000	3.2M Ω	1.6

Anode characteristic curves for these two types were constructed for design reference (Fig. 3). The curves represent measurements on one valve of each type, and may not be good averages in the accepted sense. They do provide, however, an approximate basis for selection of operating points and load-line constructions. Dynamic checks with loads as indicated on the curves and anode supply voltage (E_{bb}) of 475 V

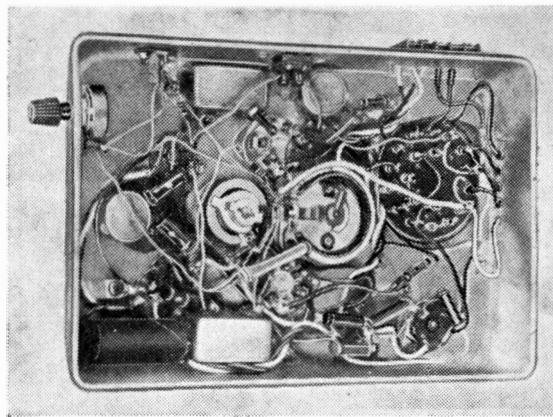

Under-chassis view of the complete i.t.c.p. amplifier.

(the approximate value normally available in an audio-frequency power amplifier, and the maximum available from my regulated adjustable supply unit) check reasonably well with the curves, and even better with the computed values. Within the regions of good linearity to the two cascades the 6SN7/7N7 should provide a gain of approximately 128 with a load resistance of 66k Ω and an anode supply of 475 volts, while the 6SL7/7F7 should provide a gain of about 360 with a load of 250k Ω and the same anode supply voltage. On the basis of this analysis the experimental amplifier was laid out using 7F7's in the i.t.c.p. stage.

The final circuit of the amplifier is shown in Fig. 4. Type 1625 output valves (12-volt heater versions of the 807—similar in general characteristics to the KT66) were used because they were at hand—as were the

Fig. 3. Cascode amplifier anode characteristics and dynamic check test.

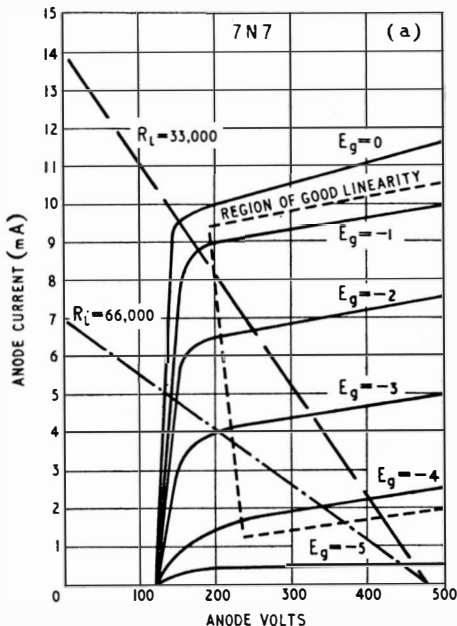

DYNAMIC CHECK — $R_L = 33,000$, $E_{bb} = 475V$, $E_{g2} = 120V$, $E_g = -2V$,
 $E_{IN} = 0.1V$ r.m.s., $E_{OUT} = 7.5V$ r.m.s.

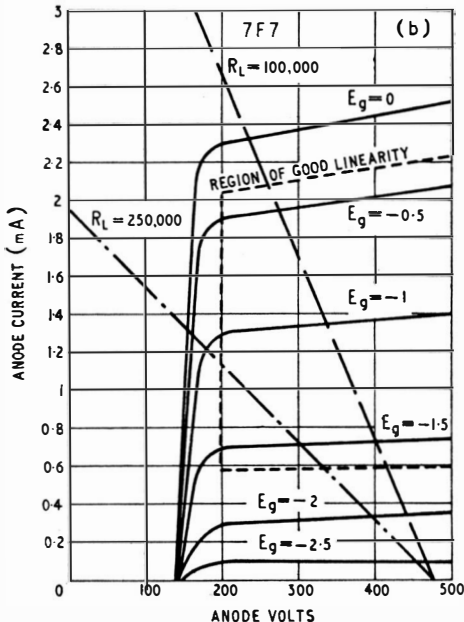

DYNAMIC CHECK — $R_L = 100,000$, $E_{bb} = 475V$, $E_{g2} = 150V$, $E_g = -1V$,
 $E_{IN} = 0.1V$ r.m.s., $E_{OUT} = 14V$ r.m.s.

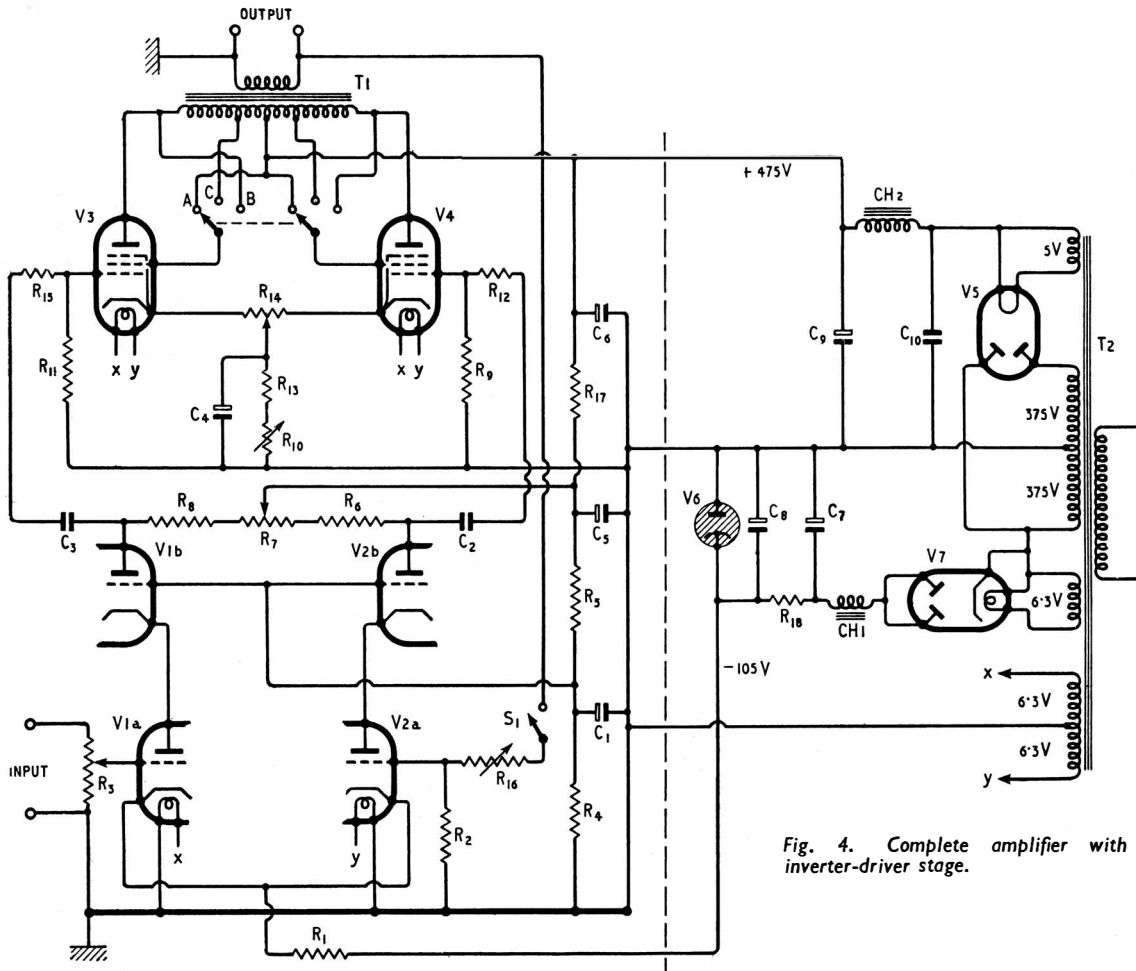

Fig. 4. Complete amplifier with inverter-driver stage.

LIST OF PARTS

C ₁ , C ₇	20μf, 450V electrolytic	R ₉ , R ₁₁	400kΩ, ½ watt
C ₂ , C ₃	0.1μf, 600V	R ₁₀	200Ω rheostat, 10 watt (Output bias adjustment)
C ₄	120μf, 150V electrolytic	R ₁₂ , R ₁₅	1kΩ, ½ watt
C ₅ , C ₆	40μf, 450V "	R ₁₃	100Ω, 5 watt
C ₈	40μf, 350V "	R ₁₄	100Ω pot., 5 watt (Output cathode balance adjustment)
C ₉	40μF, 450V "	R ₁₆	1MΩ pot. (Feedback adjustment)
C ₁₀	10μf, 600V	R ₁₇	4.7kΩ, ½ watt
Ch ₁	5H, 300 ohm, 40mA choke	R ₁₈	15kΩ, 10 watt
Ch ₂	10H, 90 ohm, 200mA choke	S ₁	S.P.S.T. switch (Feedback disconnect)
R ₁	50kΩ, 1 watt	T ₁	Output transformer—(See text)
R ₂	68kΩ, ½ watt	T ₂	Power transformer 375-0-375V, 200mA, heater as required
R ₃	500kΩ (volume control)	V ₁ , V ₂	7F7; V ₃ , V ₄ , 1625; V ₅ , 574; V ₆ , OB2; V ₇ , 6X4.
R ₄	47kΩ, ½ watt		
R ₅	100kΩ, 1 watt		
R ₆ , R ₈	220kΩ, 1 watt		
R ₇	50kΩ pot., ½ watt		

7F7's. The essential symmetry of the l.t.c.p. stage suggested immediately the closure of the feedback loop through the grid circuit of the grounded-grid inverter, since satisfactory introduction of the feedback voltage into the input grid circuit is somewhat complicated by the presence of the volume control. Pentode, triode, and so-called "ultra-linear" operation of the output stage is provided by the alternative connections (A, B, and C, Fig. 4) for the screen grids of the 1625's.

Performance of the complete amplifier was checked

using a United Transformer Company's LS-55 transformer as a reference—a typical "good" transformer (reference 7 covers its use in the "ultra-linear" connection)—and a "universal replacement" type, unidentified by manufacturer's name or model designation, culled from the shop "junk box," as a kind of "worst possible" unit for evaluation of the system. Fig. 5 indicates the effectiveness of the system in providing adequate drive and stable operation at high corrective feedback levels.

The complete amplifier—a "bread-pan layout"⁸—

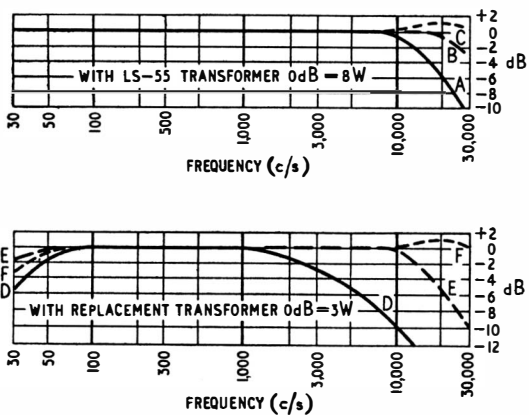

Fig. 5. Performance characteristics of complete amplifier.

- Curve A 0dB feedback 0.16V r.m.s. input—U-L connection
- Curve B 10dB feedback 0.52V r.m.s. input—pentode connection
- Curve C 10dB feedback 0.38V r.m.s. input—U-L connection
- Curve D 0dB feedback 0.25V r.m.s. input—pentode connection
- Curve E 10dB feedback 0.12V r.m.s. input—triode connection
- Curve F 10dB feedback 0.80V r.m.s. input—triode connection

Maximum output watts with harmonic distortion less than 1%:

Transformer Connection	Replacement Triode		Transf. Pentode		LS-55 Transformer U-L		Pentode	
	0dB	10dB	0dB	10dB	0dB	10dB	0dB	10dB
30 c/s	0.1	0.5	0.1	0.5	12	18	10	15
100 c/s	1	6	1	8	12	18	12	15
1,000 c/s	3	6	3	8	12	18	12	15
10 kc/s	3	6	3	8	12	18	12	15

Note: Increase in feedback from 10 to 20dB with increase in input voltage of approx. x3 changes output characteristics less than 1dB with LS-55 transformer and less than 2dB with the replacement transformer.

is shown in the photographs. As may be surmised, neither construction, layout, nor wiring is critical in any sense. The -105volt supply required for the cathodes of the l.t.c.p. stage is an exceptional requirement, but it is easily met by a simple modification of a conventional power supply, as shown in the wiring diagram of Fig. 4. Since each d.c. connection to the amplifier is to a symmetrical and balanced load, isolation, hum and ripple filter can be quite simple.

The output stage cathode bias scheme shown is simple and effective for providing final stage balance, but it is not in any way a special feature—the Williamson-type network should be equally effective. The cathode bypass condenser in this stage is not necessary either, but the author prefers to use it since it tends to reduce distortion if and when the output tubes, by ageing or for other reasons, depart from perfect balance. No provision has been made for static balance of anode currents in this stage, since the author's experience and tests indicate that dynamic balance will produce lower distortion, and that dynamic and static balance frequently occur at different bias adjustment settings.

The "long-tailed cascode pair," by eliminating one inter-stage coupling without reducing gain or seriously complicating the power supply requirements of the conventional power amplifier system, makes the use of output transformers of non-critical

design consistent with high quality and exceptional stability. With a real "dog" for an output transformer, this "tail" will wag it so that it will perform like a thoroughbred!

REFERENCES

- ¹ Hunt, F. V., and Hickman, R. W., "On Electronic Voltage Stabilizers," *Review of Scientific Instruments*, January 1939, p.6. www.keith-snook.info
- ² Wallman, H., Macnee, A. B., and Gadsden, C. P., "A Low-Noise Amplifier," *Proc. I.R.E.*, June 1948, p.300.
- ³ Terman, F. E., "Radio Engineers Handbook," McGraw Hill, 1943, p.395.
- Nyquist, H., "Regeneration Theory," *Bell System Technical Journal*, January 1932, p.126.
- ⁴ Williamson, D. T. N., "Design of a High Quality Amplifier" *Wireless World*, April 1947, p.118, and May 1947, p.161.
- Williamson, D. T. N., "High Quality Amplifier—New Version" *Wireless World*, Aug. 1949, p.282. Oct. 1949, p.365, and Nov. 1949, p.423.
- ⁵ Terman, F. E., *loc. cit.*, p.224.
- ⁶ Langford-Smith, F., "Radio Designer's Handbook," p.347. Iliffe and Sons Ltd.
- Richter, W., "Cathode Follower Circuits," *Electronics*, November 1943, p.112. www.keith-snook.info
- ⁷ Brewer, F. T. C., "A Linear Power Amplifier," *Radio and Television News*, April 1953, p.64.
- ⁸ Hedge, L. B., "The Bread-Pan Layout," *Audio Engineering*, August 1953, p.24.